



## Exploratory Category Structure of the Formation of Intellectual Capital

Eloísa Segura-Ovalle<sup>1</sup>, María Luisa Quintero-Soto<sup>2</sup>, Héctor Daniel Molina-Ruíz<sup>3</sup>, Francisco Rubén Sandoval-Vázquez<sup>4</sup>, María Guadalupe Albarado-Ibarra<sup>5</sup>, Cruz García-Lirios<sup>6</sup>

<sup>1</sup>Unidad Académica Profesional Huehuetoca / Universidad Autónoma del Estado de México: [esegurao@uaemex.mx](mailto:esegurao@uaemex.mx)

<sup>2</sup>Unidad Académica Profesional Nezahualcóyotl / Universidad Autónoma del Estado de México: [mlquinteros@uaemex.mx](mailto:mlquinteros@uaemex.mx)

<sup>3</sup>Instituto de Ciencias Económico Administrativas / Universidad Autónoma del Estado de Hidalgo, Tepeji (México): [hmolina@uaeh.edu.mx](mailto:hmolina@uaeh.edu.mx)

<sup>4</sup>Facultad de Ciencias Políticas / Universidad Autónoma del Estado de Morelos, Cuernavaca (México): [fsandoval@uaem.mx](mailto:fsandoval@uaem.mx)

<sup>5</sup>Facultad de Ciencias Económico Administrativas / Universidad de Sonora, Navojoa (México): [lalvarado@navojoa.uson.mx](mailto:lalvarado@navojoa.uson.mx)

<sup>6</sup>Facultad de Ciencias de la Gobernanza / Centro de Estudios Políticos y Sociales, Cuernavaca (México): [garcialirios@ceps.mx](mailto:garcialirios@ceps.mx)

### Abstract

The objective of the present work was to specify a model for the study of governance training. The theory intellectual capital essentially means that there is an indirect relationship between vocational training and job placement. Leadership styles are mediators in this process because they transfer values and norms that guide needs and expectations, as well as skills and knowledge to carry out the tasks and achieve the achievements. A non-experimental, documentary, cross-sectional and exploratory study was carried out with a selection of sources indexed to Latin American leading repositories, considering the publication period and ISSN and DOI registration; Dialnet, Latindex, Publindex, Redalyc and Scielo repositories. Since the specified model can be contrasted, the inclusion of factors such as empowerment and entrepreneurships are recommended to establish the scope and limits of the model.

**Keywords:** *Human capital, Vocational training, Job placement, Model, Specification.*

### Introduction

The purpose of this research is to specify a model of dependency relations between the variables determining and indicative of governance training.

The university degree is more profitable for women than for men when compared to other educational levels. University graduates earn 41% more than high school graduates, while in men this difference is 32%. The university students also have a level of employment (94.1% among the graduates) much major than other

educational levels (86.7% among the graduates of compulsory secondary). The relative salary of university students compared to workers with lower secondary education has dropped by 40%. The university advantage in terms of unemployment has also declined. The unemployment rate of secondary school graduates has decreased from 73% higher than that of university students to 17% between 1995 and 2005. The same rate has not changed in the case of comparing it with

workers with pre-secondary education (Around 40% higher than university students). The difference in the employment rate among graduates of compulsory education and university graduates has dropped from 19 to 13 points between 1997 and 2004 [1].

52.2% of the university graduates interviewed continue to live in their parents' homes despite their high occupancy and average age (28 years). The clear majority of graduates (74.8%) attended courses they chose as the first option. University graduates take an average of 6.2 months to find their first job after college [2].

Early contacts with the world of work often involve a temporary contractual relationship (74.9% in the first job) after three years' graduates reach a much higher level of job stability. In the last employment, the indefinite contracts represent 45.1% of the total contracts of the graduates of the sample [3].

In the last job, 27.6% had a higher education level and 10.4% dissociated the tasks from their job with the university degree. 70.7% of graduates are quite satisfied or very satisfied with their current job, although only 47.7% of respondents are quite or very satisfied with their salary [4].

72% would return to do the same race in the same university. However, 17.7% of the graduates of the sample indicate that if they had to take the decision again for university studies, there would not do it with a high degree of probability [5].

The official unemployment rate in the period in which they were surveyed (11.2%) is somewhat lower than the median cited by the respondents (15%). The unemployment rate estimated by the students is close to that when they began their studies, so the explanation could be certain inertia in their expectations [6].

The perception of the labour market situation is very close to reality. The unemployment rate for young university graduates (under 30) is 15% (real rate in 2003: 15.5%) while 90% of the employment rate for young people are graduates and / or Vocational training [7].

Within the framework of Human Development in which health, education and employment are its most prevalent dimensions. The concept of human capital alludes to a balance between demands and

resources, opportunities and capacities, as well as skills and knowledge each one oriented towards insertion in a global and local labour market [8].

Thus, human capital involves a set of strategies, intentions and actions dedicated to the application of knowledge and the development of skills so that, based on objectives and tasks of cooperation, goals are obtained, which are disseminated among a group that Can reproduce the process with the same quality [9].

However, the theory of human capital warns that there are barriers and facilitators that inhibit or potentiate the realization of purposes. This is the case of the relationship between vocational training and job placement. Because syllabus seems to be disconnected from the demands of the global or local market, vocational training increasingly conforms to the requirements of the working environment [10].

Although vocational training is close to the skills and knowledge required by micro, small and medium-sized organizations that employ 90% of the workforce, labour insertion involves a selection process involving different professionals competing for a reduced number of vacancies [11].

In this way, the human capital theory in its formative aspect indicates that the contents and the practices conform to the real cases of the organizations that employ the graduates [12].

Nevertheless, the global labour market increasingly requires greater entrepreneurship, innovation and competitiveness without underestimating the empathy, commitment and satisfaction that employees must have to efficiently perform their work. Therefore, the formation of human capital also implies a degree of freedom of decision and action oriented to the transformation of organizations [13].

In this sense, human capital theory warns that vocational training depends on the formation of transformational rather than traditional leadership. This is because entrepreneurship, innovation and competitiveness depend on high doses of trust, commitment and job satisfaction. In that sense, human capital is the essential growth factor in an organization [14].

As an organization's currency, human capital requires continuous training and even anticipation of uncertainty and risk

scenarios. The coping of threats suggests the formation of leaders who transform the organization and do not chain it into a traditional, vertical and univocal style of leadership [15].

In this way, the formation of human capital will correspond to labour insertion whenever the market demands more and more innovative products and services that satisfy the consumers [16].

In the case of Higher Education Institutions (HEIs), the formation of human capital and labour insertion depends on a high degree of institutional isomorphism that human capital theory considers fundamental to carry out the task of anticipating unemployment scenarios [17].

Roughly, institutionalism consists of a set of values and norms that affect the culture and the work climate of the relationships and the work climate of the tasks. This is because organizations are confined to business development policies, or to alliances with the state that determine them in terms of their business relationships [18].

In this institutional framework, human capital theory suggests that leaders share goal-oriented styles of management regardless of the skills and knowledge that guide innovation, but they regulate the proposals that emerge from organizations associated with state institutions [19].

However, when organizations need to transcend and enter the global market they establish strategic alliances with other organizations that condition their association according to the degree of entrepreneurship, innovation and competitiveness. In this context, human capital theory explains the process by which individuals establish networks of knowledge and, based on their capacity for information processing, decision making and execution skills, achieve a level of competence according to local and global demands [20].

If entrepreneurship consists of balancing financial opportunities, establishing business opportunities and producing goods with a high demand, then human capital is an essential part of the entrepreneurship process, since, based on continuous training in processing Information and dissemination of proposals has competitive advantages [21].

In the case of innovation, understood as the generation of initiatives according to a

demand and the feasibility of being reproduced to reach a quota of productivity, human capital formation also shows competitive advantages over organizations dedicated to reproducing knowledge. That producing knowledge not only applicable but reproducible generates prestige and this is crystallized in patents [22].

In this way, the formation of human capital is increasingly close to guarantee labour insertion due to its high degree of transformation and expectations of knowledge reproduction [23].

Human capital studies indicate that the intensive uses of information technologies, as well as the orientation of traditional leaders that establish deliberate, planned and systematic processes are determinants of professional training and even labour insertion. In this sense, as software learning intensifies, and traditional leaders are learned, labour insertion is closer to being achieved [24].

However, in organizations with a more democratic, open, participative, horizontal and intercultural work culture, information and communication technologies, including digital networks, are not determinants of professional training and insertion in local marking. This means that the diversity of demands and resources seems to corroborate the hypothesis that entrepreneurship and innovation do not necessarily correspond to productivity and competitiveness, but to job satisfaction [25].

In fact, the type of work culture affects the climate of relations, the climate of goals, the climate of task and the climate of innovations. It is the electronic technologies and devices that enhance the learning of skills that the global market requires but inhibits opportunities in the local market [26].

The differences between the global market and the local market consist of the values and norms that in the first case are more practical and oriented to the consumption; it will show that in the second case the satisfaction is a common good that is persecuted in a locality [27].

The differences between a locality and a city determine the type and size of the organization, but also condition the reach and expectations of human capital. From values and norms that can be local or institutional, transformational leaderships

are not always the factor that organizations require to be inserted in one or another global or local scope [28].

In this way, the formation of human capital is determined by a series of variables that precede or proceed, although depending on the type and size of the organization will be the factor of change, entrepreneurship, innovation and competitiveness, but if this is possible in A labour environment where trust, commitment and satisfaction do not prevail, then human capital will lose its influence [29].

## Method

A non-experimental, documentary, cross-sectional and exploratory study was

carried out with a non-probabilistic selection of sources indexed to leading repositories in Latin America. The information was processed in content analysis matrices with the purpose of specifying the model of reflective dependency relations between the constructs of professional formation and labour insertion.

The documentation to be analysed was selected considering the publication period from 2000 to 2018, the conceptualization of the keywords: “capital”, “formation”, “knowledge”, as well as its ISSN (International Standard Serial Number) and DOI (Digital Object Identifier); Dialnet, Latindex, Publindex, Redalyc and Scielo repositories (see Table 1).

	<i>Capital</i>	<i>Formation</i>	<i>Knowledge</i>
<i>Dialnet</i>	46	32	20
<i>Latindex</i>	32	27	17
<i>Publindex</i>	22	14	10
<i>Redalyc</i>	13	8	7
<i>Scielo</i>	8	3	3

**Table 1. Descriptive data information**

Source: Elaborated with data study

The analysis of the content was based on the symptom technique, which consists in processing the concepts and their relationship in a network based on the

breakdown that the authors perform and the discussion they establish regarding the keywords (see Table 2).

	<b>Concept</b>	<b>Indicator</b>	<b>Codification</b>	<b>Interpretation</b>
<b>Capital</b>	Refers to the portability of knowledge, experiences, knowledge, visions and perspectives of optimization and innovation of data	Data alluding to academic, professional and work performance	-1 for information unfavorable to the formation of human capital, 0 for unlinked information, +1 for favorable information	High scores refer to knowledge management in consolidation
<b>Formation</b>	It refers to the adjustment of institutional capacities and resources in relation to the demands, challenges and challenges of the environment	Data related to entry and exit in the process of formation and establishment of strategic alliances between higher education institutions and for-profit organizations	-1 for information unfavorable to the formation of human capital, 0 for unlinked information, +1 for favorable information	High scores refer to knowledge management in consolidation
<b>Knowledge</b>	Suggests the concatenation of skills and experiences, needs and expectations depending on the availability of resources and the requirements of the environment	Data alluding to the generation of patents, production of literature, citations of articles and positioning of the scientific and technological literature of a higher education institution in partnership with an organization	-1 for information unfavorable to the formation of human capital, 0 for unlinked information, +1 for favorable information	High scores refer to knowledge management in consolidation

**Table 2. Construction data matrix**

Source: Self-made

The specification of the model was carried out assuming that the constructs of

human capital, vocational training and labour insertion maintain relations of

dependability testable. In this way the routes of conceptual relations were drawn.

Expert judges qualify a selection of synthetic data in order to establish the axes

and themes of the consulted literature agenda

## Results

S	M	SD	SW	K	C1 (Capital)	C2 (Formation)	C3 (Knowledge)
S1	Talent	,982	,192	,123	,123	[X <sup>2</sup> = 11,1 (13 gl) p = ,01]	
S2	Capability	,932	,130	,135	,130	[X <sup>2</sup> = 14,2 (14 gl) p = ,01]	
S3	Skills	,941	,124	,178	,132	[X <sup>2</sup> = 13,2 (13 gl) p = ,01]	
S4	Experience	,921	,148	,197	,145	[X <sup>2</sup> = 13,1 (14 gl) p = ,01]	
S5	Alliances	,943	,146	,145	,136	[X <sup>2</sup> = 11,1 (13 gl) p = ,01]	
S6	Collaboration	,987	,132	,126	,149	[X <sup>2</sup> = 12,4 (10 gl) p = ,01]	
S7	Practice	,950	,189	,165	,129	[X <sup>2</sup> = 14,1 (12 gl) p = ,01]	
S8	Optimization	,937	,125	,170	,107		[X <sup>2</sup> = 13,1 (14 gl) p = ,01]
S9	Innovation	,983	,108	,146	,178		[X <sup>2</sup> = 16,1 (12 gl) p = ,01]

**Table 3. Descriptive results**

S = Subcategory, M = Mean, SD = Standar Deviation, SW = Sweedness, K = Kurtosis, C = Category  
Source: Elaborated with data study

The relationship between human capital formation and labour insertion would be mediated by leadership, which in a sense is also a training process, but unlike employees, leaders are mediators of vocational training and job placement.

In the case of the formation of human capital, this involves factors that reflect it as

is the case of values, norms, demands, learnings, skills, knowledge and intentions.

About labour insertion, this would be indicated by levels of needs, expectations, opportunities, capacities, supports, tasks and achievements.

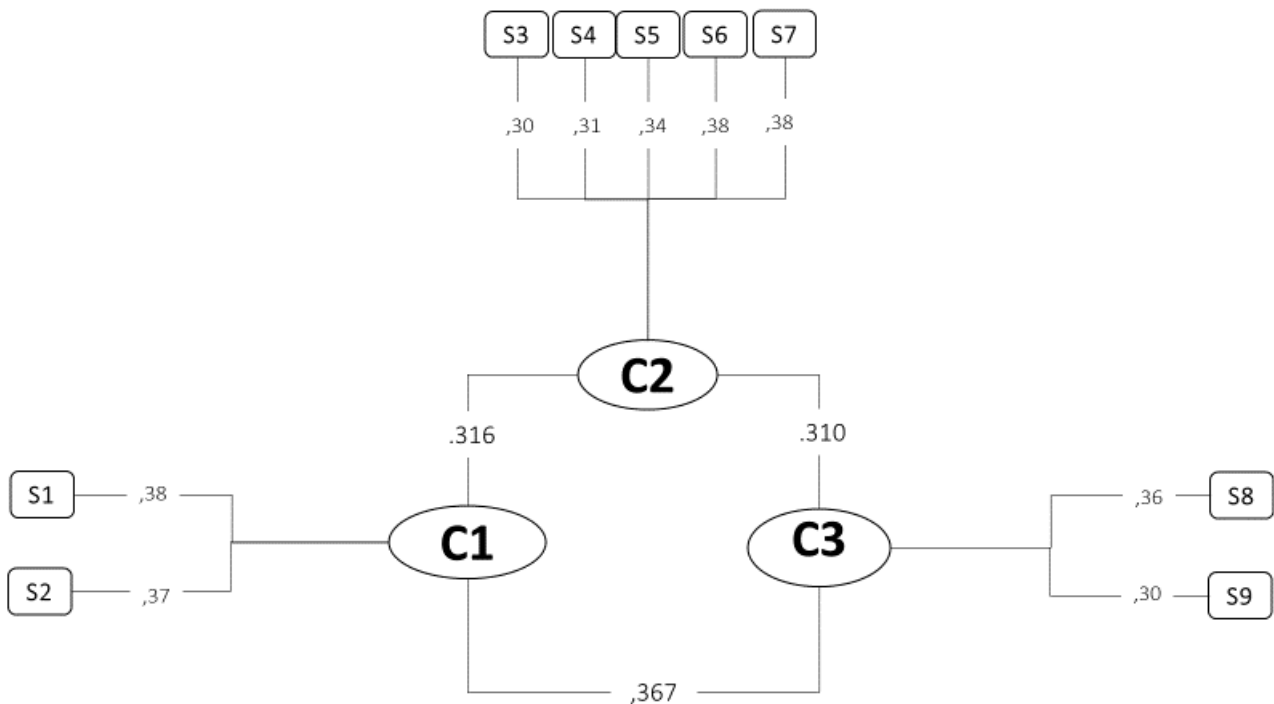

**Figure 1. Exploratory Category Structure**

C1 = Intellectual Capital, C2 = Laboral Formation, C3 = Knowledge Production: S1 = Talent, S2 = Capability, S3 = Skills, S4 = Experience, S5 = Alliance, S6 = Collaboration, S7 = Practice, S8 = Optimization, S9 = Innovation

Source: Elaborated with data study

The categorical exploratory structure indicates the prevalence of three factors related to intellectual capital, labor

training and knowledge production which would be linked to nine subcategories; Talent, ability, skill,

experience, partnership, collaboration, practice, optimization and innovation.

## Final Considerations

The contribution of this work to the state of knowledge and the revision of the literature consists of the specification of a model for the study of governance training intellectual capital.

In relation which human capital formation depends on the level of scientific and technological development, the present study warns that technologies, devices and information networks are a key factor in the explanation of organizations dedicated to the Establishment of strategic alliances but ignored in the cooperative societies as competitive advantage.

The formation of human capital seems to be determined by the context and culture of the organization. In that sense, the specification of a model will allow the contrast of the normative and normative determinants of the organizations with respect to the internal capacities and resources.

Vocational training is a result of business development policies that include constant evaluation processes. In this sense, the quality of the processes inside the organizations determines its structure and also the requirements of selection and training of personnel.

In contrast, the present paper argues that the formation of human capital depends on the level of talent crystallized in skills and knowledge rather than the climate of relationships and tasks that are established in organizations dedicated to the quality of their processes and products.

The formation of human capital, in relation to labour insertion, would be closer

to the mediation that the transformational leadership exerts on the employee and the commitment that he acquires and develops before the demands of his leader. It is a process in which the learnings have a greater impact than training and therefore condition labour satisfaction.

The work commitment is the result of a climate of empathic relationships between leaders and followers, but also entails the learning of norms and values of cooperation that, in the case of corporations, seem to be distant from their objectives, tasks and goals.

In the present work, the specification of a model for the study of governance training of intellectual capital is based on the establishment of values and norms as reflective indicators, but in relation to the expectations and capacities of the insertion in the labour market.

However, the course and personal trajectory differs from group goals, tasks and goals. Even with the formation of networks of knowledge, personal expectations and abilities seem to follow performance schemes acquired from leaders, but especially from peers. In this sense, the inclusion of factors that inhibit vocational training and job placement such as stress, burnout and mobbing is recommended.

Job satisfaction do not depend on skills or knowledge, but rather on skills that in the case of emotional intelligence are a preponderant factor in performance, innovation and job satisfaction. The present study does not include these emotional, affective and sentimental variables, but it is recognized that, coupled with the intensive use of technologies, devices and electronic networks, it potentiates the formation of human capital and gives competitive advantages for labour insertion.

## References

1. Aguilar, J. A., Pérez, M. I., Pérez, G., Morales, M. L. y García, C. (2018) Gobernanza de las redes de conocimiento: Contrastación de un modelo para el estudio de la formación consensuada. *Alternativas*. 40. (1):24-50.
2. Anguiano, F., Hernández, G. y García, C. (2018). Modelo especificado para el estudio de las expectativas en torno a la globalización. *Atlante*, 2 (1): 1-14
3. Carreón, J., Hernández, J. y García, C. (2018). Governance of intangible capitals. *International Journal of English Literature and Social Science*. 3 (4): 1-16
4. Delgado, M. A., García, C. y Mejía, S. (2018). Especificación de un modelo para el estudio de

- la migración consensuada. *Ehquidad*. 9 (1): 33-49
5. Elizarraráz, G., Molina, H. D., Quintero, M. L. Sánchez, R. y García, C. (2018). Discursos en torno a la lucidez organizacional en las alianzas estratégicas y las redes de conocimiento en mipyme caficadoras del centro de México. *Margen*. 88. 1-11
  6. Espinoza, F., Sánchez, A. y García, C. (2018). Modelo de gestión del conocimiento en caficadoras del centro de México. *Atlante*. 6 (1): 1-13
  7. García, C. (2018). Confiabilidad y validez de un instrumento que mide la gestión del conocimiento. *Tlatemoani*. 27 (1): 285-304
  8. García, C. (2018). Emprendimiento caficador en migrantes de la región huasteca del centro e México. *Equidad y Desarrollo*. 30 (1): 119-147 doi: <http://dx.doi.org/10.19052/ed.4324>
  9. García, C. (2018). Especificación de un modelo para el estudio de las expectativas en torno a la globalización. *Ajayu*. 16 (2), 73-98
  10. García, C. (2018). Interpretaciones de discursos de gestión del conocimiento para la comprensión de narrativas del emprendimiento innovador. *Inclusiones*. 5 (1): 96-111
  11. García, C. Espinoza, F. y Carreón, J. (2018). Model of intangible assets and capitals in organizations. *International Journal of Research in Humanities and Social Studies*. 5 (6): 1-12
  12. García, C., Martínez, E. y Rivera, P. E. (2018). Flexibilidad laboral en la educación superior. *Inclusiones*. 5 (1): 51-59
  13. García, C., Rivera, P. E., Martínez, E. (2018). Cultura institucionalista académica en Cuernavaca, Morelos (México). *Inclusiones*. 5 (1): 84-96
  14. García, C. (2018). Contrastación de un modelo de cultura organizacional en universidades públicas del centro de México. 4 (1): 1-17
  15. Hernández, J., Anguiano, F., Valdés, O., Limón, G. A. y García, C. (2018). Confiabilidad y validez de una escala que mide expectativas de la formación laboral. *Margen*. 89 (1): 1-13
  16. Hernández, J., Carreón, J. y García, C. (2018). Governance a quality control in a mexican organization in central México. *International Journal of Advances in Social Science*. 6 (1): 1-7
  17. Hernández, J., Carreón, J., Bustos, J. M. y García, C. (2018). Modelo de cibercultura organizacional en la innovación del conocimiento. *Visión Gerencial*. 18 (2): 235-253
  18. Hernández, T. J., Molina, H. D. y García, C. (2018). Governance in the organization mexican photovoltaic industry. *International Journal of Advanced, Engineering, Management and Science*. 4 (5). 1-16
  19. Hernández, T. J., Sánchez, A., Espinoza, F., Sánchez, R. y García, C. (2018). Modelo e lucidez, emprendimiento e innovación en microempresas caficadoras del centro de México. *Eureka*. 15 (1): 96-107
  20. Juárez, M., Espinoza, F., Sandoval, F. R., Hernández, J., Bustos, J. M. y Quintero, M. L. (2018). Contrastación de un modelo de isomorfismo educativo en una universidad pública del centro de México. *Aside*. 17 (1): 18-27
  21. Martínez, E., Sánchez, A., Quintero, M. L., Barrera, A., Llamas, B. y García, C. (2018). Contrastación exploratoria de un modelo de gestión del conocimiento. *Visión Gerencial*. 19 (1): 1-22
  22. Molina, H. D., García, C. y Rojano, S. M. (2018). Importance of managerial leadership in the organization: A reflection on a mexican photovoltaic industry thorough an empirical framework proposal. *International Journal for Advance Engineering, Management and Science*. 4 (5): 1-16
  23. Sánchez, A., Hernández, T. J., Martínez, E., Villegas, E. y García, C. (2018). Cultura organizacional en microempresas activadoras del conocimiento. *Margen*. 89 (1): 1-10
  24. Sánchez, A., Juárez, M., Bustos, J. M. y García, C. (2018). Contraste de un modelo de expectativas laborales en exmigrantes del centro de México. *Gestión de la Personas y Tecnología*. 32 (1): 21-36
  25. Sánchez, A., Juárez, M., Bustos, J. M., Fierro, E. y García, C. (2018). Confiabilidad y validez de una escala de gestión del conocimiento en una universidad pública del centro de México. *Cuadernos Hispanoamericanos de Psicología*. 17 (2). 1-12
  26. Sánchez, A., Molina, H. D., Carreón, J. y García, C. (2018). Contrastación de un modelo de formación laboral. *Interconectando Saberes*. 3 (5): 37-73
  27. Sánchez, R., Villegas, E., Sánchez, A., Espinoza, F. y García, C. (2018). Modelo para el estudio de la lucidez organizacional y la responsabilidad social corporativa. *Sincronía*. 22 (74): 467-483

28. Valdés, O., Quintero, M. L. y García, C. (2017). Complejización de un modelo de cultura laboral migrante. *Doxa*. 7 (13): 66-78
29. Villegas, E., García, C. y Hernández, T. J. (2018). Establecimiento de una política de ciencia y tecnología para la incubación de microempresas innovadoras del conocimiento. *Inclusiones*. 5 (1): 19-26
30. Villegas, E., Rosas, F. J. y García, C. (2018). Social work a towards quality of life and wellbeing subjective. *International Journal of Research in Humanities and Social Studies*. 5 (6): 35-48