

## Author's Accepted Manuscript

Set-up of a multi wavelength polar photometer for off-line absorption coefficient measurements on 1-hour resolved aerosol samples

Vera Bernardoni, Gianluigi Valli, Roberta Vecchi



PII: S0021-8502(16)30154-9  
DOI: <http://dx.doi.org/10.1016/j.jaerosci.2017.02.009>  
Reference: AS5110

To appear in: *Journal of Aerosol Science*

Received date: 9 May 2016  
Revised date: 9 December 2016  
Accepted date: 14 February 2017

Cite this article as: Vera Bernardoni, Gianluigi Valli and Roberta Vecchi, Set-up of a multi wavelength polar photometer for off-line absorption coefficient measurements on 1-hour resolved aerosol samples, *Journal of Aerosol Science* <http://dx.doi.org/10.1016/j.jaerosci.2017.02.009>

This is a PDF file of an unedited manuscript that has been accepted for publication. As a service to our customers we are providing this early version of the manuscript. The manuscript will undergo copyediting, typesetting, and a review of the resulting galley proof before it is published in its final citable form. Please note that during the production process errors may be discovered which could affect the content, and all legal disclaimers that apply to the journal pertain.

## Set-up of a multi wavelength polar photometer for off-line absorption coefficient measurements on 1-hour resolved aerosol samples

Vera Bernardoni<sup>1</sup>, Gianluigi Valli<sup>1</sup>, Roberta Vecchi<sup>1,\*</sup>

<sup>1</sup> Department of Physics, Università degli Studi di Milano & National Institute of Nuclear Physics, Milan, Italy

\* Corresponding author:

Prof. Roberta Vecchi

Università degli Studi di Milano, Department of Physics

Via Celoria 16, 20133 Milan (Italy)

mail: roberta.vecchi@unimi.it

tel: +39 02 50317498

### Abstract

In this paper, a polar photometer (PP\_UniMI) was set up to measure the aerosol absorption coefficient ( $\sigma_{ap}$ ) at four wavelengths ( $\lambda$ ) on 1-h resolved aerosol samples collected using a streaker sampler. Due to the characteristics of such samples (small deposit area, low aerosol load, and limited substrate thickness - 10 $\mu$ m), the main technical developments aimed at reaching suitable limits of detection (LODs). To this aim, multiple scattering between the sample and a suitable substrate were exploited to amplify the system sensitivity to absorbing particle load. In the paper, the development and test of this innovative approach is presented.

LODs for  $\sigma_{ap}$  in the range 5.0-11.6 Mm<sup>-1</sup> were reached, depending on the wavelength. Such values were suitable for the analysis of 1-hour resolved samples collected at an urban background site in Milan (Italy) during a test campaign of 1-week carried out in winter 2015. The methodology was validated comparing  $\sigma_{ap}$  measurements performed by PP\_UniMI at  $\lambda=635$ nm on the streaker sample to the data obtained by a Multi-Angle Absorption Photometer (MAAP) operated in parallel.

Agreement within 10% was found. To check the results obtained at other wavelengths, Ångström Absorption Exponent (AAE) was calculated from  $\sigma_{ap}$  measurements at 4- $\lambda$ . The AAE values resulted in the range of expectations for aerosol emitted by fossil fuel combustion (0.8-1.2) and wood burning (0.9-3.5), which are the main sources contributing to absorbing aerosol in urban areas in winter.

The analytical methodology can be extended to samples collected with high time resolution using other high-time resolution samplers (e.g. drum rotating impactors).

This is - as far as we know - the first time that  $\sigma_{ap}$  measurements are performed on streaker samples collected with 1-h resolution. Our results thus set PP\_UniMI as an important tool for the community performing high time resolved sampling to widen the characterisation of such samples and to further develop source apportionment studies.

**Keywords:** Aerosol optical absorption coefficient, multi- $\lambda$  absorption properties, high-time resolution measurements, source apportionment

## 1. Introduction

Atmospheric aerosol influences the Earth radiation balance by aerosol-radiation and aerosol-cloud interactions. Aerosol-radiation interactions are related to aerosol scattering and absorption properties, which depend on aerosol size distribution, refractive index, and mixing state. Black carbon (BC) is the main absorber of solar radiation among the aerosol components, influences cloud processes, and alters the melting of snow and ice cover. On global scale, it is currently identified as the third most important individual climate-warming component after CO<sub>2</sub> and CH<sub>4</sub>. Nevertheless, 90% uncertainty bounds for the radiative forcing related to BC-radiation interaction cover about one order of magnitude (IPCC, 2013).

Such large uncertainties are related e.g. to difficulties still present in BC quantification (Petzold et al., 2013) and in the evaluation of the effect of mixing state on BC absorption properties (Bond et al., 2013). Indeed, internal mixing and/or coating with transparent or weakly absorbing material (brown carbon, BrC) can strongly modify BC absorption properties (Lack and Cappa, 2013) although the quantification of such effects is still under debate (Knox et al., 2009; Cappa et al., 2012). BrC is another absorbing component in atmosphere. It is characterised by the increase of the imaginary part of the refractive index (i.e. the physical quantity related to light absorption) at lower wavelengths and further details on its properties are barely known. It is noteworthy that possible effects related to BC and BrC mixing are currently neglected in the climate modelling approaches (Wei et al., 2013).

As the mixing state affects aerosol absorption properties, it is important performing absorption measurements with no sample pre-treatment. To this aim, different approaches are currently used in the literature (Moosmüller et al., 2009): a) on-line measurements of aerosol in air - e.g. photo-acoustic instrumentation (Terhune and Anderson, 1977) or instrumentation based on incandescence (Melton, 1984); b) on-line measurements of aerosol collected on a filter - based either on

transmittance measurements (Hansen et al., 1984) or on both transmitted and scattered light (Petzold and Schölinner, 2004); c) off-line measurements of absorption properties - e.g. based on polar photometry (Hänel, 1994).

On-line instrumentation working in air is free from possible interactions (e.g. multiple scattering) between the aerosol and the collecting medium. Some drawbacks can however exist: e.g. the single-particle soot photometer (SP2) (Stephens et al., 2003) - a widely used instrument based on incandescence - allows to determine single particle size and absorption properties, but it currently works only at one wavelength ( $\lambda$ ), thus no information on the  $\lambda$ -dependence of aerosol absorption properties can be retrieved. Multi- $\lambda$  photoacoustic instrumentation was implemented (Ajtai et al., 2010) to perform the multi- $\lambda$  determination measurements of absorption optical properties.

However, it has to be considered that the heating provided during such measurements can lead to volatilisation of semi-volatile compounds affecting the obtained results (Moosmüller et al., 2009). As for filter measurements, multiple-scattering effects between the aerosol and the collecting medium have always to be considered both for on-line and off-line instrumentation. Furthermore, a possible influence of liquid-like or semi-volatile organics on the measurement of absorption properties of aerosol collected on fibre filters was evidenced (Lack et al., 2008, Vecchi et al., 2014). Among on-line filter-based instrumentation, the Multi-Angle Absorption Photometer (MAAP, Petzold and Schölinner, 2004) - measures both transmitted and scattered light and accounts for aerosol/filter multiple scatterings using a radiative transfer model. The major limitation of this instrument is that it operates at a single  $\lambda$ . On-line instrumentation based on transmittance measurement only is generally multi-wavelength - e.g. 7- $\lambda$  Aethalometer (Arnott et al., 2005), 3- $\lambda$  Particle Soot Absorption Photometer (PSAP) (Virkkula et al., 2005) - but requires correction algorithms to account for the scattering properties of the aerosol and/or parallel measurements of the scattering coefficient.

The advantage in performing off-line measurements through polar photometers is that non-destructive absorption measurements can be carried out on aerosol samples collected during routine monitoring campaigns without the need of co-located additional instrumentation. Indeed, instruments like the PP\_UniMI set up at the University of Milan (Vecchi et al., 2010; Vecchi et al., 2014) and the Multi-Wavelength Absorbance Analyser - MWAA (Massabò et al., 2013) developed at the University of Genoa were proved to provide information on the aerosol absorption coefficient ( $\sigma_{ap}$ ) of samples collected on different sampling media. These measurements can be used for optical source apportionment studies and can also allow retrospective studies on filters collected in the past and correctly stored.

Beside routinely collected 24-h samples, high-time resolution sampling using streaker samplers (Annegarn et al., 1988) or rotating drum impactors (Cahill et al., 1987) are performed all over the world (e.g. in recent years: Hahnenberger & Perry, 2015; Moreno et al., 2013; Pokornà et al., 2016, Trompeter et al., 2016). Such samplers provide size-segregated aerosol samples collected with high temporal resolution on rotating thin foils. Aerosol deposits are usually characterised for elemental concentration (Na-Pb) using different non-destructive techniques such as Particle-Induced X-Ray emission (Annegarn, 1987; Cahill, 1996; Calzolari et al., 2015), Energy-Dispersive X-Ray Fluorescence (Giannoni et al., 2015), Synchrotron Radiation X-Ray Fluorescence (Bukowiecki et al., 2005) or for organic/biological components (Wang et al., 2014). High-time resolved source apportionment studies have been performed typically using elemental composition (e.g. Barrera et al., 2015; Li et al., 2013; Taiwo et al., 2014, Crilley et al., 2017) or adding organic carbon speciation obtained using the Aerosol Mass Spectrometry (Richard et al., 2011) as parallel information. Extinction measurements were performed on samples collected using the DRUM (Davis Rotating drum Unit for Monitoring) impactor (Peré-Trepat et al., 2007) but at the best of our knowledge, no instrument has been developed yet to measure  $\sigma_{ap}$  on such samples.

It is worthy to note that the knowledge of  $\sigma_{ap}$  at different wavelengths extends the possibility of applying source apportionment approaches based on aerosol absorption properties, i.e.

Aethalometer model (Sandradewi et al., 2008) and MWAA model (Massabò et al., 2015) to streaker/drum samples. Furthermore, the chemical characterisation of high time resolved samples can be widened retrieving equivalent black carbon concentration (EBC) from  $\sigma_{ap}$  using a suitable Mass Absorption Coefficient (Petzold et al., 2013)). Indeed, EBC is a recognised tracer for traffic exhaust contribution used in source apportionment studies based on chemical speciation.

In this work, PP\_UniMI implementation was two-fold:

- a) the set-up presented in Vecchi et al. (2014) was upgraded to provide 4- $\lambda$  measurements of the absorption coefficient of aerosol collected both on 47 mm diameter filters;
- b) a set-up to analyse 1-h resolution streaker samples was implemented. It has to be taken into account that the thinness (10 $\mu$ m) of the streaker support required the development of an innovative methodology to increase the sensitivity of the technique. The experimental methodology was validated at  $\lambda=635$ nm against MAAP measurements performed in parallel to the sampling by the streaker. Ångström absorption coefficient estimate was used as indication of the reliability of the measurements obtained at other wavelengths. It is noteworthy that at the best of our knowledge no other instrumentation performing absorption measurements on 1-h resolved samples from streaker or DRUM impactors exists; thus our methodology provides new frontiers to the community using such samplers.

## 2. Materials and Methods

### 2.1 Instrumentation and sampling campaign

#### 2.1.1 The streaker sampler and the test campaign

The streaker sampler separates particles in two different size-fractions using a pre-impactor (which removes particles with aerodynamic diameter  $d_{ae} > 10 \mu\text{m}$ ) and an impactor. The impactor is a polypropylene foil  $2.5 \mu\text{m} < d_{ae} < 10 \mu\text{m}$  on which coarse particles are deposited. The fine fraction ( $d_{ae} < 2.5 \mu\text{m}$ ) is then collected on a polycarbonate filter (0.4  $\mu\text{m}$  pore diameter, 10  $\mu\text{m}$  thickness). The polypropylene foil and polycarbonate filter (streaker frames) are paired in a cartridge rotating at  $1.8^\circ \text{h}^{-1}$ , corresponding to a  $1.25 \times 8 \text{ mm}^2$  hourly streak. One-week sampling (corresponding to 168 hourly streaks) is performed on the same pair of frames. Sampling is performed at a flow-rate of 1 l/min. Further details on the sampler, its cut-off diameters, and its control unit can be found elsewhere (Prati et al., 1998).

A 1-week sampling campaign was performed in Milan (Italy) at an urban background site in the period 16-24 November 2015. Due to technical problems, sampling was not performed in the nights of 19-20 and 20-21 November. A Foehn event occurred on the evening of Saturday 21 November and lasted about 20 hours. The aerosol fine fraction collected with 1-hour temporal resolution on the polycarbonate filter was used to test the methodology developed for the  $\sigma_{ap}$  measurement (section 3).

#### 2.1.2 The polar photometer

In this section, an evolution of the PP\_UniMI instrument described in Vecchi et al. (2014) is presented.

For the analysis of 47-mm filters, 4 laser sources at 405nm (World Star Tech, 10mW), 532nm (Thorlabs, CPS532, 4.5mW), 635nm (Thorlabs, CPS192, 4.5mW), and 780nm (Thorlabs, CPS196, 4.5mW) are mounted on a sliding motor. The chosen laser beam impinges directly on the sample deposit. The area of the beam spot is in the range  $5\text{-}10 \text{ mm}^2$ , allowing to account for possible local non-homogeneities in the sample deposit. For the analysis of streaker samples, 4 dedicated laser sources at 405nm (World Star Tech, 10mW), 532nm (Thorlabs, CPS532, 4.5mW), 635nm (World Star Tech, 10mW), and 780nm (Thorlabs, CPS196, 4.5mW) are mounted at  $90^\circ$  in respect to the sources for 47-mm filters and impinge on the sample after  $90^\circ$  deflection performed through suitable removable mirrors in the system (405nm, 532 nm, 780 nm, see figure 1).

The laser intensity monitoring at the beginning and at the end of each measurement session is used to normalise measurements to a reference value. This avoids influences from long term instabilities

evaluated in 1% at 635nm and 780nm, 4% at 405nm, and 9% at 532nm. Opposite, short-term (intra-day) laser variability is better than 0.7% at all wavelengths except 532nm, for which it is about 3% (this is included in the measurement uncertainties).

The radiation scattered by the sample is focused by a lens on an amplified photodetector (Thorlabs PDA36A-EC, active area = 13 mm<sup>2</sup>); the focusing lens allows the accurate selection of the scattering angle where the measurement is performed. The photodetector is mounted on a rotating arm whose rotation centre coincides with the sample under analysis. It performs measurements of the light intensity on the scattering plane, with about 0.4° resolution from 0° to 173°, allowing the reconstruction (i.e. solid-angle integration) of the amount of light scattered in the two hemispheres. A home-made LabView software controls: (1) the movement of the rotating arm operated by a stepping motor; (2) the automated sample change (up to seven 47-mm filters or 168 streaks); (3) data acquisition performed by a Data Acquisition System (National Instrument, USB 6221). The reconstruction of the total amounts of light scattered in the forward and in the backward hemispheres by the blank filter and by the sample+filter system (loaded filter) is performed by PP\_UniMI measurements through solid-angle integration. These quantities are used as inputs for the radiative transfer model – based on two stream approximation (Coakley and Chylek, 1975) – reported in Hänel (1987) and Hänel (1994) for membrane filters and extended by Petzold and Schöllner (2004) for quartz fibre filters to obtain the aerosol absorption optical depth (ABS) of the sample. The aerosol absorption coefficient ( $\sigma_{ap}$  in Mm<sup>-1</sup>) is then calculated from ABS considering the area of the deposit (A) and the sampled volume (V) as:  $\sigma_{ap} = \text{ABS} \frac{A}{V}$ . The PP\_UniMI limits of detection for aerosol collected on 47-mm PTFE filters are reported in table 1. The uncertainties on ABS were evaluated to be about  $\pm 0.01$  for  $\text{ABS} < 0.1$  and  $\pm 10\%$  for higher ABS values at all wavelengths but 532 nm, for which they are higher due to short-term laser instability (0.013 for  $\text{ABS} < 0.1$  and  $\pm 13\%$  for higher ABS values). They account for short-term laser variability, detector noise, filter re-positioning, sample inhomogeneities and analysis repeatability.

The system was validated for measurements carried out at  $\lambda = 635$  nm on quartz fibre filters against Multi-Angle Absorption Photometer (MAAP) measurements in Vecchi et al. (2014). In the same work, it was also demonstrated that measurements on PTFE and quartz-fibre filters give equivalent results, provided that organic sampling artefacts on quartz fibre filters are avoided.

### 2.1.3 Multi Angle Absorption Photometer (MAAP)

The Multi Angle Absorption Photometer (MAAP, mod. 5012 Thermo Scientific) simultaneously measures the optical transmission and scattering of light by the aerosol collected on a glass-fibre filter tape to determine EBC content. The MAAP ( $\lambda = 637 \pm 1$  nm, Müller et al., 2011) reconstructs

the light distribution in the forward and backward hemispheres from measurements of light transmitted and scattered at three fixed angles properly selected, using suitable analytical functions (Petzold and Schölinner, 2004). The output of the instrument is the atmospheric equivalent black carbon (EBC) concentration (in  $\mu\text{g}/\text{m}^3$ ) (Petzold et al., 2013), which is obtained from  $\sigma_{\text{ap}}$  considering the deposit area and sampling air flow, and setting at  $6.6 \text{ m}^2/\text{g}$  the EBC mass-specific absorption coefficient (Petzold et al., 2002). Details on the instrument performance can be found in Müller et al. (2011).

The MAAP and PP\_UniMI are based on the same measuring principle as both determine  $\sigma_{\text{ap}}$  from information on the light distribution in the forward and backward hemispheres measured on a blank and aerosol loaded filter and use the same radiative transfer scheme mentioned in par. 2.1.2.

Therefore, the MAAP was used to validate the  $\sigma_{\text{ap}}$  measurements carried out using PP\_UniMI on the aerosol collected with 1-h resolution using the streaker sampler.

Two biases may affect MAAP data: the first occurs at high EBC concentration as pointed out by Hyvärinen et al. (2013); the second one is related to the possible impact on optical measurements of sampling artefacts due to organics on fibre filters as reported in Vecchi et al. (2014). Therefore, in this work MAAP data were corrected for both biases according to what reported in the previous mentioned literature works.

#### *2.1.4 Ancillary measurements*

PM10 and PM2.5 samples were collected in parallel to the streaker sampling using low-volume samplers (flowrate =  $2.3 \text{ m}^3/\text{h}$ ) on 47mm diameter PTFE filters (PallFlex RPJ047) during November 2015.

#### *2.2 PP\_UniMI implementation for streaker sample measurements*

The main scope of this work was implementing PP\_UniMI to perform multi- $\lambda$   $\sigma_{\text{ap}}$  measurements on samples collected with 1-h temporal resolution using a streaker sampler. The main problems to be faced in this kind of analysis are related to the limited width (1.25 mm) of a single streak and the low aerosol load on the thin polycarbonate filter related to 1-h resolution. Thus, methodologies to improve the sensitivity of PP\_UniMI were developed to reach suitable limits of detection (LODs).

##### *2.2.1. Step 1: beam collimation*

The laser sources have different shape (circular or elliptical) and size (up to 4.5 mm major axis) of the beam spot. To collimate the incident spot down to about 1 mm diameter limiting beam power losses, pairs of lenses with suitable focal lengths were chosen using geometric optics calculations.



The objective was reducing the beam width of about a factor 4 in order to have a maximum size of about 1 mm. The final choice was the use of two lenses of 10 cm and 2.5 cm focal lengths displaced at 12.5 cm distance. In this way, a parallel beam of about 1 mm maximum size was obtained for all sources. Moreover, a 1-mm diameter collimator was used to ensure the correct size of the spot on the streaker support (see figure 2).

This approach allowed working with about 80% of the total laser power (please note that the use of lenses leads to a light loss of about 10% for each lens due to reflection) reaching LODs for ABS of about 0.06-0.15 depending on the wavelength. However, measurements on the streaker sample showed that ABS was still below the LODs in 46-64% of the measured points/streaks (depending on the wavelength) thus limiting the possibility of determining  $\sigma_{ap}$  on 1-h samples.

### *2.2.2 Step 2: Radiative transfer model response to multiple scattering enhancement.*

An innovative methodology based on exploiting multiple scattering between the sample and the collecting substrate was tested to improve the technique sensitivity to overcome the limitations reported above. Amplification of multiple scattering effects between the aerosol and the collecting medium was carried out leaning the aerosol sampled filter against a fibre filter (called SFF system in the following) aiming at enhancing light absorption effects. This allowed a higher fraction of light to be backscattered by the substrates, thus increasing the probability of interaction between the light and the absorbing particles and enhancing the technique sensitivity (see conceptual scheme in figure 3).

The response of the radiative transfer model to the variation of multiple scattering effects between the sample and the substrate was tested using the samples collected on 47-mm PTFE filters mentioned in par. 2.1.4. Indeed, these filters are 46 $\mu$ m thick, they scatter in the back hemisphere a fraction of light about 40% higher than polycarbonate filters and good LODs (table 1) can be obtained by the analysis of the PTFE filter as-is, as already mentioned in par. 2.1.2. The 4- $\lambda$  measurements using PP\_UniMI were performed both on samples collected on the PTFE filter as-is and with the SFF system. In both cases, the radiative transfer model cited in par 2.1.2 was applied to determine ABS. It can be noticed in figure 4a that leaning the PTFE filter against a fibre filter modifies the light distribution between the front and backward hemispheres, but this is not an issue with PP\_UniMI as it measures the phase function in the whole scattering plane. It is interesting to note that very good correlation ( $R=0.99$ ) was found between the two approaches as shown in figure 4b where the scatterplot of ABS measured at 4- $\lambda$  is reported. Due to similarities of statistical regression parameters at the different wavelengths, a unique Deming regression was performed on the whole dataset, assuming comparable error variances for the data measured on the samples

collected on the PTFE filter as-is and for the SFF system. The slope (0.97) of the Deming regression line is comparable to 1 with a confidence level of 0.5 and the intercept (1.18) is comparable to 0 within a 0.4 confidence level, confirming the ability of the radiative transfer model to account for multiple scattering effects between the sample and the substrate correctly, independently on the substrate thickness.

### 3. Results and Discussion

#### 3.1 Evaluation of the new methodology performance on the 1-h resolved sample.

Results reported in par. 2.2.2 show that the radiative transfer model applied to transmitted and scattered light is able to retrieve ABS independently on the extent of multiple scattering effects. Thus, measurements of optical absorption properties of the fine fraction collected by the streaker sampler on the polycarbonate filter were carried out using the SFF system. A fibre filter was suitably shaped and leaned against the polycarbonate filter to modify the light distribution in the two hemispheres as described in par. 2.2.2 (see figure 5a). In order to check the performance of the proposed methodology, in this work measurements were carried out both on the aerosol sample deposited on the polycarbonate filter as-is and on the SFF system. The LODs for aerosol ABS measured using the streaker SFF system were reduced at about 0.03-0.07 (comparable to those obtained on PTFE filters corresponding to a minimum  $\sigma_{ap}$  in the range 5-11.6  $Mm^{-1}$  for streaker samples), depending on the wavelength (see table 2).

When comparing the two approaches, it has to be noticed that the number of available data using the SFF system was in the range 77-94% depending on  $\lambda$ . It has to be recalled that the number of available data when analysing the polycarbonate streaker frame as-is was between 46% and 64% (depending on  $\lambda$ ). Thus, the reduction of LODs obtained with the new SFF system strongly increases the number of valid data, being the crucial step to perform measurements on 1-h resolved streaker samples. In figure 5b, the scatterplot of the points available with both methods is shown. The correlation coefficient between the two measurement approaches was relatively low (in the range 0.51-0.79 depending on the wavelength, being 0.75 for the whole dataset), probably due to the reduced sensitivity of PP\_UniMI in the analysis of the polycarbonate filter as-is.

#### 3.2 Validation of the SFF system for streaker samples by comparison to MAAP

No certified material of aerosol absorption coefficient is currently available (Baumgardner et al., 2013). Thus, the results obtained with the SFF system were validated against external measurements, carried out using a MAAP operating in parallel to the streaker sampler. The MAAP operates at 637 nm, thus the measurements carried out with PP\_UniMI at 635 nm on the streaker

polycarbonate SFF system were used for the comparison. The  $\sigma_{ap}$  measured by the MAAP and by PP\_UniMI on 1-h streaker samples using the SFF system were compared and the results are shown in figure 6a. The agreement between the techniques is within 10%, the intercept of the regression line is comparable to zero within uncertainties and the correlation coefficient between the measurements is high ( $R=0.93$ ). Comparing the  $\sigma_{ap}$  temporal trends measured by the two instruments (figure 6b), it is noteworthy that the LODs reached using PP\_UniMI on the streaker SFF system allowed the measurement of  $\sigma_{ap}$  at the sampling site during the whole test campaign, except for the Foehn event between 21<sup>th</sup> November h.19.00 and 22<sup>nd</sup> November h.15.00, when the MAAP reported EBC concentration in the range 0.25-0.82  $\mu\text{g m}^{-3}$ , corresponding to a  $\sigma_{ap}=1.8\text{-}5.0 \text{ Mm}^{-1}$  at  $\lambda = 635 \text{ nm}$ .

### 3.3 Ångström Absorption Coefficients

The  $\sigma_{ap}$  temporal trends measured at 4- $\lambda$ s on 1-h streaker samples by PP\_UniMI using the SFF system are presented in figure 7 (lines).

No external multi- $\lambda$  instrumentation was available for PP\_UniMI validation at wavelengths other than 635 nm. Therefore, to check the reliability of our system at all available wavelengths the Ångström Absorption Exponent ( $\alpha$ ) was calculated for all samples and compared to values expected for an urban aerosol. To this aim, assuming  $\sigma_{ap} \sim \lambda^{-\alpha}$ ,  $\alpha$  was determined for each sample from 4- $\lambda$   $\sigma_{ap}$  measurements using non-linear least squares estimate. Interpolation was carried out only for samples for which  $\sigma_{ap}$  was available at all wavelengths (110 samples).

Literature  $\alpha$  values depend on the aerosol emission source; indeed,  $\alpha$  is reported to be in the range 0.8-1.2 (Gyawali et al., 2012; Ajtai et al., 2015; Zotter et al., 2016) for fossil fuel emissions and in the range 0.9-3.5 for wood burning aerosol (Kirchstetter and Thatcher, 2012; Harrison et al., 2013; and therein cited literature). Recently, Massabò et al. (2015) set  $\alpha=1.8$  for the wood burning aerosol in Italy in a source apportionment study.

In our samples,  $\alpha$  was found to be in the range 0.8-1.8 (figure 7, histogram), except few samples (about 10%). Fossil fuel combustion and wood burning are the main sources expected to contribute to absorbing aerosol in Milan during wintertime (Bernardoni et al., 2011; Bernardoni et al., 2013). These results and the validation presented in the par. 3.2 show that the newly developed set-up for the multi- $\lambda$  measurement of  $\sigma_{ap}$  on 1-h resolved streaker samples is reliable.

## 4. Conclusions

Off-line multi- $\lambda$  absorption measurements of aerosol collected on filter media allow: a) the determination of optical absorption coefficient ( $\sigma_{ap}$ ) of aerosol collected during monitoring/research

campaign at different sites, with no need of additional instrumentation; b) source apportionment studies; c) retrospective studies using properly stored filters. Furthermore, using a suitable mass absorption coefficient, also EBC information can be provided from  $\sigma_{ap}$ .

This kind of measurements can be of particular interest for the analysis of high time resolved samples (collected e.g. by streaker sampler or DRUM impactor), whose characterisation is generally limited to elemental composition. Up to now, at the best of our knowledge, no instrumentation aiming at the multi-wavelength determination of the aerosol absorption coefficient on samples collected with high temporal resolution has been developed.

In this work, a laboratory instrument (PP\_UniMI) was implemented to perform 4- $\lambda$  measurements of the absorption coefficient of aerosol collected on 47 mm filters and on high-time resolved samples collected using a streaker sampler.

Due to the peculiarity of the polycarbonate substrate used for PM<sub>2.5</sub> collection in the streaker sampler (thickness about 10 $\mu$ m) and the low aerosol load related to 1-h sampling, an innovative methodology based on the amplification of multiple scattering effects between the sample and the collecting medium was developed to improve PP\_UniMI sensitivity to allow sample analysis. The methodology was applied during a test sampling campaign carried out in Milan urban area. It was demonstrated that amplifying multiple scattering effects to enhance PP\_UniMI sensitivity was the key step allowing the measurement of  $\sigma_{ap}$  in high time resolved samples. The methodology was validated for  $\lambda = 635$  nm against independent measurements carried out using a MAAP.

Furthermore, the values obtained for the Ångström Absorption Exponent in our samples was in the range expected for aerosol emitted by fossil fuel combustion and wood burning, thus proving the reliability of  $\sigma_{ap}$  measurements carried out by PP\_UniMI at wavelengths other than 635 nm.

Our results thus set PP\_UniMI as an important tool for the community using streaker or DRUM samplers to widen the characterisation of such samples.

As perspectives, multi- $\lambda$  high-time resolved measurements can be important in source apportionment studies. First of all, models (Aethalometer model (Sandradewi et al., 2008)) or (MWAA model (Massabò et al., 2015)) based on  $\sigma_{ap}$  source apportionment can be applied. Secondly, an evaluation of EBC from  $\sigma_{ap}$  measurements using a suitable mass-absorption coefficient can provide a useful chemical tracer to be added to the elemental characterisation usually carried out on 1-h resolved samples to perform receptor modelling based on the mass of chemical components (e.g. Multilinear Engine), also in multi-time modelling applications (Zhou et al., 2004, Crespi et al., 2016).

## 5. Acknowledgements

This work was partially funded in the frame of the INFN-DEPOTMASS experiment (DEtermining Particulate Organic and Total Mass in Aerosol Streaker Samples). The authors acknowledge prof. Paolo Prati and dr. Dario Massabò (Dept. of Physics, Università degli Studi di Genova) and the group on the LABEC-INFN (Florence) for fruitful scientific discussions. The authors are grateful to dr. Simone Ceriani and dr. Sara Valentini for collaboration.

Accepted manuscript

**References**

- Ajtai, T., Filep, Á., Schnaiter, M., Linke, C., Vragel, M., Bozóki, Z., Szabó, G., & Leisner, T. (2010). A novel multi-wavelength photoacoustic spectrometer for the measurement of the UV–vis–NIR spectral absorption coefficient of atmospheric aerosols. *Journal of Aerosol Science*, *41*, 1020–1029.
- Ajtai, T., Utry, N., Pintér, M., Major, B., Bozóki, Z., Szabó, G. (2015). A method for segregating the optical absorption properties and the mass concentration of winter time urban aerosol. *Atmospheric Environment*, *122*, 313–320
- Annegarn, H.J. (1987). Time-series analysis of PIXE aerosol measurements. *Nuclear Instruments & Methods in physics research section B - beam interactions with materials and atoms*, *22*, 270–274.
- Annegarn, H.J., Cahill, T.A., Sellschop, J.F.P., & Zucchiatti, A. (1988). Time sequence particulate sampling and nuclear analysis. *Physics Scripta*, *37*, 282–290.
- Arnott, W.P., Hamasha, K., Moosmüller, H., Sheridan, P. J., & Ogren, J.A. (2005). Towards aerosol light-absorption measurements with a 7-wavelength aethalometer: evaluation with a photoacoustic instrument and 3-wavelength nephelometer. *Aerosol Science and Technology*, *39*, 17–29.
- Barrera, V., Calzolari, G., Chiari, M., Lucarelli, F., Nava, S., Giannoni, M., Becagli, S., & Frosini, D. (2015). Study of air pollution in the proximity of a waste incinerator. *Nuclear Instruments and Methods in Physics Research B*, *363*, 112–118.
- Baumgardner, D., Popovicheva, O., Allan, J., Bernardoni, V., Cao, J., Cavalli, F., Cozic, J., Diapouli, E., Eleftheriadis, K., Genberg, P. J., Gonzalez, C., Gysel, M., John, A., Kirchstetter, T. W., Kuhlbusch, T. A. J., Laborde, M., Lack, D., Müller, T., Niessner, R., Petzold, A., Piazzalunga, A., Putaud, J. P., Schwarz, J., Sheridan, P., Subramanian, R., Swietlicki, E., Valli, G., Vecchi, R., & Viana, M. (2012). “Soot Reference Materials for instrument calibration and intercomparisons: a workshop summary with recommendations”. *Atmospheric Measurements Techniques*, *5*, 1869–1887.
- Bernardoni, V., Vecchi, R., Valli, G. Piazzalunga, A., & Fermo, P. (2011). PM10 source

apportionment in Milan (Italy) using time-resolved data. *The Science of the Total Environment*, 409, 4788-4795.

Bernardoni, V., Calzolari, G., Chiari, M., Fedi, M., Lucarelli, F., Nava, S., Piazzalunga, A., Riccobono, F., Taccetti, F., Valli, G. & Vecchi, R. (2013). Radiocarbon analysis on organic and elemental carbon in aerosol samples and source apportionment at an urban site in Northern Italy. *Journal of Aerosol Science*, 56, 88–99.

Bond, T. C., Doherty, S. J., Fahey, D. W., Forster, P. M., Berntsen, T., DeAngelo, B. J., Flanner, M. G., Ghan, S., Kärcher, B., Koch, D., Kinne, S., Kondo, Y., Quinn, P. K., Sarofim, M. C., Schultz, M. G., Schulz, M., Venkataraman, C., Zhang, H., Zhang, S., Bellouin, N., Guttikunda, S. K., Hopke, P. K., Jacobson, M. Z., Kaiser, J. W., Klimont, Z., Lohmann, U., Schwarz, J. P., Shindell, D., Storelvmo, T., Warren, S. G., & Zender, C. S. (2013). Bounding the role of black carbon in the climate system: A scientific assessment. *Journal of Geophysical Research: Atmospheres*, 118, 5380-5552.

Bukowiecki, N., Hill, M., Gehrig, R., Lienemann, P., Zwicky, C. N., Hegedüs, F., Falkenberg, G., Weingartner, E., & Baltensperger, U., (2005). Trace metals in ambient air: hourly size segregated mass concentrations determined by synchrotron-XRF. *Environmental Science and Technology*, 39, 5754–5762.

Calzolari, G., Lucarelli, F., Chiari, M., Nava, S., Giannoni, M., Carraresi, L., Prati, P., & Vecchi, R. (2015). Improvements in PIXE analysis of hourly particulate matter samples. *Nuclear Instruments and Methods in Physics Research B*, 363, 99-104.

Cahill, T. A., Goodart, C., Nelson, J. W., Eldred, R. A., Nasstrum, J. S., & Feeney, P. J. (1987). Design and evaluation of the DRUM impactor. In: Ariman, T., Veziroglu, T.N. (Eds.), *Particulate and Multiphase Processes, Vol. 2, Contamination Analysis and Control* (pp. 319–325). Hemisphere Publishing Corporation, Washington, DC, USA.

Cahill, T.A. (1996). Climate Forcing by Anthropogenic Aerosols: The Role for PIXE, *Nuclear Instruments and Methods in Physics Research B: Beam Interactions with Materials and Atoms*, 109/110, 402-406.

Cappa, C. D., Onasch, T. B., Massoli, P., Worsnop, D. R., Bates, T. S., Cross, E. S., Davidovits, P., Hakala, J., Hayden, K. L., Jobson, B. T., Kolesar, K. R., Lack, D. A., Lerner, B. M., Li, S.-M., Mellon, D., Nuaaman, I., Olfert, J. S., Petäjä, T., Quinn, P. K., Song, C., Subramanian, R., Williams, E. J., & Zaveri, R. A. (2012). Radiative Absorption Enhancements Due to the Mixing State of Atmospheric Black Carbon. *Science*, *337*, 1078-1081.

Coakley, J. A. Jr., & Chylek, P. (1975). The Two-Stream Approximation in Radiative Transfer: Including the Angle of the Incident Radiation. *Journal of the Atmospheric Sciences*, *32*, 409-418

Crespi, A., Bernardoni, V., Calzolari, G., Lucarelli, F., Nava, S., Valli, G., & Vecchi, R. (2016). Implementing constrained multi-time approach with bootstrap analysis in ME-2: An application to PM<sub>2.5</sub> data from Florence (Italy). *Science of the Total Environment*, *541*, 502-511.

Crilley, L. R., Lucarelli, F., Bloss, W.J., Harrison, R.M., Beddows D.C., Calzolari G., Nava S., Valli G., Bernardoni V. & Vecchi R. (2017). Source apportionment of fine and coarse particles at a roadside and urban background site in London during the 2012 summer ClearLo campaign. *Environmental Pollution*, *220*, 766-778

Giannoni, M., Calzolari, G., Chiari, M., Lucarelli, F., Mazzinghi, A., Nava, S., & Ruberto, C. (2015). Feasibility study of ED-XRF analysis of atmospheric particulate matter samples collected with high time resolution. *X-Ray Spectrometry*, *44*, 282-288.

Gyawali, M., Arnott, W. P., Zaveri, R. A., Song, C., Moosmüller, H., Liu L., Mishchenko, M. I., Chen, L.-W. A., Green, C., Watson, J. G., & Chow, J. C. (2012). Photoacoustic optical properties at UV, VIS, and near IR wavelengths for laboratory generated and winter time ambient urban aerosols. *Atmospheric Chemistry and Physics*, *12*, 2587-2601

Hänel, G. (1987). Radiation budget of the boundary layer: Part II. Simultaneous measurement of mean solar volume absorption and extinction coefficients of particles. *Beiträge zur Physik der Atmosphäre*, *60*, 241-247.

Hänel, G. (1994). Optical properties of atmospheric particles: Complete parameter sets obtained through polar photometry and an improved inversion technique. *Applied Optics*, *33*, 7187-7199.



Hahnenberger M., & Perry K.D. (2015). Chemical comparison of dust and soil from the Sevier Dry Lake, UT, USA. *Atmospheric Environment*, *113*, 90 – 97.

Hansen, A.D.A., Rosen, H. & Novakov, T. (1984). The aethalometer—an instrument for the real-time measurement of optical absorption by aerosol particles. *The Science of the Total Environment*, *36*, 191–196.

Harrison, R.M., Beddows, D.C.S., Jones, A.M., Calvo, A., Alves, C. & Pio, C. (2013). An evaluation of some issues regarding the use of aethalometers to measure woodsmoke concentrations. *Atmospheric Environment*, *80*, 540-548

Hyvärinen, A.-P., Vakkari, V., Laakso, L., Hooda, R. K, Sharma, V. P., Panwar, T. S., Beukes, J. P., van Zyl, P., Josipovic, M., Garland, R. M., Andreae, M. O., Pöschl, U., & Petzold, A. (2013). Correction for a measurement artifact of the Multi-Angle Absorption Photometer (MAAP) at high black carbon mass concentration levels. *Atmospheric Measurement Techniques*, *6*, 81-90.

IPCC (2013). Climate Change 2013: The Physical Science Basis. Contribution of Working Group I to the Fifth Assessment Report of the Intergovernmental Panel on Climate Change [Stocker, T.F., D. Qin, G.-K. Plattner, M. Tignor, S.K. Allen, J. Boschung, A. Nauels, Y. Xia, V. Bex and P.M. Midgley(eds.)]. Cambridge University Press, Cambridge, United Kingdom and New York, NY, USA, 1535 pp.

Kirchstetter, T. W. & Thatcher, T. L. (2012). Contribution of organic carbon to wood smoke particulate matter absorption of solar radiation. *Atmospheric Chemistry and Physics*, *12*, 6067–6072

Knox, A., Evans, G. J., Brook, J. R., Yao, X., Jeong, C. -H., Godri, K. J., Sabaliauskas, K., & Slowik, J. G. (2009). Mass Absorption Cross-Section of Ambient Black Carbon Aerosol in Relation to Chemical Age. *Aerosol Science and Technology*, *43*, 522-532.

Lack, D. A., Cappa, C. D., Covert, D. S., Baynard, T., Massoli, P., Sierau, B., Bates, T. S., Quinn, P. K., Lovejoy, E. R., and Ravishankara, A. R.: Bias in filter-based aerosol light absorption measurements due to organic aerosol loading: Evidence from ambient measurements, *Aerosol Science and Technology*, *42*, 1033-1041, doi: 10.1080/02786820802389277, 2008

Lack, D. A., & Cappa, C. D. (2013). Impact of brown and clear carbon on light absorption enhancement, single scatter albedo and absorption wavelength dependence of black carbon. *Atmospheric Chemistry and Physics*, *10*, 4207–4220.

Li, N., Hopke, P. K., Kumar, P., Cliff, S.S., Zhao, Y., & Navasca, C. (2013). Source apportionment of time- and size-resolved ambient particulate matter. *Chemometrics and Intelligent Laboratory Systems*, *129*, 15-20.

Massabò, D., Bernardoni, V., Bove, M.C., Brunengo, A., Cuccia, E., Piazzalunga, A., Prati, P., Valli, G., & Vecchi, R., (2013). A multi-wavelength optical set-up for the characterization of carbonaceous particulate matter. *Journal of Aerosol Science*, *60*, 34-46.

Massabò, D., Caponi, L., Bernardoni, V., Bove, M. C., Brotto, P., Calzolari, G., Cassola, F., Chiari, M., Fedi, M. E., Fermo, P., Giannoni, M., Lucarelli, F., Nava, S., Piazzalunga, A., Valli, G., Vecchi, R., & Prati, P. (2015). Multi-wavelength optical determination of black and brown carbon in atmospheric aerosols. *Atmospheric Environment*, *108*, 1-12.

Melton, L. A. (1984). Soot diagnostic based on laser heating. *Applied Optics*, *23*, 2201–2208.

Moosmüller, H., Chakrabarty, R. K., & Arnott, W. P. (2009). Aerosol light absorption and its measurement: A review. *Journal of Quantitative Spectroscopy and Radiative Transfer*, *110*, 844-878.

Moreno T., Kojima T., Amato F., Lucarelli F., de la Rosa J., Calzolari G., Nava S., Chiari M., Alastuey A., Querol X., & Gibbons W. (2013). Daily and hourly chemical impact of springtime transboundary aerosols on Japanese air quality. *Atmospheric Chemistry and Physics*, *13*, 1411-1424

Müller, T., Henzing, J. S., de Leeuw, G., Wiedensohler, A., Alastuey, A., Angelov, H., Bizjak, M., Collaud Coen, M., Engström, J. E., Gruening, C., Hillamo, R., Hoffer, A., Imre, K., Ivanow, P., Jennings, G., Sun, J. Y., Kalivitis, N., Karlsson, H., Komppula, M., Laj, P., Li, S.-M., Lunder, C., Marinoni, A., Martins dos Santos, S., Moerman, M., Nowak, A., Ogren, J. A., Petzold, A., Pichon, J. M., Rodriguez, S., Sharma, S., Sheridan, P. J., Teinilä, K., Tuch, T., Viana, M., Virkkula, A., Weingartner, E., Wilhelm, R., & Wang, Y.Q. (2011). Characterization and intercomparison of

aerosol absorption photometers: result of two intercomparison workshops. *Atmospheric Measurement Techniques*, 4, 245–268.

Peré-Trepat, E., Kim, E., Paatero, P., & Hopke, P.K. (2007). Source apportionment of time and size resolved ambient particulate matter measured with a rotating DRUM impactor. *Atmospheric Environment*, 41, 5921–5933.

Petzold, A., Kramer, H., & Schönlinner, M. (2002). Continuous measurement of atmospheric black carbon using a multi-angle absorption photometer. *Environmental Science and Pollution Research* 4, 78–82.

Petzold, A. & Schönlinner, M. (2004). Multi-angle absorption photometry—a new method for the measurement of aerosol light absorption and atmospheric black carbon. *Journal of Aerosol Science*, 35, 421–441.

Petzold, A., Ogren, J. A., Fiebig, M., Laj, P., Li, S.-M., Baltensperger, U., Holzer-Popp, T., Kinne, S., Pappalardo, G., Sugimoto, N., Wehrli, C., Wiedensohler, A., & Zhang, X.-Y. (2013). Recommendations for reporting "black carbon" measurements. *Atmospheric Chemistry and Physics*, 13, 8365–8379.

Pokorná P., Hovorka J., & Hopke P. K. (2016). Elemental composition and source identification of very fine aerosol particles in a European air pollution hot-spot. *Atmospheric Pollution Research*, 7, 671–679

Prati, P., Zucchiatti, A., Tonus, S., Lucarelli, F., Mandò, P. A., & Ariola, V. (1998). A testing technique of streaker aerosol samplers via PIXE analysis. *Nuclear Instruments & Methods in Physics Research Section B-Beam Interactions With Materials and Atoms*, 136–138, 986–989.

Richard, A., Gianini, M. F. D., Mohr, C., Furger, M., Bukowiecki, N., Minguillón, M. C., Lienemann, P., Flechsig, U., Appel, K., DeCarlo, P. F., Heringa, M. F., Chirico, R., Baltensperger, U., & Prévôt, A. S. H. (2011). Source apportionment of size and time resolved trace elements and organic aerosols from an urban courtyard site in Switzerland. *Atmospheric Chemistry and Physics*, 11, 8945–8963.

Sandradewi, J., Prévôt, A.S., Szidat, S., Perron, N., Alfarra, M.R., Lanz, V.A., Weingartner, E., & Baltensperger, U. (2008). Using aerosol light absorption measurements for the quantitative determination of wood burning and traffic emission contributions to particulate matter. *Environmental Science and Technology*, 42, 3316-3323.

Stephens, M., Turner, N., & Sandberg J. (2003). Particle identification by laser-induced incandescence in a solid-state laser cavity. *Applied Optics*, 42, 3726-3736.

Taiwo, A.M., Beddows, D.C.S., Calzolari, G., Harrison, R. M., Lucarelli, F., Nava, S., Shi, Z., Valli, G., Vecchi, R. (2014). Receptor modelling of airborne particulate matter in the vicinity of a major steelworks site. *The Science of the Total Environment*, 490, 488-500.

Terhune, R.W., & Anderson, J.E. (1977). Spectrophone measurements of the absorption of visible light by aerosols in the atmosphere. *Optics Letters*, 1, 70-72.

Trompeter W. J., Ancelet T., Davy P. K., Kennedy J. (2016). Fugitive emissions from nanopowder manufacturing. *Journal of Nanoparticle Research*, 18, 203

Vecchi, R., Bernardoni, V., Broccoletti, S., Canepa, P., Cuccia, E., Massabò, D., Paganelli, C., Piazzalunga, A., Prati, P., and Valli, G. (2010). Black Carbon and Elemental Carbon measurements in Milan (Po Valley, Italy) by different optical and thermal-optical methods. Abstract 838, *International Aerosol Conference 2010*, Helsinki, 29 August - 03 September 2010.

Vecchi, R., Bernardoni, V., Paganelli, C., & Valli, G. (2014). A filter-based light-absorption measurement with polar photometer: Effects of sampling artefacts from organic carbon. *Journal of Aerosol Science*, 70, 15-25.

Virkkula, A., Ahlquist, N. C., Covert, D. S., Arnott, W. P., Sheridan, P. J., Quinn, P. K., & Coffman, D. J. (2005). Modification, Calibration and a Field Test of an Instrument for Measuring Light Absorption by Particles. *Aerosol Science and Technology*, 39, 68–83.

Wang C., Pana Y.-L., James D., Wetmore A.E., & Redding B. (2014). Direct on-strip analysis of size- and time-resolved aerosol impactor samples using laser induced fluorescence spectra excited at 263 and 351 nm. *Analytica Chimica Acta*, 820, 119-132.

Wei, Y., Ma, L., Cao, T., Zhang, Q., Wu, J., Buseck, P. R., & Thompson, J. E. (2013). Light Scattering and Extinction Measurements Combined with Laser-Induced Incandescence for the Real-Time Determination of Soot Mass Absorption Cross Section. *Analytical Chemistry*, 85, 9181–9188.

Zhou, L., Hopke, P. K., Paatero, P., Ondov, J. M., Pancras, J. P., Pekney, N. J., & Davidson, C. I. (2004). Advanced factor analysis for multiple time resolution aerosol composition data. *Atmospheric Environment*, 38, 4909–4920.

Zotter, P., Herich, H., Gysel, M., El-Haddad, I., Zhang, Y., Močnik, G., Hüglin, C., Baltensperger, U., Szidat, S., & Prévôt, A.S.H. (2016). Evaluation of the absorption Ångström exponents for traffic and wood burning in the Aethalometer based source apportionment using radiocarbon measurements of ambient aerosol. *Atmospheric Chemistry and Physics Discussion*, doi:10.5194/acp-2016-621, 2016

Accepted manuscript

Table 1: limits of detection (LOD) of PP\_UniMI for the analysis of aerosol collected on 47-mm filters. For  $\sigma_{ap}$ , 24h sampling @ 2.3m<sup>3</sup>/h was considered. EBC LOD was obtained from  $\sigma_{ap}$  LOD at 635 nm using MAC=6.6m<sup>2</sup>/g (Petzold et al., 2002)

		405 nm	532 nm	635 nm	780 nm
<b>47-mm filter (PTFE)</b>	LOD ABS	0.07	0.02	0.03	0.03
	LOD $\sigma_{ap}$ (Mm <sup>-1</sup> )	1.5	0.4	0.6	0.6
	LOD EBC ( $\mu\text{g}/\text{m}^3$ )			0.1	

Table 2: limits of detection (LOD) of PP\_UniMI for aerosol collected with high time resolution using the streaker sampler, analysed as-is and using the SFF system. EBC LOD was obtained from  $\sigma_{ap}$  LOD at 635 nm using MAC=6.6m<sup>2</sup>/g (Petzold et al., 2002)

		405 nm	532 nm	635 nm	780 nm
<b>Streaker as-is</b>	LOD ABS	0.15	0.06	0.09	0.08
	LOD $\sigma_{ap}$ (Mm <sup>-1</sup> )	25.0	10.0	15.0	13.3
	LOD EBC ( $\mu\text{g}/\text{m}^3$ )			2.3	
<b>Streaker SFF system</b>	LOD ABS	0.07	0.03	0.04	0.04
	LOD $\sigma_{ap}$ (Mm <sup>-1</sup> )	11.7	5.0	6.7	6.7
	LOD EBC ( $\mu\text{g}/\text{m}^3$ )			1.0	

**Figure captions**

**Figure 1:** Scheme of PP\_UniMI. The scattering plane in which photodiode acquisition occurs is the horizontal plane.

**Figure 2:** Scheme of the optical elements used for beam collimation in streaker configuration. They are added to the elements shown in fig.1 between each laser source and the mirror.

**Figure 3:** Conceptual scheme of the amplification of absorption by aerosol sample leaning a glass fibre filter against the polycarbonate filter (polycarbonate SFF system)

**Figure 4:** a) Example of angular distribution of light intensity on the scattering plane for PTFE filters as-is and leaned against a fibre filter (SFF system) taken at 635 nm; b) scatterplot of aerosol absorption optical depth measured on PTFE filters as-is and on PTFE SFF system at the four wavelengths. Due to the similarity in statistical parameters for different wavelengths, Deming regression using a variation ratio of 1 was performed on the whole dataset.

**Figure 5:** a) Example of angular distribution of light intensity on the scattering plane for thin polycarbonate filters as is and leaned against a fibre filter taken at 635 nm; b) scatterplot of aerosol absorption optical depth (100xABS units are represented) measured on polycarbonate filters as-is and on the polycarbonate SFF system at the four wavelengths.

**Figure 6:** a) Scatterplot of MAAP measurements vs. streaker measurements (635 nm) obtained on the polycarbonate filter leaned against the fibre filter, b)  $\sigma_{ap}$  temporal trends measured by the MAAP and on the streaker sample using the SFF system at 635nm.

**Figure 7:** temporal trends of  $4-\lambda \sigma_{ap}$  measured on the streaker sample using the SFF system (lines) and Ångström Absorption Exponent (histogram)

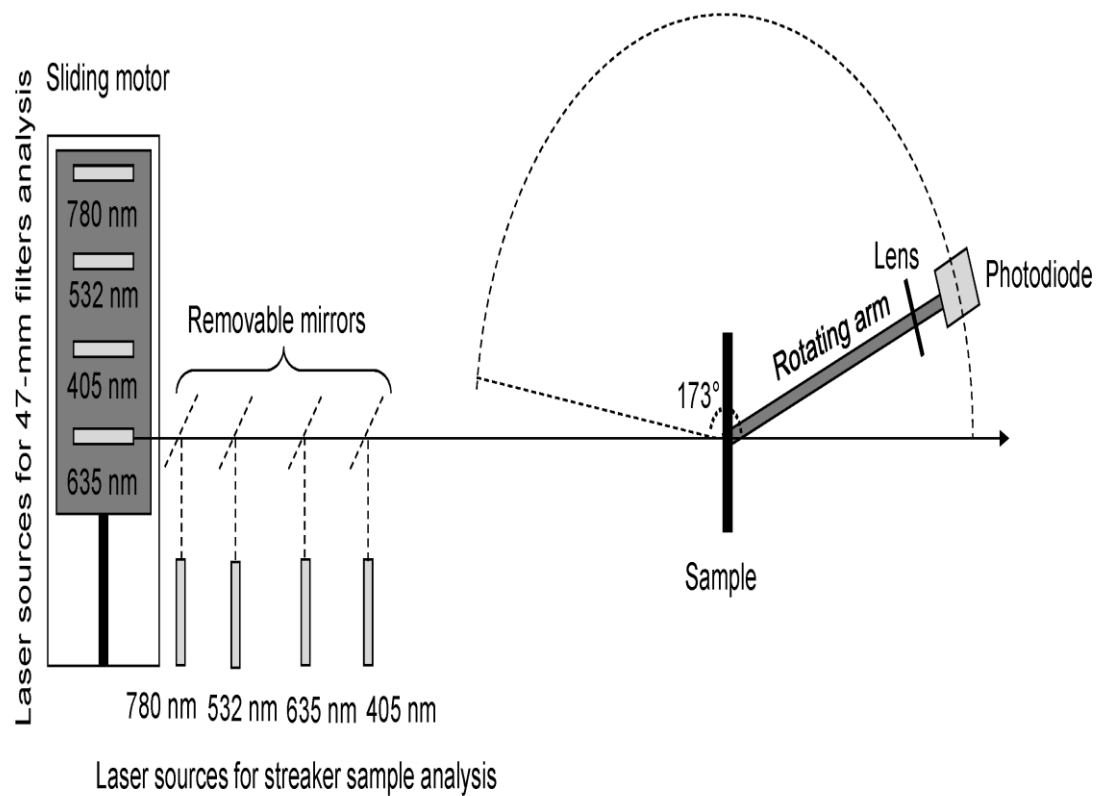



FIGURE 2

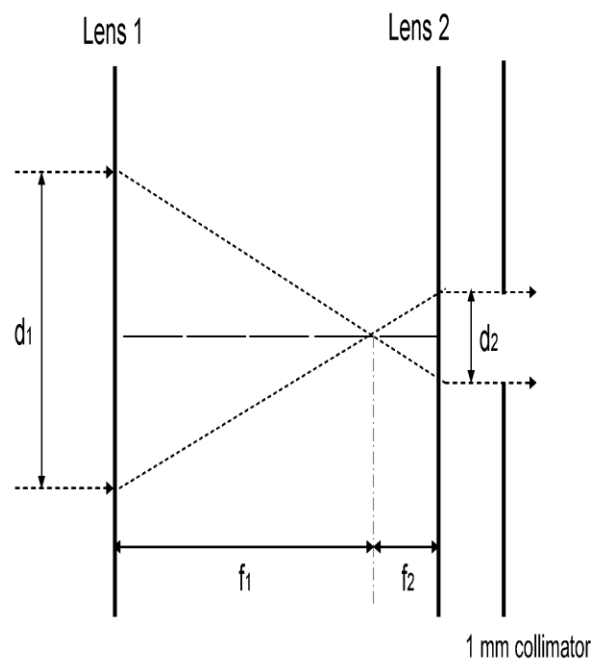

FIGURE 3

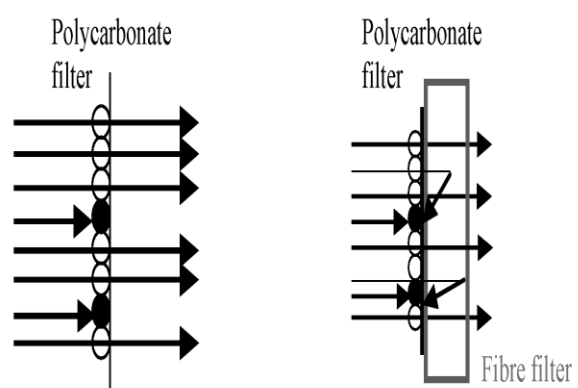

FIGURE 4

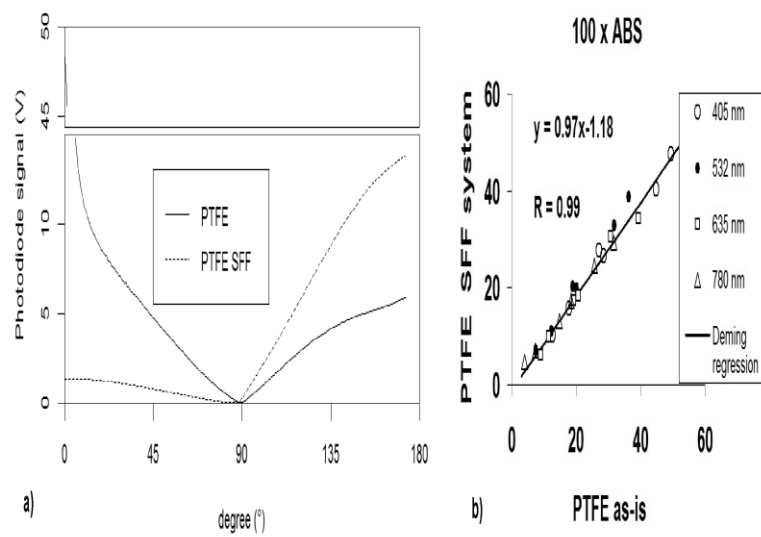
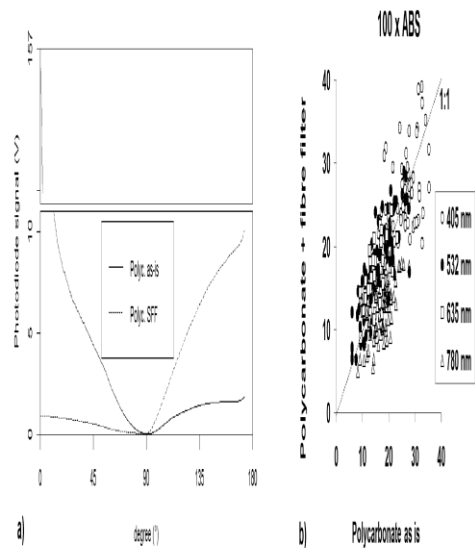

FIGURE 3



d manuscript

FIGURE 6

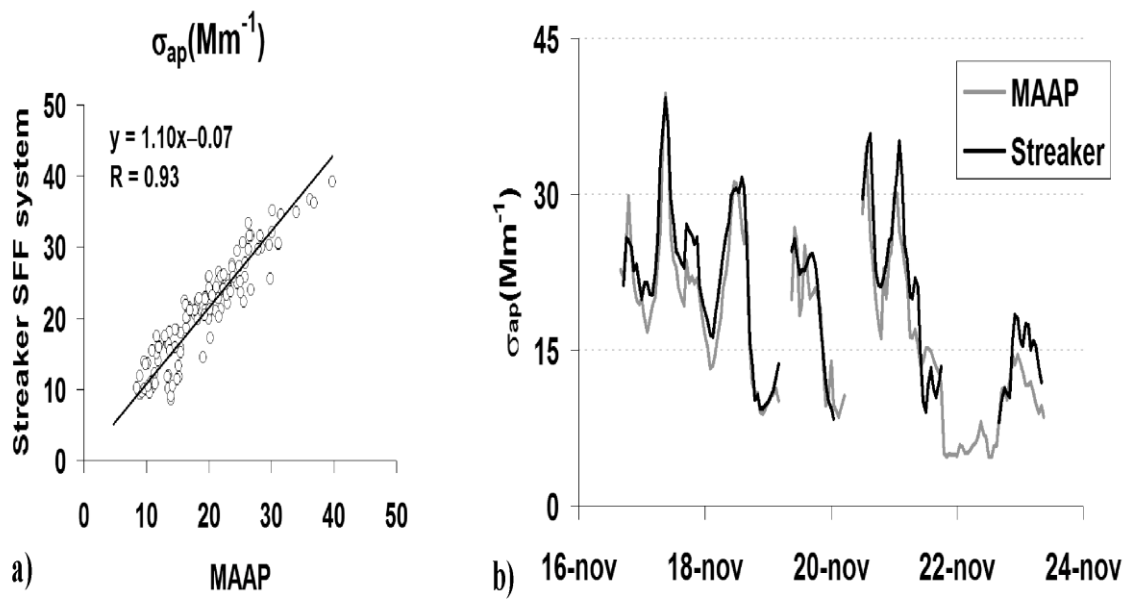
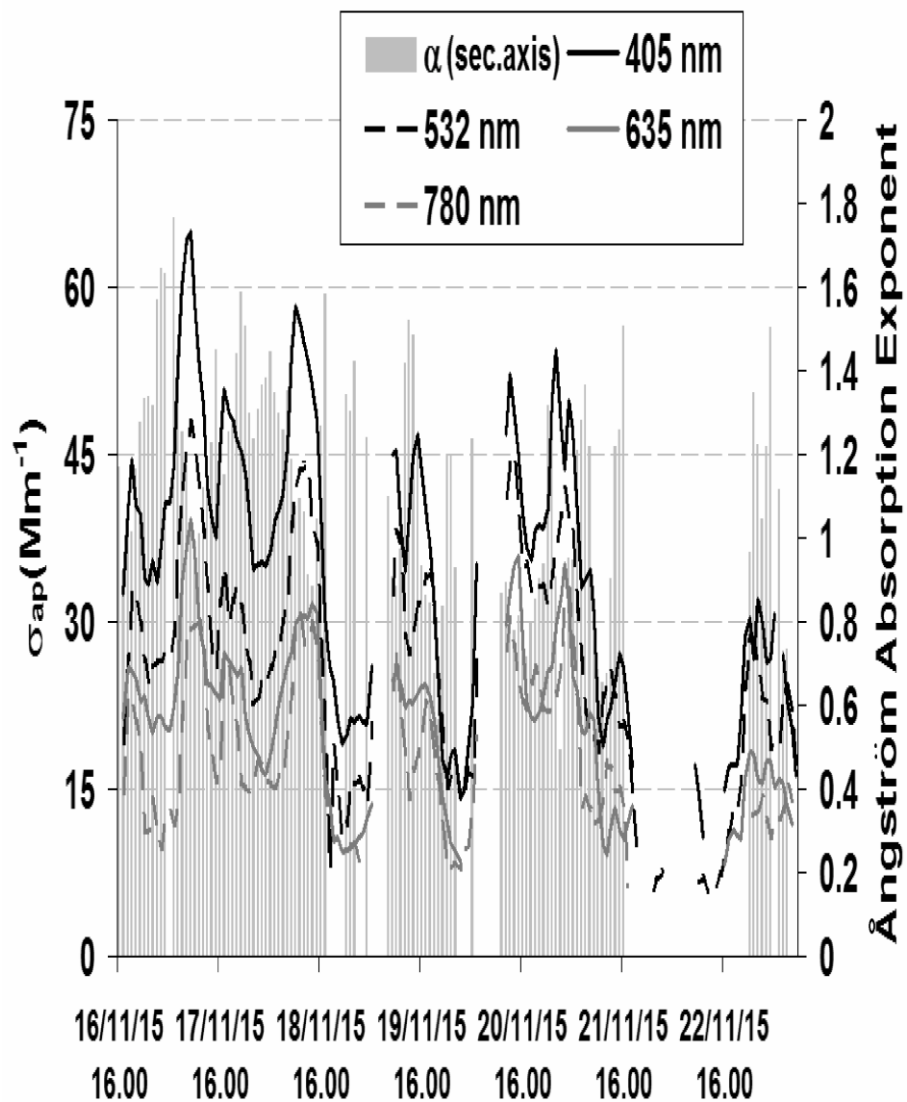

FIGURE 7



### Highlights

- Set-up of a polar photometer to analyse high time resolved samples
- 4- $\lambda$  optical absorption coefficient measurement on filter-sampled aerosol

- Innovative methodology exploiting sample-substrate multiple scattering
- Provides data for source apportionment applications

Accepted manuscript