



UNIVERSITÀ DEGLI STUDI DI MILANO
DIPARTIMENTO DI FISICA

AN INTRODUCTION TO RS485

Abstract: RS 485 specification has been discussed in the present Technical Reports.

TABLE OF CONTENTS

INTRODUCTION	2
LINE LENGTH	5
GROUNDING THE SYSTEM	6
TERMINATIONS	8
TRANSIENT OVERVOLTAGE PROTECTION	16
CIRCUIT BOARD LAYOUT AND PROTECTION DEVICE PLACEMENT	19



INTRODUCTION

Industrial and instrumentation applications require transmission of data between multiple systems often over very long distances. However, in many specific applications the maximum requested distance is of about few meters even if in more recent application a shorter distance can be used. The RS-485 bus standard is one of the most widely used physical layer bus designs in the aforementioned applications. The key features of RS-485 (based on the Standard ANSI TIA/EIA-485-A) that make it ideal for use in these communications applications are:

- Long distance links—up to 1200 m.
- Bidirectional communications possible over a single pair of twisted cables.
- Differential transmission increases noise immunity and decreases noise emissions.
- Multiple drivers and receivers can be connected on the same bus.
- Wide common-mode range allows for differences in ground potential between the driver and receiver.
- TIA/EIA-485-A allow for data rates of up to 10 Mbps. Devices meeting the TIA/EIA-485-A specifications do not have to operate over the entire range and are not limited to 10 Mbps.

This type of bus is mainly used in the following applications: process control networks, industrial automation, remote terminals, building automation, such as heating, ventilation, air conditioning (HVAC), security systems, motor control and motion control.

The main reason why RS-485 can communicate over long distances is the use of differential or balanced lines. A communication channel requires a dedicated pair of signal lines to exchange information. The voltage on one line equals the inverse of the voltage on the other line. Standard ANSI TIA/EIA-485-A designates the two lines in this differential pair as A and B. Line A is more positive than Line B ($V_{OA} > V_{OB}$) on the driver output if a logic high is received on the input of the transmitter ($DI = 1$). If a logic low is received on the input of the transmitter ($DI = 0$), the transmitter causes Line B to be more positive than Line A ($V_{OB} > V_{OA}$).

The typical value obtained for RS485 are here reported:



TABLE 1 – LOGIC VALUE AND MEASURED VOLTAGE IN RS485 ($R_T=120 \Omega$, $R_A=R_B=750 \Omega$, A CONNECTED TO GND AND B CONNECTED TO Vcc).

Function	Logic value	Signal	Measured Voltage	ΔV
Transmission mode	1	DE = 1	VA = 4.3 V	2 V
		TX = 1	VB = 1.3 V	
	0	DE = 1	VA = 1.2 V	- 3.2 V
		TX = 0	VB = 4.4 V	
Receiving mode	N.A.	DE = 0	VA = 2.4 V	- 0.4 V
			VB = 2.8 V	

A differential signaling interface circuit consists of a driver with differential outputs and a receiver with differential inputs. This circuit has increased noise performance because the noise coupling into the system is equal on both signals. One signal emits the opposite of the other signal and electromagnetic fields cancel each other. This reduces the electromagnetic interference (EMI) of the system.

The driver generates, as shown in Figure 1, complementary voltages on A and B lines. Figure 1 shows how EIA-485-A defines V_{OA} , V_{OB} , and V_O . When V_{OA} is low, V_{OB} is high and obviously when V_{OA} is high, V_{OB} is low. Most physical parts (*i.e.* integrated circuit) also have the ability to tri-state both A and B. It is important to note that signals A and B are complementary, but this does not imply that one signal is a current return for the other in fact RS- 485 is not a current loop.

The drivers and receivers must share a common ground as depicted in figure. Receivers are designed to respond to the difference between A and B. V_O is the differential voltage. Receivers must be sensitive to a 200-mV difference between V_{OA} and V_{OB} . Anything less than 200 mV is indeterminate.

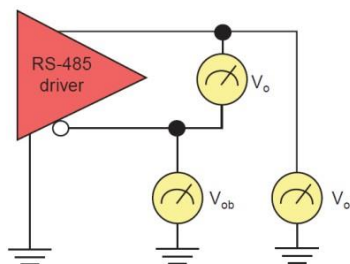

FIGURE 1 - DRIVER OPERATION.



RS 485 SIGNALS

In the following Figure is reported the top view pin-out of the integrated circuit (ISL41847 from INTERSIL) used for RS485.

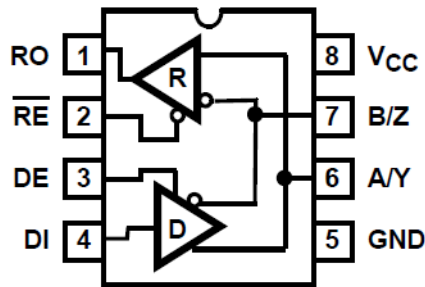

FIGURE 2 – TOP VIEW PIN-OUT OF THE ISL81487.

An RS-485 system must have a driver that can be disconnected from the transmission line when a particular node is not transmitting. The DE (RTS) pin on the RS-485 transceiver enables the driver when a logic high is set to DE (DE = 1). Setting the DE pin to low (DE = 0) puts the driver in a tri-state condition. This effectively disconnects the driver from the bus and allows other nodes to transmit over the same twisted pair cable.

The RS-485 used transceivers have also an RE pin that enables/disables the receiver. The DE and RE pins combined allow some RS-485 transceivers to be put into a low power shutdown mode. This is important for battery-powered applications. The following tables give the thru table for the used device [1].

TRANSMITTING				
INPUTS			OUTPUTS	
RE	DE	DI	Z	Y
X	1	1	0	1
X	1	0	1	0
0	0	X	High-Z	High-Z
1	0	X	High-Z*	High-Z*

*Shutdown Mode for ISL8487, ISL81483 (see Note 7)

RECEIVING			
INPUTS			OUTPUT
RE	DE	A-B	RO
0	0	$\geq +0.2V$	1
0	0	$\leq -0.2V$	0
0	0	Inputs Open	1
1	0	X	High-Z*
1	1	X	High-Z

FIGURE 3 – TRUTH TABLE FOR ISL81487 [1].

The minimum operating circuit is reported in figure.

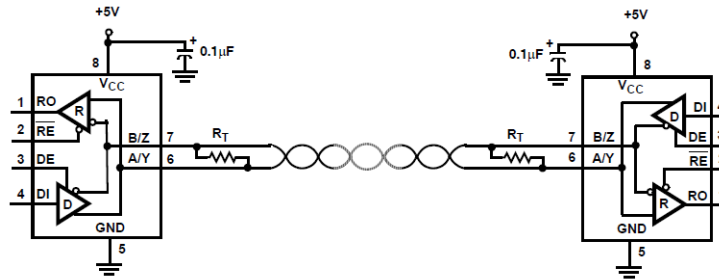

FIGURE 4 – TYPICAL OPERATING CIRCUIT [1].

In case of multi-point half-duplex RS485 link the following configuration is used.

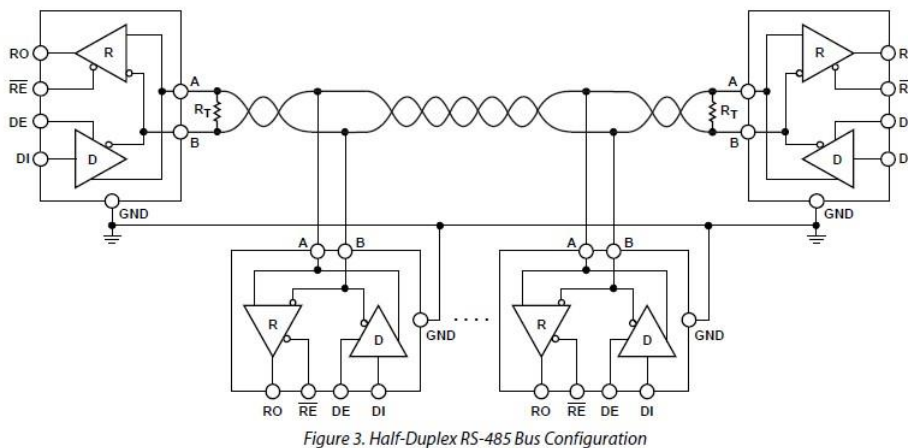

Figure 3. Half-Duplex RS-485 Bus Configuration

FIGURE 5 – TYPICAL OPERATING CIRCUIT FOR HALF-DUPLEX RS-485 BUS CONFIGURATION [2].

This configuration is also known as a 2-wire RS-485 network connected in a multipoint configuration and allows for data transmission in both directions, but only in one direction at a time.

LINE LENGTH

When high data rates are used, the application is limited to a shorter cable. It is possible to use longer cables when low data rates are used. The dc resistance of the cable limits the length of the cable for low data rate applications by increasing the noise margin as the voltage drop in the cable increases. The ac effects of the cable limit the quality of the signal and limit the cable length to short distances when high data rates are used.

More in details the following aspects need to be considered.



The two slopes result from different limitations. The maximum cable length is the result of the voltage divider that the cable's DC loop resistance and the termination resistance create. For differential buses, the loop resistance is twice as high as you might expect, because both conductors in the pair equally contribute.

The curve's sloped portion results from AC limitations of the drivers and the cable.

The following Figure can be used as a **conservative** guide for cable length vs. data rate [2].

Please note that in many cases the application operate at data rate less than 90 kbps. In particular, often the 9600 bps rate (in the past also the rate 4800 bps have been used) and 19200 bps are used.

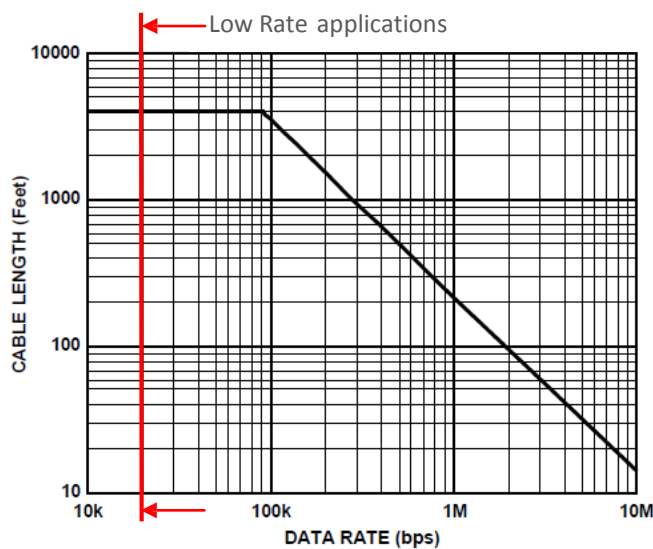

FIGURE 6 - CABLE LENGTH VS. DATA RATE

GROUNDING THE SYSTEM

In order to better understand how to ground the system it is necessary first to define the common mode voltage (V_{cm}). Figure 7 shows how V_{cm} is defined. TIA/EIA-485-A states, "Common-mode voltage (V_{cm}) is the sum of ground potential difference, generator (driver) offset voltage and longitudinally coupled noise voltage."

V_{noise} is coupled identically onto both wires. The result is usually referred to as common-mode noise. If a twisted pair is used, a useful simplification is to model V_{noise} as common mode.

V_{GPD} is the parameter that seems to cause the most problems. The problem stems from the oversimplification that ground is a perfect conductor with null resistance, which is far from the truth.

In fact, earth ground potentials from circuit to circuit in an industrial installation can vary several

volts under normal conditions.

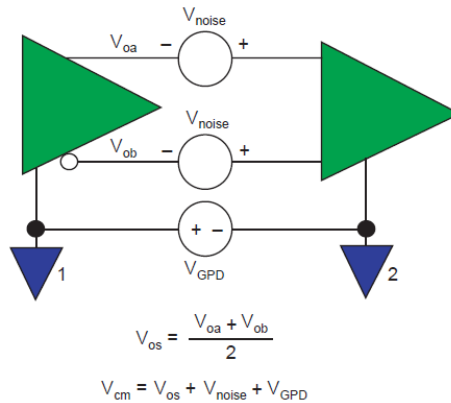

FIGURE 7 - COMMON-MODE VOLTAGE AT THE RECEIVER.

These voltage most often stem from current leaking from equipment into the ground system. However, during electrical activity, potentials between grounds in different parts of a building or system can momentarily, for example, reach tens or hundreds of volts. Potentials between grounds in different buildings or in different locations of the system can even reach thousands or hundreds of thousands of volts. The practical ramification of this is that earth ground is a poor choice for referencing signal grounds on distributed network nodes. The best method for controlling V_{GPD} is to simply run a third wire for the purpose of referencing local signal grounds. The following figure shows a solution often adopted.

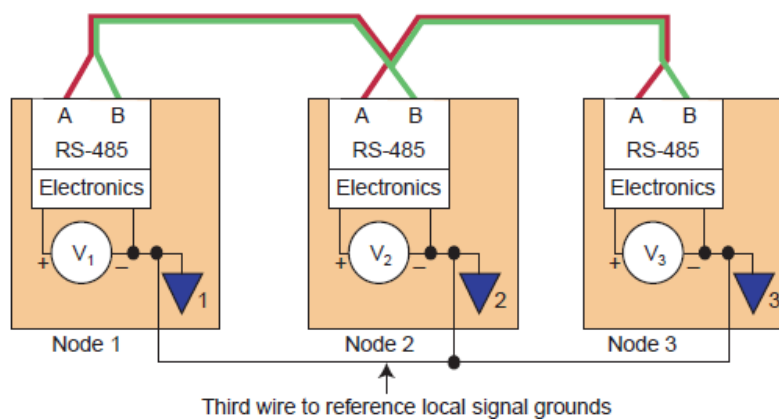

FIGURE 8 - GROUNDING THE SYSTEM.

The common-mode voltage (V_{cm}) allowable between drivers and receivers on an RS-485 network is +12 to -7 V. This setup provides 7 V of protection from each rail (assuming systems supplied at 5V). When the common-mode voltage on a node drifts beyond the allowable V_{cm} of +12 to -7 V,



the node is no longer guaranteed to function. In fact, the drivers and receivers in the node may be subject to damage.

The adopted solution for RS485 bus make available the following wires:

- Line A, signal
- Line B, signal
- GND, ground (for grounding the system)
- Vcc = 5 V (reserved).

TERMINATIONS

In a transmission line, there are two wires, one to carry the currents from the driver to the receiver and another to provide the return path back to the driver. RS-485 links are a little more complicated because of the fact that they have two signal wires that share a termination as well as a ground return path.

For reliable RS-485 communications, it is essential that the reflections in the transmission line be kept as small as possible and this is possible only if a proper cable termination is present.

Reflections happen very quickly during and just after signal transitions. On a long line, the reflections are more likely to continue long enough to cause the receiver to misread logic levels. On short lines, the reflections occur much sooner and have no effect on the received logic levels.

Terminating a data cable with a resistor having value equal to the cable characteristic impedance reduces reflections that could cause data errors. However, if the data rate is low and/or the cable is particularly short termination may be not necessary. As data rates increase termination becomes important and often mandatory. Generally speaking, since any device on the bus can transmit, it is probable that a node within the middle of the bus will transmit requiring that termination be applied to both ends of the bus segments. In fact, RS-485 applications require termination at the master node and the slave node furthest from the master. Several options are available for terminating an RS485 bus. The following Table shows a comparison of different termination techniques.



TABLE 2 - TERMINATION ADVANTAGES AND DISADVANTAGES [2].

Termination	Advantages	Disadvantages
None	Simple, low power	Suitable only for short links with slow drivers
Parallel	Simple	High power
AC	Low power	Suitable only for low bit rates and short links

- a) **WITHOUT TERMINATION:** The time required for a signal to propagate down the line to a receiver determines if a line is considered a transmission line. Physically long wires have longer propagation times, whereas physically short wires have shorter propagation times. When the propagation time is short relative to the data bit duration, the effect on the signal quality is minimized. A cable is not seen as a transmission line if the signal rise time is more than four times the propagation delay of the cable.
- b) **PARALLEL TERMINATION:** When two or more drivers share a pair of wires, each end of the link has a termination resistor equal to the characteristic impedance of the cable. There should be no more than two terminating resistors in the network regardless of how many nodes are connected (see Figure 9 where only the case of a differential driver sending information to a differential receiver is reported. The case of bidirectional line is discussed in the following). In a half-duplex configuration, both ends of the cable must be terminated. In a full duplex configuration only the master receiver and most remote slave receiver need to be terminated, as shown in Figure 5. This is the most popular solution for termination and it is known also as DC termination. Resistive termination have typically values of 120Ω although twisted-pair cable impedances can be as low as 100Ω . Please note that the 100Ω value is too small for EIA-485 drivers.

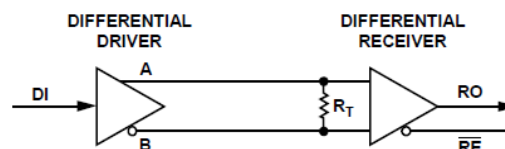

FIGURE 9 - PARALLEL OR DC TERMINATION.

- c) **AC TERMINATION:** AC termination is used to reduce the power consumption of idle links as well as to reduce ringing voltages. The negative effect though is a reduction in cable length and bit rate. A resistor and capacitor can be placed in series across the bus (between A and B) as shown in Figure 5. The Capacitor C_T is selected in function of both the delay introduced by the cable and the characteristic impedance of the cable, *i.e.* it is not possible to calculate a capacitance value valid for all the applications.

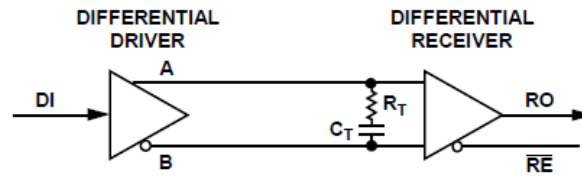

FIGURE 10 - AC TERMINATION.

Another popular option is a modified parallel termination that also provides a fail-safe bias. A detailed discussion of fail-safe biasing occurs later in the next Section and will be not further discussed in this Section. Figure 11 compares the four popular termination methods. The main point to remember is that, if you use termination, you should locate the termination networks at the two extreme ends of the cable, not at every node [3].

SYMBOL				
TERMINATION NAME:	UNTERMINATED	PARALLEL	RC TERMINATION	FAILSAFE
DATA RATE:	LOW	HIGH	MEDIUM	HIGH
SIGNAL QUALITY:	LIMITED	EXCELLENT	LIMITED	EXCELLENT
POWER:	LOW	HIGH	LOW	HIGH

FIGURE 11 - RS-485 BUSES CAN USE FOUR METHODS OF TERMINATION. ACHIEVING THE BEST ELECTRICAL PERFORMANCE REQUIRES ACCEPTING HIGHER POWER DISSIPATION IN THE TERMINATION RESISTORS [3].

It is possible to evaluate the situation from a quantitative point of view.

There are several rules of thumb to follow when predicting if the line is long enough to be a transmission line.

The first very good rule of thumb consider that if the propagation delay of the data is much less than one bit width termination is mandatory. This rule make the assumption that reflections will damp out in several trips up and down the data line. Since the receiving UART will sample the data in the middle of the bit, it is important that the signal level be solid at that point. For example, in a system with 600 m of data line the propagation delay can be evaluated by multiplying the cable length by the propagation velocity of the cable. This value, typically 66 to 77 % of the light speed, is specified by the cable manufacturer. For example, a round trip cover 1200 m of cable. Using a propagation velocity of $66\% \times c$, one round trip is completed in approximately $6.2 \mu\text{s}$. If we assume the reflection will damp out in three "round trips" up and down the cable length, the signal will stabilize in $18.6 \mu\text{s}$ after the leading edge of a bit. At 9600 baud one bit is $104 \mu\text{s}$ wide. Since the

reflections are damped out much before the center of the bit, termination is not mandatory. However, the termination can be used in order to meet the requirement also in different situation in particular when noise is present (as often in industrial applications).

In the following figure two different waveform are shown: at the left the signal without termination is depicted whereas at the right the same signal with termination.

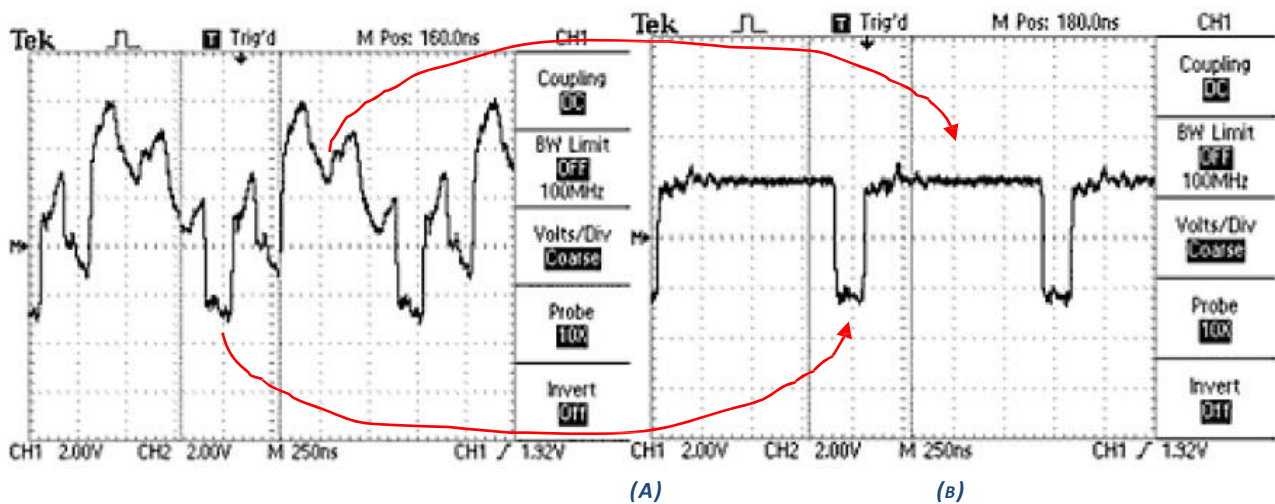

FIGURE 12 - AN UNTERMINATED RS-485 WAVEFORM (A), COMPARED WITH A WAVEFORM OBTAINED FROM A CORRECTLY TERMINATED NETWORK (B).

FAIL-SAFE BIASING

In Figure 13 a configuration of a master/slave RS-485 network with no fail-safe biasing is shown. A synchronous data transmission is typically used in many industrial applications. A start bit indicates the start of a bit sequence and is detected when a transition occurs from high to low. Eight data bits and a parity bit follow the start bit. A stop bit that can be one or two bits long follows this bit sequence. A following start bit starts the next bit sequence. When the last character is sent the line should stay high until the next start bit. This causes problems in multipoint applications when the transceivers connected on the bus are in receive mode simultaneously. This is known as a bus idle condition and in this case, the differential voltage on the bus ($V_{OA} - V_{OB}$) is 0 V. Under this condition, the receiver output (RO) is undefined by the RS-485 standard and, thus, the receiver output can produce random data. This data is connected to the UART and can cause erroneous system operation.

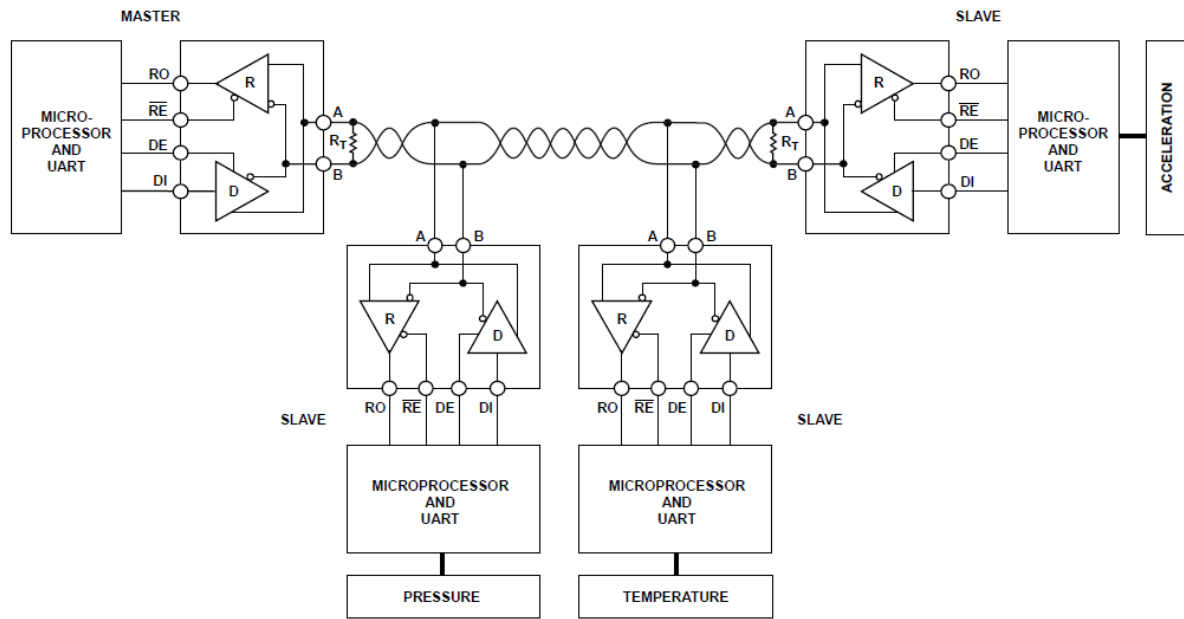

FIGURE 13 - MASTER/SLAVE RS-485 NETWORK WITH NO FAIL-SAFE BIASING OF THE NETWORK.

The differential input threshold voltage (V_{TH}) of a receiver is the voltage on the receiver input at which a transition (low to high or high to low) of the receiver output is guaranteed. A typical RS-485 transceiver has a differential input threshold voltage of ± 200 mV. What this means is that when the differential input is larger than or equal to 200 mV ($V_{IA} - V_{IB} \geq 200$ mV), the receiver output is guaranteed to be high ($RO = 1$). When the differential input is less than or equal to -200 mV ($V_{IA} - V_{IB} < -200$ mV), the receiver output is guaranteed to be low ($RO = 0$). See Table 3 for a truth table for the receiver.

TABLE 3 - DIFFERENTIAL RECEIVER TRUTH TABLE.

\overline{RE}	A - B (Inputs)	RO
0	$\geq +200$ mV	1
0	≤ -200 mV	0
0	-200 mV \leq (A - B) \leq +200 mV	X
1	X	High-Z

In FIGURE 14 report the value for unbalanced lines A and B. typical values are 3.68 V for high level and 1.48 V for low level ($R_T=120 \Omega$, $R_A=R_B=560 \Omega$, A connected to V_{CC} and B connected to GND). In this way $V_{AB} = 2.2$ V when $V_A > V_B$ and $V_{AB} = -2.2$ V when $V_A < V_B$.

In Figure 15 waveform for balanced line at the driver and at the receiver are shown. Typical values for applications are:

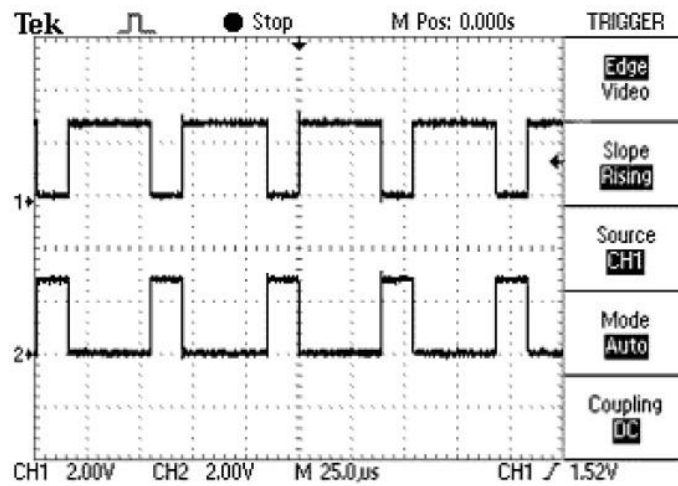
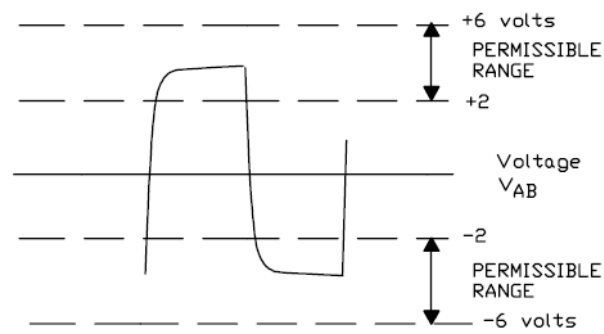
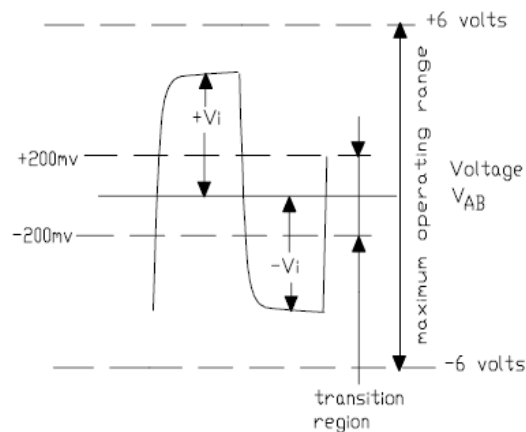

FIGURE 14 – WAVEFORM FOR UNBALANCED LINES A AND B (REFERRED TO GND) [5].



(A)



(B)

FIGURE 15 – WAVEFORM FOR DRIVER (A) AND RECEIVER (B) [6].

During the bus idle condition, there is no device driving the bus. The receiver output is undefined. This can cause random data to be received on the UART, which in turn can cause false start bits,

false interrupts, and framing errors. This problem can be solved by placing a combination of pull-up and pull-down resistors at one position on the bus. Figure 9 shows the biasing resistor circuit. An example of calculating R_1 and R_2 is shown below (assume $R_T = 120 \Omega$):

$$R_1 = R_2 = R$$

$$V_{IA} - V_{IB} \geq 200 \text{ mV}$$

$$V_{IA} - V_{IB} = R_T \times V_{CC} / (2R + R_T) = 200 \text{ mV}$$

$$\text{if } V_{CC} = 5 \text{ V, then } R = 1440 \Omega$$

$$\text{if } V_{CC} = 3 \text{ V, then } R = 960 \Omega$$

If lower values for R are used ($V_{IA} - V_{IB} > 200 \text{ mV}$), a greater noise margin can be achieved in the system. See Figure 16 for a graphical representation of the bus states and differential input voltage.

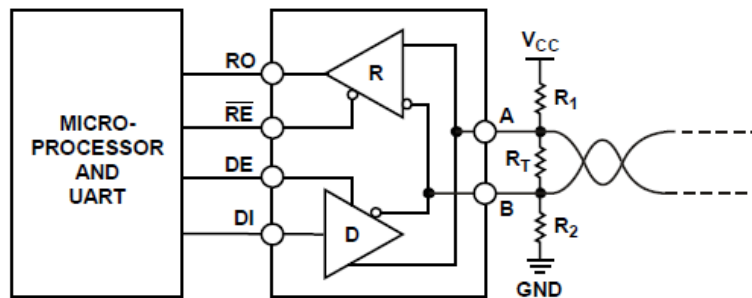

FIGURE 16 - FAIL-SAFE BIASING CIRCUIT.

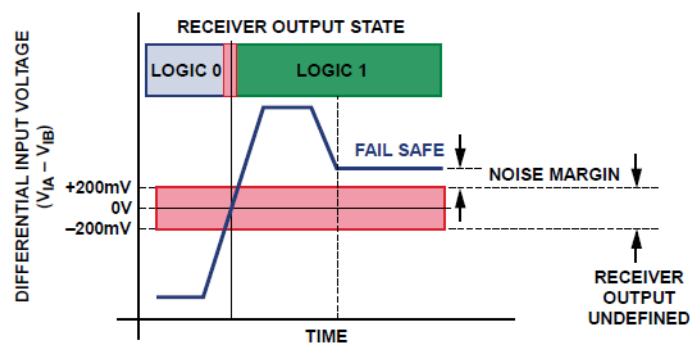

FIGURE 17 - DIFFERENTIAL INPUT VOLTAGE.

It is important to highlight that new generation RS-485 transceivers have an improved feature that includes true fail-safe receiver inputs. This eliminates the need for pull-up/pull-down resistors as shown in the previous example. If a transceiver is specified to have a true fail-safe feature this means that, the differential input threshold voltage (V_{TH}) has been adjusted from $\pm 200 \text{ mV}$ to -200 mV to -30 mV (as shown in Figure 18). During the bus idle condition, $V_{IA} - V_{IB} = 0$ and therefore is

larger than -30 mV, resulting in the receiver output being high ($RO = 1$). This means that if all transceivers connected to the bus have true fail-safe features, the receiver output is always defined. However, it is important to know that it is not always possible to know if all transceivers connected to the bus have true fail-safe features, in particular when devices are connected with devices of other manufacturer.

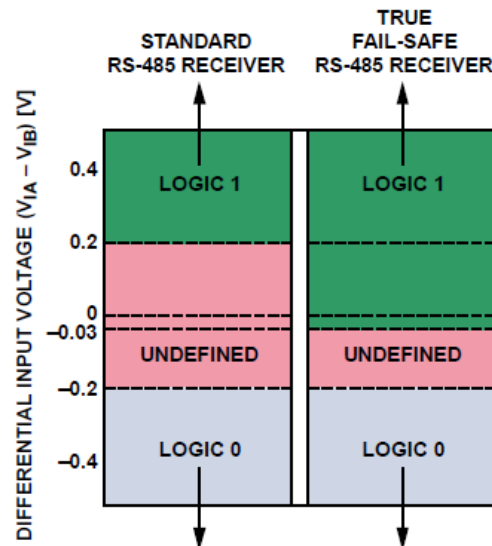

FIGURE 18 - INPUT THRESHOLD VOLTAGE.

TOPOLOGY

Figure 19 shows several network topologies. When the signals on the network are slow, the bit edges are long, and the cable runs are short, topology is not an issue. Considering both the data rate and the line length in bus different topologies can be probably used. However it is better to consider as discussed in the following.

As soon as transmission line effects begin to show up, there is only one simple topology for managing them. This is not to say, for example, that it's impossible to implement a star configuration with RS-485 devices. However, the best and simpler way to ensure a robust and reliable RS-485 network is to build it around a daisy-chain configuration. In fact, only the daisy chain is easy to manage reflections on.

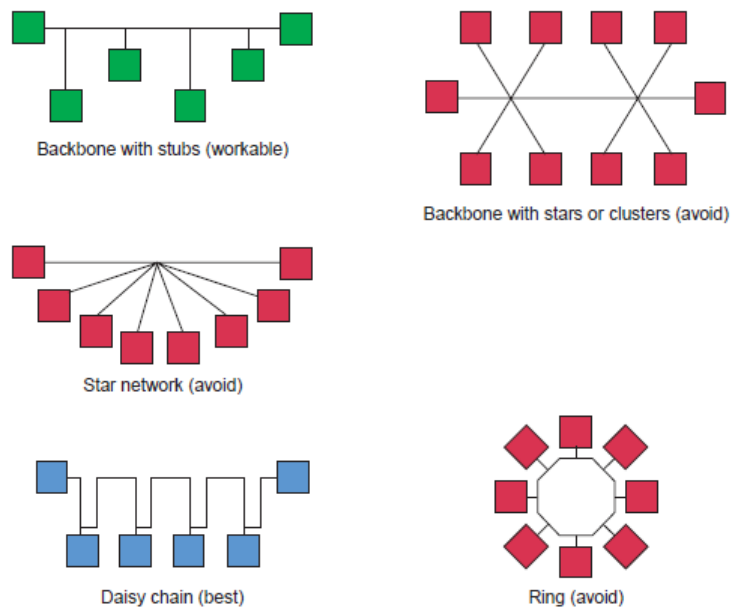

FIGURE 19 - COMMON NETWORK TOPOLOGIES.

TRANSIENT OVERVOLTAGE PROTECTION

In industrial applications, lightning strikes, power source fluctuations, inductive switching, and electrostatic discharge can cause damage to RS-485 transceivers by generating large transient voltages. Starting from these considerations, as with any system design, consideration must be given to the natural and induced environmental conditions to be encountered during operation. Factory-controlled applications generally require protection against excessive noise voltages. The noise immunity afforded by the differential transmission scheme, and, in particular, the wide common-mode voltage range of 485, may be insufficient.

Many manufacturers offer a broad range of RS-485 devices with enhanced ESD protection such as the ISL81487. This device has a “Built-In Driver Overload Protection”, a short circuit current limits, and on-chip thermal shutdown circuitry. In particular, the driver output stages incorporate short circuit current limiting circuitry which ensures that the output current never exceeds the RS-485 spec, even at the common mode voltage range extremes. Additionally, these devices utilize a foldback circuit which reduces the short circuit current, and thus the power dissipation, whenever the contending voltage exceeds either supply.

However, sometimes internal protection are not sufficient.

The level of protection can be, at this aim, further enhanced when using external clamping devices, such as TVS diodes (see the typical circuit in Figure 20 where the voltage and parts are also described).

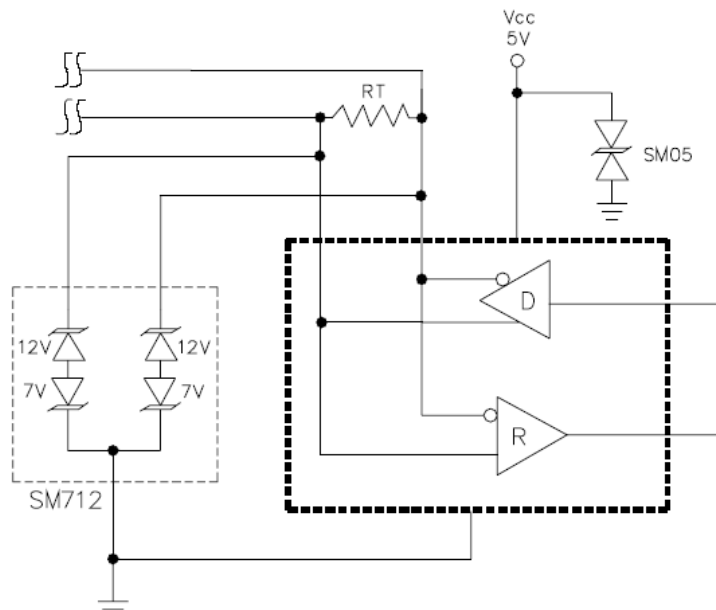

FIGURE 20

The protection is accomplished by clamping the voltage spike to a limit, by the low impedance avalanche breakdown of a PN junction. TVS diodes are ideally open-circuit devices. A TVS diode can be modeled as a large resistance in parallel with some capacitance while working below its breakdown voltage. When a transient is generated and the surge voltage is larger than the breakdown voltage of the TVS, the resistance of the TVS decreases to keep the clamping voltage constant. The TVS clamps the pulse to a level that does not damage the device that it is protecting. The transients are clamped instantaneously (< 1 ns) and the damaging current is diverted away from the protected device. In the Figure 21 characteristic of a unidirectional TVS diode is shown whereas in Figure 22 the characteristic of a bidirectional TVS diode is also reported.

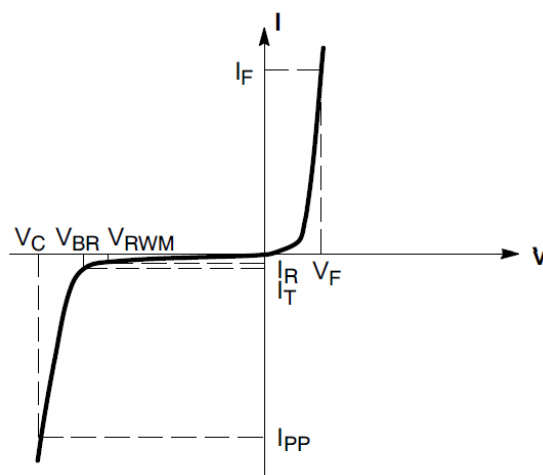

FIGURE 21 – I-V CHARACTERISTIC FOR TVS DIODE.

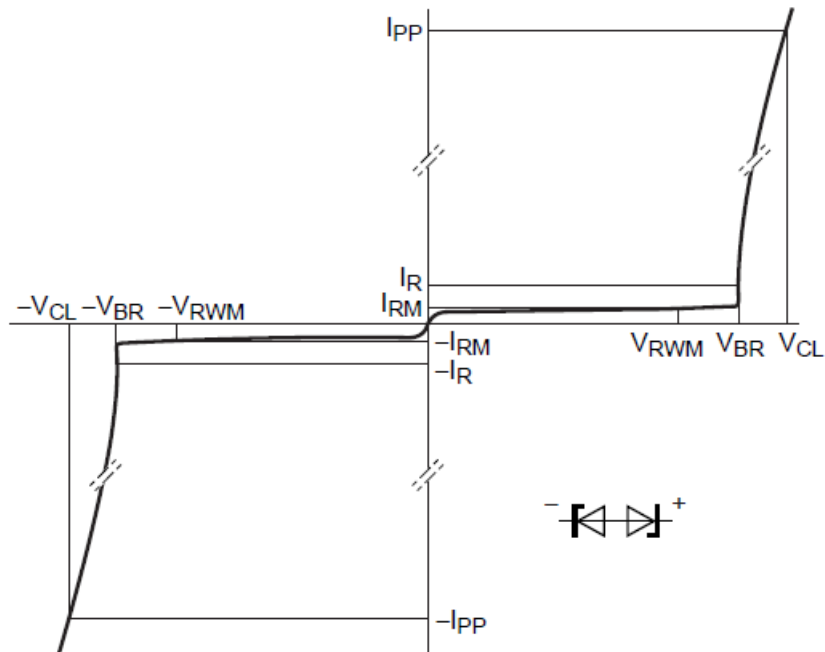

FIGURE 22 - I-V CHARACTERISTIC FOR TVS DIODE.

The function of a TVS in RS-485 applications is to clamp the voltage on the bus to the common-mode voltage range of the RS-485 transceiver (-7 V to $+12\text{ V}$). Some TVS devices have been specifically designed for RS-485 applications. For higher power transients, protection can be increased by adding Resistors R_S (between $10\ \Omega$ and $20\ \Omega$) between the protected device and the input pin as shown in the following figure.

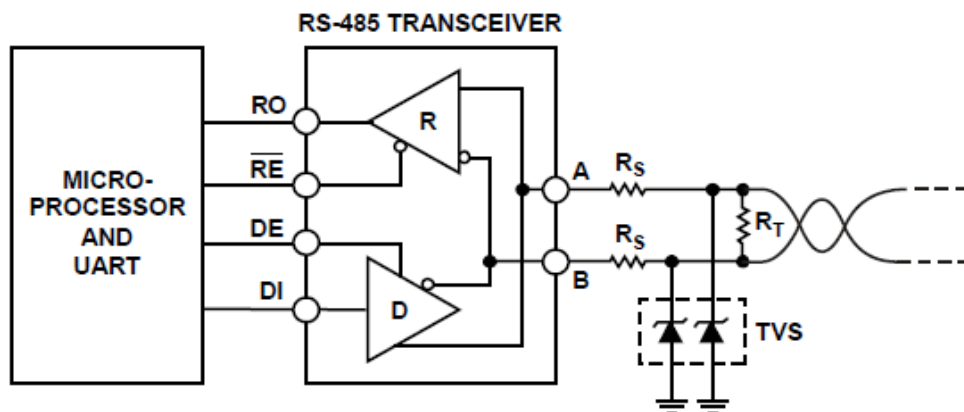

FIGURE 23

The complete solution for overvoltage protection is reported in the following figure.

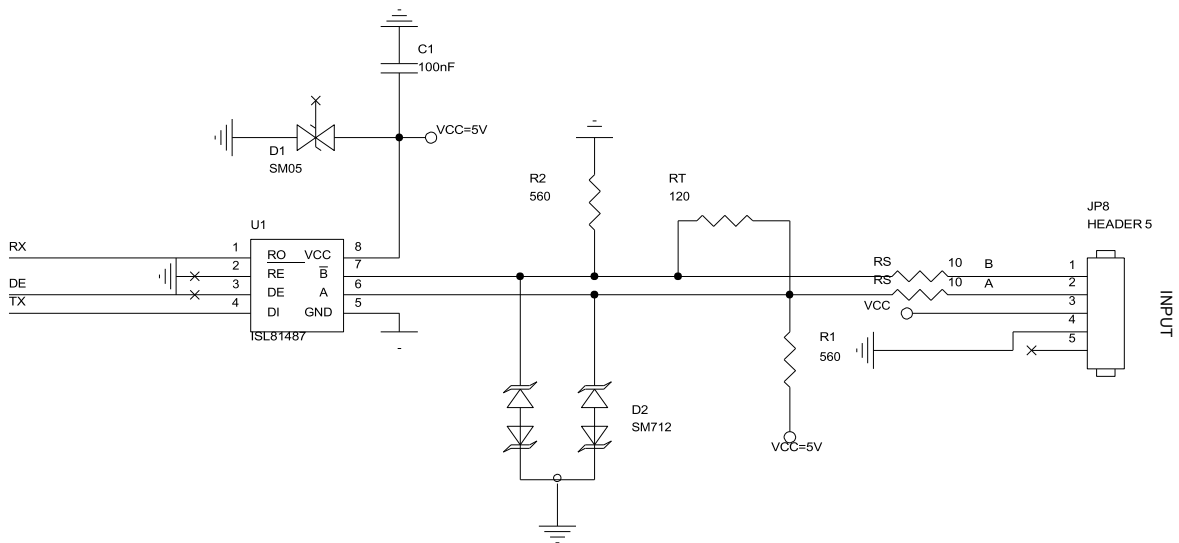

FIGURE 24 - COMPLETE SCHEMATIC CIRCUIT OF RS485 BUS.

In the figure:

- D1 is the TVS diode used for protection of the supply line of the ISL81487;
- D2 are the TVS diodes for protection of the signal lines;
- R1 and R2 are the resistor used for fail-safe operations;
- RT is the termination resistor;
- RS are the current limiting resistor.

Please note that in some application not all devices are presents.

CIRCUIT BOARD LAYOUT AND PROTECTION DEVICE PLACEMENT

Circuit board layout is critical for the suppression of ESD, Electrical Fast Transient (EFT) and surge transients. The following guidelines can be applied (when possible and as possible) in routing the PCB RS485 area:

1. The TVS Diodes are placed as close to the input terminal or connector as possible.
2. The path length between the TVS Diodes and the protected line should be minimized.
3. Parallel signal paths are minimized.
4. Running protected conductors in parallel with unprotected conductors are avoided.
5. All Printed-Circuit Board (PCB) conductive loops including power and ground loops are



minimized.

6. The length of the transient return path to ground are minimized.
7. The use of shared transient return paths to a common ground point are avoided.
8. Ground planes should be used whenever possible. For multilayer PCBs, ground vias are used.



REFERENCES

- [1] ISL81487 Datasheet, July 31, 2006, FN6050.7, Intersil.
- [2] Hein Marais, RS-485/RS-422 Circuit Implementation Guide, AN-960 - APPLICATION NOTE, Rev. 0, 2008 Analog Devices, Inc.
- [3] John Goldie, Ten Ways to Bulletproof RS-485 Interfaces, National Semiconductor, Application Note 1057, October 1996.
- [4] Bob Perrin, The Art and Science of RS-485, FEATURE ARTICLE, CIRCUIT CELLAR® ONLINE, July 1999, www.circuitcellar.com.
- [5] TUTORIAL 763 : Guidelines for Proper Wiring of an RS-485 (TIA/EIA-485-A) Network, Nov 19, 2001, <http://www.maximintegrated.com/an763>, Maxim.
- [6] Application Note. RS-422 and RS-485. Revised october 1997, B & B Electronics Mfg. Co. Inc., Ottawa, IL, 61350, USA, www.bb-elec.com.