



SURF BIOMECHANICS AND BIOENERGETICS

Academic thesis submitted in partial fulfilment of the requirements for obtaining
a doctoral degree in sports sciences according to the Decree-Law nº. 74/2006

March 24th.

Márcio Borgonovo-Santos

Porto, 2018

ACADEMIC THESIS

Not published in its entirety, because it contains confidential information with patent potential.

Submitted in partial fulfilment of the requirements for obtaining a doctoral degree, Faculty of Sport, University of Porto.

Center of Research, Education, Innovation, and Intervention in Sport (CIFI²D)

Faculty of Sports (FADEUP)

Porto Biomechanics Laboratory (LABIOMEUP-UP)

University of Porto (UP)



Copyright © 2018 by Márcio Borgonovo-Santos

All rights reserved. You may copy, distribute, display, and perform the work under the following conditions: Attribution: You must attribute the work in the manner specified by the author or licensor; Non-commercial: You may not use this work for commercial purposes; No Derivative Work: You may not alter, transform, or build upon this work.

Notice: For any reuse or distribution, you must make clear to others the license terms of this work. Any of these conditions can be waived if you get permission from the copyright holder.

The web addresses cited in this text were current as of March 2018, unless otherwise noted.

Cover Designer: Marcio Borgonovo-Santos

Illustration (cover): Phil Roberts Studio (<https://philroberts.com/about/>)

Photographs (interior): © Márcio Borgonovo-Santos, unless otherwise noted.

Illustrations: © Márcio Borgonovo-Santos, unless otherwise noted.

Printer: Reprography of Sports Faculty – University of Porto.

Doctoral Thesis in Sport Sciences.

Porto, 2018

Ph.D. Thesis Supervision

Supervisor

João Paulo Vilas-Boas, Ph.D.

University of Porto, POR

Co-Supervisors

Ricardo Fernandes, Ph.D.

University of Porto, POR

Pedro Figueiredo, Ph.D.

Portuguese Football Federation, POR

Borgonovo-Santos, M. (2018). *Surf Biomechanics and Bioenergetics*. (PhD).
Center of Research, Education, Innovation, and Intervention in Sport, Faculty of
Sport, University of Porto.

Keywords: surf biomechanics, surfboard sensor, surf kinematics, surf paddling,
surf energetic profile.

Dedication

In memory of Professor
Ruy Jornada Krebs

My core family

Gualberto Cesar dos Santos & Anita Borgonovo

Marcelo Borgonovo dos Santos & Simone Borgonovo dos Santos

Statement of Originality

I hereby certify that all of the work described in this thesis is the original work of the author. Any published (or unpublished) ideas, techniques, or both from the work of others are fully acknowledged by the standard referencing practices.

Márcio Borgonovo-Santos

December of 2018

[signature is available in the printed version]

Ethical Disclaimer

Ethical approval for the studies mentioned in this thesis has been granted by the Ethics Committee of Faculty of Sport, University of Porto (Process number: CEFADE 27/2014; Appendix VII).

All subjects who participated in the studies of this thesis were free from any physical impairment and signed a consent form. For children, this consent form was obtained from their parents or legal guardian. All participants were fully informed about the nature and objectives of the studies.

Abstract

Modern surfing has been described as an intermittent physical activity, which varies in duration and intensity, followed by considerable recovery periods. Currently, the analysis and judgment of surf sessions are based on empirical knowledge, experience, and observation. In other words, procedures that involve great measurement errors. However, it is extremely difficult to obtain analytical information on performance parameters. The first scientific investigations in the surf world faced a classic difficulty of the world of science, which is to measure without interfering. In addition, the maritime environment, particularly due to salt water, is extremely hostile to electronic components, which are currently our largest source of quantitative information.

This research aimed to investigate the horizontal phase of surfing, specifically the sprint paddling, endurance paddling and the transition pop-up - standing technique. The whole pack under a biomechanics perspective, associated with bioenergetic parameters. The general approach was supported by process of deconstruction of movements and techniques in didactic parts, in order to reconstruct a global knowledge, and a better understanding of surfing. Looking to the future, we aggregate to this project the development of technological resources that make it possible to explore surf directly in the ocean. All this gained even more relevance since Surf has been selected as the new Olympic sport for the next Games of Tokyo 2020. The Olympic Games are an excellent opportunity where surfing will become more professional and organised. In this context, the metrics for performance evaluation are important to help validating teaching-learning methodologies, support training and competitive judgments.

Keywords: surf biomechanics, surfing, surf paddling, pop-up, take-off, measurements.

Resumo

O surf moderno vem sendo descrito como uma atividade física intermitente, que varia em duração e intensidade, seguida de períodos de recuperação consideráveis. Atualmente, a análise e avaliação das sessões de surf são baseadas em conhecimento empírico, experiência e observação. Em outras palavras, procedimentos que envolvem grandes erros de medição. No entanto, é extremamente difícil obter informações analíticas sobre os parâmetros de desempenho. As primeiras investigações científicas no mundo do surf enfrentam uma dificuldade clássica do mundo da ciência, que é medir sem interferir. Além disso, o ambiente marítimo, particularmente devido à água salgada, é extremamente hostil aos componentes eletrônicos, que atualmente são a nossa maior fonte de informações quantitativas.

O objetivo desta pesquisa foi investigar a fase horizontal do surf, especificamente a remada de potência, a remada de longa duração e a técnica de transição para ficar de pé na prancha de surf. Todo este pacote sob a perspectiva da biomecânica, associado a alguns parâmetros bioenergéticos. A abordagem geral foi apoiada por um processo de desconstrução dos movimentos e técnicas em partes didáticas, a fim de reconstruir um conhecimento global e uma melhor compreensão do surf. Olhando para o futuro, agregamos a este projeto o desenvolvimento de recursos tecnológicos que possibilitam explorar o surf diretamente no oceano. Tudo isso ganha ainda muito mais peso, desde que o Surf foi selecionado como novo esporte olímpico para os Jogos de Tóquio, em 2020. Os Jogos Olímpicos passam a ser uma excelente oportunidade, onde o surf se tornará mais profissionalizado e organizado. Neste contexto, as métricas para avaliação de desempenho são importantes para ajudar a validação de metodologias de ensino-aprendizagem, treinamento e julgamentos competitivos.

Palavras-chave: biomecânica do surf, surfing, remadas do surf, ficar de pé, medições.

Financial Support

This entire project was partially supported by:

- **CAPES** - Coordination for the Improvement of Higher Education Personnel – PhD scholarship BEX 0819140 (2014-2016).
- **ESA BIC PT, IPN** – European Space Agency – Business Incubator Center Portugal – by Instituto Pedro Nunes. Scholarship Young Entrepreneur in the Space (2017).

Acknowledgements

I would like to denote the deepest gratitude and posthumous homage to my friend, tutor and academic father Professor Ruy Jornada Krebs (1948-2010[†]).

I would first, and foremost, like to express the deepest gratitude to Professor João Paulo Vilas-Boas for his constant belief and support throughout my PhD journey. He encouraged me to think creatively about my project and to incorporate many research interests and ideas. He provided the resources required to conduct this study and the feedback to write the manuscript. Thanks for helping me pursue the process to reach the polished stone.

To the friends that joined me in this doctoral trip.

To the entities that believed and supported this project: LABIOMEUP-UP Staff (Pedro Fonseca, Sara Tribuzi, Denise Soares and Pooya Soltani); Surf Clube Viana - Surf High Performance Centre Viana do Castelo (João Zamith and Tiago Prieto); Santa Catarina State University – Brazil (Prof. Hélio Roesler; Prof, Susana Pereira; Caroline Ruschel; Marcel Hubert and the entire laboratory team); UPTEC Incubator (Susana Pinheiro) and University of Porto Innovation – UPIN (Prof. Carlos Brito); Carnegie Mellon Portugal (Prof. João Claro) – Entrepreneur Internship USA during 3 months; Center for Surf Research - California (Jess Ponting); University of San Marcos – California (Jeff Nessler and Sean Newcomer); Pedro Nunes Institute and European Space Agency - ESA (Francisca Eiriz) – Scholarship Young Entrepreneur In Space; Lead Sports Accelerator Program – ADIDAS Family Office Berlin (Tim Krieglstein); Riedel Communications (Thomas Riedel and Jürgen Eckstein); Bio Boards (Ricardo Marques); AllinSurf (José Costa and Miguel Albuquerque); mOceanSense (Daniela Lopes and Damian Perez).

Finally, special thanks to my parents, brothers and sisters for providing continuous support and love, for their belief and encouragement throughout my personal and academic life.

Porto, 2018

Márcio Borgonovo-Santos

List of Publications

This doctoral thesis is based on the following scientific materials:

Full papers

1- Bona, D. D. de; Marques, M. A.; Borgonovo-Santos, M.; Correia, M. V.; **Monitoring of plantar forces and surfboard's movement: Alternative to understand the injuries mechanism.** IEEE International Symposium on Medical Measurements and Applications (MeMeA), Lisboa, 2014, pp. 1-4. doi: 10.1109/MeMeA.2014.6860063 (Appendix I)

2- Borgonovo-Santos, M.; Figueiredo, P.; Vilas-Boas, J. P.; **Surfing Performance: map of scientific knowledge - Systematic Review**
Manuscript submitted for publication

3- Borgonovo-Santos, M.; Telles, T.; Machado, L.; Nessler, J.; Figueiredo, P.; Vilas-Boas, J. P.; **Surf burst paddling: are upper body force related variables associated to body composition and competitive level?**
Manuscript submitted for publication

4- Borgonovo-Santos, M.; Nessler, J.; Vilas-Boas, J. P.; **Ecological validation of the simulated surf pop-up in laboratory conditions.**
Manuscript submitted for publication

5- Borgonovo-Santos, M.; Telles, T.; Nessler, J.; Castro, M. P., Vilas-Boas, J. P.; **Characterization of surf pop-up movement: kinematics and reaction forces.**
Manuscript submitted for publication

6- Borgonovo-Santos, M.; Zacca, R.; Fernandes, R.; Vilas-Boas, J. P.; **Energetic profile of a surfing paddling cycle.**
Manuscript submitted for publication

Patent Application

1- Borgonovo-Santos, M.; Costa, J. A. M. L.; Albuquerque, M. C.; Vilas-Boas, J. P.; **A three dimensional sensor to measure dynamic water flow direction, path and intensity in nautical sliding sports.** Provisional Patent Ref: DP/01/2017/40787

2- Borgonovo-Santos, M.; Costa, J. A. M. L., Albuquerque, M. C., Vilas-Boas, J. P., **SADNA – System of Acquisition Data for Nautical Activities.** Under review by the Innovation Department of Porto University- UPIN.

Conferences

- 1- Abraldes, J. A.; Borgonovo-Santos, M.; Fernandes, R. J.; Vilas-Boas, J. P.; Figueiredo, P., **Surf power paddling: velocity and acceleration analysis** (poster). 2014. J Cult, Cien y Dep. 9 (25), 2014. (Appendix II)
- 2- Borgonovo-Santos, M., Morais, S. T., Castro, M. P., Fonseca, P., Soltani, P., Flores, A., Vilas-Boas, J. P., **Characterization of surf pop-up simulated movement**. XXV Congress of the International Society of Biomechanics in Glasgow in July 2015. (Appendix III)
- 3- Borgonovo-Santos, M.; Figueiredo, P.; Vilas-Boas, J. P.; **Methodology for 3D data analysis of power paddling efficiency in surf**. In: XVI Congresso Brasileiro de Biomecânica, 2015, Florianópolis. Anais do XVI Congresso Brasileiro de Biomecânica. Florianópolis: Sociedade Brasileira de Biomecânica, 2015. (Appendix IV)
- 4- Heck, M. B.; Borgonovo-Santos, M.; **Time motion analysis of competitive bodyboard**. Jovens Investigadores da Universidade do Porto – IJUP2017. (Appendix V).

Table of Contents

| | |
|--|--------|
| Abstract | XI |
| Resumo | XIII |
| Financial Support | XV |
| Acknowledgements | XVII |
| List of Publications | XIX |
| Table of Contents | XXI |
| List of Tables | XXIII |
| List of Figures..... | XXV |
| List of Equations..... | XXIX |
| List of Appendices | XXXI |
| List of Abbreviations | XXXIII |
| Glossary of Terminology..... | XXXV |
| General Introduction..... | 1 |
| Chapter 1 Surfing Performance: map of scientific knowledge – Systematic. | 5 |
| Chapter 2 Surf burst paddling: are upper body force related variables associated to body composition and competitive level?..... | 21 |
| Chapter 3 Ecological validation of the simulated surf pop-up in laboratory conditions..... | 39 |
| Chapter 4 Characterization of the surf pop-up movement: kinematics and exerted reaction forces..... | 49 |
| Chapter 5 Energetic profile of a surfing paddling cycle..... | 67 |
| Chapter 6 Fluid-Flow sensor for nautical sliding sports: a three dimensional transducer to measure direction and intensity of water's dynamic flow..... | 87 |
| Chapter 7 SADNA – System of Acquisition Data for Nautical Activities ... | 95 |
| Chapter 8 The mOceanSense Startup - from the science to the business | 101 |
| Chapter 9 General Discussion..... | 117 |
| Chapter 10 Conclusions | 121 |
| Chapter 11 Suggestions for Future Research | 123 |
| Chapter 12 General References | 125 |

List of Tables

| | | |
|----------------|--|--------|
| Table 2-1. | List of scientific journals, publications and proportion of covered surf studies..... | 11 |
| Table 2-2. | List of all studies included in this review (author, year), with the rationale, findings and published journal. | 11 |
| Table 2-3. | Studied population of surfers | 15 |
| Table 3-1. | Body composition variables values and differences between groups and variables: body mass index (BMI), skeletal muscle mass (SMM), body fat mass (BFM), and waist to hip ratio (WHR). | 31 |
| Table 4-1. | Descriptive values of pop-up performance in the three evaluated situations..... | 46 |
| Table 5-1. | Cross information among <i>surfer's</i> , hand's dominance and stance feet base. | 53 |
| Table 7-1. | Axes deformation, direction of displacement and equations of strain gauges. | 93 |
| Table 9-1. | Product features comparison. | 105 |
| Table 9-2. | SWOT Analysis | 107 |
| Table AP I-1. | CoP displacement considering all trials during tests (1), (2) and (3)..... | XLII |
| Table AP IV-1. | Individual 3D values for X Peak Velocity, X Distance. | XXXVII |
| Table AP IV-2. | Individual 3D values for Y and Z (Range, Standard Deviation and Skewness coefficient) power paddling. | XXXVII |

List of Figures

| | | |
|-------------|--|----|
| Figure 2-1. | Scientific databases' outcomes and the selection process for the articles included in the systematic review..... | 10 |
| Figure 2-2. | Number scientific publications related to surfing performance over the years. | 10 |
| Figure 2-3. | Map of scientific knowledge of surfing performance. | 17 |
| Figure 3-1. | Schematic of tethered surf burst paddling protocol. The surfer is attached to a cable, connected to a load cell (1), which monitors the force/time information to be processed and analysed. The data is representative and shows the maximum and minimum peaks obtained to proceed with descriptive and inferential statistics..... | 26 |
| Figure 3-2. | “A” represents the absolute force while “B” represents the relative force of recreational masters (RM), recreational youngers (RY) and competitive youngers (CY)..... | 29 |
| Figure 3-3. | The relative impulse of recreational masters (RM), recreational youngers (RY) and competitive youngers (CY) in different time intervals: from 0 to 2 s (0-2), 2 to 4 s (2-4), 4 to 6 s (4-6), 6 to 8 s (6-8) and 8 to 10 s (8-10). | 30 |
| Figure 3-4. | The mean velocity of recreational masters (RM), recreational youngers (RY) and competitive youngers (CY). Incremental phase (slope > 1) shows the interval where the velocity increase until reach the stabilized phase, the optimal velocity with small oscillations (slope <1). | 31 |
| Figure 4-1. | Video analysis with zoom-in and timeline in milliseconds. | 43 |
| Figure 4-2. | The setup of four force-platforms covering a two-dimensional outline representation of a typical short surfboard. | 44 |
| Figure 4-3. | Pop-up mean time performance in three different situations: real conditions on Banzai Pipeline and Hossegor, performed by professionals, and the simulated condition in the laboratory, performed by amateurs..... | 45 |
| Figure 4-4. | Representative Force vs. Time curves for each body limb..... | 46 |
| Figure 5-1. | Full-body markers setup: (a) anterior view; (b) posterior view; (c) force plates arrangement and surfboard drawing representation. | 54 |
| Figure 5-2. | The sequence of movements performed: (a) paddle simulation, (b) touch hands on the surfboard, (c) pushing, (d) transition, (e) reaching the surfboard and (f) weight stabilisation..... | 55 |
| Figure 5-3. | Infographic of pop-up movement results. | 62 |

| | | |
|-------------|--|-----|
| Figure 5-4. | Individual phases proportion of the pop-up movement and different transitions technique to achieve the stabilized standing position..... | 63 |
| Figure 6-1. | Rationale of the research showing a model of a surf session energetic profile and our goal line. | 71 |
| Figure 6-2. | A general overview of the tests applied, the sequence of execution and lactate samples. | 72 |
| Figure 6-3. | Tests on the swimming pool: a) tethered paddling; b) lactate sampling; c) endurance test with oximetry and heart rate monitor; d) maximal velocity test. | 75 |
| Figure 6-4. | Tethered-paddling force-time performance (a) and sprint paddling velocity (b) for pre (#1) and post (#2) endurance paddling. (*) non-ordinal force reduction ($p < 0,01$). | 77 |
| Figure 6-5. | Mean values of absolute and maximum heart rate percentage during each minute of the 6 min endurance paddling at 60% of maximal velocity. | 78 |
| Figure 6-6. | Estimated $\dot{V}O_2$ related parameters (mean \pm SD and coefficient of variation) obtained during 6 min paddling at 60% of maximal velocity. A_0 is the $\dot{V}O_2$ at before the endurance test; A_{fc} and A_{sc_end} , TD_{fc} and TD_{sc} are respectively amplitudes and corresponding time delays of the fast and slow $\dot{V}O_2$ components. The CV (%) and 95%CI are the mean coefficient of variation and 95% confidence interval for each mean parameter estimate, respectively. | 78 |
| Figure 6-7. | Lactate curve of the entire protocol. Differences ($p < 0.01$) were found until the endurance-paddling test, after that the values stabilize. | 79 |
| Figure 6-7. | The energy pathways mean values and respective contributions (%) during the entire protocol. | 80 |
| Figure 7-1. | The transducer and the components..... | 92 |
| Figure 7-2. | Schematic of the electronic amplifier circuit | 92 |
| Figure 7-3. | Position and axes orientation to place the sensor and their parts in the surfboard. | 92 |
| Figure 8-1. | Structure of sensors, variables, transformation of variables and transmission. | 100 |
| Figure 9-1. | Ocean pilot study in Nazaré-PT and laboratory analysis with the world champion surfer of giant waves Sebastian Steudtner. Surfboard and prototype assembled. | 104 |
| Figure 9-2. | Competitors..... | 105 |
| Figure 9-3. | Two-in-One prize and recognition. Ricardo Marques representing mOceanSense. | 109 |

| | | |
|------------------|--|---------|
| Figure 9-4. | Diagram of the platform structure..... | 111 |
| Figure 9-5 | Example of GPS information showing wrong information, and our fluid flow sensor measuring the real speed. | 112 |
| Figure 9-6. | mOceanSense team in the Porto Biomechanics Laboratory – LABIOMEPE-UP. | 114 |
| Figure 9-7. | History line of the mOceanSense project. | 114 |
| Figure 9-8. | Research network and partners. | 115 |
| Figure AP I-1. | Force sensors distribution on the surfboard. | XXXIX |
| Figure AP I-2. | Test setup: surfboard with an unbalanced support. | XL |
| Figure API-3. | The mean curves show the Power oscillation related to the respective tests. | XLII |
| Figure AP I-4. | Power oscillation and pitch angle during execution of Test (2). | XLIII |
| Figure AP I-5. | Power oscillation and roll angle during execution of Test (3). | XLIV |
| Figure AP II-1. | The left image shows acquisition of velocity signal and the right image shows tests executed in the swimming pool..... | XXXVI |
| Figure AP II-2. | Full poster presentation..... | XXXVIII |
| Figure AP III-1. | Pop-Up Movement sequence - a) Force plates setup. b) Paddling simulation on the floor. c) Impulsion. d) Flight. e) Reach. f) stabilization. g) Force graph – the contribution of each upper and lower limbs. | XXXVII |
| Figure AP III-2. | Full poster presentation..... | XXXIX |
| Figure AP IV-1. | a) Example of 3D displacement of the surfboard nose during one trial of 5.50 s duration. b) Box-Plots with the entire range of motion, of all subjects, during two trials on the medial-lateral axis (Y). Blue colour represents the best velocity obtained by each subject..... | XXXVIII |
| Figure AP V-1. | Proportion of activities during a body board contest. | XXXVI |
| Figure AP V-2. | Full poster presentation..... | XXXVIII |
| Figure AP VI-1. | Photos that registered the scenes of the documentary..... | XXXV |

List of Equations

Equation (6.1) – Bi-exponential model characterising the exercise $\dot{V}O_2$75

Equation (6.2) – $\dot{V}O_2$ slow component - end of the endurance paddling.....76

List of Appendices

| | | |
|----------------|--|--------|
| Appendix I. | Monitoring of plantar forces and surfboard's movement: alternative to understand the injuries mechanism (full paper) | XXXV |
| Appendix II. | Surf power paddling: velocity and acceleration analysis (conference poster)..... | XXXV |
| Appendix III. | Characterization of surf pop-up simulated movement (conference poster)..... | XXXV |
| Appendix IV. | Methodology for 3D data analysis of power paddling efficiency in surf (conference presentation). | XXXV |
| Appendix V. | Time-motion analysis of competitive bodyboard (conference poster)..... | XXXV |
| Appendix VI. | Terra X - ZDF TV Documentary..... | XXXV |
| Appendix VII. | Ethical Disclaimer | XXXVII |
| Appendix VIII. | Informed consent – laboratory tests..... | XXXIX |
| Appendix IX. | Informed consent – swimming-pool tests..... | XLI |
| Appendix X. | Questionnaire – surfer characterization | XLIII |
| Appendix XI. | Reports – surfer evaluation..... | XLV |
| Appendix XII. | Patent documents | XLIX |

List of Abbreviations

| | |
|---------------|--|
| 3D | Three-dimensional |
| BMI | Body mass index |
| e.g. | <i>exempli gratiā</i> (for example) |
| et al. | <i>et alii</i> (and others) |
| GPS | Global positioning system |
| HR | Heart rate |
| i.e. | <i>id est</i> (it is) |
| LABIOMEPEP-UP | Porto biomechanics laboratory, University of Porto |
| n | Number |
| WHO | World Health Organization |

Glossary of Terminology

The information provided in this glossary of terminology refers to frequent terms used in this manuscript.

| | |
|-----------|--|
| DUCK DIVE | Pushing the board underwater, nose first, and diving under an oncoming wave instead of riding it. |
| DROP | The drop is where a surfer first gets up on the waves and drops down to the face of the wave. |
| FACE | The forward-facing surface of a breaking wave. |
| GOOFY | Goofy footed, surfing with right foot forward. |
| LINE-UP | The area where most of the waves are starting to break and where most surfers are positioned in order to catch a wave. |
| NOSE | The pointy of the surfboard; |
| OUTSIDE | The area beyond the line-up. |
| POP-UP | Describes the move a surfer makes to go from lying on the surfboard, into the standing position to ride a wave. |
| PRIORITY | Which surfer has the right of way. |
| RADICAL | High performance or risk-taking surfing, awesome or impressive. |
| REGULAR | Regular footed, surfing with left foot forward. |
| SURFING | Refers to the act of riding a wave, regardless of whether the wave is ridden with a board or without a board, and regardless of the stance used. |
| SWELL | A series of waves that have travelled from their source in a distant storm, and that will start to break once the swell reaches shallow enough water |
| TAIL | This is the bit of the surfboard at the opposite end to the nose. |
| WIPE-OUT | Falling off the surfboard is referred to as a wipe-out, normally during the drop. |

General Introduction

The worldwide market value for surfing is expected to round about US\$10 billion by 2024, compelled by the popularity of the professional surf, but mainly because of the recreational participants (Global Industry Analysts, 2016). It is not known the number of surfers around the world; a recent data survey points to approximately 23 million practitioners (Statistic Brain, 2018). However, leaving aside the precise numbers and market values, the fact is that surfing, as a sport, is massive and continues to grow.

Another important fact for the surf community happened on August 3, 2016, at the 129th International Olympic Committee Session in Rio de Janeiro – Brazil. Surfing was voted as one of the five new sports included in the program of the Tokyo 2020 Games. Changes on the image and infrastructure (without mentioning social, economic and environmental aspects) are some of the top long-term benefits that the Olympic Games have the power to deliver for rookie sports (IOC, 2012). In short, this event becomes an additive, even greater, in the already exorbitant growth and professionalisation of surfing.

The process of formation, development, and professionalism of surfing is now evident. In order to build global and specific understanding of important aspects of surfing, the contribution of the sports sciences is urgent and mandatory. This is a common endorsement from surf researchers (Coyne et al., 2017; Eurich et al., 2010; Frank et al., 2009; Parsonage et al., 2016).

Limitations in equipment and technologies are still a major obstacle to consolidate advances in the science of surfing. Further, this barrier, which is difficult to transpose, makes problematic to obtain reliable data collected directly on the surfing actuation zone: the ocean. Important part of this information was obtained through the Time Motion Analysis (TMA) (Redd et al., 2016; Secomb et al., 2015b). In all, this evidence provides useful and applicable information for understanding performance across surfers. Furthermore, both knowledge and technological transferences from other sports have been used to provide pioneer results and important reference values (Farley et al., 2016). Although, this tests performed out of the ocean - in laboratory conditions - could weaken the

ecological validity of the information (Araújo et al., 2007; Kvavilashvili et al., 2004).

Measurement devices have started to be used very recently in the sea during surfing. The combination of TMA, Heart Rate (HR) and GPS provided new highlights about energetic demands involved in real conditions of surf practice (Bravo et al., 2016; Coyne et al., 2017; Redd et al., 2016; Secomb et al., 2015b). Despite these applied innovative methodologies, none takes into account the displacement of the water under the surfboard – the water flow, fundamental measure for obtaining the relativisation of the efforts and unbiased information (Grm, 2017).

Exposed the importance and magnitude of Surf, especially with its first debut at the Olympic Games; the lack of scientific studies to understand movements and techniques, to support training methods, to improve equipment and, finally, to create tools and study surfing at sea, this PhD project was developed with the following objectives:

Aims

This research aimed to investigate the horizontal phase and the transition to the standing position in surfing, specifically the sprint paddling, endurance paddling and the pop-up technique. The whole pack under a biomechanics perspective, associated with bioenergetic insights. The general approach was supported by a process of deconstruction of movements and techniques in didactical parts, in order to reconstruct a global knowledge, and a better understanding of surfing. Looking ahead, we aggregate to this project the development of technological resources that make it possible to explore the surf directly in the ocean.

All parts of the work using a holistic approach that incorporates laboratory tests (with and without an analogous and controlled environment), and closing with equipment development for accurate measurements.

The specific aims and the structure of the thesis were as follows:

Chapter 1. Aims and structure of this thesis.

Chapter 2. To identify, synthesize and report scientific evidences related to the surfing performance – Systematic Review.

Chapter 3. To analyse force production during surf burst paddling, comparing different performance levels and body composition.

Chapter 4. To validate the methodology for the simulated surf pop-up on the laboratory floor, which allows acquiring the ground reaction forces of each body-limb, comparing it with video time motion analysis at real conditions.

Chapter 5. To measure kinematics and ground reaction forces during a simulated pop-up movement, and to relate these values with anthropometric characteristics.

Chapter 6. To evaluate the performance of a cycle of surf paddling, under functional and ecological tests: tethered-paddling, maximal paddling velocity, and endurance-paddling.

Chapter 7. To develop a portable sensor for a surfboard fluid analysis.

Chapter 8. To develop a system that combines the 3D inertial motion analysis, GPS and the fluid analysis of surfing.

Chapter 9. Through the analytical information, we begin to disrupt all the paradigms of nautical sports evaluation.

Chapter 10. Provides general discussions about the findings.

Chapter 11. Offers recommendations for future research.

Chapter 12. Mentions the general conclusions of this thesis.

Chapter 13. Show all the references used in this thesis.

The Appendix grouped all relevant materials and documents constructed and gathered during the entire process.

Chapter 1

Surfing Performance: map of scientific knowledge – Systematic Review

Márcio Borgonovo-Santos¹⁻³, Pedro Figueiredo⁴, João Paulo Vilas-Boas^{1,2}

¹ Centre of Research, Education, Innovation and Intervention in Sport, Faculty of Sport, University of Porto, Porto, Portugal.

² Porto Biomechanics Laboratory (LABIOME), University of Porto, Porto, Portugal

³ Surfing Viana High Performance Centre – Surf Club Viana, Viana do Castelo, Portugal.

⁴ Federação Portuguesa de Futebol (FPF), Lisboa, Portugal

Abstract

The surfing performance expresses a combination of diverse scientific and technical fields that integrate the components for the better understanding of this aquatic modality. The main objective of this systematic review was to identify and synthesize all research evidence about surfing performance. A systematic search of multiple scientific databases was undertaken (Academic Search Complete, CINAHL, Web of Science, MEDLINE, PubMed, Scopus, SportDiscus). Relevant material up to March 2018, was identified using the following keywords: (surf OR surfer* OR surfing OR surfboard) AND (strength OR balance OR motion OR assessment OR fitness OR aerobic OR postur* OR physiology OR conditioning OR power OR profile OR tests OR exercise OR maneuver OR "heart rate" OR oxygen OR muscle) NOT (surface OR membranes OR micro* OR cell OR clam). This search and criteria of selection results in 59 articles. A total of 2028 surfers divided in male, female; competitive and recreational were reported. This systematic review allowed to build a map of principal fields of scientific actuation in surfing and helped to verify the rationales, identify tendencies, situate the new findings and recognize some gaps not explored in surf biomechanics.

Key words: Activity profile, evaluation tests, bioenergetics, paddling, training, maneuvers, technique.

Introduction

Recent evidence suggests that approximately 23 million people practice surfing in its various forms across the world (ISA, 2014). Surfing becomes very popular as a sport and is practised by men and women, of all ages, in all continents, as a recreational or competitive activity (Eurich et al., 2010). The International Surfing Association (ISA) was recognized by the International Olympic Committee (IOC), and surfing currently has the participation of 79 nations and hundreds of associations. In this way, surfing is the most popular nautical sport in the world, involving substantial business from different sectors (ISA, 2014). The surfing industry constitutes approximately 5.5% the board sports market and beachwear of the total sports market worldwide (EuroSIMA, 2014).

Despite the popularity of surfing, the scientific research did not follow this remarkable growth. Critical aspects of performance of recreational and competitive surfing are very scarce. This is a wide consensus among authors who provide the first advances in scientific research on this field (Eurich et al., 2010; Everline, 2007; Farley et al., 2012; Frank et al., 2009; Mendez-Villanueva et al., 2005a; Paillard et al., 2011). Due to the number of practitioners in this sport, we can estimate the existence of a substantial number of entities with distinct objectives in surfing. This surf universe ranges from new participants (e.g., didactic-educational, disabilities, etc.), until training professional athletes (e.g., surf schools, professional teams, coaches, etc.). Therefore, for Eurich et al. (2010), from the moment that the process of formation, development, and professionalism of surfing begin to be evident, empowerment of sports sciences contribution is mandatory, both for the overall understanding of this sport and its specificities.

The recent progress in equipment design, also in approaches for teaching and training, resulted in a different surf practice in the last few years (Loveless et al., 2010b; Mendez-Villanueva et al., 2005a). Therefore, it is important to review the scientific knowledge made available until this point. The performance in any sport is the combination of diverse scientific and technical fields that integrate the components for the best understanding of this modality (Rodgers et al., 1984).

The main objective of this systematic review was to identify, synthesise and report scientific evidences related to the surfing performance.

Methodology

Literature Search and Identification

A systematic search of multiple scientific databases, relevant to the sports field, was undertaken using the followed electronic databases: PubMed, Web of Science and Ebsco Host that include SportDiscus; Academic Search Complete; Medline; and CINAHL. Relevant material from the year of their inception up to March of 2018, was identified using the combined structure of the following keywords: (surf OR surfer* OR surfing OR surfboard) AND (strength OR balance OR motion OR assessment OR fitness OR aerobic OR postur* OR physiology OR conditioning OR power OR profile OR tests OR exercise OR maneuver OR “heart rate” OR oxygen OR muscle) NOT (surface OR membranes OR micro* OR cell OR clam). The search was restricted to the keywords present in the title field, and original full scientific papers in English. This structure was built with three strands: the first included relevant surfing keys possibilities; the second concatenates the specific relevant performance parameters; and a third was created to refine the search, ignoring frequent terms from other science fields, reducing the junk items. The structure of terms was based on Rodgers and Cavanagh (1984) and PubMed list of terms.

Reference Manager – The results of each database were exported to the Software EndNote X8 (Clarivate Analytics) and grouped. The software identifies and discards the duplicated references under supervision.

The first selection was based on the titles obtained in the database the articles that presented any possibility of surfers as an object of research (e.g., keywords in the title, comparison of subjects), then the articles were included in the abstracts selection phase.

In the second selection, based on the abstracts review, criteria were established to improve information filtering: a) subjects characteristics – the

studies had to include a surfer practitioner sample or surfer's subpopulation; b) outcome measures – the studies had to report surf-related performance variables (e.g., spatiotemporal, kinematic and/or kinetic; measurements based on transducers, accelerometry, electromyography – EMG –, bioenergetics, etc.). If the articles presented any evidence of surfers as an object of research, these studies were included in the full-text review phase. Also, if the abstract was not sufficiently clear about the selection criteria, the study was included in a full-text analysis.

In the third selection, the full-text review, the two principal characteristics to include one article in this Systematic Review were: a) surf subjects in the methodology; b) any parameters, variables or outcomes related to performance. The exclusion criteria were: whether the articles were not selected in the screening steps (title, abstract and full review), the articles were discarded in the respective step. Review articles also were discarded.

Data extraction was accomplished using the database-filtered information and organized in: timeline publications over the years; journal publications distribution; standard bibliographic references followed by rational, findings and journals; map of surf sport knowledge and the total samples of surfers.

Results

Search outcomes

The search strategy yielded a total of 418 outcomes. The title selection refines to 180 potentially relevant articles. The abstract selection filtered 82 relevant articles, which were considered eligible for inclusion in this review. Finally, the full-text review selected 59 articles that contained the requirements and were included in this review (figure 2-1).

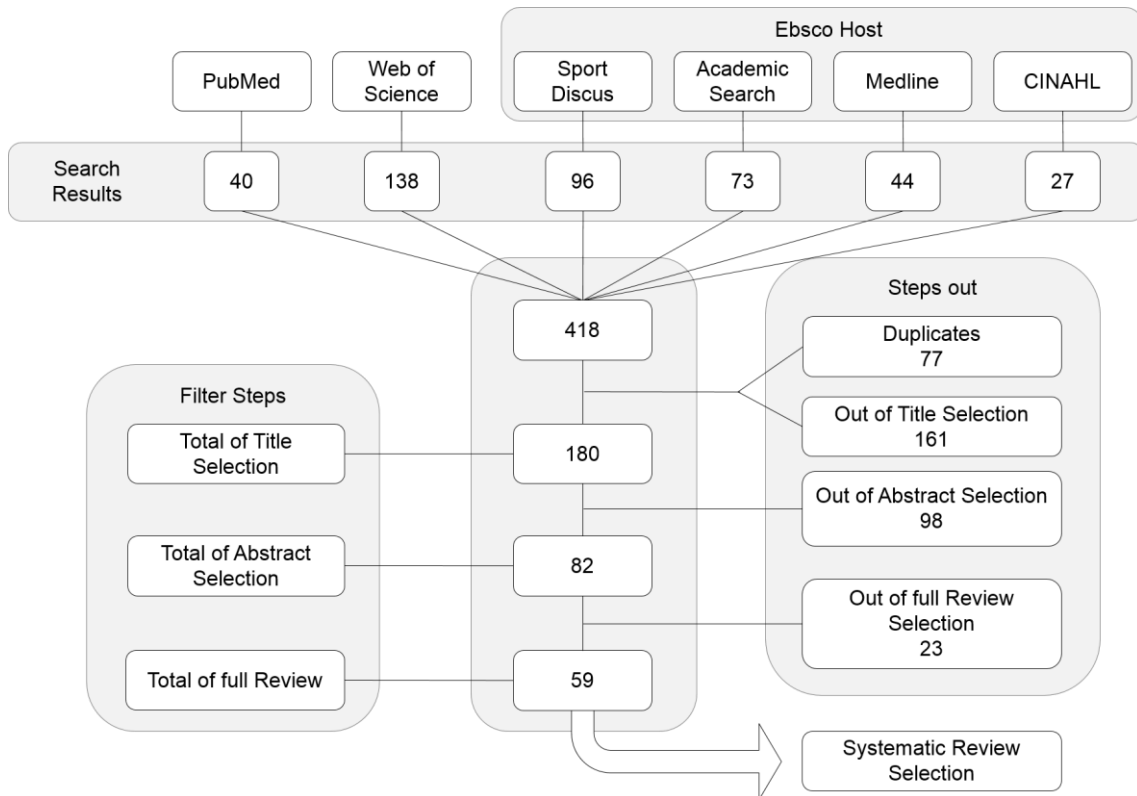

Figure 2-1. Scientific databases' outcomes and the selection process for the articles included in the systematic review.

Recent growth in the number of scientific surfing publications is evident from a time perspective (figure 2-2).

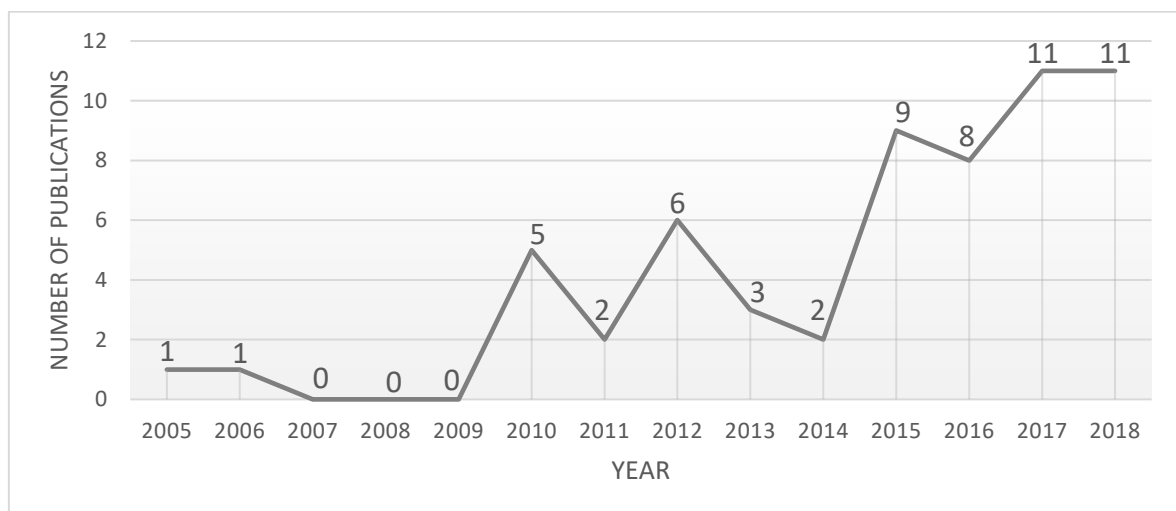

Figure 2-2. Number scientific publications related to surfing performance over the years.

The journals that covered and have the important role of disseminating knowledge of surfing are presented in the table 2-1.

Table 2-1. List of scientific journals, publications and proportion of covered surf studies.

| Journal | Number of Publications | Percentage |
|------------------------------|------------------------|------------|
| J Strength Cond Res | 18 | 31% |
| Int J Sports Physiol Perform | 8 | 14% |
| Int J Sports Sci Coach | 4 | 7% |
| Eur J Sport Sci | 3 | 5% |
| J Sports Sci | 3 | 5% |
| Sports | 3 | 5% |
| Human Movement | 2 | 3% |
| Int J Exerc Sci | 2 | 3% |
| J Sports Med Phys Fitness | 2 | 3% |
| Braz J Kinathrop Hum Perform | 1 | 2% |
| Ergonomics | 1 | 2% |
| Eur J Appl Physiol | 1 | 2% |
| J Aging Phys Act | 1 | 2% |
| J Appl Biomech | 1 | 2% |
| J Hum Kinet | 1 | 2% |
| J Physiol Anthropol | 1 | 2% |
| Laterality | 1 | 2% |
| Percept Mot Skills | 1 | 2% |
| PLoS One | 1 | 2% |
| Rev Bras Med Esporte | 1 | 2% |
| Scand J Med Sci Sports | 1 | 2% |
| Sci Med Sport | 1 | 2% |
| Sports Eng | 1 | 2% |

In the way to synthetize and facilitate the identification of the studies' purposes, a table with the rationale and findings of each study was prepared, including the first author, year of publication and journal (table 2-2).

Table 2-2. List of all studies included in this review (author, year), with the rationale, findings and published journal.

| Authors/Year | Rationale | Findings | Journal |
|-------------------------|---|--|------------------------|
| Alcantara et al. (2012) | To evaluate the balance control. | No relationship between surf performance and balance control. | Rev Bras Med Esporte |
| Anthony et al. (2016b) | Dynamic balance evaluating the influence of stance. | Surf stance play a large role in horizontal and directional balance. | Int J Sports Sci Coach |

| | | | |
|--------------------------------|---|---|------------------------------|
| Axel et al. (2018) | 8-week Core Strength Training Program. | Enhances athletic performance measurements. | Int J Exerc Sci |
| Barlow et al. (2012) | Anthropometric profiles, performance and ability. | Adiposity and muscularity influence the progression from intermediate to professional. | Eur J Sport Sci |
| Barlow (2016) | Anthropometry to predict competitive ranking. | Fat levels are associated with the national ranking. | Human Movement |
| Barlow et al. (2015) | Bioenergetic relation with national British ranking. | Inclusion of power at $\dot{V}O_2$ in assessment batteries. | Human Movement |
| Barlow et al. (2014) | Wave conditions on performance and bioenergetics. | Wave and surfer ability are associated with the physiological response and performance. | J Strength Cond Res |
| Bravo et al. (2016) | Activity profile and heart rates in students. | HRs and durations are consistent with recommendations with cardiovascular fitness and health. | J Strength Cond Res |
| Bruton et al. (2017) | Sex difference in drop landing. | Recreative female showed more upright posture, more ankle and knee angles, and less ankle dorsiflexion at the end of landing than others. | Percept Mot Skills |
| Coyne et al. (2017) | Upper-body strength on paddling. | Short-term exposure to maximal strength training elicits improvements in paddling performance measures. | J Strength Cond Res |
| Coyne et al. (2016) | Anthropometry, upper extremity strength, and surfboard paddling performance. | Competitive and recreational differs in relative arm span and endurance paddle performance | Int J Sports Sci Coach |
| Ekmeçic et al. (2017) | Surfboard volume reduces energy expenditure during paddling. | Increasing surfboard volume reduces the metabolic cost of paddling. | Ergonomics |
| Eurich et al. (2010) | Sex differences in performance of a simulated surfing pop-up movement. | Men produce greater force and power even relative to body weight when performing a simulated surfing pop-up. | J Strength Cond Res |
| Farley et al. (2018) | Activity profile of competitive surfing. | Point-break competition involving longer durations of continuous paddling and short, high-intensity workloads for a beach-break. | J Strength Cond Res |
| Farley et al. (2016) | Sprint-Interval-Training and High-Intensity-Interval-Training on paddling performance. | HIT and SIT improve aerobic and Repeat-Sprint-Paddle ability. Findings indicate that 400-m paddle and RSP Test can discriminate between aerobic and anaerobic adaptations. | J Strength Cond Res |
| Farley et al. (2012a) | Ergometer test for bioenergetics paddling evaluation. | Correlations support the inclusion of anaerobic paddling power in assessment batteries and conditioning practice. | J Strength Cond Res |
| Farley et al. (2012b) | Bioenergetic analysis during competition. | Intermittent high-intensity bouts of all-out paddling intercalated with short recovery periods and repeated bouts of low-intensity paddling, and intermittent breath holding. | J Strength Cond Res |
| Fernandez-Gamboa et al. (2018) | Competition load during a single heat through objective and subjective methods and the relationship with judges' score. | The subjective method assess the heat load. Wave characteristics is an important factor in perceived exertion during competition. | J Strength Cond Res |
| Fernandez-Gamboa et al. (2017) | Lower limb power, competitive level, and association with rankings. | Physical performance works as indicator for ranking positioning. | J Strength Cond Res |
| Fernandez-Lopez et al. (2013) | Morphology associated with paddling test and ranking position. | Blood lactate accumulation and endomorphy should be considered variables that influence performance. | Eur J Sport Sci |
| Ferrier et al. (2018) | The impact of aerial maneuvers on scoring in competition. | Aerial maneuver during award a significantly higher score. | J Sports Sci |
| Forsyth et al. (2018) | Aerial maneuver performance - critical features associated with successful or unsuccessful landing. | Landing over the centre of the surfboard and landing with the lead ankle in dorsiflexion were associated with successful landings. | Scand J Med Sci Sports |
| Forsyth et al. (2017) | Influence of turns, tube rides and aerial maneuvers on the scores. | Completing aerial maneuvers optimize potential single wave scores; lower completion rate. | Int J Sports Physiol Perform |

| | | | |
|----------------------------------|--|---|------------------------------|
| Furley et al. (2018) | Lateral preferences are associated with behavior and performance on the direction of a breaking wave. | Surfers have acquired skills allowing them to compensate for debilitating individual and environmental circumstance. | Laterality |
| Furness et al. (2018a) | A rotator cuff strength testing for surfers and a profile of internal and external rotation strength in a competitive surfing cohort. | The current procedure is reliable with the same clinician, and results indicate musculature asymmetry specific to the external rotators. | Sports |
| Furness et al. (2018b) | A comprehensive physiological profile of both recreational and competitive surfers. | Battery of physiological tests could be used as a screening tool to identify an athlete's weaknesses or strengths. | J Strength Cond Res |
| Khundaqji et al. (2018) | Feasibility of a regression model to predict swim bench ergometer VO ₂ peak values. | VO ₂ peak and peak heart rate were greater on the treadmill compared to the ergometer. | Sports |
| Kilduff et al. (2011) | Association of relative length of the second and fourth digits (negatively related to prenatal testosterone) and performance among male surfers. | In line with other sports that low right second and fourth digits correlates to high surfing ability in men. | J Strength Cond Res |
| LaLanne et al. (2016) | To determine whether activity levels and cardiovascular responses to surfing change with age. | Recreational surfers across the age spectrum are achieving intensities and durations that are consistent with guidelines for cardiovascular health. | J Aging Phys Act |
| Loveless et al. (2010a) | To assess the reliability of peak power output measured during maximal paddling on a swim-bench ergometer. | Maximal-paddling performance can be measured reliably both in the laboratory during swim-bench ergometry and in a swimming pool. | J Sports Sci |
| Loveless et al. (2010b) | To measure and compare peak oxygen uptake and paddling efficiency in recreational and competitive junior male surfers. | Blood lactate threshold, might be better at distinguishing surfers of differing ability. | Eur J Sport Sci |
| Lundgren et al. (2015a) | To develop and evaluate a multifactorial model based on landing performance to estimate injury risk for surfing athletes | Ankle-dorsiflexion, midhighpull lower-body strength, tabilization time during a drop-and-stick landing (DSL), relative peak force DSL, and frontal-plane DSL seems sensitive and easy to implement and interpret. | Int J Sports Physiol Perform |
| Lundgren et al. (2015b) | To describe the impact forces, accelerations and ankle range of motion in five different landing tasks to assist in the prescription of landing task progression and monitoring training load. | Increased task complexity and specificity of the sport increased the tibial peak acceleration, indicating greater training load. | J Sports Sci |
| Mendez-Villanueva et al. (2010a) | Examine the relationship of heart rate reserve and percentage of the oxygen consumption reserve | Heart rate reserve during prone upper-body exercise was not equivalent to its corresponding oxygen consumption reserve. This difference should be considered. | J Physiol Anthropol |
| Mendez-Villanueva et al. (2010b) | Reliability of competitive performance. To determine the typical variation in competitive performance of elite surfers. | Performance scores in surfing competition showed moderate to large variability. | J Strength Cond Res |
| Mendez-Villanueva et al. (2006) | The activity profile of men's competitive surfing. | surfing is an intermittent activity characterized by a large variability and random distribution of each parameter analyzed. | J Strength Cond Res |
| (Mendez-Villanueva et al., 2005) | To evaluate and compare the upper-body aerobic fitness characteristics in 2 groups of competitive surfers with different performance levels. | Better surfers have higher upper body aerobic fitness scores. | Sci Med Sport |
| Minahan et al. (2016) | Determinants of a 30 s sprint-paddling test, varying ability. | A higher peak sprint power and a larger accumulated O ₂ deficit observed in competitive compared to recreational surfers. | Int J Sports Physiol Perform |

| | | | | |
|-------------------|--------|--|--|------------------------------|
| Moreira (2014) | et al. | To use the Matrix of Analysis for Sports Tasks (MAST) and it was based on surf practice classification and task analysis | Surf taxonomy can provide deeper knowledge, and the MAST makes possible the development of strategies that benefit teaching and performance intervention. | J Hum Kinet |
| Nessler (2017a) | et al. | To determine whether changing the foil of a short surfboard will alter paddling mechanics and efficiency | When surfboard volume and gross dimensions are fixed, foil has little effect on the efficiency of paddling a short surfboard in recreational athletes. | Sports Eng |
| Nessler (2017b) | et al. | To determine whether such a vest has an effect on muscle activation and extension of the lower back. | Properly inflated vest can alter trunk extension and muscle activity while paddling a surfboard in water. | J Appl Biomech |
| Nessler (2015) | et al. | Effects of wearing a wetsuit on muscle activation, upper extremity motion, heart rate, and oxygen consumption during simulated surfboard paddling in the laboratory. | A 2mm wetsuit has little effect on the energy cost of paddling at lower workloads but does affect arm motion. | PLoS One |
| Paillard (2011) | et al. | Surfers' postural control and their use of visual information in static and dynamic postures and level of competition | Relationship between the postural ability and the level of surfers. Expert surfers shift the sensorimotor dominance from vision to proprioception for postural maintenance. | Eur J Appl Physiol |
| Parsonage (2018) | et al. | Sex differences of upper-body dynamic strength relative to maximal isometric strength and dynamic skill deficit. | Male and female surfers apply a similar proportion of their maximal strength in sports-specific movements. Relative isometric and dynamic strength in males resulted in greater sports-specific force application and a faster pop-up. | Sports |
| Parsonage (2017a) | et al. | The reliability of the isometric push-up, dynamic push-up, and force plate pop-up as measures of upper-body isometric and dynamic strength qualities in surfers. | Pop-up performance may be elicited by improving dynamic strength for stronger surfers, and the maximum strength for weaker. | J Strength Cond Res |
| Parsonage (2017b) | et al. | Describe and compare the sex differences in physical performance characteristics of elite surfers. | Female surfers may have a greater window for adaptation and therefore vast benefit of targeting their underdeveloped physical qualities. | J Strength Cond Res |
| Pittsinger (2017) | et al. | The effect of a single 30-min surfing bout on exercise-induced affect and changes associated surfing history, frequency, and skill level. | Significant differences between fatigue and surfing history, surfing frequency, and surfing skill level. The results indicate that a single 30-min surfing bout may provide positive benefits for the participant. | Int J Exerc Sci |
| Secomb (2016) | et al. | Lower-body muscle structure and countermovement-jump and squat-jump performance between stronger and weaker surfing athletes. | Strongers appeared to better use their strength and muscle structure for braking as they had significantly higher eccentric peak velocity and vertical displacement during the countermovement-jump. | Int J Sports Physiol Perform |
| Secomb (2015a) | et al. | Associations between lower-body strength and power, and the performance of turning and aerial maneuvers in elite surfers. | Surfing athletes that exhibit greater lower-body isometric and dynamic strength, and power perform higher scoring turning maneuvers during wave riding. | Int J Sports Sci Coach |
| Secomb (2015b) | et al. | Changes in sprint paddling and countermovement-jump performance after training session and physical demands related to the capacities changes. | A considerable reduction in sprint paddling ability and countermovement-jump performance. | J Strength Cond Res |
| Secomb (2015c) | et al. | Descriptive and quantitative time-motion analysis of surfing training using satellite navigation and heart rate measurements. | 2 hours of surfing training session was performed at a lower intensity than competitive heats. Training sessions do not appropriately condition surfers for competitive events. | Int J Sports Physiol Perform |
| Sheppard (2013a) | et al. | Testing protocol for evaluating the physical performances of surfing athletes, including measures of anthropometry, strength and power, and endurance. | Tests were sensitivity to detect changes, and competitively superior junior surfers are leaner and possess superior strength, paddling power, and paddling endurance. | Int J Sports Physiol Perform |

| | | | |
|-------------------------|---|---|------------------------------|
| Sheppard et al. (2013b) | Common and differences in paddling technique across paddle stroke length; torso inclination; and arm recovery. | Sprint paddling is likely best conducted with the surfer's chest low to the board, without considerable extension through the back, and with a low arm recovery. | Int J Sports Sci Coach |
| Sheppard et al. (2012) | To evaluate the potential association with anthropometry and upper-body pulling strength with sprint kinematics of competitive surfers. | Strong association between relative upper-body pulling strength and sprint paddling ability in surfers. | J Strength Cond Res |
| Silva et al. (2018) | Functional movement screen (FMS) scores and physical variables association with surf. | FMS individual scores better explain physical variables than total score. Trunk stability push-up test seems to be a reliable. | J Sports Med Phys Fitness |
| Silva et al. (2017) | To compare physical performance between sex. | Anthropometric, physical fitness, performance variables shows specific intra sex results that should be interpreted by surf coaches. | J Sports Med Phys Fitness |
| Souza et al. (2012) | Bottom turn technique with the scores attributed. | Association between the curve at the bottom of the wave with the results achieved in surfing heats. | Braz J Kinathrop Hum Perform |
| Tran et al. (2015a) | Drop-and-stick (DS) test method to assess dynamic postural control across different surf levels. | Time-to-stabilization and relative peak landing force as a qualitative measure of dynamic postural control using a reference scale to discriminate among groups. | Int J Sports Physiol Perform |
| Tran et al. (2015b) | Validated performance-testing protocol for competitive surfers is able to differentiate between Australian junior national team and those not selected. | Countermovement-jump height; sprint paddle; time to 400 m; and endurance paddling velocity, can discriminate between selected and non-selected competitive surfers. | Int J Sports Physiol Perform |

All of these studies reported different types of surfers of both sex, separately or combined, as well as competitive and recreational levels with complementary information of body mass and height (table 2-3).

Table 2-3. Studied population of surfers

| | | | | Competitive | | | |
|--------|-----|-------------|---------|----------------|---------|------------|-------------|
| | | Age (years) | | Body Mass (kg) | | Height (m) | |
| Sex | N | Mean | Range | Mean | Range | Mean | Range |
| Male | 744 | 21.5 | 15 - 34 | 69.6 | 56 - 80 | 1.74 | 1.66 - 1.80 |
| Female | 106 | 19.7 | 14 - 27 | 57.5 | 51 - 63 | 1.63 | 1.60 - 1.68 |
| Mix | 466 | 21.1 | 14 - 36 | 60.8 | 50 - 75 | 1.68 | 1.59 - 1.75 |
| | | | | Recreational | | | |
| | | Age (years) | | Body Mass (kg) | | Height (m) | |
| Sex | N | Mean | Range | Mean | Range | Mean | Range |
| Male | 554 | 29.8 | 16 - 64 | 75.6 | 65 - 82 | 1.77 | 1.69 - 1.82 |
| Female | 33 | 29.7 | 21 - 33 | 60.4 | 55 - 65 | 1.63 | 1.61 - 1.65 |
| Mix | 125 | 28.1 | -- | 69.6 | -- | 1.72 | -- |

Total of 2028 researched surfers, competitive and recreational from both sex.

The map of scientific knowledge of performance in surfing (figure 2-3) was composed based on the rationales and findings of the 59 studies cited, covering recreational and competitive surfers, as well sex differences.

Discussion

The purpose of this systematic review was to identify performance parameters and findings reported in surf researches. Furthermore, it was also intended to identify research trends, and summarise fields of research inside the surf scientific world. Likewise, it was aimed to situate the new findings and recognise gaps not explored in surf performance scientific studies.

Search outputs

The “surf” keyword it is not a simple research pointer, neither simple to find with good precision when is related to the sport. Surf is a common term to explain movements, displacements or zones in different research areas. For example, in Physiology: surf is associated with the transport mechanisms of molecules; Technology Information: is related to surf-web and navigation controls; Geology and Geography: the term point to surf zones, sections of the sea; Moreover, frequently is associated with many other aquatic sports with or without surfboard: Windsurf, Kitesurf, Stand-up, body surf, etc.

To our knowledge, articles about surfing with relevance in international publications written in English are scarce, except the J. Strength. Cond. Res., that concentrated 18 articles, and the International Journal of Sports Physiology and Performance (8 articles), the remaining articles are distributed in different journals (table 2-1).

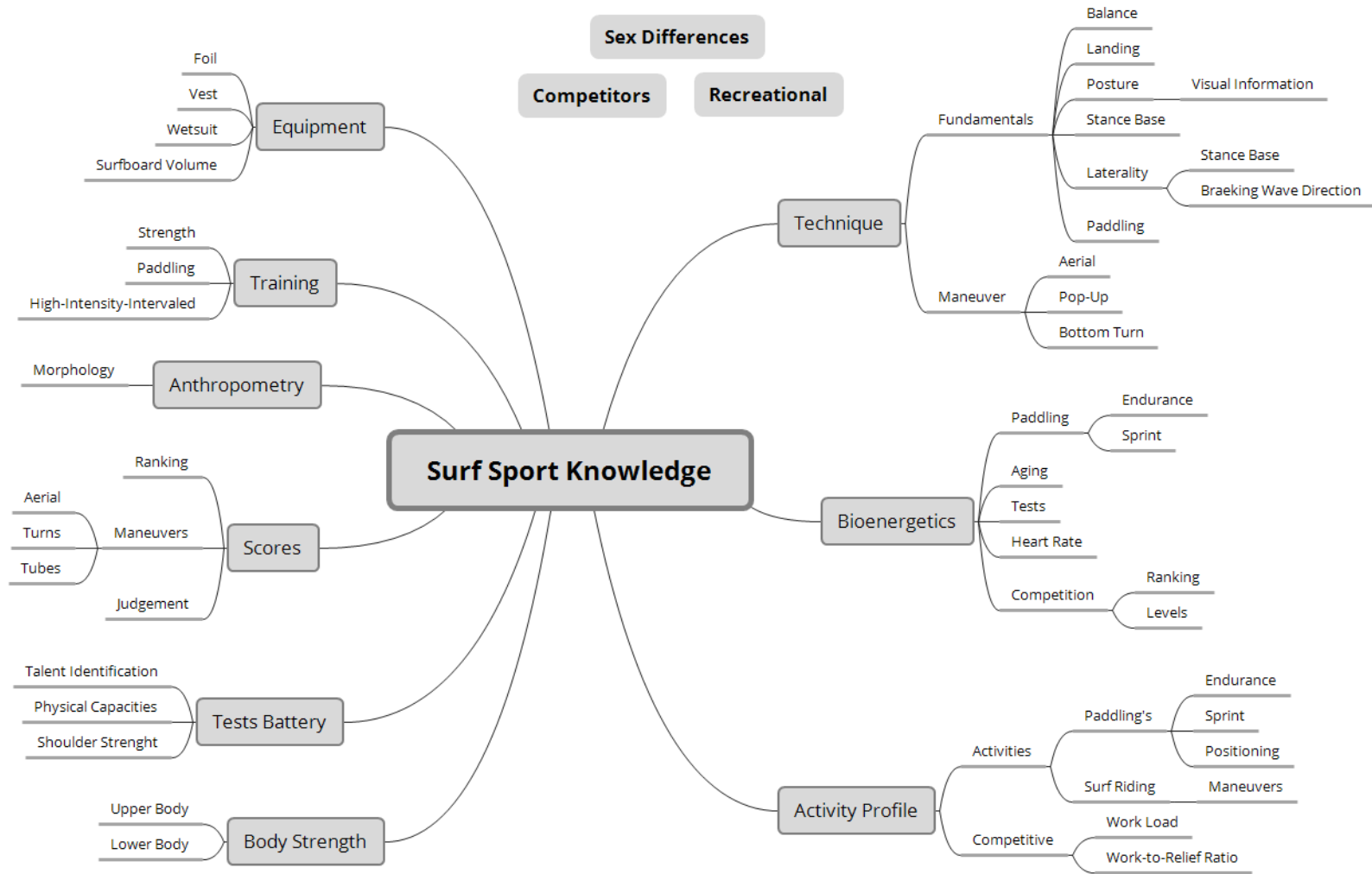

Figure 2-3. Map of scientific knowledge of surfing performance.

The main objectives of the articles already published

Examining the main objectives of the studies, it seems evident a trend to understanding physical characteristics of the upper body. The paddling is the main evaluated activity under bioenergetically perspectives, followed by the pop-up movement. This is likely to be related to the ease of assessing surf paddling in a controlled environment, whether on ergometers or in the pool. Meanwhile, sea assessments have not yet been conducted.

Aspects related to balance, posture, stretching and flexibility also demonstrate to be a concern among the scientists. The studies were directed to the analysis of postural deviations, morphological adaptations connected to the experience and level of practice. Relationships between levels of flexibility and different types of balance also were reported.

Morphology and anthropometry combined in the body composition have also been shown to be an important field for the investigators. Apparently, the research questions point to a better perception of how the body constitution influences surfing performance.

Participant Characteristics

Taking into account the huge estimated number of surfers in the world, the total number of subjects evaluated in scientific researches of surf is still inexpressive. However, the reported findings are important, firstly to build a base of knowledge and reference values about the participant's characteristics in the sport of surfing. Second, for allowing the possibility of comparison among surfers and other populations, making it possible to identify distinctive characteristics in surfing. The female population was even less reported, making difficult to make significant inferences.

Map of scientific knowledge of performance in surfing

Technique appears to be the most diversified field; 19 studies evaluated the fundamentals and specific maneuvers of surf in their protocols. Bioenergetics comes second with more exhaustive researches, especially on the paddling of surfing. In this sense, evaluating workloads, oxygen consumption and heart rate during specific tests (principally in land ergometers), training cycles and competition.

Studies involving the paddling's stands out for the ease of evaluation in controlled environments like land ergometers, swimming pools and swim flume tanks. In sequence, the "Activity Profile" was one of the first studied fields in surfing. These pioneers gave the possibility of knowing the sequences and demands of activities that occur during a surf session. However, in the most recent studies, technological resources such as GPS and cardiac monitors already add more details of information about surf sessions.

Strength studies are divided into upper body and lower body, following the two main phases of surfing, horizontal and vertical. During the horizontal or prone phase, the upper body is dominant (core, trunk, upper limbs, paddling's). Meanwhile, during the vertical or standing position, maneuvers and movements are dependent on the lower body (countermovement jump, landings, aerials, bottom turns).

Testing batteries appear in order to detect talents, as well to evaluate physical performance to support decision making in training programs, and also correlating skills with scores. In this way, judgments and scores also have some relevance in the sense of checking the best punctuated maneuvers, consistency of scores and the ranking of surfers.

Anthropometrical evaluations seek to characterize the profile of recreational and competitive, male and female surfers. Also, associating this information with performance and bioenergetics parameters. Few studies have attempted to relate these aspects to health and aging indicators.

All these topics are now supporting training interventions. However, longitudinal studies following surfers are scarce. The description of the activity

profile, principally regarding the intensity and intervallic actions, supported new training methodologies that proof bioenergetics and physical improvements.

Limitations

The studies included in this review were diversified and fragmented, with no consistency to deeply characterise specific fields. Moreover, the fact that the studies in question used different research questions and methodologies, it is difficult to compare results and to draw firm conclusions for further recommendations. The first article that fulfilled the inclusion criteria of this study is dated from 2005. However, the number of publications with surf is increasing. This demonstrates that this modality also awakens scientific curiosity, which tries to answer important questions, both for general and specific issues.

Conclusion

The limited variety of outcomes reported were not sufficiently strong to explain or characterize specific surf activities, not even comprehensive to describe general aspects of surfing. Although this systematic review may assist scientists to identify tendencies, and rapidly verify the rationale, situate the new findings and recognise strong points and some gaps not explored in surf performance.

Chapter 2

Surf sprint paddling: are upper body force related variables associated to body composition and competitive level?

Márcio Borgonovo-Santos¹⁻³, Thiago Telles^{1,4}, Leandro Machado^{1,2}, Jeff Nessler⁵, Pedro Figueiredo⁶, Ricardo Fernandes^{1,2}, João Paulo Vilas-Boas^{1,2}.

¹ Centre of Research, Education, Innovation and Intervention in Sport, Faculty of Sport, University of Porto, Porto, Portugal.

² Porto Biomechanics Laboratory (LABIOMEPE), University of Porto, Porto, Portugal

³ Surfing Viana High Performance Centre – Surf Club Viana, Viana do Castelo, Portugal.

⁴ Laboratory of Aquatic Activities, Physical Education Faculty, Sports Science Department, State University of Campinas, Campinas, Brazil.

⁵ Department of Kinesiology, California State University, San Marcos, CA, USA

⁶ Federação Portuguesa de Futebol (FPF), Lisboa, Portugal

The first author had the financial support of CAPES-BRAZIL. Processes “BEX 0819/2014” and “99999.005005/2014-00”

Manuscript submitted for publication.

Abstract

Several powerful sprint arm strokes are performed to achieve the required velocity to catch waves in surfing. The purpose of this study was to analyse tethered propulsion-force production and velocity of sprint-paddling, comparing different performance levels and body composition. Three groups: recreational master - RM (age: 37.6 ± 6.1 years old; body mass: 78.8 ± 7.6 kg; height: 1.77 ± 0.08 m), recreational young - RY (age: 21.0 ± 3.4 years old; body mass: 65.2 ± 10.9 kg; height: 1.74 ± 0.08 m), and competitive young - CY (age: 14.6 ± 1.3 years old; body mass: 56.7 ± 8.7 kg; height: 1.68 ± 0.09 m). Tests took place in a 25 m pool and consisted of a ten seconds maximal effort attached to a load cell through a non-elastic cable. Normalized force was the main variable that differs between groups. The CY surfers showed higher mean values for relative impulse. The force declined over time in all groups and in a similar way. Body composition was similar between groups. RM surfers differ (higher) for body mass index, percentage of body fat mass and waist to hip ratio. The CY surfers are capable to achieve more relative force during the sprint paddling, while the older surfers have high percentage of body fat mass.

Keywords: surfing, tethered paddling, force, anthropometrical profile, body composition.

Introduction

The ability to paddle a surfboard is vital to a surfer's success in the ocean. This skill provides both aquatic locomotion as well as the ability to manoeuvre into the best position to catch waves. Paddling is performed in the prone position on the surfboard, using mainly the upper limbs, and requires the integration of several additional complex skills, such as postural control, balance, and coordination (Mendez-Villanueva et al., 2005a). Previous studies have shown that the mean ratio of surf activity in the water, regardless of the practice level, is relatively consistent. Whether for recreational practice (Meir et al., 1991), training session (Secomb et al., 2015b) or competition (Farley et al., 2012; Mendez-Villanueva et al., 2006), as a rule, surfers spend ~50% of their time paddling, ~40% stationary, ~3% wave riding, and ~7% in miscellaneous activities. In all situations, surfers typically engage in paddling activity for the greatest duration of their time in the water.

A recent study (Secomb et al., 2015c) divided the action of surf paddling into three categories (represented as a percentage of paddling time in the water): a) paddle to return to the line-up (i.e., paddle to the surf zone, where the waves start to break) - 20.9%; b) sprint-paddle to the wave (i.e., burst paddling to catch the wave) - 4.1%; and c) general paddling (i.e., moving around the lineup) - 17.6%. The remaining time is related to the values summarization from the different cited studies. In general, this type of aquatic locomotion often incurs high inertial loads, which must be overcome by forces produced by the surfers' upper limbs muscles. However, paddling intensity can vary considerably across these conditions, suggesting that a broad range of physical demands, such as elevated levels of muscular strength, power, cardiovascular endurance, and dynamic postural control, are required during an average surf session or competition (Barlow et al., 2015; Loveless et al., 2010a; Mendez-Villanueva et al., 2010a; Secomb et al., 2015c). Therefore, athletes and researchers should consider multiple facets of human performance to gain a broad understanding of a surfer's paddling ability.

Paddling into and around the line-up, i.e., the cited categories a) and c), contribute for the majority of paddling activity (approximately 38.5% of the time in water), and requires a high degree of endurance and efficiency. These paddling bouts are typically longer in duration and lower in intensity, but are still an important aspect of a surfer's performance. Increased paddling endurance can often improve positioning in the line-up and may lead to very specific advantages. These include sitting deeper on the peak, receiving the first choice of wave section, paddling against a current to maintain one's position in the line-up, and the ability for faster entry speed (Sheppard et al., 2013b; Tran et al., 2015). For recreational surfers, these positioning dynamics may help them to catch more waves because priority is given to the surfer better positioned in the lineup to catch waves, an unwritten rule that is respected by the majority of surfers. For the competitive surfer, the priority is granted to the surfer that can paddle quickly and reach the outside first.

Sprint-paddling to catch a wave accounts for the smallest percentage of paddling activity, but requires the greatest level of upper extremity strength and power and it's crucial for catching the wave (Coyne et al., 2017). When the surfer is well positioned in the line-up, and a wave is coming, several powerful sprint arm strokes are performed to allow the surfer to develop speed at a critical moment. This action, combined with the use of the wave slope and gravity to propel the surfboard on the face of the wave, is the primary mechanism by which a surfer catches a wave. Therefore, strength and power are both key aspects of a surfer's ability to gain a positional advantage, to ensure fast entry speed into waves, to optimize position on the wave and to catch waves with accuracy (Mendez-Villanueva et al., 2005a; Mendez-Villanueva et al., 2005b; Sheppard et al., 2013b). Further, sprint-paddling performance in surfers was shown to be strongly associated with normalized upper-body pulling strength (Barlow et al., 2014; Sheppard et al., 2012c). Others have reported similar findings (Loveless et al., 2010b) using land adapted ergometers to simulate surf paddling while associating the load parameters with physiological parameters.

Scientific interest in surfing performance is increasing, yet several significant gaps exist in the literature. In particular, the relationship between force

and velocity parameters of surf paddling are not well understood. This information would be useful for surfers and coaches involved in the design of training programs and may assist in the talent identification. Tethered test in swimming, is widely used to establish a relationship between strength, propulsion and velocity (Morouço et al., 2006). A previous study (Lowdon et al., 1989) used the tethered surf-paddling, though the purpose of this experiment was to observe electrocardiogram signal changes.

The purpose of this study was to analyse upper-limbs propulsion-force generation, to correlate with the resultant sprint-paddling velocity, comparing these results across surfers of varying age, performance level and body composition profile.

Methods

Subjects

Thirty-three surfers volunteered to this study, and were divided in 3 groups (each group with 10 males): recreational master (RM) (age: 37.6 ± 6.1 years old; body mass: 78.8 ± 7.6 kg; height: 1.77 ± 0.08 m; time of practice: 18.2 ± 10.4 years; arm span: 1.81 ± 0.07 m), recreational young (RY) (age: 21.0 ± 3.4 years old; body mass: 65.2 ± 10.9 kg; height: 1.74 ± 0.08 m; time of practice: 6.7 ± 4.4 years; arm span: 1.74 ± 0.08 m) and competitive young (CY) (age: 14.6 ± 1.3 years old; body mass: 56.7 ± 8.7 kg; height: 1.68 ± 0.09 m; time of practice: 3 ± 1.1 years; arm span: 1.73 ± 0.13 m). Surfers were considered master if they were 30 years of age or older, and competitive if they participated in surfing competitions.

Experimental Procedures

The local Ethics Committee approved the experimental procedures. Before the surf tests, the surfers were submitted to anthropometric evaluation and body composition, examined in the standing position. Body composition assessment was performed through multifrequency bio-impedance analysis using the InBody 230 (Biospace Co., Ltd., Seoul, Korea). The body composition

tests included body mass index (BMI), percentage of skeletal muscle mass (SMM%), percentage of body fat mass (BFM%), and waist to hip ratio (WHR).

In order to simulate the surf environment, the tests took place in a 25 m indoor swimming pool (27 °C of water temperature), and the surfers performed the activities with their personal surfboard to minimize constraints. A standard warm-up was performed (Loveless et al., 2010b), consisting of self-stretching exercises; 3 min light-intensity continuous paddling, followed by a 30 s rest, then three 5 s maximal-intensity paddling efforts followed by a 10 min rest. After the warm-up, a belt was attached around the lumbar-sacral area, connected to a 5 m length non-elastic steel cable coupled to a load cell fixed in the pool wall (Morouço et al., 2011; Morouço et al., 2012) (figure 3-1). Immediately prior to the starting signal, surfers adopted a horizontal position on the surfboard with the cable fully extended. Data collection began when the first stroke cycle was completed. This procedure was used to avoid the inertial effect of the cable extension usually observed immediately before or during the first arm action (Morouço et al., 2012). Each participant performed tethered surf paddling at all-out intensity for a period of 10 s, while they were verbally encouraged to paddle as hard as they could for the entire trial. The test ending was indicated through an acoustic signal.

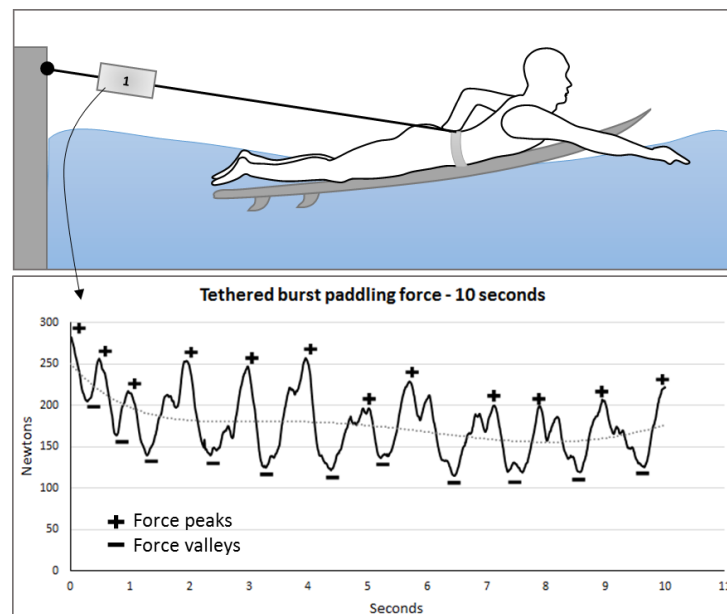

Figure 3-1. Schematic of tethered surf burst paddling protocol. The surfer is attached to a cable, connected to a load cell (1), which monitors the force/time information to be processed and

analysed.

The data is representative and shows the maximum and minimum peaks obtained to proceed with descriptive and inferential statistics.

The load cell system (5000 N, Globus, Italy) used to measure force parameters was recording at 100 Hz, and connected to an analogic/digital data acquisition system Biopac MP150, (Biopac©, USA) with the software Acknowledge 4. All data signal recorded were cleaned with a digital low-pass filter with 10Hz cut-off frequency after the acquisition, to remove noise and artefacts generated from movement. The load cell was calibrated using a double validation method, with standard weights and verified with a universal testing machine (Electro Puls 1000, Instron, Boulder, MA, USA) in tensile and compressive strength test cycles. The force variables (figure 3-1) obtained in individual force-time curves were: maximal force (F_{max}) as the higher value obtained; mean force (F_{mean}) as the average of all values registered; average of force peaks (F_{peaks}) and average of force valleys ($F_{valleys}$) and the difference between F_{peaks} and $F_{valleys}$ (F_{range}). The impulse was calculated using numerical time integration of force values. In order to measure the time course of force development and maintenance, force profiles were clustered in intervals of two seconds (0-2, 2-4, 4-6, 6-8 and 8-10). All force variables were scaled to the surfer's individual weight, and normalized variables were nominated with the prefix "N".

After an interval of 10 minutes, the maximal velocity test was performed. Surfers assumed a prone paddling position on their surfboard, without contact with the wall. Following the start signal, surfers paddled freely across the pool with maximum intensity. Velocity was recorded using a cable speedometer device (Lima, 2006). This instrument uses a bobbin with a non-elastic line that is fixed to the surfer's clothing with a clip in the middle of the lumbar region. The speedometer was placed on the pool wall, about 0.3 m above the water surface. Continuous velocity data were obtained during 10 s at a 50 Hz frequency, exported to the Acknowledge 4 software, and filtered with a 15 Hz cut-off digital filter (FIR - Window Blackman -61dB). The cut-off value was selected based upon FFT analysis to minimize artefact noise. The velocity variables obtained in individual velocity-time curves were: mean velocity (V_{mean}), maximal

instantaneous velocity (v_{max}). Through the linear regression processing two distinct phases were identified by the curve slope: incremental phase (v_{inc} , slope >1), stabilized phase (v_{stab} , slope <1).

Statistical Analysis

Statistical analysis was carried out using Statistica 12 software (StatSoft®, Tulsa, USA). An algorithm for identifying maximum and minimum force/time curve peaks was developed in the Excel 2013 - VBA package (Microsoft Corp., Redmond, WA). To analyse, respectively, the differences between force parameters and body compositions between groups, two separate one-way analysis of variance (One-Way ANOVA) tests were used. To analyse the differences between impulse intervals and groups, a Repeated Measurements ANOVA (RMANOVA) and Fisher LSD *post-hoc* test were used. All prerequisites (normality, homogeneity and sphericity) were satisfied. A significance level (α) of 0.05 was used. Partial eta squared (η^2) was reported as the estimate of effect size. Correlation and multiple regression analyses were conducted to examine the relationship between force, velocity, and various potential performance predictors.

Results

Propulsion Force

Performance level and age groups presented similar values for absolute force parameters $F_{valleys}$, F_{max} , F_{peaks} , F_{mean} , F_{range} (figure 3-2 A). In contrast, the normalized force parameters (figure 3-2 B) showed significant differences in $NF_{valleys}$ [$F(2, 27) = 4.98$; $p = 0.01$; $\eta^2 = 26\%$], NF_{peaks} [$F(2, 27) = 5.22$; $p = 0.01$; $\eta^2 = 28\%$] and NF_{mean} [$F(2, 27) = 5.98$; $p < 0.01$; $\eta^2 = 30\%$]. These parameters indicated higher values for CY compared with RM group.

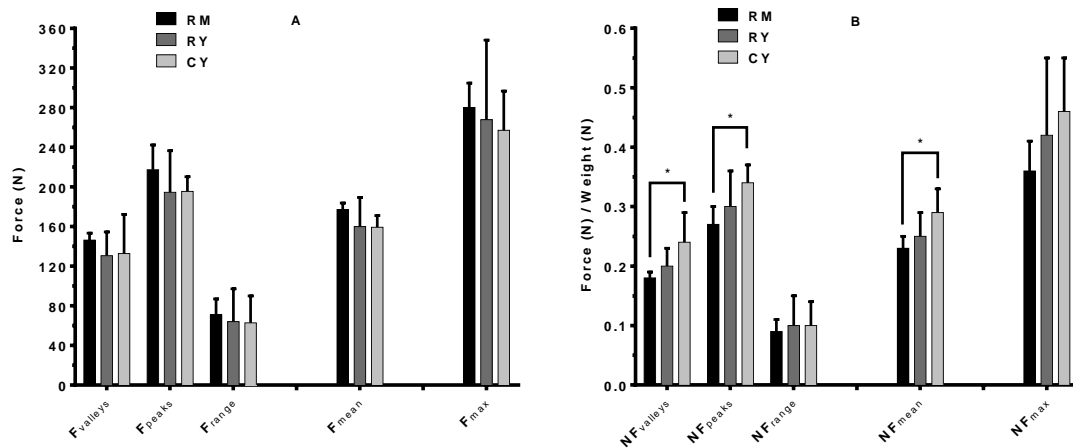

Figure 3-2. "A" represents the absolute force while "B" represents the relative force of recreational masters (RM), recreational youngers (RY) and competitive youngers (CY).

The inferential statistics did not show interaction between groups and time-intervals for the normalized impulse results. However, the main effect for groups (figure 3-3) showed significant differences [$F(2, 27) = 5.97$; $p < 0.01$; $\eta^2 = 31\%$]. The normalized impulse values were significantly higher for CY group. The main effect for the time-intervals also showed significant differences [$F(4, 108) = 27.02$; $p < 0.01$; $\eta^2 = 50\%$], in which the normalized impulse for the first interval (0-2 s) showed higher mean values. It also revealed that the values of the second interval (2-4 s) were significantly higher than the two last intervals (6-8 and 8-10 s). Then, the third interval (4-6 s) also presented significantly higher mean values than the last interval (8-10 s).

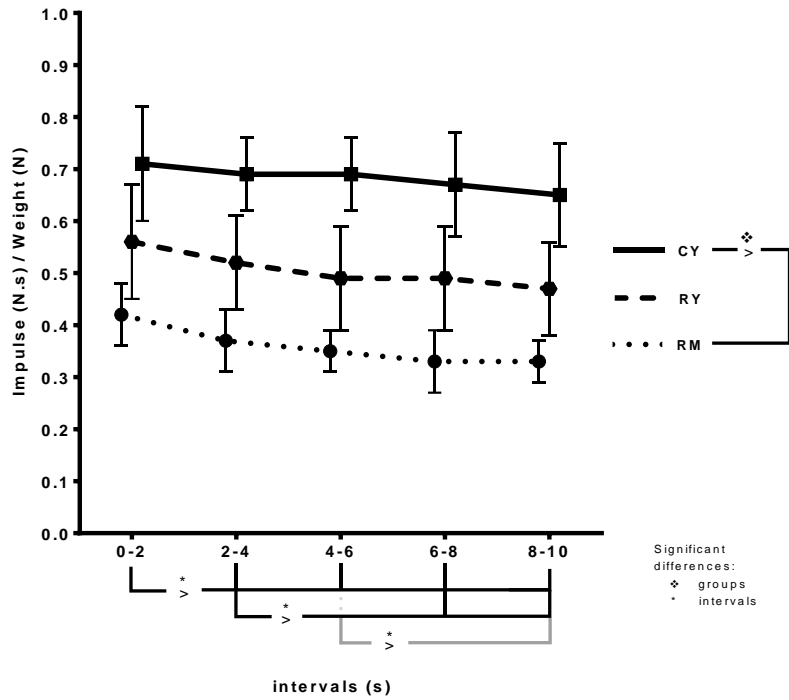

Figure 3-3. The relative impulse of recreational masters (RM), recreational youngers (RY) and competitive youngers (CY) in different time intervals: from 0 to 2 s (0-2), 2 to 4 s (2-4), 4 to 6 s (4-6), 6 to 8 s (6-8) and 8 to 10 s (8-10).

Velocity

The mean velocity found for the groups were (figure 3-4): RY 1.56 m/s \pm 0.10; CY 1.54 m/s \pm 0.14; and RM 1.45 m/s \pm 0.10. The linear regression slope allows to divide the velocity curve into: (a) incremental phase (slope >1): 0 up to 4 s; and (b) stabilized phase (slope <1), 4 up to 10 s. The F_{mean} and V_{inc} were positively and significantly correlated (Spearman 0.43, $p < 0.05$).

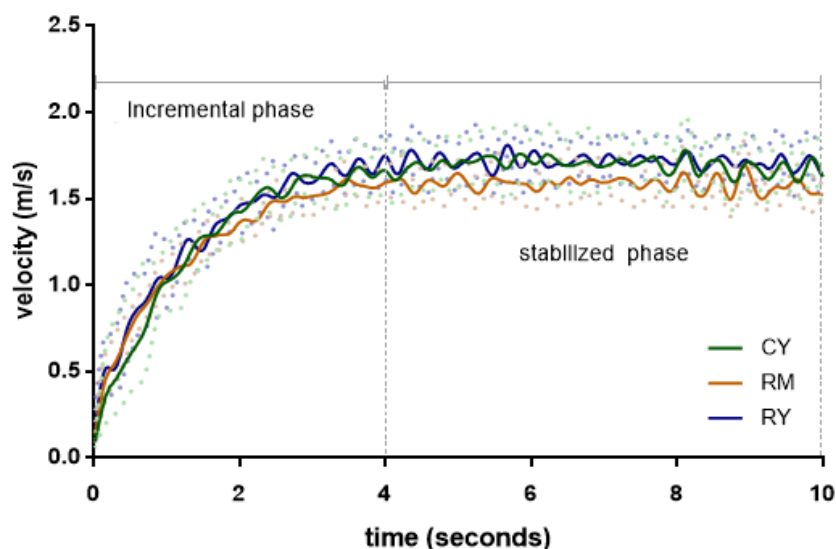

Figure 3-4. The mean velocity of recreational masters (RM), recreational youngers (RY) and competitive youngers (CY). Incremental phase (slope > 1) shows the interval where the velocity increase until reach the stabilized phase, the optimal velocity with small oscillations (slope <1).

Body Composition

The results for body composition parameters (table 3-1) showed significant differences between groups: BMI [$F(2, 27) = 16.48$; $p < 0.01$; partial $\eta^2 = 55\%$]; BFM% [$F(2, 27) = 8.01$; $p < 0.01$; partial $\eta^2 = 37\%$] and WHR [$F(2, 27) = 12.55$; $p < 0.01$; partial $\eta^2 = 48\%$]. The groups RY and CY showed similar mean values for these parameters. The differences primarily occurred between RM and the others, where this group showed higher mean values. The SMM% was similar between groups.

Table 3-1. Body composition variables values and differences between groups and variables: body mass index (BMI), skeletal muscle mass (SMM), body fat mass (BFM), and waist to hip ratio (WHR).

| GROUPS | *BMI | SMM% | *BFM% | *WHR% |
|----------------|-------------------------|------------|-------------------------|-------------------------|
| RecMaster (%) | 25.1 ± 1.4 \uparrow | 47.2 ± 8.1 | 17.6 ± 3.1 \uparrow | 89.5 ± 3.4 \uparrow |
| RecYoung (%) | 21.4 ± 2.4 \downarrow | 50.9 ± 4.0 | 11.9 ± 4.6 \downarrow | 84.2 ± 4.5 \downarrow |
| CompYoung (%) | 20.1 ± 2.1 \downarrow | 49.6 ± 2.4 | 11.0 ± 4.1 \downarrow | 80.8 ± 3.8 \downarrow |
| P value | < 0.01 | = 0.37 | = 0.01 | < 0.01 |

* - Significant differences.

The multiple regression model with age, arm spam, MME%, MG% and NF_{mean} produced $R^2 = 0.24$, $F(5,24) = 1.54$, $p < 0.22$. The NF_{mean} values had significant positive regression weights ($\beta = 0.57$, $b = 1.68$, $p = 0.03$), indicating surfers with higher normalized mean force produced more incremental velocity.

Discussion

The purpose of this study was to analyse propulsion force related variables and paddling velocity during sprint-paddling in surf, and comparing these variables across surfers of varying age, performance level and body composition profile. These data demonstrate that the tethered surf-paddling test can be used to effectively determine sprint-paddling force in surfers. This measurement is sensitive enough to distinguish between surfers of varying age and ability, and to determine declines in force over a 10-second bout of all-out paddling. While measurement of absolute force seems to favour larger, master surfers, normalization of force to individual body weight provided a robust, sensitive, and non-biased means of paddling assessment across all levels and ages of athletes studied.

Absolute Force

Absolute paddling force is the maximum amount of force exerted with the upper limbs on the water to propel the surfer with the surfboard, regardless of muscle mass or body size. The current results showed a trend for higher mean values in recreational masters (not meaningful) when compared to the other groups. This tendency seems to be related to body mass, but not associated with the surf skill level. Basic body dimensions such as mass and skeletal size have a strong influence on muscular strength application (Bassey, 1998). Therefore, larger individuals with higher body mass, in general, are typically endowed with greater potential to generate propulsive force. Moreover, previous study of the upper body Wingate anaerobic test suggests that arm lean body mass is the best predictor of peak anaerobic power in physically active men (Lovell et al., 2013).

From a coaching perspective, the absolute values of force reported here might be useful for providing normative values (athletic profiling), for selecting young athletes, for distinguishing among different performance levels, and for evaluating the effects of physical exercise or athletic training programs (Jaric, 2002). These data may also be useful for comparison with other aquatic sports, like swimming, where a primary focus of upper extremity strength training is also to propel one's with respect to water. Relationships between sprint swimming velocity and maximum forces obtained through tethered swimming have been reported for the front crawl, a swimming technique that shares many similarities to surf paddling (Morouço et al., 2012). More broadly, the average values found in the literature for peak force in swimming ranged from 100 to 350 N (Morouço et al., 2011; Neiva et al., 2011) and are similar to those reported here, despite differences about the legs contribution, in buoyancy and drag forces likely experienced during surfboard paddling.

Relative Force

Relative or normalized strength during paddling is the amount of force exerted by the upper limbs on the water, scaled to the surfer's body weight. The relationship between absolute and normalized force is determined, in part, by the level of homogeneity of the sample (Sheppard et al., 2012c). For example, in a homogeneous population of surfers with similar age, and fitness, both the absolute and normalized forces would theoretically be similar. In a more heterogeneous sample of surfers, these values would likely exhibit larger differences. This can be seen in the current data, where differences among groups in absolute force were not notably different, while the normalized results were higher for the CY group with respect to the RY and RM groups. The normalized force is, therefore, most useful as a mean to compare surfers with different morphological and physiological characteristics.

The tethered paddling test is limited to measurement of propulsive force in surf paddling, and does not directly measure upper extremity strength. However, it is reasonable to suggest that higher propulsive forces are indicative of higher

relative paddling strength across surfers under similar paddling conditions. Assessment of normalized force is therefore relevant because increases in paddling velocity are related to more proficient positioning and wave catching ability, as well as better control and coordination with the surfboard at the key moment of catching a wave (Everline, 2007). Properly timed and executed burst paddling can make a large difference in positioning to the surfer during “take-off,” the critical instant that the wave wall grows and the slope of the water accelerates the surfboard to a speed that allows the surfer to stand up.

Force Duration

Data from an earlier study (Mendez-Villanueva et al., 2006) suggests that burst paddling has a short duration, lasting up to 10 s, depending upon the ocean conditions. A similar duration was utilized here, and for the current analysis, the total time of the normalized impulse was divided into five intervals of 2 s. The data for all groups showed a clear decreasing trend for impulse across time, with the highest impulses generated during the first 2 seconds of the burst paddling (Fig 3-3). This is not surprising, as power output has been shown to decline rapidly during bursts of anaerobic activity for several types of movement (Lovell et al., 2013). More interesting, however, is the trend for CY to maintain their paddling impulse for a longer duration when compared to the other groups. Conversely, the rate of decrease in impulse across the all time intervals was not different between the RM and RY groups. Overall, the subjects studied here exhibited a decrease in mean impulse between 8 and 17% during the 10 s interval. Previous studies of upper body motion have reported steeper declines in power output over time, though these have not been measured for surfers or swimmers (Lovell et al., 2013).

Our data suggest that energetic considerations are important to performance during sprint-paddling and, therefore, to the sport of surfing in general. A previous study (Lovell et al., 2013) of upper body motion using a cycle ergometer has indicated that relative contributions from anaerobic and aerobic energy systems differ from profiles commonly observed in the lower limbs.

Specifically, the anaerobic lactic energy system was reported to provide approximately 60% of the energy required for a 30 s test for the upper limbs, with the aerobic system providing only 11.4% (Lovell et al., 2013). In the lower limbs, aerobic contribution has been reported to be 18-29% (Bencke et al., 2002), and differences between upper and lower limbs may be due to the fact that the upper body has a higher percentage of type II muscle fibres (Sanchis-Moysi et al., 2010). This should be considered when subjects perform the tethered paddle test, as contributions from the lower limbs (i.e., kicking water) may present a challenge to estimating contributions from individual energy systems and should be carefully controlled.

While the upper limbs Wingate test provides a relevant comparison to the current analysis, this test is typically performed over a 30 s interval and the tethered paddle test utilized here was only 10 s in duration, which was due to surf specificity. This difference in duration also holds implications for the study and interpretation of energy use. In particular, it is likely that phosphocreatine stores, which seem to be depleted at around 10 s of maximal activity (Bogdanis et al., 1994), provide a relatively larger amount of energy during the paddle test compared to the longer Wingate test. Additional study of energy use during sprint paddling is needed to fully understand the energetic demands of this activity, and the tethered paddling test may provide a convenient and reliable means to acquire this type of data in future studies.

Velocity

Unlike the force parameters described above, velocity did not differ among groups studied here. More specifically, all surfers were very consistent in their performance: acceleration occurred during the first 4 seconds of their sprint paddle, and upon reaching max velocity all surfers exhibited a comparable amount of variation in their velocity, or “slope”. Since force parameters were acquired during a separate paddling trial and while surfers were stationary, direct analysis of the association between paddling force and velocity was not possible. However, some important assumptions might be drawn from these data. For

example, the data clearly indicate that the first 4 seconds of a sprint paddle are the most important to achieve an appropriate speed to catch a wave. Maintenance of this velocity beyond the first 4 seconds may be less important since it is likely that the wave itself will provide additional propulsion once the surfer reaches their top velocity. This idea is supported by the force data, which demonstrates that propulsive force is greatest at the beginning of the trial and decreases as the trial progresses. This behaviour may be a function of training specificity, as surfers have adapted to catching waves by generating peak forces initially and for a brief period of time, but then allow the wave to perform additional work after the first few seconds of paddling. From this perspective, a 10 s sprint or tethered test may be of too great a duration to accurately reflect a typical sprint paddle in the ocean.

Regarding sprint-paddling, our data suggest that surfers and coaches should focus their attention in training to decrease the time to achieve maximum velocity and maintain the optimal velocity longer. These might include the ability for a surfer to out-maneuvre other surfers for the priority position to catch a wave, or for burst paddling to avoid a breaking wave, an action that might occur while a surfer paddles out into the line-up. Additional research is needed to further clarify the optimal training techniques and how they might affect acceleration and maintenance of paddling velocity in the water.

Body Composition

This study also provides a characterization of the body composition of three different groups of surfers, relative to their surf performance level and age (Table 1). All the results found for body composition parameters were considered in the healthy zone, according to the World Health Organization. Three of the parameters studied (BMI, BFM%, and WHR), were higher for the RM (older) group. These results are consistent with previous literature for other groups of adults (Bae et al., 2013). However, SMM% was not different across groups, and this may be due to regular participation in surfing related activity by RM.

Surfing activity is an intermittent exercise that comprises bouts of high-intensity exercise interspersed with periods of low-intensity activity and rest (Alcantara et al., 2012; Everline, 2007; Lowdon, 1983; Lowdon et al., 1989). Riding waves requires balance, force development, flexibility, reaction time and coordination (Mendez-Villanueva et al., 2006). The duration of surfing practice typically ranges from 20 min in a competitive situation to over 4-5 hours during a good wave condition practice session (Frank et al., 2009; Mendez-Villanueva et al., 2005a). It is a consensus that regular participation in physical activity programs helps to maintain lifelong skills (e.g., strength, power, steadiness and balance) (Haskell et al., 2007). Therefore, it might be possible to infer that regular surfing practice could contribute to maintaining skeletal muscle mass (SMM%), even under the effects of ageing (Frank et al., 2009).

Limitations and considerations

This work analysed the performance of surfers in a swimming pool, which is somewhat different from paddling in the ocean. In particular, salt water generates greater buoyant forces relative to fresh water, and these differences in buoyancy may contribute to differences in drag force and paddling thrust and subsequent velocity. In addition, the tethered force test utilized a stationary paddling paradigm, which is different from an actual paddling burst where the athlete is moving relatively to the water and, as a consequence, limb movement relative to the water are also different, with assumed consequences on hydrodynamic propulsive force generation. However, limitations in equipment have precluded testing in the ocean, and the analyses described here were performed under highly controlled and repeatable conditions, which are very difficult to achieve in the ocean. Further, the paddling motions analysed here, while differing slightly, were still biomechanically very similar to those performed in the open water. In all, these methods provide useful and applicable information for understanding burst paddling performance across surfers of varying ages and performance levels.

Surf burst paddling performance is an indispensable skill for catching waves. The tethered paddling test was shown to be an effective measure of the force parameters generated during this activity. In particular, when the force data were compared across surfer's performance level and body composition profiles, this analysis was sensitive enough to distinguish between surfers of differing body morphology and ability. Further, the force versus time intervals analysis throughout the test may contribute to an improved understanding of upper extremity strength. The velocity data showed that the first four seconds are used to achieve the velocity, with the additional time devoted to maintaining velocity while the wave is caught.

Finally, these data also suggest that long-term participation in surfing may help to preserve muscle mass as an individual ages. Together, these findings may have implications for the design of sport-specific training programs for surfers, and may provide validation of the tethered paddling test as an assessment of paddling ability.

Conclusions

Propulsion force, body weight and resultant velocity are an interdependent triad. Individual body weight was considered an important parameter to provide robust, sensitive, and non-biased surfer sprint-paddling evaluation. Higher relative propulsion forces affect directly the slope of the incremental velocity, reaching the optimal state faster. The skeletal muscle mass percentage was identified as common parameter of body composition across surfer's groups, indicating that surfing practice could contribute to maintaining muscle mass, even under the age effects. These findings may improve the performance of technical and tactical sprint paddling skills. Further research related to the energy pathways are recommended.

Chapter 3

Ecological validation of the simulated surf pop-up in laboratory conditions.

Márcio Borgonovo-Santos¹⁻³, Jeff Nessler⁴, João Paulo Vilas-Boas^{1,2}.

¹ Centre of Research, Education, Innovation and Intervention in Sport, Faculty of Sport, University of Porto, Porto, Portugal.

² Porto Biomechanics Laboratory (LABIOMEPE), University of Porto, Porto, Portugal

³ Surfing Viana High-Performance Centre – Surf Club Viana, Viana do Castelo, Portugal.

⁴ Department of Kinesiology, California State University, San Marcos, CA, USA

Abstract

Replicating sports actions in laboratory conditions preserving the ecological constraints imposed to real practice is, in general, a hard task, even more for surf, considering the particular variability of the ocean conditions. The purpose of this work is to validate a methodology for simulated surf pop-up on the laboratory floor, which allows acquiring the ground reaction forces of each body-limb, relating it with video time-motion analysis of real conditions. For the video time-motion analysis, twenty-three male elite professional surfers were selected (age: 28.1 ± 4.7 years old, body mass: 75.9 ± 6.2 kg; height: 1.79 ± 0.07 m). At the simulated pop-up on the laboratory conditions, twenty-three male amateur surfers participated (age: 28.4 ± 10.1 years old; body mass: 68.3 ± 10.8 kg; height: 1.73 ± 0.07 m; time of practice: 12.4 ± 8.9 years). A Factorial ANOVA was used to compare the pop-up performance between competitive and simulated conditions. No differences were found. Three types of pop-ups were identified on the ocean video inspection: overlap, wipe and grabbed. The laboratory ground reaction forces analysis identified: a) Push-phase (0.71 ± 0.08 s) with similar impulses for both hands; and b) Reaching-phase (0.48 ± 0.22 s) with higher impulse on the front foot. The similar values for the simulated pop-up velocity and real conditions give an initial and promising support to the representativeness of the laboratory motion simulation. The applied methods provided useful and applicable information for understanding pop-up technique performance among surfers.

Keywords: surf, pop-up, surf ecological validation, surf simulation.

Introduction

The inability to systematically evaluate performance on the real conditions is a common problem for many sports (O'Shea et al., 2017), while for surfing this is even more complicated than for the majority of other sports. This is partly related to the difficulty in implementing solutions of performance evaluation whether in the surfers, in the equipment or in the environment itself. Meanwhile, all piece of equipment installed on the real practice conditions represents a constraint, and compromise, more or less, the ecological validity of the analysis (Araújo et al., 2007). On the other hand, the salt water represents a big challenge for the electronic components, which are the greatest source of possible measurements. Normally, these type of devices must be properly protected from the water and, of course, minimally affecting the task performance.

The “pop-up” is defined as a technique used for the quick transition from the paddling position to a standing position, where the feet must be upheld on the surface of a surfboard in a sliding movement (Eurich et al., 2010; Everline, 2007; Hammer et al., 2010; Mendez-Villanueva et al., 2005a). From the point of view of difficulty level and complexity, surfers must still perform this movement in distinct oceanic conditions, which normally change both within and between surf sessions. These conditions comprise differences in wave size, displacement velocity, and form, often determined by the direction of the swell, bathymetry of the break, the period, size, and the state of the tide (Wilson et al., 2014).

In particular, the breaking wave generates challenges that cannot be replicated in simulated conditions, and the relevance of these ecological disturbances cannot be estimated. However, on the dimension of representativeness, simulations replicate the basic components and aspects of the movement under investigation, which are reliable when compared with its arrangement and occurrence on the natural environment (Kvavilashvili et al., 2004).

The main purpose of this work was to validate a methodology for simulated surf pop-up on the laboratory instrumented floor, which allows acquiring the ground reaction forces (GRF) of each body-limb through a special setup of force-

platforms. This will be attempted in this first approach through the comparison of time-motion analysis of with real condition ones.

Methods

This study has an observational, exploratory, and descriptive design that compares two methodologies for the surf pop-up analysis. Firstly, the video time-motion analysis reflects the natural way to perform the activity preserving all ecological factors, without external interference. The second method, the simulated movement in laboratory standardized conditions, allows acquiring ground reaction forces and time variables were taken from a special multiple force-platforms (FP) setup.

We hypothesise that mean time duration of the pop-up manoeuvre in the laboratory conditions would not differ from the natural competition environment, as well as they are not different from competition to competition, despite the challenges imposed by different ocean conditions probably differ.

Experimental Procedures

For the video time-motion analysis, twenty-three male elite professional surfers were selected (age: 28.1 ± 4.7 years old, body mass: 75.9 ± 6.2 kg; height: 1.79 ± 0.07 m). These surfers were analysed in two events of the world championship tour 2017: Hossegor Nouvelle - France, and Banzai Pipeline - Hawaii, organized by the World Surf League (WSL). These two specific beaches were intentionally selected because they offer different conditions for wave's formation, consequently different possible ways to approach the wave.

For the simulated pop-up on the laboratory conditions, twenty-three male amateur surfers (age: 28.4 ± 10.1 years old; body mass: 68.3 ± 10.8 kg; height: 1.73 ± 0.07 m; time of practice: 12.4 ± 8.9 years) volunteered to take part in the study. The hand's dominance was registered using the Dutch Handedness Questionnaire (van Strien, 2003). As an inclusion criterion, participants had surfed for at least 2 years with a minimum regular practice of once a week. Exclusion criteria reject any serious musculoskeletal injuries in the last 6 months.

Video time-motion analysis – On field observation.

The public videos from the mentioned events were assessed on the WSL YouTube channel with the quality of 1280x720 pixels and 30 frames/s. Through the software, Magix Movie Edit Pro – Version 16, videos were manipulated to zoom-in the surfer as an object of inspection (figure 4-1). The initial and final events of the pop-up were identified, resulting in the parameters of total-time of movement, the technical approach used, the number of waves surfed, and the pop-up failures (wipeouts). The beginning of the pop-up was defined as the instant where the surfer touches at least one hand on the surfboard, with the supposed intention to push-up. The end of the movement was defined as the moment when the surfer touches the front foot on the surfboard. One visually clear pop-up per surfer was selected for each competition.



Figure 4-1. Video analysis with zoom-in and timeline in milliseconds.

Simulated pop-up on the laboratory conditions

Ground reaction force data were obtained using a four force platforms setup (figure 4-1). Two of the force platforms FP1 and FP2 had dimensions of 60 x 40 cm; and the other two FP3 and FP4, 60 x 90 cm (Bertec, Columbus, USA).

The force platforms were mounted flush with the laboratory floor, and ground reaction force data was acquired at 1000 Hz. The two-dimensional outline of a typical short surfboard (6 foot 2 inches in length) was drawn on the laboratory floor using tape. The image was built such that each of the four force platforms used was positioned in a quadrant of the board and could register the force generated by each upper and lower limb in action during the pop-up action (figure 4-2).

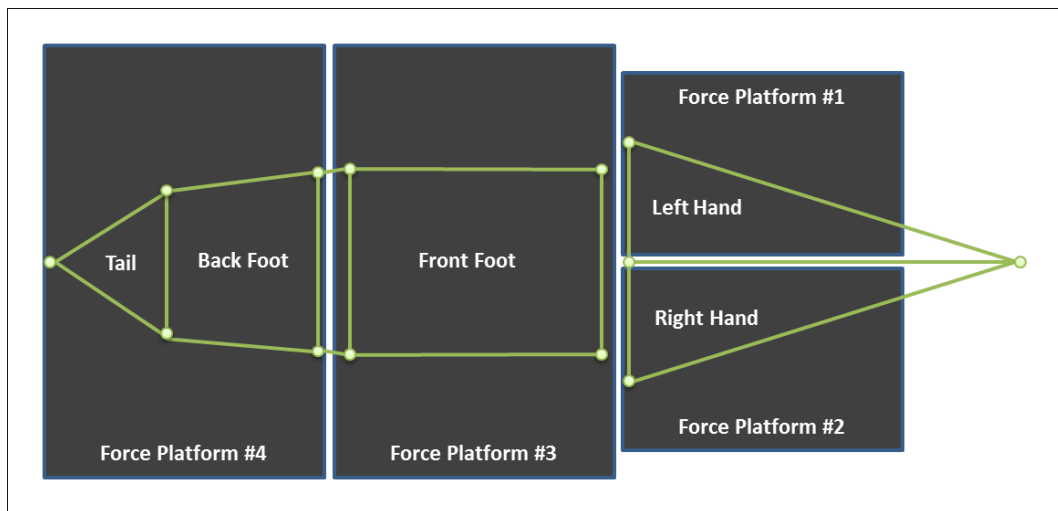

Figure 4-2. The setup of four force-platforms covering a two-dimensional outline representation of a typical short surfboard.

The surfers were instructed to familiarise themselves with the representative surfboard and force platforms and to adjust their prone position according to their personal preferences. The researcher then explained the procedures for simulating the pop-up movement freely, while respecting the surfboard dimensions on the floor. First, the surfers were asked to simulate 3-4 paddling movements, followed by placement of their hands on the surfboard as they might do while performing the pop-up. At this moment, the recommendation was to approach the surfboard with both hands on the FP1 and FP2. If surfers did not follow this procedure, adjustments were made by asking the surfer to move fore or aft along the surfboard representation. Following this familiarisation period, surfers were allowed to perform the entire pop-up motion freely, without any restriction from the researcher.

Statistical Analysis

Statistical analysis was carried out using Statistica 12 software (StatSoft®, Tulsa, USA). All variables were reported with descriptive statistics (mean and standard deviation). To analyse the differences between the pop-up performance (total-time) comparing the two competitions, and also the simulated conditions, a Factorial ANOVA was used. All prerequisites (normality, homogeneity, and sphericity) were satisfied. A significance level (α) of 0.05 was used.

Results

The comparison between the pop-up time performance between the two competition events and the simulation on laboratory do not show significant differences, $F(2, 44) = 1.26$, $p = 0.29$ (figure 4-3).

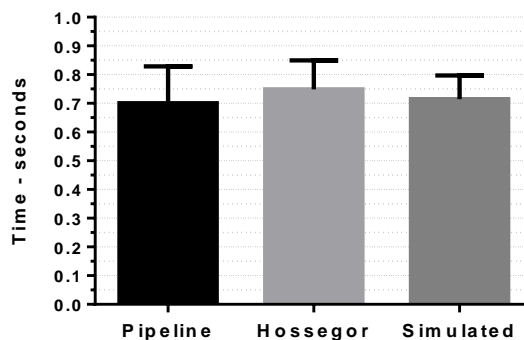

Figure 4-3. Pop-up mean time performance in three different situations: real conditions on Banzai Pipeline and Hossegor, performed by professionals, and the simulated condition in the laboratory, performed by amateurs.

Three types of pop-up's were identified through visual inspection at the natural environment conditions: a) Overlap – while the upper-limbs pushing up the trunk, alongside this, the lower limbs were positioned for the stand position; b) Wipe – the actions of hands pushing and arrange the feet on the surfboard, happens in sequence and c) Grabbed – the surfer maintain one hand on the edge of the surfboard, on the way to counter-balance the body weight on the surfboard during the wave-drop.

Table 4-1. Descriptive values of pop-up performance in the three evaluated situations.

| Parameters | Pipeline HAW | Hossegor FRA | Lab simulation |
|---------------|-----------------|-----------------|-------------------|
| Mean time (s) | 0.701 ± 0.128 | 0.749 ± 0.101 | 0.714± 0.082 |
| Slower (s) | 0.968 | 1.000 | 0.950 |
| Faster (s) | 0.434 | 0.601 | 0.570 |
| Wipeouts | 5 | 0 | -- |

The ground reaction forces (figure 4-4) analysed allowed to identify with accuracy two didactical phases of the pop-up technique: a) Push-phase (0.71 ± 0.08 s) - the interval between at least one hand touch the surfboard, until both hands leave the surfboard and b) Reaching-phase (0.48 ± 0.22 s) - the time between the first feet touch the surfboard to body weight stabilization.

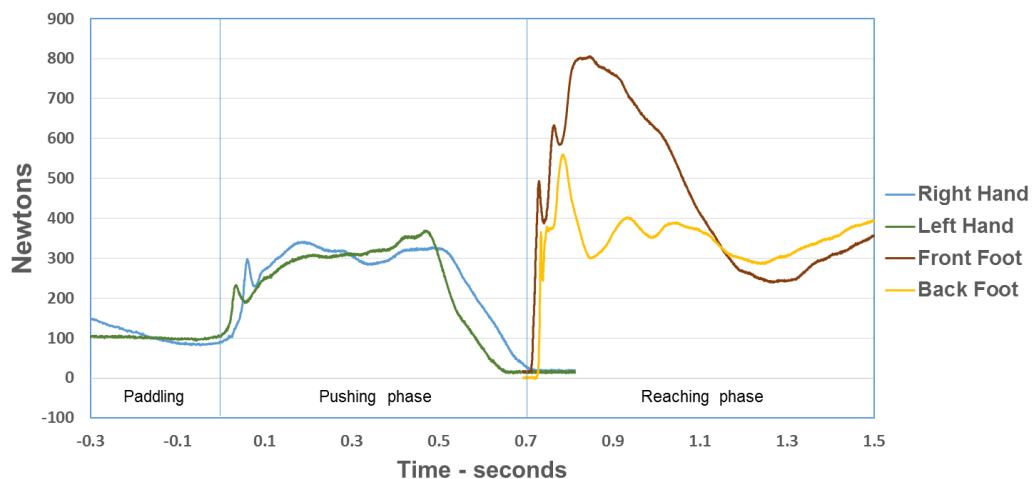

Figure 4-4. Representative Force vs. Time curves for each body limb.

The average of impulse during the pushing phase was 0.30 ± 0.05 N.s/Weight, for the dominant hand, and 0.29 ± 0.07 N.s/Weight for the non-dominant hand. For the reaching phase, the average of impact absorption was 0.32 ± 0.11 N.s/Weight for the rear foot and 0.81 ± 0.13 N.s/Weight for the front foot.

Discussion

The main purpose of this work was to extract the surf pop-up parameters from video time-motion analysis of real conditions and compare them with laboratory simulations.

Limitations in equipment have precluded the performance evaluation using quantitative and precise parameters in the ocean. Basically, the process of training, coaching, and judgment during competitions are based on empirical knowledge, observation, and experience. However, the laboratory apparatus evolved oppositely. Nowadays, the technology has sufficient sophistication to analyse the human body movement with detail and accuracy. Thus, the biggest problem of the laboratory context is to mimic and reproduce the real conditions (i.e., to respect ecological validity) and do not interfere with the performance (Araújo et al., 2007).

Different waves represent different challenges and strategies to perform the pop-up (Coyne et al., 2017; Eurich et al., 2010; Hammer et al., 2010; Redd et al., 2016). Pipeline and Hossegor show different types of oceanic floor and produce different types of waves (Harris et al., 2015). The Banzai Pipeline has reef breaks, and the waves break over a rock bottom. This means that the seabed is thus permanent, and the line-up moves only in accordance with the size and direction of the swell. At Hossegor, the waves break over a sand bottom. In other words, the seabed shifts easily, meaning the shape and quality of the waves are not fixed, but liable to changes. The above mentioned suggests that it is almost impossible to reproduce in laboratory conditions the real water ambient, particularly the changes in the wave shape and behaviour found in different oceanic conditions. As so, this very large ecological variability determines serious limitations to laboratory exploration of surfing. Nevertheless, the late still the only available solution to assess some relevant variables, such the characteristics of forces produced during the pop-up technique.

The pop-up time performed by the professionals and amateurs were similar. Nevertheless, in Banzai Pipeline beach the surfers suffered eight wipeouts during the pop-up execution, while in Hossegor beach no wipeouts were

registered for this sample (table 4-1). This evidence supports the hypothesis of different difficulty levels to perform the pop-up in real conditions. In this way, the similar values for the simulated pop-up velocity, in laboratory conditions, validate the perspective of time-motion representativeness during the simulation, together with the motor behaviour transference. The correspondences are explained by cognitive motor states that activate motor systems in the brain, that are equivalent to those triggered during real conditions (O'Shea et al., 2017). However, the simulation does not take into account the challenges offered by the ocean. This might be particularly important once allowing for matching professional and amateur performances. Indeed, once the pop-up performance at the lab may appear less difficult it allows more and less experts to perform closely, making possible to compare their results, at least for this first attempt for validations of laboratory testing conditions. Meanwhile, the ground reaction force curves showed new parameters and didactical phases that could help understand the physical fitness needs and the pop-up execution process that surfers must attain for the real conditions.

Conclusion

The applied methods provided useful and applicable information for understanding pop-up technique performance of surfers. Both time-motion-analysis and laboratory simulation are complementary to the overall technique study and understanding. The video time-motion analysis made possible to extract parameters and identify how the technique was performed in real conditions. Thus, the simulated methodology apparently preserves the motor behaviour of the surfers, and throughout highly controlled and repeatable conditions, allowing to analyse details that are very difficult to identify in the ocean, which may be highly relevant for training purposes.

Chapter 4

Characterization of the surf pop-up movement: kinematics and exerted reaction forces.

Márcio Borgonovo-Santos¹⁻³, Thiago Telles^{1,4}, Jeff Nessler⁵, Marcelo Peduzzi Castro⁶, Ricardo Fernandes^{1,2}, João Paulo Vilas-Boas^{1,2}.

¹ Centre of Research, Education, Innovation and Intervention in Sport, Faculty of Sport, University of Porto, Porto, Portugal.

² Porto Biomechanics Laboratory (LABIOMEPE), University of Porto, Porto, Portugal

³ Surfing Viana High Performance Centre – Surf Club Viana, Viana do Castelo, Portugal.

⁴ Laboratory of Aquatic Activities, Physical Education Faculty, Sports Science Department, State University of Campinas, Campinas, Brazil.

⁵ Department of Kinesiology, California State University, San Marcos, CA, USA

⁶ Laboratory of Aquatic Biomechanics, Santa Catarina State University, Florianópolis, SC, Brasil.

The first author had financial support of CAPES-BRAZIL. Processes “BEX 0819/2014” and “99999.005005/2014-00”

Abstract

The surf pop-up is a highly unique and challenging skill, critical to successful surfing. Hypothesising that anthropometric characteristics of surfers influence the pop-up performance, we aimed, in this study, to measure kinematics and ground reaction forces (GRF) during a simulated pop-up motion, and to relate these values with anthropometric characteristics. Twenty-three male surfers (age: 28.4 ± 10.1 years old; body mass: 68.3 ± 10.8 kg; height: 1.73 ± 0.07 m; time of practice: 12.4 ± 8.9 years; arm-span: 1.75 ± 8.9 m) perform a simulated pop-up in the laboratory, while GRF and 3D motion capture data were acquired. The duration of the pop-up was 1.20 ± 0.19 seconds (60% push-up and 40% reaching/landing phase). During the push-up, the hands were placed 0.46 ± 0.05 m apart and generated a relative total peak-force of 0.99 ± 0.10 N/Weight, with symmetrical impulse (50%) of 0.30 ± 0.05 N.s/Weight for the dominant, and 0.29 ± 0.07 N.s/Weight for the non-dominant hand. Elbow angles were similar during the peak force application (respectively $110 \pm 18^\circ$ vs $112 \pm 18^\circ$) of the push-up phase. During the landing phase, the feet were placed 0.63 ± 0.10 m apart and generated a relative peak-force of 1.63 ± 0.18 N/Weight. The impact force during landing was applied unevenly between the rear foot (28%) and the front foot (72%). An inverse relationship was found between muscle mass and total duration of the pop-up ($r = -0.50$; $p = 0.01$), but no other relationship was found between anthropometry and performance.

Keywords: surf, pop-up, take off, kinematics, biomechanics.

Introduction

Wave riding is the essence of surfing, but the successful performance of this highly advanced motor skill cannot be achieved without first completing a series of complex tasks in a dynamic and unstable environment. The “pop-up,” defined as a quick transition from the prone to standing position on a surfboard, is one such task that is critical to surfing performance. While the pop-up motion can be isolated and examined in the laboratory, it occurs in the water as a seamless extension of the paddling motion performed as a surfer catches a wave. While positioning for a wave, several quick and powerful paddling strokes are needed to attain enough speed to allow the wave’s energy to propel the surfer and surfboard forward and down to the face of the wave. As the wave is caught, there is a brief but crucial moment during which the surfer must quickly pop-up and begin to perform manoeuvres on the wave (Eurich et al., 2010; Everline, 2007; Hammer et al., 2010; Mendez-Villanueva et al., 2005a).

The pop-up motion represents a unique challenge to the human motor system, as it must be performed quickly, with sufficient force, on a moving and unstable surface (Eurich et al., 2010). Adding to this challenge, surfers must learn to successfully perform the pop-up across a wide range of conditions that can change both within and between surf sessions. These conditions include differences in wave size, speed, and shape, often determined by the bathymetry of the break, the period, size, direction of the swell, and the state of the tide (Wilson et al., 2014). In addition, the successful surfing performance might be influenced by external factors including environmental changes, such as wind and water temperature (Everline, 2007), as well as internal factors, including strength, fatigue, balance, and thermoregulation (Lowdon, 1983; Rochelle et al., 1978). Finally, surfers may choose to ride surfboards of differing size, shape, and density, and must, therefore, adjust their paddling and pop-up behaviour accordingly.

The biomechanics of the pop-up motion is interesting and unique. The first action of the technique consists of the athlete using the upper limbs to push against the deck of the surfboard to propel their centre of mass upward relative

to the surfboard. Male surfers were previously shown to exert an average of 95% of body weight while pushing with their arms during a simulated pop-up in the laboratory (Eurich, 2010). While no data currently exists to characterise the entire movement, it is likely that this motion is not symmetrical, since a surfer must adopt either a “regular” or a “goofy” stance on the surfboard. Regular surfers place the left foot toward the surfboard nose, while a goofy stance uses the right foot in the front of the surfboard. This stance is most often a half-squatting position with knees flexed. While standing the rear knee normally is often stressed in a valgus position due to navigate the accelerating surfboard as it gathers down the wave (Everline 2007).

The complexity of the technique, added to the intervening factors, makes the degree of difficulty for its execution quite high for beginners and challenging even for the most experienced waterman. To date, most research in surfing has focused on wave riding and paddling (Farley et al., 2016; Forsyth et al., 2017; Minahan et al., 2016; Moreira et al., 2014; Secomb et al., 2015b; Sinclair et al., 2017), being the pop-up often overlooked despite recognised as an important aspect of surfing. As surfing has gained worldwide popularity in recent years, there has been a parallel increase in sport sciences attempting to maximise sports performance (Anthony et al., 2016b). Success at any level within surfing requires a high level of skill execution and technical ability (Lowdon, 1983). Detailed knowledge of the technique and the physical demands required to proper pop-up are important for preventing injuries, effective coaching, and improving performance. Studies examining full-body motion and both upper and lower extremity force during the pop-up are therefore both necessary and lacking.

Previous studies have also identified that certain body characteristics may influence an individual's performance while surfing (Fernandez-Gamboa et al., 2017). For example, findings related to levels of body fat mass (Barlow et al., 2012) and height of the centre of gravity (Hayes, 1982) demonstrate, respectively, an inverse relationship to the ability to paddle and with stability. It is therefore likely that anthropometric factors may impact the performance of the pop-up, yet to date, this has not been investigated.

The purpose of this study was to describe kinematics and ground reaction force parameters of surfers performing a simulated pop-up movement. In addition, regular and goofy foot surfers were compared, as were measurements of select anthropometric properties, in order to determine whether any of these factors are associated with the performance of a simulated pop-up movement.

Methods

This is an exploratory and descriptive study using anthropometrical measurements, followed by a three-dimensional motion capture, synchronized with ground reaction forces taken from multiple force platforms in laboratory standardised conditions. The combination of the techniques allowed for a complete, whole-body, biomechanical analysis of the pop-up motion. This study was approved by the local Ethics Committee (Project number: CEFAD 27.2014).

Participants

Twenty-three male surfers (age: 28.4 ± 10.1 years old; body mass: 68.3 ± 10.8 kg; height: 1.73 ± 0.07 m; time of practice: 12.4 ± 8.9 years; arm-span: 1.75 ± 8.9 m) volunteered to take part in this study. As an inclusion criterion, participants had surfed for at least 2 years with a minimum regular practice of once a week. Exclusion criteria reject any serious musculoskeletal injuries in the last 6 months. Table 5-1 shows the participants cross information about hands-dominance and feet's base.

Table 5-1. Cross information among *surfer's*, hand's dominance and stance feet base.

| Hand's Dominance | Stance Feet Base | | Total |
|------------------|------------------|-------|-------|
| | Regular | Goofy | |
| Right | 10 | 7 | 17 |
| Left | 2 | 4 | 6 |
| Total | 12 | 11 | 23 |

Experimental Procedures

Prior to the pop-up analysis, surfers' anthropometric measurements and body composition analysis were obtained, both while in the standing position. Body composition was assessed through multifrequency bio-impedance analysis using the InBody 230 (Biospace Co., Ltd., Seoul, Korea). Together, these tests yielded body mass index (BMI), percentage of skeletal muscle mass (SMM%), percentage of body fat mass (BFM%), and waist to hip ratio (WHR).

A 12 camera digital motion capture system (mocap) (Qualisys, Gothenburg, Sweden) was used to record 3 dimensional movement of the participants at 200 Hz. A volume of approximately 45 m³ (5 m long, 3 m wide and 3 m deep) was calibrated using an L-shaped reference structure and wand according to manufacturer's recommendations (0.7 mm standard deviation error calibration mean). Spherical retro-reflective markers were attached to the skin by double-faced adhesive tape, and clusters were fastened with an elastic strap. The full-body marker model consisted of 48 markers (figure 5-1).

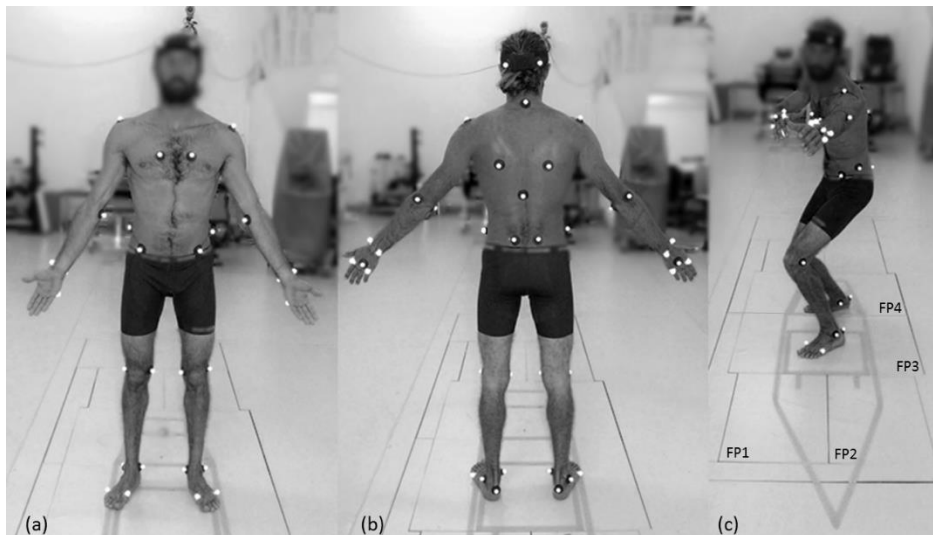

Figure 5-1. Full-body markers setup: (a) anterior view; (b) posterior view; (c) force plates arrangement and surfboard drawing representation.

Ground reaction force data were obtained using four force plates (figure 5-1c). Two of the force plates FP1 and FP2, were 60 x 40 cm; and the other two

FP3 and FP4, were 60 x 90 cm (Bertec, Columbus, USA). The force plates were mounted flush with the laboratory floor, and ground reaction force data were acquired at 1000 Hz. The two-dimensional outline of a typical short surfboard (6 foot 2 inches in length) was created on the laboratory floor using tape. The image was constructed such that each of the four force plates were positioned in a quadrant of the board and could register the force generated by each upper and lower limb in action during the pop-up motion.

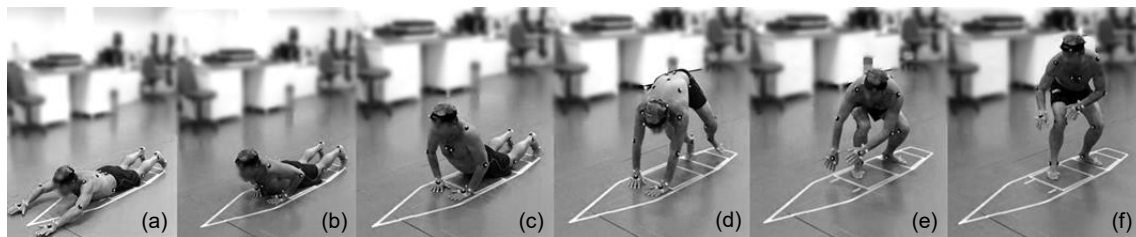

Figure 5-2. The sequence of movements performed: (a) paddle simulation, (b) touch hands on the surfboard, (c) pushing, (d) transition, (e) reaching the surfboard and (f) weight stabilisation.

The surfers were instructed to familiarise themselves with the representative surfboard and force plates and to adjust their prone position according to their personal preferences. The researcher then explained the procedures for simulating the pop-up movement freely, while respecting the surfboard dimensions on the floor. First, the surfers were asked to simulate 3-4 paddling movements, followed by placement of their hands on the surfboard as they might while performing the pop-up. At this moment, the recommendation was to approach the surfboard with both hands on the FP1 and FP2 (figure 5-2.b-d). If surfers did not follow this procedure, adjustments were made by asking the surfer to move fore or aft along the surfboard. Following this familiarisation period, surfers were allowed to perform the entire pop-up motion freely, without any restriction from the researcher (figure 5-2).

Data Processing and Analysis

Qualisys Track Manager – QTM Version 2.2 (Qualisys, Gothenburg, Sweden) software was used to acquire the 3D kinematic data, synchronised with

the force plates. Each reflective track marker was identified using the respective anatomical reference label. The marker reconstruction accuracy reached 100%. After this treatment, the data files were exported using a public domain binary file format, C3D (Coordinate 3D – C3D.org), which stores 3D data and their associated parameters (i.e., 3D ground reaction forces) in a single file.

Visual 3D Professional version 6.0 (C-motion Inc., Rockville, MD, USA) software was used to process the kinematic and ground reaction force data from the C3D files. A full-body biomechanical model was created according to recommendations from C-motion Visual3D documentation and applied in each file, taking into account each surfer's body weight.

The beginning of the pop-up was considered when at least one hand touched the surfboard (FP1 or FP2), right after the simulated sprint paddling. Thereafter, the data mining process and visual inspection of the motion technique analysis reveal 3 distinct serial and complementary phases: (i) The push-up phase is defined as the time between first-hand contact with the surfboard, followed by the push-up movement, up to the point when both hands leave the surfboard; (ii) The transition phase can be performed in two distinct ways: 1) Wipe-transition – the surfer experiences a flight phase (no contact) or immediately after their hands leave the surfboard one or both of their feet contacts the surfboard – the duration counts the time between hands leave the surfboard until any foot touch the surfboard; 2) Overlap-transition – the surfers' hands remain in contact with the surfboard while one or both feet contact the surfboard – the duration starts to count when any foot touch the surfboard until both hands leave the surfboard; (iii) The reaching phase refers to the period between either foot touching the surfboard and the surfer achieving stabilization of their own weight on the surfboard. The stabilization of the weight was defined as the instant wherein the surfers reached their exact body weight, measured by FP3 and FP4. The reaching phase should result in the surfers' feet individually positioned front foot on FP3 and back foot on FP4 (figure 5-1.c and 5-2.f). If this did not happen, the surfer repeated the action, making adjustments until his technique produced the desired motion. The stabilization time defines the end of the pop-up movement.

A specific pipeline script command for Visual 3D was created to identify events that define the pop-up phases, and to extract the related parameters to be analysed. The principal time-related events and parameters were: a) hands touch FP1 and FP2; b) distance between hands using the lateral markers positioned in the *metacarpus* of the little fingers; c) pushing-up peak-force resulting of FP1-2, and the respective elbows angles in this instant; d) instant when the hands leave FP1-2; e) feet touched FP3-4; f) reaching peak-force resulting from FP3-4 and the respective knees angles and g) weight stabilization and the feet base distance (using the lateral markers positioned on the *metatarsus* of the 5th toes). Events that were not automatically detected were created manually. All the events registered were visually inspected. Data processing generated outputs in text files for statistical analysis.

Statistical Analysis

All data were analysed using the statistical software Statistica 12 (StatSoft®, Tulsa, USA) and Excel 2016 - (Microsoft Corp., Redmond, USA) with $p \leq 0.05$ significance level. All variables were reported with descriptive statistics (mean and standard deviation). The ground reaction force values in individual time curves were normalized by individual body weight (N/ Weight). To calculate the impulse and impact absorption during each phase, the time integral of the force/time curves were calculated. A significance level (α) of 0.05 was used for the inferential tests. Factorial-ANOVA was used to investigate differences in kinematic parameters (elbows and knees angles during the peak-forces) between hand-dominance and stance-feet-base. A one-way ANOVA was conducted to verify the existence of differences between the type of transition and the performance of the pop-up. Dependent-samples t-test was used to identify differences between individual hand peak-forces during the push-up phase, and also for the reaching phase comparing front and rear feet peak-force distribution. A Multiple Linear Regression was applied to analyse the influence of body characteristics (SMM%, BFM%, height) on the performance of the pop-up technique.

Results

Kinematics

Factorial ANOVA was used to analyse possible differences in kinematic parameters between hand-dominance and stance-feet-base. No interaction effect, $F(1,19) = 0.044$; $p = 0.83$, or main effects were found: hand-dominance $F(1,21) = 0.121$; $p = 0.73$, and the stance-feet-base $F(1,21) = 0.633$; $p = 0.435$. Further, no differences in elbow angles were detected during the peak-force on the push-up phase between the dominant and non-dominant hands ($110 \pm 18^\circ$ vs $112 \pm 18^\circ$). Finally, no differences in knee angles were observed during the peak-force on the reaching phase between the front and back foot ($99 \pm 20^\circ$ vs $101 \pm 14^\circ$). In this way, all the kinematic results for right or left-hand dominance, and regular or goofy stance feet base were reported without distinction for these criteria.

The entire pop-up movement (figure 5-3) showed an average duration of 1.20 ± 0.19 s. Deconstructing the technique into elementary parts, $61 \pm 10\%$ (0.71 ± 0.08 s) of the time was spent in the push-up phase; $0 \pm 8\%$ (0 ± 0.09 s) in the transition phase; and $39 \pm 13\%$ (0.48 ± 0.22 s) in the reaching phase. During the transition phase, 57% of the surfers used the wipe-transition (brief flight phase), while 43% used the overlap transition. No differences were found, $F(1, 21) = 0.02$; $p = 0.87$, related to the total pop-up execution time between these two variations in technique.

Ground Reaction Force

During the push-up phase, the hands-base width was 0.46 ± 0.05 m and achieved a relative total peak-force of 0.99 ± 0.10 N/Weight. The non-dominant hand exerted significantly greater peak-forces during the push-up phase, on average, than the dominant hand ($52 \pm 4\%$ vs. $48 \pm 4\%$, respectively, $t(22) = -2.27$; $p = 0.03$). However, the entire force/time curve was equally distributed for both hands ($50\% \pm 5\%$ each), with similar impulses, $t(22) = -1.36$; $p = 0.18$, of 0.30 ± 0.05 N.s/Weight, for the dominant hand, and 0.29 ± 0.07 N.s/Weight for the non-dominant hand.

During the reaching phase, the surfers positioned their feet 0.63 ± 0.10 m apart, and generated a peak 1.63 ± 18 N/Weight of impact force. The landing peak-force distribution between feet showed significant differences, $t(22) = -2.76$; $p = 0.01$; where $39 \pm 19\%$ occurred in the rear foot and $61\% \pm 19\%$ occurred in the front foot. The entire force/time curve distribution reinforced this difference, $t(22) = 13.09$; $p < 0.01$, where $28 \pm 8\%$ occurred in the rear foot and $72\% \pm 8\%$ occurred in the front foot, with the respective impact absorption of 0.32 ± 0.11 N.s/Weight, and 0.81 ± 0.13 N.s/Weight.

Anthropometry

On average, participants demonstrated body composition values as follows: BMI 23 ± 3 ; SMM% $49 \pm 3\%$; BFM% $14 \pm 5\%$, and WHR 0.84 ± 0.05 . An inverse relationship between SMM% and the transition phase time was found, $r = -0.50$; $p = 0.01$; and the same for feet-base and the rear-knee angle $r = -0.50$; $p = 0.01$. No correlations were found for pop-up velocity performance versus body characteristics: SMM% ($r = 0.15$; $p = 0.47$), BFM% ($r = 0.05$; $p = 0.81$), and height ($r = 0.09$; $p = 0.67$). No significant regression weights were found after controlling for each variable, $R^2 = 0.15$; $F(3, 19) = 1.12$; $p < 0.36$.

Discussion

The purpose of this study was to analyse the kinematics and kinetics of pop-up movement during simulated conditions, using a specially designed configuration of force plates representing a typical surfboard. This configuration allowed for decoupling the entire ground reaction forces into an individual analysis of each body limb contribution, associated with 3D kinematic information from the mocap system. These data were then used to characterize critical aspects of the pop-up technique from a full-body-model biomechanical perspective.

There were four primary results from this study. First, no differences in upper and lower body kinematics were observed between the dominant vs. non-dominant hands, or among surfers who preferred a regular vs. goofy foot stance.

Second, ground reaction peak-force generated by the hands during the push-up phase were different and greater for the non-dominant hand. However, while analysing the impulse over the entire duration of the phase, the force profiles between hands were very similar and symmetric. Third, ground reaction forces generated by the lower extremities during the reaching phase were significantly different, with the front foot applying greater force than that of the rear foot. Finally, a significant inverse relationship was found between skeletal muscle mass percentage and total duration of the pop-up ($r=-0.50$; $p=0.01$), but no other relationships were found between anthropometric variables and performance. Additional results included the observation of two distinct pop-up techniques utilized by participants, defined by either the presence (57% of participants) or absence (43% of participants) of a brief flight phase.

Push-up Phase

The pop-up technique is very fast and involves a coordinated sequence of movements that start with strength and powerful push-up phase (Mendez-Villanueva et al., 2005a). According to our data, the surfers pushed, using the hands alone, with a total force equal to their full-body weight. Though a relatively small difference was detected in peak-force between the two hands, the full time-force curve for the push-up phase was very similar. A similar force distribution between hands may contribute to improved balance for the pop-up execution, preventing unwanted instability of the surfboard on the water surface. Our results demonstrate that the relative push peak-force was slightly higher than that reported by Eurich et al. (2010), who reported 0.95 N/Weight for men and 0.81 N/Weight for women. The inclusion of impulse values appears to be helpful in understanding the work involved in this explosive task.

Transition Phase

Surfers in this study used one of two distinct techniques during the transition phase, as they shifted their body from the horizontal to the vertical standing position. These observed transition types included the wipe and overlap

techniques (figure 5-4.). The data indicated that using either technique did not result in any differences in the velocity of the entire pop-up motion. Conversely, an inverse correlation was found between SMM% and the transition phase duration. This suggests that surfers with higher muscular mass can perform the transition phase faster, and may have greater control of the type of transition used. However, when one considers the dynamic and unstable environment in which the pop-up is executed, it may be advantageous for the surfer to maintain contact with the board at all times.

Reaching Phase

When surfers placed their feet on the simulated surfboard, the maximal load reached approximately 160% of their body weight. While this value may appear high, it is important to note that this was recorded in a laboratory environment; these values may be different in the water, depending on the type of board and oceanic conditions. During the landing phase of the simulated pop-up, the distribution of the load, unlike the push-up phase, was quite uneven. This difference may be a consequence of the unstable conditions experienced by the surfer in water. In particular, applying a greater relative force with the front foot will help to reduce the pitch angle of the board and keep it flat against the surface of the water. This action would help to increase the drop velocity and keep the surfer's body perpendicular to the surfboard, possibly leading to more balance and control of the surfboard through of their feet. It may also help to propel the surfer's centre of mass down the slope of the wave.

On the other hand, more weight on the rear foot would serve to increase the pitch angle, thereby increasing the drag resistance, and slowing down the surfboard velocity. It is interesting to note that most participants applied a greater percentage of body weight on their front foot (about 60%). This suggests that front-aft distribution of weight during the reaching phase may be an important factor in increasing the drop velocity while riding a wave.

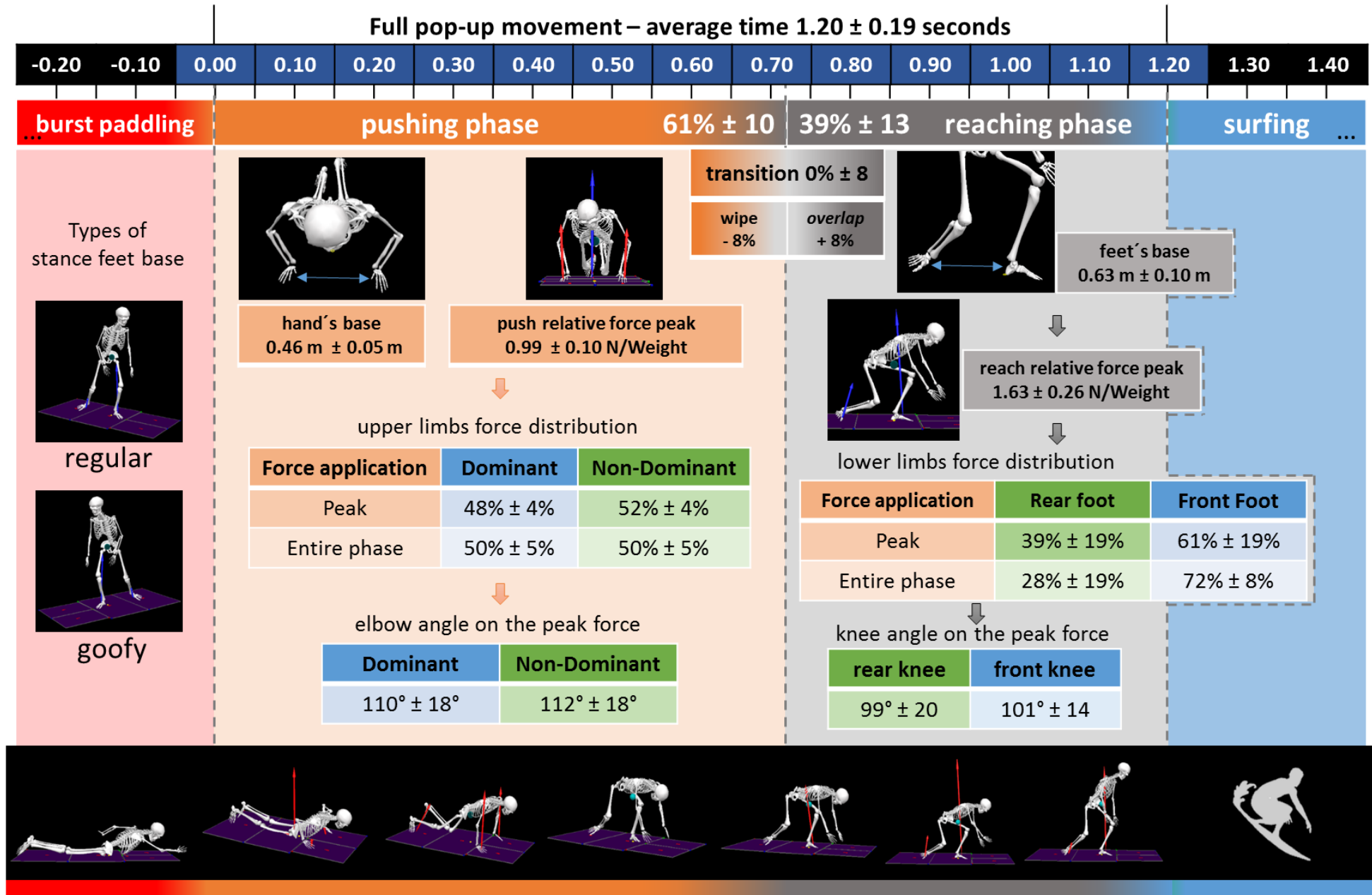
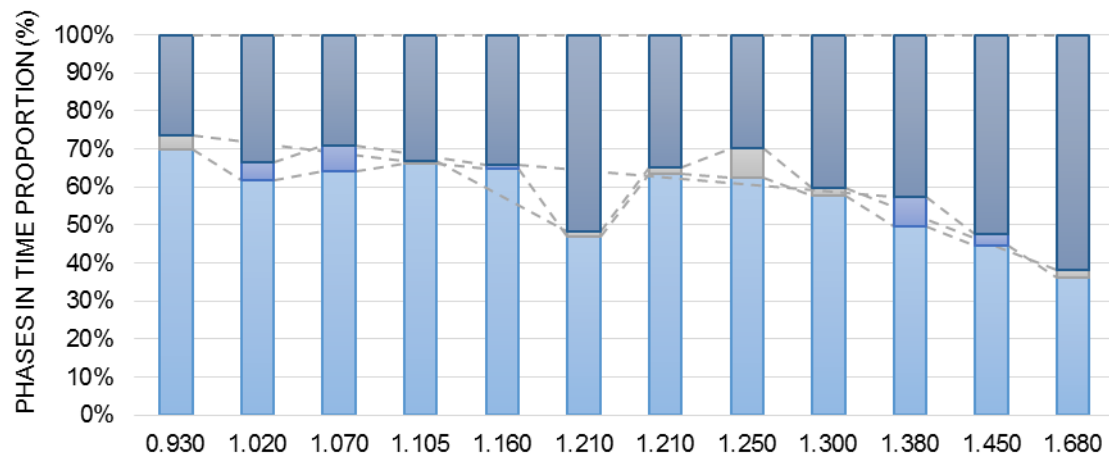

Figure 5-3. Infographic of pop-up movement results.

Regular stance base



Goofy stance base

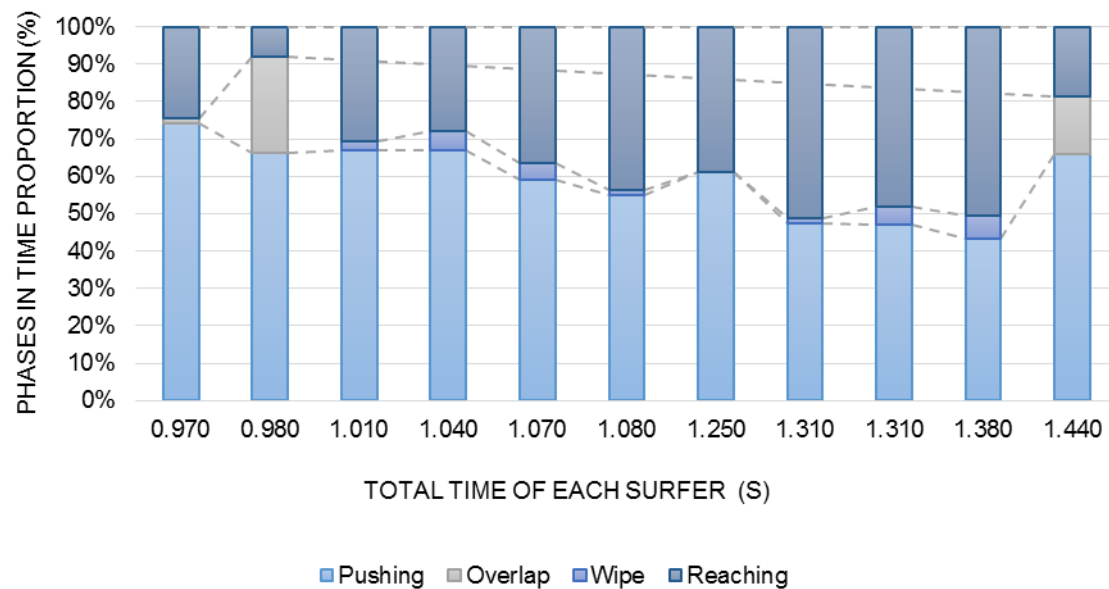

Figure 5-4. Individual phases proportion of the pop-up movement and different transitions technique to achieve the stabilized standing position.

The stance of a surfer is described as a half-squat position with knees flexed 30-80°, with the rear knee in a valgus position (Everline, 2007). The current results generally support this description but overall showed higher knee flexion angles and a lack of consistency among surfers regarding foot placement. Also, foot placement did not appear to be related to any variable that was analysed here. It is speculated that the feet base length chosen by the surfers could be

related to the surfboard size and/or to the surfer's comfort in the standing position. In this position, the rear and front knee angles showed similar values in magnitude, but indeed, the legs were positioned differently. Accordingly, the rear leg showed slight internal rotation, a pronated foot and the knee pointing to the middle of the surfboard, while the front leg held a normal squat position. With this description, it is easier to understand the observed relevant correlation between the feet base and the rear knee angle. The closer the feet are, the lower the knee angle should be, in the way to compensate the shorter distance.

Limitations

This work characterises a simulated pop-up movement, performed by surfers as they shift from horizontal to the standing position on the laboratory floor, which may be somewhat different from performing a similar motion in the ocean. In particular, the breaking wave generates greater challenges, and the relevance of these ecological differences cannot be estimated. In addition, the simulated test utilised a stationary paradigm, which is different from the dynamic and changeable conditions created by the waves. However, limitations in equipment have precluded testing in the ocean, and the analyses described here were performed under highly controlled and repeatable conditions, which are very difficult to achieve in the ocean. Further, the pop-up movements explored in this study were, apparently, very similar to those performed while surfing. In all, these methods provide useful and applicable information for understanding pop-up technique performance across surfers.

Conclusion

A simulated pop-up motion performed by surfers in the laboratory was analysed using motion capture and specially configured force platforms. The pop-up was characterised by three sequential phases: push-up, transition, and reaching. During the push-up phase, the upper limbs acted symmetrically and generated forces equivalent to full-body weight in order to initiate the change from

a prone to standing position. During the transition phase, approximately 57% of participants exhibited a brief flight phase, whereas 43% maintained contact with the simulated board throughout the entire motion. During the reaching phase, the front lower limb applied greater force to the board, presumably to maintain a lower pitch angle and reduce drag force as the surfer accelerates down the wave and begins to manoeuvre. These data provide biomechanical insight to this motion and may be applicable to training and coaching surfing athletes as they seek to improve their surfing performance by focusing on their pop-up technique.

Chapter 5

Energetic profile of a surfing paddling cycle

Márcio Borgonovo-Santos^{1,2,3,4}, Rodrigo Zacca^{1,2,3}, Ricardo Fernandes^{1,2}, João Paulo Vilas-Boas^{1,2}.

¹ Centre of Research, Education, Innovation and Intervention in Sport, Faculty of Sport, University of Porto, Porto, Portugal

² Porto Biomechanics Laboratory, University of Porto, Porto, Portugal

³ CAPES Foundation, Ministry of Education of Brazil, Brasília, Brazil

⁴ Surfing Viana High Performance Centre – Surf Club Viana, Viana do Castelo, Portugal.

Abstract

Modern surfing is described as short intermittent exercise, which varies in duration and intensity, followed by considerable recovery periods. In this way, our study aimed to bioenergetically characterise a cycle of surf paddlings, and compare the sprint-paddling performance interposed by endurance-paddling. Sixteen male surfers (23.5 ± 10.0 years old; 65.3 ± 11.4 kg; 1.72 ± 0.01 m) volunteered to take part in this study. Two sessions of tethered-paddling and sprint-paddling (10 s each), interposed by endurance paddling (6 min), were evaluated. No significant differences were observed for tethered-paddling force and sprint-paddling velocity when pre and post-endurance-paddling were compared. For the endurance-paddling, the Heart Rate (HR) ranged from $74 \pm 12\%$ HRmax in the first minute up to $88 \pm 9\%$ HRmax in the last minute. The $\dot{V}O_2$ kinetics showed a bi-exponential curve behaviour with a fast and slow component, and a total energetic expenditure (E_{tot}) of 300.5 ± 60.5 kJ, metabolic power (\dot{E}) of 0.83 ± 0.16 kW and energetic cost (C) of 0.72 ± 0.16 kJ·m⁻¹. The lactate curve of all tests showed linear growing until the endurance-paddling test ($p < 0.01$), and after that the values stabilized. Our results demonstrated the use of multi-energy sources during a surf session, and the specificity of each type of paddling addressed to different participation of energy pathways, even analysing just the paddling intensities and durations. These findings could help in the understanding of the energetic demands in surfing.

Keywords: surf energetic demands, paddling, ecological, surf fluid dynamics.

Introduction

Modern surfing is described as intermittent exercise, which varies in duration and intensity, followed by considerable recovery periods (Mendez-Villanueva et al. 2005). The duration of a surf session usually ranges from 20 min (during a competition event) to 4 to 5 h during training sessions. However, during excellent swell conditions, free-surfers could endure even 7 h of practice within three sessions a day (Frank et al., 2009; Lowdon et al., 1989; Meir et al., 1991; Mendez-Villanueva et al., 2005a).

Despite that, the proportion of the activities is relatively consistent in competition (Farley et al., 2012; Mendez-Villanueva et al., 2006), training (Secomb et al., 2015) or even recreational practice (Meir et al., 1991). Typically, surfers devote ~50% of their time paddling, ~40% stationary and resting, ~3% wave riding, and ~7% with miscellaneous (e.g., recovering the surfboard). Moreover, the paddling action can be even more detailed (Secomb et al., 2015): a) ~21% paddling to return to the line-up, (mean duration of 63.8 s); b) ~4% sprint-paddling to the wave (mean duration of 6.3 s), and c) ~18% general paddling (mean duration of 14.5 s).

In average, surfers cover distances greater than 1800 m in a single competition's heat, where 60% of the total time is performed between 56 to 74% of maximal heart rate (Farley et al., 2012). These energetic demands in surfing require highly developed anaerobic and aerobic systems (Minahan et al., 2016). A well-trained oxygen transport system is beneficial to maintain a high physical performance and to accelerate the recovery processes, throughout extended periods of intermittent high intensity (Tomlin et al., 2001). This kind of energetic profile is well studied in swimming, providing relevant insights and can be used with surfers (Sousa et al., 2015; Zacca et al., 2018). The maximal attainable swimming speed is given by the ratio between net metabolic power (\dot{E}) and the energy cost to swim a unit distance (C). Aerobic (Aer), anaerobic lactic (AnL) and alactic (AnAL) energy contributions to \dot{E} depend on the duration of the exercise (di Prampero, 1986). Any influence on hydrodynamic resistance and/or propelling

efficiency leads to proportional changes in C (Sousa et al., 2013; Zamparo et al., 2011).

Scientific efforts to improve the knowledge about the energetic demands in surfing are evident (Ekmeçic et al., 2017; Furness et al., 2018; Minahan et al., 2016). However, the integrated assessment of endurance and power paddling during a surfing session cycle is scarce. This gap is even greater when considering studies with an ecological perspective, i.e. in the aquatic environment. Surfing paddling technique is highly specific, and out-of-water simulation (i.e., land ergometers) seems to be far from the real movement (Araújo et al., 2007). An evaluation in ecological environment could provide deeper insights about energetic profile in surfing. The interaction between energy systems and biomechanical parameters from sprint and endurance paddling could guide sports scientists and coaches, thus improving training methods and planning strategies. This study aimed to perform an integrated analysis, characterizing the biomechanical and energetic profile of sprint- and endurance-paddling periods from a single surfing paddling's cycle.

Methods

This study has an exploratory and descriptive design. Specific functional tests were applied, simulating the combination of intermittent paddling actions observed during one surf session cycle. The figure 6-1 shows the main activities performed during a surf session, more specifically, the paddling, pop-up and manoeuvres. Furthermore, we developed a schematic organisation about the energy profile of a surf session, which guided this research.

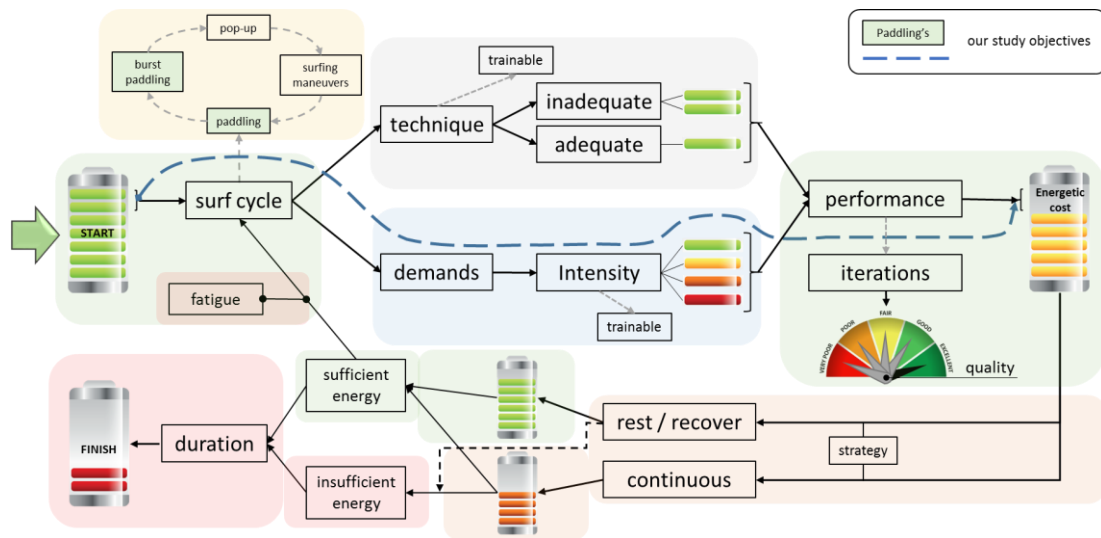

Figure 6-1. Rationale of the research showing a model of a surf session energetic profile and our goal line.

Participants

Sixteen male surfers (age: 23.5 ± 10.0 years old; body mass: 65.3 ± 11.4 kg; height: 1.72 ± 0.01 m; time of practice: 9.1 ± 8.9 years; arm-span: 1.75 ± 11.4 m) volunteered to take part in this study. As an inclusion criterion, participants had surfed for at least 2 years with a minimum regular practice of once a week. Exclusion criteria reject any serious musculoskeletal injuries in the last 6 months.

Experimental Procedures

The local Ethics Committee approved the research procedures. Before the tests, the surfers were submitted to anthropometric and body composition evaluation, examined in the standing position. Body composition assessment was performed through a multifrequency bio-impedance analysis (InBody 230, Biospace Co., Ltd., Seoul, Korea). The body composition tests included body mass index (BMI), percentage of skeletal muscle mass (SMM%), percentage of body fat mass (BFM%), and waist to hip ratio (WHR).

The tests took place in a 25 m indoor swimming pool (27°C of water and 26°C air temperature with 70% of humidity), and the surfers used their own surfboards, minimising constraints and thus simulating surfing environment. The warm-up consisted of self-stretching exercises; 3 min light-intensity continuous

paddling, followed by 30 s rest and 2 x 15 m maximal-intensity paddling efforts, followed by a 10 min rest.

The sequence of functional paddling tests (figure 6-2) was respectively: tethered-paddling; sprint-paddling; endurance-paddling; sprint-paddling; tethered-paddling; three minutes of rest intervals were conducted between each step. Blood lactate samples were collected during rest and at the end of each step.

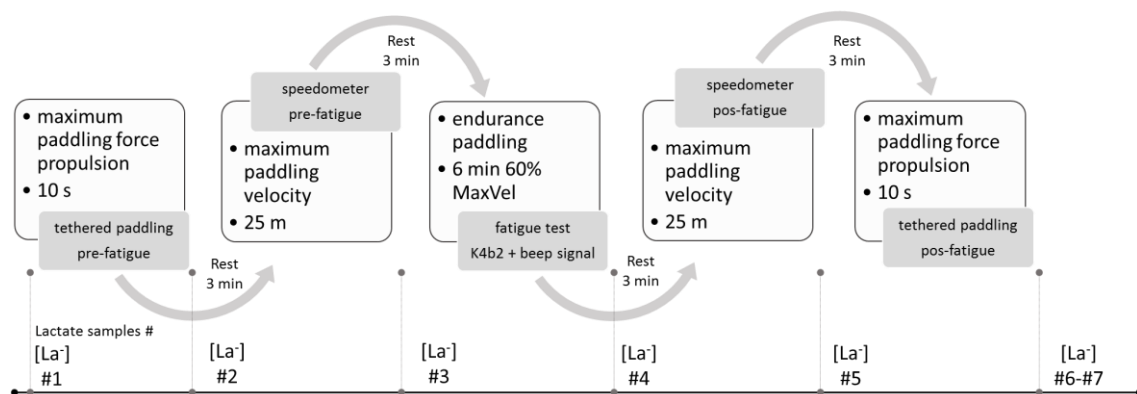

Figure 6-2. A general overview of the tests applied, the sequence of execution and lactate samples.

Surf Paddling Propulsion

After the warm-up and rest period, the tethered-paddling test was performed (figure 6-3a). A belt was attached around the lumbar-sacral area, connected to a 5 m length non-elastic steel cable, coupled to a load cell fixed on the pool wall (Morouço et al., 2012). Immediately before the starting signal, surfers adopted a horizontal position on the surfboard with the cable fully extended. Data collection began when the first paddle cycle was completed, avoiding the inertial effect of the cable extension, usually observed immediately before or during the first arm action (Morouço et al., 2012). According to the surf time-motion analysis (Secomb et al., 2015b), the sprint paddling duration round 6 s. In order to ensure this time for our analysis, each participant performed the tethered-surf-paddling at all-out intensity for a period of 10 s (Loveless et al., 2010b). The test ends with an acoustic signal.

A load cell system (5000 N, Globus, Italy) was used to measure force parameters, recording at 100 Hz, and connected to an analogic/digital data acquisition system Biopac MP150 (Biopac®, USA) with the software Acknowledge v4.0. All data recorded were smoothed with a digital low-pass filter with 10Hz cut-off frequency to remove noise and artefacts of movement. The calibration was performed with the curve provided by the manufacturer.

Maximal Paddling Velocity

After an interval of 3 min, the 20 m all-out velocity test (figure 6-3d) was performed. Surfers assumed a prone paddling position on their surfboard, without contact with the pool wall. Following the start signal, surfers paddled freely across the pool with maximum intensity. Velocity was recorded using a cable-based speedometer device (Lima, 2006). This instrument uses a bobbin with a non-elastic line that is fixed to the surfer's clothing with a clip in the middle of the lumbar region. The speedometer was placed on the pool wall, about 0.3 m above the water surface. Continuous velocity data were obtained during the course of 25 meters, at a 50 Hz frequency, exported to the software Acknowledge v4.0, and filtered with a 15 Hz cut-off digital filter (FIR - Window Blackman -61dB). The cut-off value was selected based upon FFT analysis to minimize artefact noise. The velocity variables obtained in individual velocity-time curves were: Peak Velocity and Mean Velocity every two seconds.

Endurance Paddling

A recent study (Secomb et al., 2015b) identified patterns of paddling during a surf training session ranging from as much as 10 s, and greater than 90 s. Regarding the intensity, the mean velocity reported for the surfer's endurance paddling (Coyne et al., 2017; Farley et al., 2016) ranges from 64% to 70% of the maximal velocity.

The six minutes time-duration was selected based on well-established literature (Enright, 2003) for a walking endurance test, easier to administer, better tolerated. Relatively, the walking exercise on land is equivalent to paddling action

on the water locomotion. To ensure that surfers complete the test with intermediary intensity effort, and access aerobic energetic pathways, the endurance paddling protocol was defined with six minutes of paddling at 60% of the peak velocity obtained in the maximal paddling velocity test.

To perform this test, two cones 20 m apart, were placed on the edge of the pool as a reference for the surfers. A beep was triggered to set the pace – the relation between the distance (20 m) and velocity (60% of maximal) was calculated for each participant and defined the frequency of the pacer signal during six minutes to assure constant velocity.

The second trial of the tethered-paddling and maximal velocity were performed after the endurance test using the same described procedures. During all tests, surfers received verbal encouragement to be motivated and bring the best performance.

Gas Exchange and Heart Rate

During the endurance test (figure 6-3c), Respiratory and pulmonary gas-exchange data were measured breath-by-breath using a telemetric portable gas analyzer (K4b², Cosmed, Rome, Italy) connected to a respiratory snorkel and valve system AquaTrainer®, Cosmed, Rome, Italy (Baldari et al., 2013). The telemetric portable gas analyser was calibrated before each testing session and transported along the swimming pool suspended at a 2 m height over the water on a steel cable (de Jesus et al., 2014). The gas analysers were calibrated before each test with gases of known concentration (16% O₂, 5% CO₂) and the turbine volume transducer was calibrated using a 3 L syringe according to the manufacturer's instructions. Heart rate (HR) was monitored continuously by a Polar Vantage NV (Polar Electro Oy, Kempele, Finland) that transmitted the data telemetrically to the K4b² portable unit. The percentage of maximum heart rate (%HR_{max}) was calculated (Karvonen et al., 1988) to evaluate the endurance paddling HR profile.

Blood Lactate

The blood lactate [La⁻] was analysed with the equipment Lactate Pro (Arkay Inc., Kyoto, Japan), following the manufacturer's instructions. Capillary blood samples were collected from the earlobe at the resting period, immediately after the end of each protocol step, and during the final recovery period at the 1st minute, and in the 3rd minute if the values still increase (figure 6-2 and 6-3b).

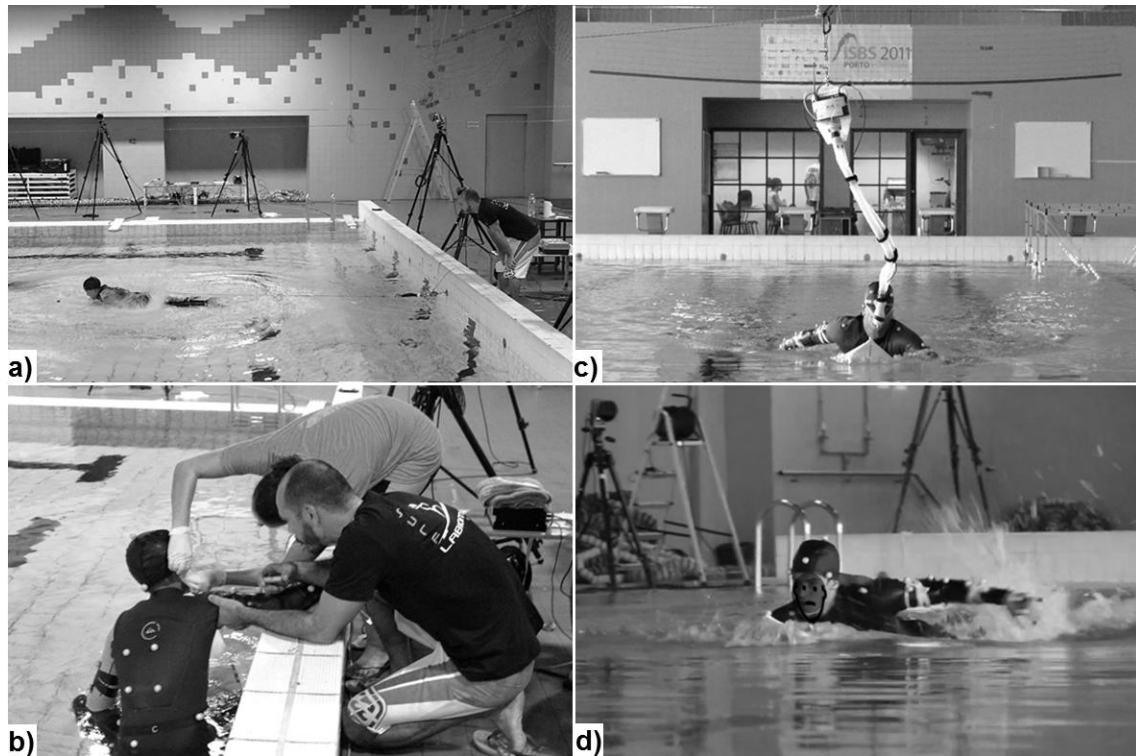

Figure 6-3. Tests on the swimming pool: a) tethered paddling; b) lactate sampling; c) endurance test with oximetry and heart rate monitor; d) maximal velocity test.

Gas Exchange Data Analysis

The first 20 s of data after the onset of exercise (cardio-dynamic phase) were not considered for $\dot{V}O_2$ kinetics analysis. For each surfer, the on-transient was modelled with a bi-exponential model (Equation 6-1), characterising the exercise $\dot{V}O_2$ response during the endurance paddling test:

$$\dot{V}O_2(t) = A_0 + H(t - TD_p) \times A_p (1 - e^{-(t - TD_p)/T_p}) + H(t - TD_{sc}) \times A_{sc} (1 - e^{-(t - TD_{sc})/T_{sc}}) \quad (5-1)$$

Where $\dot{V}O_2(t)$ ($\text{mL} \cdot \text{kg}^{-1} \cdot \text{min}^{-1}$) represents the relative $\dot{V}O_2$ at the time t , A_0 is the $\dot{V}O_2$ at rest (2 min average; $\text{mL} \cdot \text{kg}^{-1} \cdot \text{min}^{-1}$). A_{fc} and A_{sc} ($\text{mL} \cdot \text{kg}^{-1} \cdot \text{min}^{-1}$), TD_{fc} and TD_{sc} (s), are respectively the amplitudes and time delays of the fast and

slow $\dot{V}O_2$ components. H represents the Heaviside step function (Ma et al., 2010). $\dot{V}O_2$ at the end was calculated as the average of the last 60 s of exercise for both models. Since the asymptotic value of the second function is not necessarily reached at the end of the exercise, the amplitude of the A_{sc} at the end of the endurance paddling was also calculated (Equation 6-2) (Reis et al., 2017):

$$A_{sc_end} = A_{sc} (1 - e^{-(t_{end} - TD_{sc})/T_{sc}}) \quad (5-2)$$

Where t_{end} is the time at the end of the endurance paddling (6 min). The $\dot{V}O_2$ response from bi-exponential function was fitted by a routine based on nonlinear least-square regression (Baty et al., 2015). Parameter estimates and goodness of were only analysed with raw data. The software R (R Core Team) was used to perform gas analysis routines.

Energetics

The total energy expenditure (E_{tot}) during tethered-paddling and sprint were calculated in kilojoules (kJ) as the sum of anaerobic Latic (AnL) and alactic (AnAl) energy pathways. The aerobic (Aer) pathway was not assumed as contributor due to the short time endured for both tests (10 s) and recovery time required between each test (3 min). Regarding endurance paddling test, the three energy pathways were considered for E_{tot} estimation (Binzoni et al., 1992; Sousa et al., 2014; Thevelein et al., 1984; Zamparo et al., 2011). The energetic cost (C) was obtained as the ratio between E_{tot} and distance, and the metabolic power \dot{E} (kW) was estimated as the ratio between E_{tot} and time (s) of each test (Zamparo et al. 2011).

Statistical Analysis

Statistical analysis was carried out using Statistica 12 software (StatSoft®, Tulsa, USA). An algorithm for identifying maximum and minimum force-time curve peaks was developed in the Excel 2013 - VBA package (Microsoft Corp., Redmond, WA). Two independent One-Way ANOVAs check differences between pre and post endurance-paddling tests. For blood lactate changes a Repeated

Measures ANOVA with Newman-Keuls *post-hoc* was used. Normality, homogeneity and sphericity were satisfied. A significance level (α) of 0.05 was used. Bootstrapping analysis with 1000 samples was used to estimate $\dot{V}O_2$ kinetics parameters and respective coefficient of variation (Perrey, 2009). Pre-tests were identified with “#1” and post-tests with “#2”.

Results

Sprint paddling: propulsion-force and velocity

No significant differences were observed for tethered-paddling force and sprint-paddling velocity when pre and post endurance-paddling were compared (Figure 6-4). Regarding the behavior of the force curves (Figure 6-4a), the decrease of the propulsive force was progressive after (post) endurance-paddling test. In relation to the velocity curves (Figure 6-4b), a greater number of surfers (44%) reached the highest velocity in the time interval of [4-6[s in the pre-test, while in the post-test the same amount (44%) reached higher values on the interval of [6-8[s.

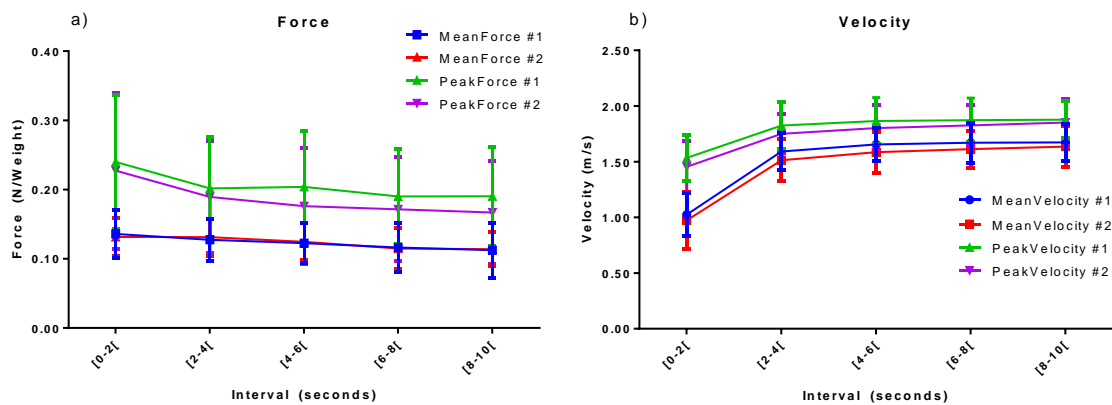

Figure 6-4. Tethered-paddling force-time performance (a) and sprint paddling velocity (b) for pre (#1) and post (#2) endurance paddling. (*) non-ordinal force reduction ($p < 0,01$).

Endurance paddling

Average distance paddled was 419 ± 38 m during 360 s (1.16 ± 0.11 m.s⁻¹). The HR ranged from 142 ± 23 bpm ($74 \pm 12\%$ HRmax) in the first minute up to 167 ± 17 bpm ($88 \pm 9\%$ HRmax) during the last minute (Figure 6-5).

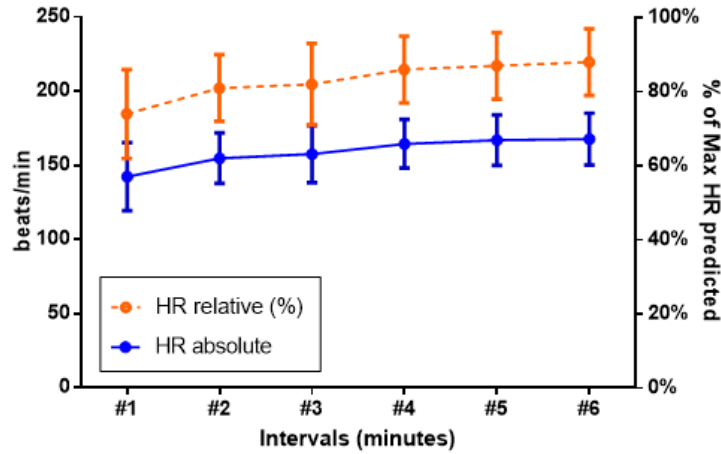

Figure 6-5. Mean values of absolute and maximum heart rate percentage during each minute of the 6 min endurance paddling at 60% of maximal velocity.

Estimated $\dot{V}O_2$ related parameters (mean \pm SD and coefficient of variation) obtained during 6 min paddling at 60% of maximal velocity can be observed in the Figure 6-6.

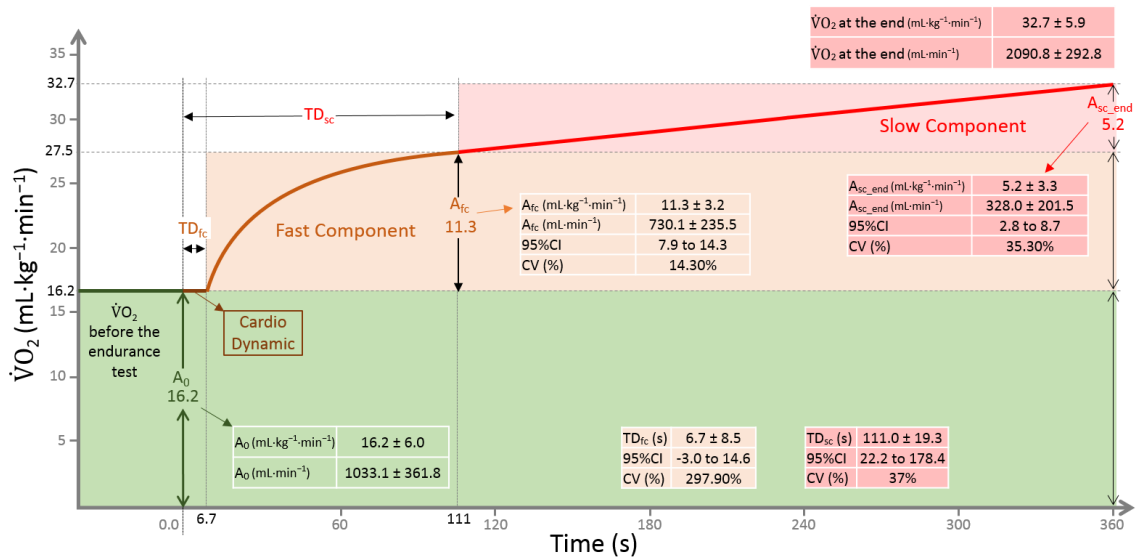

Figure 6-6. Estimated $\dot{V}O_2$ related parameters (mean \pm SD and coefficient of variation) obtained during 6 min paddling at 60% of maximal velocity. A_0 is the $\dot{V}O_2$ at before the endurance test; A_{fc} and A_{sc_end} , TD_{fc} and TD_{sc} are respectively amplitudes and corresponding time delays of the fast and slow $\dot{V}O_2$ components. The CV (%) and 95%CI are the mean coefficient of variation and 95% confidence interval for each mean parameter estimate, respectively.

Entire Protocol

Lactate Curve

The [La-] for each phase of the protocol were: Resting 1.3 ± 0.3 mmol·L⁻¹; Tethered-Paddling trial #1: 3.4 ± 1.4 mmol·L⁻¹; Sprint-Paddling trial #1: 5.4 ± 2.2 mmol·L⁻¹; Endurance-Paddling: 7.5 ± 2.8 mmol·L⁻¹; Sprint-Paddling trail #2: 7.4 ± 2.9 mmol·L⁻¹; Tethered-Paddling trial #2: 7.8 ± 2.5 mmol·L⁻¹; and after the first minute of recovery 7.8 ± 2.6 mmol·L⁻¹..

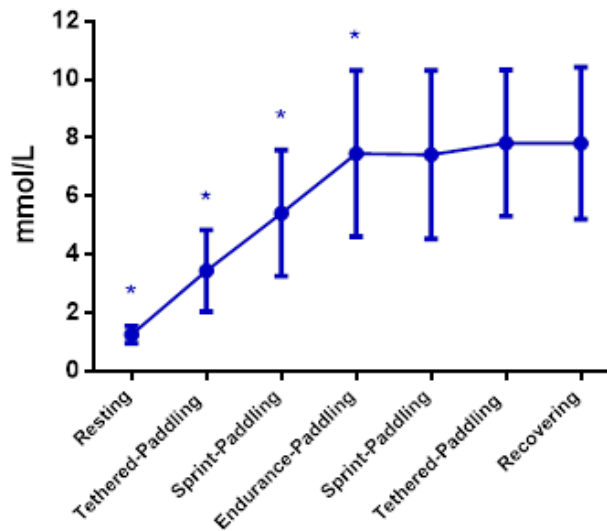

Figure 6-7. Lactate curve of the entire protocol. Differences ($p < 0.01$) were found until the endurance-paddling test, after that the values stabilize.

Significant differences were observed ($F(6, 90) = 44,426$, $p < 0,01$) between rest and each test. The *post-hoc* point the differences for all lactate samples until the endurance-paddling, after which the values stabilize.

Energetic Profile

The Figure 6-7 shows the energy pathways and respective contributions during the entire protocol. For the endurance-paddling test, a total energetic expenditure was calculated, E_{tot} of 300.5 ± 60.5 kJ, metabolic power \dot{E} of 0.83 ± 0.16 kW and energetic cost C of 0.72 ± 0.16 kJ·m⁻¹.

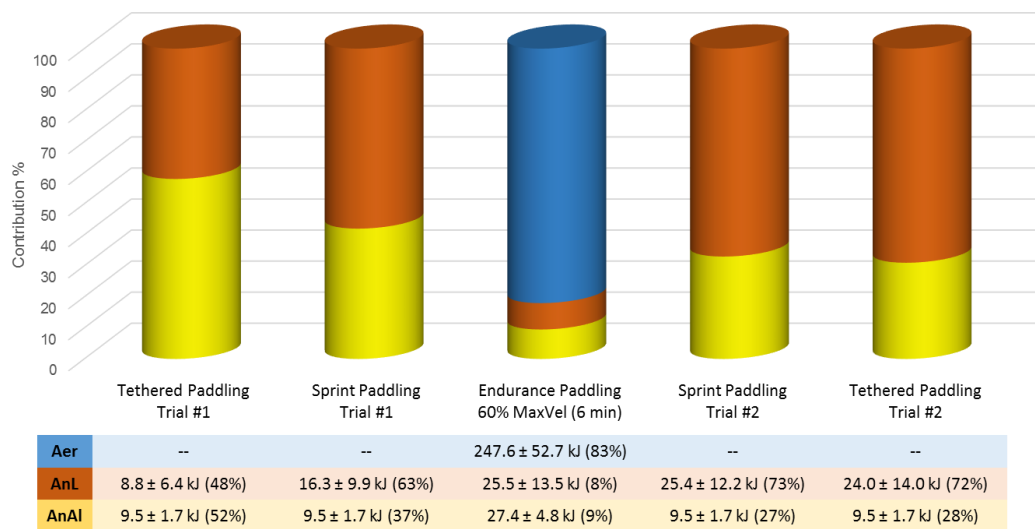

Figure 6-7. The energy pathways mean values and respective contributions (%) during the entire protocol.

Discussion

The purpose of this study was to characterise the energetic profile of a surfing paddling cycle and compare the sprint-paddling performance interposed by endurance-paddling and rest periods, particularly focusing in the parameters related with the upper limbs propulsive forces and maximal paddling velocity; All these was conducted under an ecological approach in the way to simulate real efforts on a swimming pool. Findings from the current study support our purpose, thus improving the general understanding of energy requirements to sustain the physiological and biomechanical demands during a cycle of sprint and endurance paddling in a surf session.

Sprint paddling: propulsion-force and velocity

The tethered swimming is considered a valid procedure to evaluate the swimmer's propulsion-force production, also used as a reliable estimator for swimming performance assessment (Morouço et al., 2012). Even though, the tethered paddling does not evaluate the hydrodynamic drag which the surfer and surfboard (shape and buoyancy) system must overcome. Indeed, the test allows to measure the surfer's capacity to produce force. A similar protocol in swimming (10 s maximal tethered swims) found PeakForce of 207.1 ± 27.2 N and

MeanForce of 133.2 ± 16.8 N (Loturco et al., 2016). Smaller absolute values (Figure 6-4a) were observed for surfers (PeakForce of $163.9.1 \pm 44.5$ N and MeanForce of 76.7 ± 18.7 N). These differences were expected, firstly, because of the participants' heterogeneity, regarding age and anthropometrics. Secondly, the surfboard buoyance makes only part of the arms to be immersed in the water during the propulsion phase, thus reducing the water contact area, a mechanical determinant to produce propulsion force in water surface locomotion (Lauer et al., 2016). On the other hand, the relative forces (force \div body weight) were not reported, these values respect the differences of each person weight and allow comparisons regarding the capacity to produce effective propelling-forces. Furthermore, it is possible to speculate that swimmers present a higher level of training and, consequently, force development than surfers. Thus, stronger similarities between surfers and swimmers were not expectable.

In a 25 m pool environment, it is possible to control the influences of wind, water surface and currents, common difficulties faced at sea that drastically affect the surfers' paddling performance (Everline, 2007). However, surf evaluation protocols in swimming pool respect more the ecological characteristics of movements performed by surfers into the water, when compared with evaluations performed on land ergometers. This controlled environment simplifies the calculation of surf paddling-velocity as a resultant of the propulsion-force and technique associated with the surfboard characteristics.

Several studies have implemented pool-based protocols, in which peak velocities outcomes ranged from $1.11 \text{ m}\cdot\text{s}^{-1}$ for junior practitioners to $2.04 \text{ m}\cdot\text{s}^{-1}$ in professional surfers (Farley et al., 2016; Furness et al., 2018; Loveless et al., 2010a; Minahan et al., 2016; Secomb et al., 2015; Secomb et al., 2015b; Sheppard et al., 2012c; Sheppard et al., 2013a). Our results are in agreement with these ranges (Figure 6-4b), but we also explored the effect of endurance paddling and rest intervals on the performance of sprint paddling. The similitude between our pre and post measures may be associated with the sufficient recovery time between trials. Although, the values decreased for both mean velocity (pre $1.52 \pm 0.17 \text{ m}\cdot\text{s}^{-1}$ and post $1.46 \pm 0.19 \text{ m}\cdot\text{s}^{-1}$) and peak velocity (pre $1.79 \pm 0.20 \text{ m}\cdot\text{s}^{-1}$ and post $1.74 \pm 0.20 \text{ m}\cdot\text{s}^{-1}$), suggesting that repeated cycles

may will decrease the sprint-paddling performance. This information may help to improve training and strategy planning.

Endurance paddling

Evaluating the surf endurance-paddling energy consumption in free water using direct measurements is a very hard task. The portability of the necessary equipment limits the area of data collection, and creates movement constraints for surfers. For this reason, the studies are typically conducted with tethered surfboard paddling (Lowdon et al., 1989), adapted ergometers on land (Farley et al., 2012; Furness et al., 2018; Loveless et al., 2010b; Mendez-Villanueva et al., 2005a), and recently with swim flume (Ekmeçic et al., 2017). However, previous studies (Bonen et al., 1980) have showed that tests performed on land ergometers underestimate the real efforts done during water locomotion.

The endurance paddling is quite variable about intensity and duration due to oceanic, climatic and atmospheric conditions (Meir et al., 1991). Few studies have monitored surf sessions in real oceanic conditions. Secomb et al. (2015b) reported mean velocities and distances covered of 52 m.min⁻¹, corresponding to 312 m in 6 minutes, including resting time dilution. Our endurance-paddling test has concentrated 6 minutes of work and showed higher covered distances (419.04 ± 38.86 m). The same authors reported paddle and duck dive of approximately 3 minutes to get back out beyond the breaking waves and registered 60% of paddling-time at intensities ranging from 56 to 74% of age-predicted HR_{max} and 3% of the exercise time close to 83% HR_{max}. Our protocol stressed the surfers considerably more; showing averages of 74% HR_{max} in the first minute, and 88% HR_{max} in the sixth minute (Figure 6-5). However, when comparing results with Secomb et al. (2015b) (HR_{mean} 131.1 ± 15.0 b.min⁻¹ and max of 177.2 ± 17.7 b.min⁻¹) and Meir et al. (1991) (HR_{mean} 135.0 ± 6.9 b.min⁻¹ and HR_{max} of 171.0 ± 7.5 b.min⁻¹), our results were similar and classified as moderate to vigorous intensity exercise (according to the American College of Sports Medicine).

Well-established swimming research techniques and resources, which respect the ecological patterns of the paddling movement into the water, supported our study. An oximeter with a snorkell (Baldari et al., 2013) ensured the necessary freedom to perform movements and turns like in real surfing situations, allowing continuous breath-by-breath oxygen uptake analysis (Figure 6-3c). Our $\dot{V}O_2$ kinetics curve reflected the adjustment of both systemic oxygen transport and muscle metabolism (Xu et al., 1999), and was fitted by a bi-exponential model (Zamparo et al., 2011) were: a) the fast component at the beginning of the exercise increased exponentially to a steady state level, traducing an oxygen deficit generated by the exercise demands, and b) the slow component that may represent an increase in the recruitment of low-efficiency type IIb fibres, causing an increase in the oxygen cost of exercise. Our tests are not maximal and the observed values are lower than those from Furness et al. (2018) who analyzed the $\dot{V}O_{2peak}$ of endurance paddling in competitive ($40.71 \pm 3.28 \text{ ml}\cdot\text{kg}^{-1}\cdot\text{min}^{-1}$) and recreational ($31.25 \pm 6.31 \text{ ml}\cdot\text{kg}^{-1}\cdot\text{min}^{-1}$) surfers. Other studies reported by Farley et al. (2016), showed the $37 \text{ ml}\cdot\text{kg}^{-1}\cdot\text{min}^{-1}$ as the lower value founded for $\dot{V}O_{2peak}$ during maximal surf paddling. To our knowledge, no other study has published oxygen uptake kinetics data during endurance-paddling in surfing.

Entire protocol

The sequence of tests was created in order to simulate the real conditions of a surf session. The paddling technique was not a purpose of the study. However, we invested special attention on the levels of intensity, combining maximal efforts, with long periods of intermediary to vigorous paddling intensity and resting time. Differences in blood lactate concentration were observed between surf paddling sprint and endurance-paddling. It would appear that no studies have analysed the energetic responses occurring in surf paddling cycle of similar loads, over a wide range of work-interval durations running from very short (10 s) to long (6 min) exercises.

The findings reported here confirmed our initial hypothesis regarding the lactate effects. Firstly, after an endurance-paddling the blood lactate reaches maximal concentration and, secondly, after the first cycle of sprint and endurance paddling a potentially fatigue-inducing component is added in the subsequent cycles, even with the available rest intervals. Additionally, our results demonstrated the multi-energy sources used during a surf session, and the specificity of each type of paddling addressed to different energy pathways, even analysing just the paddling intensities and durations.

Limitations and considerations

This work analysed the performance of surfers in a swimming pool performing the paddling action at different intensities, which is somewhat different from paddling in the ocean. In particular, salt water generates greater buoyant forces relative to fresh water, and these differences in buoyancy may contribute to differences in energy consumption. In addition, the tethered force test utilized a stationary paddling paradigm, but allowed to measure the arms paddling propulsion-generation ability. However, limitations in equipment have precluded testing in the ocean. Nevertheless the analyses described here were performed under highly controlled and repeatable conditions, which are very difficult to achieve in the ocean. Further, the paddling motions analysed in this study still biomechanically and energetically very similar to those performed in open water.

Conclusion

Together, the findings of this study offer an original assessment of bioenergetics during all-out and endurance surf paddling. Propulsion and velocity of the sprint-paddling apparently do not suffer the effects of endurance paddling and fatigue, if the resting time is respected. The endurance test brought new insights into the $\dot{V}O_2$ kinetics of surfers during the paddling action, which exhibited a bi-exponential behaviour with fast and slow components. Finally, the entire protocol showed an estimation of the energetic cost and proportion of the

energy pathways used during a surf session. These findings contributes to a better understanding of the energetic requirements in surfing.

Chapter 6

Fluid-Flow sensor for nautical sliding sports: a three dimensional transducer to measure direction and intensity of water's dynamic flow.

Márcio Borgonovo-Santos¹⁻³, João Paulo Vilas-Boas^{1,2}.

¹ Centre of Research, Education, Innovation and Intervention in Sport, Faculty of Sport, University of Porto, Porto, Portugal.

² Porto Biomechanics Laboratory (LABIOMEPE), University of Porto, Porto, Portugal

³ Surfing Viana High-Performance Centre – Surf Club Viana, Viana do Castelo, Portugal.

⁴ All in Surf Project - Science and Technology Park of University of Porto - UPTEC, Porto, Portugal.

INPI Provisional Patent Ref: DP/01/2017/40787.

Portugal National Patent nº 109368.

Abstract

The sensing device refers to a fluid intensity and direction flow measurement, in particular, but not exclusively water, which goes through the sliding surface of any navigable object. The measuring instrument comprises a mechanical frame, in which a central pin engages over around Maltese-cross like shaped. Once used, this pin undergoes a deflection by resisting liquid environment drainage. The pin, which is stiffer than the cross indented ends, triggers an effort transference which will cause differential deformations according to the different directions, which will be measured through electronic extensometry, varying the electric voltage with the deformation and with a linear response. Following the superposition theorem, adding one more amplifying electronic circuit and the sensor presents both analogic and digital channels as an output response.

Keywords: surf transducer, fluid flow, surfboard sensor, surf fluid dynamics.

Description

Fluid-Flow sensor for nautical sliding sports: a three dimensional transducer to measure direction and intensity of water's dynamic flow.

This invention refers to a sensor with three degrees of freedom. One device to measure fluid liquids flux of sliding objects on the liquid environment, with specific framing and design to measure intensity and direction of the passing fluid flow.

Field of the invention and related art

There are several basic principles to perform the transduction of the use of a physical force on electrical signals. Among them, mechanical sensors based on extensometry are the most common and well implemented. A plethora of commercial products is available in the market, including single or multi-axes sensitivity charge cells. Besides, researchers have designed several optimized mechanic profiles to implement three, four or six force sensor axes.

In the scope of sportive nautical activities, it is common to find measuring devices assessing the sliding object velocity, and therefore, water flow. These sensors comprise conventional turbine sensors, ultrasonic Doppler displacement sensors, acoustic transducers or other devices. Although users' well accepted, these are unidirectional measures based on measuring devices often placed on water turbulent areas. These kind of structures disregard any influence of perpendicular tides to the movement of sliding object. The performance of aquatic activities is directly affected by the water environment disturbances. This lack or limitation of the existing equipment, in relation to the other movement axes, hampers the dynamic and efficient reading process of object's real displacement on aquatic environment.

Some patents have been found in the search for devices comprising water flow three dimensional measurements: US 7437923 B2, describes a device to measure wind velocity and direction in particular, but also water. This device is based on magnetic measurement and holds moveable parts. Patent US 7166005

B2 describes a velocity indicator for surfboards and a data transfer apparatus with a multifunctional module involving an adjusted sensor to assess board displacement related to water. Patent US 20090042467 A1 also describes a velocity measuring device, which from one of the keels is able to measure velocity, grounded on the optical concept, measuring air bubbles displacement existing in water. Patent DE 19718917 C1 describes both an electronic sensor and a signal processing set for relative velocity determination and the relationship between water and a surfboard. The system is also based on a reflecting optical system. Patent US 6213041 B1 describes a velocity sensor for vessels. The system generally includes movable parts and a support covering, thus creating a funnel-shaped channel for water flowing. All the cited patents have measuring devices assessing unidirectional water flow and aim at the end to measure velocity, except patent US 7437923 B2. This device has the possibility to perform a bi-dimensional measuring. Nevertheless, as it holds moveable parts, it is both exposed to movement blockage by the lay of alien solid particles and to electromagnetic interferences depending on the dense or bubble- full water flowing through the set. None of the devices sought to overcome the sliding object limit layer and thus connect the sliding movement to the free layer of water flow.

Summary

The current invention describes a sensor device to effectively and precisely measure the intensity and direction of water flow passing by the surface of sliding objects in nautical sports.

The measuring device uses a multicomponent sensitivity principle and has been designed based upon the Maltese cross geometry, perfectly orthogonal and bidirectional. Best known as Maltese cross spring, this mechanical structure is designed to allow uncoupling the different components of a force.

The sensor (Figure 7-1) comprises a mechanical frame, in which a central pin (1) engages on a round base Maltese-cross like shaped (2). Once used, this pin undergoes a deflection by resisting liquid environment drainage. The pin, which is stiffer than the cross indented ends, triggers an effort transference which will cause differential deformations according to the different directions. The

design of the mechanical structure allows differentiating the dragging force imposed by water /fluid drainage, in relation to the object's sliding surface where it is held fast. The force found is measured in intensity and direction path in the three orthogonal axes (Table 7-1): X - anteroposterior, Y – latero lateral and Z – longitudinal/vertical with information on buoyancy during the movement. Therefore, this is a tridimensional sensor in relation to the sliding object, and can be used in a bi-dimensional way, just by removing the Z force detection ring (3).

Deformations are measured through electronic extensometry, which changes the electrical tension according to the deformation, with a linear response. When utilizing the electrical circuit superposition theorem, coupled to a differential amplifier, the sensor offers as an output response both analogic and digital signals (Figure 7-2).

The extensometer transducers are strategically placed on the Maltese cross indented ends (4) and glued on the opposite face of the sensor pin, in the region holding the largest elastic deformation. Beyond spotting force different components, mechanically, structurally and according to systems electronic combination, they perform a differential estimation for each axis of interest (Chart 1 – Estimation), strengthening, even more, the measuring sensitivity.

The sensor installation (Figure 7-3) onto the sliding object should meet the detectable axes guidelines (5). The slightest deformation imposed by water drag force might be detected. The sensor must be placed onto a self- base (6) and should be covered (7) to reduce the sliding interference.

The sensor pin was designed to rise above the limit layer of water drainage, thus overcoming the turbulence zone and accurately measuring the relative displacement between the sliding object and the water.

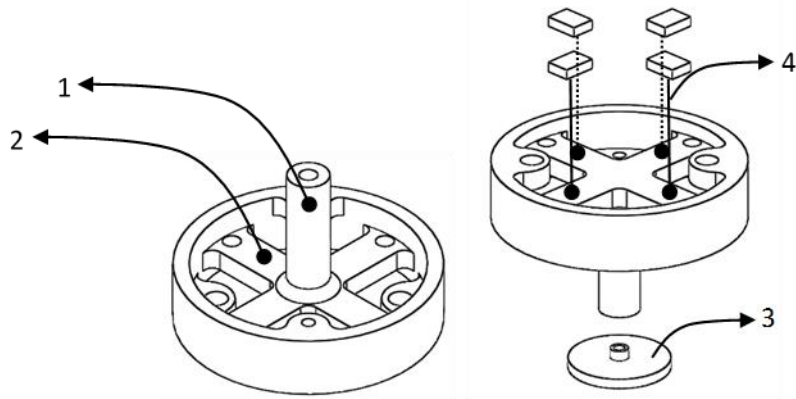

Figure 7-1. The transducer and the components

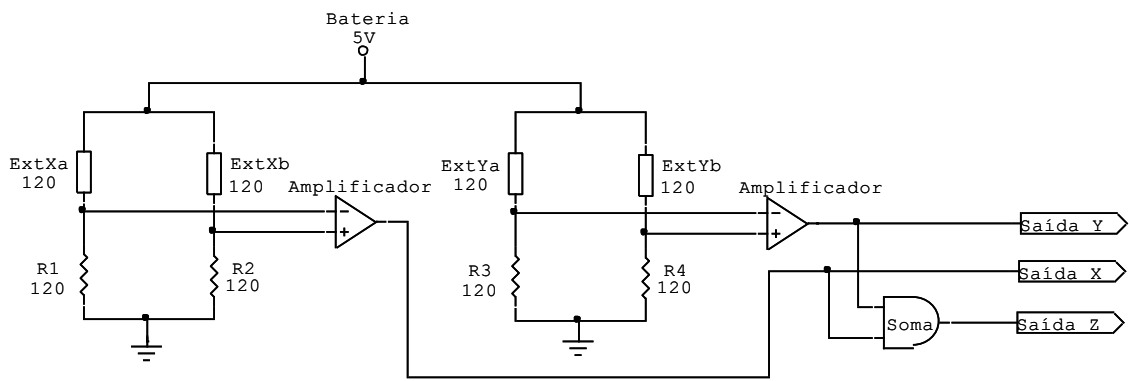

Figure 7-2. Schematic of the electronic amplifier circuit

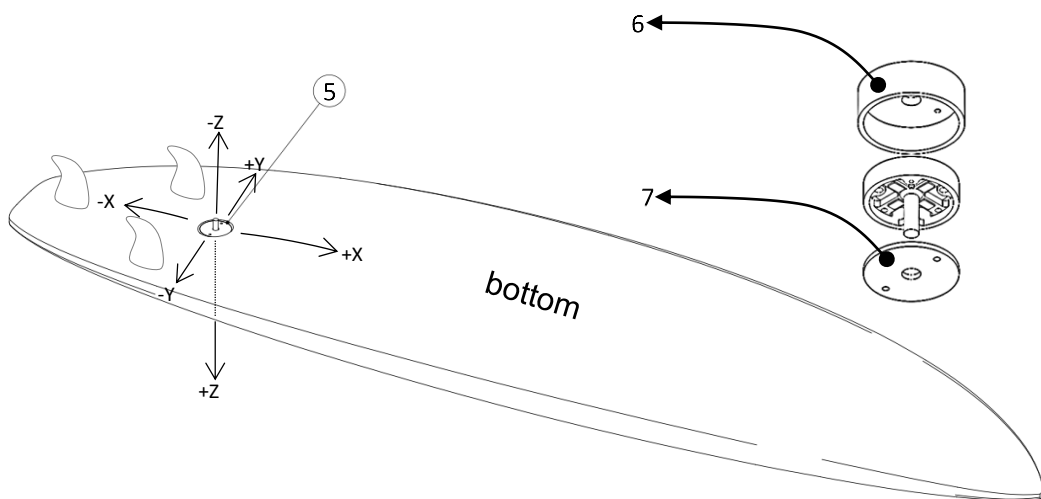
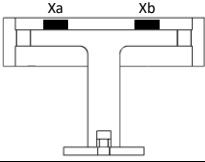
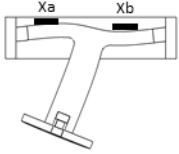

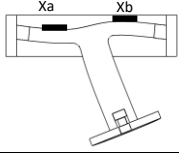

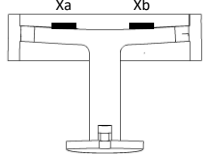
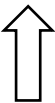
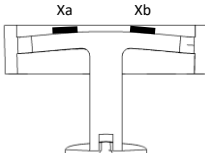
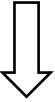

Figure 7-3. Position and axes orientation to place the sensor and their parts in the surfboard.

Table 7-1. Axes deformation, direction of displacement and equations of strain gauges.

| Example of axes deformation | Direction of surfboard displacement | Equations of strain gauges |
|---|---|---|
|  | Absence of forces | $V_X = (X_a - X_b) = 0$ $V_Y = (Y_a - Y_b) = 0$ |
|  |  | $V_X = (X_a - X_b) = 2X$ $V_Y = (Y_a - Y_b) = 2Y$ |
|  |  | $V_X = (X_a - X_b) = -2X$ $V_Y = (Y_a - Y_b) = -2Y$ |
|  |  | $V_Z = (X_a + X_b) + (Y_a + Y_b) =$ $X + Y = Z$ |
|  |  | $V_Z = (X_a + X_b) + (Y_a + Y_b) =$ $-X - Y = -Z$ |

Chapter 7

SADNA – System of Acquisition Data for Nautical Activities

Márcio Borgonovo-Santos¹⁻³, João Paulo Vilas-Boas^{1,2}.

¹ Centre of Research, Education, Innovation and Intervention in Sport, Faculty of Sport, University of Porto, Porto, Portugal.

² Porto Biomechanics Laboratory (LABIOMEPE), University of Porto, Porto, Portugal

³ Surfing Viana High-Performance Centre – Surf Club Viana, Viana do Castelo, Portugal.

⁴ All in Surf Project - Science and Technology Park of University of Porto - UPTEC, Porto, Portugal.

Submitted to Department of Innovation of Porto University – UPIN.

Process number NPAT271-16 – Utility model.

Under review.

Abstract

Competitive aquatic sliding sports still lack effective technologic resources for obtaining data on performance. The key problem is to determine movement parameters during the activity, in real time. The present invention refers to a system to monitor, record, transmit, interpret and provide in a user-friendly information about performance in water sliding sports.

Keywords: surf analysis, surf analytics, instrumented surfboard, surf technology.

Description

SADNA – System of Acquisition Data for Nautical Activities

The invention refers to a system to monitor, record, transmit, interpret and provide in a user-friendly way information about navigation in water sliding sports. This information can remain stored within the system and/or be transmitted through conventional wireless protocols for data transfer.

The system comprises a microcontroller, monitoring sensors, and control firmware, math's estimation for variable transformation, grouping of organized data and, lastly, transmission and reception through well-established wireless communicating protocols, data treatment and data system acquisition view.

Field of the invention and related art

Nautical sliding sports comprehend all the modalities, in which the practitioners use an instrument/apparatus where their body is held aiming to improve the efficacy of aquatic displacement.

Competitive nautical sports still lack effective technologic resources for obtaining data on performance. Currently, beyond footage, market offers do not respect the basic conditions of a measuring device. The key problem is to determine movement parameters during the activity, in real time. The existing systems influence or interfere with the practice and are too heavy, energy consuming, without data output compatibility, presenting miniaturization inability and high production costs. It is quite common to find devices performing isolating measurements well accepted by the users, although those are seen isolated, and therefore ill-defining the whole event in performance.

Some patents have been encountered in the quest to find the needs of this measurement:

Patent DE 33 19 684 A1 uses the turbine principle, although affecting de surfboard sliding.

Patent GB 22 04 705 uses a differential pressure sensor. Nevertheless, these sensors raise the board drag.

Patent DD 227 329 A1 uses incandescent wires but the saltiness difference interferes with the accuracy of measurements.

Patent DE 85 23 456 U1 describes an inductive magnetic sensor, being the sensor size too large, thus interfering in performance.

Patent US 7166005 B2 describes a velocity indicator for surfboards and a data transfer apparatus, comprising a multifunctional module, which involves an adjusted sensor to assess the dislocating board connected to the water.

Patent US 20090042467 A1 also describes a velocity measuring device, which from one of the keels is able to perform velocity measurements based on an optical concept, measuring the air bubbles displacement existing in water.

Patent DE 19718917 C1 reports a device comprising an electronic sensor and a signal processing to the relative determination of velocity and the relationship between the water and the surfboard. The system is also based in a reflection optical system.

Patent US 6213041 B1 describes a velocity sensor for vessels. The system comprises movable parts and a supporting cover, thus creating a funnel-shaped channel for the flowing water.

The cited patents have measuring devices assessing unidirectional water flow and aim to measure velocity.

All the devices have neglected to overcome the sliding object's limit layer, and therefore connecting the sliding movement to the water flow free layer.

Summary

The current invention is integrated into the scope of monitoring systems, apparatus, techniques and usage. It reports a data acquisition system, which enables nautical sliding sports practitioners, spectators, coaches and others, to follow and/or evaluate the sportive performance in recreational practice, training and competition. Nautical sliding performance activities are directly affected by the water disturbances. Therefore, this method and this system have been designed to allow the integration of different components of movement happening

with the sliding object, including environmental variables. Hence, it will be possible to analyse and forward this data.

This invention, as described, enables these control systems, their components and the methods used to be operational and effective, and profit from the advantages and acknowledged benefits.

The system contains: GPS, real-time clock, Inertial Measure Unit, 3D fluxometer, temperature sensor, pressure sensor, besides other analogic and digital outputs, allowing additional sensors entrance. The system also holds another components, such as electric power source, memory card, visual indicators and control buttons. Communication components are totally changeable, once data obtained are orderly grouped, synchronised with a high precision watch and can be sent through any communicating protocol, via data packets, enabling real-time analysis. Additionally, all data are memory card registered for further analysis.

The system must be set in the sliding object/equipment/apparatus, preferentially in its centre of mass, as this is the place that represents all the inertial forces trustworthy. However, when set in other places it is possible to generate corrections according to the distance to place.

Video Synchronisation

The system promotes a timestamp for each acquisition in high frequency and records GPS data according to module frequency, allowing temporal adjustments and corrections. It also has a general trigger, enabling its synchronization with any other systems providing this option.

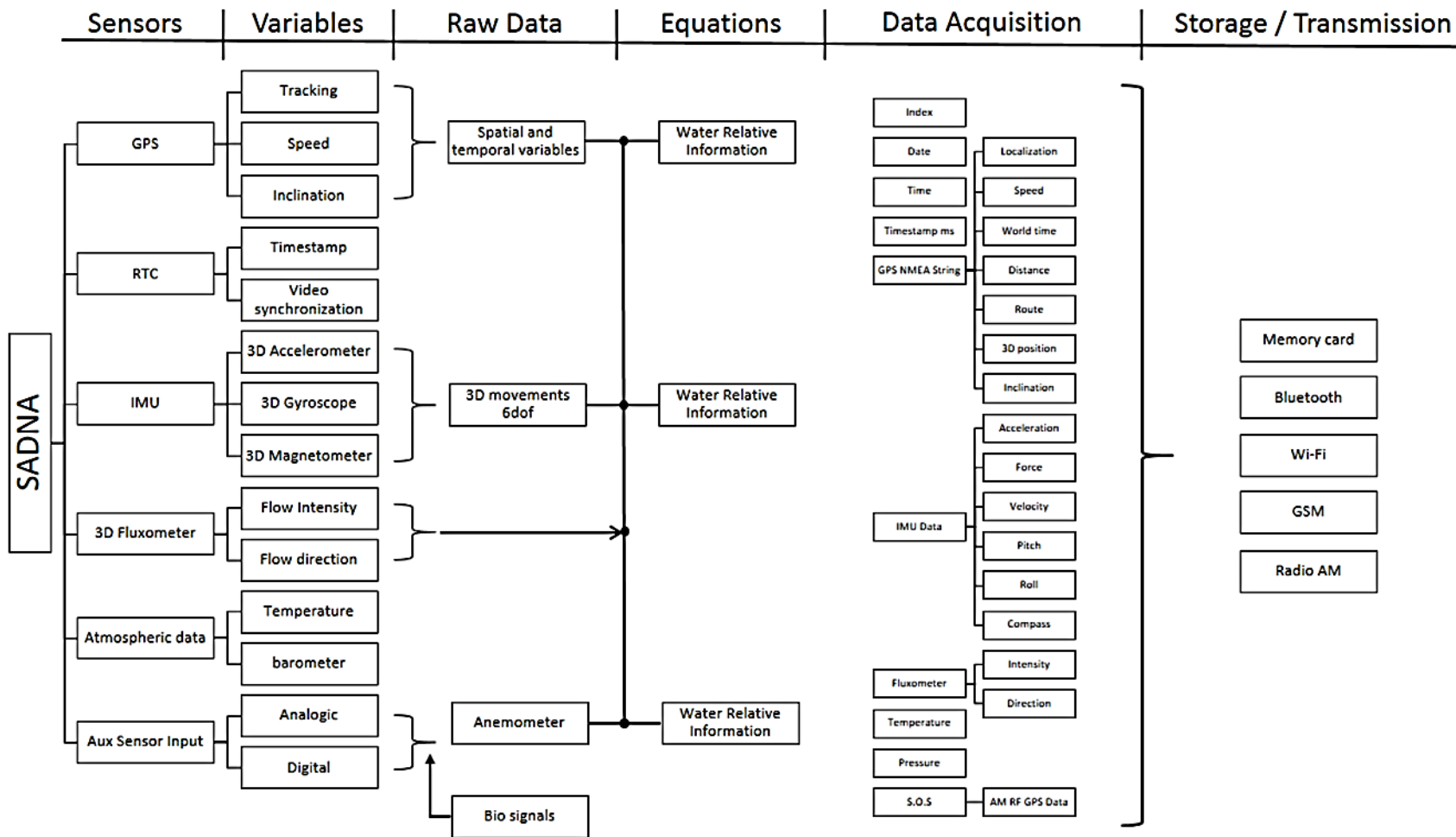

Figure 8-1. Structure of sensors, variables, transformation of variables and transmission.

Chapter 8

The mOceanSense Startup - from science to business

Márcio Borgonovo-Santos¹

¹UPTEC – Technological Incubator of Porto University



Executive Summary

Nowadays, nautical athletes do not have access to reliable Key Performance Indicators - KPIs. The technologies available are not able to provide this type of information.

We will be the reference system in the analysis of metrics for water sports, and we will be present in all aquatic equipment: surfboards, sailing, vessels, kayaks, and much more. Our strategy to reach the market begins by providing services for broadcasters of nautical sports. For the first time, they will be able to transmit live performance metrics.

mOceanSense is the combination of “motion” analysis, in the “ocean” and aquatic environment, measured by “sensors”. In this way, our principal focus now is oriented to deliver the best live sports performance, evaluation and interpretation, throughout telemetry and interactive dashboards for broadcasting in nautical sports. Tools for analysing sports performance on water are practically non-existent. This is a transversal need for all sliding nautical sports, where there is no analytical information.

From now on, the community will be able to watch a nautical sports competition from a broadcast (TV and Internet), while interacting through performance analyses, statistics comparison, and share this in the social media. We compile in a single device the latest motion track technologies, highlighting our 3D water flow. An invention that broke all barriers and allows, for the first time, accurate motion-analysis with real effort measurements in the aquatic environment. Additionally, algorithms of interpretation relativize the ground-referenced information with the water flux data. Providing for the first time, metrics that reflect the real phenomena and forces involved in the sliding nautical sports.

Our technology and methodology have been tested and proven in laboratory conditions and in real-world tests since 2011. In 2015, we did a successful pilot test in the giant waves of Nazaré and now, after a maturing phase, we are ready to evolve our system, but principally our business.

Through this new analytical information, we begin to change all the paradigms of nautical sports evaluation. We are revolutionising the way people watch, train, judge and perform in nautical sports.

EXCELLENCE

Challenge

The improvement of the home viewing experience has challenged sports teams, broadcasters, and companies to think about how they can better draw their audience. Data and analytics in sports typically concentrate on the land sports. This is because there are practically non-existent tools to aid in performance analysis in nautical sports, and analytical information to assist in this context is unknown.

Another very important point is related to the competitions. Nowadays, all judgments and scores are based on visual feedback and practical experience - empiricism. This uncertainty in the punctuations results in many errors and misunderstandings. The quantitative information about nautical sports performance, or precisely relative to wave's, ocean, and river measurements, currently, does not exist.

One of the most significant trends in sports is the experience transformation resulted from the use of big data, machine learning, artificial intelligence and virtual reality (VR). Having the best players is critically important, but so is having key insights to create better fan experiences, drive more revenue, and create more value.

The mOceanSense project is bringing to the sports market a new product and service for nautical quantitative analysis in real-time. Combining all available technologies for motion track associated with our innovative fluid flow sensor, which allows for the first time, the correction of ground-referenced measurements with the water flux. In the practical issues, this means real efforts measurements.

Approach

The technological resources and methodology here used have been tested and proven in laboratory conditions and in a conceptual way – an important pilot test in October of 2015, resulting in a documentary for the ZDF German TV. In other words, we have developed a system capable of acquiring 3D navigation data with scientific quality. More than this, now it is possible to analyse in detail with statistics support, what really happens during the key moments of every nautical sport – We can now access a virtual cockpit of the nautical athlete's in action.

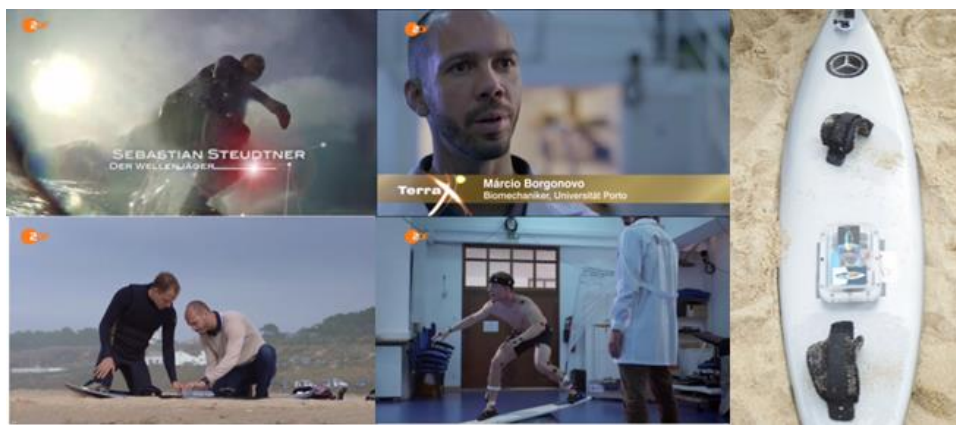

Figure 9-1. Ocean pilot study in Nazaré-PT and laboratory analysis with the world champion surfer of giant waves Sebastian Steudtner. Surfboard and prototype assembled.

From now on, the community will be able to watch a nautical sports competition from a broadcast (TV and Internet), while interacting through performance analyses, statistics comparison, and share this in the social media. It is important to clarify that we create a hardware solution, software solution, and a platform that integrate both. This technology is suitable for any nautical sport. However, with specific algorithms, it is possible to deliver special packs of data analytics for specific sports (e.g. sailing, rowing, surf, canoeing, etc.) for deep and differentiated analysis.

Comparative product analysis



Figure 9-2. Competitors.

Table 9-1. Product features comparison.

| GPS + IMU parameters | Competitors | mOceanSense |
|-----------------------|-------------|-------------|
| Velocity | incorrect | ✓ |
| Displacement | ✓ | ✓ |
| Full trajectory | ✓ | ✓ |
| Water flow | X | ✓ |
| 2D/3D direction | X | ✓ |
| Intensity | X | ✓ |
| Effort relativization | X | ✓ |
| Derived parameters | X | ✓ |

All the competitors' use inertial principles or GPS information to show simple metrics related to time vs. displacement relation. However, none uses another resource that combine global positioning information with the water displacement. This means that all measurements do not represent the real effort performed by the practitioners.

The prices practised by the competitors round around 200,00 €. They offer an application and platform to support the interaction with the measured data. These products are directed to B2C and nowadays we do not identify any product directed for broadcasting with live transmission features.

IMPACT

Entering the market

Our market analysis has shown that it is very difficult to quantify the number of potential customers or market value size. This, because our product is a completely innovative solution that can be applied to all nautical gliding sports. Though we have been doing our homework, and following the two market megatrends¹ “broadcasting with real-time data analysis” and “analytical in sports performance”, so it is too early to decide for a specific sport.

The expectations for the sports analytics market² is to grow from USD 123.7 million in 2016 to USD 616.7 million by 2021, at a Compound Annual Growth Rate (CAGR) of 37.9%. With the arrival of live streams and events, substantial demand for new sports has entered the realm of broadcasters and media that can now apply their business models to a market previously out of reach for them.

The nautical Olympic sports represents a huge opportunity. In this context, the metrics for performance evaluation are essential to assist the improvement of training methodologies, coaching, judgments, equipment improvements and much more. One of our advantages is the use of our fluid flow sensor, which allows inferring the real efforts performed during the activities.

By the reason that is no technology for nautical sports analysis that solves the water displacement correction, our system is the only tool that delivers accurate metrics of performance. None of our competitors uses this type of technology. Competitive advantages:

- Know-how – PhD Sports Sciences – Surf Biomechanics / Exergames VR.
- Trade Secrets – Development of pattern recognition algorithms (database).
- Scientific Material – Normative database, validated assessment protocols.

¹ Reportsnreports; Nielsen Sports; Deloitte's; Market Watch; Newzoo; Global Industry Analysis.

² MarketsandMarkets

- Network – Nautical High-Performance Centres - protocols
- Patentable – Sensor and utility model (data acquisition system).

The opportunities identified for market penetration: broadcasting, sports federations/organizations, sports/research facilities, and final customer. Nevertheless, we are working to realize, which is the best and most profitable market to approach, in order to reach our goals as fast as possible.

Risk

The potential of this project is indisputable, but there are barriers that need to be overcome for its success, by interpreting the SWOT Analysis table, we identify in descending order of priority the most important actions to be taken:

Table 9-2. SWOT Analysis

| | Positive | Negative |
|-------------------------|---|---|
| Internal | Strengths | Weaknesses |
| | • MVP tested and Working | • Small team |
| | • Innovative product | • Lack of financial resources |
| | • Innovative service | • Not yet commercial |
| | • Geographic Location | • lack of sales and distribution channels |
| | • Network | |
| • Patentable technology | | |
| External | Opportunities | Threats |
| | • Olympic Games 2020 | • Unexplored market |
| | • Growth of the sports analysis market | • Potential for competitors to emerge |
| | • Potential of application in several areas | • Fail to obtain the necessary investment |
| | | • Pricing |
| | | • Non-acceptance of the market |

Patent: Submitting the patent, will make this project more attractive to investors, providing also some level of security against potential competition.

Ensuring investment: For the project, implementation is of the utmost importance and an effort must be made in this regard.

Team: Formalization and stabilization of a team that meets all the needs of the company, product development, app development, management, sales, and marketing, in this way we will ensure the execution of the tasks fulfilling deadlines and objectives.

Market penetration: Our partner and investor provide easy access to the broadcast market. Thus, we want to sell them our services, followed by mass production and sell B2C (final consumer).

Pricing: It should have been taken into account from a preliminary stage the cost of production issue, will allow us to set the final price according to our strategic needs, and market positioning, ensuring a good profit margin, and negotiation power with customers.

Business Model

We understand the enormous potential of our technology, and we recognize the great seriousness of being fully focused on this start-up phase. Therefore, according to our approach strategy, deliver services for broadcasting is the main goal. This, to ensure efficient market penetration, and receiving feedback from top athletes, especially avoiding all the costs and risks associated with mass production, for a specific market.

Despite the strategy for this first year, we are vigilant for opportunities to make the first sales and licensing the product for other markets, in the way to validate and certify the product.

We identified some important revenue streams:

- Sale of the sensor in the market / Application subscription;
- Sale of a service pack for broadcasting with real-time measurements;
- In the future license the sensor for other water sports;
- Advertising and advertisement on the application / platform;

Financing

After a few years of development, proof of concept and market feedback, we decided in October 2017, to actively seek financing to transform the mOceanSense project into a real business. As result of this work, the European Space Agency (ESA) awarded us for the development of the commercial version of our system.



Figure 9-3. Two-in-One prize and recognition. Ricardo Marques representing mOceanSense.

Intellectual Property Right and legal framework

We have been cautiously evaluating our IP strategy, weighing it against other possibilities, as keeping our technology solutions as a trade secret. An initial research has been conducted to assess the patent feasibility and current “Freedom to Operate”. Recently we met with experts in the “Patents.PT” Office, to start the assessment and validation of its technology and the associated competitive advantage. mOceanSense technology contains several innovations that can be patented: hardware solution, constructive method, calibration systems, acquisition system and algorithms for movement analysis.

Contextualization

Nautical gliding sports comprehend all the modalities, in which the practitioners use an instrument/apparatus for aquatic displacement. Competitive nautical sports still lack effective technologic resources for obtaining data on performance. Currently, beyond footage, market offers do not respect the basic conditions of a measuring device. The key problem is to determine movement parameters during the activity, in real-time. The existing systems influence or interfere with the practice and are too heavy, energy consuming, without data output compatibility, presenting miniaturization inability and high production costs.

The mOceanSense technology results from the combination of a back-end system that comprises a global positioning (GPS), local positioning (inertial motion track sensors) and media environment reference (our fluid flow sensor); and a front-end platform that receives, analyse, interpret and makes the information available to the public in a user-friendly way.

The fluid flow measurements

In the scope of sportive nautical activities, it is common to find measuring devices assessing the gliding object velocity, and therefore, water flow. These sensors comprise conventional turbine sensors, ultrasonic Doppler displacement sensors, acoustic transducers or other devices. Although users' well accepted, these are unidirectional measures based on measuring devices often placed on water turbulent areas. This kind of structures disregards any influence of perpendicular tides to the movement of gliding object. The performance of aquatic gliding activities is directly affected by the water environment disturbances. This lack or limitation of the existing equipment, in relation to the other movement axes, hampers the dynamic and efficient reading process of object's real displacement on the aquatic environment.

Our invention refers to a 3D sensor device to measure fluid liquids flowing on the surface of gliding objects on the liquid environment, with specific framing and design to measure intensity, direction and path. The measuring device uses a multicomponent sensitivity principle - patentable.

The System

We developed a system to monitor, record, transmit, interpret and provide in a friendly way, information about navigation performance. This motion data can remain stored within the system or be transmitted through conventional protocols for data transfer. The system comprises a microcontroller, monitoring sensors, control firmware, math's estimation for variables transformation, a grouping of

organized data, and lastly transmission and reception through well-established communicating protocols, data treatment and data system acquisition view.

The Platform

The platform provides out-of-the-box components

- Data collection; Customizable end-user dashboards;
- Advanced and visualization for real-time and historical monitoring;
- Alarm widgets to pro-actively react to any situations in the shortest time;
- Integration with third-party analytics frameworks

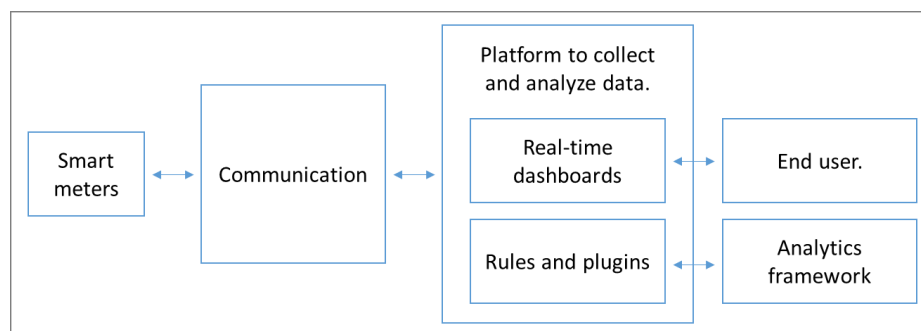

Figure 9-4. Diagram of the platform structure.

In Figure 9-5 it is possible to see an ex-post analysis, recorded in synchronization with video record. The dashboard applied in this video can show a little example of the potential of our technology.



Figure 9-5 Example of GPS information showing wrong information, and our fluid flow sensor measuring the real speed.

Environmental and Social Benefits

Our product has no direct impact on the environment, so we believe that it can help and lead more people to practice water sports, by helping to raise awareness of problems and climate change.

On the other hand, there are millions of nautical sports practitioners around the world, with the mass utilization of mOceanSense device; we will be able to monitor parameters from the oceans, e.g., water quality / pollution, PH index, temperature, salinity and currents.

IMPLEMENTATION

Team

The mOceanSense values are literally “to make the things happen”, this means: innovate (through research, creativity, trial and error); persistence (always looking to the challenges and believing that we have the skills and strength to surpass the obstacles, and if we do not have, we can develop competences); and resilience (looping in the process of learning with our fails, and improve).

The team has expertized in a number of disciplines, i.e., business development, project management, product-sensor-software development,

engineering, sports sciences, data analysis. Nevertheless, not less important, we all love the ocean and surfing.

The vision of creating and commercialize a totally new approach to analyse performance in nautical sports, is what brings experience, talent and passion together to undertake new challenges and exploit business opportunities.

The strategic partnerships are particularly important for an innovative start-up. For this reason, we identified partners that are crucial, not only as customers but as promoters and certifiers of the quality of the product and service.

Partners in Portugal: Porto Biomechanics Laboratory, University of Porto; Faculty of Sports, University of Porto; Pedro Nunes Institute – European Space Agency Business Incubator Centre; Surf High-Performance Centre – Viana do Castelo. Brazil: Aquatic Biomechanics Laboratory of Santa Catarina; Sports Faculty of Amazonas. Germany: Lead Sports Accelerator Program – Berlin. United States: InRes Carnegie Mellon - PA; Center for Surf Research – CA.

Advisors: Dr Jess Ponting, Center for Surf Research – San Diego – CA, US; PhD Jeff Nestler – Activity Sports Biomechanics – San Marcos – CA, US; PhD João Claro – Business Development - Carnegie Mellon Portugal InRes Team – PT; Vitor Verdelho - President of European Algae Biomass Association, Porto – PT

COMPANY

The project emerged from a PhD research, where surfing was investigated in a controlled environment. Laboratory tests were carried out, both with general performance analysis of physical activity and with surf movement's simulation, as well as in swimming pools equipped with the best tools that exist in the context of biomechanical analyses of movements performed in the water.

The first scientific investigations in the world of the surf were faced with a classic difficulty of the world of science, which is to measure without interfering. The maritime environment is extremely hostile to electronic components, which are currently our largest source of quantitative information.

Casualmaneuver Lda is a company created in January of 2018; this company owns the rights of exploitation of brand domain and intellectual property

of mOceanSense. Although recently created the mOceanSense is a project with years of R&D work, this project started 2011 by the passion of its founders for surf and technology, by creating a way to make surf easier and more accessible to all, and had the name of Allinsurf. At the end of the year 2017 in a strategic way, we decided to change the name AllinSurf to recently created mOceanSense, to broaden the scope of the company's performance, not being limited to the surf market.



Figure 9-6. mOceanSense team in the Porto Biomechanics Laboratory – LABIOMEPU.

The renamed mOceanSense project, during the last 7 years, accumulate some participation in a series of start-up's programs. It is important to highlight the notorious programs: The Carnegie Mellon Portugal (in-residence program to understand the USA market – 90 days). The Lead Sports – Adidas family (residence program to catch investment – Berlin, Germany).

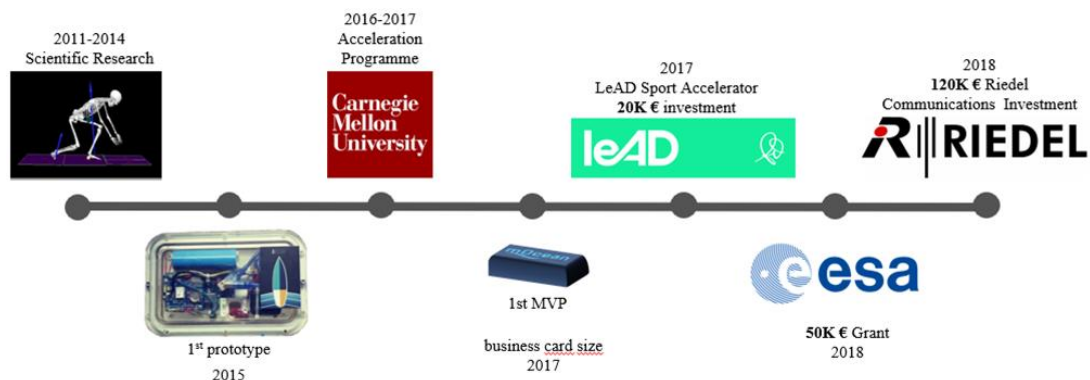

Figure 9-7. History line of the mOceanSense project.

Facilities and key partners

The mOceanSense is incubated in the technological centre of the Porto University, more precisely at the sea pole, where we have at our disposal a workshop, extremely well located given its proximity to the sea and local water sports clubs. In addition, given the background of the mOceansense team, we have easy access to excellence engineering and biomechanical laboratories.

Other services such as financial consulting and legal support, software development, cloud services, will be outsourced if and when required.

All our development up to this stage was done based on these partnerships and network. We want to see strengthened for the future.



Figure 9-8. Research network and partners.

Chapter 9

General Discussion

This thesis was based on the pillars of scientific research, with an exploratory character, combining experimental, descriptive and technological development aspects. The approaches used here provided an accurate view of the techniques performed in the horizontal phase of surfing. More than that, it has opened doors to a new world of research, directly in the surfing practice environment.

Systematic review

The main function of our systematic review was to guide our vision. It allowed knowing the scientific reality existing in the world of surfing. As well, identify the areas not yet explored. In addition, it was possible to gather the strengths and weaknesses of all the protocols used. It became clear that two main trends were leading the researchers. One focused on the natural activities of surfing, and one directed towards the abilities and physical capacities of individuals. In this way, it was possible to adapt and improve our methods of research. However, it was somewhat surprising, there were no studies with didactic purposes to understand the movements of surfing. This led us to ponder that there was a significant lack of equipment that allowed, among others, this kind of analysis of movement in the ocean.

Surf paddling's

The technologies applied to explore the surf paddling in this thesis comes mainly from the knowledge of swimming and customized equipment developed to improve the data collection (Appendix I). All protocols were performed in the pool, always pursuing the closest approximation to the natural practice, and minimizing the constraints.

Paddling is the main type of aquatic locomotion in surfing. It is responsible for allowing the surfer to enter the sea, to position himself, and finally approach the waves. A pilot study was performed (Appendix II) to test and improve the methods and procedures of application to the principal data collection. The tests carried out allowed us to find new parameters and results. One of the important findings, regarding the power paddling, is related to the efforts relativization. It is clear that normalized information is an important factor in the training preparation, where the individual production of propulsive force must be considered.

Another important finding is related to the trainable capacity to achieve maximum velocities faster, allowing an efficient regime between the production of propulsive force and the displacement. This means overcoming the high inertial loads and the drag force in the first moments of the paddling action. These variables can be easily improved by training.

The pop-up technique

This technique closes the horizontal phase of the surf. Its execution makes possible the transition to the vertical standing position. An ecological validation study was carried out after a pilot test (Appendix III) in order to understand if components of motor actions transference were present in the laboratory performance. Despite being a very simple study, the results pointed to a similarity in execution time and technique.

The study of the pop-up becomes a pioneer in what concerns the deconstruction of the technique by fragmented analysis for a general understanding. This type of approach shades new lights and new perspectives, which can now be directed to the learning processes, improvements in the technique execution, and even changes in surfboards characteristics. Now, the previously qualitative and estimated variables were quantified as a reference starting point.

Surf paddling cycle energetic profile

As a free surfer, one tries to recreate the uncountable times paddling in the ocean to cross the waves' break zone, and sprint-paddled to catch some waves. Surfers repeat this cycle so many times that makes one think: How much is the energetic cost of one cycle? Sometimes the sea is generous, sometimes not. Our protocol takes into account the individual surfer performance to calculate how the energetic cost of a sequence of paddling's is, and try to understand how the endurance-paddling can interfere in the special moment of sprint paddling to catching waves. Basically, we observed that the resting time is important to ensure that, once positioned in the surf zone, we are able to choose the wave, and have enough energy to make the best approach on the wave. Now, understand how to slide in the wave, surf itself, and perform some manoeuvre, will be another thesis. Although we are focused on intensity, the technical aspects have been tested in a pilot study (Appendix IV) and show that simple methods of analysis, such as noseboard tracking, can assist in rowing technique improvements, improving efficiency and saving energy.

The technological development

In the world of surfing is extremely difficult to obtain analytical information about the parameters of performance. Currently, the analysis and judgment of one surf session are based on empirical knowledge, experience, visual feedback, and procedures that involve great measurement errors.

Our technology has successfully passed the proof of concept and we have fruitfully completed the first important pilot test with a world top level professional surfer. Everything gains much more power since the Surf was selected as a sport for the 2020 Olympics. All the resources used so far have allowed us to create a minimum value proposition and offer a product that solves an important need in the nautical sports market.

All the methodologies here applied are transversal to other surfing activities like the bodyboarding, and the first explorations were performed (Appendix V).

Chapter 10

Conclusions

In our research, we aimed to characterize the prone-phase until the transition-phase to a stand position under different approaches. The presented studies have provided new methods for surfing analysis and designed better and more meaningful parameters of evaluation. We measured the biomechanical parameters of sprint-paddling (force and velocity), endurance-paddling (energy cost) and the pop-up manoeuvre (characterization). Following the results obtained in the studies presented in this thesis, it is pertinent to stress out the following conclusions:

Surf sprint-paddling performance is an indispensable skill for catching waves, ensure better positioning and priority. The methodology and tests used were shown to be an effective measure of the force and velocity parameters under ecological conditions, respecting functional movements.

The pop-up execution is influenced by the different challenges imposed by the ocean, however, the simulation in laboratory reach the expected representativeness of the motion. This methodology allows decoposing the technique in didactical phases observing the symmetries and natural asymmetries unknown until now.

The surf cycle revealed important information regarding the energy cost of a surf paddling cycle, and how important is to respect the recovery time between successive power paddling bursts. Indeed, the endurance-paddling, in moderate to vigorous intensity, affects the global energy system making evident the fatigue effects. These new insights contribute to a better understanding of the existent ratio between paddling actions and recovery phases.

Finally, the developed data acquisition system has reached many triumphs, unimagined at the beginning of this project. However, it proved to be very useful in relativizing performance measurements and making them possible,

allowing to analyse movement in real time. The challenge to transform this simple idea in business is a path that will continue to be trodden.

Chapter 11

Suggestions for Future Research

Our studies resulted in several recommendations for future research from the point of exploration, but principally regarding to the technologies developed. To validate the technology, build a robust database and improve the protocols will be a big challenge.

The future research will take place on the ocean with real-time data acquisition and analysis. The improvement of the system performance and the quality of the information is dependent of the creation of a database with different types of surf practices and characteristics. However, now it will be possible to acquire kinetic and kinematic data synchronized with video in loco. This kind of approach will open a new world in the surf analysis.

The Olympic Games will be an excellent opportunity, once apparently and expectedly, surf will become more professionalized and organized. In this context, the metrics for performance evaluation will be fundamental to assist in the decision making of training and judgements.

Chapter 12

General References

- Alcantara, C. P. A., Prado, J. M., & Duarte, M. (2012). Analysis of the balance control in surfers during the erect posture. *Revista Brasileira de Medicina do Esporte*, 18(5), 318-321.
- Anthony, C. C., Brown, L. E., Coburn, J. W., Galpin, A. J., Tran, T. T., Meir, R., & Farley, O. (2016b). Stance affects balance in surfers. *International Journal of Sports Science & Coaching*, 11(3), 446-450.
- Araújo, D., Davids, K., & Passos, P. (2007). Ecological Validity, Representative Design, and Correspondence Between Experimental Task Constraints and Behavioral Setting: Comment on. *Ecological Psychology*, 19(1), 69-78.
- Axel, T. A., Crussemeyer, J. A., Dean, K., & Young, D. E. (2018). Field Test Performance of Junior Competitive Surf Athletes following a Core Strength Training Program. *International Journal Of Exercise Science*, 11(6), 696-707.
- Baldari, C., Fernandes, R. J., Meucci, M., Ribeiro, J., Vilas-Boas, J. P., & Guidetti, L. (2013). Is the New AquaTrainer® Snorkel Valid for VO₂ Assessment in Swimming? *Int J Sports Med*, 34(04), 336-344.
- Barlow, M. J., Findlay, M., Gresty, K., & Cooke, C. (2012). Anthropometric variables and their relationship to performance and ability in male surfers. *European journal of sport science*, 14(sup1), S171-S177.
- Barlow, M. J., Gresty, K., Findlay, M., & Cooke, C. (2015). Associations of Power at VO₂peak and Anaerobic Threshold with Rank in British High Performance Junior Surfers. *Human Movement*, 16(1), 28-32.
- Barlow, M. J., Gresty, K., Findlay, M., Cooke, C. B., & Davidson, M. A. (2014). The Effect of Wave Conditions and Surfer Ability on Performance and the Physiological Response of Recreational Surfers. *Journal of Strength and Conditioning Research*, 28(10), 2946-2953.
- Barlow, M. J., Gresty, K., Findlay, M., Cooke, C. B., & Davidson, M. A. (2014). The effect of wave conditions and surfer ability on performance and the physiological response of recreational surfers. *The Journal of Strength & Conditioning Research*, 28(10), 2946-2953.
- Barlow, M. J., Rowe, J., Ruffle, O., Davidson, M., & O'Hara, J. (2016). Anthropometric and performance perspectives of female competitive surfing. *Human Movement*, 17(3), 154-161.
- Bassey, E. J. (1998). Longitudinal changes in selected physical capabilities: muscle strength, flexibility and body size. *Age and Ageing*, 27(suppl 3), 12-16.
- Baty, F., Ritz, C., Charles, S., Brutsche, M., Flandrois, J.-P., & Delignette-Muller, M.-L. (2015). A Toolbox for Nonlinear Regression in R: The Package nlstools. *Journal of Statistical Software; Vol 1, Issue 5 (2015)*.
- Bencke, J., Damsgaard, R., Saekmose, A., Jørgensen, P., Jørgensen, K., & Klausen, K. (2002). Anaerobic power and muscle strength characteristics of 11 years old elite and non-elite boys and girls from gymnastics, team handball, tennis and swimming. *Scandinavian Journal of Medicine & Science in Sports*, 12(3), 171-178.

- Binzoni, T., Ferretti, G., Schenker, K., & Cerretelli, P. (1992). Phosphocreatine hydrolysis by ³¹P-NMR at the onset of constant-load exercise in humans. *Journal of Applied Physiology*, 73(4), 1644-1649.
- Bogdanis, G. C., Nevill, M. E., & Lakomy, H. K. (1994). Effects of previous dynamic arm exercise on power output during repeated maximal sprint cycling. *J Sports Sci*, 12(4), 363-370.
- Bonen, A., Wilson, B. A., Yarkony, M., & Belcastro, A. N. (1980). Maximal oxygen uptake during free, tethered, and flume swimming. *Journal of Applied Physiology*, 48(2), 232-235.
- Bravo, M. M., Cummins, K. M., Nessler, J. A., & Newcomer, S. C. (2016). Heart Rate Responses of High School Students Participating in Surfing Physical Education. *J Strength Cond Res*, 30(6), 1721-1726.
- Bravo, M. M., Cummins, K. M., Nessler, J. A., & Newcomer, S. C. (2016). Heart Rate Responses of High School Students Participating in Surfing Physical Education. *The Journal of Strength & Conditioning Research*, 30(6), 1721-1726.
- Bruton, M. R., Adams, R. D., & O'Dwyer, N. J. (2017). Sex Differences in Drop Landing: More Apparent in Recreational Surfers Than in Competitive Surfers or Nonsurfers. *Percept Mot Skills*, 124(5), 992-1008.
- Coyne, J. O. C., Tran, T. T., Secomb, J. L., Lundgren, L., Farley, O. R. L., Newton, R. U., & Sheppard, J. M. (2016). Association between anthropometry, upper extremity strength, and sprint and endurance paddling performance in competitive and recreational surfers. *International Journal of Sports Science & Coaching*, 11(5), 728-735.
- Coyne, J. O. C., Tran, T. T., Secomb, J. L., Lundgren, L. E., Farley, O. R. L., Newton, R. U., & Sheppard, J. M. (2017). Maximal Strength Training Improves Surfboard Sprint and Endurance Paddling Performance in Competitive and Recreational Surfers. *The Journal of Strength & Conditioning Research*, 31(1), 244-253.
- Coyne, J. O. C., Tran, T. T., Secomb, J. L., Lundgren, L. E., Farley, O. R. L., Newton, R. U., & Sheppard, J. M. (2017). Maximal Strength Training Improves Surfboard Sprint and Endurance Paddling Performance in Competitive and Recreational Surfers. *Journal of Strength and Conditioning Research*, 31(1), 244-253.
- di Prampero, P. E. (1986). The energy cost of human locomotion on land and in water. *Int J Sports Med*, 7(2), 55-72.
- Ekmecic, V., Jia, N., Cleveland, T. G., Saulino, M., Nessler, J. A., Crocker, G. H., & Newcomer, S. C. (2017). Increasing surfboard volume reduces energy expenditure during paddling. *Ergonomics*, 60(9), 1255-1260.
- Enright, P. L. (2003). The Six-Minute Walk Test. *Respiratory Care*, 48(8), 783.
- Eurich, A. D., Brown, L. E., Coburn, J. W., Noffal, G. J., Nguyen, D., Khamoui, A. V., & Uribe, B. P. (2010). Performance differences between sexes in the pop-up phase of surfing. *The Journal of Strength & Conditioning Research*, 24(10), 2821-2825.
- Eurich, A. D., Brown, L. E., Coburn, J. W., Noffal, G. J., Nguyen, D., Khamoui, A. V., & Uribe, B. P. (2010). Performance Differences between Sexes in the Pop-up Phase of Surfing. *Journal of Strength and Conditioning Research*, 24(10), 2821-2825.
- EuroSIMA. (2014). *Activity Report 2013-2014*. Hossegor - France: EuroSima.
- Everline, C. (2007). Shortboard Performance Surfing: A Qualitative Assessment of Maneuvers and a Sample Periodized Strength and Conditioning Program In and Out of the Water. *Strength & Conditioning Journal*, 29(3), 32-40.
- Farley, O., Harris, N. K., & Kilding, A. E. (2012a). Anaerobic and aerobic fitness profiling of competitive surfers. *J Strength Cond Res*, 26(8), 2243-2248.
- Farley, O. R., Harris, N. K., & Kilding, A. E. (2012). Physiological demands of competitive surfing. *The Journal of Strength & Conditioning Research*, 26(7), 1887-1896.
- Farley, O. R., Harris, N. K., & Kilding, A. E. (2012b). Physiological demands of competitive surfing. *J Strength Cond Res*, 26(7), 1887-1896.

- Farley, O. R., Secomb, J. L., Parsonage, J. R., Lundgren, L. E., Abbiss, C. R., & Sheppard, J. M. (2016). Five Weeks of Sprint and High-Intensity Interval Training Improves Paddling Performance in Adolescent Surfers. *J Strength Cond Res*, *30*(9), 2446-2452.
- Farley, O. R. L., Abbiss, C. R., & Sheppard, J. M. (2016). Performance Analysis Of Surfing: A Review. *Journal of strength and conditioning research/National Strength & Conditioning Association*.
- Farley, O. R. L., Abbiss, C. R., & Sheppard, J. M. (2016). Testing Protocols for Profiling of Surfers' Anaerobic and Aerobic Fitness: A Review. *Strength & Conditioning Journal*, *38*(5).
- Farley, O. R. L., Harris, N. K., & Kilding, A. E. (2012). Anaerobic and aerobic fitness profiling of competitive surfers. *The Journal of Strength & Conditioning Research*, *26*(8), 2243-2248.
- Farley, O. R. L., Harris, N. K., & Kilding, A. E. (2012). Physiological demands of competitive surfing. *The Journal of Strength & Conditioning Research*, *26*(7), 1887-1896.
- Farley, O. R. L., Secomb, J. L., Parsonage, J. R., Lundgren, L. E., Abbiss, C. R., & Sheppard, J. M. (2016). Five Weeks of Sprint and High-Intensity Interval Training Improves Paddling Performance in Adolescent Surfers. *The Journal of Strength & Conditioning Research*, *30*(9), 2446-2452.
- Farley, O. R. L., Secomb, J. L., Raymond, E. R., Lundgren, L. E., Ferrier, B. K., Abbiss, C. R., & Sheppard, J. M. (2018). Workloads of Competitive Surfing: Work-to-Relief Ratios, Surf-Break Demands, and Updated Analysis. *J Strength Cond Res*, *32*(10), 2939-2948.
- Fernandez-Gamboa, I., Yanci, J., Granados, C., & Camara, J. (2017). Comparison of Anthropometry and Lower Limb Power Qualities According to Different Levels and Ranking Position of Competitive Surfers. *J Strength Cond Res*, *31*(8), 2231-2237.
- Fernandez-Gamboa, I., Yanci, J., Granados, C., & Camara, J. (2017). Comparison Of Anthropometry And Lower Limb Power Qualities According To Different Levels And Ranking Position Of Competitive Surfers. *The Journal of Strength & Conditioning Research*.
- Fernandez-Gamboa, I., Yanci, J., Granados, C., Freemyer, B., & Camara, J. (2018). Competition Load Described by Objective and Subjective Methods During a Surfing Championship. *J Strength Cond Res*, *32*(5), 1329-1335.
- Fernandez-Lopez, J. R., Camara, J., Maldonado, S., & Rosique-Gracia, J. (2013). The effect of morphological and functional variables on ranking position of professional junior Basque surfers. *Eur J Sport Sci*, *13*(5), 461-467.
- Ferrier, B., Sheppard, J., Farley, O. R. L., Secomb, J. L., Parsonage, J., Newton, R. U., & Nimphius, S. (2018). Scoring analysis of the men's 2014, 2015 and 2016 world championship tour of surfing: the importance of aerial manoeuvres in competitive surfing. *J Sports Sci*, *36*(19), 2189-2195.
- Forsyth, J. R., de la Harpe, R., Riddiford-Harland, D. L., Whitting, J. W., & Steele, J. R. (2017). Analysis of Scoring of Maneuvers Performed in Elite Men's Professional Surfing Competitions. *Int J Sports Physiol Perform*, *12*(9), 1243-1248.
- Forsyth, J. R., de la Harpe, R., Riddiford-Harland, D. L., Whitting, J. W., & Steele, J. R. (2017). Scoring Analysis of Manoeuvres Performed in Elite Male Professional Surfing Competitions. *International Journal of Sports Physiology and Performance*, 1-20.
- Forsyth, J. R., Riddiford-Harland, D. L., Whitting, J. W., Sheppard, J. M., & Steele, J. R. (2018). Understanding successful and unsuccessful landings of aerial maneuver variations in professional surfing. *Scand J Med Sci Sports*, *28*(5), 1615-1624.
- Frank, M., Zhou, S., Bezerra, P., & Crowley, Z. (2009). Effects of long-term recreational surfing on control of force and posture in older surfers: a preliminary investigation. *Journal of Exercise Science & Fitness*, *7*(1), 31-38.
- Furley, P., Dorr, J., & Loffing, F. (2018). Goofy vs. Regular: Laterality effects in surfing. *Laterality*, *23*(6), 629-642.

- Furness, J., Schram, B., Cottman-Fields, T., Solia, B., & Secomb, J. (2018a). Profiling Shoulder Strength in Competitive Surfers. *Sports (Basel)*, 6(2).
- Furness, J. W., Hing, W. A., Sheppard, J. M., Newcomer, S. C., Schram, B. L., & Climstein, M. (2018). Physiological Profile of Male Competitive and Recreational Surfers. (1533-4287 (Electronic)).
- Furness, J. W., Hing, W. A., Sheppard, J. M., Newcomer, S. C., Schram, B. L., & Climstein, M. (2018b). Physiological Profile of Male Competitive and Recreational Surfers. *J Strength Cond Res*, 32(2), 372-378.
- Global Industry Analysts, I. (2016). Surfing - A global strategic business report. Consult. 28/Feb/2018, 2018, disponível em <http://www.strategy.com/PressMCP-6536.asp>
- Grm, A. (2017). Mathematical Model for riverboat dynamics. *Brodogradnja*, 68(3), 25-35.
- Hammer, R. L., & Loubert, P. V. (2010). Alternative Pop-Up for Surfers with Low Back Pain. *North American journal of sports physical therapy: NAJSPT*, 5(1), 15.
- Harris, D. L., Vila-Concejo, A., Webster, J. M., & Power, H. E. (2015). Spatial variations in wave transformation and sediment entrainment on a coral reef sand apron. *Marine Geology*, 363, 220-229.
- Haskell, W. L., Lee, I.-M., Pate, R. R., Powell, K. E., Blair, S. N., Franklin, B. A., Macera, C. A., Heath, G. W., Thompson, P. D., & Bauman, A. (2007). Physical activity and public health: updated recommendation for adults from the American College of Sports Medicine and the American Heart Association. *Circulation*, 116(9), 1081.
- Hayes, K. C. (1982). Biomechanics of postural control. *Exercise and sport sciences reviews*, 10(1), 363.
- IOC, I. O. C. (2012). *Olympic Legacy*.
- ISA. (2014). International Surfing Association. 2014, disponível em <http://www.isasurf.org/>
- Jaric, S. (2002). Muscle strength testing - Use of Normalisation for Body Size. *Sports Medicine*, 32(10), 615-631.
- Karvonen, J., & Vuorimaa, T. (1988). Heart Rate and Exercise Intensity During Sports Activities. *Sports Medicine*, 5(5), 303-311.
- Khundaqji, H., Samain, E., Climstein, M., Schram, B., Hing, W., & Furness, J. (2018). A Comparison of Aerobic Fitness Testing on a Swim Bench and Treadmill in a Recreational Surfing Cohort: A Pilot Study. *Sports (Basel)*, 6(2).
- Kilduff, L. P., Cook, C. J., & Manning, J. T. (2011). Digit Ratio (2d:4d) and Performance in Male Surfers. *Journal of Strength and Conditioning Research*, 25(11), 3175-3180.
- Kvavilashvili, L., & Ellis, J. (2004). Ecological validity and twenty years of real-life/laboratory controversy in memory research: A critical (and historical) review. *History and Philosophy of Psychology*.
- LaLanne, C. L., Cannady, M. S., Moon, J. F., Taylor, D. L., Nessler, J. A., Crocker, G. H., & Newcomer, S. C. (2016). Characterization of Activity and Cardiovascular Responses During Surfing in Recreational Male Surfers Between the Ages of 18 and 75 Years Old. *J Aging Phys Act*, 25(2), 182-188.
- Lauer, J., Rouard, A. H., & Vilas-Boas, J. P. (2016). Upper limb joint forces and moments during underwater cyclical movements. *Journal of Biomechanics*, 49(14), 3355-3361.
- Lima, A. B. (2006). Concepção, desenvolvimento de resultados e eficiência no treino da técnica em Natação.
- Loturco, I., Barbosa, A. C., Nocentini, R. K., Pereira, L. A., Kobal, R., Kitamura, K., Abad, C., Figueiredo, P., & Nakamura, F. (2016). A correlational analysis of tethered swimming, swim sprint performance and dry-land power assessments. *Int J Sports Med*, 37, 211-218.
- Loveless, D. J., & Minahan, C. (2010a). Two reliable protocols for assessing maximal-paddling performance in surfboard riders. *Journal of sports sciences*, 28(7), 797-803.

- Loveless, D. J., & Minahan, C. (2010b). Peak aerobic power and paddling efficiency in recreational and competitive junior male surfers. *European Journal of Sport Science*, *10*(6), 407-415.
- Lovell, D., Kerr A Fau - Wiegand, A., Wiegand A Fau - Solomon, C., Solomon C Fau - Harvey, L., Harvey L Fau - McLellan, C., & McLellan, C. (2013). The contribution of energy systems during the upper body Wingate anaerobic test. (1715-5312 (Print)).
- Lowdon, B. (1983). Fitness requirements for surfing. *SportsCoach*, *6*, 35–38.
- Lowdon, B., Bedi, J., & Horvath, S. (1989). Specificity of Aerobic fitness testing of surfers. *Aust J Sci Med Sport*, *21*(4), 7-10.
- Lundgren, L. E., Tai, T. T., Nimphius, S., Raymond, E., Secomb, J. L., Farley, O. R. L., Newton, R. U., Steele, J. R., & Sheppard, J. M. (2015a). Development and Evaluation of a Simple, Multifactorial Model Based on Landing Performance to Indicate Injury Risk in Surfing Athletes. *International Journal of Sports Physiology & Performance*, *10*(8), 1029-1035.
- Lundgren, L. E., Tran, T. T., Nimphius, S., Raymond, E., Secomb, J. L., Farley, O. R., Newton, R. U., & Sheppard, J. M. (2015b). Comparison of impact forces, accelerations and ankle range of motion in surfing-related landing tasks. *J Sports Sci*, *34*(11), 1051-1057.
- Ma, S., Rossiter, H. B., Barstow, T. J., Casaburi, R., & Porszasz, J. (2010). Clarifying the equation for modeling of $\dot{V}O_2$ kinetics above the lactate threshold. *Journal of Applied Physiology*, *109*(4), 1283-1284.
- Meir, R. A., Lowdon, B., & Davie, A. J. (1991). Heart rates and estimated energy expenditure during recreational surfing. *The Australian Journal of Science and Medicine in Sport*, *23*(3), 70.
- Meir, R. A., Lowdon, B. J., & Davie, A. J. (1991). Heart rates and estimated energy expenditure during recreational surfing. *The Australian Journal of Science and Medicine in Sport*, *23*(3), 70.
- Mendez-Villanueva, A., & Bishop, D. (2005a). Physiological aspects of surfboard riding performance. *Sports Medicine*, *35*(1), 55-70.
- Mendez-Villanueva, A., Bishop, D., & Hamer, P. (2006). Activity profile of world-class professional surfers during competition: a case study. *J Strength Cond Res*, *20*(3), 477-482.
- Mendez-Villanueva, A., Bishop, D., & Hamer, P. (2006). Activity profile of world-class professional surfers during competition: a case study. *The Journal of Strength & Conditioning Research*, *20*(3), 477-482.
- Mendez-Villanueva, A., Landaluce, J. P., García, B. F., Terrados, N., & Bishop, D. (2010a). Inaccuracy of the HR reserve vs. $\dot{V}O_2$ reserve relationship during prone arm-paddling exercise in surfboard riders. *Journal Of Physiological Anthropology*, *29*(6), 189-195.
- Mendez-Villanueva, A., Landaluce, J. P., García, B. F., Terrados, N., & Bishop, D. (2010a). Inaccuracy of the HR Reserve vs. $\dot{V}O_2$ Reserve relationship during prone arm-paddling exercise in surfboard riders. *Journal Of Physiological Anthropology*, *29*(6), 189-195.
- Mendez-Villanueva, A., Mujika, I., & Bishop, D. (2010b). Variability of Competitive Performance Assessment of Elite Surfboard Riders. *Journal of Strength and Conditioning Research*, *24*(1), 135-139.
- Mendez-Villanueva, A., Perez-Landaluce, J., Bishop, D., Fernandez-Garcia, B., Ortolano, R., Leibar, X., & Terrados, N. (2005b). Upper body aerobic fitness comparison between two groups of competitive surfboard riders. *J Sci Med Sport*, *8*(1), 43-51.
- Minahan, C. L., Pirera, D. J., Sheehan, B., MacDonald, L., & Bellinger, P. M. (2016). Anaerobic Energy Production During Sprint Paddling in Junior Competitive and Recreational Surfers. *International journal of sports physiology and performance*, *11*(6), 810-815.
- Moreira, M., & Peixoto, C. (2014). Qualitative task analysis to enhance sports characterization: a surfing case study. *J Hum Kinet*, *42*, 245-257.
- Moreira, M., & Peixoto, C. (2014). Qualitative Task Analysis to Enhance Sports Characterization: A Surfing Case Study. *Journal of human kinetics*, *42*(1), 245-257.

- Morouço, P., Keskinen, K. L., Vilas-Boas, J. P., & Fernandes, R. J. (2011). Relationship between tethered forces and the four swimming techniques performance. *J Appl Biomech*, *27*(2), 161-169.
- Morouço, P., Lima, A. B., Semblano, P., Fernandes, D., Gonçalves, P., Sousa, F., Fernandes, R., Barbosa, T. M., Velhote, M., & Vilas-Boas, J. P. (2006). Validation of a cable speedometer for butterfly evaluation. *Revista Portuguesa De Ciências do Desporto*, 236-239.
- Morouço, P. G., Vilas-Boas, J. P., & Fernandes, R. J. (2012). Evaluation of adolescent swimmers through a 30-s tethered test. *Pediatric exercise science*, *24*(2), 312.
- Neiva, H., Morouço, P., Silva, A., Marques, M., & Marinho, D. (2011). The Effect Of Warm-up on Tethered Front Crawl Swimming Forces. *Journal of human kinetics*, *29*(Special Issue), 113-119.
- Nessler, J. A., Frazee, T., & Newcomer, S. C. (2017a). The effect of foil on paddling efficiency in a short surfboard. *Sports Engineering*, *21*(1), 11-19.
- Nessler, J. A., Hastings, T., Greer, K., & Newcomer, S. C. (2017b). Wearing an Inflatable Vest Alters Muscle Activation and Trunk Angle While Paddling a Surfboard. *Journal of Applied Biomechanics*, *33*(4), 282-287.
- Nessler, J. A., Silvas, M., Carpenter, S., & Newcomer, S. C. (2015). Wearing a Wetsuit Alters Upper Extremity Motion during Simulated Surfboard Paddling. *Plos One*, *10*(11).
- O'Shea, H., & Moran, A. (2017). Does Motor Simulation Theory Explain the Cognitive Mechanisms Underlying Motor Imagery? A Critical Review. *Frontiers in Human Neuroscience*, *11*, 72.
- Paillard, T., Margnes, E., Portet, M., & Breucq, A. (2011). Postural ability reflects the athletic skill level of surfers. *Eur J Appl Physiol*, *111*(8), 1619-1623.
- Paillard, T., Margnes, E., Portet, M., & Breucq, A. (2011). Postural ability reflects the athletic skill level of surfers. *European journal of applied physiology*, *111*(8), 1619-1623.
- Parsonage, J., Secomb, J., Dowse, R., Ferrier, B., Sheppard, J., & Nimphius, S. (2018). The Assessment of Isometric, Dynamic, and Sports-Specific Upper-Body Strength in Male and Female Competitive Surfers. *Sports (Basel)*, *6*(2).
- Parsonage, J., Secomb, J., Tran, T., Farley, O., Nimphius, S., Lundgren, L., Sheppard, J. M., & Parsonage, M. J. (2016). Gender Differences in Physical Performance Characteristics of Elite Surfers. *Journal of strength and conditioning research/National Strength & Conditioning Association*.
- Parsonage, J., Secomb, J. L., Sheppard, J. M., Ferrier, B. K., Dowse, R. A., & Nimphius, S. (2017a). Upper-Body Strength Measures and Pop-Up Performance of Stronger and Weaker Surfers. *J Strength Cond Res*.
- Parsonage, J. R., Secomb, J. L., Tran, T. T., Farley, O. R. L., Nimphius, S., Lundgren, L., & Sheppard, J. M. (2017b). Gender Differences in Physical Performance Characteristics of Elite Surfers. *Journal of Strength and Conditioning Research*, *31*(9), 2417-2422.
- Pittsinger, R., Kress, J., & Crussemeyer, J. (2017). The Effect of a Single Bout of Surfing on Exercise-Induced Affect. *Int J Exerc Sci*, *10*(7), 989-999.
- Redd, M. J., & Fukuda, D. H. (2016). Utilization of Time Motion Analysis in the Development of Training Programs for Surfing Athletes. *Strength & Conditioning Journal*, *38*(4), 1-8.
- Reis, J. F., Millet, G. P., Bruno, P. M., Vleck, V., & Alves, F. B. (2017). Sex and Exercise Intensity Do Not Influence Oxygen Uptake Kinetics in Submaximal Swimming. *Frontiers in Physiology*, *8*, 72.
- Rochelle, R., & Horvath, S. (1978). Thermoregulation in surfers and nonsurfers immersed in cold water. *Undersea biomedical research*, *5*(4), 377-390.
- Rodgers, M. M., & Cavanagh, P. R. (1984). Glossary of biomechanical terms, concepts, and units. *Physical Therapy*, *64*(12), 1886-1902.

- Sanchis-Moysi, J., Idoate, F., Olmedillas, H., Guadalupe-Grau, A., Alayón, S., Carreras, A., Dorado, C., & Calbet, J. A. L. (2010). The upper extremity of the professional tennis player: muscle volumes, fiber-type distribution and muscle strength. *Scandinavian Journal of Medicine & Science in Sports*, *20*(3), 524-534.
- Secomb, J. L., Farley, O. R. L., Lundgren, L., Tran, T. T., King, A., Nimphius, S., & Sheppard, J. M. (2015). Associations Between the Performance of Scoring Manoeuvres and Lower-Body Strength and Power in Elite Surfers. *International Journal of Sports Science & Coaching*, *10*(5), 911-918.
- Secomb, J. L., Farley, O. R. L., Lundgren, L., Tran, T. T., King, A., Nimphius, S., & Sheppard, J. M. (2015a). Associations Between the Performance of Scoring Manoeuvres and Lower-Body Strength and Power in Elite Surfers. *International Journal of Sports Science & Coaching*, *10*(5), 911-918.
- Secomb, J. L., Nimphius, S., Farley, O. R. L., Lundgren, L., Tran, T. T., & Sheppard, J. M. (2016). Lower-Body Muscle Structure and Jump Performance of Stronger and Weaker Surfing Athletes. *International Journal of Sports Physiology and Performance*, *11*(5), 652-657.
- Secomb, J. L., Sheppard, J. M., & Dascombe, B. J. (2015). Time-Motion Analysis of a 2-Hour Surfing Training Session. *International Journal of Sports Physiology and Performance*, *10*(1), 17-22.
- Secomb, J. L., Sheppard, J. M., & Dascombe, B. J. (2015b). Reductions in Sprint Paddling Ability and Countermovement Jump Performance after Surfing Training. *Journal of Strength and Conditioning Research*, *29*(7), 1937-1942.
- Secomb, J. L., Sheppard, J. M., & Dascombe, B. J. (2015b). Time–Motion Analysis of a 2-Hour Surfing Training Session. *International journal of sports physiology and performance*, *10*(1), 17-22.
- Secomb, J. L., Sheppard, J. M., & Dascombe, B. J. (2015c). Time-motion analysis of a 2-hour surfing training session. *Int J Sports Physiol Perform*, *10*(1), 17-22.
- Sheppard, J. M., McNamara, P., Osborne, M., Andrews, M., Borges, T. O., Walshe, P., & Chapman, D. W. (2012c). Association between anthropometry and upper-body strength qualities with sprint paddling performance in competitive wave surfers. *J Strength Cond Res*, *26*(12), 3345-3348.
- Sheppard, J. M., McNamara, P., Osborne, M., Andrews, M., Borges, T. O., Walshe, P., & Chapman, D. W. (2012c). Association between anthropometry and upper-body strength qualities with sprint paddling performance in competitive wave surfers. *The Journal of Strength & Conditioning Research*, *26*(12), 3345-3348.
- Sheppard, J. M., McNamara, P., Osborne, M., Andrews, M., Oliveira Borges, T., Walshe, P., & Chapman, D. W. (2012). Association between anthropometry and upper-body strength qualities with sprint paddling performance in competitive wave surfers. *J Strength Cond Res*, *26*(12), 3345-3348.
- Sheppard, J. M., Nimphius, S., Haff, G. G., Tran, T. T., Spiteri, T., Brooks, H., Slater, G., & Newton, R. U. (2013a). Development of a Comprehensive Performance-Testing Protocol for Competitive Surfers. *International Journal of Sports Physiology and Performance*, *8*(5), 490-495.
- Sheppard, J. M., Osborne, M., Chapman, D. W., Andrews, M., & McNamara, P. (2013b). Technique Adjustments Influence the Performance of Sprint Paddling in Competitive Male Surfers. *International Journal of Sports Science & Coaching*, *8*(1), 43-51.
- Silva, B., & Clemente, F. M. (2017). Physical performance characteristics between male and female youth surfing athletes. *J Sports Med Phys Fitness*.
- Silva, B., Clemente, F. M., & Martins, F. M. (2018). Associations between functional movement screen scores and performance variables in surf athletes. *Journal of Sports Medicine and Physical Fitness*, *58*(5), 583-590.

- Sinclair, W. H., Leicht, A. S., Eady, T. W., Marshall, N. J., & Woods, C. T. (2017). Identifying the physical and anthropometric qualities explanatory of paddling adolescents. *Journal of Science and Medicine in Sport*.
- Sousa, A., Figueiredo, P., Zamparo, P., Pyne, D. B., Vilas-Boas, J. P., & Fernandes, R. J. (2015). Exercise Modality Effect on Bioenergetical Performance at V O₂max Intensity. *Med Sci Sports Exerc*, 47(8), 1705-1713.
- Sousa, A., Figueiredo, P., Zamparo, P., Vilas-Boas, J. P., & Fernandes, R. J. (2013). Anaerobic alactic energy assessment in middle distance swimming. *European Journal of Applied Physiology*, 113(8), 2153-2158.
- Sousa, A. C., Vilas-Boas, J., P., o., & Fernandes, R. J. (2014). Kinetics and Metabolic Contributions Whilst Swimming at 95, 100, and 105% of the Velocity at. *BioMed Research International*, 2014, 9.
- Souza, P. C., Rocha, M. A., & Nascimento, J. V. (2012). Correlation of the bottom turn technique with the scores attributed in high performance surfing. / Correlação da técnica bottom turn com as notas atribuídas no surf de alto rendimento. *Brazilian Journal of Kineanthropometry & Human Performance*, 14(5), 554-561.
- Statistic Brain, R. I. (2018). Surfing Statistics - Date research was conducted: February 17, 2018. Consult. 28/Fev/2018, 2018, disponível em <https://www.statisticbrain.com/surfing-statistics/>
- Thevelein, X., Daly, D., & Persyn, U. (1984). Measurement of total energy use in the evaluation of competitive swimmers. In: Bachl N, Prakop L, Suckaert R (Eds.). *Urban & Schwarzenberg, Wien*, 668-676.
- Tomlin, D. L., & Wenger, H. A. (2001). The relationship between aerobic fitness and recovery from high intensity intermittent exercise. *Sports Medicine*, 31(1), 1-11.
- Tran, T. T., Lundgren, L., Secomb, J., Farley, O. R., Haff, G. G., Newton, R. U., Nimphius, S., & Sheppard, J. M. (2015a). Development and evaluation of a drop-and-stick method to assess landing skills in various levels of competitive surfers. *Int J Sports Physiol Perform*, 10(3), 396-400.
- Tran, T. T., Lundgren, L., Secomb, J., Farley, O. R., Haff, G. G., Seitz, L. B., Newton, R. U., Nimphius, S., & Sheppard, J. M. (2015b). Comparison of physical capacities between nonselected and selected elite male competitive surfers for the National Junior Team. *Int J Sports Physiol Perform*, 10(2), 178-182.
- Tran, T. T., Nimphius, S., Lundgren, L., Secomb, J., Farley, O. R. L., Gregory Haff, G., Newton, R. U., Brown, L. E., & Sheppard, J. M. (2015). Effects of Unstable and Stable Resistance Training on Strength, Power, and Sensorimotor Abilities in Adolescent Surfers. *International Journal of Sports Science & Coaching*, 10(5), 899-910.
- van Strien, J. (2003). The Dutch handedness questionnaire.
- Wilson, G. W., Özkan-Haller, H. T., Holman, R. A., Haller, M. C., Honegger, D. A., & Chickadel, C. C. (2014). Surf zone bathymetry and circulation predictions via data assimilation of remote sensing observations. *Journal of Geophysical Research: Oceans*, 119(3), 1993-2016.
- Xu, F., & Rhodes, E. C. (1999). Oxygen uptake kinetics during exercise. *Sports Medicine*, 27(5), 313-327.
- Zacca, R., Azevedo, R., Chainok, P., Vilas-Boas, J. P., Castro, F. A. S., Pyne, D. B., & Fernandes, R. J. (2018). Monitoring Age-Group Swimmers Over a Training Macrocycle: Energetics, Technique, and Anthropometrics. *J Strength Cond Res*.
- Zamparo, P., Capelli, C., & Pendergast, D. (2011). Energetics of swimming: a historical perspective. *European Journal of Applied Physiology*, 111(3), 367-378.

Appendix I.

Monitoring of plantar forces and surfboard's movement: alternative to understand the injuries mechanism (full paper).

Daniel Dezan de Bona^{1,2,4}, Maria Arcelina Marques^{2,4}, Márcio Borgonovo-Santos^{3,4}, Miguel Velhote Correia^{4,5}

¹ Federal Institute of Education, Science and Technology of Santa Catarina – Florianópolis, Brazil.

² School of Engineering – Polytechnic of Porto – Porto, Portugal

³ Faculty of Sports - Porto University - Porto, Portugal

⁴ Porto Biomechanics Laboratory (LABIOMEP) – Porto, Portugal.

⁵ Faculty of Engineering - Porto University - Porto, Portugal.

Medical Measurements and Applications (MeMeA), on Proceedings of IEEE International Symposium; Lisbon, Portugal. (2014) 1-8

DOI: 10.1109/MeMeA.2014.6860063

This original paper has been reproduced with kind permission of IEEE.

In reference to IEEE copyrighted material which is used with permission in this thesis, the IEEE does not endorse any of Faculty of Sports – Porto University's products or services. Internal or personal use of this material is permitted. If interested in reprinting/republishing IEEE copyrighted material for advertising or promotional purposes or for creating new collective works for resale or redistribution, please go to:

http://www.ieee.org/publications_standards/publications/rights/rights_link.html to learn how to obtain a License from Rights Link.

Abstract

The concern about injuries in sport are evident due to the implications it carries. To have the knowledge of the mechanisms of injuries is important either to prevent and recovery. This context generates the appropriate scenario to develop an electronic solution to measure dynamically the Center of Pressure (CoP) and surfboard's movement and support the understanding of the mechanisms responsible for the occurrence of injuries. Two matrices composed by 24 force sensors and Inertial Measurement Unit (IMU) controlled by ATMEGA1280 microcontroller were developed. This system was tested using a dynamic protocol using one unstable structure at the bottom of the surfboard. The results have shown that the CoP displacement was largest during the tests that presented great rotation changes. Furthermore, the power oscillations were greater during transition moments. The proposed system is able to measure biomechanical variables dynamically (i.e., force, and surfboard's angle pitch and roll). This report reviews the surf injuries in literature and describes the electronic device used beyond to present the results of the tests performed.

Keywords: Centre of Pressure; surfboard instrumentation; surfing injuries; injuries prevention; remote surfing assessment.

Introduction

Surf has a recent history as a professional sport, dating from the 80's the first professional competitions [1]. The number of practitioners has been increasing on the last decades from about 5 million in 1987, Renneker apud [2], up to 23 million in 2006, EuroSIMA apud [3], and has been practiced either in a recreational or professional way. Like in other action sports, the subject has a high susceptibility to injuries, presenting rates up to 6.6 injuries per 1000 hours in competitive surfing [4]. Furthermore, developing injuries could represent extra monetary expenditures, requiring appropriate treatment and medical monitoring, which in turn can carry a period of immobilization and withdrawal from daily tasks. This is even more significant in professional injuries, where surfers may need a longer recovering period, which may become a concern during a competitive period.

Similarly to other high-performance sports, surfing seems to follow the trend of using technology to improve the perception of variables of interest, and therefore make the difference when critical decisions are needed. The scientific state of the art regarding surf is scarce. The main research areas are physiological behaviour [5-8], paddle and stand-up movements [9, 10] and injuries [4, 11-13]. This last area reveals the existence of some concern among scientists. This context opens the appropriate scenario to develop an electronic solution to measure to which biomechanical variables (i.e., force, accelerations) the surfer's body is subjected, and to support the understanding of the mechanisms responsible for the occurrence of injuries.

II. SURFING AND INJURIES

Injuries are the main cause of surfer absence from competition. The ASP website reports eleven injuries from 2011 to 2012 on professional men's ranking. Apart from that, during the 2013 eleven more injured surfers were registered, leaving them out of at least one event (out of 10 events). The worst reported case is the absence of 8 events [14]. In these reported cases, most surfers developed the injuries during training sessions.

The complex movements that occur during surfing raise questions on the surfer's vulnerability to injuries. Although the most frequent type of injuries is lacerations, ranging from 41 % to 46 % of all surfing injuries [15], there are several injuries related to overextending. Mainly at the professional level, musculoskeletal injuries are a common injury. Knee stress, bad posture, and overextending generate the appropriate scenario for injury to occur. During training sessions, surfers frequently stay 4-5 hours in water thus requiring a good physical condition to support the low temperatures and energy necessary to keep surfing [7, 9]. Nathanson et al. [4] reported that 62 % of surfing injuries occur during wave riding. Although most of them, like shoulder dislocation and shoulder strain that represent 35 % of the total upper body injuries, could be the result of excessive use of the upper body during the paddling phase. This is corroborated by [11] who reported that 28 % of upper body injuries were the result of excessive body torque while performing manoeuvres, and was later confirmed by [9]. Furthermore, [11] states that 13 % of the upper body injuries occurring on the trunk, 43% are on the back and 35 % on the chest wall. Musculoskeletal strain injuries were prevalent, although fractures were related.

On the other hand, injuries on lower extremities (LE) correspond to 37 % of the total acute injuries where foot, knee, and ankle injuries are the most common. Although [11] do not further specify other kinds of foot injuries beyond lacerations, the overuse of plantar flexion and dorsal flexion could be responsible for ankle sprain, as indicated by the ASP [14]. Also, the total LE injuries on foot (75 %) are lacerations. On the other hand, knee injuries such as sprains, meniscus tears, and dislocations represent 70 % of the knee injuries. Furthermore, tube riding accounts for 10 % of all acute injuries. Due to the major manoeuvres listed by [9] and [10], injuries occurrence could be related with the complex movements during wave riding where: by controlling the balance, the surfer is able to change the surfboard's direction and velocity; by rotating the upper body the surfer might control the surfboard's direction; by choosing the feet positions, body movements can be controlled.

Methods

A. Electronic System

To determine feet positioning, a surfboard was instrumented with two matrices composed by 24 force sensors, of which 20 operate on 4.4 N range and the remaining 4 sensors operate on the 110 N of force range. They were placed on the surfboard's deck, as shown in Figure I-1. The force sensors matrices are spaced 52 cm from each other and are connected to the same electronic control circuit which was located near the surfboard's nose. To measure the surfboard's position, an Inertial Measurement Unit (IMU) with five degrees of freedom was used. The IMU gives the information about the acceleration over three axes (X, Y and Z) and about rotation over two axes (X and Y).

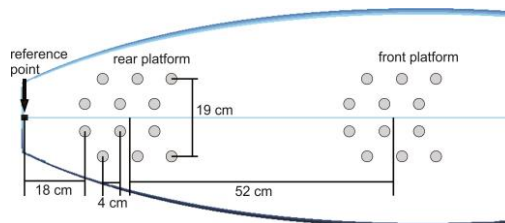

Figure AP I-1. Force sensors distribution on the surfboard.

The force sensors provide information on the pressure distribution exerted by each foot while the IMU provides information about surfboard's accelerations and orientation related to pitch and roll rotation angles.

Data from the sensors was acquired and processed using an ATMEGA1280 microcontroller. This component has embedded an analogue to digital converter (ADC) which converts the voltage from sensors and IMU to digital format. In order to manage the high number of acquisition parameters (29) regarding the few ADC channels available (16), an analogue multiplexer circuit was used, combining 24 force sensor inputs in a cascade circuit. This way, when one of the inputs is connected to the output of the cascade multiplexer circuit, it becomes connected to the ADC. Once the sensor is connected, the difference

between two branches of a Wheatstone bridge represents the differential input of the instrumentation amplifier (IA). Its output is connected to the ADC in order to be read and converted. The IMU signals were also connected to the ADC channels. The data is stored in a micro SD Card and transmitted through WIFI for a remote computer unit. The entire system was assembled on a unique electronic circuit board with 11.1x6.09 cm. The acquisition frequency is established as 10 Hz and transmission baud rate as 115200 bps. The electronic system used is described in more detail in [16].

B. Test Protocol

Both, force sensors and IMU were calibrated to zero orientation corresponding to the ground plane. Positive angles are considered in the clockwise rotation. Surfboard's nose goes down in positive angles while surfboard's tail goes down in negative angles. The instrumented board was positioned on the top of a BOSU® ball, from BOSU® Fitness LLC, providing an unbalanced support for testing, as depicted in Figure I-2. The unbalanced support provided a controlled scenario where different surfer positions can be tested in order to evaluate the sensorial system. The studied movements were performed with the surfer standing-up on the board and controlling rotation about two axes (roll and pitch). During these movements, measurement of the surfboard's rotation angles, the projection of the centre of mass and feet positioning, translated as their CoP, has been performed.

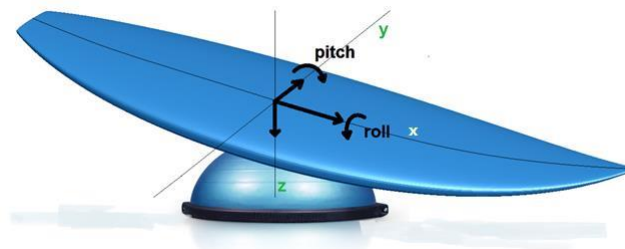

Figure AP I-2. Test setup: surfboard with an unbalanced support.

The tests aim to collect data from surfboard's movement according to the surfer's CoP and provide the information about power along the three proposed tests, mainly observing power [N.m.s^{-1}] transitions moments.

A regular footer subject stands up on the surfboard and executes three movements: (1) Balance test; (2) Pitch rotation test; (3) Roll rotation test - plantar/dorsiflexion sideways displacement. In (1), the subject stays in balance keeping the surfboard parallel to the ground plane. In (2) the subject applies more weight on the back foot moving surfboard's nose up until reaches 30 degrees on pitch axis, keeping that position until the end. In (3) the subject keeps the surfboard parallel to the ground plane moving the surfboard from one side to another along roll axis controlled by plantar/dorsiflexion movement. Five trials were performed with 40 s at 10 Hz each (or 400 samples). After data acquisition, the data was compiled and power was calculated on Microsoft Excel. The moving average (4 window samples) was applied to smooth the graph curves.

To allow a proper auto calibration routine the surfboard is unloaded and the subject is waiting for the command to start. On that moment, the surfboard stays over the BOSU®, inclined about 17 degrees with surfboard's nose touching the ground. The calibration routine ends when the system starts to transmit data over WiFi. After this step, a command to the surfer stands up over the board is given.

Results

A. CoP displacement

TABLE I-1 shows the results of the CoP (X, Y) displacement with the average and standard deviation for each test. On Tests (1) and (3) the average CoP position is near each other and dislocate forward from the geometrical reference (GR), in direction of surfboard's nose, meanwhile, Test (2) shows an average CoP position dislocated backwards from GR in direction of surfboard's tail. Furthermore, Tests (1) and (3) presented higher average values than Test (2) for Y-axis, which suggest that the force was concentrated under the forefoot region on (1) and (3).

Table AP I-1. CoP displacement considering all trials during tests (1), (2) and (3).

| CoP | Tests | | |
|-------|---------------------------|------------------------|-----------------------|
| | (1) Balanced ^a | (2) Pitch ^a | (3) Roll ^a |
| CoP X | 54.80 ± 6.30 | 44.20 ± 11.87 | 54.04 ± 14.70 |
| CoP Y | 12.80 ± 2.03 | 8.90 ± 2.70 | 11.72 ± 5.24 |

^a. Values are expressed in cm.

B. Power Oscillation

For all tests executed, there is an initial transitory which corresponds to stand up moment on the surfboard. Due to an accommodation time, first 5 seconds represents the transitory period. Figure I-3 shows the mean curve for power oscillation over the tests. On Test (1) the power amplitude tends to stabilize after the initial transitory due to the stabilization of the CoP displacement and surfboard's position. Considering the first trial, after the transitory, the power stabilizes about 5.21 ± 0.87 W.

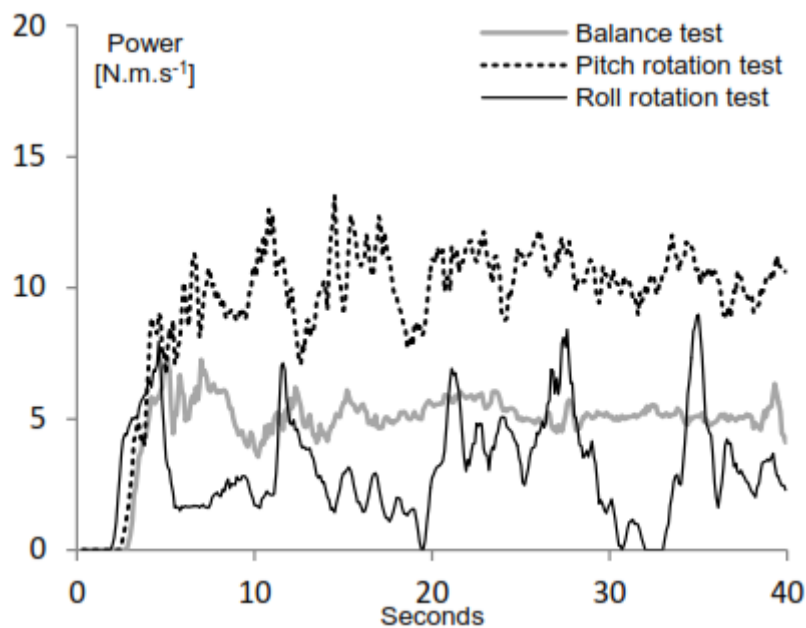

Figure API-3. The mean curves show the Power oscillation related to the respective tests.

On Test (2) is observed a similar stabilization trend after the transitory period on power oscillation, however, there is more oscillation than Test (1) either after the transitory period, with 9.38 ± 3.18 W measured. Figure 3-4 shows the

mean curve of power oscillation and pitch during Test (2). This increase in oscillation after transitory is derived from the challenge of keeping the surfboard's angle stable due to the unbalanced support. It is noticeable that the highest oscillations happen in between 10 to 25 seconds achieving values of 7 to 14 W of power and -34° to -24° of pitch rotation.

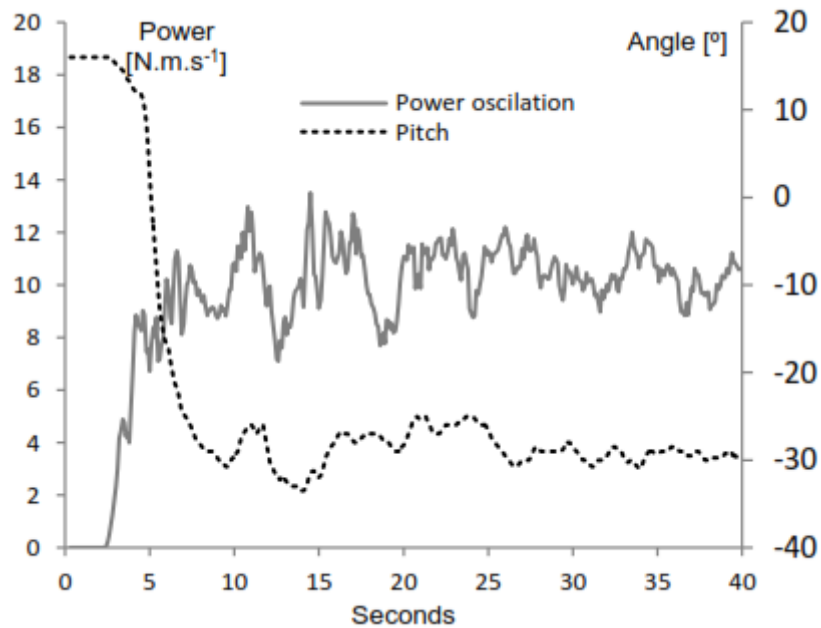

Figure AP I-4. Power oscillation and pitch angle during execution of Test (2).

On Test (3) is observed the highest oscillations where the power is related to CoP displacement and surfboard's roll positioning. Figure 3-5 shows the average curve of power oscillation and roll during Test (3) where is clearly noticeable that either the highest power slopes and power peak amplitude happen during the angle transition.

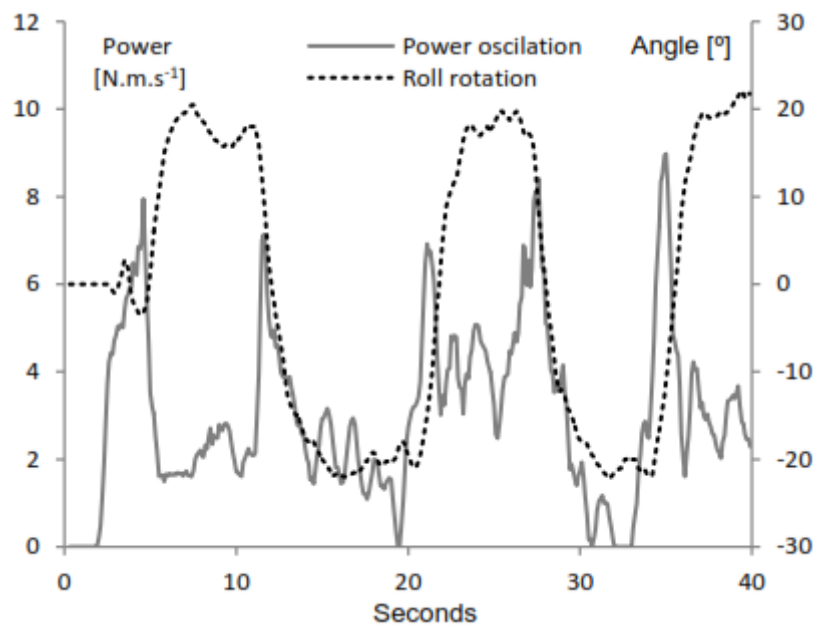

Figure AP I-5. Power oscillation and roll angle during execution of Test (3).

The result has shown that the electronic system is able to measure CoP displacement dynamically. Furthermore, the surfboard's rotation measurement about pitch and roll altogether with CoP allowed estimating the instantaneous power expenditure, providing information about power oscillation. Both can contribute to understanding the mechanisms responsible for the occurrence of injuries, for instance, using one of those approaches described by [17].

Conclusion

Injuries are a concern in the surf practice; therefore the development of an electronic system to monitor biomechanical variables dynamically to support the understanding of injuries' mechanisms is very important and necessary.

The proposed system is able to measure the CoP from individual foot plantar forces and surfboard's pitch and roll angles due to the surfer's movements, as proven by the performed tests results.

The more abrupt transitions in the power can represent either a great variation of the surfboard velocity, or a change in the pressure exerted on the activated sensors, which could mean that more sensors were activated. Crossing

this type of information with the CoP displacement, might allow us to establish some factors to classify movement's instances as intervals with higher or lower probability of injuries occurrence.

The definition of these factors derived from quantitative measurements will largely contribute to injury prevention, mainly in professional surf.

Acknowledgements

The authors would like to acknowledge the Porto Biomechanics Laboratory of University of Porto to providing a complementary environment for testing and validation of this project. Additionally, the SRS Surfboards, represented by Rodrigo Silva, by the partnership and provision of equipment.

References

- [1] Bona, D.D.d., G.d.S. Ferreira, and L. Schwarz. Sensoriamento remoto em pranchas de surfe utilizando tecnologia ZigBee. 2010: IEEE.
- [2] Brasil, F.K., Andrade, D.R., Oliveira, L.C, Ribeiro, M.A. Matsudo, V.K.R, Heart rate and movement time during recreational surfing – pilot study - Frequência cardíaca e tempo de movimento durante o surfe recreacional-estudo piloto, 2001: p. 65.
- [3] Bicudo, P. and A. Horta, Integrating surfing in the socio-economic and morphology and coastal dynamic impacts of the environmental evaluation of coastal projects. *Journal of Coastal Research*, 2009. 56(2): p. 1115-1119.
- [4] Nathanson, A., Bird, S., Dao, L. Tam-Sing, K., Competitive Surfing Injuries A Prospective Study of Surfing-Related Injuries Among Contest Surfers. *The American Journal of Sports Medicine*, 2007. 35(1): p. 113-117.
- [5] Farley, O.R.L., N.K. Harris, and A.E. Kilding, Physiological Demands of Competitive Surfing. *The Journal of Strength & Conditioning Research*, 2012. 26(7): p. 1887-1896.
- [6] Meir, R.A., B.J. Lowdon, and A.J. Davie, Heart rates and estimated energy expenditure during recreational surfing. *Aust J Sci Med Sport*, 1991. 23(3): p. 70-74.
- [7] Mendez-Villanueva, A. and D. Bishop, Physiological aspects of surfboard riding performance. *Sports Medicine*, 2005. 35(1): p. 55-70.
- [8] Mendez-Villanueva, A., D. Bishop, and P. Hamer, Activity Profile of World-Class Professional Surfers During Competition: A Case Study. *The Journal of Strength & Conditioning Research*, 2006. 20(3): p. 477-482.
- [9] Everline, C., Shortboard Performance Surfing: A Qualitative Assessment of Maneuvers and a Sample Periodized Strength and Conditioning Program In and Out of the Water. *Strength & Conditioning Journal*, 2007.29(3): p. 32-40.
- [10] Peirão, R. and S.G.d. Santos, Judging criteria in international professional surfing championships. *Revista Brasileira de Cineantropometria & Desempenho Humano*, 2012. 14(4): p. 439-449.
- [11] Nathanson, A., P. Haynes, and D. Galanis, Surfing injuries. *The American Journal of Emergency Medicine*, 2002. 20(3): p. 155-160.
- [12] Lowdon, B., N. Pateman, and A. Pitman, Surfboard-riding injuries. *The Medical Journal of Australia*, 1983. 2(12): p. 613.
- [13] Taylor, D.M., Bennett, D., Carter, M., Garewall, D., Finch, C.F., Acute injury and chronic disability resulting from surfboard riding. *Journal of science and medicine in sport / Sports Medicine Australia*, 2004. 7(4): p. 429-437.
- [14] Professionals, A.o.S. ASP World Championship Tour Ranking. 2013 [cited 2014/03/01]; Available from: <http://www.aspworldtour.com/rankings/asp-world-championship-tourranking/>.
- [15] Lowdon, B.J., J.D. Patrick, and K. Ross, Manoeuvres Used and Judges' Scores in an International Surfing Contest: Summary Report. 1996: National Sports Research Centre.
- [16] Bona, D.D. and M.A. Marques, Instrumentation of a Surfboard to Evaluate Surfing Performance, in REV2014: 11th International Conference on Remote Engineering and Virtual Instrumentation. 2014, International Association of Online Engineering: Porto, Portugal. p. 5.
- [17] Krosshaug, T., Andersen, T.E., Olsen, O.E. O, Myklebust, G., Bahr, R., Research approaches to describe the mechanisms of injuries in sport: limitations and possibilities. *British Journal of Sports Medicine*, 2005. 39(6): p. 330-339.

Appendix II.

Surf power paddling: velocity and acceleration analysis (conference poster)

Abraldes, J.A.¹, Borgonovo-Santos, M.^{2,3}, Fernandes, R.J.^{2,3}, Vilas-Boas, J.P.^{2,3}, Figueiredo, P.^{2,4}.

¹ University of Murcia, Murcia, Spain

² Centre of Research, Education, Innovation, Intervention in Sport, University of Porto, Porto, Portugal

³ Porto Biomechanics Laboratory, University of Porto, Porto, Portugal

⁴ Physical Education School, Federal University of Rio Grande do Sul, Porto Alegre, Brazil

Cultura, Ciencia y Deporte

Volume 9, Issue 25 SUPPL., 2014, Pages S283

4th International Conference on Human Performance Development through Strength and Conditioning, NSCA 2014; Murcia; Spain; 26 June 2014 through 28 June 2014

Introduction

Surf literature reports, during recreational (1) and professional (2) surf sessions, a proportion of ~50% paddling and ~40% keeping in a stationary position. The power paddling in surf has great importance to enter in the wave with appropriated velocity, to establish a balanced position in the wave lip and in the preparation to execute pop-up manoeuvre to stand up in the surfboard (3). Our objective was to analyze both velocity and acceleration during surf power paddling.

Methods

Five male recreational surfers (34 ± 4 years of age, 81.0 ± 10.0 kg of weight and 1.74 ± 0.5 m of height) that are engaged in surfing practice at least once a week were evaluated in a 25m swimming pool using an electromechanical velocimeter to determine an individual velocity/time curve (50 Hz). The velocimeter line was connected to the central point on the lumbar region of the surfer. After the warm-up, the subjects performed three trials of 10s of power paddling at maximum intensity, without kicking, using their own surfboard (with 5min rest interval).



Figure AP II-1. The left image shows acquisition of velocity signal and the right image shows tests executed in the swimming pool.

Results

The Intraclass correlation coefficient for three trials was 0.97 (CI 95%: 0.96 to 0.97) for velocity and acceleration. Regarding the global performance of the

surfers (10s), it was possible to divide the entire curve in three distinct phases: Incremental (IP), the first 4s, Maintenance (MP), 2s and Fatigue (FP), the last 4s. The values of velocity and acceleration in the different phases were: IP (1.36 ± 0.40 m.s⁻¹, 0.32 ± 0.25 m.s⁻²), MP (1.76 ± 0.04 m.s⁻¹, 0.01 ± 0.02 m.s⁻²) and FP (1.75 ± 0.07 m.s⁻¹, -0.03 ± 0.06 m.s⁻²). Differences were found for the velocity ($F(2, 498)=133.63$, $p<0.001$, effect size 34%) and acceleration ($F(2,498)=254.79$, $p<0.001$, effect size 50%) between phases.

Discussion and Conclusion

The velocity values of our study were similar to the ones found for competitive surfers (3), however, that study did not take into account the different phases of the performance curve. It was possible to observe that on the IP phase 4s were necessary, so that the velocity went to a plateau, and the acceleration maintained positive. In this phase, it is important to observe the rate of acceleration/time (Jerk). In the MP, the velocity remained constant and consequently, the mean acceleration was zero, and it had a mean duration of 2s. The last phase, FP, showed a great variability. Probably this phenomenon can be related to the anaerobic energy system. The results gave new insights on the surf power paddling that should be taken into account in future interventions in surf training, to reach the top velocity faster in IP and attain longer duration in MP.

References

1. Meir. R. A.; Lowdon, B.J.; Davie, A. J.; Heart rates and estimated energy expenditure during recreational surfing. *Aust. J. Sci. Med. Sport* 23:70-74. 1991.
2. Mendez-Villanueva, A.; Bishopp, D.; Hamer P. Activity profile of world-class professional surfers during competition: a case study. *J Strength Cond Res* 20(3): 477-482. 2006.
3. Loveless, D. J.; Minahan, C. Two reliable protocols for assessing maximal-paddling performance in surfboard riders. *Journal of Sports Sciences* 28(7): 797-803. 2010.

Surf Power Paddling: Velocity and Acceleration Analysis

Abraldes, J. A.¹, Borgonovo-Santos, M.^{2,3}, Fernandes, R. J.^{2,3}, Vilas-Boas, J.P.^{2,3}, Figueiredo, P.^{2,4}

¹ Faculty of Sports Sciences, University of Murcia, Murcia, Spain; ² Centre of Research, Education, Innovation, Intervention in Sport, Faculty of Sport, University of Porto, Porto, Portugal. ³ Porto Biomechanics Laboratory, University of Porto, Porto, Portugal; ⁴ Physical Education School, Federal University of Rio Grande do Sul, Porto Alegre, Brazil.

INTRODUCTION

Surf literature reports, during recreational (1) and professional (2) surf sessions, a proportion of ~50% paddling and ~40% keeping in stationary position. The power paddling in surf has great importance to enter in the wave with appropriated velocity, to establish a balanced position in the wave lip and in the preparation to execute pop-up maneuver to stand up in the surfboard (3). Our objective was to analyze both velocity and acceleration during surf power paddling.

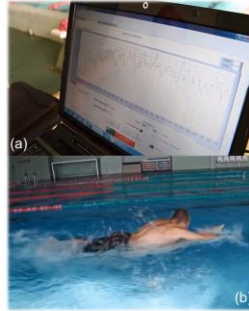

METHODS

Five male recreational surfers (34 ± 4 years of age, 81.0 ± 10.0 kg of weight and 1.74 ± 0.5 m of height) that are engaged in surfing practice at least once a week were evaluated in a 25m swimming pool using an electromechanical velocimeter to determine an individual velocity/time curve (50 Hz). The velocimeter line was connected to the central point on lumbar region of the surfer. After the warm-up, the subjects performed three trials of 10s of power paddling at maximum intensity, without kicking, using their own surfboard (with 5min rest interval).

* a) Acquisition of velocity signal; b) Tests executed in the swimming pool.

RESULTS

The Intraclass correlation coefficient for three trials was 0.97 (CI 95%: 0.96 to 0.97) for velocity and acceleration. Regarding the global performance of the surfers (10s), it was possible to divide the entire curve in three distinct phases: Incremental (IP), the first 4s, Maintenance (MP), 2s and Fatigue (FP), the last 4s. The values of velocity and acceleration in the different phases were: IP (1.36 ± 0.40 m.s⁻¹, 0.32 ± 0.25 m.s⁻²), MP (1.76 ± 0.04 m.s⁻¹, 0.01 ± 0.02 m.s⁻²) and FP (1.75 ± 0.07 m.s⁻¹, -0.03 ± 0.06 m.s⁻²). Differences were found for the velocity ($F(2, 498)=133.63$, $p<0.001$, effect size 34%) and acceleration ($F(2,498)=254.79$, $p<0.001$, effect size 50%) between phases.

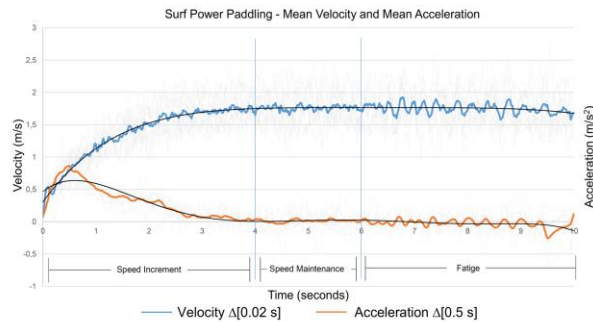

DISCUSSION AND CONCLUSION

The velocity values of our study were similar to the ones found for competitive surfers (3), however that study did not take into account the different phases of the performance curve. It was possible to observe that on the IP phase 4s were necessary, so that the velocity went to a plateau, and the acceleration maintained positive. In this phase it is important to observe the rate of acceleration/time (Jerk). In the MP, the velocity remained constant and consequently the mean acceleration was zero, and it had a mean duration of 2s. The last phase, FP, showed a great variability. Probably this phenomenon can be related to the anaerobic energy system. The results gave new insights on the surf power paddling that should be taken into account in future interventions in surf training, to reach the top velocity faster in IP and attain longer duration in MP.

REFERENCES

1. Meir, R. A.; Lowdon, B.J.; Davie, A. J.; Heart rates and estimated energy expenditure during recreational surfing. *Aust. J. Sci. Med. Sport* 23:70-74. 1991.
2. Mendez-Villanueva, A.; Bishopp, D.; Hamer P. Activity profile of world-class professional surfers during competition: a case study. *J Strength Cond Res* 20(3): 477-482. 2006.
3. Loveless, D. J.; Minahan, C. Two reliable protocols for assessing maximal-paddling performance in surfboard riders. *Journal of Sports Sciences* 28(7): 797-803. 2010.



marcio.borgonovo@gmail.com

Figure AP II-2. Full poster presentation.

Appendix III.

Characterization of surf pop-up simulated movement (conference poster).

Márcio Borgonovo-Santos^{1,2}, Sara Morais², Marcelo Castro³, Pedro Fonseca²,
Pooya Soltani^{1,2}, Andréia Flores², João Paulo Vilas-Boas^{1,2}.

¹ Faculty of Sports – Center of Research Education Innovation and Intervention
in Sport - University of Porto, Porto, Portugal.

² Biomechanics Laboratory of Porto - LABIOMEP, Porto, Portugal.

³ School of Physical Education, Sport and Exercise Science, University of
Otago, Dunedin, New Zealand.

XXV Congress of the International Society of Biomechanics - ISB

Glasgow in July 2015.

Introduction and Objectives

The pop-up is one explosive movement executed to stand up quickly on the surfboard. This movement defines the transition from the horizontal to vertical phase of surfing. After paddling the hands are supported in parallel on the surfboard, under the chest. An extension of the arms is held to promote a strong impulse to take-off, the feet are guided to the back deck and front deck of the surfboard, after that stabilize the body. The pop-up movement separates the successful surf riding or not. Because this is important to understand how this technic works. The main objective of this study is to characterize the pop-up simulated movement on dry land (laboratory conditions). Kinematic analysis was used to explore the best way to divide the movement, and kinetic analysis was used to explore differences between dominant and non-dominant upper and lower limbs.

Methods

The Ethics Committee of the Faculty of Sport from the University of Porto approved this project with the process CEFAD 27-2014. Seven recreational surfers, who practice the activity regularly (age = 31 ± 6 yrs, height = 1.77 ± 0.03 m, mass = 72 ± 9 kg, surf experience = 17 ± 3 yrs, frequency of training = 3 times/week) were evaluated performing a pop-up manoeuvre over force platforms on dry land. This was done on a drawn surfboard layout (6 foot and 2 inches size) over four Bertec force plates (Fig. 1.a.), synchronized with 12 Oqus cameras from the 3D motion capture system (Qualisys AB, Gothenburg, Sweden). Movements were tracked with 48 retro-reflective markers (full body setup) and recorded at 200 Hz. Data analysis was performed with Visual 3D Professional (Visual3D, C-Motion, Kingston, Canada). Forces were normalized according to the subject's body weight. The following outcomes were calculated: upper limbs impulsion peak force percent, lower limbs land peak force percent. Paired T-tests were applied to verify differences between forces applied by the dominant and non-dominant upper limbs, as well as between the lower limbs (front and back on the surfboard).

Results

The movement began when the surfer's hand touched the force plates, the results indicated that the subjects took 1.40 ± 0.52 s to perform the movement (touch the hands on the force plates, stand-up and stabilize). The dominant upper limbs contribute to an impulsion force $50 \pm 6\%$ of the body mass, and the non-dominant limb $49 \pm 5\%$, while both upper limbs exert an impulse force that represents $98 \pm 9\%$ of the body mass. Non-statistical significant differences confirm that the movement was executed in balance ($p=0.43$). The front foot reaches the surfboard with a force that represents $118 \pm 29\%$ of the body mass, and the back foot with $36 \pm 14\%$. When both feet land, they apply a force on the surfboard that represents $153 \pm 35\%$. Statistical significant differences were observed between lower limbs ($p < 0.001$).

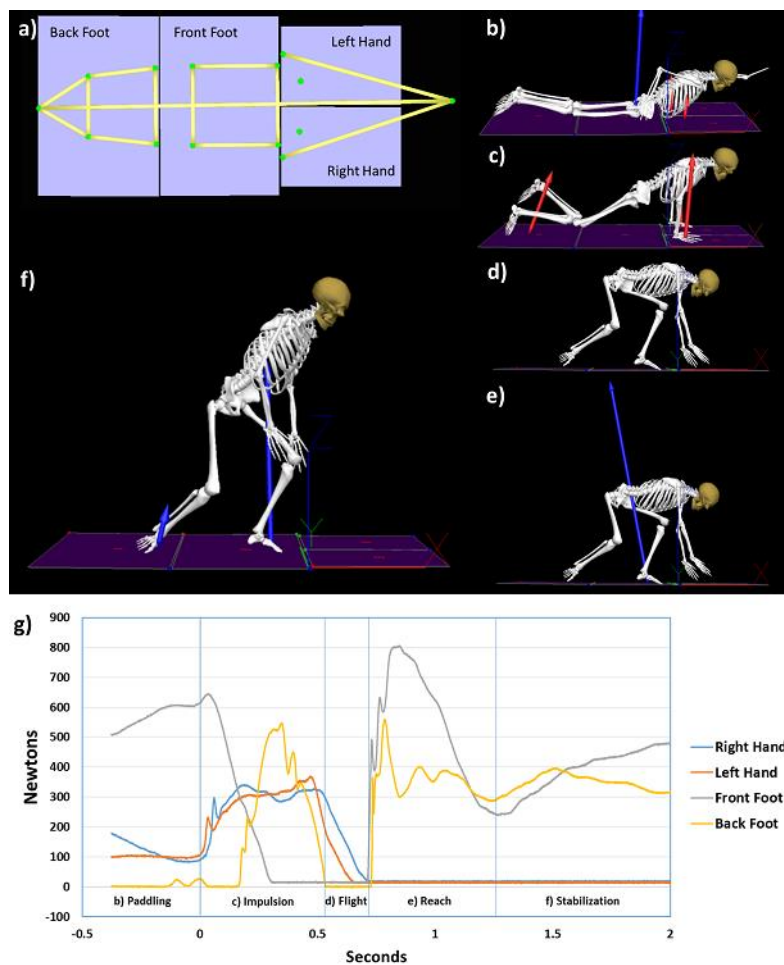

Figure AP III-1. Pop-Up Movement sequence - a) Force plates setup. b) Paddling simulation on the floor. c) Impulsion. d) Flight. e) Reach. f) stabilization. g) Force graph – the contribution of each upper and lower limbs.

Conclusion

It was possible to identify some didactical (Fig. 1.b-f) and analytical (Fig.1.g.) phases of the Pop-Up movement, and analyze the forces in an independent way for each limb of the body, also verify the proportion of the force exerted on the surfboard during this process. The movement was divided in impulsion (Fig 1.c.), flight (Fig. 1.d.), reach (Fig. 1.e.), and stabilization (Fig. 1.f.) phases. We can conclude that the upper limbs need to perform approximately the full body mass of force on the surfboard, to impulse the movement and stand-up. As well, when the body reaches the surfboard, the force applied represents about 150% of the body weight. The force difference between the legs was expected, because when more force is applied on the front deck of the surfboard, the surfer increases their velocity on the wave, while if the force is applied on the back deck the board breaks. The low standard deviation shows values suggest that experienced recreational surfers show a similar way of performing the pop-up.

Acknowledgements

Surf Schools from Matosinhos Portugal (Surf Team Manuel Rui, Surf Aventura, Godzilla Team, and Surf's Cool). This research was supported by CAPES-BRAZIL (BEX 0819/2014).

CHARACTERIZATION OF SURF POP-UP SIMULATED MOVEMENT

Márcio Borgonovo-Santos^{1,2}, Sara Morais², Marcelo Castro³, Pedro Fonseca², Pooya Soltani^{1,2}, Andréia Flores², João Paulo Vilas-Boas^{1,2}

¹Faculty of Sports – Center of Research Education Innovation and Intervention in Sport - University of Porto, Porto, Portugal. ²Biomechanics Laboratory of Porto - LABIOMEPE, Porto, Portugal. ³School of Physical Education, Sport and Exercise Science, University of Otago, Dunedin, New Zealand.

INTRODUCTION AND OBJECTIVES

The pop-up is one explosive movement executed to stand up quickly on the surfboard. This movement defines the transition from the horizontal to vertical phase of surfing. After paddling the hands are supported in parallel on the surfboard, under the chest. An extension of the arms is held to promote a strong impulse to take-off, the feet are guided to the back deck and front deck of the surfboard, after that stabilize the body. The pop-up movement separates the successful surf riding or not. Because this is important to understand how this technic works. The main objective of this study is to characterize the pop-up simulated movement on dry land (laboratory conditions). Kinematic analysis was used to explore the best way to divide the movement, and kinetic analysis was used to explore differences between dominant and non-dominant upper and lower limbs.

METHODS

The Ethics Committee of the Faculty of Sport from the University of Porto approved this project with the process CEFAD 27-2014. Seven recreational surfers, who practice the activity regularly (age = 31±6yrs, height = 1.77±0.03m, mass = 72±9kg, surf experience = 17±3yrs, frequency of training = 3 times/week) were evaluated performing a pop-up maneuver over force platforms on dry land. This was done on a drawn surfboard layout (6 foot and 2 inches size) over four Bertec force plates (Fig. 1.a.), synchronized with 12 Oqus cameras from the 3D motion capture system (Qualisys AB, Gothenburg, Sweden). Movements were tracked with 48 retro-reflective markers (full body setup) and recorded at 200 Hz. Data analysis was performed with Visual 3D Professional (Visual3D, C-Motion, Kingston, Canada). Forces were normalized according to the subject's body weight. The following outcomes were calculated: upper limbs impulsion peak force percent, lower limbs land peak force percent. Paired T-tests were applied to verify differences between forces applied by the dominant and non-dominant upper limbs, as well as between the lower limbs (front and back on the surfboard).

RESULTS

The movement began when the surfer's hand touched the force plates, the results indicated that the subjects took 1.40 ± 0.52 s to perform the movement (touch the hands on the force plates, stand-up and stabilize). The dominant upper limbs contribute to an impulsion force 50 ± 6% of the body mass, and the non-dominant limb 49 ± 5%, while both upper limbs exert a impulse force that represent 98 ± 9% of the body mass. Non-statistical significant differences confirm that the movement was executed in balance (p=0.43). The front foot reaches the surfboard with a force that represent 118 ± 29% of the body mass, and the back foot with 36 ± 14%. When both feet land, they apply a force on the surfboard that represents 153 ± 35%. Statistical significant differences were observed between lower limbs (p < 0.001).

CONCLUSION

It was possible identify some didactical (Fig. 1.b-f) and analytical (Fig.1.g.) phases of the Pop-Up movement, and analyze the forces in an independent way for each limb of the body, also verify the proportion of the force exerted on the surfboard during this process. The movement was divided in impulsion (Fig 1.c.), flight (Fig. 1.d.), reach (Fig. 1.e.), and stabilization (Fig. 1.f.) phases. We can conclude that the upper limbs needs to perform approximately the full body mass of force on the surfboard, to impulse the movement and stand-up. As well, when the body reaches the surfboard, the force applied represents about 150% of the body weight. The force difference between the legs was expected, because when more force is applied on the front deck of the surfboard, the surfer increases their velocity on the wave, while if the force is applied on the back deck the board breaks. The low standard deviation shows values suggest that experienced recreational surfers show a similar way of performing the pop-up.

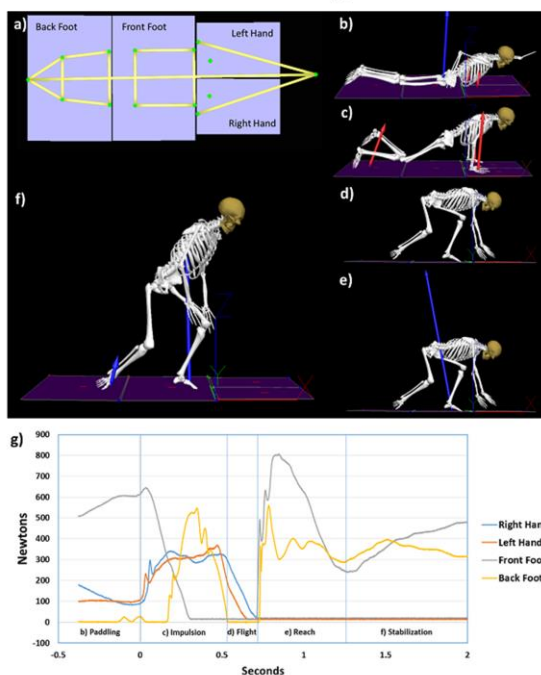

Figure 1. Pop-Up Movement sequence - a) Force plates setup. b) Paddling simulation on the floor. c) Impulsion. d) Flight. e) Reach. f) Stabilization. g) Force graph – contribution of each upper and lower limbs.

ACKNOWLEDGMENTS

Surf Schools from Matosinhos Portugal (Surf Team Manuel Rui, Surf Aventura, Godzilla Team & Surf's Cool). This research was supported by CAPES-BRAZIL (BEX 0819/2014).

marcio.borgonovo@gmail.com



Appendix IV.

Methodology for 3D data analysis of power paddling efficiency in surf (conference presentation).

Márcio Borgonovo-Santos^{1,2}, Pedro Figueiredo^{1,3}, João Paulo Vilas-Boas^{1,2}.

¹ Faculty of Sports – Center of Research Education Innovation and Intervention in Sport - University of Porto, Porto, Portugal.

² Biomechanics Laboratory of Porto - LABIOMEP, Porto, Portugal.

³ Physical Education Faculty, Federal University of Rio Grande do Sul, Porto Alegre, Brazil.

Proceedings of the XVI Brazilian Congress of Biomechanics. Florianópolis: Brazilian Society of Biomechanics, 2015. (Oral presentation).

METHODOLOGY FOR 3D DATA ANALYSIS OF POWER PADDLING EFFICIENCY IN SURF

^{1,2}Márcio Borgonovo-Santos, ^{1,3}Pedro Figueiredo, ^{1,2}João Paulo Vilas-Boas

¹ Faculdade de Desporto - Centro de Investigação Formação Inovação e Intervenção no Desporto, Universidade do Porto, Porto, Portugal.

² Laboratório de Biomecânica do Porto – LABIOMEPE, Porto, Portugal

³ Escola de Educação Física, Universidade Federal do Rio Grande do Sul, Porto Alegre, Brasil



Introduction

Surf has developed significantly as a sport, but the scientific research about the critical aspects for recreational and elite practitioners is still very scarce [1]. The judgment based on visual information and subjective evaluation of the observer, should be reinforced with a quantitative analysis. The objective of this study was to suggest an approach to explore the 3D data, obtained from the maximum power paddling in surf, aiming the creation of criteria to benefit the technique improvement.

Materials and Methods

The Ethics Committee from the Faculty of Sports – University of Porto, approved this project with the process CEFAD 27-2014. Four recreational surfers were evaluated (age = 31 ± 6 yrs, height = 1.77 ± 0.03 m, body mass = 72 ± 9 kg, surf experience = 17 ± 3 yrs, frequency of training = 3 times/week). The subjects performed two all-out 25-m trials at maximal power surf paddling, using

their own surfboard on a 25-m swimming pool. For each trial the first 5.50 s were analysed, assumed to be enough time to analyse the power paddling [2]. The movement was tracked with one reflective marker positioned on the surfboard nose, and recorded at 100 Hz, using 8 Oqus cameras (Qualisys AB, Gothenburg, Sweden). 3D data for Peak Velocity, Distance and Position were extracted from the Qualisys Track Manager Software in X (anterior-posterior), Y (medial-lateral), and Z (vertical) axes. The offset position was normalized removing the difference from the starting point to the 3D origin of the system.

Results and Discussion

Figure AP IV-1a, shows an example of the 3D trajectory variability, where it was possible to analyse the wasted work, this means, and variations in the Y and Z axes. The procedure of decomposition of the trajectory in three-axes helped to evaluate the amount of paddling executions close to the optimal direction. The Y-axis position, demonstrated important information about the useful work to generate velocity efficiently on the X-axis.

Table AP IV-1. Individual 3D values for X Peak Velocity, X Distance.

| Subjects | Trials | XPeakVel (m/s) | | XDis (m) | |
|----------|--------|-------------------|------|-------------|------|
| | | # 1 | # 2 | # 1 | # 2 |
| | | 01 | 1.79 | 1.54 | 5.48 |
| 02 | 1.73 | 1.51 | 5.96 | 5.82 | |
| 03 | 1.45 | 1.65 | 5.31 | 5.35 | |
| 04 | 1.86 | 1.70 | 4.69 | 6.23 | |

Table AP IV-2. Individual 3D values for Y and Z (Range, Standard Deviation and Skewness coefficient) power paddling.

| Subj | Trials | YRange (m) | | YStdDev | | Y Skewness | | ZRange (m) | | ZStdDev | | Z Skewness | |
|------|--------|---------------|------|---------|-------|---------------|-------|---------------|------|---------|-------|---------------|------|
| | | # 1 | # 2 | # 1 | # 2 | # 1 | # 2 | # 1 | # 2 | # 1 | # 2 | # 1 | # 2 |
| | | 01 | 0.17 | 0.24 | 0.04 | 0.07 | -0.18 | -0.13 | 0.11 | 0.12 | 0.03 | 0.03 | 0.28 |
| 02 | 0.24 | 0.46 | 0.06 | 0.11 | -0.37 | 0.33 | 0.09 | 0.13 | 0.02 | 0.03 | -0.08 | -0.73 | |
| 03 | 0.32 | 0.20 | 0.08 | 0.05 | -0.52 | 0.05 | 0.15 | 0.09 | 0.04 | 0.02 | -0.96 | 0.57 | |
| 04 | 0.23 | 0.39 | 0.05 | 0.08 | -0.24 | 0.74 | 0.14 | 0.20 | 0.04 | 0.04 | 0.37 | 1.67 | |

In Table AP IV 1, is possible to observe the relationship between X peak velocity and in Table AP IV 2, the distance with both Y and Z (range, standard

deviation and Skewness coefficient). These information associated with Figure AP III-1b. (box-plot with minimum and maximal values), allows comparing technical adjustments on the power paddling movements.

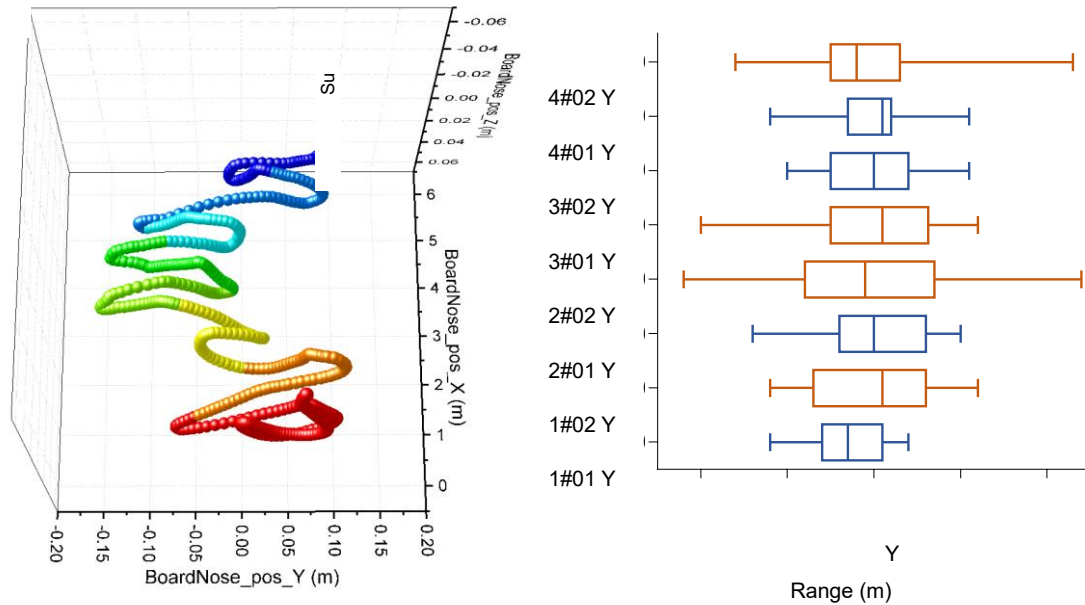

Figure AP IV-1. a) Example of 3D displacement of the surfboard nose during one trial of 5.50 s duration. b) Box-Plots with the entire range of motion, of all subjects, during two trials on the medial-lateral axis (Y). Blue colour represents the best velocity obtained by each subject.

Conclusions

The approach herein presented was sensible to identify surf-paddling technique patterns associated to medial-lateral deviation. In addition, it was possible to observe that the large amplitudes of medial-lateral movements, decreasing efficiency of the paddling, hampered the velocity magnitude.

Acknowledgements

This research was supported by CAPES-BRAZIL (BEX 0819/2014).

References

1. Moreira M, Peixoto C. J Hum Kinet. 42:245-257, 2014.
2. Abraldes JA et al. J Cult, Cien y Dep. 9 (25), 2014.

Appendix V.

Time-motion analysis of competitive bodyboard (conference poster).

Matheus Bacellar Heck^{1,2}, Márcio Borgonovo-Santos^{2,3,4}

¹ Santa Catarina State University – CEFID – Florianópolis, Brazil

² Faculty of Sports – University of Porto – Portugal

³ Porto Biomechanics Laboratory – Portugal

⁴ Surf High Performance Centre – Surf Clube Viana – Viana do Castelo, Portugal

Proceedings of the XVI Brazilian Congress of Biomechanics. Florianópolis: Brazilian Society of Biomechanics, 2015.

Oral presentation.

Young research meeting of Porto University – IJUP2017.

Poster presentation.

Introduction

The practice of bodyboarding has grown rapidly in the last ten years. Championships are becoming more competitive and demanding, making athletes dedicate more time for training (Fig. V-1). This sport is relatively new, and there are many gaps in biomechanical, physiological and physical fitness (1). Time Motion Analysis is a video analysis tool that allows checking the sports actions performed during a session. This tool helps to provide specific information about movement patterns, frequency, average duration, total time and mainly the proportion of activities in time. The main objective of this study is to analyze the sports actions during a bodyboard competition.

Methods

Video camera record of two heats (one bodyboarder per heat) of the Viana World Bodyboard Championship 2016 were analyzed, 50 minutes in total. After recording, the videos were transferred to the V-Note video analysis software. This program allowed to do a detailed analysis of the movement and to observe in detail the events of the world championship of bodyboarding labeling and organizing video segments.

Results

Following the video analysis 53% of the time was spent on paddling, 2% paddling for waves, 2% wave riding, 35% stationary and 6% miscellaneous (Figure V-1).

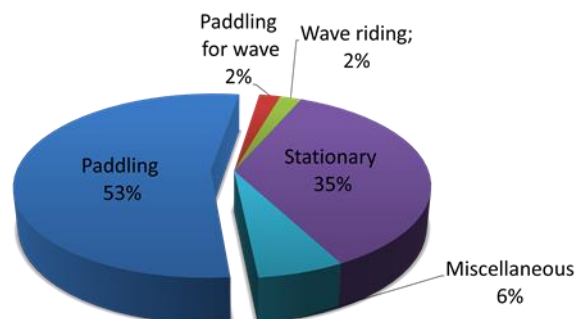

Figure AP V-1. Proportion of activities during a body board contest.

Discussion and Conclusion

The results allow to concluding that to obtain a better competitive performance the athletes must be prepared to resist the great variations of intensity. Only 2% of one heat (wave riding) is considered as criteria for the judgment. Therefore, the remaining 98% related to physical conditioning, should be considered for better bodyboard performance, training, evaluation protocols and predictive models.

Reference

1. Rodríguez-Matoso, D., Mantecón, A., Barbosa-Almeida, E., Valverde, T., García-Manso, JM, & Rodríguez-Ruiz, D.; Mechanical response of knee muscles in high level bodyboarders during performance. Rev. Bras. Med. Esp. (2015)

Time-motion analysis of competitive bodyboard

Matheus Bacellar Heck^{1,2,4}, Márcio Borgonovo-Santos^{2,3,4}

1 - Santa Catarina State University – CEFID – Florianópolis, Brazil

2 - Faculty of Sports – University of Porto – Portugal

3 - Porto Biomechanics Laboratory – Portugal

4 - Surf High Performance Centre – Surf Clube Viana – Viana do Castelo, Portugal

INTRODUCTION

The practice of bodyboarding has grown rapidly in the last ten years. Championships are becoming more competitive and demanding, making athletes dedicate more time for training (Fig. 1). This sport is relatively new, and there are many gaps in biomechanical, physiological and physical fitness (1). Time Motion Analysis is a video analysis tool that allows checking the sports actions performed during a session. This tool helps to provide specific information about movement patterns, frequency, average duration, total time and mainly the proportion of activities in time. The main objective of this study is to analyze the sports actions during a bodyboard competition.

METHODS

Two heats (one bodyboarder per heat) of the Viana World Bodyboard Championship 2016 were analyzed, 50 minutes in total.

RESULTS

Following the video analysis 53% of the time was spent on paddling, 2% paddling for waves, 2% wave riding, 35% stationary and 6% miscellaneous (Chart 1).

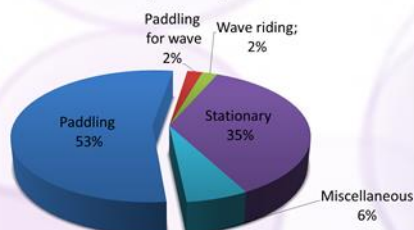

Chart 1. Proportion of activities during a bodyboard contest.



Fig 1. Viana World Bodyboard Championship, athlete performing maneuver in the Mariana beach. (photo by Tó Mané - www.tomanephotos.com)

DISCUSSION AND CONCLUSION

The results allow to concluding that to obtain a better competitive performance the athletes must be prepared to resist the great variations of intensity. Only 2% of one heat (wave riding) is considered as criteria for the judgment. Therefore, the remaining 98% related to physical conditioning, should be considered for better bodyboard performance, training, evaluation protocols and predictive models.

Reference

1. Rodríguez-Matoso, D., Mantecón, A., Barbosa-Almeida, E., Valverde, T., García-Manso, JM, & Rodríguez-Ruiz, D.; Mechanical response of knee muscles in high level bodyboarders during performance. Rev. Bras. Med. Esp. (2015)

Appendix VI. Terra X - ZDF TV Documentary

Information:

<https://www.zdf.de/dokumentation/terra-x/supertalent-mensch-wingsuit-bigwave-bergvolk-strom-100.html>

Super Talent Human, second season

Broadcast ZDF

Film by Birgit Tanner

Editor TV Friederike Haedecke

Editorial Team Online Michael Büsselberg



Figure AP VI-1. Photos that registered the scenes of the documentary.

Appendix VII. Ethical Disclaimer



Ethics Committee

ETHICS OPINION

Process **CEFADE 27.2014**

The Ethics Committee of the Faculty of Sport from the University of Porto analyzed the project entitled “Caracterização biomecânica e bioenergética da fase horizontal do surf: as remadas e movimento para ficar de pé” presented by MSc. Márcio Borgonovo dos Santos. Considering the project’s characteristics, as well as the competence of the research team, the Ethics Committee addresses a positive opinion, because the ethical principles that govern this type of scientific work are respected.

Porto and Faculty of Sport, 24 of September from 2014

The chairman of the Ethics Committee,

José Alberto Ramos Duarte

Appendix VIII. Informed consent – laboratory tests

Termo de Consentimento Livre e Esclarecido

Título do estudo: **Investigação Biomecânica do Surf**
Investigador responsável: **Márcio Borgonovo dos Santos**
Instituição / Departamento: **FADEUP / LABIOMEPE**



Prezado(a) Senhor(a):

- Você está sendo convidado(a) a participar dessa pesquisa de forma totalmente **voluntária**.
- Antes de concordar em participar dessa pesquisa, é muito importante que você compreenda as informações e instruções contidas neste documento.
- Os investigadores deverão responder a todas as suas dúvidas antes de você se decidir a participar.
- Você tem o direito de **desistir** de participar da pesquisa a qualquer momento, sem nenhuma penalidade e sem perder os benefícios aos quais tenha direito.

Objetivo do estudo: *Análise cinemática do movimento de ficar de pé na prancha de surf, realizado em laboratório (em seco).*

Procedimentos: a) Primeiramente os participantes realizarão uma avaliação de bio-impedância. Para isso deverão estar descalços e permanecer em pé, parados, sobre uma balança de bio-impedância. Este exame dura cerca de 3 minutos.

b) Para o segundo procedimento deverão utilizar roupas justas ao corpo. Refletores passivos (esferas) serão fixados na pele (sobre as articulações e pontos anatómicos) com fita dupla face. Após isso, será pedido para que o participante realize 6 execuções válidas do movimento de ficar de pé na prancha, sobre o desenho de uma prancha no solo. A prancha desenhada estará sobre plataformas de forças, que fornecerão dados da força de reação do solo, para os membros utilizados na execução deste movimento. Os marcadores reflexivos servem para registrar em ambiente virtual (computador) o movimento realizado de forma tridimensional.

Benefícios: Será entregue no mesmo dia um relatório demonstrando a distribuição de massa e gordura corporal. Após as análises do movimento de ficar de pé na prancha serem processadas (até 3 meses), serão informados os padrões de técnicas realizadas, bem como as forças de reação do solo.

Riscos: O procedimento realizado nessa investigação é uma simulação em seco do movimento realizado de forma natural e habitual em uma sessão de surf na água incontáveis vezes, portanto estima-se que não exista nenhum risco.

Sigilo: As informações fornecidas por você terão sua privacidade garantida pelos pesquisadores responsáveis. Os sujeitos da pesquisa não serão identificados em nenhum momento, mesmo quando os resultados desta pesquisa forem divulgados em qualquer forma.

Aceitação de participação como sujeito da pesquisa:

Ciente e de acordo com o que foi anteriormente exposto pelo pesquisador, estou de acordo em participar dessa pesquisa, assinando este consentimento. Nome _____, BI: _____.

Porto, ____/____/____

Assinatura do sujeito de pesquisa ou
Representante legal

Márcio Borgonovo dos Santos
Doutorando e Técnico de Investigação

Appendix IX. Informed consent – swimming-pool tests

Termo de Consentimento Livre e Esclarecido

Título do estudo: **Investigação Biomecânica do Surf**
Investigador responsável: **Márcio Borgonovo dos Santos**
Instituição / Departamento: **FADEUP / LABIOMEPE**



Prezado(a) Senhor(a):

- Você está sendo convidado(a) a participar dessa pesquisa de forma totalmente **voluntária**.
- Antes de concordar em participar dessa pesquisa, é muito importante que você compreenda as informações e instruções contidas neste documento.
- Os investigadores deverão responder a todas as suas dúvidas antes de você se decidir a participar.
- Você tem o direito de **desistir** de participar da pesquisa a qualquer momento, sem nenhuma penalidade e sem perder os benefícios aos quais tenha direito.

Objetivo do estudo: *Análise da composição corporal, bioenergética da remada de trânsito em piscina de 25 metros.*

Procedimentos: a) Primeiramente os participantes realizarão uma avaliação de bio-impedância. Para isso deverão estar descalços e permanecer em pé, parados, sobre uma balança de bio-impedância. Este exame dura cerca de 3 minutos. b) Cada participante deverá estar preparado com roupa adequada para piscina e com a sua própria prancha de surf. Será atado na cintura do surfista um tubo elástico (tubo cirúrgico 204), preso por um cinto no nível da cintura, na outra extremidade estará conectado a uma célula de carga para registro das forças de propulsão intracíclicas. Cones do lado de fora, na lateral da piscina indicarão o posicionamento referente ao incremento de carga provido pelo tubo elástico em extensão, espaçamentos referentes a 30 Newtons até o final da piscina. Cada estágio tem duração de 3 minutos. O incremento de força consiste em manter a cabeça próxima ao respectivo cone. O teste será realizado até a identificação de fadiga (a não permanência no cone referente a carga). Ao final de cada estágio o surfista deve regressar para coleta de lactato, repousando no máximo por 30 segundos.

Benefícios: Será entregue no mesmo dia um relatório demonstrando a distribuição de massa muscular e gordura corporal. Após as análises de força e lactato (até 3 meses), serão informados das suas máximas capacidades e comparados com a curva média de todos os participantes. Os resultados serão enviados por correio eletrônico.

Riscos: O procedimento realizado nessa investigação é uma simulação do movimento realizado de forma natural e habitual em uma sessão de surf na água incontáveis vezes, portanto estima-se que não exista nenhum risco. Na eminência de qualquer desconforto o teste será interrompido. O procedimento de coleta de sangue será realizado com luvas cirúrgicas e lancetes descartáveis (novos) por um investigador treinado e habilitado para realizar este procedimento.

Sigilo: As informações fornecidas por você terão sua privacidade garantida pelos pesquisadores responsáveis. Os sujeitos da pesquisa não serão identificados em nenhum momento, mesmo quando os resultados desta pesquisa forem divulgados em qualquer forma.

Aceitação de participação como sujeito da pesquisa:

Ciente e de acordo com o que foi anteriormente exposto pelo pesquisador, estou de acordo em participar dessa pesquisa, assinando este consentimento. Nome _____, BI: _____.

Porto, ____/____/____

Assinatura do sujeito de pesquisa ou
Representante legal

Márcio Borgonovo dos Santos
Doutorando e Técnico de Investigação

Appendix X. Questionnaire – surfer characterization



INFORMAÇÕES DOS PARTICIPANTES DO PROJETO DE BIOMECÂNICA DO SURF

Nome: _____

Data de Nascimento: ____/____/_____.

Sexo: Masculino Feminino

Peso: _____ kg

Altura: _____ cm

| | |
|---|---|
| A quanto tempo pratica surf? _____ | Quantidade de prática: <input type="checkbox"/> 1 a 3 vezes por semana <input type="checkbox"/> 1 a 2 vezes por mês <input type="checkbox"/> Somente no verão |
| Qual o tamanho da prancha que normalmente usa: _____ | Qual pé fica na parte de traseira da prancha, quando de pé? <input type="checkbox"/> Direito (regular) <input type="checkbox"/> Esquerdo (goof) |
| Dominância da Mão: <input type="checkbox"/> Direito <input type="checkbox"/> Esquerdo | Envergadura: _____ cm |
| Tipo de prática de surf: <input type="checkbox"/> Recreacional <input type="checkbox"/> Competidor | |

Appendix XI. Reports – surfer evaluation



RELATÓRIO DA ANÁLISE DA REMADA DE POTÊNCIA NO SURF - VELOCIDADE E FORÇA

Investigador: Márcio Borgonovo dos Santos Data de Avaliação: 10-10-2014

Informações do participante:

Nome: Márcio Borgonovo dos Santos Código de avaliação: FADE01

Idade: 33 anos Peso: 78 kg Altura: 1,83 m

IMC: 23% % Massa Muscular: 64% % Massa Gordura: 12%

IMC - Situação: Saudável * Relação Cintura-Quadril: 0,81 Baixo *
Nível de risco para saúde

Gráfico das velocidades e acelerações das remadas

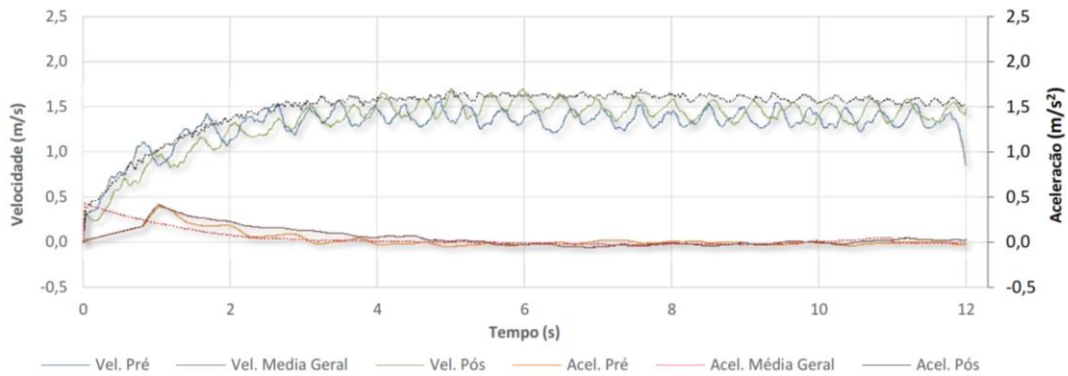

Velocidade Máx Pré: 1,82 m/s Velocidade Média Pré: 1,29 m/s
Velocidade Máx Pós: 1,97 m/s Velocidade Média Pós: 1,33 m/s

Gráfico das forças

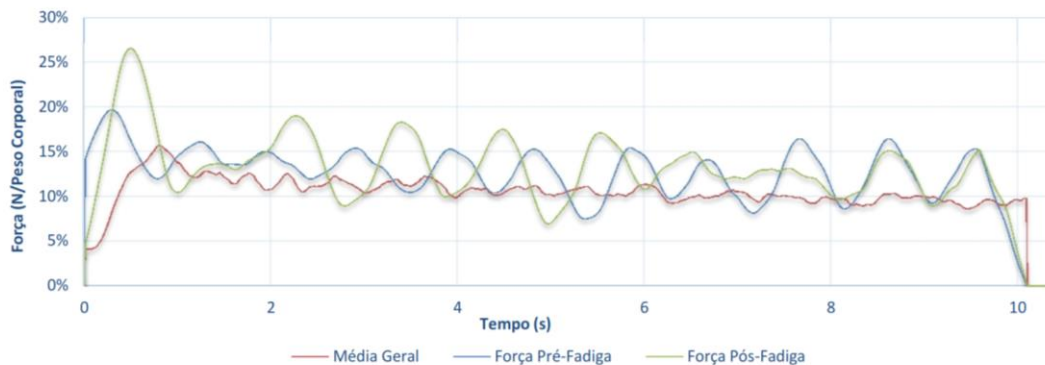

| | | | |
|-------------------|-----------------|-------------------|-----------------|
| Pré Fadiga | | Pós Fadiga | |
| Força Média | <u>99,49 N</u> | Força Média | <u>89,20 N</u> |
| Pico de Força | <u>133,55 N</u> | Pico de Força | <u>132,44 N</u> |
| Força Relativa | <u>17%</u> | Força Relativa | <u>17%</u> |

Obs: Valores das médias gerais provém da base de dados de surfistas do LABIOMEPEP - 2014

* Todas as referências de normalidade estão de acordo com a Organização Mundial de Saúde

RELATÓRIO DA ANÁLISE DA REMADA DE POTÊNCIA NO SURF - DADOS FISIOLÓGICOS

Investigador: Márcio Borgonovo dos Santos

Data de Avaliação: 10-10-2014

Informações do Participante

Nome: Márcio Borgonovo dos Santos

TESTE DE 6 MINUTOS A 60% DA VELOCIDADE MÁXIMA

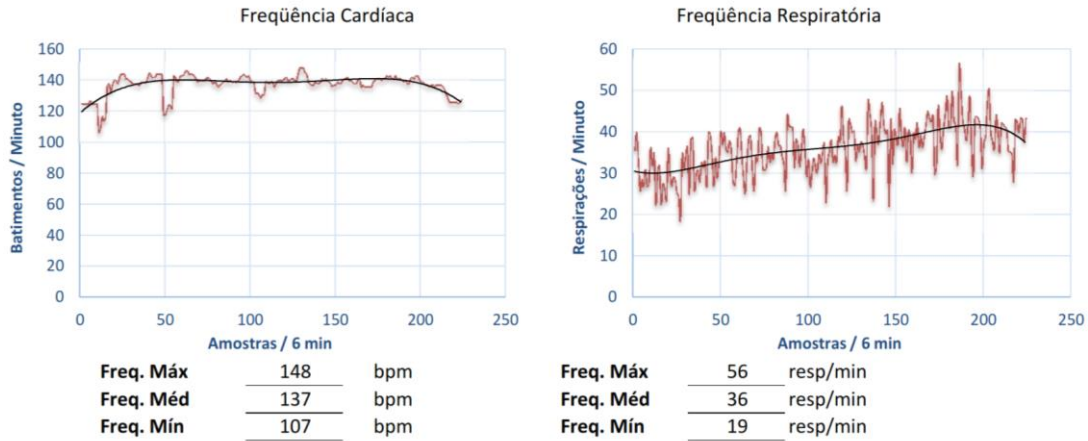

CURVA DE PROGRESSÃO DO VOLUME DE OXIGÊNIO DURANTE O PROTOCOLO DE FADIGA

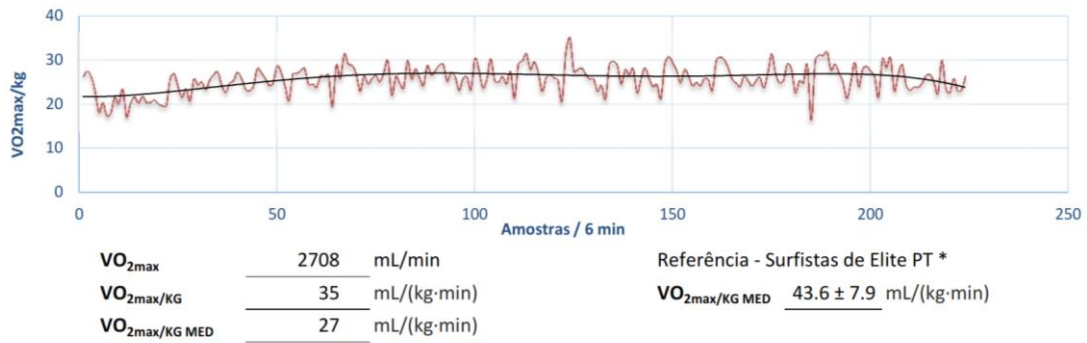

CURVA DE PROGRESSÃO DO LACTATO DURANTE O PROTOCOLO



* Almeida, N. R. C., Variáveis respiratórias e metabólicas no surf : diferenças entre surfistas de elite e surfistas recreativos. (2014)

Fonte: http://www.repository.utl.pt/handle/10400_5/7325

Nome **Márcio Borgonovo dos Santos**
(LB130131112811) | Altura **183,0cm** | 2013/03/13
30,0anos | Sexo **Homem** | 16:56:00

Composição Corporal

| | Abaixo | Normal | Alto | Unidade: % | Faixa normal |
|--|--------------------------|---------------------|--|------------|--------------------------|
| Peso | 55 70 85 100 | 115 130 145 160 175 | | | 62,6 ~ 84,7 |
| | 79,7 kg | | | | |
| MME Massa de Músculo Esquelético | 70 80 90 100 | 110 120 130 140 150 | | | 31,7 ~ 38,7 |
| | 38,8 kg | | | | |
| Massa de Gordura | 40 60 80 100 | 160 220 280 340 400 | | | 8,9 ~ 17,7 |
| | 11,8 kg | | | | |
| A C T Água Corporal Total | 49,7 kg (41,4 ~ 50,6) | | M L G Massa Livre de Gordura | | 67,9 kg (53,8 ~ 67,0) |

Diagnóstico da Obesidade

| | Valores | Faixa normal | |
|---|---------|--------------|---|
| IMC Índice de Massa Corporal (kg/m ²) | 23,8 | 18,5 ~ 25,0 | $IMC = \frac{Peso,kg}{(Altura,m)^2}$ |
| PGC Percentual de Gordura (%) Corporal | 14,8 | 10,0 ~ 20,0 | $PGC = \frac{Gordura,kg}{Peso,kg} \times 100$ |
| RCQ Relação Cintura-Quadril | 0,87 | 0,80 ~ 0,90 | $RCQ = \frac{Circunferência\ do\ cintura,cm}{Circunferência\ do\ quadril,cm}$ |
| TMB Taxa de Metabolismo Basal (kcal) | 1837 | 1687 ~ 1980 | |

Controle Músculo-Gordura

| | | | |
|---------------------|--------|---------------------|--------|
| Controle de músculo | 0,0 kg | Controle de gordura | 0,0 kg |
|---------------------|--------|---------------------|--------|

* Use seus resultados como referência quando for consultar seu médico ou o preparador físico.

Massa magra segmentada

Massa Magra
Avaliação

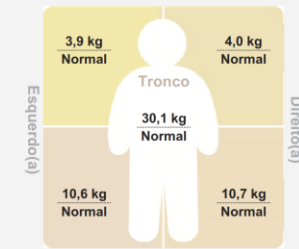

Gordura Segmentada

PGC
Massa de Gordura
Avaliação

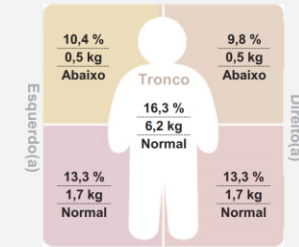

* Gordura Segmentada estimada

Impedância

| Z | BD | BE | TR | PD | PE (Ω) |
|--------|-------|-------|------|-------|--------|
| 20kHz | 293,3 | 300,1 | 23,1 | 258,5 | 265,4 |
| 100kHz | 260,7 | 267,3 | 19,0 | 225,7 | 231,5 |

Plano de Exercícios

Planeje seus exercícios semanais conforme a tabela abaixo e estime sua perda de peso com essas atividades.

| Gasto energético em cada atividade (peso base: 79,7kg /Duração:30 min./unidade:Kcal) | | | | | | | |
|--|-------------------------|--|--|--|---|----------------------------------|---|
| Caminhada 159 | Corrida 279 | Bicicleta 239 | Natação 279 | Alpinismo 260 | Aeróbica 279 | Tênis de mesa 180 | Tênis 239 |
| Futebol 279 | Esgrima Oriental 399 | Gateball 151 | Badminton 180 | Racketball 399 | Taekwon-do 399 | Squash 399 | Basquete 239 |
| Pular corda 279 | Golf 140 | Flexões de braço Desenvolvimento do tronco superior | Abdomina Sit-up Exercícios Abdominais | Treinamento com pesos Prevenção de dores lombares | Exercícios com halteres Força muscular | Banda elástica Força muscular | Agachamento Manutenção dos músculos inferiores |

• Como fazer

- Escolhas as atividades preferidas à esquerda.
- O gasto energético para cada uma é calculado para 30 minutos de exercício.
- Preencha as linhas abaixo com os exercícios para 7 dias.
- Calcule o gasto energético em uma semana.
- Estime a perda total de peso prevista para um mês, usando a fórmula mostrada abaixo.

Cálculo da perda total de peso prevista para 1 mês (4 semanas)

Gasto Energético (Kcal/semana) × 4 semanas ÷ 7700

• Ingestão calórica recomendada por dia.

2400 kcal

Appendix XII. Patent documents



PARECER

Porto, 12 de novembro de 2015

Ref. UPIN NPat.254/2015

Assunto: Comunicação de Invenção "Sensor Fluid 3D"

Inventor Responsável pela Comunicação: Márcio Borgonovo-Santos

Departamento/Faculdade: CIFI2D/ FADEUP – Laboratório de Biomecânica

Exmo. Senhor Reitor,

O gabinete UPIN informa, nos termos do disposto no n.º 1 do art. 13.º do Regulamento de Propriedade Intelectual da Universidade do Porto (RPIUP), que recebeu no passado dia 30 de Setembro de 2015 a comunicação de invenção com o título "Sensor Fluid 3D", melhor identificada em epígrafe.

Depois do exame dos documentos relacionados com a invenção e da análise relativa aos requisitos legais de patenteabilidade da invenção e análise do mercado, é nosso entender que a invenção comunicada merece ser protegida por pedido provisório de patente (PPP).

Para além disso, a empresa "All in Surf", startup incubada no UPTEC - Parque de Ciência e Tecnologia da Universidade do Porto, criada pelos investigadores, está interessada em avaliar o potencial comercial e industrial desta invenção.

O avanço com o PPP em nome da Universidade do Porto asseguraria o direito de prioridade durante 12 meses. O custo associado à proteção por PPP é de 0 € (zero euros).

Com os melhores cumprimentos,

Sofia Messias Varge
UPIN – UNIVERSIDADE DO PORTO INOVAÇÃO
Reitoria da Universidade do Porto

Autorizo a proteção por título de patente
Porto, 16 de novembro de 2015,

O Reitor
Sebastião José Cabral Feyo de Azevedo

| Nº | CÓDIGO | DATA E HORA DE RECEÇÃO | MODALIDADE | PROCESSO RELACIONADO |
|----------------|--------|------------------------|------------|----------------------|
| 20161000030617 | 0198 | 2016/05/09-12:39:51 | PAT | 109368 Z |

PAGAMENTO CONFIRMADO

PEDIDO DE PATENTE, MODELO DE UTILIDADE OU
DE TOPOGRAFIA DE PRODUTOS SEMICONDUTORES

| |
|---|
| 1 REQUERENTE |
| <p>Código 340787 Nacionalidade PORTUGUESA Nome UNIVERSIDADE DO PORTO Endereço PRAÇA GOMES TEIXEIRA, S/N, 4º, S. 463 Localidade PORTO Código Postal 4099-002 Telefone 220 408 077 Telemóvel Fax 220 408 378 E-mail UPIN@REIT.UP.PT Atividade (CAE) NIF</p> |
| 2 MODALIDADE / TIPO DE PEDIDO |
| <p>Modalidade: PEDIDO PROVISÓRIO DE PATENTE Realização de pesquisa pelo INPI: SIM</p> |
| 3 EPÍGRAFE OU TÍTULO |
| <p>SENSOR PARA MEDIÇÃO DA DIREÇÃO, SENTIDO E INTENSIDADE DO FLUXO DINÂMICO DA ÁGUA EM TRÊS DIMENSÕES PARA DESPORTOS NÁUTICOS DE DESLIZE AQUÁTICO</p> |
| 4 RESUMO |
| 5 FIGURAS |
| 6 INVENTORES |
| <p>Nome MÁRCIO BORGONOVO DOS SANTOS Nacionalidade PORTUGUESA Endereço RUA ÓSCAR DA SILVA, 23 1º ANDAR Localidade PORTO Código Postal 4200-433 Telemóvel 926756733 E-mail MARCIO.BORGONOVO@GMAIL.COM NIF 273081543</p> |
| <p>Nome JOSÉ ALBERTO MONTEVERDE LOUREIRO COSTA Nacionalidade PORTUGUESA Endereço PRACETA BERNARDA FERREIRA LACERDA N44 5B Localidade PORTO Código Postal 4200-601 Telemóvel 911597178 E-mail JOSE.COSTA84@GMAIL.COM</p> |

| | |
|--|-------------------------------------|
| NIF 223839434 | |
| Nacionalidade PORTUGUESA | |
| Nome MIGUEL CASTRO ALBUQUERQUE | |
| Endereço RUA PROFESSOR SOUSA JÚNIOR 148 HAB. 44 | |
| Localidade PORTO | Código Postal 4250-478 |
| Telemóvel 913404968 | |
| E-mail MIGUEL.C.ALBQUERQUE@GMAIL.COM | |
| NIF 250364654 | |
| Nacionalidade PORTUGUESA | |
| Nome JOÃO PAULO VILAS-BOAS SOARES CAMPOS | |
| Endereço CAMINHO FONTE DE CIMA , 37. 2º DTO. TR | |
| Localidade PORTO | Código Postal 4150-338 |
| Telemóvel 969021297 | |
| E-mail JPV@FADE.UP.PT | |
| NIF 165643153 | |
| 7 REIVINDICAÇÃO DE PRIORIDADE | |
| 8 DOCUMENTOS ANEXOS | |
| DOCUMENTO DO PEDIDO PROVISÓRIO DE PATENTE (Sensor3D.pdf) FOTOCÓPIA DE BI (CC_Reitor_2015.pdf) FOTOCÓPIA DE BI (Marcio Borgonovo dos Santos.pdf) FOTOCÓPIA DE BI (Jose Costa.pdf) FOTOCÓPIA DE BI (Miguel Albuquerque.pdf) FOTOCÓPIA DE BI (cartao_cidadao_JPVB.pdf) OUTROS (Reitor_Sebastiao_Feyo_Azevedo_PublicacaoHomologacao.pdf) | |
| 9 OBSERVAÇÕES | |
| O Requerente e o INPI acordam em submeter a Tribunal Arbitral eventuais litígios emergentes do presente ato, nos termos e condições especificados em Anexo. Esta cláusula vincula as partes que a subscrevem, apenas podendo ser revogada, por comum acordo, até à pronúncia da decisão arbitral. Autorizo que os meus dados sejam utilizados para efeitos de inquérito sobre a qualidade dos serviços on-line do INPI. Autorizo que os meus dados sejam facultados ao ARBITRARE Centro de Arbitragem para a Propriedade Industrial, Nomes de Domínio, Firmas e Denominações, a fim de que este centro me possa esclarecer e informar sobre os respetivos serviços de mediação e arbitragem. | |
| 10 TAXAS | |
| Taxa | Importância |
| PEDIDO PROVISÓRIO DE PATENTE | 0,00 € |
| PESQUISA EM PEDIDO PROVISÓRIO DE PATENTE | 0,00 € |
| Total: | 0,00 € |
| 11 PAGAMENTO | |
| Tipo de Pagamento | Não aplicável. Requerimento isento. |
| 12 ASSINATURA DO REQUERENTE OU MANDATÁRIO/REPRESENTANTE LEGAL | |
| Assinatura/Nome Sebastião José Cabral Feyo de Azevedo | |
| Nº B.I. 01923121 | Data 2016/05/09 |

20161000030617 - 2016/05/09-12:39:51

2/3

Atenção: Os dados relativos ao nome e morada serão publicados no Boletim da Propriedade Industrial, de acordo com o previsto no Código da Propriedade Industrial, aprovado pelo Decreto-Lei n.º 36/2003, de 5 de Março, ficando também incluídos nas bases de dados de marcas e patentes disponibilizadas neste portal.
Se desejar que a morada não seja conhecida pode optar por indicar um Apartado Postal.
Caso o requerente, poderá também aceder e retificar os seus dados. Para mais informações consulte a política de privacidade deste portal.

20161000030617 - 2016/05/09-12:39:51

3/3

20 MAR 2017

2111-2017

PAT 254

20 MAR 2017

Exmo. Senhor
UNIVERSIDADE DO PORTO
PRAÇA GOMES TEIXEIRA, S/N, 4º, S. 463
4099-002 PORTO

Direção de Marcas e Patentes
Departamento de Patentes e Modelos de Utilidade

| | | |
|-----------------------|--|------------------|
| Ref. DP/01/2017/40787 | PATENTE DE INVENÇÃO NACIONAL n.º 109368 | Data: 2017.03.16 |
|-----------------------|--|------------------|

OFÍCIO

Junto se envia o relatório de pesquisa relativo ao pedido provisório n.º 109368, recebido a 2016.05.09.

Este relatório de pesquisa destina-se a permitir uma primeira avaliação da matéria técnica contida no pedido provisório submetido, através da identificação de estado da técnica divulgado à data do pedido. Este relatório não possui um carácter vinculativo já que a aferição da possível patenteabilidade só poderá ser feita aquando da análise do pedido definitivo em sede de exame da invenção.

Mais se informa que, nos termos n.º 1 do artigo 62.º-B do Código da Propriedade Industrial, para que o presente pedido tenha continuidade, o mesmo deverá ser convertido em pedido definitivo antes de expirado o prazo de 12 meses a contar da data da sua apresentação, acompanhado dos elementos previstos nos artigos 61.º e 62.º devidamente redigidos em Língua Portuguesa. Caso não seja efetuada a conversão, o pedido será considerado retirado, nos termos do n.º 6 do citado artigo.