

# Open Research Online

---

The Open University's repository of research publications and other research outputs

The role of design management as an integrating function in new product development : a model based on high tech companies operating in France.

## Thesis

### How to cite:

Rioche, Laurence (2001). The role of design management as an integrating function in new product development : a model based on high tech companies operating in France. PhD thesis The Open University.

For guidance on citations see [FAQs](#).

© 2001 The Author

Version: Version of Record

---

Copyright and Moral Rights for the articles on this site are retained by the individual authors and/or other copyright owners. For more information on Open Research Online's data [policy](#) on reuse of materials please consult the policies page.

---

[oro.open.ac.uk](http://oro.open.ac.uk)



**THE ROLE OF DESIGN MANAGEMENT AS AN INTEGRATING FUNCTION  
IN NEW PRODUCT DEVELOPMENT:  
A MODEL BASED ON HIGH TECH COMPANIES OPERATING IN FRANCE**

Laurence RIOCHE, MBA

A thesis submitted in partial fulfilment of the requirements of the Open University  
for the degree of Doctor of Philosophy

May 2001

The Open University, United Kingdom

Sponsoring Establishment: Groupe Ecole Supérieure de Commerce de Rennes, France



**A mes parents et à Hervé.**

**A la mémoire de mes grands-parents.**

## **ACKNOWLEDGEMENTS**

I would like to express my sincere appreciation to my Director of Studies, Dr. Laoucine Kerbache, former Dean and Head of Research at ESC Rennes, who has supported me and provided me with precious assistance throughout the whole process of my research studies.

I would also like to thank my second supervisor, Mr Ray Holland, from Brunel University, for his support, advice and encouraging comments. His motivation and enthusiasm with respect to design management have been positively contagious. Moreover, my stay on Runnymede Campus, in January 2001, was a determining step towards completion of the PhD writing process and I sincerely enjoyed the two weeks I spent there.

My gratitude also goes to the managers who contributed to my research during both the quantitative and qualitative stages, and especially Alain Le Hénaff from Acterna (formerly Wandel and Goltermann).

I would also like to express my sincere gratitude to Michel Besnehard, General Director of Groupe ESC Rennes, who has been very supportive and provided me with adequate resources and working conditions to achieve my PhD thesis. My thanks also to the personnel and students of ESC Rennes who have also been encouraging and have contributed to the creation of a pleasant work atmosphere. Special thanks go to the people from the library who have provided me with helpful support as regards literature review.

My warmest thanks and deepest gratefulness also go to my family and to Xavier. My parents have always supported me in my choices and their love has always been a source of motivation. Xavier has also been extremely patient and supportive despite the pressure generated by his own PhD.

Finally, I want to thank all my friends, and especially António, for being who they are.



**The Role of Design Management as an Integrating Function in New Product Development:  
A Model Based on High Tech Companies Operating in France**

Laurence RIOCHE, MBA

The Open University (UK) / Groupe Ecole Supérieure de Commerce de Rennes (France)

**ABSTRACT**

The objective of this dissertation is to analyse the role of design management as an integrating function in new product development (NPD) for the high tech companies operating in France. The first part synthesises existing literature about NPD, high tech organisations, as well as about design. The aim, at this stage, was to gain knowledge about successful NPD and design management strategies. The second part provides a diagnosis of the situation. It is composed of three main studies. The first one is a case study concentrating on NPD in a high tech company, which enabled the researcher to have a concrete approach of the process used and raised issues that laid the foundation of the following exploratory quantitative phase. This survey constitutes the next stage of the primary data collection process, the purpose of which was to gain overall knowledge of the situation. It was completed by a second quantitative survey focusing on NPD and design management issues. These primary data lead to a diagnosis of the current situation which was evaluated against the key factors identified in the literature review. This comparison, based on soft systems methodology, provided guidance to analyse the actions to be taken for efficient design management strategy in high tech organisations and lead to the building of the final model. This model was eventually submitted to a sample of managers in order to ensure applicability in the business environment.

In the final model, top management emerges as the main initiator of the design-oriented strategy and is responsible for implementing an independent design function which intervenes as a facilitator, a co-ordinator and a catalyst that increases cross-functional interfaces during NPD. By intervening in the early stages of the NPD process, design management allows a sharper definition of customers' expectations, reduces iterations and eventually enables the company to launch adapted solutions on the market place. Moreover, it helps to emphasise both product advantages and corporate identity which provides a decisive competitive advantage.



## TABLE OF CONTENTS

Dedication	i
Acknowledgements	ii
Abstract	iii
Table of contents	iv
List of tables	ix
List of figures	xi
List of abbreviations	xiii
<b>Chapter 1: Introduction</b>	<b>1</b>
1.1. Context	1
1.2. Methodology	4
1.2.1. Literature review	4
1.2.2. Primary data collection	5
1.3. New thinking and objectives of research	6
1.4. Outline	6
<b>Chapter 2: Literature review</b>	<b>7</b>
2.1. Introduction	7
2.2. Reactivity has modified the way NPD must be managed	7
2.2.1. Introduction	7
2.2.2. Today's environment requires to be reactive	7
2.2.3. New information technologies	9
2.2.4. Urgency, reactivity and pro-activity	11
2.2.5. New product development	16
2.2.6. NPD and time-to-market	23
2.2.7. Multidisciplinary teams	29
2.2.8. Organising for a shorter product development process, a central role for managers	30
2.3. Synthesis of key elements and conclusions	31



2.4. The characteristics of the high tech environment and the necessity to develop cross-functional interfaces	33
2.4.1. Introduction	33
2.4.2. Defining high technology	34
2.4.3. Marketing in high tech firms	41
2.4.4. Disharmony between R&D and marketing: how to increase integration?	46
2.4.5. Key findings and conclusions	50
2.5. Design and design management	52
2.5.1. Introduction	52
2.5.2. Design in France	52
2.5.3. The wide spectrum of design activities	53
2.5.4. Efficient design management and design strategy	57
2.5.5. The transversal approach versus the traditional linear NPD process	61
2.5.6. Design and visualisation	63
2.5.7. Design and products	64
2.5.8. R&D and design	66
2.5.9. Marketing and design	68
2.5.10. Communication and design	69
2.5.11. Production and design	69
2.5.12. Design and the information system	71
2.5.13. Design and TQM	74
2.5.14. Synthesis of findings and conclusions	75
2.6. General conclusions of literature review	78
<b>Chapter 3: Methodology and SSM</b>	<b>82</b>
3.1. Introduction: overview of the methodological rationale	82
3.2. Methodology	84
3.2.1. The literature review	84
3.2.2. Placement in a high tech organisation	85
3.2.3. Links between literature review, placement and following stages	85
3.2.4. First quantitative stage	86
3.2.5. Second quantitative stage	87



3.2.6. Links between first and second quantitative stages	88
3.2.7. Qualitative stage	88
3.2.8. Overview of methodological process	89
3.3. Soft systems methodology	91
3.3.1. The philosophy of SSM	92
3.3.2. The steps guiding SSM	92
3.3.3. Root definition and CATWOE mnemonic	94
3.3.4. Conceptual model	94
3.3.5. Rich pictures	95
3.3.6. Application of SSM to the research problem	96
3.4. Conclusions	99
<b>Chapter 4: Product development at Wandel &amp; Goltermann</b>	<b>100</b>
4.1. Introduction	100
4.2. Presentation of the group and of the company	100
4.2.1. The group	100
4.2.2. French division	101
4.3. General philosophy as regards NPD	103
4.3.1. Documents relating to NPD at WG France	103
4.3.2. Conclusions	105
4.3.3. Main functions intervening during NPD	106
4.3.4. Conclusions	108
4.4. The NPD process	108
4.4.1. Survey and definition cycle	115
4.4.2. Feasibility cycle	116
4.4.3. Development cycle	117
4.4.4. The pre-launch cycle	119
4.4.5. The launch cycle	121
4.4.6. The sales and demarketing cycle	122
4.4.7. Conclusions	122
4.5. Analysis of overall NPD process at WG France	122
4.5.1. Positive aspects	122



4.5.2. Critical issues	124
4.6. Synthesis of findings and conclusions concerning WG France	133
<b>Chapter 5: Quantitative surveys</b>	<b>136</b>
5.1. Introduction	136
5.2. Exploratory quantitative stage	136
5.2.1. Introduction	136
5.2.2. Methodology and questionnaire	136
5.2.3. Results	138
5.2.4. Synthesis of findings and general conclusions	160
5.3. Second quantitative stage	163
5.3.1. Introduction	163
5.3.2. Methodology and questionnaire	163
5.3.3. Results	165
5.3.4. Synthesis of findings and general conclusions	191
5.4. Synthesis of findings from exploratory stage and second quantitative stage	193
<b>Chapter 6: Model and discussion</b>	<b>194</b>
6.1. Introduction	194
6.2. Methodology	194
6.3. Diagnosis of current situation	195
6.4. The transformation process: from 'input' to 'output'	197
6.5. Final model	198
6.5.1. Factors to be taken into account	198
6.5.2. Final model: actions to be implemented	201
6.6. Conclusions	210
6.6.1. Contribution to new thinking and impact on existing theories	210
6.6.2. Limits of the research	211
6.6.3. Recommendation for further research	213
<b>References</b>	<b>217</b>



<b>Appendices</b>	<b>226</b>
- Appendix 1 WG IBT 5 and IBT 10	226
- Appendix 2: cover letter and exploratory questionnaire in English	228
- Appendix 3: cover letter and second questionnaire in English	249
- Appendix 4: companies contacted for interviews and semi-structured questionnaire	254



## LIST OF TABLES

Table 2.1.	New product strategies	p. 14
Table 2.2.	Financial and non-financial measures	p. 17
Table 2.3.	Fifteen key lessons for new product success	p. 21
Table 2.4.	Manufacturing industries classified according to their technological intensity	p. 37
Table 2.5.	Key design attributes	p. 61
Table 2.6.	The new and old situation for industrial markets	p. 67
Table 3.1.	The CATWOE mnemonic	p. 94
Table 3.2.	CATWOE mnemonic applied to the research problem	p. 96
Table 5.1.	Importance of different sources of innovation	p. 140
Table 5.2.	Types of links between R&D and marketing	p. 143
Table 5.3.	Types of links between R&D and production	p. 144
Table 5.4.	Importance of different functions in R&D decisions	p. 145
Table 5.5.	Types of exchanges between production and marketing	p. 147
Table 5.6.	Priorities concerning NPD	p. 148
Table 5.7.	Importance of different criteria in terms of budget allocated to NPD	p. 150
Table 5.8.	Factors to decide that a new product will be launched	p. 151
Table 5.9.	Factors to reduce NPD delays	p. 152
Table 5.10.	Are there formalised procedures to collect field information?	p. 154
Table 5.11.	Are there formalised procedures to get information from the after sales service?	p. 154
Table 5.12.	Has there been marketing training in the past three years	p. 156
Table 5.13.	People receiving marketing training	p. 156
Table 5.14.	Impact of different factors on product commercial success	p. 158
Table 5.15.	Quality certification / number of people employed	p. 167
Table 5.16.	Collaboration of several departments during NPD	p. 168
Table 5.17.	Collaboration of R&D, production and marketing	p. 169
Table 5.18.	Level of formalism of exchanges between R&D, production and marketing	p.169
Table 5.19.	Formalism of exchanges / formalism of top management during NPD	p.170
Table 5.20.	Multidisciplinary teams / formalism of exchanges between R&D, production and marketing	p. 170
Table 5.21.	Thickness of frontiers between R&D, production and marketing	p. 171
Table 5.22.	Thickness of frontiers between R&D, production and marketing / number of people employed	p. 171
Table 5.23.	Equal participation of R&D, production and marketing in NPD	p. 172
Table 5.24.	Level of formalism of the NPD process	p. 173



Table 5.25.	Formalism of NPD / belong or not to a group	p. 173
Table 5.26.	Formalism of NPD / marketing department in the company	p. 174
Table 5.27.	Quality certification / NPD formalism	p. 175
Table 5.28.	Control from top management during NPD	p. 175
Table 5.29.	Environmental scanning (total sample)	p. 176
Table 5.30.	Environmental scanning (high tech +)	p. 177
Table 5.31.	Environmental scanning (high tech +/-)	p. 177
Table 5.32.	Customers' feedback (total sample)	p. 178
Table 5.33.	Customers' feedback (high tech +)	p. 178
Table 5.34.	Environmental scanning / customers' feedback	p. 179
Table 5.35.	Environmental scanning / marketing department	p. 179
Table 5.36.	Formalism of market follow-up	p. 180
Table 5.37.	Formalism of market follow-up / feedback from customers	p. 180
Table 5.38.	Importance of marketing culture	p. 181
Table 5.39.	Marketing culture / marketing department	p. 181
Table 5.40.	Marketing culture / feedback from customers	p. 182
Table 5.41.	Commercial and advertising efforts	p. 182
Table 5.42.	Design function in the company	p. 183
Table 5.43.	Design function in the group	p. 184
Table 5.44.	Subordination of design to another function	p. 184
Table 5.45.	Departments to which design is subordinated	p. 184
Table 5.46.	Work with external designers	p. 185
Table 5.47.	Importance granted to design (total sample)	p. 185
Table 5.48.	Importance granted to design (high tech +)	p. 186
Table 5.49.	Importance granted to design (high tech +/-)	p. 186
Table 5.50.	Role of design management to develop collaborations between R&D, production and marketing (total sample)	p. 187
Table 5.51.	Role of design management to develop collaborations between R&D, production and marketing (high tech +)	p. 187
Table 5.52.	Role of design management to develop collaborations between R&D, production and marketing (high tech +/-)	p. 187
Table 5.53.	Design to favour collaborations between R&D, production and marketing / belong or not to a group	p. 188
Table 5.54.	Role of design in high tech companies, in general	p. 188
Table 5.55.	Importance of design management / quality certification	p. 189
Table 5.56.	Importance of design / design function in the company	p. 190



Table 5.57.	Importance of design / design to favour collaborations	p. 190
Table 6.1.	'Input' of the SSM model	p. 196
Table 6.2.	The transformation process: from 'input' to 'output'	p. 197

## LIST OF FIGURES

Fig. 2.1.	The urgency paradox	p. 11
Fig. 2.2.	Hierarchy of factors influencing product success	p. 23
Fig. 2.3.	The processing network model	p. 24
Fig. 2.4.	Early introduction can increase sales life and market shares	p. 26
Fig. 2.5.	Early entrants can benefit from the manufacturing learning curve	p. 27
Fig. 2.6.	Long development cycles generate even longer cycles	p. 28
Fig. 2.7.	Efficient NPD in a context of reactivity	p. 33
Fig. 2.8.	The R&D projects continuum	p. 34
Fig. 2.9.	The 'magic triangle' of uncertainties and necessary collaborations	p. 40
Fig. 2.10.	High tech marketing	p. 42
Fig. 2.11.	Managing technological capital	p. 43
Fig. 2.12.	Post-founding factors influencing the success of technology-based companies	p. 44
Fig. 2.13.	The integration gap	p. 47
Fig. 2.14.	How to overcome integration barriers?	p. 48
Fig. 2.15.	Issues relating to NPD in high tech organisations	p. 51
Fig. 2.16.	Developing an industrial design culture-bridge building	p. 60
Fig. 2.17.	Product-related data	p. 64
Fig. 2.18.	Framework for generating user centred information	p. 73
Fig. 2.19.	Impact of design management on the NPD process and necessary adaptations	p. 78
Fig. 2.20.	Synthesis of the key-factors derived from the literature review	p. 81
Fig. 3.1.	Methodological process	p. 89
Fig. 3.2.	The experience-action cycle	p. 91
Fig. 3.3.	The basic shape of SSM	p. 92
Fig. 3.4.	The conventional seven-stage model of SSM	p. 93
Fig. 3.5.	Rich picture	p. 98
Fig. 3.6.	Application of SSM to the methodological process	p. 99
Fig. 4.1.	Structure of WG Group	p. 101
Fig. 4.2.	WG France organisational structure	p. 102
Fig. 4.3.	Overview of product life model or brief guiding plan	p. 110
Fig. 4.4.	Detailed guiding plan from the survey cycle to the sales cycle	p. 111



<b>Fig. 4.5.</b>	<b>From a classical organisation to a multi-functional organisation</b>	<b>p. 128</b>
<b>Fig. 5.1.</b>	<b>Synthesis of findings from quantitative stages</b>	<b>p. 193</b>
<b>Fig. 6.1.</b>	<b>Pictorial representation of transformation process</b>	<b>p. 197</b>
<b>Fig. 6.2.</b>	<b>Actions to implement design management as an integrating function in high tech organisation operating in France</b>	<b>p. 202</b>
<b>Fig. 6.3.</b>	<b>Model expanded to external uncontrollable factors</b>	<b>p. 216</b>



## ABBREVIATIONS

- **AFAQ**: Association Française pour l'Assurance Qualité
- **BVQI**: Bureau Veritas Qualité International
- **CAD**: computer-aided design
- **CPD**: concurrent product development
- **DARPMI**: Direction de l'Action Régionale et de la Petite et Moyenne Industrie
- **DFA**: design for assembly / design for automation
- **ENG**: engineering
- **FCS**: first customer shipment
- **HAS**: human activity systems
- **INSEE**: Institut National des Statistiques et Etudes Economiques
- **ISDN**: integrated services digital networks
- **ISO**: International Standardization Organization
- **M**: milestone
- **MC**: marketing and communication
- **MFC**: manufacturing co-ordinator
- **MM**: marketing manager
- **MPIF**: managers' product introduction file
- **NPD**: new product development
- **OECD**: Organization for Economic Co-operation and Development
- **OST**: Observatoire des Sciences et Techniques
- **PDFA**: product design for assembly
- **PDM**: product data management
- **PJL**: project leader
- **PLC**: product life cycle
- **PME**: product marketing engineer
- **PMM**: product marketing manager
- **PPRS**: preliminary product requirement specifications
- **PQE**: project quality engineer

- **PRS**: product requirement specifications
- **QAM**: quality assurance manager
- **R&D**: research and development
- **SMSFI**: small and medium size French industry
- **SSM**: soft systems methodology
- **TLC**: technology life cycle
- **TQM**: total quality management
- **TTM**: time-to-market
- **UCD**: user-centred design
- **UOD**: user-oriented design



## CHAPTER 1 - INTRODUCTION

### 1.1. Context

In an increasingly competitive and rapidly changing environment, innovation and efficient product development have become of tremendous importance to organisations and the issues relating to the new product development (NPD) challenge have been studied by different researchers (Adler et al., 1996; Cooper, 1994; Hart, 1993; Fujimoto, 1989). The existing literature stresses that revising the NPD process always requires major organisational changes – e.g. structural and cultural adaptations as well as strong managerial implications (Adler et al., 1996; Krehbiel, 1993) -. “Putting new ideas into practice or developing a new product, by definition will necessitate a number of changes which, in order to be effective must be managed successfully” (Trueman, 1998). From the very first predevelopment activities to the final production, everything within the company must be adapted so as to increase the efficiency of NPD management and the adequacy between new products and customers' requirements. However, as stressed by Trueman (1998), there is not one best way to innovate but there are some methods and underlying principles which can increase the chances of success when creating and developing new products.

Moreover, in a context of tough competition, improving the NPD process is also a way of shortening delays. In fact, **reactivity** (Garel, 1994) and, even, **pro-activity** (Walsh et al., 1992) are now key words and there is an increasing pressure towards a shorter product development stage. The implications of such a reduction are numerous: better adaptation to customers' needs, longer product life, more market share, higher margins, elimination of slow competitors, use of very recent techniques, better image, etc. (Garel, 1994). However, the worst way to speed up a company is by trying to make it do things just as it does, only faster (Dumaine, 1989) - i.e. reducing delays must not be detrimental to quality and companies must avoid speeding up the wrong process -. As mentioned by Cooper (1990), the challenge is “to drive new products from idea to market faster and with fewer mistakes”.

Even though the above-mentioned issues strongly impact all the industrial sectors, they induce even more pressure in the field of high tech which has to face a high level of uncertainty (Porter, 1999; Price, 1996; Moriarty and Kosnik., 1989; Millier, 1989). When considering the role of such

sectors in today's economy – the IT sector, for instance, was responsible for 20% of the increase in production between 1994 and 1998 in France (Sessi, 2000) - as well as their intrinsic characteristics, it is essential to carefully consider how NPD must be managed so as to respond to the reactivity challenge.

In fact, among the processes that have been studied in the literature, upstream integration of customers' requirements in the new product development process as well as trans-functional project management and multidisciplinary teams have been emphasised as efficient methods for improving the product development process. However, some researchers have criticised the checklist approach – i.e. literature that only gives a list of things to do in order to improve NPD, without providing any information about how to actually implement them in organisations –. The main argument, here, is that a review of key factors of success is useless in concretely helping the decision-maker and that it is inaccurate to beg the question of cross-functional collaboration throughout the NPD process whereas much literature has stressed the difficulty of implementing and managing such interfaces (Millier, 1997). Even though key factors of success can be identified, they must be accompanied by clear information as regards the way to actually implement and manage them from an organisational as well as from a managerial point of view. Competitiveness will be based on products and markets, but also on processes and **there is an increasing need to focus on processes rather than on products in high tech organisations (Price, 1996).**

Although literature has emphasised the global difficulty of developing a trans-functional approach during NPD, it has also outlined that implementing such processes remains a real challenge for high tech companies due to different factors. First, such sectors are under strong pressure to be first on the market – i.e. acting as 'prospectors' rather than 'reactors' (Miles and Snow, 1978) -. Second, in high tech sectors, market, technical and technological uncertainties reach their highest points (Price, 1990; Moriarty and Kosnik, 1989; Millier, 1989), which increases the difficulty to develop and launch successful products that fit both the demand and corporate resources. Third, technology-oriented cultures which generally dominate in high tech organisations will make it hard to develop a market-driven culture (Thérin, 1996; Viardot, 1994; Monck et al., 1988; Souder, 1981). Thus, management of the NPD process becomes a critical issue. As mentioned by Cohendet et al. (1992) "the delay that must be mastered in priority is the development of new products thanks to a quicker interaction between market requirements and product design".



In such a context, design management, as a strategic and transversal function which bridges market requirements, corporate objectives and final products, may have a role to play as regards NPD in high tech sectors. In fact, **design as a strategic corporate resource** has already been emphasised by different authors (Cegarra and Hetzel, 1997; Revat, 1997; Walker, 1993; Walsh et al., 1992). In France, several studies relating to design were conducted between 1995 and 1998 by the French Ministry of Industry. However, they tended to cover a wide spectrum of aspects and activities. Even though some French authors have explored the decisive role of design management (Briard, 1999; Anselin, 1998; Borja de Mozota, 1993), it has never clearly been emphasised as a **strategic integrating function for the high tech companies operating in France.**

With more than one out of ten industrial companies in France being defined as high or medium-high tech (Sessi, 1997) and when taking into account their weights in today's economy (Chevalier, 2000), **the questions relating to design management applied to sectors with heavy technological inputs require special attention.** This opened the way for the present piece of research.

Thus, on one hand, literature outlines the importance of developing a market orientation and of increasing inter-functional relationships in the quickly expanding high tech sector. On the other hand, design management is presented as a strategic factor which enables to increase interdisciplinary interfaces during NPD and to improve competitiveness thanks to better adaptation to customers' requirements. Even though, as outlined by Roberts (1992), the complexity of analysing the reasons for corporate performance excludes the possibility to develop an "all-encompassing model", the questions that laid the foundations of the research were:

- What is the role that design management could play in high tech organisations operating in France?
- Could design management increase the adequacy between customers' requirements and new products?
- Could design management increase the level of integration between R&D, marketing and production?

- Could it, consequently, improve the efficiency of the NPD process in the high tech sectors?
- Are there differences according to the types of companies concerned – i.e. size, activity, sector, strategic choices, etc. -?
- What kind of organisational and managerial adaptations does the implementation of efficient design management require?

## **1.2. Methodology**

### **1.2.1. Literature review**

At the beginning of the research process, it was necessary to set the overall research framework through literature review. First, research was done relating to the notion of changing environment and necessary reactivity. In fact, the width of today's spectrum of change (Conner, 1992) directly impacts the way NPD must be managed. Thus, research about today's economic environment was followed by a literature review concerning the NPD process, including the methods that have already been identified as enabling to develop successful products and to reduce delays (Wheelwright and Clark, 1995; Smith and Reinersten, 1991). At that stage, it appeared that reducing NPD delays was a real challenge for high tech companies since they are under strong pressure from both their macro and micro environments to innovate at a quick pace. Moreover, strong pressure from uncontrollable factors of the environment (Moriarty and Kosnik, 1989; Millier, 1989) make it essential that the marketing, R&D and production departments co-operate. However, cultures, objectives and priorities often differ between these three functions (Gupta et al., 1986; Souder, 1981). The importance taken by high tech sectors in today's economies open the way to explore new methods to increase the efficiency of NPD through better integration. Among these methods, design management had to be considered as a possible option that could positively impact on NPD efficiency. Thus, secondary data collection was also conducted in this field. The literature review was followed by different stages of primary data collection.



### **1.2.2. Primary data collection**

Four main stages complemented the literature review. First, a one month placement in a telecommunication company lead to gain better understanding of the challenges induced by technology-pushed activities and laid the foundations of the exploratory quantitative survey. This second stage was based on a questionnaire that was mailed to all the high tech companies in France and enabled the researcher to catch the major issues concerning NPD, as well as to narrow the topic. Third, on the basis of the data previously collected, another questionnaire focusing on managerial aspects as well as on R&D, production and marketing interfaces during NPD and integrating questions about design management was developed. The objective at that stage was to collect data about the nature of trans-functional exchanges during NPD and about the perception companies have of the role of design management in such a context.

Following the principles of soft systems methodology (SSM), the information collected was aimed at gaining a deep knowledge of the current situation of the high tech companies operating in France – i.e. the 'real world' - so as to be able to compare it with the state to be reached and to analyse the necessary actions to be taken. These recommendations were integrated in the final model.

Eventually, five managers from high tech companies were contacted to comment on the model, the objective being to confront the findings of the research to the business environment.

### **1.3. New thinking and objectives of research**

Design management as a strategic tool of the firms' development, has quite recently emerged in France (Briard, 1999; Borja de Mozota, 1993) even though it has been emphasised as a determining competitive advantage, especially at the international level (Anselin, 1998). In the field of high tech, where efficient innovation and product development management are strategic weapons, design management may help to improve integration between marketing, technological and technical resources. Moreover, as mentioned by Sorrell (1995), "too few organisations know the true value of effective design".

From a general point of view, the research provides a diagnosis of the management of NPD in high tech organisations operating in France. More specifically, new thinking has emerged from the data collected, leading to the design of a model based on SSM and presenting the actions to be taken so as to emphasise design management as a strategic integrating function throughout the high tech product development process.

#### **1.4. Outline**

The thesis first reviews existing literature as concerns the changes in firms' environment. It then stresses the need for reactivity, especially relating to product development, and more precisely high tech products. At that stage, it insists on the necessary interfaces that should exist between the different internal functions in the NPD process, with special attention to the R&D/marketing/production interfaces. The literature overview is then centred on design management as a strategic managerial tool in new product development. The issues identified in the literature are used as the foundation for the formulation of the primary research. The methodology used for primary data collection is then presented. It is followed by the case study that enabled to gain knowledge about the characteristics of NPD in a heavy technological context. This stage is first complemented by the quantitative results of the exploratory research, and then by the outcomes of a second quantitative survey. These information are integrated in a model which was then validated by a sample of managers whose comments were integrated in the discussion. Eventually, the dissertation presents the limits of the study as well as the routes for further research. The previous steps have lead to the following thesis outline:

- Literature review:
  - reactivity has modified the way NPD must be managed;
  - the characteristics of the high tech environment and the necessity to develop cross-functional interfaces;
  - design and design management.
- Methodology.
- Product development at Wandel and Goltermann.
- Quantitative surveys.
- Model, discussion, limits and recommendations for further research.



## **CHAPTER 2 -LITERATURE REVIEW**

### **2.1. Introduction**

The research topic has led to an investigation in different fields of the existing literature. In fact, the NPD theme covers a wide spectrum of issues which must be addressed so as to understand the reasons why it has become such a challenge in today's economic environment. The first step was to consider the rationale behind the current need for reactivity among business organisations since the pressure for increasing responsiveness and reduced development cycles has justified most of the literature about NPD. This issue is developed in the first part of the literature review. In such a context, it was then necessary to review existing research about NPD. This is done in the second part of this chapter. This is completed by a third part on the characteristics of the high tech business environment, since the research topic focuses on NPD in high tech organisations. Finally, a section is dedicated to design and to its strategic implications, which is a central issue of the present research.

### **2.2. Reactivity has modified the way NPD must be managed**

#### **2.2.1. Introduction**

Modern companies are faced with a quickly changing environment which has directly impacted the way they must be managed. The main objective of this part is to present the reasons for such environmental changes, their characteristics and the necessary adaptations they have required at the organisational level, especially as regards NPD.

#### **2.2.2. Today's environment requires to be reactive**

In order to better understand the need for reactivity, it is necessary to present the characteristics of the current environment in which companies are evolving. In fact, rapidly adapting to an always changing environment is a major challenge of today's economic context. This was developed by different authors (Cooper and Press, 1997; Rochford and Wotruba, 1993; Dumaine, 1989). As mentioned by Conner (1992) "never before has so much changed so fast and with such dramatic

implications for the entire world". However, the reasons that have generated today's turmoil are rarely identified and explained in details.

Conner (1992), supported by other researchers, has focused on several major reasons that explain the width of today's spectrum of change:

- First, faster communication and knowledge acquisition, directly linked to the development of information technologies, have changed the way people communicate world-wide and, thus, have lead to quicker exchanges of ideologies, data, etc. (Trueman, 1998; Urban and Hauser,1993; Conner, 1992).
- A growing world-wide population sharing this information is also a major element in understanding the whole process of necessary reactivity. Figures undoubtedly show that the world's population is growing. This creates increased interdependence and competition but it also generates a wider and heterogeneous demand, which is, thus, more and more difficult to understand. When combined with the first factor - i.e. faster communication and knowledge acquisition - this population growth directly contributes to the spreading of diversified ideologies, which amplifies the heterogeneity of the demand. Moreover, as stressed by Urban and Hauser (1993), lifestyles of industrialised countries have evolved very rapidly since the World War II and have generated permanent consumption changes. Consequently, the complexity of the market makes it more difficult for organisations to provide the right offer.
- Increased interdependence, tougher international competition, a volatile world economy and the emergence of global trade are other inevitable pressures (Trueman, 1998; Urban and Hauser, 1993; Conner, 1992; Porter, 1990), which contributes to increase the necessary level of reactivity and adaptation. For instance, it makes access to distribution channels critical. Moreover, increased competition also combined with faster knowledge acquisition is generating more market awareness. Buyers are increasingly complicated and diverse (Rochford and Wotruba, 1993). Consequently they require greater responsiveness and act as another factor emphasising the necessary reactivity that the firm must adopt. As mentioned by Wheelwright and Clark (1995) "the pressure is on to respond to competitors... immediately".
- Limited resources that must be shared by more and more people, have lead to heavy competition with direct implications from an economic as well as from a political point of view. This was also emphasised by Porter (1999), Trueman (1998), Urban and Hauser (1993) and



Rochford and Wotruba (1993), for whom making the most competitively effective use of the limited resources available is an essential strategic challenge.

- Diversifying political and religious ideologies which, in correlation with other uncontrollable factors of the environment (i.e. political, social, technical variables), enhance the uncertainty of the nature of demand, are also increasing today's level of environmental change.
- Constant transitions of power also require permanent adaptations.
- Finally, new international economic and geopolitical conditions such as the emergence of new industrialised countries and trading blocs constitute new changes to which to adapt (Urban and Hauser, 1993; Rochford and Wotruba, 1993).

The above mentioned factors justify a huge proportion of change when taken separately but the combination of all of them leads to even more change. In Conner's (1992) list of factors explaining change, faster communication ranks first and acts as a catalyst. Ettighoffer and Blanc (1998) also points at new information technologies in order to explain people's new perception of time that the authors call "Chronos' syndrome". Thus, when considering today's necessary reactivity, the changes and improvements that have occurred in information technologies play a major role.

### **2.2.3. New information technologies**

#### **2.2.3.1. Their impact on the economic environment**

New information technologies have a direct impact on our society (Trueman, 1998; Baldwin and Clark, 1997; Conner, 1992). Faster communication, including transportation, exchange of electronic data, etc., means that information as well as goods and people can circulate more quickly. Nowadays, people can rapidly obtain the information they are searching for - e.g. on the WWW -. Consequently, the notion of time and delays is changing. People are getting used to a high level of responsiveness. As customers, they are thus expecting more and more reactivity. In order to face these requirements, companies must focus on their information systems as a central point for scanning their environments, accumulating knowledge about the nature of demand and its evolution, and finally launching the right products or services. Information is now a crucial factor to gain a competitive advantage (Porter and Millar, 1999). Permanent scanning of uncontrollable

factors will enable the organisation to get information that will then be turned into strategic decisions impacting controllable factors - e.g. product marketing mix -.

Since the environment is evolving rapidly, organisations must implement the necessary tools to be constantly aware of the transformations that will affect their micro and macro environments. However, developing, adapting or improving the information system so that it becomes efficiently managed requires organisational changes.

#### **2.2.3.2. New information technologies generate organisational constraints**

Whereas new information technologies have generated new opportunities, they have also transformed the way companies function both internally and as regards their competitive environments (Porter and Millar, 1999). This has caused new maladjustment. With the development of faster communication means, organisations have accelerated their pace of work and have to deal with different tasks at the same time. There are constant parallel flows of information that require punctual validations and lead to a series of quick sequences put end to end. Very often, information systems are not managed as a whole but as a step-by-step process. Consequently, the role of most managers is limited to making punctual decisions and not really to manage the whole organisation with a clear and comprehensive strategy. Changes in information technologies suppose that new organisational strategies are implemented (Ettighoffer and Blanc, 1998; Baile, 1997). In fact, even though they have mainly studied the impact of new information technologies on the management of human resources, a general conclusion of their research is that it obviously changes the way the whole organisation must be structured and managed so as to deal with an increasing level of expected reactivity.

Structural reorganisation, improvement of competitiveness through formalised process, implementation of strategic information systems, customer-oriented strategies, etc. are now critical issues for businesses (Conner, 1992). Faster communication and knowledge acquisition have, thus, impacted on both the whole economic environment of the company and on its internal organisation.



## 2.2.4. Urgency, reactivity and pro-activity

### 2.2.4.1. Urgency

Today's managers are facing a high velocity environment with unprecedented changes in demand, competition and technologies. Consequently, they frequently have to face situations of urgency. In fact, emergency has always existed in business but, according to Riveline (1991), in the past, when innovations were less frequent, it was easier for managers to deal with everyday problems. Moreover, these managers were gaining experience from repetitive decisions and the situation was gradually getting better. Today's emergencies are more dangerous than yesterday's as the environment itself is evolving very quickly. This places a premium on rapid decision-making with a direct impact on the way new product development is managed. As mentioned by Riveline (1991), "emergency is omnipresent in business (...) However, acceleration and overwork are not sufficient for defining emergency. In fact, this notion suggests a lack of time, a state of crisis, a lag between two periods of time: the one we wish we had and the one we effectively have". As outlined by Smith and Reinersten (1991), urgency generally appears once competitors have entered the marketplace, and when companies are under pressure to launch their products rapidly. However, the paradox outlined by the authors, it that it is often too late to benefit from the highest market opportunity (see fig. 2.1.).

Fig. 2.1. - The urgency paradox

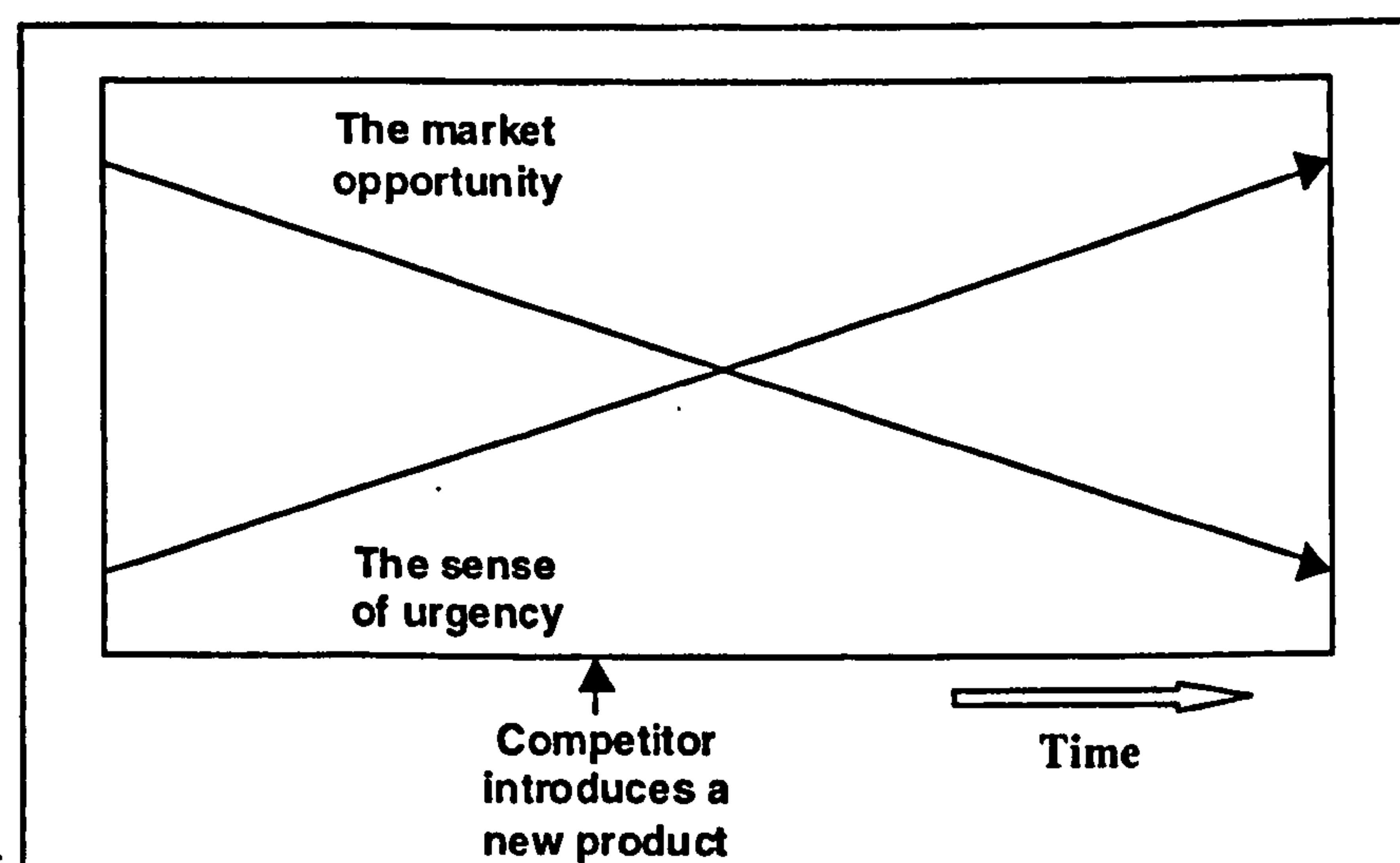

Source: Smith and Reinersten (1991)

Fig. 2.1. stresses the need for anticipation. In this context of urgency, the reactivity model appears as a counterbalance to the pressure of the environment.

#### **2.2.4.2. The reactivity model**

The notions of reactivity and flexibility were studied and developed by different researchers (Garel, 1994; Rochford and Wotruba, 1993; Urban and Hauser, 1993; Cohendet et al., 1992) and are presented as key challenges within the present economic environment. According to Cohendet et al. (1992) reactivity has succeeded to two other production models: the standardisation model (or "Taylorism") and the variety period.

The standardisation/Taylorism period was represented by mass production, clearly compartmentalised functional and manufacturing departments as well as sequential production processes (de Terssac and Dubois, 1992). This was an efficient model in a period of regular growth and quite homogeneous demand. After the standardisation model came the variety model. It appeared when companies realised that there existed different needs in each market, i.e. segments, and when they wanted to get closer to the demand. By adopting a strategy of product differentiation they could consequently serve more markets. However, in both cases, the models were based on regular demand that could be easily predicted. Moreover, there was no direct dependency between the organisational characteristics of the firms and the state of the environment (de Terssac and Dubois, 1992).

On the contrary, the reactivity model implies a strong correlation between the firm's organisational structure and the changes in its environment. As stressed by Rochford and Wotruba (1993) and by Porter and Van Der Linde (1995), companies must constantly react and adapt to different kinds of pressure, as they evolve in a context of active competition and "not in the static world of much economic theory". An innovation directly impacts the market and the different actors intervening on this market. Consequently, most managers will spend a large portion of their time to understand competitors' strategies. However, when the nature of innovation is known it is often too late for the innovation to be exploitable. It consequently leads to other innovations and late companies always remain followers (Stalk et al., 1992). Winning companies efficiently use time. They offer a large variety of products and services with reduced costs and delivery delays.



Focusing on quick response to the market evolution is a major factor of success. Moreover, in certain cases, it enables companies to sell at higher prices, justified by a better level of innovation. Investments made to be more responsive are thus financed by higher margins. However, as shown in table 2.1., reactive strategies can take different forms (Urban and Hauser, 1993). They can be defensive, the main objective in that case being to limit competitors' success by aggressively protecting existing products. But firms can also decide to be imitative, by launching 'me-too' products. They can also choose to use competitors' innovations to improve their existing ranges and thus being "second but better". Finally, reactive strategies can be responsive – i.e. innovations in that case are based on customers' formulated requests -.

However, a distinction must be made between reactivity, which supposes that the firm adapt to increasing pressures from its environment (mainly from competitors and customers), and pro-activity, a situation in which firms actually make the first move towards innovation.

#### **2.2.4.3. Pro-activity**

According to Cohendet et al. (1992), "the firm must be both reactive and pro-active. Thus, the delay that must be managed in priority is the development of new products thanks to a quicker interaction between market requirements and product design". The notion of pro-activity goes even further than mere reactivity. Being able to adapt to a changing environment is vital. Companies that can efficiently anticipate the evolution of the market place and initiate change gain a considerable competitive advantage, especially in fields where R&D efforts are determining to develop superior products (Urban and Hauser, 1993) . This is where the efficiency of the information system becomes critical. Anticipation takes place in the very upstream stages of product development when market characteristics must be clearly defined. This supposes that the information system is fed with regular and updated data which enable to identify customer needs and which make market evolution more predictable (Urban and Hauser, 1993). At that stage, the role of the sales force is decisive (Rochford and Wotruba, 1993) and requires heavy attention in NPD process. Even though some companies may chose to have a reactive strategy, others do have to adopt a pro-active strategy. Table 2.1. synthesises the main characteristics of both reactive and pro-active strategies.

**Table 2.1 - New product strategies**

Reactive strategies	Pro-active strategies
Defensive Imitative Second but better Responsive	Research and development Marketing Entrepreneurial Acquisition Alliances

Source: Urban and Hauser (1993)

The different reactive strategies were detailed in section 2.2.4.2. As concerns pro-activity, Urban and Hauser (1993) identified five main types of strategies. First, pro-activity can be based on R&D, which, in that case will pull the innovation process. Second, customer needs can be identified at very upstream levels, sometimes even when there are still latent. This is only possible when firms benefit from strong customer-oriented philosophies. Third, pro-activity can be directly issued from the willingness of an entrepreneur who has identified a market opportunity and will develop the necessary organisation to answer unsatisfied needs. Finally, acquisitions and alliances will generate new combinations of competencies and thus new products or services to be launched on the market.

#### **2.2.4.4. Organising to be more reactive**

- **A new way of rationalising manufacturing organisations**

The question is: how to rationalise product development and production while maintaining a flexible and reactive structure? In fact, as stipulated by de Terssac and Dubois (1992) it first supposes to forget the old Taylorian approach of rationalisation, for which the only purpose was to reach increased productivity. Today's rationalisation of the organisations is founded on new modalities, and especially new ways of organising human resources for production. The notion of rationalisation cannot be limited to the only actors, within the organisation, who are in charge of ensuring labour regulation. The new rationalisation has to be based on a multidisciplinary approach integrating larger fields of competencies (de Terssac and Dubois, 1992; Takenchi and Nonaka, 1986). This will definitely impact on the way human resources are managed as well as on the role



they play in manufacturing organisations. In fact, groups or individuals must have the ability to influence the organisation of labour as well as to gain independence from hierarchy.

According to Durand (1994), modern rationalisation of labour is directly linked with a new manufacturing model in large organisations. In fact, according to this author, today's large companies are all looking for solutions to decrease manufacturing costs with better quality and diversified products while reducing the launching and / or delivery delays of their new products or services. But there is not only one way of rationalising manufacturing organisations. The new rationalisation process requires flexibility and, consequently, permanent adaptations that will vary according to the micro and macro environments of each organisation, i.e. managing informal and unpredictable factors (Porter and Van Der Linde, 1995; Rochford and Wotruba, 1993). Moreover, rationalisation does not only apply to labour but to the whole manufacturing organisation. In fact, the new aspect in the notion of rationalisation is that when problems appear that cannot be solved thanks to formalised procedures, rationalisation, will provide help for easier decision-making. This can be done, for instance, by developing tools for favouring communication between heads of departments. Again, the human factors play a decisive role. In fact, the new notion of rationalisation does not separate the aspects that can be predicted and formalised from the ones that cannot, but tends to help managing together these two sides of a same problem (de Terssac and Dubois, 1992).

- **A need for organisational changes**

In a context of necessary speed and flexibility, the old sequential approach is not adapted anymore (Takenchi and Nonaka, 1986). The organisational structures of the companies must be adapted to this new context. Fujimoto (1989) clearly emphasised organisation as a key factor to higher effectiveness and Dumaine (1989) illustrated this point by mentioning that "everyone agrees that the worst way to speed up a company is by trying to make it do things just as it does, only faster" - i.e. efficient management of the NPD process, and the reduction of development delays imply organisational changes that must be carefully managed in order to avoid speeding up the wrong process -. Speeding up the process, but not at the expense of quality, was also stressed by R.G. Cooper<sup>1</sup> (1994) as a major challenge of modern NPD.

---

<sup>1</sup> To avoid confusion, note that 'Cooper' relates to Rachel Cooper and 'R.G. Cooper' to Robert G. Cooper.

The need for reactivity has impacted on organisations, including management of NPD. The issues raised by NPD are developed in the next sections.

#### **2.2.5. New product development**

Hart (1993) stated that “new product development is the process by which companies survive in the long term”. Even though this statement emphasises the importance of NPD, it does not provide clues about how to manage such a process. Moreover, the notion of ‘new product’ covers a wide range of innovations and requires to be defined more precisely. In fact, most researchers identify two main types of innovations: the incremental ones – i.e. improvement of existing products – and the radical inventions – i.e. products which constitute a breakthrough for the marketplace – (Trueman, 1998). According to Trueman, a majority of successful new products fall into the ‘incremental’ category of innovation since it is less risky. A more precise definition of the notion of innovation is given in section 2.3. dedicated to the specific issues raised by high technology sectors.

The challenges induced by new product development have been outlined by many researchers and among the main issues that have been covered in this field, many attempts were made to define the reasons for success or failure (Bowen et al., 1994; Hart, 1993; Johne and Nelson, 1990; Maidique and Zirger, 1984; Cooper, 1979). This opens different debates. First, as regards the measure of success, financial and non-financial criteria have been opposed to evaluate product performance. In addition, some researchers have claimed for the combination of different elements to explain how new product must best be launched (Hart, 1993; Johne and Snelson, 1990). Finally, the checklist approach – i.e. formal recipes to develop new products – has also been criticised for not providing information on how to concretely implement an efficient NPD process. This has paved the way for new research taking into account the type of industry studied, size of the organisation, management style, etc. and focusing on organisational matters (Millier, 1997).



### 2.2.5.1. Measuring success and failure in new product development

As stressed by Urban and Hauser (1993), success is dependent upon different variables. However, apart from the definition of key factors of success, questions such as 'how to assess the performance of a new product?' and 'what is the meaning of success?', are central for all the researchers concerned with NPD. Hart (1993) identified two main types of performance measures: financial and non-financial ones that are presented in table 2.2.

**Table 2.2. - Financial and non-financial measures**

<b>Financial measures</b>	<b>Non-financial measures</b>
<ul style="list-style-type: none"><li>- profit-based</li><li>- asset-based</li><li>- sales-based</li><li>- capital-based</li><li>- equity-based</li></ul>	<ul style="list-style-type: none"><li>- design-based</li><li>- activity-based</li><li>- market-based</li><li>- technologically-based</li><li>- commercially-based</li></ul>

Source: Hart, S. (1993)

Even though business viability is often evaluated on the basis of financial criteria, different researchers have claimed that performance measure should not be confined to financial issues (Hart, 1993; Faust, 1993; Hayes and Abernathy, 1980). According to them, financial criteria generally deal with short-term effects and may be influenced by other factors such as mergers, investments, price cutting, weak R&D investments, etc. Thus, the risk in that case is to have a static and punctual representation of the situation that does not guarantee future performance.

These criticisms have lead researchers to consider non-financial measures in the evaluation of NPD performance (Hart, 1993). However, this supposes a less quantifiable approach, directly emerging from the definition of success that managers consider to be relevant. In this context, the research done by Hart concerning the dimensions of success as defined by business people supports the fact that uni-dimensional, financial factors are not seen as a priority. The dimensions of success which were mentioned by managers focus on competitive aspects, including technology, cost and time-to-market. In fact, the nature of NPD achievement must not be evaluated on isolated criteria but rather on a multi-dimensional basis. Moreover, it appears that the issue is to understand the type of objectives initially established in order to assess final success. "The nature

of the objectives set should determine the way in which performance of the project or programme is measured" (Hart, 1993). Taking the example of a design-focused strategy, Faust (1993) supported Hart by mentioning that design, as a creative discipline, is hardly measurable with quantitative tools.

#### **2.2.5.2. Success and failure in NPD**

Many researchers have worked on what makes a new product more successful than another and have attempted to provide formal checklists of key factors of success. As shown in the next paragraphs, research relating to success and failure in NPD has clearly evolved in the last two decades. In the list of successful factors provided by Cooper (1979), NPD success is directly related to marketing concerns – e.g. product advantage, competitive marketing mix, etc. -. As for Booz et al. (1982) and Maidique and Zirger (1984), they globally agreed with most of the factors given by Cooper but also introduced a couple of variables dealing with the wider notion of project management – e.g. management support throughout NPD, importance of the R&D stage and technological superiority as well as formalisation of the NPD process -. Finally, Bowen et al. (1994) are totally project management oriented in their recommendations relating to successful NPD. This vision was supported by R.G. Cooper (1994) for whom focusing on process enables to know "what really happens during the course of the project".

##### **• Cooper (1979)**

On the basis of discriminant analysis relating to 195 projects, Cooper (1979) has established a list of factors that differentiate between new product success and failures. These factors can be classified as follows:

##### **- Organisational level:**

- the new product must fit corporate resources and know-how at the managerial, marketing, technical and production levels.

##### **- NPD process:**

- the original idea must be market-derived and the firm must have market knowledge;
- NPD must be supported by heavy investments;
- there must be a strong marketing communications and launch effort.



- Product:
  - must have a good price/advantage ratio.
- Market:
  - the environment must not be too dynamic and competitive;
  - the market must not be too narrow.

The majority of the factors tested by Cooper (1979) are based on a correlation between the nature of the market and the internal resources of the firm. Even though, in a context of increased competition, most of the above-listed criteria may appear to be issued from common sense, they emphasise the importance for the firm to carefully evaluate its environment in the upstream stages of NPD and, thus, it values efficient information systems. Moreover, it also stresses the determining role of marketing and the necessity to adopt a strong market-orientation to meet customers' requirements. The previously-listed factors are also mentioned by Urban and Hauser (1993) as being major elements influencing product success. However, the list provided by Cooper (1979) does not supply any information about the way NPD must be managed on a daily basis and may not be adapted to specific sectors such as high tech industries which, for instance, rarely have the ability to enter "large, high need, growth market".

- **Maidique and Zirger (1984)**

Maidique and Zirger (1984) on the basis of two complementary surveys administered to participants of the Stanford-AEA Executive Institute identified 8 clusters to explain the circumstances under which product success is likely to be greater. These factors can be classified as follows:

- Organisational level:
  - the organisation must be proficient in marketing and support product launch with heavy investments in communication and sales;
  - the new product must fit existing corporate strengths.
- Managerial level:
  - there must be a strong managerial support throughout the whole NPD process.
- NPD process:
  - the new product must be issued from in-depth understanding of the customers;

- the R&D stage must be well-planned and efficient;
  - the R&D, marketing and production functions must be co-ordinated;
  - the product must be introduced early into the market.
- Product:
- must provide a high contribution margin to the firm.

The surveys conducted by Cooper (1979), Booz et al. (1982) and Maidique and Zirger (1984) have lead to common conclusions relating to:

- the necessary understanding of customers;
- market knowledge, marketing proficiency and adequate resources dedicated to sales and promotion;
- correlation that must exist between the firm's know-how and the new product to be developed;
- synergy and proficiency as regards R&D, marketing and production.

Even though Maidique and Zirger (1984) also stressed the R&D stage and the level of management support as being crucial to favour new product success, the factors emphasised by the two above mentioned surveys are mostly product and marketing oriented.

Agreeing with Cooper (1979) and Maidique and Zirger (1984), Booz et al. (1982) also established that product fit with market requirements, a favourable competitive environment and compatibility between the new product and corporate strengths are major factors influencing new product success. Moreover, Booz et al. (1982) also emphasised the notion of top management support and formalisation of the NPD process as key factors impacting product success. Such factors also appeared in the study conducted by Bowen et al. (1994) which is much more project management oriented than the surveys implemented by Cooper (1979) and Maidique and Zirger (1984).

**• Bowen et al. (1994)**

Bowen et al. (1994) identified the following elements as being decisive in successful projects:

- Managerial level:
  - NPD must be directed by a clear guiding vision;
  - human resources must be managed so as to match the right leader with the right project.
- NPD process:



- the experience gained in parallel with the number of projects will be a competitive advantage;
- processes must always be improved;
- prototypes will enable to link the different project members;
- project team members must equally participate in decision-making;
- design for assembly (DFA), design for manufacturability (DFM) and commonality will support efficient NPD (see section 2.5.11.).

In fact, in the preceding list, the angle taken to analyse successful factors is not the mere product and marketing strategy anymore but the project itself and the way it is managed. In this sense, the vision provided by Bowen et al. is much wider than the ones provided by Cooper (1979) and Maidique and Zirger (1984) and leads to more implications in terms of organisational and managerial aspects. It directly relates to the notion of project management and involves the different corporate functions, rather than mainly focusing on marketing factors.

Complementary to the previous lists of factors, the “fifteen key lessons for new product success” provided by R.G. Cooper (1994) provide a wide overview of the elements that positively influence new product efficiency. These key factors are listed in table 2.3.

**Table 2.3. - Fifteen key lessons for new product success**

- 1- The number one success factor is a unique superior product: a differentiated product that delivers unique and superior value to the customer.
- 2- Strong market orientation – a market-driven and customer-focused new product process – is critical to success.
- 3- Look to the world product: an international orientation in product design, development, and target marketing provides the edge in product innovation.
- 4- More predevelopment work – the homework – must be done before product development gets under way.
- 5- Sharp and early product definition is one of the key differences between winning and losing at new products.
- 6- A well-conceived, properly executed launch is central to new product success. And a solid marketing plan is at the heart of the launch.
- 7- The right organisational structure, design, and climate are key factors in success.
- 8- Top management support does not guarantee success, but it sure helps. But many senior managers get it wrong.
- 9- Synergy is vital to success – “step out” projects tend to fail -.
- 10- Products aimed at attractive markets do better; market attractiveness is a key project-selection criterion.
- 11- New product success is predictable; and the profile of a winner can be used to make sharper project-selection decisions to yield better focus.
- 12- New product success is controllable: more emphasis is needed on completeness, consistency, and quality of execution.
- 13- The resources must be in place.
- 14- Speed is everything! But not at the expense of quality execution.
- 15- Companies that follow a multistage, disciplined new product game plan fare much better.

Source: R.G. Cooper (1994)

The factors of success for new products or projects that have been determined by researchers can be synthesised as follows:

- customer focus;
- organisational and managerial aspects, including management of NPD process – e.g. early development activities, multidisciplinary teams, synergy between functions, formalisation and planning of development activities, management of resources – and involvement of top management -;
- market(ing) orientation and proficiency;
- market attractiveness;
- intrinsic characteristics of the product leading to superiority – e.g. competitive marketing mix -.

Each of the factors in the preceding list influences the others. Top management is responsible for setting a customer-focused guiding vision. At this stage, understanding user needs is crucial for successful product innovation (Bolton and Williams, 1995) and requires efficient market research, including data collection but, above all, efficient communication of this information throughout the organisation – i.e. a well-organised information system -. In fact, effective use of market information was emphasised by Hart et al. (1999) as being the central element of new product success.

In addition to the previously mentioned responsibilities, top management also has to support the NPD process with adequate resources. The organisation has to be structured in accordance with the managerial aspects so as to favour efficient NPD – e.g. increasing synergies between functions -. R&D, production and marketing proficiency also depends upon the resources allocated by top management. Finally, product characteristics and competitiveness are directly dependent upon the previous factors. These factors are synthesised in fig. 2.2.



**Fig. 2.2. - Hierarchy of factors influencing product success**

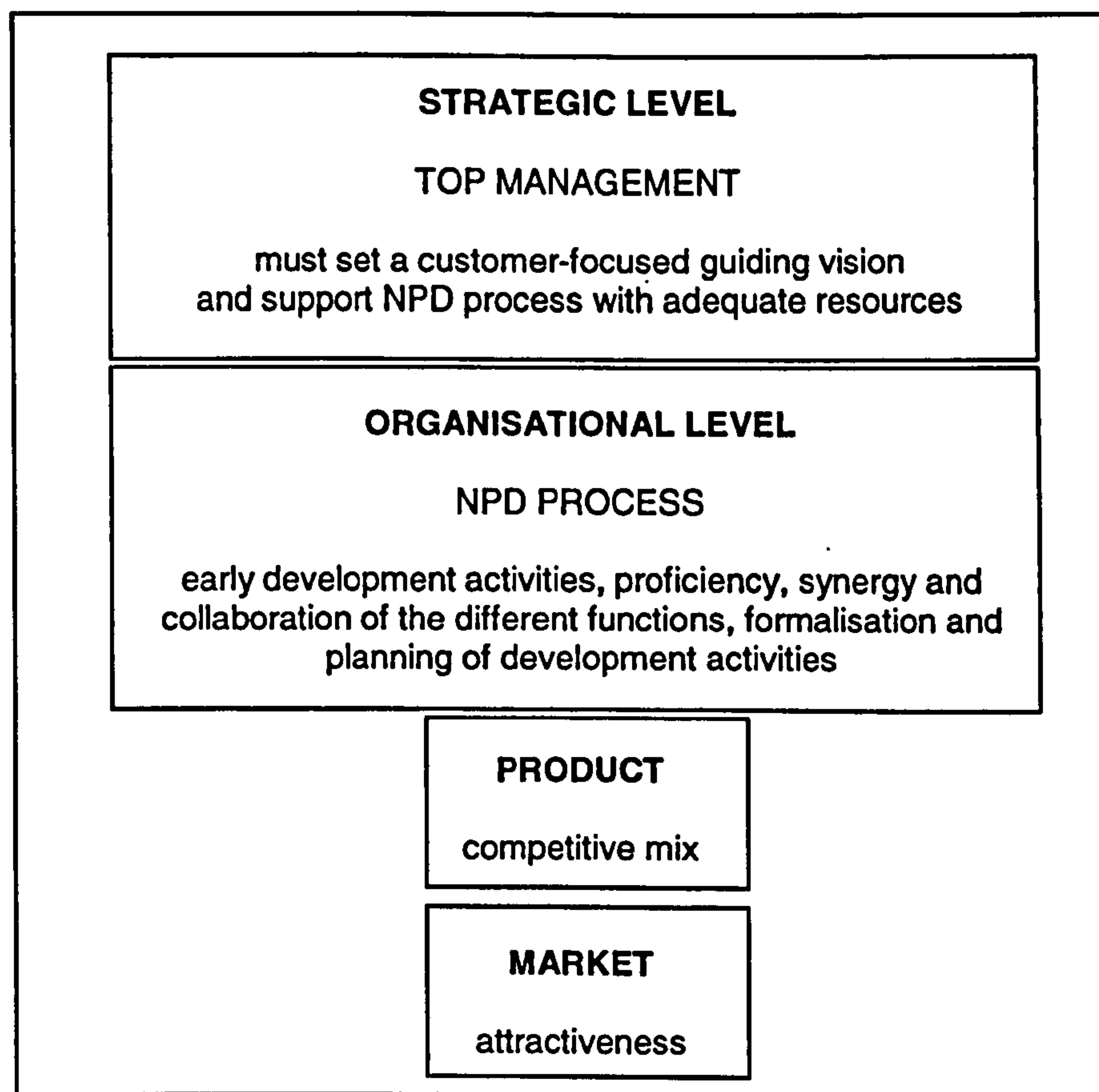

### **2.2.6. NPD and time-to-market**

According to researchers (Jones and Fearis, 1995; Durand, 1994), in order to obtain lower manufacturing costs, with increased quality and diversified products while reducing the launching and delivery delays, companies must implement different changes:

- integrating R&D and industrialisation so as to transform as quickly as possible an innovation into a functionality that fits customers' requirements;
- developing organisational productivity and working with just-in-time production between partners so as to increase the level of quality and to limit stocks;
- integrating the different functions within the company to increase productivity - i.e. through project management and multidisciplinary teams -, which means that the employees become less specialised but more polyvalent;
- developing a new form of employees' mobilisation and team culture.

The notion of process management is essential (Adler et al., 1996; Jones and Fearis, 1995, Durand, 1994). Managers must integrate the fact that product development is not a sequential list

of projects but an intricate process with a limited capacity and workload. In fact, there exist similar tasks across projects that would enable skills and equipment sharing throughout the whole process of product development but careful project management is required to avoid bottlenecks. For example, creating cross-functional teams may mean that key people have to deal with several projects at the same time which would finally lead to increasing delays. To avoid such problems, some companies, especially in the field of software development, use independent teams that are responsible for one project at a time. However, this approach is costly and may still lead to congestion due to an underestimated amount of rework at the end of the process.

The solution presented by Adler et al. (1996) in order to increase product development management efficiency consists in a precise identification and planning of the organisation's resources. The "Processing Network Model" (see fig. 2.3.) clearly identifies the numerous iterations that take place during a project and helps to plan the utilisation of human and material resources within the organisation.

**Fig. 2.3. - The Processing Network Model**

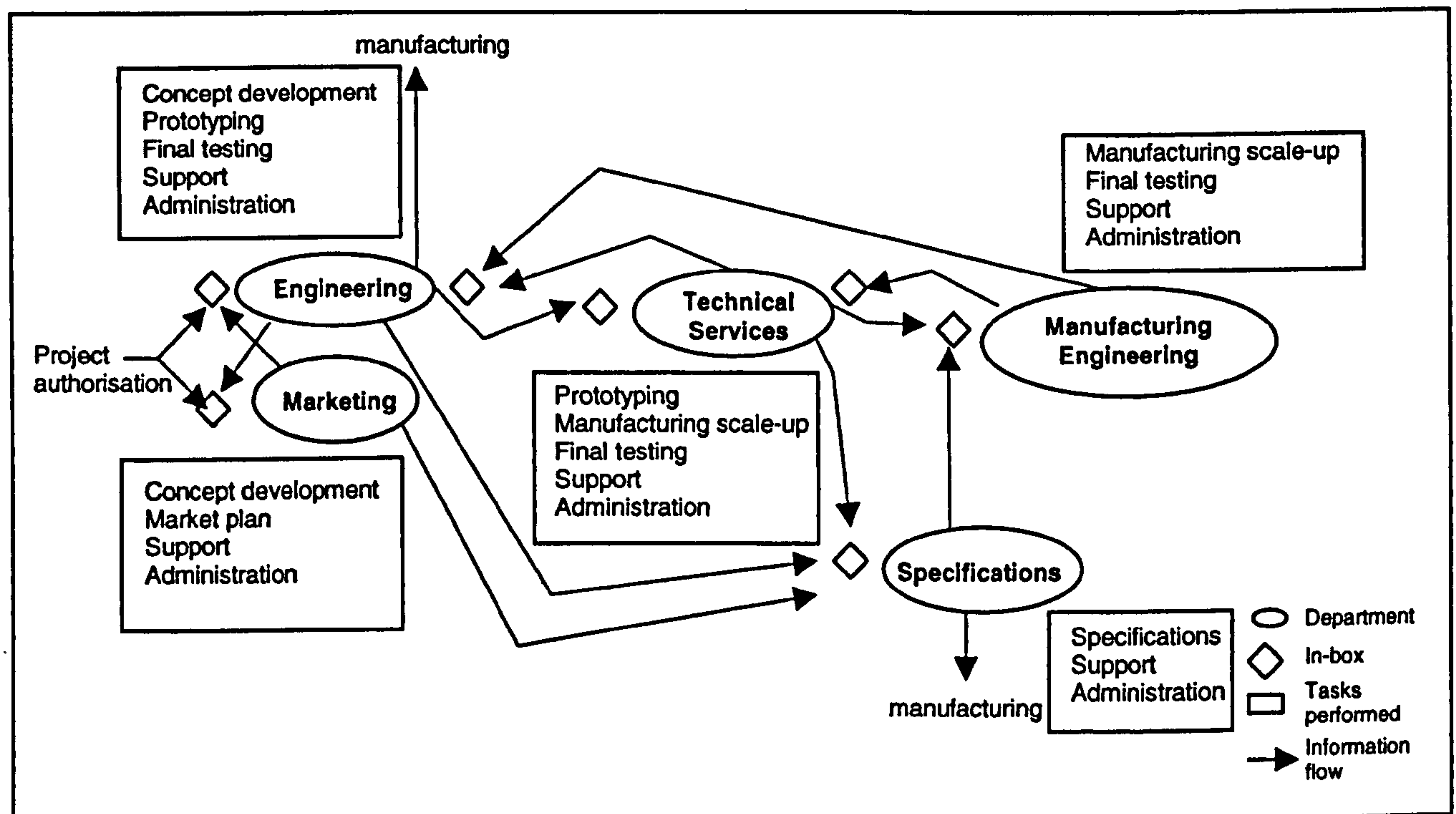

Source: Adler et al. (1996)

What must be outlined is that the "Processing Network Model" takes for granted that iterations occur during the NPD process. The objective, here, is not to avoid such iterations but to be able to manage them so as to make the best use of available resources. As stated by Jones and Fearis



(1995), efficient management of internal resources will enable to manage more projects at the same time and, thus, to launch more products.

In addition to the above mentioned organisational aspects, technology will also help reducing the time to market for a new product. Techniques such as 3D modelling and rapid prototyping also provide opportunities to reduce the development time, and costs, that occur before launch (Jones and Fearis, 1995). This will be developed in section 2.4. relating to design management.

#### **2.2.6.1. The benefits of reducing product development delays**

As stressed in the preceding sections, today's environment requires business to be reactive. In such a context, manufacturing companies still have to respond to the challenge of maintaining high levels of sales but they also have to reduce the pre-launch development time (Jones and Fearis, 1995). As stated by R.G. Cooper (1994), "speed is the new competitive weapon". Basically, quicker development means savings in time and, consequently, in costs and money (Dumaine, 1989; Jones and Fearis, 1995). Even though this statement is willingly simple, it summarises the main benefits of shorter product development cycles.

More precisely, from a commercial point of view, shorter product development delays will enable the organisation to gain market shares and to make profits among the customers waiting for an innovation to be launched. Some customers - the so-called 'early adopters' - are ready to pay more for innovative products. This can be explained by economic reasons, such as the impact of updated equipment on the quality of products to be manufactured, but it can also be explained by subjective reasons, such as the psychological value of owning high tech equipment. It will also enable the organisation to choose the best distribution networks when customers cannot be reached directly. This is a determining advantage when considering the increasing difficulty to access distribution channel, as mentioned at the beginning of this chapter.

According to Stalk et al. (1992), quicker product development enables organisations to launch more recent and technologically-advanced products on the market. Advantages issued from quick responsiveness amplify all the other competitive advantages. Moreover, reduction of delays directly impacts on the level of risks to be taken since demand estimates can be more precise when done

on the short term. This can provide a decisive competitive advantage when considering today's complex nature of demand.

As shown in fig. 2.4., reducing NPD delays will lead to an extension of the product's life on the market as early introduction seldom means that the product will become obsolete earlier than its competitors (Smith and Reinertsen, 1991).

**Fig. 2.4. - Early introduction can increase sales life and market share**

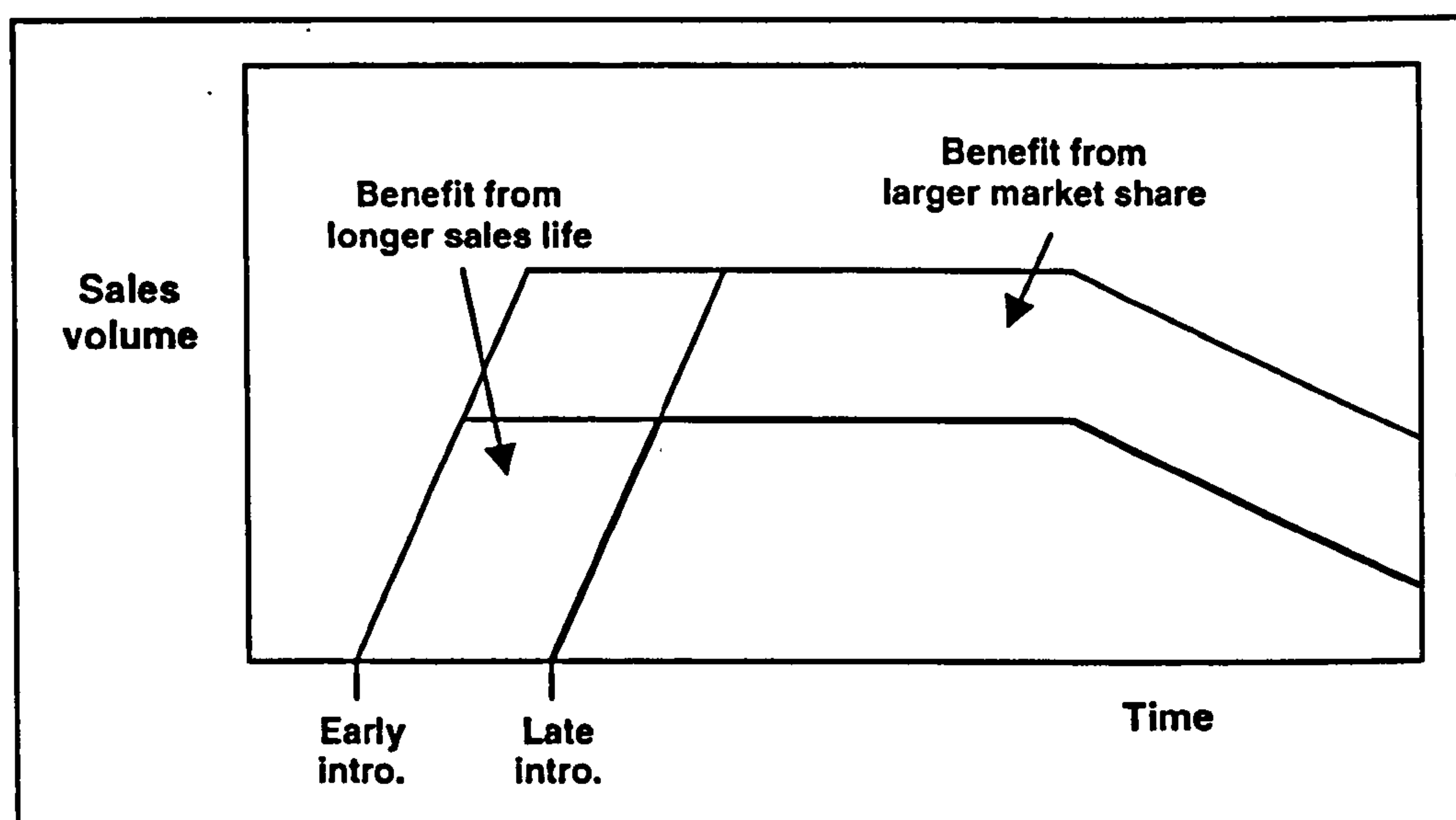

Source: Smith and Reinersten (1991)

In the specific case of high tech industries, however, competitors can rapidly improve their products on the basis of the innovation launched first on the market (patent), which makes the initial product become obsolete more rapidly. However, the difference in price that will result from the fact that the initial product benefits from the learning curve and that the new technology incorporated in the 'me-too' products is more expensive, eventually generates two offers that do not compete on the same targets.

Shortening NPD delays will also lead to an increase in market share as the first product on the market will benefit from a monopolistic situation. As mentioned by Smith and Reinertsen (1991), in certain cases, customers may be dependent on the first brand they purchased for compatibility reasons – i.e. in the field of computing, the standard of initial equipment will influence the purchasing of further accessories -. Being first on the market will also enable the organisation to make higher profit margins since the monopolistic situation leads to more pricing freedom when the



product is launched (Jones and Fearis, 1995; Dumaine, 1989). As shown in fig. 2.5., this situation will also enable the organisation to benefit from the manufacturing learning curve and lead to economies of scale, and, eventually, to high profit margins, once competitors appear on the market place (Smith and Reinertsen, 1991).

**Fig. 2.5. - Early entrants can benefit from the manufacturing learning curve**

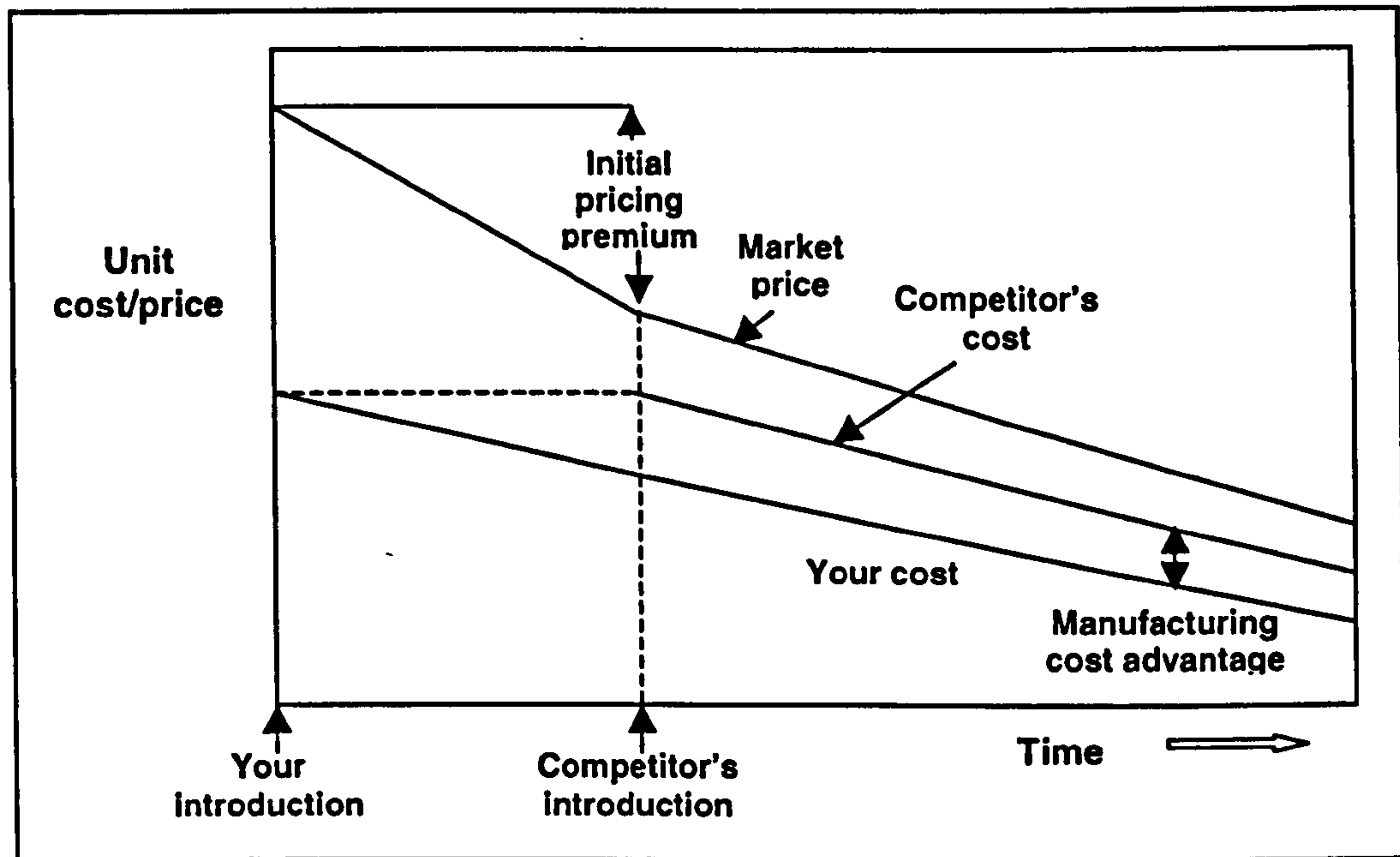

Source: Smith and Reinersten (1991)

Shortening development delays will also enable manufacturers to dedicate their resources to other projects. This will lead to an increased number of projects being developed which will enable to spread risk over different products and markets and which will also potentially generate more profits (Jones and Fearis, 1995). Moreover, as explained by Smith and Reinertsen (1991), quick product development gives a company the opportunity to choose to launch its product later on the market but to incorporate the newest technology, or to use components which price have decreased. In that case, the company willingly decides to launch its product later but with a competitive advantage in terms of technological advance or price. Being reactive will also improve corporate image since the company is viewed as innovative and dynamic by final users, purchasers, distributors, etc. This also impacts the organisation internally. In fact, reducing NPD delays will often lead to better communication within the organisation due to multidisciplinary teams and higher motivation for employees when time reduction objectives are met (Dumaine, 1989).

Finally, as stated by Smith and Reinersten (1991), long development cycles must be avoided since they inevitably lead to even longer cycles and tend to threaten the firm's competitiveness on the long term. This process is illustrated in the fig. 2.6.

**Fig. 2.6. - Long development cycles generate even longer cycles**

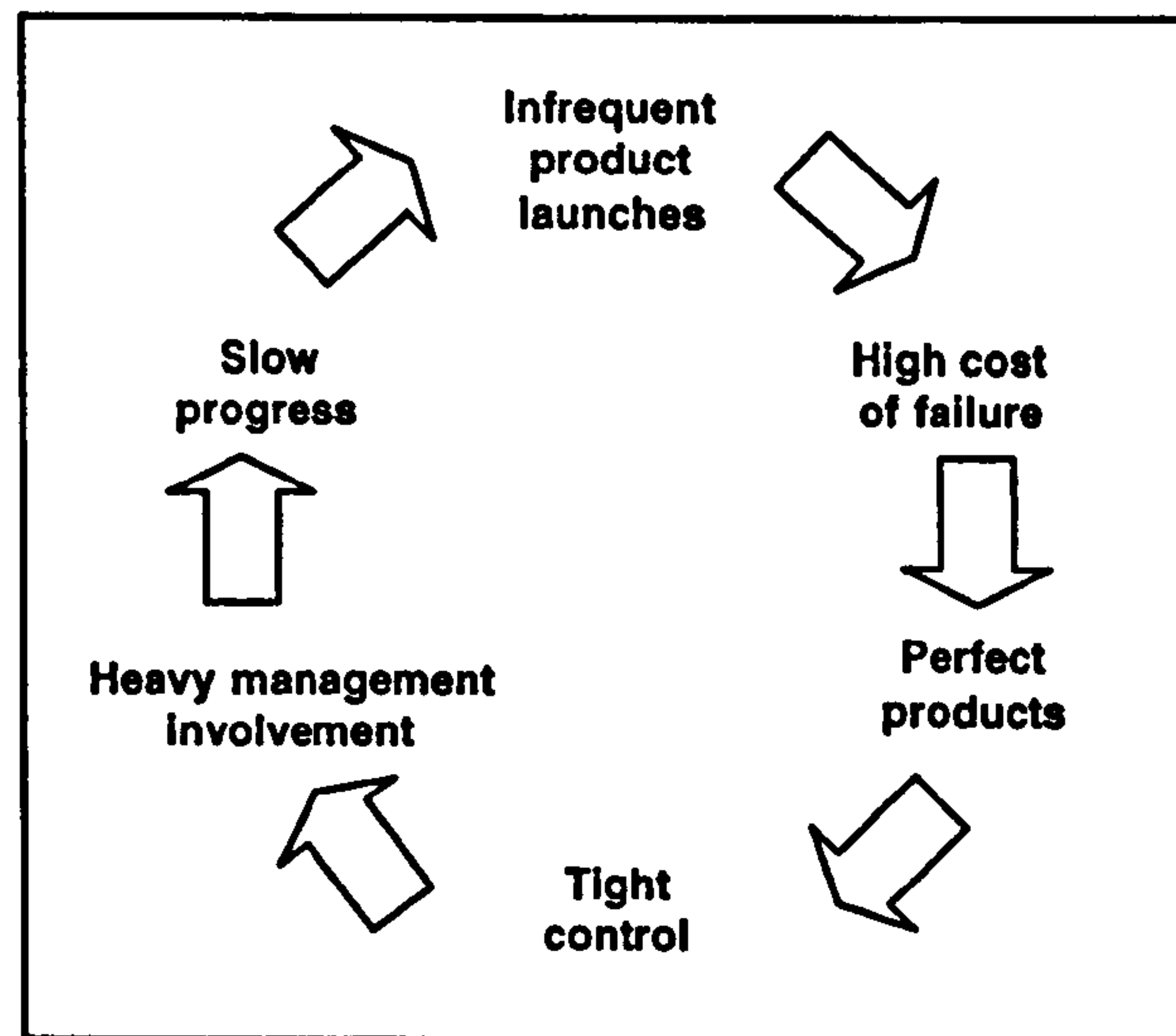

Source: Smith and Reinersten (1991)

In fig. 2.6., the NPD process is made heavy by tight control. Thus, the firm can only launch a restricted number of products on which the risk is concentrated. Eventually, the firm is under pressure to market very good products, which leads to tighter control and longer development delays.

As shown in the previous section and as emphasised by Smith and Reinersten (1991), reducing delays has essential strategic implications. However, some researchers have also argued that reducing delays may have negative consequences.

### **2.2.6.2. The limits of reducing product development delays**

As stated by R.G. Cooper (1994) and Dumaine (1989), shorter development cycles must not be detrimental to quality. This is the main argument that plays against quick product development. However, Durand (1994) also stressed three main limits to increased rationalisation of the NPD process. First, he argues that working in just-in-time and being pushed by constraints of profitability will increase the turnover generated but not the number of people employed and will not impact on



unemployment rates. Second, NPD methods will have to be adapted to social environments. For instance, in Japan, 'Toyotism' was associated with a life commitment of the employee within his/her company, which was not automatically the case in countries to which the concept was exported, thus leading to cultural maladjustment. Finally, even if some companies vaunt the high level of autonomy employees have within their structure, this freedom is most of the time reduced and focused towards reaching the pre-determined objectives.

Consequently, Durand's (1994) opinion is that Ford's methods are still applied but that today's organisation of labour is founded more on employees' motivation to reach pre-determined objectives, i.e. 'flexible Taylorism'. The human factor is, thus, central in today's NPD processes.

### **2.2.7. Multidisciplinary teams**

The need for synergy, co-ordination and inter-disciplinary projects was mentioned in the preceding sections relating to NPD (Jones and Fearis, 1995; Bowen et al., 1994; Durand, 1994; Maidique and Zirger, 1984; Cooper, 1979). In fact, in the context of reactivity which was described in section 2.2. concurrent product development (CPD) through the implementation of multidisciplinary teams and cross-functional collaborations has been stressed as being vital for organisations that are under pressure to shorten their NPD delays. However, concurrency may increase the time spent in the initial stages of the NPD process since it will require further upstream analysis and exchanges so as to develop the adequate solution. But, eventually, this will be compensated by less iterations farther down the development cycle (Giard and Lee, 1994).

CPD will produce different benefits including a reduction of development and manufacturing costs as well as of NPD lead time since redundant activities will be eliminated. Moreover, it will enable customer integration and validation in the earlier stages of NPD (Faust, 1993; Cooper, 1990). However, as stressed by Jones and Fearis (1995), even though the principle of CPD is simple in theory, it is not so easy in practice. First, concurrent engineering requires organisational changes and more precisely the implementation and adoption of a team culture. Then, the NPD process in itself will suppose efficient communication and planning. Communication is the way by which team members will be able to interact and to eventually achieve common goals. In the sequential approach, communication is linear, going from R&D to design, production engineering,

manufacturing, marketing and sales. However, in the multi-functional team approach, communication takes place within a more flexible frame with many different information flows that evolve in parallel (Jones et al., 1995). In fact, a study conducted by Jones et al. with three British companies, stressed that the functions participating in the NPD process still feel that they do not receive or give effective communication from/to all the other functions. As mentioned by the authors "the key operational problems to be addressed are how to increase the overall effectiveness of communication between functions in multidisciplinary teams involved with NPD to a level where all receive effective communication from each other, how to improve communications between R&D / design / production engineering / manufacturing and marketing / sales, and how to ensure that all functions are kept equally well informed throughout development projects". Senior management has a central role to play in favouring the implementation of well-balanced cross-functional communication system.

In parallel with communication aspects, planning will also be decisive. In fact, multidisciplinary teams and CPD will generate many overlaps which will require careful scheduling so as to avoid bottlenecks and, eventually, delays (Jones and Fearis, 1995; Adler et al., 1992).

#### **2.2.8. Organising for a shorter product development process, a central role for managers**

According to Wheelwright and Clark (1995), senior managers must understand the importance of product development to the success of the business. The problem is that even if product development is recognised as an important factor, most managers do not concretely implement the necessary actions to make it central to their organisations. Most of the time, their involvement is limited to allocating financial and human resources and to intervening in key steps of the decision-making process. As product development covers almost all the activities in the company, managers must be aware that they have a central role of co-ordinator to play.

When little co-ordination exists between the company's strategy and development projects, most problems turn out to be solved throughout the different steps of the product development process. Consequently, managers have to intervene regularly in order to make key decisions, which leads to a centralisation of the authority and slows down the whole process (Wheelwright and Clark, 1995; Smith and Reinersten, 1991). Emergency, that should be avoided, appears at that stage.



Moreover, the above-described consequences of a wrong organisation also impacts on employees' motivation as they realise that they are not included in decision-making. Eventually, further delay is generated by the necessity of regular validations of the process by senior managers.

Another point that justifies a heavy managerial involvement in the product development process is that whereas some factors can be controlled, others such as technological or competitive elements or even the nature of demand cannot be mastered. Consequently, product development requires a comprehensive view of the organisation, which can only be provided by senior managers. Ettighoffer and Blanc (1998) and Stalk et al. (1992) insist on the necessity of a managerial 'vision' of the organisation so that time management becomes a central strategic priority. Reducing delays requires a clear message, to re-organise the whole structure and to fight against resistance to change.

The role of managers is of tremendous importance in guiding the organisation towards a strategic approach of NPD management. According to Wheelwright and Clark (1995) "companies that are good at product development have senior managers who explicitly connect development to the business strategy". The role of senior management is also stressed by Faust (1993) for whom clearly defining common goals is the first requirement of any efficient concurrent product development process. Moreover, senior managers will also be the ones who will be able to implement the appropriate organisational structures and cultures to favour, for instance, the adoption of concurrent engineering and multidisciplinary teams (Jones and Fearis, 1995).

### **2.3. Synthesis of key elements and conclusions**

The preceding sections have outlined the need for reactivity and stressed how it has impacted on NPD processes. The following key factors have emerged:

#### **Reactivity**

- Today's environment requires to be reactive, and, even, pro-active.
- Information technologies have emphasised the need for reactivity.
- There is a need for organisational changes :
  - rapid decision-making;
  - the old sequential approach is not adapted anymore and must be replaced by concurrent

development and multidisciplinary teams;

- NPD delays must be shortened so as to gain a competitive advantage and without being detrimental to quality.
- Managers have a central role to play in adapting the organisation and setting a guiding vision.

## **NPD**

- Product success will mostly be influenced by:
  - organisational factors;
  - managerial factors including management support;
  - market-driven/customer-focused orientation;
  - cross-functional co-ordination;
  - marketing, technical and production proficiency and resources;
  - pre-development activities;
  - prototypes;
  - DFA/DFM/commonality;
  - early introduction;
  - right mix;
  - launching and marketing plans.

These key factors are synthesised in fig. 2.7.

This part has stressed the necessity to revise the Taylorian approach so as to turn the sequential NPD process into a concurrent and inter-disciplinary one. As stated by Faust (1993), the concept of cross-functional team is not new. Nevertheless, "examples of 'barrier-free' teamwork are still the exception rather than the rule". In fact, as it will be demonstrated in the next sections, developing interdisciplinary interfaces raises many issues in the field of high technology.



Fig. 2.7. - Efficient NPD in a context of reactivity

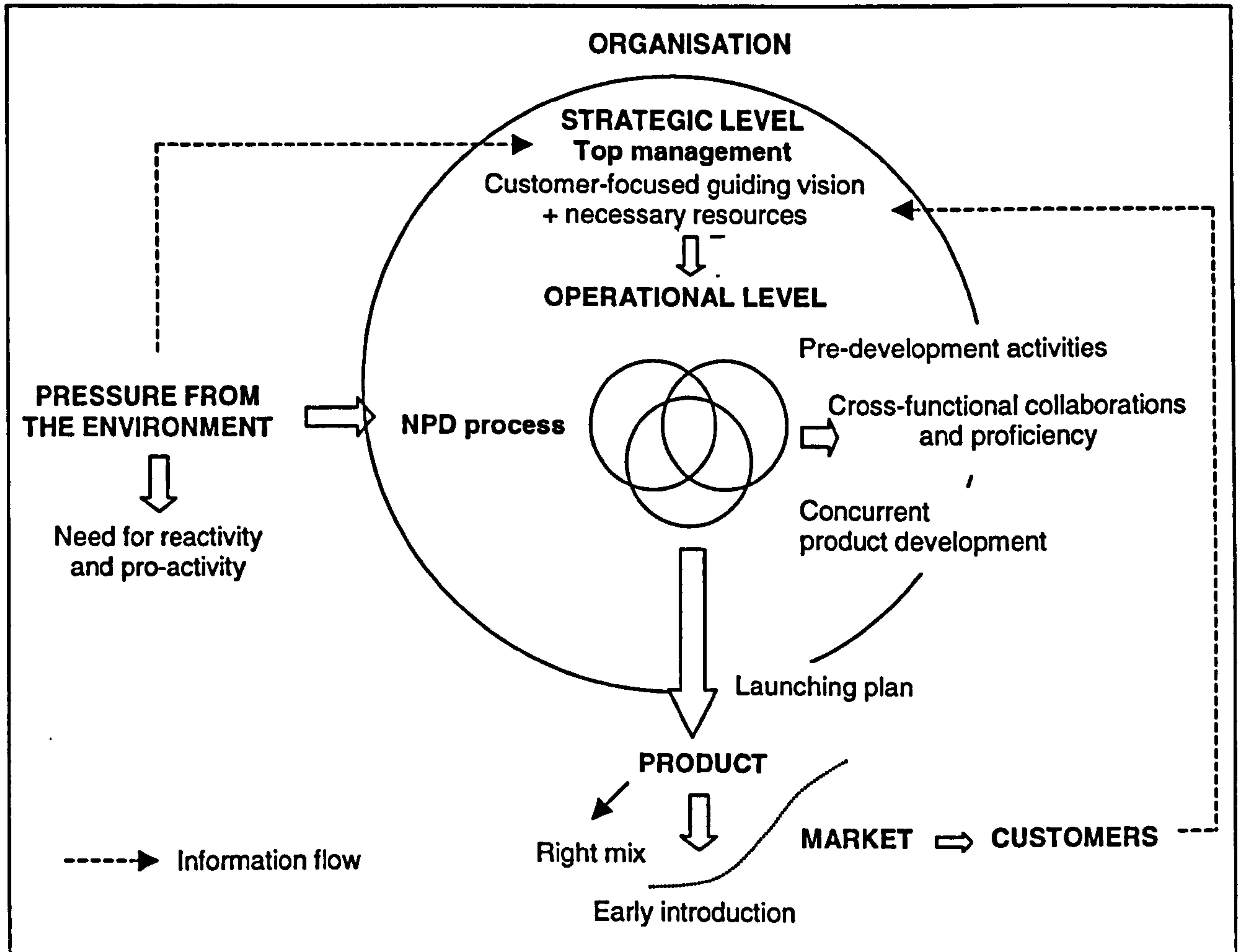

## 2.4. The characteristics of the high tech environment and the necessity to develop cross-functional interfaces

### 2.4.1. Introduction

The preceding parts of the dissertation have examined the notion of reactivity and have stressed the necessity of adequate NPD processes. Whereas the issues previously raised apply to all the sectors, the next sections will focus on the specific challenges that the high tech sectors have to face, since such sectors are at the centre of the research problem. In order to clearly set the context of the topic, the notion of high technology will first be defined. Then, the characteristics of management and marketing in high tech organisations will be detailed. Finally, the dissertation will focus on the issues relating to R&D/marketing and production interactions which are at the centre of the NPD process.

## 2.4.2. Defining high technology

### 2.4.2.1. What is 'high tech'?

The expression 'high tech' is commonly used to define activities with heavy technological inputs. However, this requires to be better defined so as to know exactly about the strategic and managerial implications of such activities. First, confusion is frequent between the terms 'science', 'technology', 'invention', 'innovation', 'technological innovation' and 'new product'. These terms will be defined in the next sections.

### 2.4.2.2. What is 'science' ?

According to Monck et al. (1988), there are two major aspects to be outlined when defining science. First, "science aims at the discovery and understanding of natural phenomena" and, second, "it proceeds by means of a methodology based on observation, experimentation and reason". But, as shown in fig. 2.8., the term 'science', in itself, implies different types of activities going from 'pure'/basic science to 'applied'/mission-oriented science, and which constitute the very first steps of the R&D projects continuum (Millier, 1989). Even if it may be quite difficult to set a clear limit between the two, it can be mentioned that 'pure' science defines basic scientific understanding of natural phenomena whereas 'applied' science aims at providing a solution to an identified problem and leads to the development of concrete applications.

**Fig. 2.8. - The R&D projects continuum**

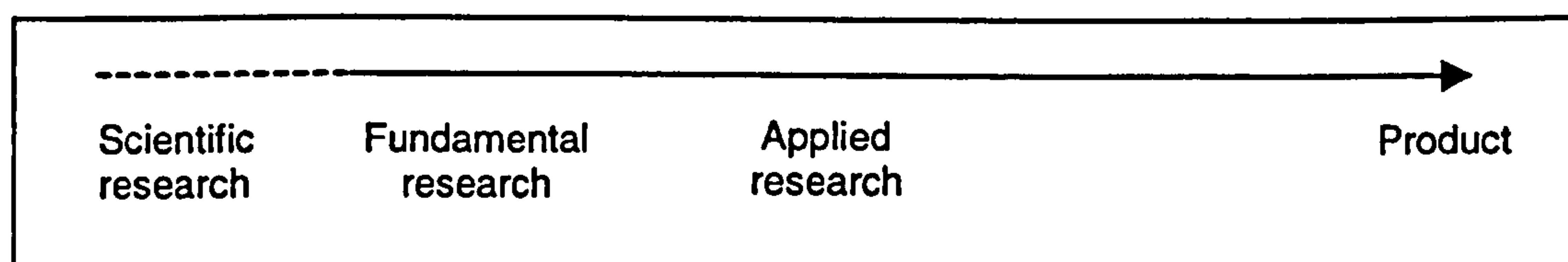

Source: adapted from Millier (1989)

### 2.4.2.3. Invention, innovation and new products

Freeman and Soete (1997) distinguish the term 'invention', which describes new ideas or functions, and the term 'innovation', which implies that the new product or process is launched on the market. This definition is supported by Millier (1989). Thus, different inventions may be developed



throughout the innovation process but “inventions do not necessarily lead to technological innovation”. Millier (1989; 1997) also considers innovation and new products as synonymous. According to him, they are both pulled by the market and guided by technological as well as commercial objectives. However, Millier outlines that these terms encompass different degrees of novelty, for example: repositioned products (product’s perception by customers is changed), reformulated products (physical characteristics are modified) – which both can be considered as incremental innovations - or original products which result from radical innovations. Such a distinction is fundamental since improved versions of existing products and products that constitute a radical breakthrough will not engender the same level of risk, and thus, will suppose different managerial and marketing approaches (Trueman, 1998).

Besides of the notion of ‘science’, the concepts of technology and technological innovation also require careful definition.

#### **2.4.2.4. Technology and technological innovation**

According to Roche and Grange (1999), there tends to be a confusion between technique and technology and these two terms are often substituted to one another. In fact, technology is a combination of different techniques. According to Galbraith (1967) “technology means the systematic application of scientific or other organised knowledge to practical tasks”. Monck et al. (1988) go further than Galbraith in their definition of technology. According to them, technology is not simply ‘applied science’. “Technology is both a knowledge concerned with the solution of practical problems - or ‘know how’ - and also the tools and artefacts which are used to achieve those solutions: it is both ‘software’ and ‘hardware’”. This definition is supported by Roche and Grange (1999), as well as by Price (1996) for whom ‘technology’ is synonymous with ‘know-how’ derived from science in order to develop a solution that will meet new needs. Thus, technology can be defined as both the application of science and techniques and the processes it encompasses to develop an answer that will help solving practical problems. In fact, such a definition supposes that the needs to be met are carefully considered in the upstream stages of the technological project. As it will be outlined later on in the dissertation, it is a decisive point when dealing with the launching of new technological products.

As for the term 'technological innovation', it is used to define both the launching of an innovation and the whole process going from invention to launch. It also encompasses discrete products, new processes and new systems. A major distinction between technological innovation and seldom innovation is made by Millier (1989), for whom a technological innovation is technology-pushed whereas, as previously mentioned, a new product or innovation is market-pulled. This also supports the difference which will exist between radical and incremental innovations. Radical innovations will most often be technological ones – i.e. pushed by R&D – whereas incremental innovations, the improvement of an already existing offer, will often be market-pulled.

After having defined the term 'technology' – i.e. the 'tech' in 'high tech' – it is necessary to define the term 'high'.

#### **2.4.2.5. High technology is linked to R&D investments**

The U.S. Bureau of Labor Statistics considers that the term 'high tech' can be applied to the industries employing twice the number of technical staff and that have twice the R&D investment compared to the U.S. average. This definition was, for instance, the one on which Traynor and Traynor (1989) based their study of marketing approaches used by U.S. high tech firms. However, according to the OECD's criteria, a firm is considered to be high tech when R&D investments represent at least 4% of the annual turnover (Bouvard, 1998; Viardot, 1992).

The French Ministry of Economics, Finance and Industry, on the basis of an OECD classification, grouped French industries according to four levels of technological intensity: low, average/low, average/high and high. The classification done by the OECD is based on the concept of technology intensity. It takes into account « both the level of technology specific to the sector (measured by the ratio R&D expenditure to value added) and the technology embodied in purchases of intermediate and capital goods » (Hatzicronoglou, 1997). The classification is presented in table 2.4.



**Table 2.4. - Manufacturing industries classified according to their global technology intensity<sup>2</sup>**

<b>High technology</b>  1. Aerospace 2. Computers and office equipment 3. Electronics and communication 4. Chemistry	<b>Average/high technology</b>  5. Scientific instruments 6. Automotive vehicles 7. Electrical appliances and machines 8. Chemical industries 9. Other transportation equipment 10. Non electrical machines
<b>Average/low technology</b>  11. Rubber and plastic 12. Shipbuilding 13. Other manufacturing industries 14. Non-ferrous metal 15. Mineral and non metallic products 16. Metallic work 17. Oil refining 18. Ferrous metal	<b>Low technology</b>  19. Paper, printing and editing 20. Textile, clothing and leather 21. Food, drinks and tobacco 22. Wood and furniture

Source : Hatzichronoglou, T. (1997)

In table 2.4., the top two boxes concern the sectors with the highest technological inputs. These sectors are characterised by heavy R&D and/or manufacturing processes as well as by long development cycles. On the opposite, the two boxes at the bottom concern the industries with lower R&D investments and simpler manufacturing processes:

#### 2.4.2.6. R&D in France

According to the Observatoire des Sciences et Techniques (OST), FFR 180 billions were invested in R&D in France in 1998. Half of this sum was used by public organisations and the other half by companies. In terms of R&D expenditures over GNP, France ranks second in Europe after Sweden with respective ratios of 2.4% and 3.3%. It is followed by Germany – 2.3% - and the UK – 2.2% -. Concerning R&D funding, half comes from private companies, 43% from the State and 8% from foreign organisations. 39% of research is allocated to military purposes. These figures provided by the OST outline wide disparities as regards R&D investments among the French companies. In fact, over 90,000 industrial and service companies employing more than ten people, only 4,650

<sup>2</sup> This classification was used as a basis for the quantitative stages presented in chapter 5.

have a formalised R&D structure – i.e. employing at least one researcher per year -. Among these 4,650 companies, 185 cover ¾ of the total R&D investments. The conclusion provided by the OST is that French industrial research is concentrated on a small number of companies.

However, as it will be stressed in the next section, R&D expenditures are not the only reliable factor to classify companies as regards their technological intensity.

#### **2.4.2.7. Qualitative factors for identifying high tech firms**

R&D expenditures certainly provide a good indicator to evaluate the level of technology incorporated in a given activity. However, since technological inputs will vary throughout companies' lives (Millier, 1989), defining what is a high tech firm can hardly be restricted to quantitative factors. Viardot (1992), clearly stated that the term 'high tech' has become really vague and encompasses a wide spectrum of activities. According to him, literature has contributed to generate confusion as regards the definition of high tech products. Two aspects must be taken into account: the field of activity to which the product belong but also its intrinsic characteristics. Thus, qualitative aspects also have to be taken into account. According to Viardot (1992) and Shanklin and Ryans (1984), despite of the quantitative aspects of R&D level of investments, high tech companies are also characterised by three main criteria:

- their activities are innovating and involves a strong technological basis, incorporating the most recent scientific discoveries;
- new technology evolves very rapidly and quickly obsoletes existing technology;
- when new technologies are launched, they create new markets and generate new demands.

As a major characteristic of high tech companies, Jassawala et al. (1998) also outline they are always under pressure to launch new products as quickly as possible in order to meet financial objectives and to remain competitive. However, as stressed by Jones and Fearis (1995), companies manufacturing high technology products often have to deal with a long development time and high development costs, a shallow introduction stage followed by a short maturity period and a fast decline. This reinforces the necessity of efficient product development processes.



#### **2.4.2.8. High levels of uncertainty**

According to Moriarty and Kosnik (1989), two dimensions are common to most definitions of what is high tech: high market uncertainty and high technological uncertainty. Market uncertainty is defined by Moriarty and Kosnik as “ambiguity about the type and extent of customer needs that can be satisfied by the technology”. According to them, 5 main reasons explain this high level of uncertainty:

- customers may not be aware of the needs the technology is likely to meet;
- customer needs evolve and change rapidly;
- it may take time before technical standards are adapted to the innovation;
- technology adoption and spreading on the market is hardly predictable;
- finally, the size of the potential market is not easily predictable.

The question of market uncertainty was also developed by Price (1996) for whom confusion between potential needs and current demand is too frequent in technological sectors. Marketing high tech products requires to consider the market under new angles since there is often a wide gap between what can be perceived as a latent need and the existing demand for a given technology. Launching a new technology often requires to gain deep knowledge of human behaviours, and especially to take into account the fact that innovative products will generate reluctances. As stated by Franzén et al. (1995), “the greater the break between the new and old products for the system, the more difficulties to change”. This emphasises the need for heavy market orientation, heavy marketing inputs and new forms of management so as to reorganise entire markets and, consequently, to adapt internal strategies and organisation.

In addition to market uncertainty, high tech companies must face rapid technological change leading to technological uncertainty. According to Moriarty and Kosnik (1989) “technological uncertainty is higher where technology is new or rapidly changing”. Technological uncertainty is explained by five main reasons (Jones and Fearis, 1995; MacInnis and Heslop, 1990; Millier, 1989):

- product's performance can hardly be predictable;
- it is difficult to set a delivery timetable and to stick to it;
- it is difficult to know about the level of quality that attached services provided by the vendor will meet;

- the technology may have side effects;
- the risk of obsolescence may occur at any time.

Porter (1999) also stressed the challenge that market and technological uncertainties raise for managers. According to him, the easy solution is often to minimise risks by adopting strategies of imitation. On the opposite, companies can decide to take different directions so as to explore all the potential opportunities.

The above-listed factors are complemented by Millier (1989) for whom the type and intensity of uncertainty is different when there is a technology-pushed or market-pulled project. Moreover, Millier adds a third uncertainty dimension to the definition of high tech, which is technical - i.e. the technical feasibility of the technological innovation -. This is particularly relevant when considering the definition of 'technological innovation' which includes processes and systems. Technological uncertainty associates the manufacturing function to R&D and marketing in the innovation development process. It thus emphasises the necessity to concentrate on the management of such interfaces during high tech product development.

The previously mentioned three main sources of uncertainty – i.e. market, technology and production – can be synthesised in a triangle, the vertices of which refer to the main departments intervening in the high tech NPD process that must collaborate together. This is illustrated in fig. 2.9.

**Fig. 2.9. - The 'magic triangle' of uncertainties and necessary collaborations**

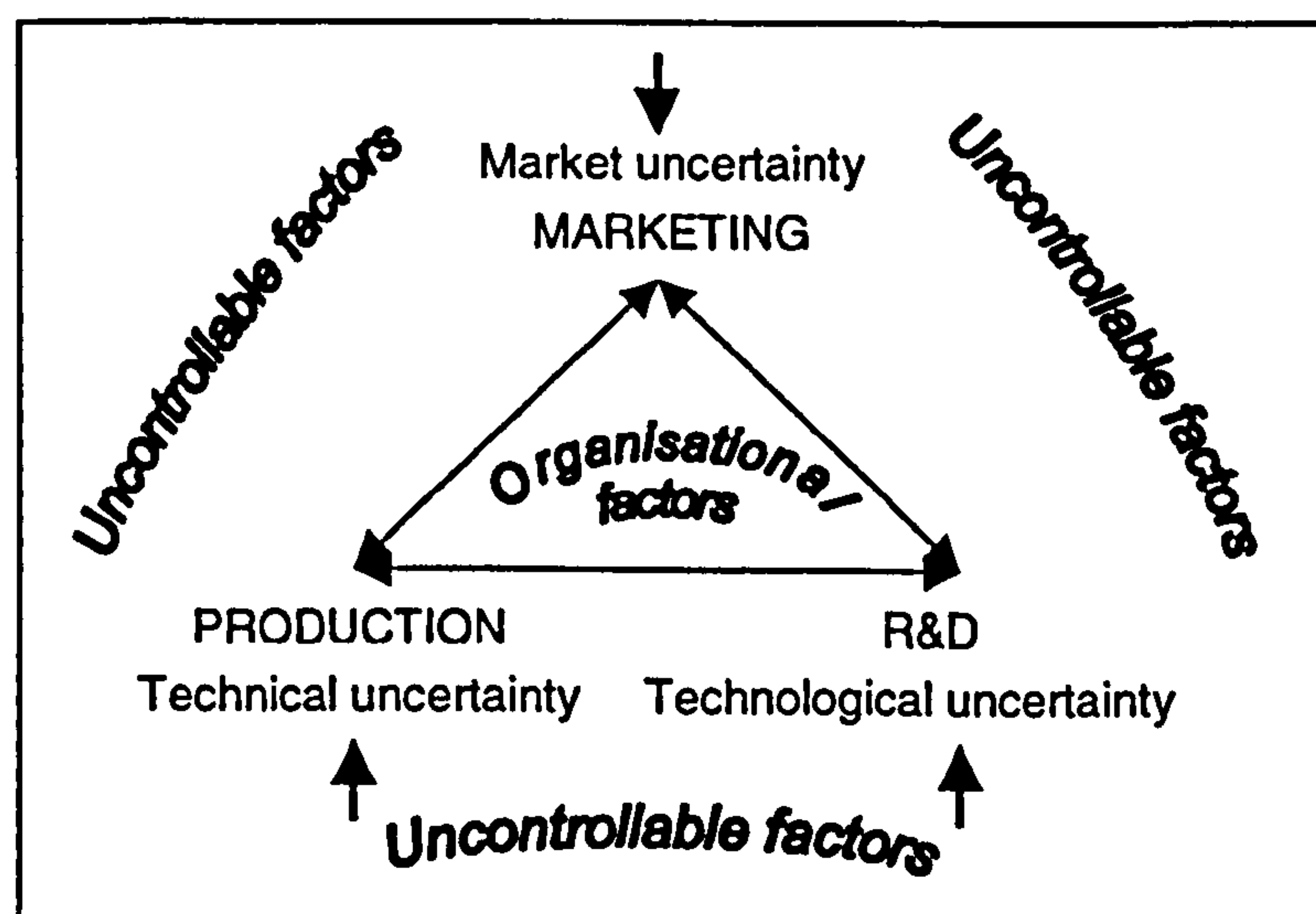



In fig. 2.9., the organisation is submitted to different pressures from its environment. Even though uncontrollable factors come from different sources such as social, political, legal, economic, etc., the figure outlines the three main factors affecting high tech companies – i.e. market, technical and technological uncertainty -. At the centre of the triangle, the organisation has a strategic role to play to:

- identify and evaluate uncertainties – i.e. mainly through its information system -;
- manage them efficiently by co-ordinating the activities of the departments or functions that will directly be affected: marketing, production and R&D.

Consequently, the major point that must be outlined at this stage as concerns high tech companies relates to the strong necessity to implement efficient information systems as well as to adapt organisational and managerial structures in order to reduce uncertainty threats. But this only provides the main frame of the solutions to be considered. Managing in a technology-driven environment is a very challenging task. It implies one main competency which is the ability to evaluate the changes in the environment and to correlate technological feasibility with market segmentation (Price, 1996). And marketing has a decisive role to play.

Therefore, the following section will deal with the characteristics of marketing in a high tech environment.

### **2.4.3. Marketing in high tech firms**

As stressed in the previous sections, the fast-moving nature of markets and technologies in the high tech environment raises many issues as regards the correlation that must be established between the nature of demand and the technology to be launched. Due to the previously described characteristics, marketing in this environment presents differences when being compared with 'traditional' sectors (MacInnis and Heslop, 1990; Traynor and Traynor, 1989). Fig. 2.10. presents the position of high tech marketing as regards technological and market uncertainty.



Fig. 2.10. - High tech marketing

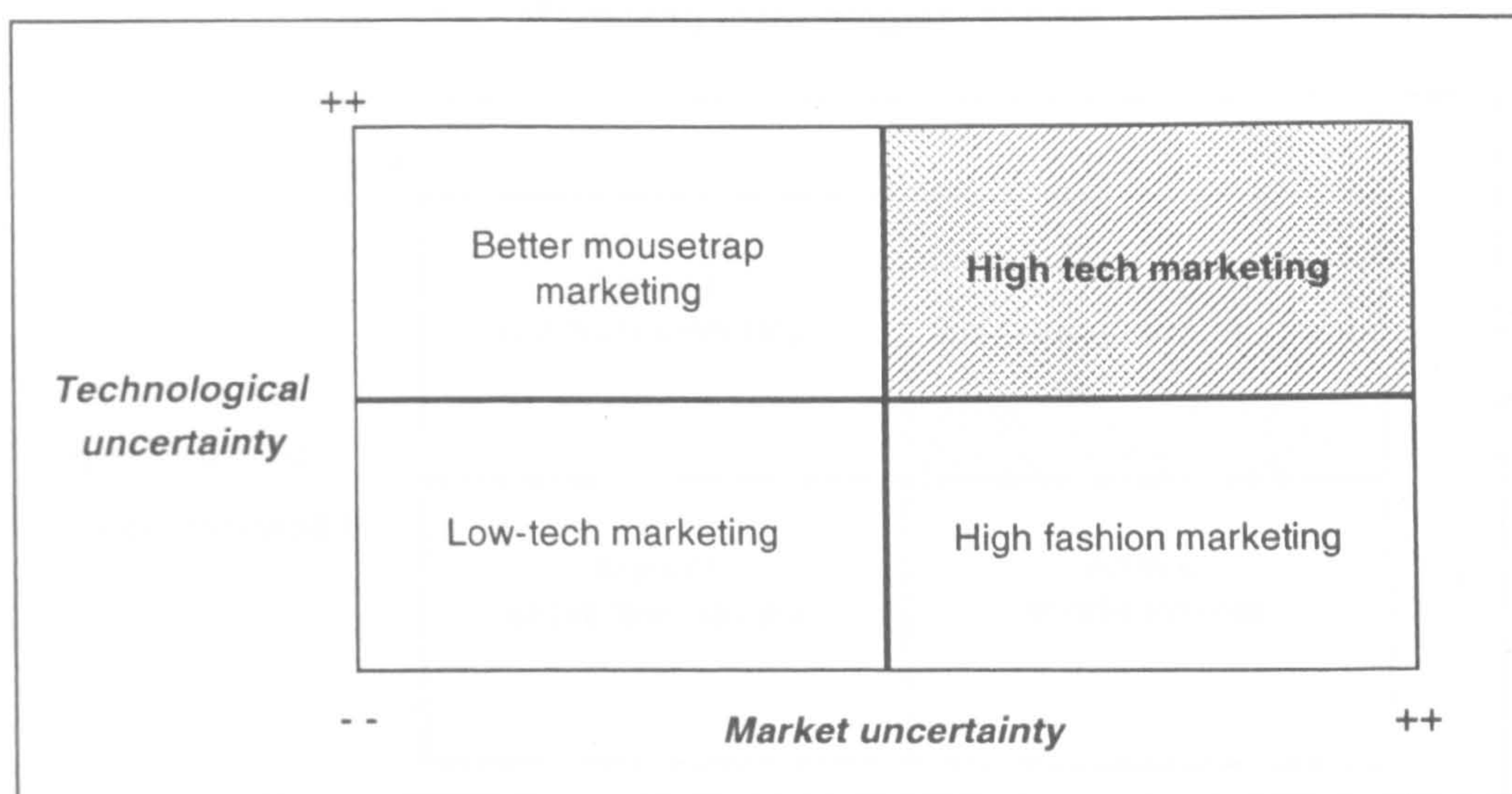

Source: Moriarty and Kosnik (1989)

High tech marketing means having to deal with both the demand and the technology. Planning the evolution of these two aspects and making adequate decisions is the essence of high tech marketing. However, MacInnis and Heslop (1990) have outlined the difficulty to manage high tech products life cycles (PLC) whose evolution will usually differ from non-high-tech products – e.g. high tech products generally experience fast growth once the market is mature -. In order to establish market forecasts, they recommend a parallel follow-up of the technology life cycle (TLC) which will enable to consider potential sales on a longer term. This correlates Roberts (1992) for whom a distinction must be made between technologies that will enable to enter a market and technologies which will ensure competitiveness. According to Millier (1989), managing the technological capital is fundamental within high tech companies. In order to survive, high tech companies must gain new technological knowledge and this is costly. Consequently, they must develop products that sell well and are profitable so as to be able to finance R&D and to increase their technological capital. The role of marketing will be crucial to efficiently manage the 'technology portfolio' and to determine which technologies must be mastered to enter a market or to gain a competitive advantage (Price, 1996).



Fig. 2.11. - Managing technological capital

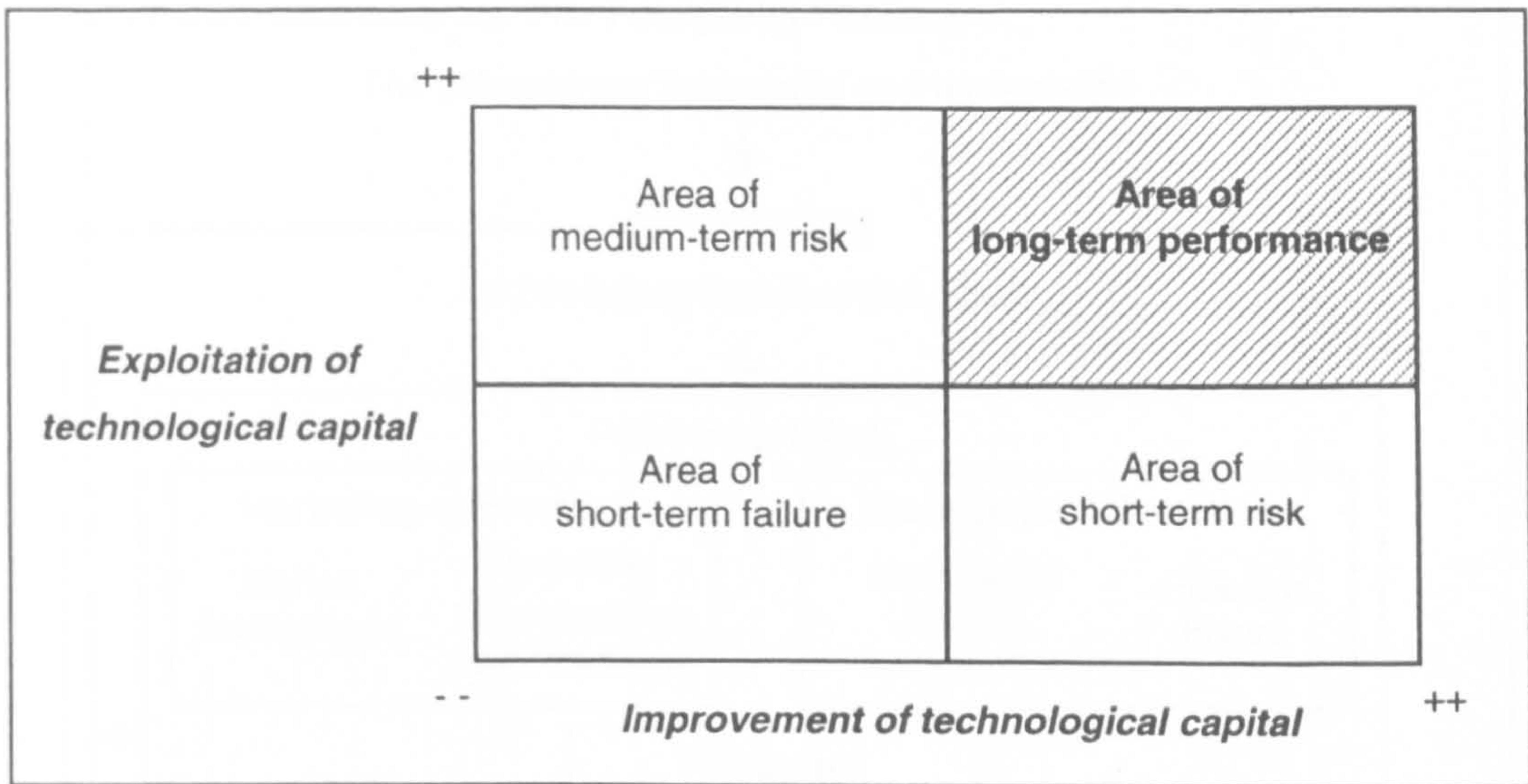

Source: translated from Millier (1989)

Fig. 2.11. also outlines one major aspect as regards the definition of high tech companies. In fact, even though the level of R&D investments can help to categorise high tech activities, it may happen that the weight of technological inputs evolve throughout companies' lives (Millier, 1989). Thus, the main difficulty of high tech marketing will be to manage both existing and future technologies in correlation with market demand. Launching profitable products means responding to market needs, either existing or latent. And here is the added value of efficient marketing. Technology and marketing are strongly linked when considering the firm's survival. Technology alone will not be sufficient to ensure long-term profitability and neither will marketing alone. This was stressed by Roberts (1992) who identified technological inputs as being determining at the founding stage and marketing and managerial orientations as being crucial post-founding factors influencing corporate success, as shown in fig. 2.12.

**Fig. 2.12. - Post-founding factors influencing the success of technology-based companies**

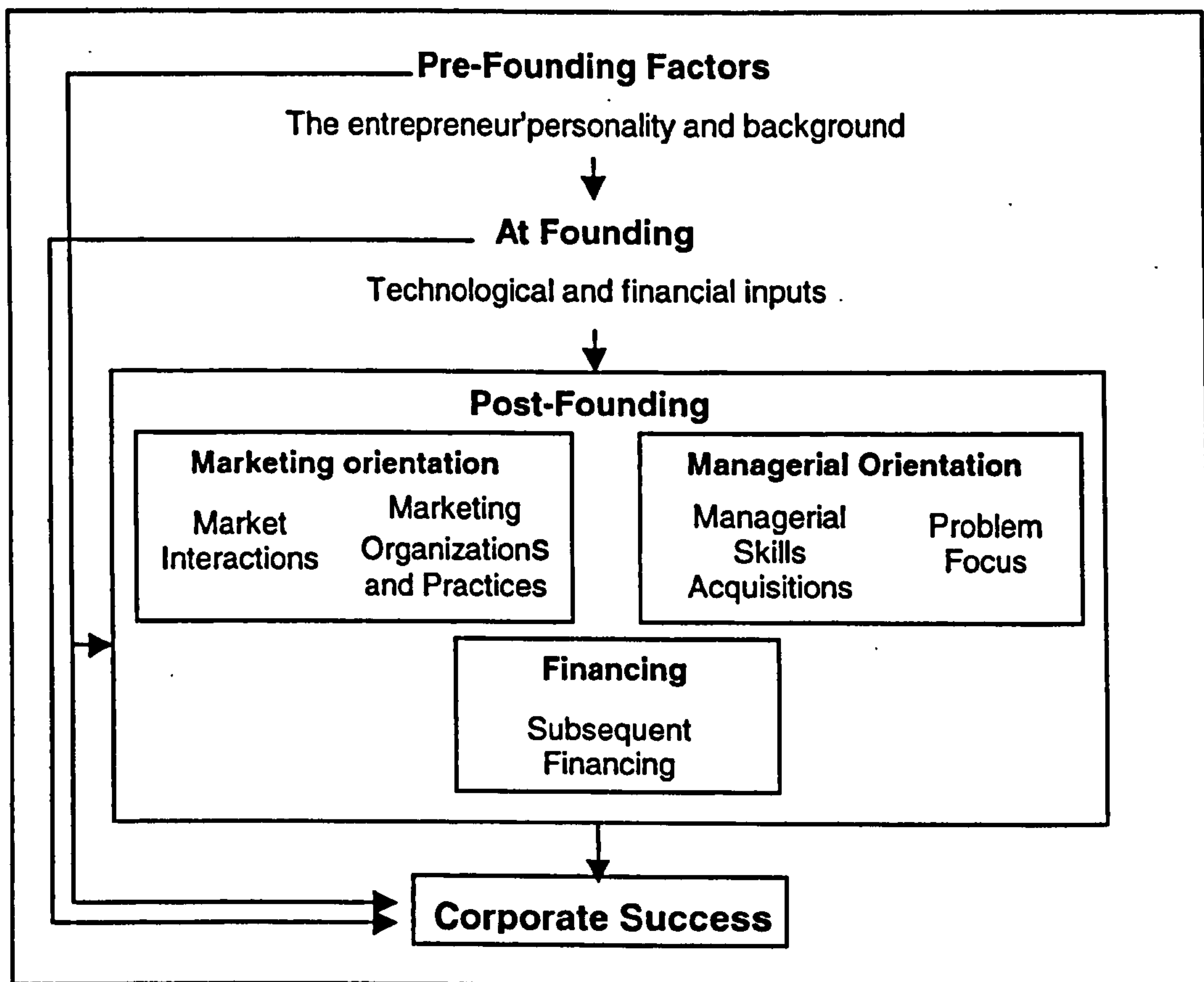

Source: adapted from Roberts (1992)

However, marketing and commercial investments are often too low in high tech firms, leading to a high failure rate. According to Millier (1997), on average, less than 50% of industrial products that have been successfully developed at a technological level eventually become commercial successes. In case of commercial success, the average spreading of investments is: 70% for R&D and 30% for commercial aspects. Millier (1989) also pointed out two main reasons that explain high rates of failures in the technological fields. First, technical and marketing functions rarely work together. This is a crucial issue as regards NPD in high tech organisations. Second, high tech companies do not know how to evaluate their commercial investments. They have no experience relating to the best way of launching a technological innovation on the market. They are used to evaluating technical and material investments – i.e. 'hard' – but they have difficulty to evaluate commercial ones. The lack of marketing resources is also pointed out by Thérin (1998) as a major problem in high tech firms. According to him, there are two main reasons that explain such a situation:



- radical innovations usually sell well among 'early adopters' when launched on the market; consequently, managers frequently think that no marketing investment will be necessary throughout the entire product life cycle;
- as also stressed by Millier (1989), it is difficult to measure return on investment for marketing expenditures, by opposition to other types of more tangible investments.

In addition to the preceding reasons that lead to the restricted role generally played by marketing in high tech organisations, another major factor of failure is the confusion which is often made between the notions of 'technological object' and 'product' (Millier, 1997; 1989). Whereas the 'technological object' will be guided by a mere technological approach, the 'product' will result from the joint work of both technical and marketing services in adequacy with market demand. As stressed by Vogel (1993), the most important difference between 'traditional' and high tech products is that the later are often technology-driven rather than demand-driven, which makes it more difficult to master the nature of demand, especially because most of the time, needs have not already been expressed by the market. Thus, meeting customer requirements will suppose that there is an adequate marketing strategy which will have to be supported by an efficient information system. This will enable the organisation to gain deeper knowledge of both the nature of demand and of the previously mentioned uncertainty pressures.

According to Roberts (1992), "contacting customers to better understand their needs is essential in marketing". Companies should establish early and regular contacts with their existing or potential customers in order to better understand their requirements and translate these needs into product characteristics. This is even more true for high tech marketing. The existence of a marketing department in the initial stages of a high tech firm's life will increase the chances of success. So will the involvement of customers throughout the NPD process, from the earliest stages of pre-development activities to product launch and market follow-up. This can take different forms going from direct exchanges – e.g. integrating customers in NPD - to well-established market and organisation interfaces through the information system.

Consequently, the major point that characterised high tech marketing is the complexity of implementing marketing strategies in a context of heavy technological inputs. As regards

organisational aspects, the R&D/marketing interface will also require particular attention, especially since these two functions generally evolve in a context of disharmony.

#### **2.4.4. Disharmony between R&D and marketing: how to increase integration?**

Managing in a technological environment supposes to link science, engineering, marketing, production and all the managerial disciplines of the organisation so as to be able to formulate a strategy and to develop the necessary technological competencies to reach these objectives (Price, 1996). However, with the notions of 'technological object' versus 'product', Millier (1989) clearly outlined the opposition that often exist between technical and marketing functions and emphasised the necessary collaborations that must exist between these departments. As mentioned by Gupta et al. (1986), "both R&D and marketing have developed stereotypes of the other, which act as barriers to effective integration". These barriers are detrimental to success (Souder, 1981).

As regards the origins of such disharmony, the main point to be outlined when considering high tech companies is that most of them are founded by engineers who are, by definition, very technology-driven (Bouvard, 1998). Their managerial approach tend to be scientific and mostly quantitative. However, the counterpart to their technological/scientific educational background is that, in most cases, they have reduced knowledge about managerial and business aspects. On the opposite, marketing people tend to be, by nature, more qualitative in their approach. These differences between R&D and marketing people are now emerging as a major difficulty to be managed in the expanding high tech sectors (Chevalier, 2000). Moreover, as stressed by Monck et al. (1988) marketing is especially difficult for highly technological companies. In fact, they often have to estimate a market that has not already emerged and for which well-defined needs are not expressed. Furthermore, the firms are faced with the traditional managerial and organisational problems but rapid growth makes them even harder to manage. In short, the high tech environment makes marketing and management tasks quite difficult and, furthermore, the lack of marketing and managerial skills makes things worst. In fact, in a large majority of companies, the activity originally started on the basis of a new technology that could be quite easily sold to identified key customers. And, frequently, it is only when competition gets tough – i.e. during the maturity stage of the product life cycle - that managers consider developing their marketing structure (Bouvard, 1998).



But, at that point, it is generally too late to turn the firm's culture into a marketing, or better, market-oriented one. Eventually, this situation often paves the way for non-existent, superficial or conflicting relationships between R&D and marketing teams - e.g. lack of interaction, lack of appreciation and distrust – characterised by reduced communication and confidence between the two functions (Thérin, 1998; Souder, 1981).

As stated by Gupta et al. (1986), the R&D/marketing interface is one of the most crucial ones, especially in contexts of high uncertainty. However, for different reasons, mainly relating to individual factors, R&D and marketing functions usually evolve in a context of disharmony, thus creating a gap between the perceived need for integration and the degree of integration actually achieved – see fig. 2.13. -.

**Fig. 2.13. - The integration gap**

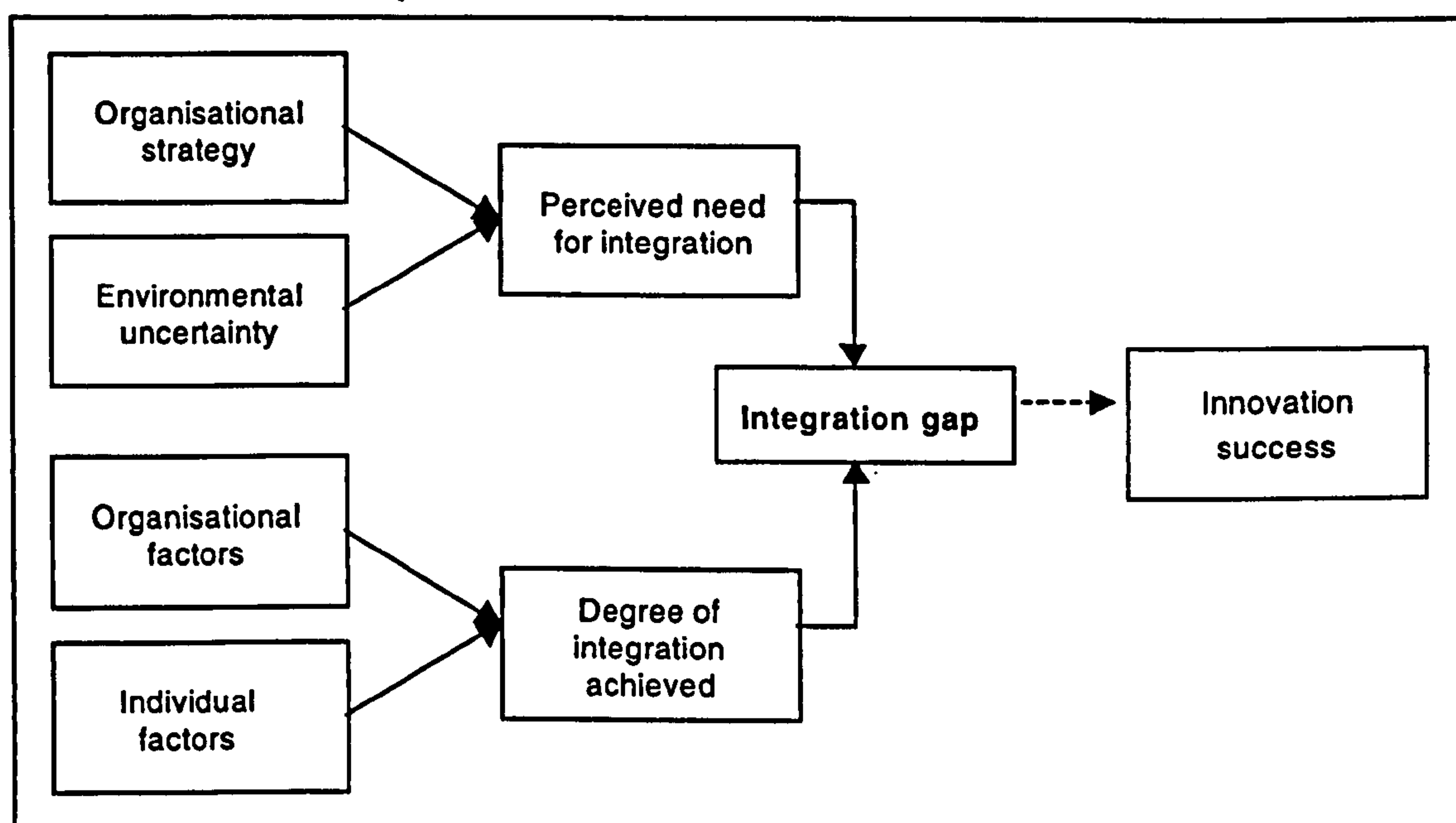

Source: Gupta et al. (1986)

According to Gupta et al. (1986), the wider the gap between the perceived needs for integration and the actual degree of integration achieved, the lower the probability of innovation success. In fig. 2.13., the 'organisational strategy' relates to the corporate degree of reactivity as regards new markets and technologies – i.e. going from very proactive companies to more passive companies -. The need for integration will evolve in parallel with the degree of pro-activity and risk taken by the organisation. 'Environmental uncertainty' concerns competition, consumers, technological evolution and regulatory constraints. The need for integration is proportional to the level of uncertainty

perceived. 'Organisational factors' relate to the type of structure – e.g. centralised, formal, collaborative, etc. -, to the managerial environment and to R&D/marketing operating characteristics. Integration will be positively influenced by low formalism and concentration of power, high employee participation and risk taking as well as by harmonious operating characteristics. Finally, 'individual factors' include socio-cultural differences between R&D and marketing managers. The greater the similarity and the higher the level of integration. Thérin (1998) also studied the question of integration between R&D and marketing. According to him, the reduction of integration barriers will be influenced by efforts made by management, R&D and marketing as shown in fig. 2.14.

**Fig. 2.14. - How to overcome integration barriers**

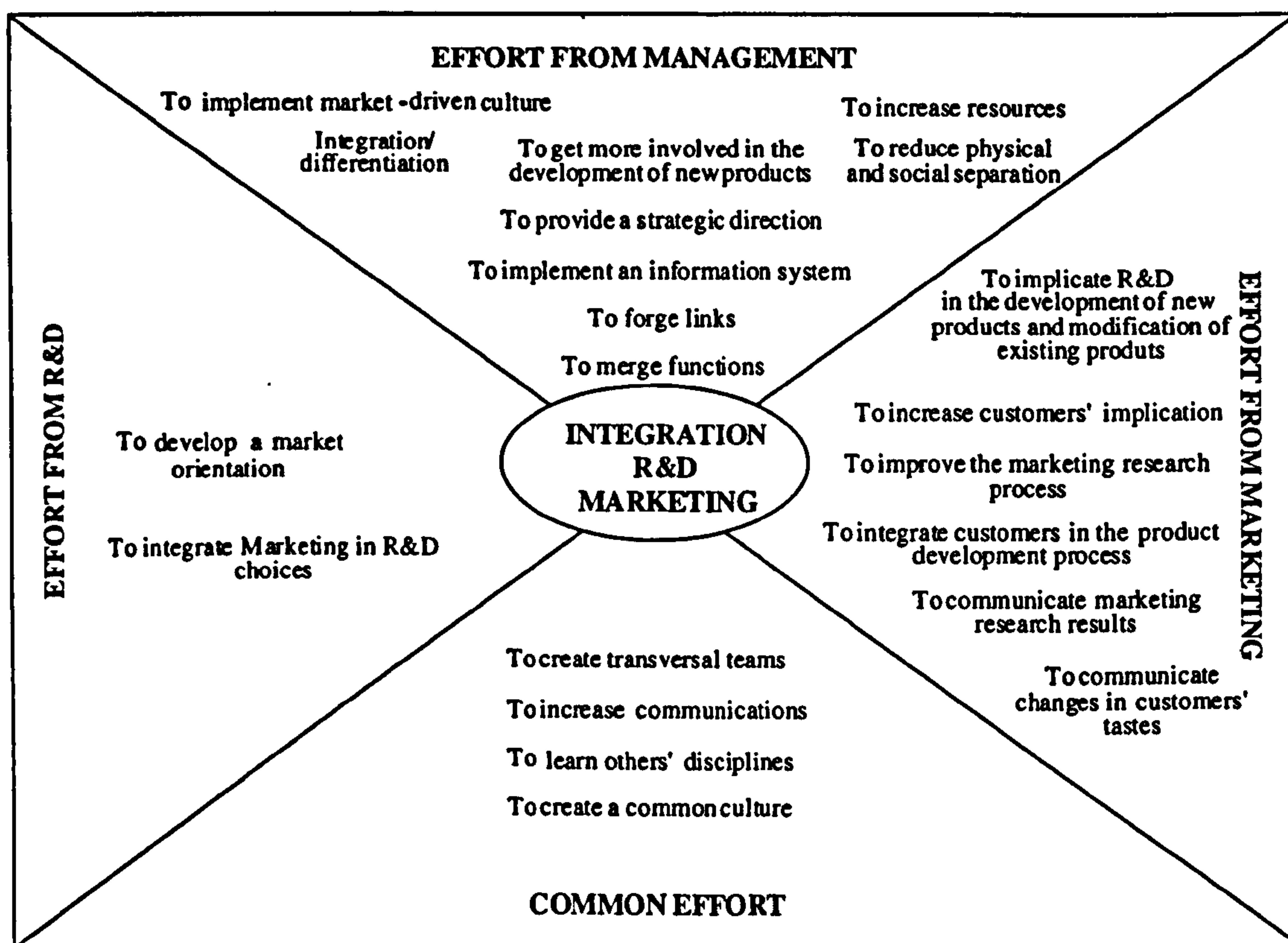

Source: translated from Thérin (1998)

In fig. 2.14., strategic directions set by top management, adequate resources, cross-functional exchanges and customers' integration in the NPD process are key factors to increase R&D/marketing integration. This is emphasised by Viardot (1994) for whom implementing a demand-driven culture within a company implies a collaboration between all the departments and especially between R&D and marketing. However, this organisational link must be initiated by the management, which supports Thérin's figure in which "effort from management" is placed at the top



of the integration process. According to Viardot, managers in high tech companies should ideally be hybrid people, able to deal with both internal and external aspects such as: R&D, finance, marketing, production, competition, technological environment, etc. More concretely, they must be willing to favour the implementation of a demand-driven culture within their organisations which initially requires that they provide a strategic direction. Thus, managers are responsible for setting a guiding vision, based on customer requirements, which must be shared by the whole organisation.

This means:

- implementing efficient communication so that the strategic direction is conveyed throughout all the departments;
- getting more involved in NPD, so as to be able to modify orientations when necessary;
- and to control that exchanges between departments actually happen. Management is also responsible for favouring trans-functional exchanges by merging functions, increasing resources and reducing distances (Thérin, 1998; Souder, 1981)

However, apart from management, it is also necessary that R&D and marketing make efforts to improve integration.

As concerns R&D teams, it means, among other things, gaining marketing knowledge in order to be more sensitised to market demand - i.e. "to develop a market orientation", mentioned in the left part of the chart -. However, it seems that the counterpart is missing in fig. 2.14., in which the "effort from Marketing" section should also mention the necessary understanding of technical aspects on part of marketing and other non-technical teams. And, according to Moriarty and Kosnik (1989) who took the example of the computer industry "teaching functional specialists what they need to know about computers is easier than teaching computer scientists the intricacies of consumer loans or public-sector accounting". Even though this might be true for sectors in which basic technological aspects can be quite easily integrated by marketers, this must be moderated when considering sectors with heavy technological inputs, which require deep professional skills. Ideally, both R&D and marketing departments should be knowledgeable of the main bases of one another's disciplines.

As regards marketing, much effort must be made to increase the understanding of customer requirements, mainly by improving the marketing research process and customers' integration in NPD. Moreover, the information obtained must be shared with R&D in order to work on a common

basis – i.e. what the customer wants -. Finally, both departments should make efforts to increase trans-functional communication and create multidisciplinary teams. In fact, according to Souder (1981), one characteristic common to the companies in which R&D and marketing are equal partners, is the proactive and early involvement of both departments in the NPD process. Moreover, in these cases, the marketing personnel is technically trained with some previous experiences in the R&D departments.

However, as mentioned by Jassawala and Sashittal (1998), integration should be wider than marketing/R&D interface and should concern the whole organisation. In fact, when taking into account the high level of technical uncertainty of the high tech environment – i.e. the manufacturing feasibility of product concepts – production should also appear in fig. 2.14. Efforts as regards interfaces should mainly come from management, R&D, marketing and production. Moreover, according to Jassawala and Sashittal (1998), a distinction must be made between integration and collaboration. As for them, collaboration is “the next generation of cross-functional linkage relevant to NPD processes”. They consider that collaboration is based on more intensive and productive cross-functional linkage.

#### **2.4.5. Key-findings and conclusions**

Different points have emerged as regards the characteristics of the high tech business environment:

- **Uncertainty as regards:**
  - markets;
  - technology;
  - production.
- **The need for good information management so as to reduce risk by gaining better knowledge of external environment including customer requirements.**
- **The need for a market-driven guiding vision set by management and shared by the whole organisation.**
- **Efforts from R&D and marketing to create interfaces, mainly by increasing communications and create cross-functional teams but also the integration – or even better, collaboration - of production, which is also threatened by uncertainty;**
- **The early and proactive involvement of R&D, production and marketing in NPD.**



This chapter has emphasised the different characteristics of the high tech environment which will impact on NPD. First, companies are threatened by three main levels of uncertainty: market uncertainty, technological uncertainty and technical uncertainty. As regards NPD, this implies, in priority, high reactivity, good management of the information system, and upstream collaborations of R&D, marketing and production so as to reduce the time to market and be able to consider the different constraints that will impact NPD as early as possible. However, integration between departments, and especially R&D and marketing, is not an easy task. Disharmony is frequent, either at a mild level or at a severe level. In fact, each function generally has its own objectives and culture. R&D is mostly technology-oriented and marketing is more linked to the market. Thus, interfaces need to be improved. At this level, the role of top management is essential in order to set clear objectives and to provide the organisation with a guiding vision that must be the unique reference shared by everybody.

The conclusions of the preceding sections are synthesised in fig. 2.15. The next sections will be dedicated to design management and to the role it can play in managing NPD processes.

Fig. 2.15. - Issues relating to NPD in high tech organisations

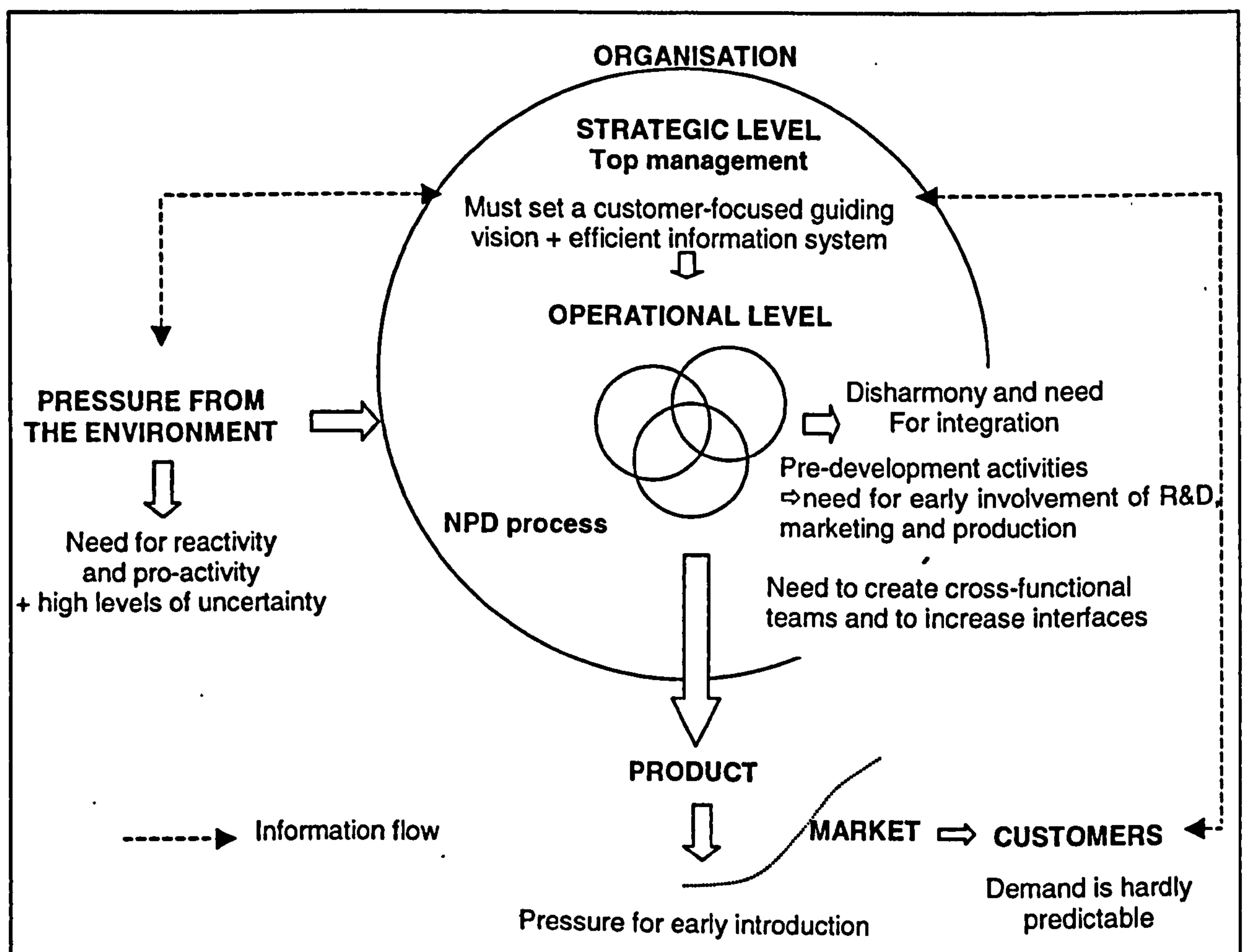

## **2.5. Design and design management**

### **2.5.1. Introduction**

The preceding sections have provided an overview of existing literature relating to NPD and to the characteristics of the high tech sectors. This part will examine relevant research concerning design management. The first section will focus on design in France. It will be followed by a definition of the concepts of design and design management. Then, a synthesis of relevant pieces of research relating to design strategies and to the design process will be provided.

### **2.5.2. Design in France**

Design has experienced difficulty to emerge among the French companies. According to Lemens (1994) and Tissier-Desbordes and Fialho (1994), this is due to different factors. First, design is often seen as an artistic issue without any link with commercial matters. Second, it is difficult for manager to categorise design and to clearly understand its strategic role. In fact, design is perceived as relating to different issues such as R&D, marketing, communication and this leads to a vague perception of the benefits that it can bring to companies. Consequently, these confusions make managers think that implementing a design strategy is a complex process that they could hardly deal with. Eventually, in such a context, designers have hard time imposing their approaches and skills in the business environment.

Despite this context, different studies have been conducted in France, mostly by governmental organisations, as regards the role of design in the French companies. A major study was published in 1995 by the French Ministry of Industry. This descriptive study concerned about 600 small and medium size French industries (SMSFI). It revealed that one out of three SMSFI uses design but that only 16% of them do it regularly. In fact, industrial design mostly concern consumer goods and household equipment. Among the advantages of using design that the SMSFI stressed are:

- it brings a competitive advantage through innovation and differentiation;
- it contributes to develop firms' cultures internally and externally;
- it is a profitable investment;
- it enables to communicate on subjective or psychological variables.



Moreover, the study showed that SMSFI using design launch about three times more new products than the ones that do not use design (DARPMI, 1995). In 1998, and on the basis of the 1995's survey, another study about design strategy was conducted by the French Ministry of Industry. Its main objective was to determine how design strategies may impact on international development. The conclusions of this report clearly stated that even though design appears to provide strong competitive advantages, it is still weakly present among French industries. One main recommendation, here, is that design be integrated in the upstream stages of the NPD process as well as at the upper decisional levels (Anselin, 1998).

### **2.5.3. The wide spectrum of design activities**

'Design' comes from the Latin word 'designare' which means 'to mark with a distinctive sign'. In the 18th century, the word 'design' was already well-established in England but it was only adopted in France in the 1960's (Laurent, 1999). In French, 'design' is the association of two ideas: aim (*dessein*) and drawing (*dessin*), i.e. it associates the idea, the project, and its representation (Laurent, 1999; Fayolle, 1998; Gaté, 1998; Schulmann, 1991). According to Gupta (1994), design designates and distinguishes the product. However, the term 'design' is rarely understood (Grundy, 1995; Mallick et al., 1993) and covers a wide range of concepts and activities (Loosschilder, 1995; Tissier-Desbordes and Fialho, 1994; Walsh et al., 1992; Bauhain-Roux, 1992):

- design management: see section 2.5.3.3.;
- product design: that links engineering design, responsible for 'function', industrial design, in charge of 'fit' and human resource design, or ergonomics, in charge of 'form';
- industrial design: development of concepts and specifications that will combine the requirements of both users and manufacturers and that will mainly concern mass-produced goods;
- engineering design: the process that validates the technical feasibility of a product concept and determines how to provide the required 'functions' for a product;
- packaging design: that will concern the 'envelope' of the product;
- graphic design: that mainly relates to visual identity and communication aspects;
- interior, architectural and environmental design: mainly relating to the firm's external and internal facilities and equipment – e.g. buildings, rooms, sales outlets, workshops -.
- fashion and arts design: relating to textiles, footwear, crafts, jewellery.

### **2.5.3.1. What is design?**

As stressed by Walsh et al. (1992) "design means different things to different people" and the understanding of the design activity is often limited to some specific issues. First, design must not be limited to the mere notion of aesthetics or style, even though the associations, and confusions, between design, arts, styling or decoration are still frequent (Tissier-Desbordes and Fialho, 1994; Bauhain-Roux, 1992). This was also emphasised by Gupta (1994) and Schulmann (1991) who insist on the fact that design does not only concern products' external characteristics – i.e. aesthetics - but also structural and functional aspects that will turn the product into a coherent unit. Aesthetics must not be considered as an objective of the design process but rather as a means that will enable companies to reach strategic objectives and gain market shares (Gaté, 1998). Jones (1991) and Fayolle (1998) also stressed the fact that design is not only making something look attractive. Design is "intrinsic" and "implies a research about both content and form".

Like aesthetics, the definition of design must not be limited to the notion of ergonomics. However, it remains a decisive factor in building relationships between the product and its users – i.e. the man-machine interface -. As stressed by Grundy (1995), the main role of design is "to improve products from the human aspect". Ergonomics will be based on the knowledge issued from different disciplines including psychology, sociology, anthropometrics, etc. This will play a major role in considering the trans-functional and / or collaborative role of design.

According to Gaté (1998) "design is a creative activity with both industrial and commercial aims. It helps the company to formulate its offer. It also helps to make choices while opening new development ways". Thus, design is a way of multiplying the firms' technical and marketing capacities. According to Suresh Babu (1995) "design is the use of scientific principles, technical information and imagination etc. in the development of a product or mechanical structure or a machine or a system to perform pre-specified function with the maximum economy and efficiency". This definition is quite close to the ones given by Trueman (1998) and Crotty and Pamplin (1993) for whom design is the creative process that includes planning, decision making and the management of activities focused on market needs which must lead to product performance, usability, aesthetics and value for money.



The role of design and the components it covers are wide. However, as stressed by the previous definitions, one major aspect concerns its strategic implication for organisations.

### **2.5.3.2. The strategic role of design**

Different authors have stressed the strategic role that design can play to gain a competitive advantage (Briard, 1999; Cooper and Press, 1997; Whitney, 1988). For instance, Cooper and Press (1997) emphasised design as a strategic resource to implement a differentiation strategy and enter niche markets or to build a coherent international image. Walsh et al. (1992) stressed the strategic role played by design as a link between an invention, a market and manufacturing capacities. This is also emphasised by Cooper and Press (1997) for whom “as a process which bridges the desires of the market with the potential of production, design clearly has a strategic dimension”.

However, this strategic dimension must be assimilated and clearly emphasised into the corporate culture and strategy and initially be communicated by the Board. When building a design strategy, they must set how the company is going to use design to reach its objectives (Woolley, 1999, Cooper and Press, 1997). Consequently, design must be part of the overall vision set by senior managers. It is their role to define the meaning of design for the company and how design will participate in the company's operations. Moreover, by integrating middle managers from different functions in the definition of the design policy, it will then be owned by the whole organisation.

Thus, design concerns function and form but also has wider strategic implications. This contribution in emphasising product characteristics and in creating an interface between different skills, needs and objectives is particularly decisive for the present research. The question is ‘how can design be implemented and developed to emphasise its integrating role within high tech companies operating in France?’. The notion of design management developed in the next section will lead to a better understanding of the practical implications of design as regards NPD.

### **2.5.3.3. Design management**

The term 'design management' appeared in the mid 60's. However, according to Press (1995) and Cooper and Press (1999), it was in the 80's that design management became a political matter in the United Kingdom and was emphasised as a competitive weapon in a context of "free market orthodoxy". Even though these authors consider that, for these historical reasons, the term 'design management' may not be adapted to the present economic context, other researchers believe that it is still relevant in today's context and have provided different definitions of this concept.

Crotty and Pamplin (1993) defined design management as "the strategic management of innovation which aims to guarantee a coherence between the company's objectives and the different market needs through three main areas of activity, namely product, market and technology, using multi disciplinary teams". This provides different elements that will impact on the present research. First, the notion of corporate objectives is determining. It is the first step that will guide design management and that will affect its efficiency. Then, in the context of high tech products, the link between market and technology will be a source of concern and one of the research question is to analyse the impact that design management will have to develop the interface between markets and technologies. Finally, the use of multidisciplinary teams will require organisational, managerial and more generally cultural changes that will undoubtedly impact on corporate structure and, thus, require further investigation. The role of design management as a transversal function linked to almost all the departments of the company was also stressed by Hetzel and Wissler (1997), Faust (1993) and by Mallick et al. (1993) for whom "better integration of engineering, industrial, and human factor design expertise is a major challenge of design management". This is a decisive aspect when considering the research questions.

Thus, design management is a matter of both creativity and organisation. However, some researchers, including Cooper and Press (1999) consider that these two ideas are contradictory. According to them the term 'design management' covers two conflicting notions – i.e. respectively risk taking and control - which threatens the innovative nature of design. This issue was also raised by Richardson (1995) who mentioned "the dichotomy, that management and design find themselves in today". According to him, design and business refer to opposite principles, i.e.



qualitative versus quantitative values. The question asked by Richardson is “how design can survive in a numbers-driven environment?”. However, as stressed by Anderson et al. (1993), “design and management is ultimately about people” and one can argue that balancing creativity and predictability so as to turn them into an efficient strategy will be the role of managers.

In fact, as stressed in the next sections, when implementing the design strategy in an organisation, the different managerial levels will have to collaborate.

#### **2.5.4. Efficient design management and design strategy**

Researchers have studied different factors that will lead to efficient design management and design strategy. However, before making decisions about the design strategy to be implemented, a design audit may be useful so as to make a diagnosis of the situation and evaluate the actions to be taken.

##### **2.5.4.1. The design audit**

According to Crotty and Pamplin (1993), the design audit may help managers to understand the strategic implications of design management. The main aim of this audit is to look at the company's objectives and to make recommendations as regards its design. The design audit will be based on three main parts: corporate issues, project management and design and will, thus, enable to analyse the role of design at the different organisational levels.

The design audit can also be the first stage of collaboration between a company and external designers. In fact, in order to provide adequate service – i.e. a service that fits company's strategy and objectives – designers must know about the opportunities and threats that surround the firm as well as about its strengths and weaknesses. Such a prospective analysis gives managers the occasion to gain knowledge about their macro and micro environments as well about their internal abilities. It enables to determine the key factors of success (Cegarra and Hetzel, 1997) before implementing a design function and initiating a design strategy. However, such decisions suppose that top management has previously understood the strategic role of design.

#### **2.5.4.2. Implementing efficient design strategy**

According to Cooper and Press (1997), all the managerial levels will have to participate in the implementation of the design strategy. Senior managers are responsible for setting the corporate vision and strategy and to ensure consistency with design strategy once it is made a strategic point. However, the involvement of senior managers in piloting programmes and projects will depend on the size of the organisation (Cegarra and Hetzel, 1997). As for middle managers, they participate in policy making and manage implementation. They are responsible for developing the necessary structures from participation in design strategy to the evaluation of outcomes. At a functional level, designers and design managers are in charge of managing design from the scanning and communication of design trends, including competitors' design strategy and customers' needs, to the final evaluation of design.

From an organisational point of view, strong design emphasis supposes that there is a specific structure dedicated to design (Woolley, 1999; Walker, 1993). This means having either a design department, a design manager or to collaborate with external consultants. However, in most cases, design is a function which is directly subordinated to marketing, production or even communication since it has a role to play with all these functions (Tissier-Desbordes and Fialho, 1994; Walsh et al., 1992). The problem with such a subordination is that the role of design as a catalyst and neutral co-ordinator of the NPD functions will tend to be moderated since the design team will be influenced by the department from which it depends. Moreover, the notion of subordination, in itself, supposes that design is not considered as a priority. On the contrary, the fact of appointing a manager responsible for design together with building a clear design entity within the organisation are strong evidences of support for design (Dubosc, 1999; Cooper and Press, 1997).

From a managerial point of view, efficient design requires inter-functional links for a better integration throughout the whole product development process. The different departments as well as managerial levels must be sensitised to the strategic role of design. These leads to the third aspect, i.e. the necessity of a corporate culture that will value design strategic implications. In fact, this directly depends upon senior managers who are responsible for initiating and developing such a culture. Walker (1993), uses the metaphor of "the soup, the bowl and the place at the table" to describe the creative process, the management structure and the managerial vision that must



guide efficient corporate design policy. In his article, he outlines that the creative process – i.e. 'the soup' - is based on different components, including creative individuals, small teams and a right mix of skills through multidisciplinary co-operation. Thus, efficient design management will be based on different key factors.

First, there must be a strong involvement and commitment of the highest hierarchical levels in supporting design (Cooper and Press, 1997; Walker, 1993; Beckwith and Harris, 1993; Whitney, 1988; Olins, 1985). This support supposes human and financial resources as well as procedures to pilot the design structure. Thus, design must be integrated in upstream resource allocations and budgeting, and then, downstream, be monitored with cost and time records that will enable forecasting for future projects. The necessity to maintain the loop of evaluation, planning and development in order to increase design efficiency was stressed by Cooper and Press (1997) and Burnette (1993). In fact, evaluation will be decisive to inform the development process and to progress as regards design management. Evaluation must integrate different aspects such as customers' perceptions of the product, but also internal and external contributions to the process as well as the assessment of the return on investments.

Thus, heavy managerial support is the first step in implementing and monitoring an efficient design strategy and guiding the organisation towards success. However, it is not the only factor. Walker (1993) focuses on different key elements that lead to efficient design, among which multiple connections, informality, non verbal techniques and a shared culture emphasising corporate identity were mentioned as critical factors. According to Walker, the least interference is the best way to maintain productive pressure within creativity teams. Middle management must provide a solid framework that will guide design processes but without destructive criticism and hierarchical pressure – i.e. "a transparent bowl" -. It is the best way to maintain and develop innovative synergy within the organisation. An adequate organisational structure was also stressed by Cooper and Press (1997) for whom "a creative and design sympathetic climate, which involves informal and lateral interaction, and communication between design and all other functions" will favour successful innovation and design. According to them, "structures which encourage organic management style, team work and frequent communication between design and all other functions and levels, have been identified as the best for supporting and maximising the use of design". Multidisciplinary teams are clearly considered as favouring such interactions. Moreover, design

itself will favour inter-functional exchanges by creating common bases of reference. Eventually, attention must be focused on the market with a clear managerial vision of users' needs as well as future trends – i.e. “the place at the table” -. This supposes an efficient information system to feed in the design process (Walker, 1993). The link between design and the information system will be developed in section 2.5.12.

However, as stressed by Roy et al. (1999) and by Woolley (1999), successful design is not dependent one factor but on a combination of different elements which supposes cultural and structural adaptations within companies. Integrating design into the corporate culture was identified as the initial step to implement a design-oriented strategy (Roy et al., 1999; Woolley, 1999; Trueman, 1998). Woolley (1999) outlined four main stages that will guide the development of an industrial design culture. These stages are presented in fig. 2.16.

**Fig. 2.16. - Developing an industrial design culture – bridge building**

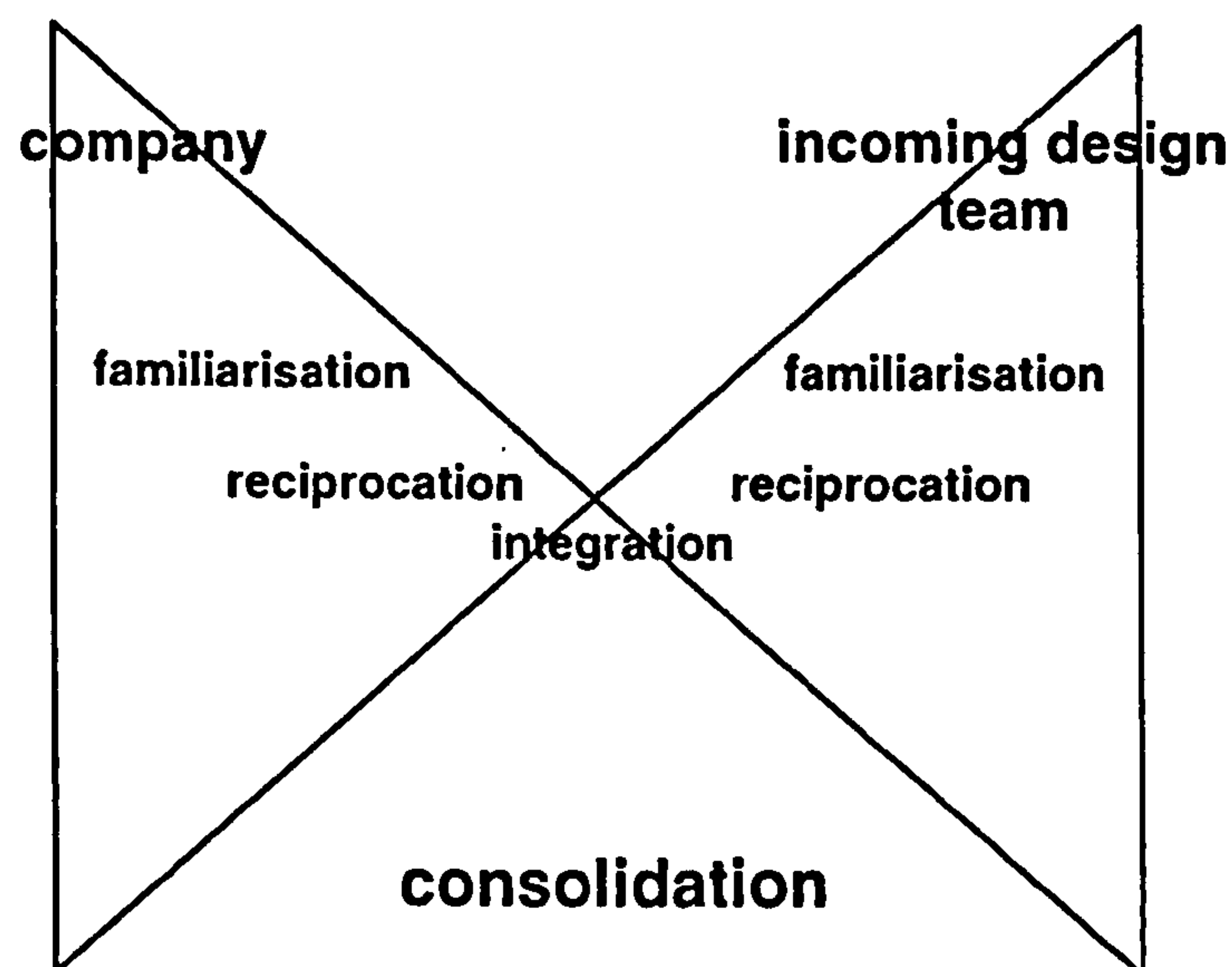

Source: Woolley (1999)

The four phases identified by Woolley are: “familiarisation” – i.e. the stage at which both the designer(s) and the company increase their awareness of one another -, “reciprocation” – i.e. the stage at which the company and the designer(s) exchange information -, “integration” – the design tasks are integrated in the NPD process, and more globally in the management structure -, “consolidation” – i.e. the ultimate stage at which the different functions fully collaborate to meet common strategic goals -. Such collaborations suppose that the organisation has adopted a transversal NPD process.



### 2.5.5. The transversal approach versus the traditional linear NPD process

Whitney (1988) defined design as “a company-wide activity”. The transversal role of design was also emphasised by Trueman (1988) for whom even though the role of design may seem more obvious at the concept stage of new products, it also has a central role to play as regards problem solving during actual NPD – see table 2.5. -.

**Table 2.5. - Key design attributes**

<b>STRATEGIC LEVEL</b> Strategic activity Corporate culture
<b>NPD PROCESS</b> Idea generation Interpret ideas Ideas communication Integrate ideas Reduce time-to-market
<b>PRODUCT</b> Product identity Brand creation Product styling Aesthetics Product quality Added value
<b>MARKET</b> Differentiate products Competitive tool

Adapted from Trueman (1998)

In table 2.5., design is a central element throughout the whole NPD process as well as in the very upstream and downstream stages. These was also emphasised by Cooper and Press (1997) and Cegarra and Hetzel (1997) who stressed the role of design upstream of the NPD process, to identify market needs and during the NPD process, to solve technical problems, get manufacturing costs down, create an appearance right for the market and sometimes reveal NPD inefficiency.

As shown in fig. 2.5., from the strategic level to market launch, design will impact on many organisational aspects. First, it will suppose that top management clearly support the

implementation of a design-focus strategy and that the organisation is guided by a coherent design policy. Second, it will require that designers are well-integrated in the design process. This integrating role that design management can play to co-ordinate the different functional input was stressed by different authors and especially by Cooper and Press (1997), Faust (1993), Borja de Mozota (1993), Schulmann (1991) and Burnette (1993) for whom the work of designers supposes to collaborate with various functional divisions throughout the whole NPD process – e.g. engineering, manufacturing, marketing, distribution, users, etc. -.

However, such an integration supposes a well adapted internal organisation, or structure, and a managerial approach that encourages cross-functional communication. Moreover, different barriers still limit the role of designers in the NPD process. First, as stressed by Anderson et al. (1993), design education has been weak in terms of developing interfaces with business. According to them, training designers so as to develop their management knowledge has often been seen as an obstacle to creativity. However, the authors, as well as Jones et al. (1993) and Cegarra and Hetzel (1997), consider that a holistic approach of the design process is a major advantage to understand the problem – i.e. customer requirements and business strategy - in the very upstream stages of product development and to provide adapted solutions without heavy implications in terms of time and cost. This holistic approach was also stressed by Suresh Babu (1995) for whom “modern thinking suggests that the design process is only complete when it has been extended to include everything from original thought right through product, assembly, packaging, storage and even final distribution to the ultimate customer”. Design, in that case, is seen as an integrating function, linking the different steps of product development. As mentioned by Topalian (1994), “effective design is integrated and integrating design”.

To support the transversal integration of design, computer-aided techniques will be of tremendous importance in linking all the disciplines that are involved in the NPD process (Loosschilder, 1995). This will be developed in the next section.



### **2.5.6. Design and visualisation**

Design cannot be separated from the notion of visual communication (Topalian, 1994; Walsh et al., 1992). Throughout the entire NPD process, from the graphic ideation to prototyping and elaboration of the marketing mix, designers will sketch forms, make drawings and models, transform concepts into computerised pictures or prototypes. As stressed by Loosschilder (1995), Temple (1994) and Beckwith and Harris (1993), sketches are an essential tool for the designers and visual representations are the way by which designers will express their ideas and mental images and then be able to communicate them. This was also emphasised by Miller (1999 a), for whom visualisation is a crucial factor in product data management (PDM). In fact, being able to visualise product representations will help users in manipulating information and making decisions as regards the project they manage. Design management has a major role to play at that stage (Miller, 1999 b).

Information technology (IT) and computer-aided techniques provide effective support as regard the design process. As stated by Loosschilder (1995) and Woolley (1999), IT will act as a design facilitator since it will lead to more efficient information sharing, increase the speed of communication and help simulation and visualisation with the opportunity of high realism. Computer-aided design (CAD) will be particularly helpful for creating realistic concepts and modifying, simulating, analysis and evaluating design proposals. In the concept-testing stage, visualisation tools such as CAD will facilitate consumer evaluations and direct interactions between the designer and the potential buyer. This will finally lead to a sharper definition and representation of customers' requirements. However, the benefits of CAD are not limited to the concept stage. Techniques such as rapid prototyping will also be helpful when it comes to the manufacturing – e.g. visualisation of spare parts and components or production of moulds -. Moreover, even though CAD will be helpful for any type of NPD, the high degree of realism provided by computer-aided techniques will be even more helpful for complex and highly innovative products (Loosschilder, 1995).

### 2.5.7. Design and products

According to Evans (1985), "products are becoming pieces of applied knowledge manifesting need, lifestyle, values and aspirations. New methods and processes in design make products more tailored, adaptable and desirable to the consumer. Some Japanese companies are describing this shift as the 'humanware age of design'". The main objective of design as regards the final product will thus be to harmonise product features and customers' requirements.

Product positioning or identity is based on different components which are shown in fig. 2.17. and that can be classified in three main categories: use, interfaces and image (Schulmann, 1991). 'Use' will include all the different factors relating to the way the product can be employed. 'Interfaces' are all the functions that interact with users – e.g. keyboards, buttons, screens, etc. -. 'Image' covers all the variables that will position the product in customers' minds and that communicate about the product identity. In fact, as stressed by Loosschilder (1995), design not only embodies the product's technical function but also emphasises social and cultural aspects directly linked to the very nature of consumer behavior.

**Fig. 2.17. - Product-related data**

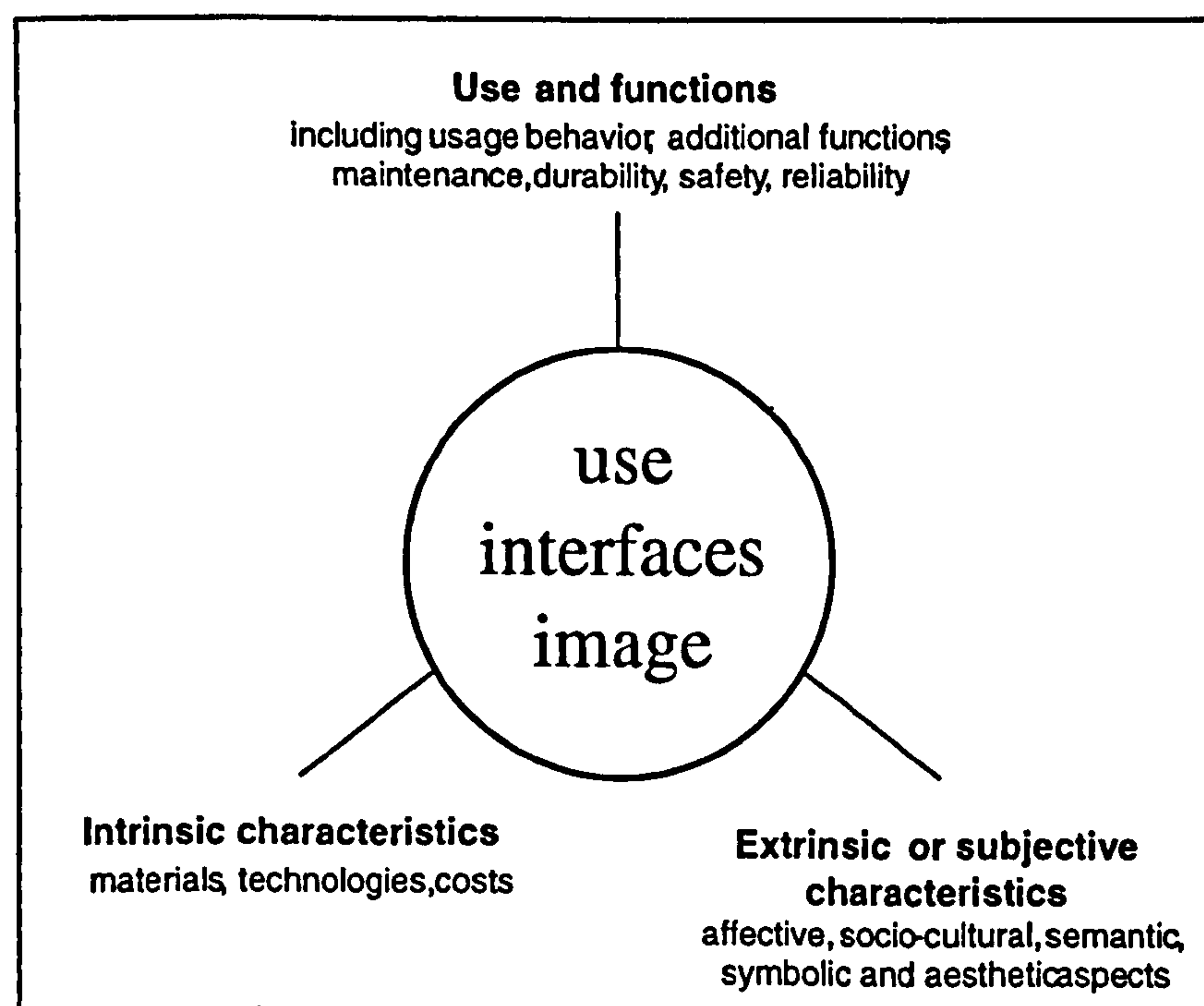

Source: adapted from Schulmann 1991



Design will enable the organisation to communicate on these different aspects, emphasising either objective/material dimensions – i.e. use, functions, technical characteristics - or subjective aspects relating to the image. Eventually, this will determine product features (Thölke, 1994) and contribute to add value to the final product (Tissier-Desbordes and Fialho, 1994). As stated by Woolley (1999), “the visible attributes for a product do not exist *per se*”. Some important characteristics of the product may need to be reinforced and made visible so as to reassure the buyer. However, Woolley also insists on the fact that the visual identity must match the actual product performance, without adding superficial and inappropriate attributes since this would definitely lead to customers’ disappointment. This will be particularly important when considering product launch on the market and the associated marketing strategy to which design will contribute. The product external characteristics and what it communicates must match the targeted customers and be coherent with the marketing mix.

Moreover, the above-mentioned data conveyed by of the product are critical when analysing the NPD process and the inputs of the different department. Intrinsic characteristics of the product, for instance, will concern the R&D (technological input) but also the production (materials, costs) as well as the marketing department that will have to compare these characteristics with customers’ expectations and then communicate about product positioning. According to Woolley (1999), the symbolic aspect is often neglected in sectors manufacturing ‘functional’ and technology-driven products and there are “fears that a superficial ‘appliqué’ would detract from the essentially functionalist attributes of the product that denotes durability, safety and reliability”.

So, marketing, R&D and production will be associated in developing the use, interfaces and image that corresponds to product positioning as defined by the organisation. As stressed by Thölke (1994) “the choice of which features to include in a new model is a result of a complex negotiation process”. In this context, design management will act as the necessary link between corporate strategy and culture, management, R&D, marketing, production, customers and products. It will provide some kind of ‘dynamic frame’ in which product development activities will take place. As mentioned by Temple (1994), “the place of sketching during the design process can be understood as a visual dialogue or argument between opposing points of view, changing in its detail by small increments until a satisfactory outcome is reached”.

In this context, concept testing will be of tremendous importance to evaluate the degree of product's acceptance by the potential buyers during the NPD process. "A concept is a representation of the product design idea, which is generated in an early stage of development" (Loosschilder, 1995). When concept testing is implemented, the concepts that have emerged from the idea generation stage are submitted to a sample of potential customers. These customers are asked about their opinions concerning the design, both quantitatively and qualitatively, the objectives being to select the best concept, to estimate the future market potential and to consider possible improvements. At that stage, computer-aided techniques will provide strong support to visualise products' concepts (see section 2.5.6.).

### **2.5.8. R&D and design**

The strategic link that exists between design and R&D was stressed by different researchers (Cooper and Jones, 1994; Tissier-Desbordes and Fialho, 1994; Walsh et al., 1992). According to them, these two disciplines are at the heart of technological innovations and are crucial factors in the development of new products. Design deals with forms, components and materials while R&D focuses on new manufacturing processes, technical improvements, etc. Together, design and R&D constitute fundamental inputs in NPD. Moreover, in high tech companies, technological know-how is a strategic weapon that will guarantee the firm's survival (Millier, 1989). Ideally, the final product must reflect technological performance and communicate about technological features. At this stage, the design strategy is a critical issue. It must help choosing the features that will be enhanced and then find ways to emphasise technological inputs which are often intangible (Thölke, 1994, Tissier-Desbordes, 1994).

But the role of design is not limited to emphasising technology, even though this will contribute to convey the added value incorporated in the final product. As mentioned by Feldman (1995), design will also enable to increase user-friendliness and thus reduce the reluctance to adoption that high tech products often generate - what the author calls the "demands-to-satisfaction ratio", i.e. the efforts that end-users will have to make in order to become familiar with the new product -. By focusing on users' needs and emphasising the human dimension of the product, design will limit psychological resistance and reduce the period of adaptation and (Franzén et al., 1995). The fact of creating and emphasising customer values throughout an appropriate design strategy is known



as user-centred or user-oriented design (UCD/UOD). As stressed by Franzén et al., it has been developed at a slow pace in industrial markets, compared to mass markets. However, it has now become a key issue. Table 2.6. synthesises the changes that have occurred as regards industrial markets.

**Table 2.6. - The new and the old situation for industrial markets**

	<b>Old situation</b>	<b>New situation</b>
<b>Focus</b>	cost efficiency	value for the customer
<b>Goals</b>	profit through volumes	profit through customer satisfaction
<b>Characters</b>	standardised products high quality is value added long product life cycle	customised products high quality is absolutely required short product life cycle
<b>Organisation</b>	functional	team-based, project-oriented

Source: Franzén et al. (1995)

The changes listed in the table above stress that customer-focus has become a priority for industrial markets and that form and function must be integrated so as to enhance quality with a concern for human needs. The impact of design at this stage is essential.

However, associating technology and creativity is not an easy task and different authors have stressed that quantitative and qualitative priorities may be difficult to manage (Cooper and Press, 1999; Richardson, 1995; Wilson, 1993). A main concern at the managerial level will be to eliminate the cultural boundaries that separate these functions by setting a guiding vision that will emphasise human needs as a priority. Designers will have to understand the added value provided by technological know-how (Cegarra and Hetzel, 1997) whereas R&D will have to recognise the role of designers in enhancing customer's benefits in high tech products.

In addition to the previously mentioned issues, marketing will also play a major role as regards customer focus. However, as outlined by Franzén et al. (1995) marketing and design is not always a self evident combination in practice.

### **2.5.9. Marketing and design**

Design and marketing have always been closely linked. As stressed by Loosschilder (1994), "design is often regarded as an important tool for marketing strategy, to establish the company's competitive position as well as to satisfy consumer needs". Moreover, as mentioned by Tissier-Desbordes and Fialho (1994), design directly relates to the final product and the product is an element of the marketing mix. Thus, the two disciplines are dependent upon one another. This was also emphasised by many researchers (Anselin, 1998; Loosschilder, 1995; Walsh et al., 1992) for whom innovative design must be accompanied by efficient marketing so as to lead to success. Cooper and Press (1997) also stressed the close link that exists between design and marketing in any organisation. According to them, "marketers are wedded into the design process to ensure that market factors inform design decisions".

Even though industrial design can be associated with the beginning of the Industrial Revolution – i.e. second half of the 18<sup>th</sup> century – it really appeared as a competitive advantage in the 30's, due to the 1929's economic crisis. At that time, industrials needed a new resource to face a decline in the level of consumption. Design was seen as a way to stimulate the volume of sales (Cooper and Press, 1997). Today, design still interacts in different manners with marketing and will help responding to different challenges, among which enhancing product features and product differentiation, better adapting to customers' requirements, increasing user-friendliness, building a consistent corporate identity, etc (Feldman, 1995; Franzén et al., 1995; Tissier-Desbordes and Fialho, 1995; Loosschilder, 1994; Thölke, 1994; Bauhain-Roux, 1992). The interaction between marketing and design will be essential throughout the entire NPD process and in the downstream stages of product launch so as to harmonise the design, marketing and communication strategies and, eventually, to develop a coherent product mix. Collaboration and exchanges of information will be essential between design and marketing to identify both objective and subjective factors that characterise the nature of the demand and the stimuli that will impact on customers (Revat, 1997). Integrating the end-user in the upstream stages of the design and innovation process will be a key factor of success (Walsh et al., 1992). Firstly, because it enables to gain better knowledge of the market. Secondly, because it provides sources of user-initiated improvements which increase the chances of success. Finally, because these "experts" are opinion leaders who will support product



launch – i.e. ‘early adopters’ – even though they may not be representative of the mass market. More than anything else, the challenge is to maintain effective communication between the market, the technical, design and marketing teams. At that stage, market research and computer-aided design (CAD) will be central elements to manage the interfaces between the different actors participating in the NPD process.

#### **2.5.10. Communication and design**

The role of design has recently emerged in books dedicated to communication (Tissier-Desbordes and Fialho, 1994). However, the link between the two is of tremendous importance. Just as for the marketing mix, the communication strategy must be coherent with both the design approach and the corporate identity adopted by the organisation. According to Van Rekom (1997), corporate identity can be defined as “the set of meanings by which an object allows itself to be known and through which it allows people to describe, remember and relate to it”. As stressed by Melewar and Saunders (2000), the notion of corporate identity goes further than mere design. It encompasses all the factors that will influence the way people perceive a given organisation. Managing such factors requires co-ordination and coherence so as to avoid sending multiple messages as regards corporate identity, in an environment which is already saturated by thousands of brands (Kotler and Dubois, 1997). Global design will help building a coherence between the different design components of the firm – e.g. products, packaging, visual identity, etc. – (Gaté, 1998). Everything that represents the company will have to reflect corporate unity (Melewar and Saunders, 2000). Design will create common references and will, thus, favour exchanges on common bases (Cegarra and Hetzel, 1997). But, initially, design will have to be clearly valued in the corporate culture and this is the role of senior managers.

As stressed in the preceding sections, design will impact on different corporate functions such as R&D, marketing and communication. It will also play an essential role as regards production.

#### **2.5.11. Production and design**

The role of design as a service aimed at both end-users and internal customers – i.e. other corporate functions – has been stressed by different authors (Borja de Mozota, 1993; Mallick et al.,

1993). Exchanges between design and production are critical during the NPD process (Cooper and Jones, 1994) and, quite often, design is associated with efficiency of manufacturing (Whitney, 1988). Thanks to computer-aided techniques, and when being incorporated upstream of the product development process, design will help to improve manufacturability (Mc Dermott and Stock, 1994). The use of CAD applied to manufacturing takes different names: design for manufacturability (DFM), design for assembly (DFA), design for economic manufacture (DEFM), product design for assembly (PDFA), design for automation (DFAn) but, as mentioned by Mather (1992), Peskin and Adis (1993) and Tatikonda (1994), the objective is the same for all these terms: to reduce delays and costs by making products easier to manufacture. More precisely, according to Tatikonda (1994), "DFM describes a class of techniques to improve product manufacturability for all types of products, not just assemblies". As for Venkatachalam (1992), the design for manufacturability process intends to optimise and simplify product and process concepts during the design phase of a product so as to ensure ease of manufacture as well as improved quality and reduced manufacturing costs. "Design for assembly is a subset of design for manufacturability" (Tatikonda, 1994). It is a systematic analysis process principally aimed at reducing the assembly costs of a product by simplifying its design and reducing the number of parts.

According to Venkatachalam (1992), as well as Tatikonda (1994), a major part of the manufacturing costs of a product is determined during the design phase. The upstream exchanges between design and manufacturing have a determining impact on the production stage as well as on product competitiveness. This is also stressed by Vasilash (1994) for whom manufacturing constraints must be integrated in the earlier stages of the design process, especially thanks to inter-functional teams gathering manufacturing, industrial and design engineers, and, if possible, other people from the marketing, purchasing and finance departments. The determining role of cross-functional communication – together with extensive databases - is also stressed by Tatikonda (1994) as a factor of success for implementing successful DFM techniques.

However, apart from the internal organisational aspects directly relating to the NPD process, design will also be a way of valuing technical or manufacturing inputs in the final product. Features such as solidity, durability, ease of repair or perceived quality, for instance, can be enhanced by adequate design (Thölke, 1994). This is another reason explaining why the manufacturing



department will have to be integrated in the early stages of the NPD process together with the design team.

As shown in the previous sections, design will be involved at the different stages of the NPD process and will impact on different functions. However, efficient design requires much information both about internal organisational aspects – e.g. constraints of manufacturability, technological know-how, etc. - but also relating to the external environment – competitive products, customers' requirements, etc. -. Thus, design is directly dependent upon the information system.

#### **2.5.12. Design and the information system**

According to Hetzel and Wissler (1997), the development of information systems has required more flexibility to keep on adapting to new data and more interactions are now necessary for efficient information sharing. Design will be heavily dependent on the information system which must be fed by marketing (Walsh et al., 1992). In the upstream stages of the NPD process, information about the environment of the firm, the market, customers' requirements, as well as about the firm's capacities will be needed in order to develop a coherent design policy. This stage is defined as the prospective or exploratory design study by Cegarra and Hetzel (1997). As outlined by Gaté (1998), the creative process "will start by collecting a maximum amount of information: on the company, its history, its know-how, its technical, financial and commercial capacities, its sector and the other fields that may influence it". As for Walsh et al. (1992), they emphasise that successful companies exploit various sources of information. Moreover, Cegarra and Hetzel (1997) insist on the fact that information must be both qualitative and quantitative, concerning, for instance, the size of the market but also the nature of competition as well as the behaviours of the targeted customers. Walsh et al. (1992) and Borja de Mozota (1993) insist on the fundamental role of end-users in feeding the information system and being sources of creativity and improvement for the marketing and design departments. However, they also outline the risk of becoming dependent on a unique source of information with a totally reactive, rather than pro-active, approach. What is important is that such preliminary research enables managers to better define the market requirements and to obtain a consensus on which to base future product development work. At that stage, design will help to formalise the data collection process, both on the firm's environment and on its end-users.

Downstream of the NPD process, the product must be evaluated and this evaluation, once collected, must also feed the development process (Cooper and Press, 1997; Borja de Mozota, 1993). As mentioned by Cegarra and Hetzel (1997), design can be compared to an information system that will help decision-making. In fact, integrating design within the corporate strategy supposes to gain knowledge about the firm's external and internal environments so as to develop well-adapted and well-positioned products. Even though capturing external information is crucial, Phillips and McDonnell (1999) also stressed the importance of keeping and managing the information generated throughout the entire design process so as to benefit from a learning curve effect for the following NPD. In fact, they postulate that it is often difficult to understand the rationale behind designers' decisions and that there is usually no record to be used as future references. Keeping traces of the information that have emerged throughout the NPD process will enable to build a knowledge structure that will serve future decisions and contribute to feed internal culture.

Cegarra and Hetzel (1997) also emphasised both the organisational and managerial dimensions of design. Design, as a factor that will provide common references for the different functions intervening throughout the NPD process, has a federative role. It also helps trans-functional co-operations. Burnette (1993) confirmed this statement by mentioning the integrating role of design, which can provide "sharable forms of displays" – e.g. drawings, prototypes, etc. – that will be understood by the whole organisation, as well as by potential users, thus favouring common sources of exchanges and an homogeneous understanding of corporate objectives. Quite often, it will also reveal the inefficiency of the NPD process.

However, research has also outlined that communication between designers and users is often weak, thus leading to inappropriate interpretation of customer requirements. As stated by Bolton and Williams (1995), "the key problem is that the user and the designer often only communicate through the product itself", thus not really understanding what the authors call "the 'why factor'" – i.e. the nature of interaction between users and objects -. Moreover, according to these authors, identifying both latent and explicit user needs require multiple information sources and the design process must act as a catalyst and central function. In connection with different sources, user-centred design (UCD) will enable to generate information relating to: users, information requirements, needs and problem parameters, as shown in fig. 2.18.



Fig. 2.18. - Framework for generating user centred information

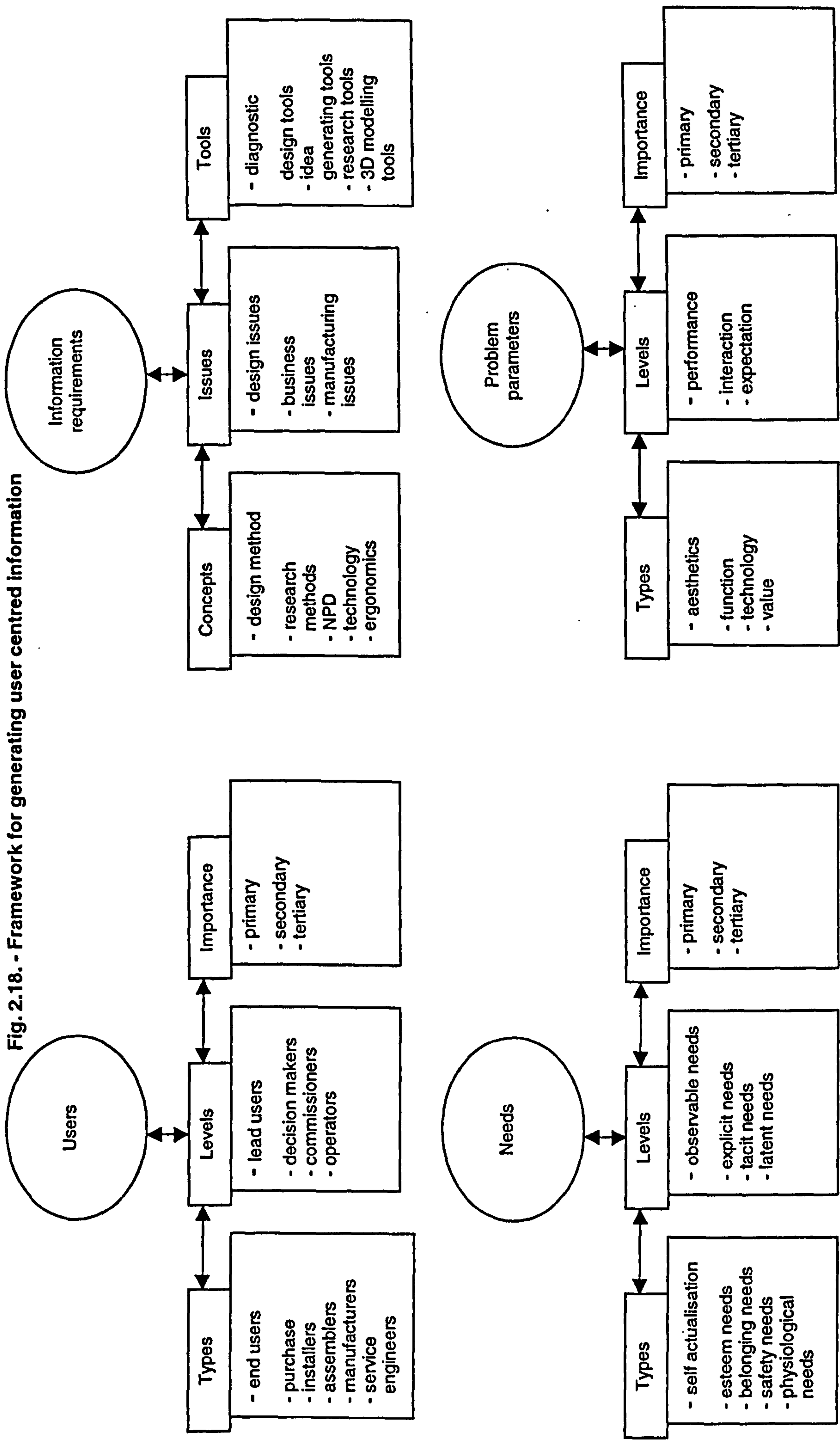

The main objectives behind UCD are to enable users both to communicate their needs and to participate in the NPD process but also to be able to interpret these needs into concrete design concepts. In parallel with the core components identified in fig. 2.18., the product design process will also address business and manufacturing issues. All these factors – i.e. users, needs, information requirements, problem parameters, business and manufacturing issues - will interact with one another in the product design process, the final objective being to gain more accurate information about user needs and to integrate this information in the NPD process as well as in the final product. As stated by Grundy (1995), designers are increasingly looking for deeper understanding of the people they are designing for. Consequently, the relationship between design and the information system becomes crucial to organisations.

As stressed in the previous sections, design will enable the organisation to emphasise the added value incorporated in the final product and enhance the quality perceived. Analysing the relationship that links design and total quality management (TQM) is, consequently, another important element to be taken into account.

### **2.5.13. Design and total quality management (TQM)**

As defined by Borja de Mozota (1993) “total quality management is a set of concepts and practices for enhancing customer (internal and external) satisfaction by providing higher quality products and services. Quality management implies collectively guaranteed signs that products, services or organisations will meet customer’s expectations”. These guarantees can be of two types: product or service certification – e.g. the Norme Française or NF – or organisation certification – e.g. the International Standard Organisation (ISO) norms -. According to Borja de Mozota, TQM and design share the same goal: to improve customer’s satisfaction. However, there tends to be a frontier between the two due to the fact that TQM will mainly be concerned with the quality measured and design with the quality perceived. According to Antoine (1994), “there is a duality that opposes engineers and designers” concerning quality. As stressed by Sethia (1994), TQM values quantifiable and concrete quality, whereas design will value “a higher-quality quality”. However, these differences can be complementary and mutually reinforcing one another since design can help emphasising the quality actually incorporated into the final product.



As far the NPD process is concerned, Borja de Mozota (1993) suggests that quality measures could benefit designers since they would gain better knowledge of the impact of design on product manufacturability and product quality – i.e. satisfaction of internal and external customers -. In parallel, designers can act as actors and integrators in the quality management process by “improving quality” and “conveying the new values of the organisation”. In fact, since the central role of both design and quality is to increase customer satisfaction, they cannot be dissociated. As mentioned by Sethia (1994), “the winning strategy for offering the customer a positive experience leading to felt high satisfaction involves shifting the focus from Quality Management to Design Management”. This implies that the company’s design and quality strategies are coherent and that design excellence conveys the corporate quality values. However, Antoine (1994) outlined that by opposition to quality standards which are often imposed by external actors, the design strategy can only be initiated internally.

#### **2.5.14. Synthesis of findings and conclusions**

The following factors have emerged from the previous sections:

- **At the corporate level:**

- design must be part of the overall vision set by senior managers;
- the design audit may help managers to understand the strategic implications of design management;
- strong design emphasis supposes that there is a specific structure dedicated to design (design department or design manager and that design is not subordinated to any other function within the company;
- corporate objectives have to be clearly set and shared by the whole organisation in order to increase design management efficiency;
- there must be a consistency between corporate objectives and design strategy;
- the corporate culture must value design strategic implications
- design will help the organisation building a consistent image;
- designers can act as actors and integrators for the quality objectives

• **At the managerial and functional level:**

- the different managerial levels will have to collaborate in design management;
- the least interference is the best way to maintain productive pressure within creativity teams.  
There must be a solid framework that will guide design processes but without destructive criticism and hierarchical pressure;
- design management, as a transversal function, will require and enable to develop inter-functional links. The "rugby approach" (Walsh et al., 1992) will prove more efficient than the sequential approach;
- in the upstream stages of NPD, design will help to formalise the data collection process, both on the firm's environment and on its end-users but it is necessary to integrate customers in the upstream stages of the design and innovation process;
- design will create common references and will, thus, favour exchanges on common bases;
- design will also contribute to gain feedback in the downstream stages;
- design will play a major role in the manufacturing process, especially through the use of DFM techniques;
- informality and non verbal techniques will favour exchanges;

• **At the product level:**

- design will enable to communicate on either objective/material dimensions – i.e. use, functions, technical characteristics - or subjective aspects relating to the image. In the technology-pushed sectors, design can help to enhance R&D input;

In the preceding sections dedicated to design, it has been stressed that design will enable organisations to build a consistent corporate image and to communicate on the product's main dimensions, emphasising either objective/material dimensions – i.e. use, functions, technical characteristics - or subjective aspects relating to the image. Design has a role to play in communicating R&D input, helping technical feasibility and materialising customers' requirements. This supposes a heavy dependence upon the information system but design will also help formalising such a system since it will require efficient environmental scanning and customer-related data. It supposes that these customers are integrated in the early stages of design, innovation and NPD.



Design management is a strategic function with transversal implications. From a managerial point of view, efficient design requires inter-functional links for a better integration throughout the whole product development process. Concurrent design will favour closer relationship and exchanges between the different functions participating in the product development process. So will informality and non verbal techniques. In fact, design will create common references and will, thus, favour exchanges on common bases.

But at the basis of any design-oriented strategy, it is necessary to have a corporate culture that will value design strategic implications. This requires that the different managerial levels collaborate and ensure consistency of the corporate vision with the design strategy. However, the least interference is the best way to maintain and develop innovative synergy within the organisation. Management must provide a solid framework that will guide design processes but without heavy hierarchical pressure.

From an organisational point of view, strong design emphasis supposes that there is a specific structure dedicated to design and that design is not subordinated to any other function. However, as stressed by Roy et al. (1999), investing in design and NPD will not be the only conditions to reach business success. It the synergy between different factors – e.g. management attitude towards design, investments in research, design and development, technical innovation and NPD as well as quality standards - that will ensure company growth.

As stressed by Tissier-Desbordes and Fialho (1994), design will impact on the final object or product by emphasising its structural dimensions, on the end-users, on the different functional levels of the company, especially R&D, production and marketing, and on corporate identity.

These different factors are synthesised in fig. 2.19.



Fig. 2.19. - Impact of design management on the NPD process and necessary adaptations

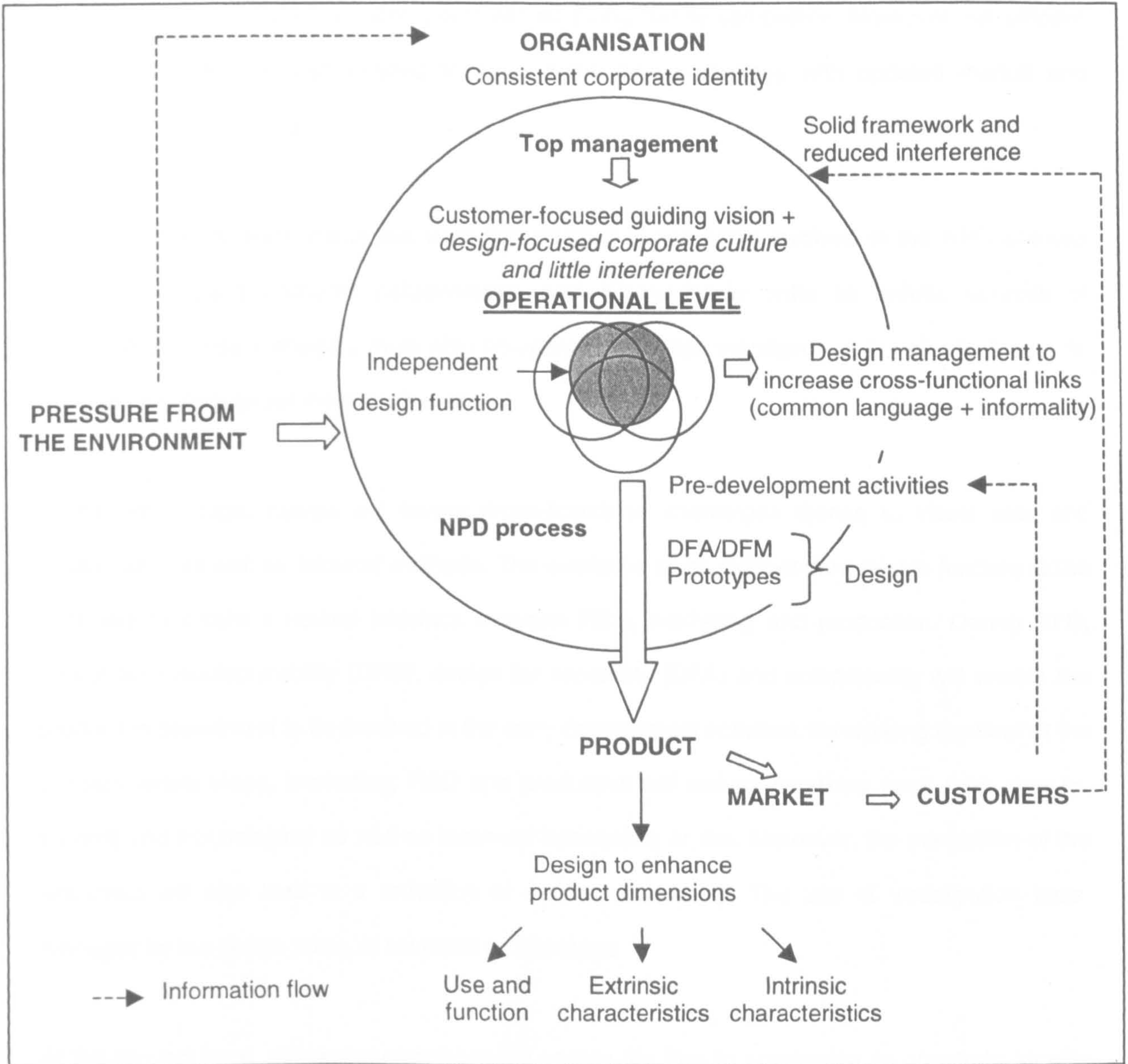

## 2.6. General conclusions of literature review

The issues that were derived from the different sections of the literature review, respectively relating to NPD, to high tech sectors and to design management were synthesised in fig. 2.7., 2.15. and 2.19. which are compiled in fig.2.20. In this figure, design management becomes a central function of the NPD process in a high tech environment and the advantages it can bring as well as the managerial and organisational changes that it supposes are presented.

First, design management enables the organisation to build a consistent corporate identity. But this requires the involvement of top management concerning different issues. In fact, top management



is responsible for initiating the implementation of a design-oriented culture and for providing adequate resources. It is also responsible for favouring the adequacy between the design and business objectives, which is often perceived as being hardly compatible. Moreover, an efficient information system is also needed to support the design strategy with updated market and environment-related data.

At the operational level, managers from the different departments involved in the NPD process must favour cross-functional collaborations and informality in order to reduce sources of disharmony. These managers must also co-operate in design management in order to favour its development throughout the organisation.

At the NPD stage, design will favour cross-functional exchanges thanks to visual aids and collaborative as well as informal methods. The existence of an independent design function is the best way to create a neutral interface between R&D, marketing and production. During NPD, design for manufacturability (DFM), design for assembly (DFA) and commonality will enable the production department to be involved in the early development activities. By working together at the concept-testing stage, marketing, R&D and production will reduce iterations (and, thus, time-to-market) and technological as well as technical uncertainty or risk. Moreover, the integration of the end-users will also lead to a reduction of market uncertainty. The use of visualisation tools, managed by the design team, is essential at that stage.

At the product level, design management will enable the firm to emphasise its corporate identity through appropriate product features. The role of the marketing department is also decisive to develop a mix which is coherent with the corporate values to be enhanced. Moreover, efficient product design will also value the inputs incorporated in the final product – e.g. technology, quality, etc. -.

At the launch stage, design must enable the organisation to differentiate its products from the competitors since corporate identity will be made visible. As previously explained, the NPD process, if efficiently managed, will eventually lead to a reduction of the time-to-market as well as of the level of risk taken.

Eventually, at the customers' level, efficient design management enables the organisation to launch products that are better adapted to market requirements. Moreover, factors such as better user-friendliness reduce the reluctance to adopt highly innovative products.

Throughout the whole process, the organisation is fed with customer-related information provided by both the design and the marketing functions. This contributes to reduce uncertainty.

This synthesis is decisive in the methodological process of the present piece of research since, according to the soft systems methodology, it will then be compared to the so-called "real world situation" – i.e. the diagnosis made on the basis of primary data collection - so as to determine the necessary actions to be implemented (Checkland and Scholes, 1990).

The methodological approach implemented throughout the research process will be detailed in the next chapter.



Fig. 2.20. – Synthesis of the key-factors derived from the literature review

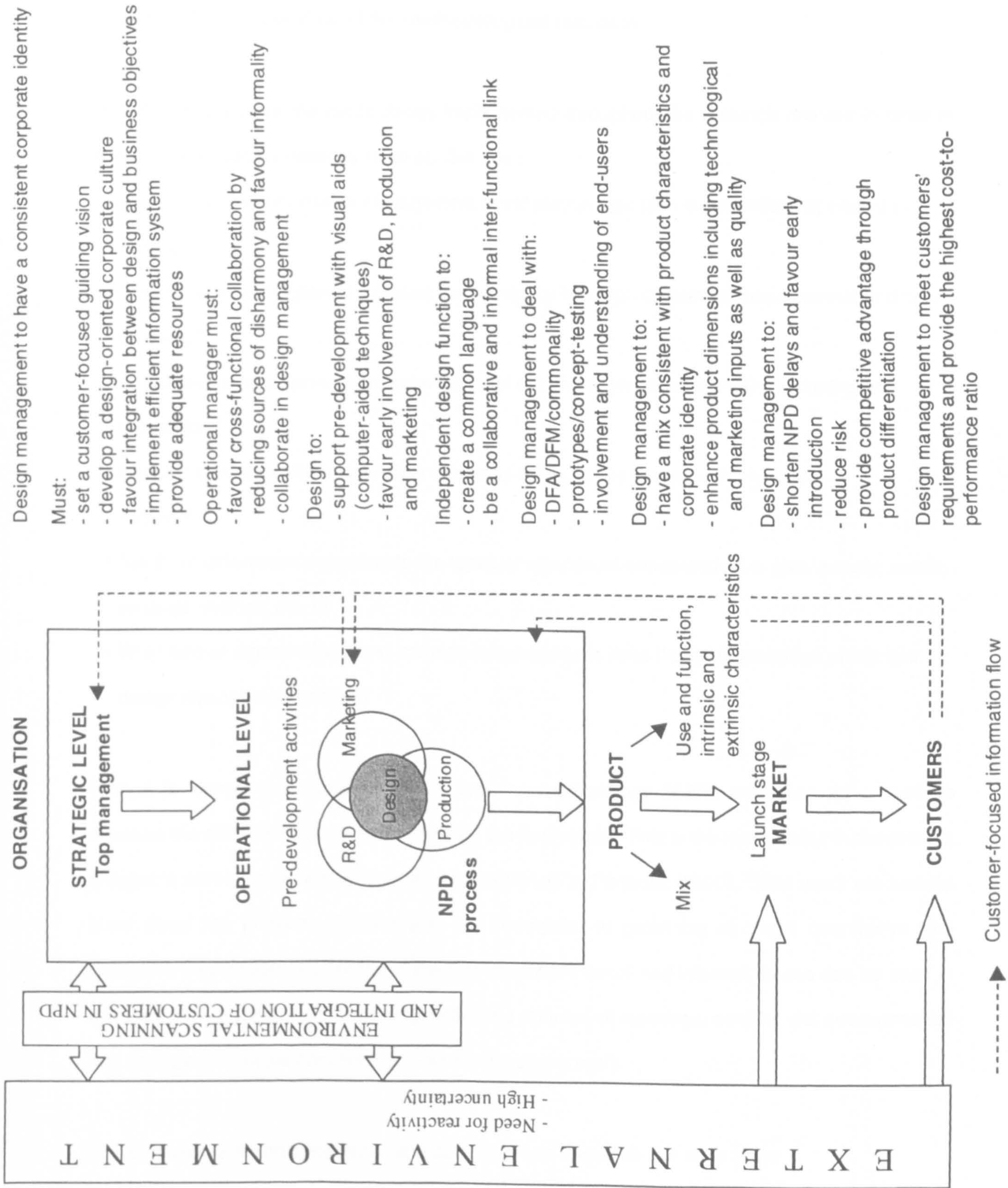



## **CHAPTER 3: METHODOLOGY AND SSM**

### **3.1. Introduction: overview of the methodological rationale**

This chapter presents the methodology implemented throughout the research process in order to answer the research questions listed pp. 3-4 , i.e.:

- What is the role that design management could play in high tech organisations operating in France?
- Could design management increase the adequacy between customers' requirements and new products?
- Could design management increase the level of integration between R&D, marketing and production?
- Could it, consequently, improve the efficiency of the NPD process in the high tech sectors?
- Are there differences according to the types of companies concerned – i.e. size, activity, sector, strategic choices, etc. -?
- What kind of organisational and managerial adaptations does the implementation of efficient design management require?

First, it is important to stress that soft systems methodology (SSM) was used as a basis to structure the different findings and to develop the final model. This is the reason why, in the present chapter, a section is dedicated to SSM. As mentioned by Ragsdell (2000), "SSM users are keen to learn about the problem situation and are committed to gathering as much quantitative and qualitative information as possible in the first instance. Formal and informal means can be used in this process – interviewing, observing, collecting minutes of meetings, sending out questionnaires and engaging in casual conversations could also play a role".

In accordance with this statement, data collection was based on five main steps:

- a literature review;
- a one-month placement in a high tech organisation;
- a first exploratory quantitative stage to make a diagnosis of NPD processes in the high tech



organisations operating in France;

- a second quantitative stage focusing on specific issues identified in the previous stages;
- a final qualitative stage to collect managers' suggestions about the model.

More precisely, the literature review enabled the researcher to gain an overview of existing research in the fields of NPD, high tech environment and design management, both at the international and at the French level. As concerns the one-month placement at Wandel and Goltermann, it was a good way of being totally immersed in the high tech business environment and to have a practical vision of the central issues – i.e. the complexity of the NPD process, the impact of quality procedures, the nature of inter-functional relationships, the integration of end-users' requirements, etc. -. These observations were integrated in the first exploratory survey which resulted in a diagnosis of the situation and also provide more precise issues concerning NPD processes in high tech organisations. These issues were analysed in the following quantitative stage which, again, enabled the researcher to narrow the spectrum of research by focusing on the nature of trans-functional relationships, the role of the information system and the impact of marketing and, eventually, on the vision that managers have of design management in the context of high tech NPD. The data collected throughout the previously described research stages provided answers to the research questions and fed the final model, the objective of which is to synthesise the actions to be taken so as to implement design management as an integrating function in the high tech companies operating in France, in accordance with the research problem. In the last stage, the interviews that were conducted with five managers were an important step to confront the final model with the business environment and to make sure that the recommendations were practically feasible and adapted to the high tech sector. These steps are detailed in the next sections.

Moreover, it is necessary to stress that in the course of the research, the author also attended several academic and professional conferences which were opportunities to exchange both with other researchers and with managers.

The new contribution to knowledge consists in a model showing the actions to be implemented so as to emphasise design as an integrative function in the NPD processes of the high tech firms operating in France.

## **3.2. Methodology**

### **3.2.1. The literature review**

The literature review facilitated the acquisition of knowledge about existing research in the fields of:

- NPD;
- high tech management and marketing;
- design management.

At the beginning of the research process, books relating to the above-listed fields were consulted. It enabled the researcher to gain knowledge about the main issues and principles relating to the research questions. At first, most of the literature that was consulted was international and, more precisely, predominantly Anglo-Saxon since both researchers and managers from these regions appeared to be more familiar with the design management questions. This stage was subsequently completed with literature published by French researchers in order to gain more knowledge about the specific issues raised by design management within the French environment. These first steps were completed by the collection of articles from many different research reviews such as The Design Management Journal, The Harvard Business Review, The Journal of Marketing, The Industrial Marketing Management Journal, Gestion 2000, etc. Articles were selected on the basis of references provided by previous researchers. In order to have an extensive view of existing research, data bases such as Delphes, ABI Inform, Emerald Library on line were consulted. Proceedings of different international conferences were also reviewed with special attention to the Sixth International Forum on Design Management held in Paris (France) in June 1994, in which several French researchers participated. At the end of the research process, the literature review was updated with new articles so as to be aware of the most recent pieces of research.

This first stage was critical to gain knowledge about existing literature and models relating to NPD and more precisely to the management of R&D, marketing and production interfaces in high tech sectors as well as about design management. This information was then used as a basis for



comparison between the methods that should be implemented to develop efficient interfaces and what is actually done, in situ, among the high tech companies operating in France.

### **3.2.2. Placement in a high tech organisation**

At the very beginning of the research process, together with the literature review, a one month placement at Wandel & Goltermann, a company developing Integrated Services Digital Networks (ISDN) testers, enabled the researcher to gain knowledge about NPD in an organisation developing high tech products. The objective at that point was to be confronted to a real-world situation and to lay the foundations of the questionnaire to be used for the exploratory stage – i.e. inductive approach -. In fact, as stressed by Woolley (1999), “a single case study may only contribute to a generic hypothesis”, however, “the issues raised may be relevant to other contexts in which industrial design practice is introduced at a fundamental level within technology-based companies”. Moreover, according to Woolley (1999), and taking the example of the Teaching Company Scheme (TCS), there is a need for research applicable to real-world business problems. Thus, the study that was conducted at Wandel & Goltermann was a way of gaining more knowledge about real-world practices in terms of NPD processes.

As regards the methodology used to gain information, internal documents – e.g. internal facts and figures, product development templates, quality procedures, sales guides, etc. - were collected and regular interviews were conducted with the marketing manager, the managing director, as well as with product engineers so as to gain insight into the managerial and organisational factors relating to NPD in the company. This resulted in a diagnosis of the company’s situation as regards NPD which enabled the researcher to identify key-factors impacting on the management of the NPD process.

At the end of the placement, a presentation of these observations was made to the general director as well as to the marketing manager of the company.

### **3.2.3. Links between literature review, placement and following stages**

The most critical issues that appeared in the literature review and during the placement at Wandel & Goltermann related to:

- overall management of NPD;
- organisational issues;
- relationships between R&D, marketing, production;
- quality certification and NPD;
- the information system;
- customer integration in NPD;
- the role of design management.

These aspects were integrated in the questionnaire used in the next exploratory stage, which is presented in the next section.

#### **3.2.4. First quantitative stage**

The objective of a quantitative survey is to count and compare so as to make a diagnosis of a given situation (Giannelloni and Vernet, 1994). This was the aim of the two quantitative stages implemented during the research process.

This first quantitative and exploratory survey was sent in 1998 to all the companies identified as belonging to high tech and medium/high tech sectors in France – i.e. 3006 firms -. These sectors were chosen according to the classification of the OECD – see table 2.4. section 2.4.2.5 - that has divided companies between different categories according to their levels of technological inputs: high tech, medium-high, medium-low, low tech. Since the study was focusing on companies with heavy technological activities, the first two categories – i.e. high tech and medium-high tech - were kept as they are both above average concerning technological inputs. The French Ministry of Industry was contacted to provide a list of the corresponding French sectors of activities, classified according to the so-called APE codes. The below-listed sectors are the ones that belong to the high and medium/high fields of activity:

- development and manufacturing of machine-tools and equipment;
- development and manufacturing of office machines and computer equipment;
- development and manufacturing of electrical machines and appliances;
- development and manufacturing of radio, television and communication equipment;
- development and manufacturing of medical, precision, optical and watch-making instruments;
- automotive industry.



The questionnaire, shown in appendix 2 and detailed in chapter 5, was designed according to the issues that emerged from both the literature review and the observations made at Wandel & Goltermann. The questionnaire was composed of the following sections:

- identity of respondent and data about the firm;
- information about R&D;
- information about organisational factors;
- information about marketing;
- information about NPD;
- information about product success.

The objective at that stage was to be able to make a diagnosis of the NPD processes of the high tech companies operating in France. In fact, little recent literature existed as regards this precise issue. And, as stated by Potter (1992), "postal surveys can be used to target companies for in-depth study, while producing useful information based on a large number of firms". Accumulating information so as to gain a deeper knowledge of the situation was exactly the objective of this postal survey.

107 exploitable answers were returned. They provided data about product development management, interfaces between R&D, marketing and production. The major critical issues that emerged were integrated in the design of the next questionnaire to gain deeper insight of the situation.

### **3.2.5. Second quantitative stage**

A second quantitative survey, the objective of which was to focus on inter-functional relationships as well as on the perception companies had of the role of design management, was launched between May and October 2000. 800 companies, out of the 3006 previously mentioned, were randomly selected from the list provided by the INSEE used for the first exploratory stage. The questionnaire was faxed to them and was systematically followed by two reminders. 148 exploitable questionnaires were returned – confidence: 90% and  $e=3\%$  -.

The questionnaire, shown in appendix 3 and detailed in chapter 5, included the following four main sections:

- general information about the company;

- information relating to project management and to the relationships between R&D, marketing and production;
- information relating to marketing management and the marketing information system;
- information relating to design.

### **3.2.6. Links between first and second quantitative stages**

The first survey was for the purpose of gaining new knowledge about product development in the high tech companies operating in France. Most of the data collected was not available in the existing literature. Among other things, the survey revealed that:

- forms of collaboration in new product development depend on the size of organisations;
- design is not perceived as important in new product success;
- marketing information system is not formally managed and is granted little consideration;
- cross-functional exchanges are mostly formal.

Thus, the first exploratory survey produced a diagnosis of the present situation and identified the critical factors mentioned above. The second quantitative survey, focusing on design management, and sent to high tech companies, lead to more accurate knowledge about NPD in the high tech companies operating in France, and more precisely about the way the interfaces between R&D, marketing and production are managed and about the place granted to design – i.e. the 'real world' situation (Checkland and Scholes, 1990) -. The objective being to depict the situation, descriptive statistical analysis was used for both quantitative stages.

The data collected in the quantitative stages enabled the researcher to design a model, based on soft systems methodology. This model was then submitted to a sample of five managers operating in the field of high technology so as to check its relevancy in the 'real world' and to gain in depth knowledge of the factors to be taken into account to ensure implementation.

### **3.2.7. Qualitative stage**

"Design management research (...) involves a mixture of quantitative and qualitative data of varying complexity" (Potter, 1992). "Theory which is not tested out in practice is sterile. Equally, practice which is not reflective about the ideas upon which it is based will abandon the chance to



learn its way steadily to better ways of taking action” (Checkland and Scholes, 1990) Consequently, a qualitative stage took place in April 2001, in order to confront the model which emerged from the literature review and the two quantitative stages with ‘the real world’ situation.

Five managers from high tech fields were contacted by the researcher to give their opinions about the developed model. These managers were either from organisations with a strong design orientation – Philips semi-conductors, Hercules Technologies, e-generis – or managers with reduced design orientation – Laboratoire Européen d’ADSL and Acterna (formerly Wandel & Goltermann) – and likely to initiate or to develop their design orientation. In fact, these companies were known by the researcher, which enabled her to build a sample mixing strongly and weakly design-oriented companies.

The model, the relevant explanation and the questions to be answered were faxed to the companies and followed by face-to-face or phone semi-structured interviews since the objective was to collect respondents’ comments on the model (Giannelloni and Vernet, 1995). The questionnaire (see appendix 4) was composed of an introductory section relating to the company – e.g. number of employees, activity, etc. -, followed by nine open-ended questions. The first question was about the vision that managers have of the role of design, the objective being to confirm whether the firm was strongly design-oriented or not. In the following seven questions, respondents were asked to comments on the components of the model. In the last section, respondents could add any necessary comments.

The comments and remarks collected in the qualitative stage were included in the section dedicated to the presentation of the final model, either to illustrate the researcher’s explanation or to emphasise practical issues.

### **3.2.8. Overview of methodological process**

On the basis of the SSM approach, the building of the model was done by following the below-listed steps:

- the situation to be reached was determined according to the recommendations issued from the literature review and relating to the best practices in terms of NPD and design management.

The answers given by the respondents as regards the points to be improved and the state they wanted to achieve – e.g. increased knowledge of customers' requirements - were also taken into account;

- the diagnosis of the current situation of NPD and design management in the high tech firms operating in France was done on the basis of the observations made at Wandel & Goltermann and during the two quantitative stages;
- the situation to be reached and the 'real world' situation were compared so as to determine the actions to be implemented to fill the gap.

Components of the final model are based on a comparison made between existing practices – i.e. data issued from the quantitative stages - and on existing research about best practices. Qualitative interviews enabled the researcher to relate the model to the business world so as to be as practical and realistic as possible. The objective was to make the final model more accurate and to integrate the data derived from secondary, primary, quantitative and qualitative sources.

The methodological process implemented for the present piece of research is illustrated in fig. 3.1.

**Fig. 3.1. - Methodological process**

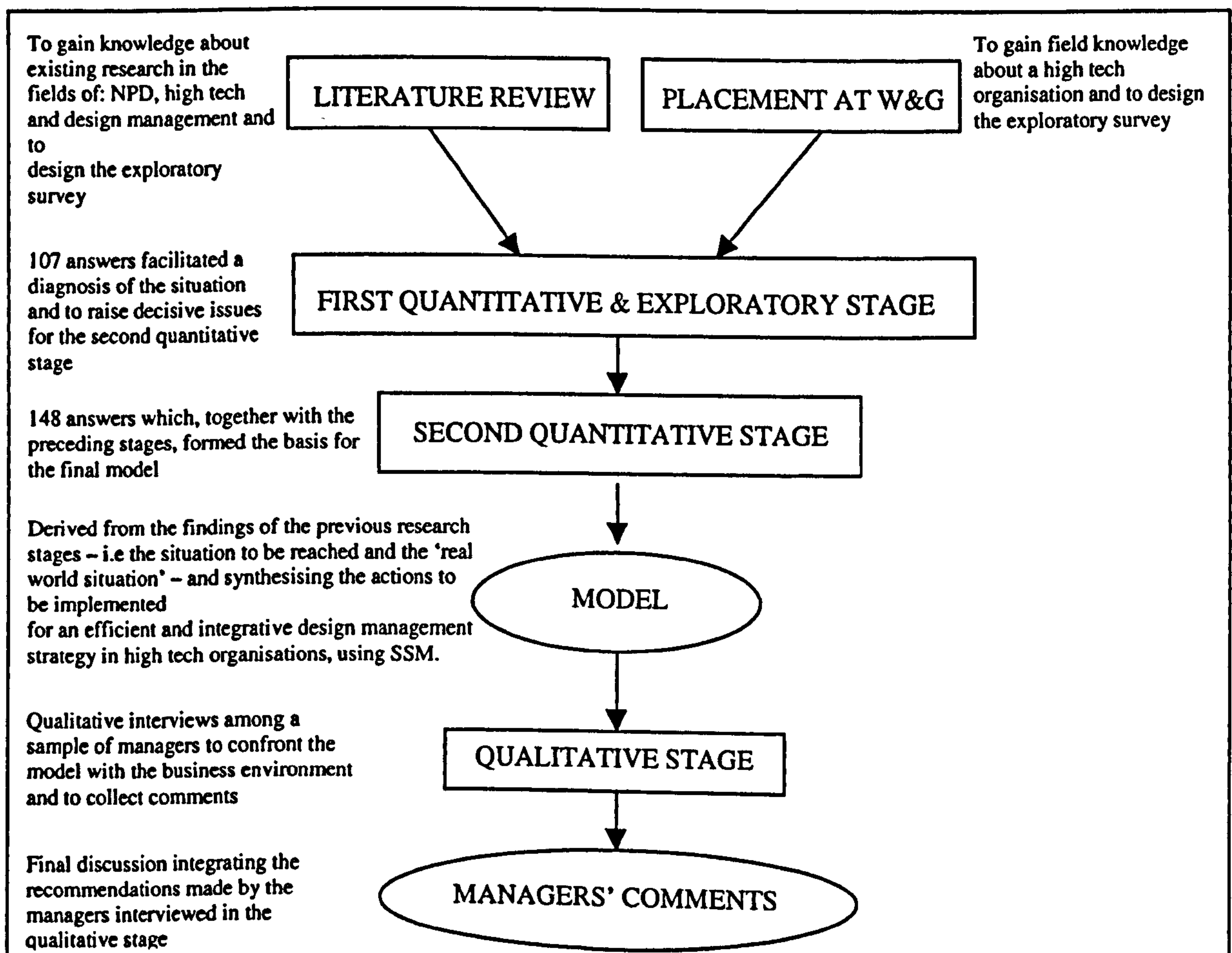



As mentioned earlier, the final model was developed on the basis of the soft systems methodology (SSM). The next section provides an overview of the principles guiding such methodology.

### **3.3. Soft systems methodology**

#### **3.3.1. The philosophy of SSM**

SSM was initiated by Peter Checkland at Lancaster University, Department of Systems and Information Management, and has been developed over the last 25 years. SSM was elaborated through action research and resulted from much consulting work (Platt and Warwick, 1995).

As stressed by Bentley (1993), "there is growing concern about the interactions between people" and "the focus changes from 'hard' systems to 'soft' systems". In SSM, people are viewed as active subjects (Pratt and Warwick, 1995). "Soft systems methodology helps managers, of all kinds and at all levels, to cope with their tasks. It is an organised way of tackling messy situations in the real world. It is based on system thinking, which enables it to be highly defined and described, but is flexible in use and broad in scope" (Checkland and Scholes, 1990). As outlined by Bentley (1993) and Platt and Warwick (1995), the main purpose of SSM is to find good ways of handling a situation, taking into account the diversity of opinions of the people involved, rather than simply providing the best recipe on the assumption that it will be widely applicable throughout the entire organisation. SSM aims to bring structure and understanding to unstructured situations.

According to Vakola and Rezgui (2000), "it is extremely difficult, if not impossible, to produce standard 'recipes' of success applicable to every business sector". Planning, implementation and monitoring are common bases but each sector has its proper characteristics and each organisation has its own culture. In fact, the problem raised by most methodologies is that they do not go further than the implementation stage, whereas they should also integrate continuous evaluation and improvement so as to permanently adapt to the features of today's changing environment. This is also outlined by Checkland and Scholes (1990) for whom the importance of human factors should be taken into account when working on organisational processes, so as to develop appropriate solutions. SSM is, thus, applicable to social and managerial issues. As opposed to scientific knowledge which is based on duplicable experiments, social and managerial issues are mostly based on 'experience-based knowledge'.

**Fig. 3.2. - The experience-action cycle**

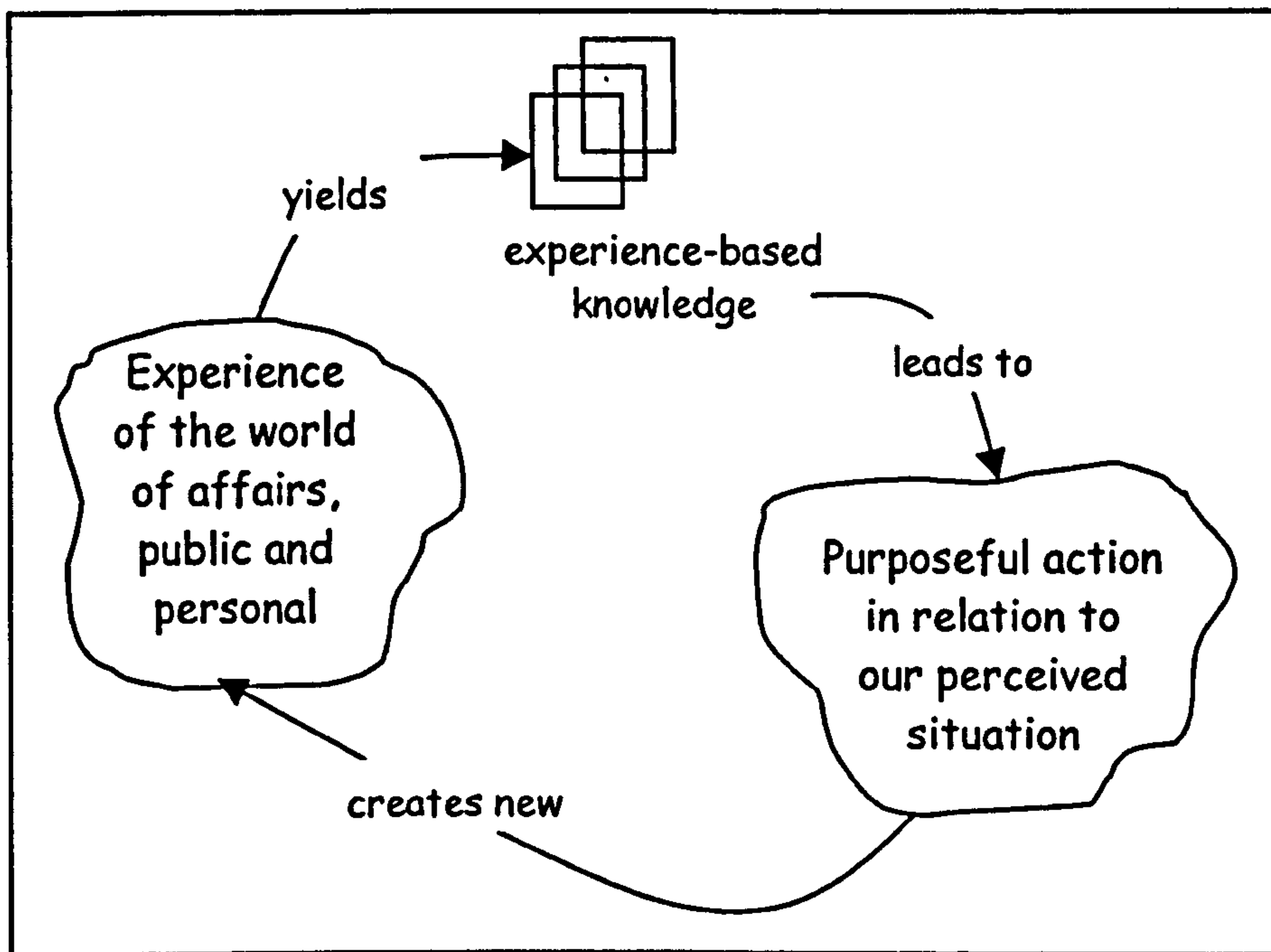

Source: Checkland and Scholes (1990)

Fig. 3.2. illustrates the relationship that exists between experience and action in managerial fields. The language that will enable the articulation of the operation of the above cycle can be defined as systems thinking and SSM is "a methodology for operating the endless cycle from experience to purposeful action". A system is defined as "a set of elements mutually related such that the set constitutes a whole having properties as an entity" (Checkland and Scholes, 1990).

### 3.3.2. The steps guiding SSM

Fig. 3.3. presents the basic shape of SSM which is, then, more detailed in fig. 3.4.

**Fig. 3.3. - The basic shape of SSM**

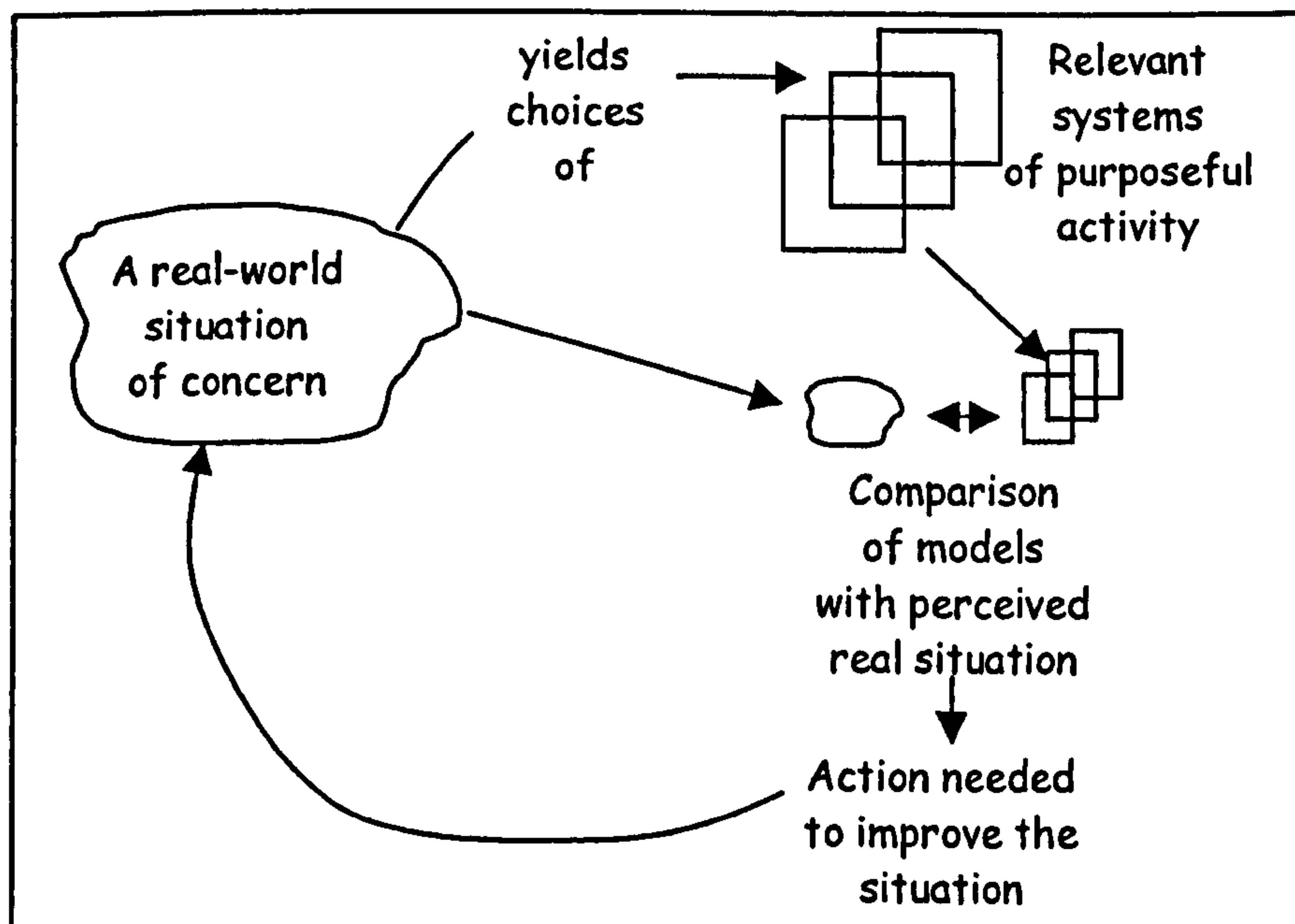

Checkland and Scholes, 1990



The main steps of the SSM process are the following (Checkland and Scholes, 1990; Pratt and Warwick, 1995):

- a situation raises concern and the problem situation unstructured is identified;
- the problem situation is expressed;
- root definitions of relevant systems are made;
- relevant human activity systems (HAS) – i.e. models of systems to carry out purposeful activity – are selected and modelled;
- the model is used to question the real-world situation in a comparison phase;
- the debate initiated by the comparison to define purposeful action(s) is used to improve the original problem situation and to define feasible, desirable changes;
- actions are taken in accordance with the defined changes. Eventually, taking the action would itself change the situation, so that the whole cycle can begin again.

Thus, the conventional process that guides SSM is based on seven stages. These stages are divided between what concerns the real world and system thinking about the real world – i.e. the filter through which individuals perceive the world -. This process is illustrated in fig. 3.4.

**Fig. 3.4. - The conventional seven-stage model of SSM**

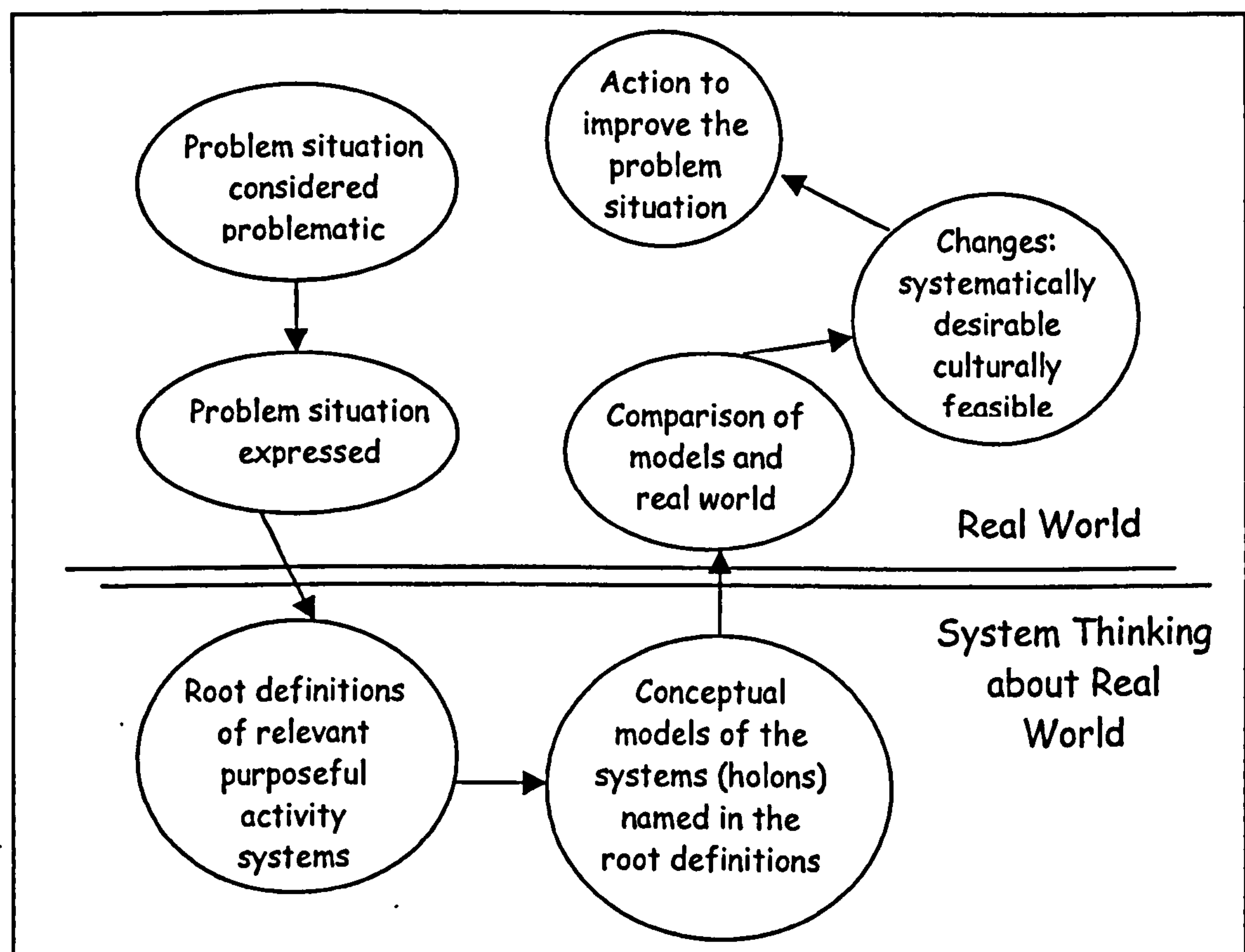

Source: Checkland and Scholes (1990)

In fig. 3.4., root definition is a crucial step in expressing the identified problem situation.

### 3.3.3. Root definition and CATWOE mnemonic

“A root definition expresses the core purpose of purposeful activity system” (Checkland and Scholes, 1990). The CATWOE mnemonic – see table 3.1. - will help formulating root definition and is used as a checklist to make sure that the root definition is complete. Each root definition will then lead to a conceptual model (Pratt and Warwick, 1995).

**Table 3.1. - The CATWOE mnemonic**

<b>C</b>	<b>'customers'</b>	<b>:</b>	<b>the victims or beneficiaries of T</b>
<b>A</b>	<b>'actors'</b>	<b>:</b>	<b>those who would do T</b>
<b>T</b>	<b>'transformation'</b>	<b>:</b>	<b>the conversion of input to output process'</b>
<b>W</b>	<b>'Weltanschauung'</b>	<b>:</b>	<b>the worldview which makes this T meaningful in context</b>
<b>O</b>	<b>'owner(s)'</b>	<b>:</b>	<b>those who could stop T</b>
<b>E</b>	<b>'environmental constraints'</b>	<b>:</b>	<b>elements outside the system which it takes as given</b>

Source: Checkland and Scholes (1990)

### 3.3.4. Conceptual model

The conceptual model is built on the basis of root definition. As explained by Pratt and Warwick (1995), “the conceptual model identifies the minimum necessary activities for the HAS. In addition, it represents the relationships between the activities”. The conceptual model must encompass all the elements of the CATWOE mnemonic and must identify the activities to be included in the previously identified HAS (Holland, 1993). The following step is to compare the model with the real world to identify possible changes. Eventually, recommendations for change are implemented.

However, another important element of the SSM approach must be outlined. Since SSM aims at identifying a problem situation and eventually suggesting the actions to be implemented to solve



this problem, it will be decisive to clearly express and visualise the current situation. At this stage, rich pictures will be used. The principles of rich pictures are presented in the next section.

### **3.3.5. Rich pictures**

A transformation process will turn “input” into “output” – i.e. a given entity into that entity in a transformed state – (Checkland and Scholes, 1990). This is what Ragsdell (2000) calls the “before” and “after”, since “the intention of any organisational change, one would expect, is to move the organisation from its current state to a more desirable, improved state”. This supposes to make a previous diagnosis of the situation so as to understand its features and, more importantly, the “philosophy” behind it (Ragshell, 2000).

‘Rich pictures’ will help in formulating the input and visualising both present and desired situations. (Ragsdell, 2000; Checkland and Scholes, 1990). They will provide another means of understanding and communicating about given situations (Bronte-Stewart, 1999). As explained by Pratt and Warwick (1995), the main purpose is to represent graphically all the relevant information and relationships. In fact, as stated by Bronte-Stewart (1999), rich pictures will enable “to consider and convey perceptions of softer aspects in a situation such as attitudes, problems, roles, conflicts, harmony, tensions, influences, fears, wants, organisational culture and politics”. It will be an effective manner to represent the atmosphere of a situation, mostly in a qualitative way. As stressed by Ragsdell (2000), “developing ‘rich pictures’ is a craft rather than a science”. However, as stressed by McDermid (1990), “there are no rules as such for the format that a rich picture must conform to”. It can be done by hand or with a software, even though using a pre-defined set of symbols is likely to somehow restrict creativeness (Avison et al., 1992).

As stressed in the introductory section, the SSM process generally starts with wide data collection so as to learn more about the situation to be studied (Ragsdell, 2000). The following stage relates to the use of ‘rich pictures’ to represent the situation. The comparison between the real world situation and the desired objective will finally lead to recommendations that are “desirable and culturally feasible” (Checkland and Scholes, 1990).

### 3.3.6. Application of SSM to the research problem

As previously explained, the SSM approach enables the researcher to generate as many questions as possible relating to a given situation. On the basis of the literature review, it is already possible to provide a first version of the CATWOE mnemonic so as to identify the different actors playing a role in the NPD process of high tech organisations. The CATWOE mnemonic, will then lead to the drawing of a rich picture representing the different factors to be taken into account in the research process, and which will expand the understanding of the problem situation. This will facilitate the expression of the root definition in order to articulate the core purpose of the defined purposeful activity system.

#### 3.3.6.1. CATWOE

**Table 3.2. - CATWOE mnemonic applied to research problem**

<b>C</b>	<b>'Customers'</b>	Victims or beneficiaries of T	The organisation
<b>A</b>	<b>'Actors'</b>	Those who would do T	Top management
<b>T</b>	<b>'Transformation process'</b>	The conversion of input to output	Implementation of design management in high tech companies
<b>W</b>	<b>'Weltanschauung'</b>	The worldview which makes T meaningful in context	Design management can favour exchanges and enhance market-orientation
<b>O</b>	<b>'Owner(s)'</b>	Those who could stop T	Top management, investors, people involved in NPD
<b>E</b>	<b>'Environmental constraints'</b>	Elements outside the system which it takes as given	Reactivity Uncertainty

The organisation is seen as the 'customer' since it is the entity that will benefit from the implementation of the 'transformation process'. Top management is the main actor of such a process. It is responsible for the initiation and implementation of a design-oriented strategy in the organisation. As stressed in the literature review, design management enables managers to develop cross-functional exchanges and to enhance market orientation. This is the central principle underpinning the transformation process. The 'owners' are top management and the investors who can decide not to implement the transformation process, and the people involved in NPD who can



slow down the process by being, for instance, resistant to change. Eventually, the major 'environmental constraints' that emerged in the literature review concerned the increasing need for reactivity and the heavy uncertainty pressures.

### **3.3.6.2. Rich picture**

The rich picture presented in fig. 3.5. synthesises the situation relating to NPD in high tech organisations. This rich picture was first drawn by hand and then on a computer for presentation matters. Thus, using a software was not detrimental to creativity.

The literature review identified the following factors as affecting NPD in a high tech environment:

- **THE UNCONTROLLABLE FACTORS** – external to the system -, the pressure of which will permanently affect the organisation and generate uncertainty;
- **MANAGEMENT** – internal to the system -, who must set the corporate guiding vision and who will influence the entire organisation and **THE INVESTORS** – external to the system -, who want the firm to be as profitable as possible;
- **THE POOL OF EXPERTISE** – i.e. the employees – which will be the main resource of the company and that will encompass different functions interacting between one another throughout the NPD process;
- **THE MARKETPLACE**, which will be the interface between offers and demand and where the company will have to challenge its competitors;
- **THE CUSTOMERS**, who must be satisfied so as to guarantee the firm's survival.

Among these factors, there are actors with their own vision of the situation. Their thoughts are expressed in balloons. Then, symbols are used to represent the nature of certain components of the problem situation – e.g. dynamite highlights a dangerous factor and the clock the importance of the time factor -, the assumption being that symbols reduce the bias that language creates.

When assembling all the pictorial representations, the rich picture helps to visualise the actual situation as well as both the factors that impact on the system and the relationships that link the different actors. Eventually, the rich picture emphasises the factors and questions that will have to be taken into account in order to analyse the situation. In the present piece of research, it was a helpful step to structure the information gathered in the literature review and to build the exploratory survey, as shown in fig. 3.6.



Fig. 3.5. - Rich picture

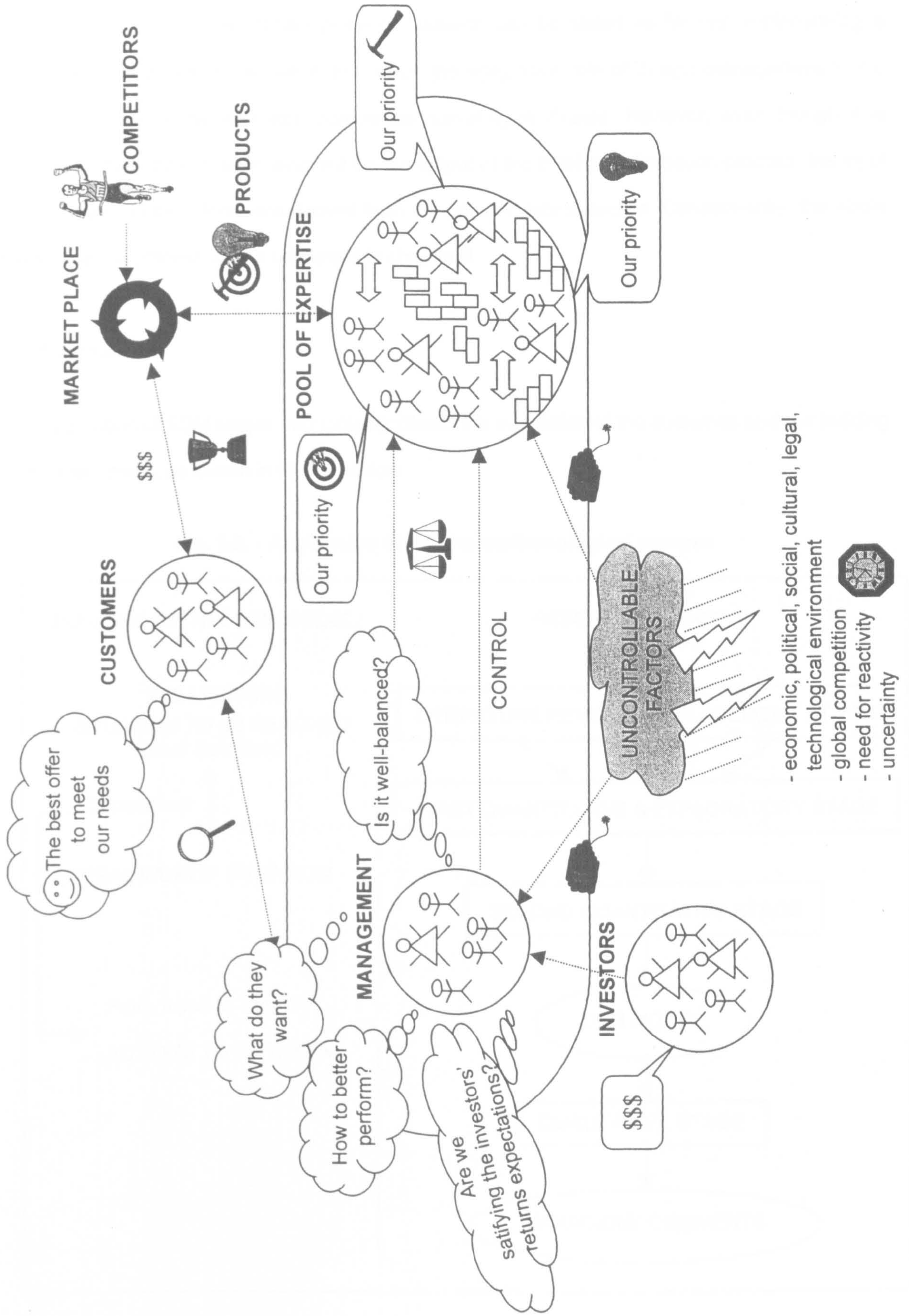

- economic, political, social, cultural, legal, technological environment
- global competition
- need for reactivity
- uncertainty



### 3.3.6.3. Root definition

The root definition for the present piece of research can be stated as follows: implementing a corporate strategy and organisation that value the integrative role of design management in the NPD processes of the high tech companies operating in France. However, even though it is possible at that stage to state what will be the output of the SSM transformation process, the input will be based on the information derived from the primary data collection. Consequently, the whole transformation process will be presented in chapter 6.

### 3.4. Conclusions

The application of SSM stages and tools facilitated the evaluation of the outcomes and the building of the final model, as shown in fig. 3.6. below:

Fig. 3.6. - Application of SSM to methodological process

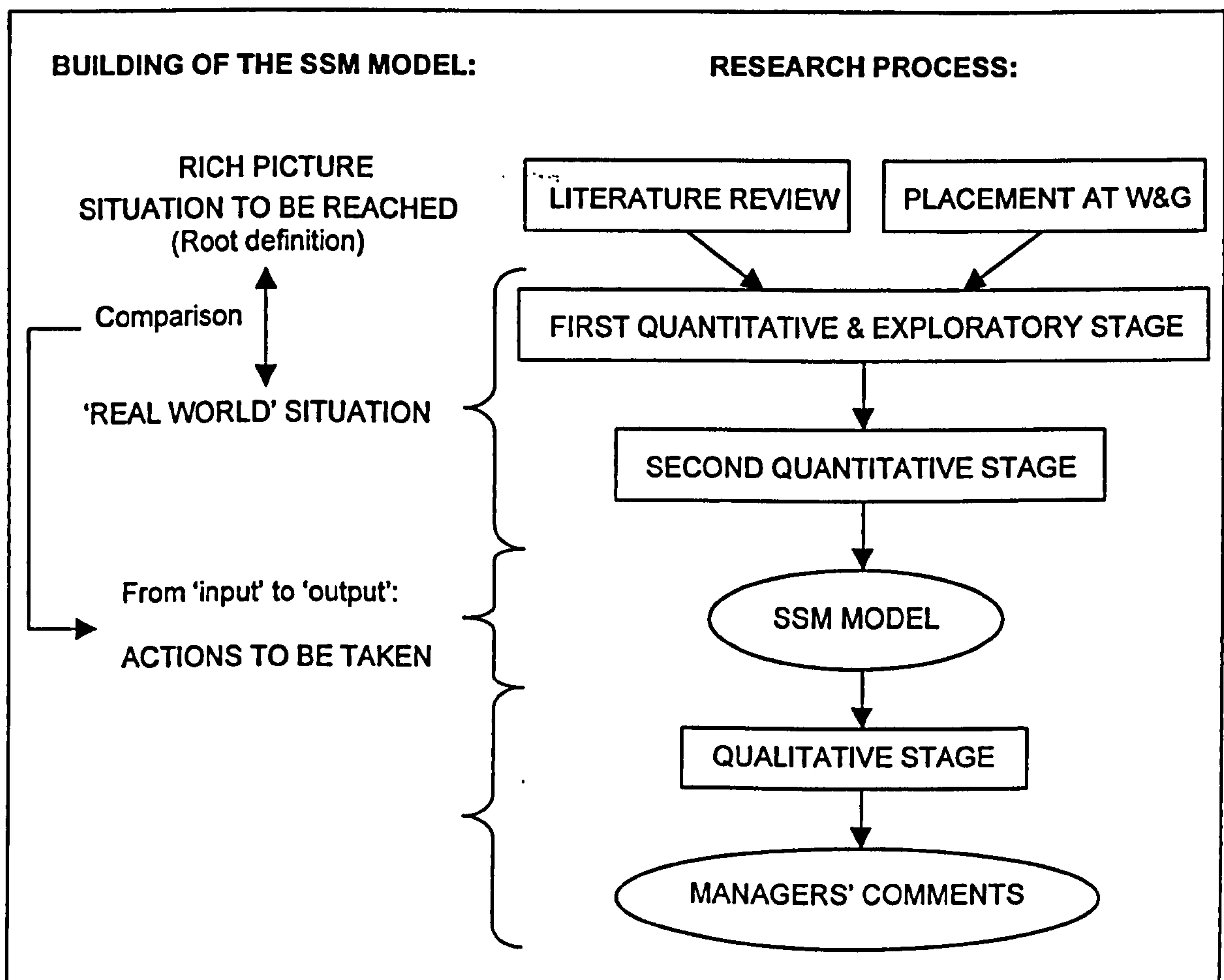

The next chapter will present the results of the one month placement at Wandel and Goltermann.

## **CHAPTER 4: PRODUCT DEVELOPMENT AT WANDEL & GOLTERMANN FRANCE**

### **4.1. Introduction**

This chapter will present the observations issued from a one-month placement that took place in 1998 in a telecommunication company. The aim of this placement was to gain deeper practical knowledge of NPD in a high tech company so as to adopt an inductive research approach in coherence with the high tech environment and its operational constraints. The objective at this stage was to confront the information gathered through literature review with the processes applied in a high tech organisation so as to be more aware of the processes, exchanges, constraints, etc. that impact on NPD, in situ.

First, data concerning the company will be provided in order to better know about its organisation and environment. Then, the dissertation will focus on the NPD process and describe the procedures that are applied at WG<sup>1</sup>. Finally, the way NPD is actually managed in this given organisation will be compared with the information previously collected through literature review. This will lead to a diagnosis of WG relating to its NPD process. This will allow to evaluate and improve the list of factors issued from the literature review. It will also enable to lay the foundations of the questionnaire that will be used for the exploratory stage.

### **4.2. Presentation of the group and of the company<sup>2</sup>**

#### **4.2.1. The group**

The WG group is German and employs about 1,600 people and comprises 5 independently operating divisions (four in Europe and one in the USA), 29 independent sales companies and about 65 sales representatives all over the world, as shown in fig. 4.1.

---

<sup>1</sup> These first two parts are based on the data and information provided by internal documents such as the Group's facts and figures, the quality manual, the managers' introduction file and the sales guide.

<sup>2</sup> Facts and figures relate to year 1997



**Fig. 4.1. - Structure of WG Group**

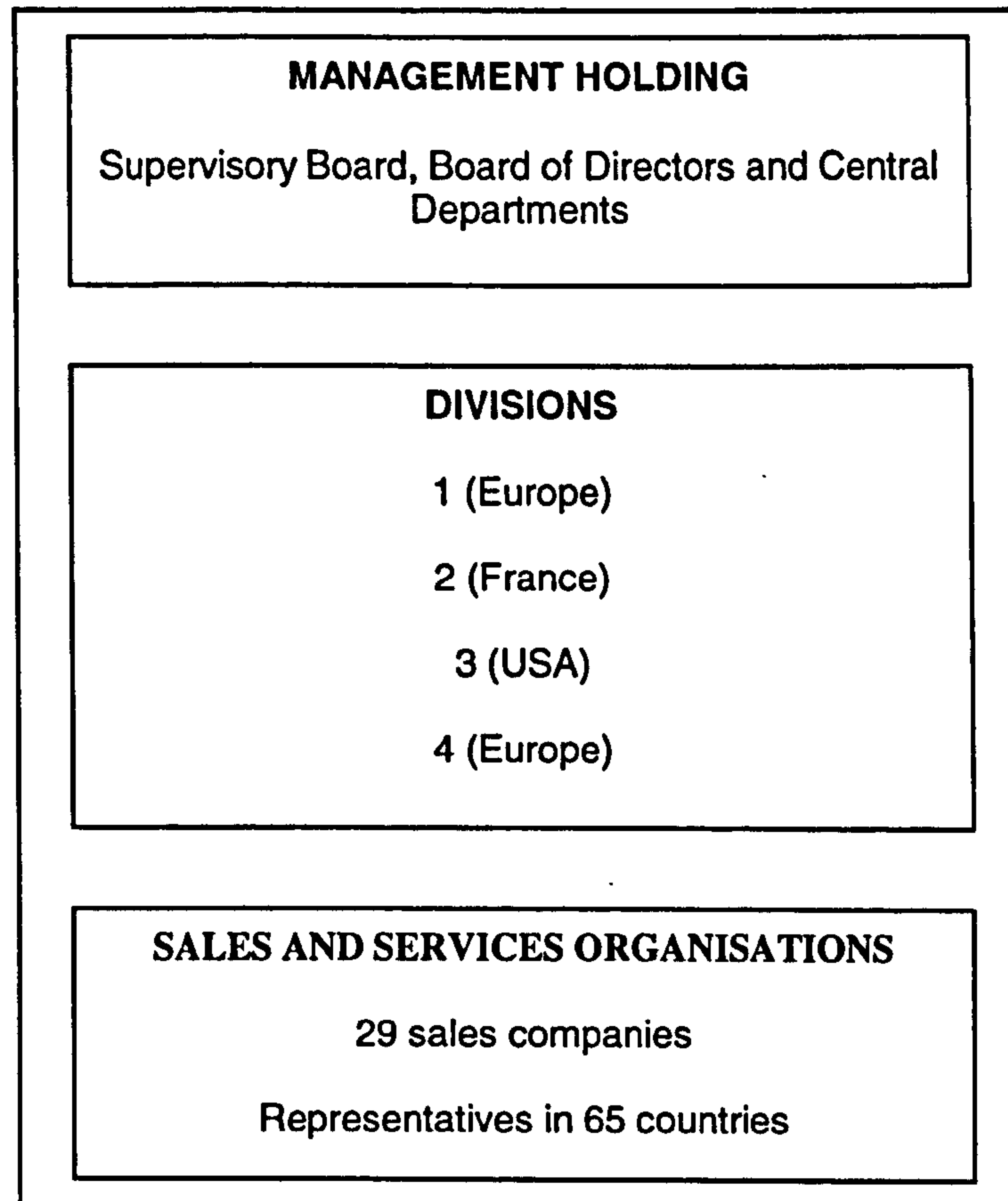

A management holding company co-ordinates and manages the group as a whole. It includes a supervisory board, as well as the management and corporate departments. The divisions operate within given market segments, which complement each other. Each division is fully responsible for product planning, development, marketing and manufacture of their own products. However, the divisions make common use of the world-wide sales organisation that belong to the group. Each sales company is responsible for providing optimised customer service in its own sales region. As well as direct sales activities, they also have responsibility for indirect market access and for all added value services, both pre-sales and after sales. This includes equipment servicing as well as training and project-related advice.

The mission statement for the group is the following: "To fulfil the high targets of our company vision, WG group will continue to be an independent, decentralised, and multi-national network of divisions. These will be combined with a strong, world-wide sales presence, provided by regionally managed local sales companies. By this means, we will serve each customer according to his/her unique geographical and cultural expectations".

## 4.2.2. French division

The end of state telecommunications monopolies, coupled with an increase in market competition has led to the rapid expansion of ISDN technology. Increasing demand for Internet services has provided an additional demand for ISDN. The French division develops and markets the measurement technology for this market segment. It was founded in 1990 and, in 1997, the division employed 40 people concentrating on the field of telecommunication, and more precisely ISDN. The same year, the French division obtained the ISO 9001 certification.

### 4.2.2.1. Activities

WG France key activities are:

- product definition including market analysis and technological monitoring;
- product design and development including hardware and software and mechanical aspects;
- manufacturing through subcontractors;
- product launch;
- sales support.

Products are distributed through the sales organisations (WG subsidiaries or agents).

### 4.2.2.2. Organisational structure

Fig. 4.2. - WG France organisational structure

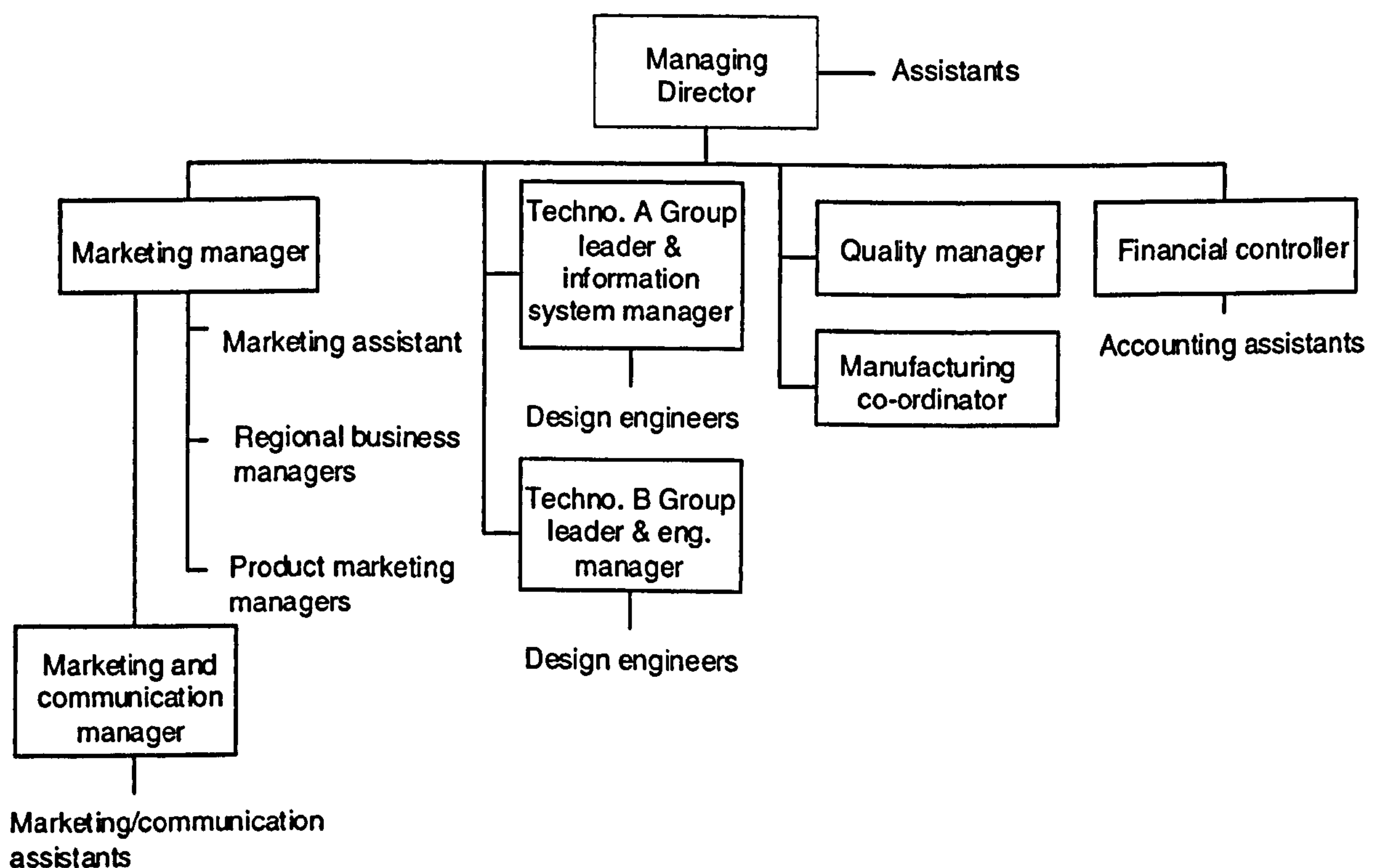



### **4.3. General philosophy as regards NPD**

The Quality Manual used at WG France states that “one key factor of success for a product is its availability on time and the proper co-ordination of the launch operations with the first deliveries, called “First Customer Shipment”. This can only be achieved through a structured project organisation and a plan for scheduling project tasks.”

This statement confirms that WG is highly conscious of the importance of efficiently managing the NPD process. This is mainly achieved through a set of formalised processes going from the predevelopment activities to the actual launch of the product on the marketplace.

#### **4.3.1. Documents relating to NPD at WG France**

Six main documents are used throughout the NPD process. The first two are major documents of reference that describe the global NPD process, whereas the last five mainly concern the marketing and development for a specific product:

- the quality manual;
- the guiding plan;
- the business case;
- the product requirement specifications (PRS);
- the project plan;
- the manager’s product introduction file (MPIF);
- the sales guide.

Each of the above-listed documents has a pre-determined structure that is presented in a ‘template’ version – i.e. a basic version of the document including all the elements that must be developed for each new product launch -. In order to better understand the formalisation of the NPD process at WG, the role and content of each of these documents will be detailed in the next sections.

##### **4.3.1.1. The quality manual**

It is a major document describing the company’s quality system and which is based on the stated policy and objectives as well as on the applicable ISO 9001 standards. The quality manual

concerns all the activities of the division linked with design, implementation, launching and support of the products.

#### **4.3.1.2. The guiding plan**

The guiding plan is either 'brief' or 'detailed': the brief guiding plan provides a general view of the product life – see fig. 4.3. - whereas the detailed guiding plan identifies separate sub-tasks and is used for setting up the project plan – see fig. 4.4. -.

#### **4.3.1.3. The business case**

It is issued for the first milestone review (called M0) and is intended for the managing director of the division. The business case must help the managing director to make decisions before the project is started. It provides a first view of the planning which is then definitely validated in the MPIF. The main sections of the business case are:

- market;
- customers;
- product;
- product benefits;
- competitors;
- objectives;
- launch plan.

#### **4.3.1.4. The product requirement specifications (PRS)**

This document, issued by the product marketing engineer during the development cycle and the specification phase, is used as an interface between the marketing department and the development team. It describes in detail the product external specifications and constraints and complements the preliminary product requirement specifications issued during the feasibility study and feasibility phase.



#### **4.3.1.5. The project plan**

It is established by the project leader during the feasibility stage of NPD and defines project organisation and schedule.

#### **4.3.1.6. The managers' product introduction file (MPIF)**

It is the first official document that commits to the launching of a new product. This document is meant to allow quick and systematic finding of necessary information as regards product launch, through a generic plan. The MPIF is issued by the product marketing engineer and is targeted at the board of management, the division managers as well as the sales organisation managers. Its main purpose is to identify and describe the market and to enable the people concerned to measure the objectives of a product so as to plan and organise the resources that the product launch will require – i.e. human, financial, etc. -.The MPIF is normally sent to the sales organisations six months before the first customer shipment (FCS), thus enabling the managers to implement the necessary training, advertising, etc. so as to support the product launch. One major objective of the MPIF is to motivate the sales organisations to sell the new product. However, the MPIF is not directly intended for sales engineers who will, instead, use the sales guide to organise the launching stage of a new product.

#### **4.3.1.7. The sales guide**

This document is issued by the product marketing engineer, three months before the FCS. It is intended for sales engineers and includes full information on product design and characteristics as well as the means for marketing it. It also includes information concerning competitors' products. The main objective of this guide is to motivate the sales teams and to provide them with all necessary information to sell the product in the most efficient way.

#### **4.3.2. Conclusions**

The different documents presented in the previous sections are all intended at carefully planning and monitoring product development and launch. However, even though they provide a detailed and

formalised structure to deal with NPD stages, they also lead to a heavy amount of information to be managed. The risk is that all these different forms eventually increase formalism and delays thus feeding vicious circle of long development cycles presented in section 2.2.6.1. (Smith and Reinersten, 1991).

In addition to these documents, different functions intervene in the NPD process and are presented in the next sections.

### **4.3.3. Main functions intervening during NPD**

#### **4.3.3.1. The managing director**

He/she is in charge of all the activities of the division and is responsible for the launch process of new products. He/she makes decisions about whether milestone reviews are passed or not and keeps the WG Group informed of progress while providing the necessary resources for the firm activities. The managing director is also the person who appoints the project leader at milestone 0 (M0).

#### **4.3.3.2. The group leader**

The group leader is the technical director managing a range of products. He/she delegates the implementation of new functions to the project leaders and must allocate the necessary resources. He/she must also ensure that the relevant procedures are applied to the engineering work and that appropriate solutions are found to cope with potential problems during NPD. The group leader, together with the managing director, appoints the project leader. The group leader is also the person who appoints the design engineer.

#### **4.3.3.3. The project leader**

The project leader is the person responsible for a specific project. He/she is appointed by the managing director and the group leader. He/she must manage the project so as to guarantee goal attainment and comply with delays. The project leader is the main actor for implementing the NPD



process. He/she must establish the project plan, prepare the milestones reviews, ensures that the objectives of the project are met and that procedures are respected throughout the whole process.

#### **4.3.3.4. The marketing manager**

The marketing manager is appointed by the managing director to define and implement a marketing approach in line with the division commitments. He/she must ensure that marketing decisions and planning comply with the project plan as well as with quality policies and procedures. He/she is also the person who starts new projects by submitting business cases or contracts and who appoints the product marketing engineer and spreads marketing resources among the different projects in progress.

#### **4.3.3.5. The product marketing engineer**

The product marketing engineer is under the responsibility of the marketing manager. He/she manages a range of products and is in charge of : product definition and launch, setting up the project plan with the project leader and implementing the necessary marketing tasks.

#### **4.3.3.6. The marketing communication manager**

His/her role is to prepare and produce all documents and media relating to the products developed by the division.

#### **4.3.3.7. The design engineer**

The design engineer carries out research and engineering in accordance with the objectives negotiated with the project leader.

#### **4.3.3.8. The quality assurance manager (QAM) and the project quality engineer (PQE)**

The responsibility of the QAM is to ensure that the level of quality is maintained in corporate activities and throughout the NPD process. The PQE acts as a quality consultant for the project leader throughout the NPD process.

#### **4.3.3.9. The manufacturing co-ordinator**

His/her responsibility is to co-ordinate marketing, engineering and manufacturing activities and to ensure that delivery dates for prototypes and production runs are respected. His/her role is also to gain feedback about the maintenance undertaken by service centres on the division's products.

#### **4.3.3.10. The financial controller**

He/she establishes the budget and controls expenses and margins for each project with a monthly reporting to the managing director.

#### **4.3.4. Conclusions**

The previous two sections, respectively dedicated to the written documents and to the people involved in the different NPD stages have stressed the heaviness of the process which will be detailed in the next part.

#### **4.4. The NPD process**

The ISO 9001 certification, obtained in January 1997, was a main factor explaining the formalisation of the NPD at WG. The organisation and scheduling of project steps was directly connected to the requirements of the ISO certification.

The NPD process is divided in eight cycles, ten phases and thirteen milestones showed in fig. 4.3. - brief guiding plan – and fig. 4.4. - detailed guiding plan -. In the detailed guiding plan, the codes that appear above each activity – e.g. T.00.01 – correspond to a quality template document which must



be completed by the person responsible for the action. The objectives of each of these documents are presented in the guiding plan description.

As mentioned at the bottom of fig. 4.4., some steps of the detailed guiding plan are optional whereas others are mandatory to pass the different milestones reviews.

Fig. 4.3.- Overview of product life model or brief guiding plan

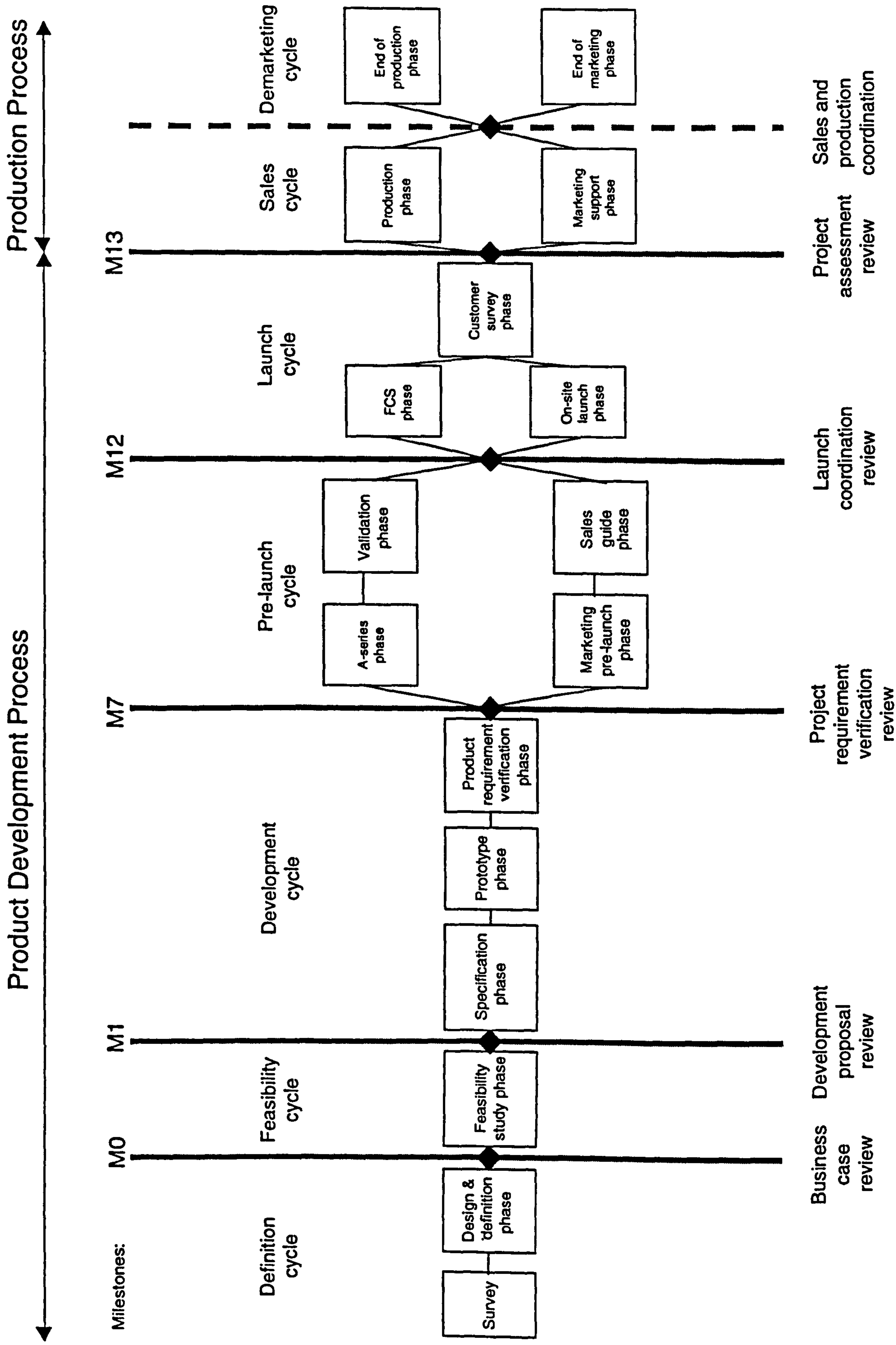



Fig. 4.4. - Detailed guiding plan from the survey cycle to the sales cycle

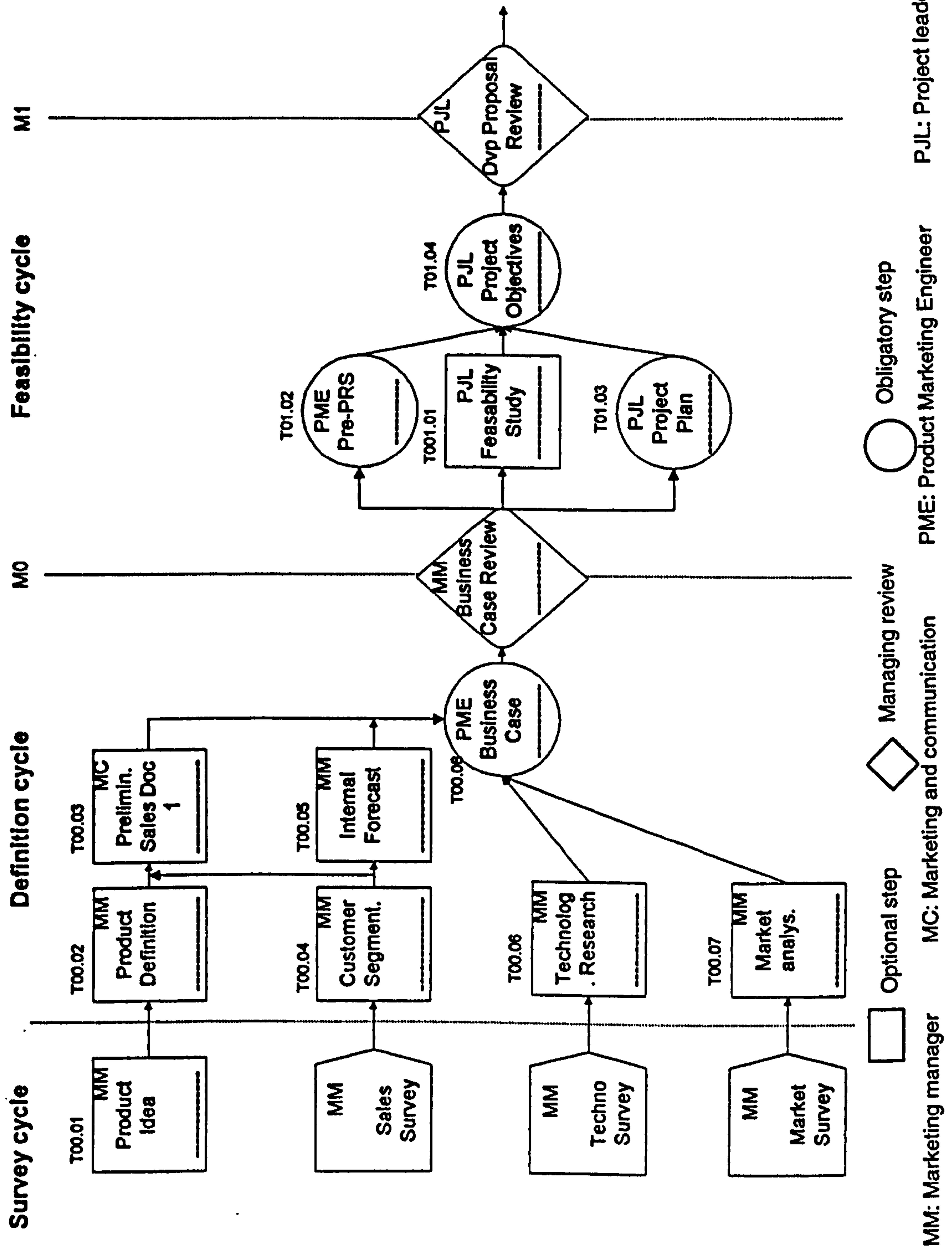

Fig. 4.4. (ctd) - Detailed guiding plan

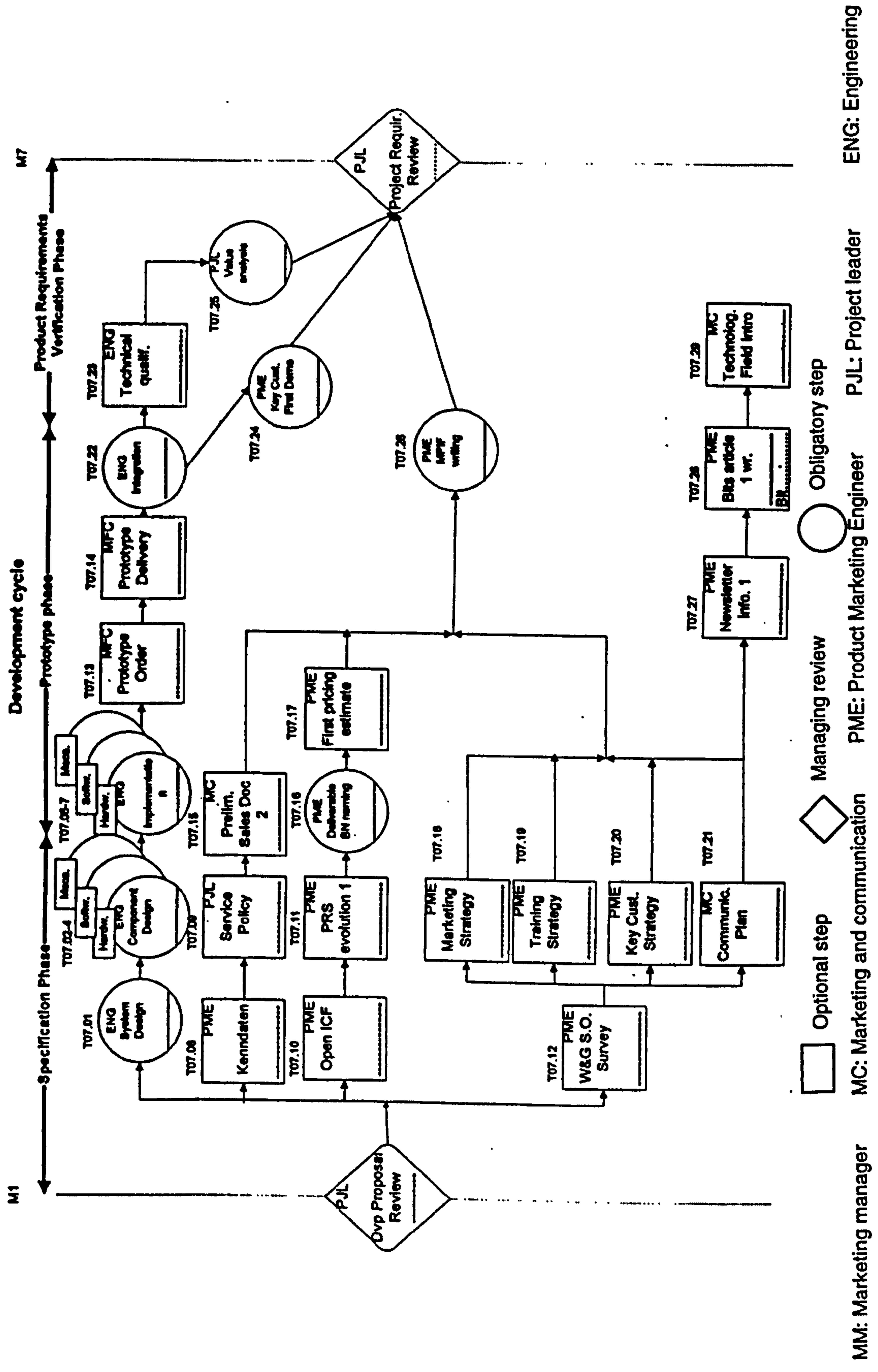
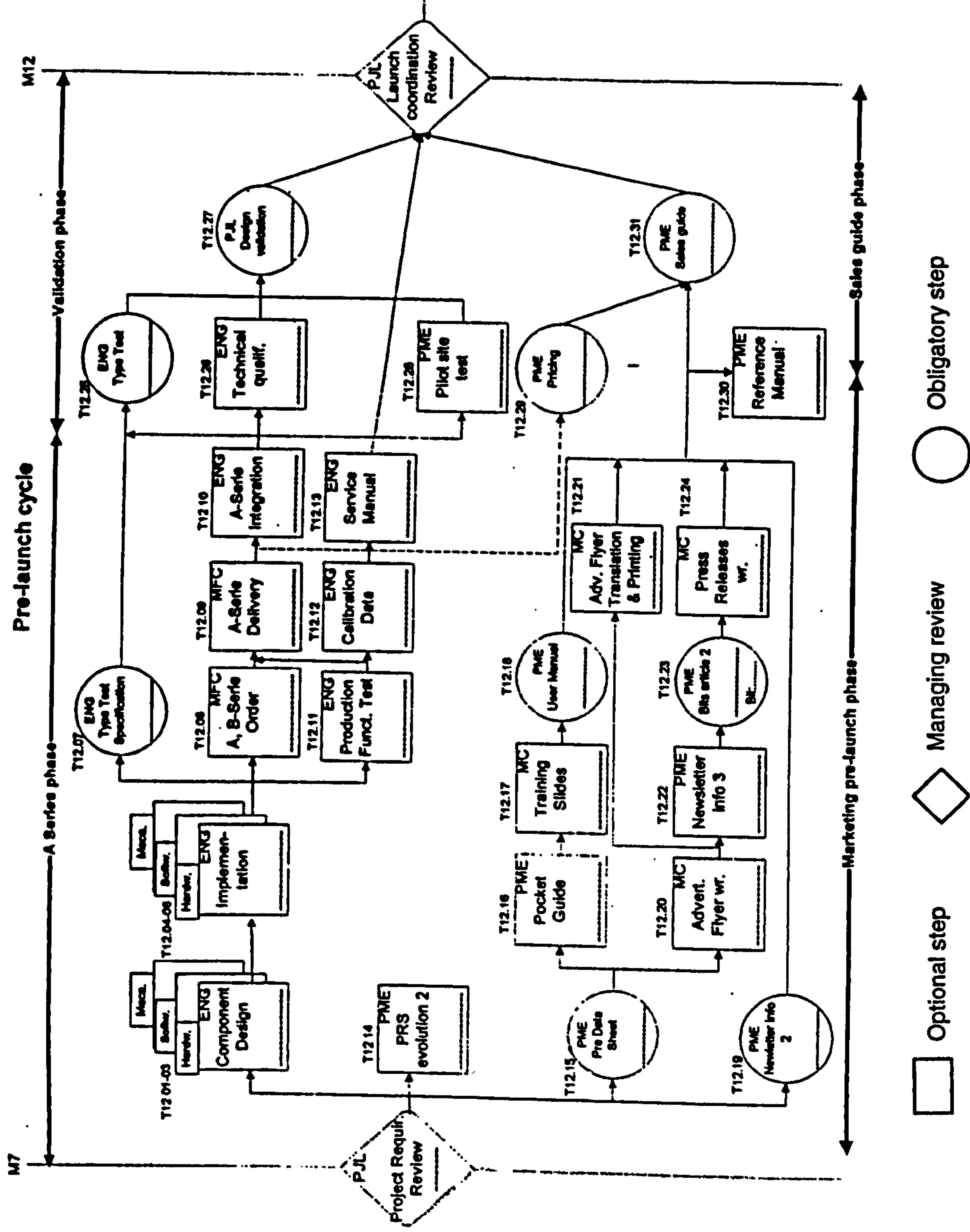

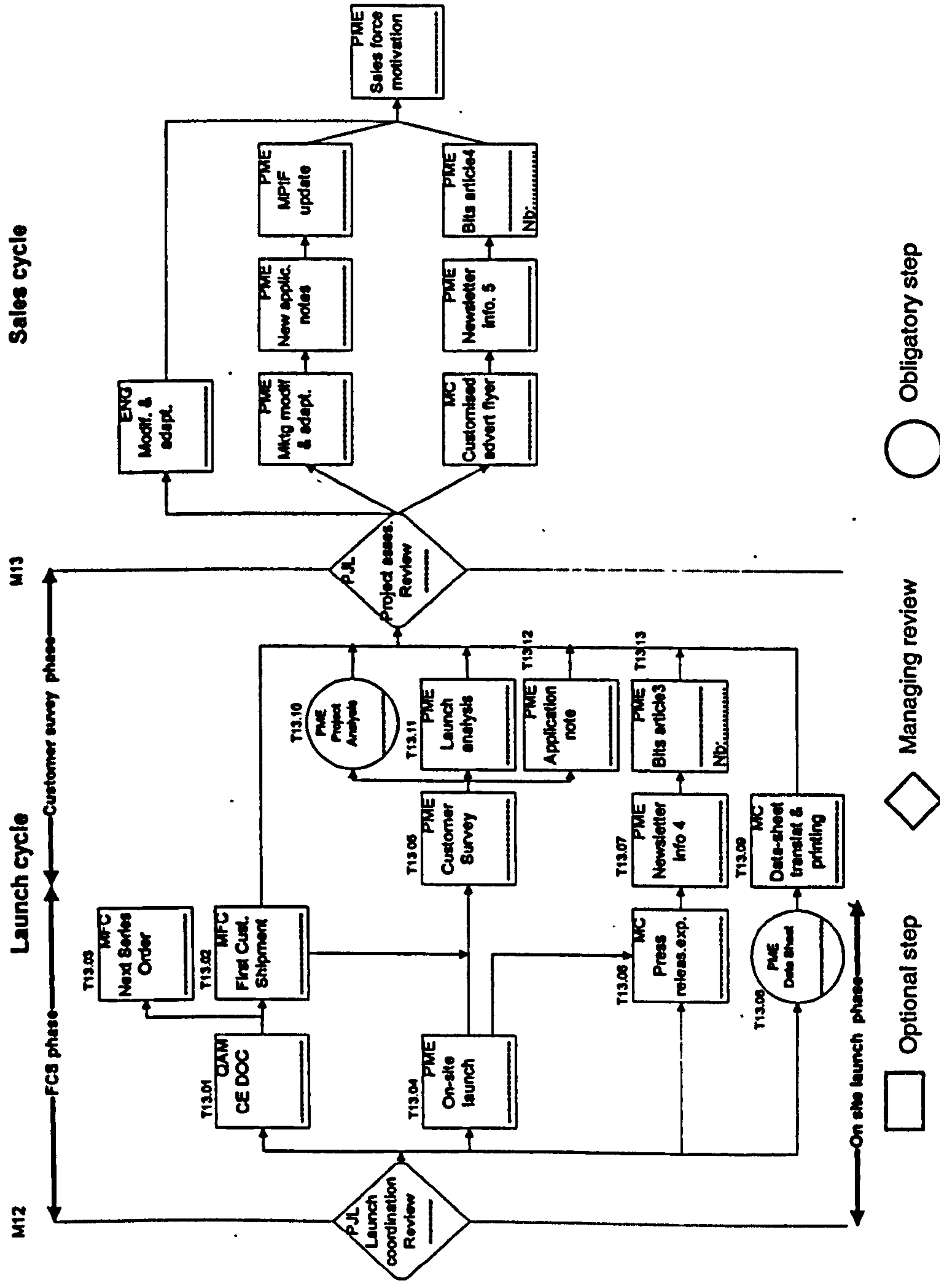

Fig. 4.4. (ctd) - Detailed guiding plan



MM: Marketing manager MC: Marketing and communication PME: Product Marketing Engineer P.J.L: Project leader ENG: Engineering MFC: Manufacturing coordinator

Fig. 4.4. (ctd) - Detailed guiding plan



QAM: Quality assurance manager MC: Marketing and communication PME: Product Marketing Engineer P.J.L.: Project leader ENG: Engineering MFC: Manufacturing coordinator



#### **4.4.1. Survey and definition cycles**

These two stages precede the milestone 0 which is based on the business case review and marks the starting point of the project.

The survey cycle encompasses:

- the generation of product idea;
- the sales survey;
- the technological survey;
- the market survey.

The marketing manager (MM) is responsible for the centralisation of all these information. The original product idea is issued either from a 'product idea' sheet – i.e. an idea submitted by an individual in the company, generally a product marketing engineer - or from a 'commercial and technical proposal' – i.e. an idea coming from the commercial or technological departments -. The first option usually concerns a new technological innovation that emerges and that will break through the market by being technology-pushed. In that case, the attitude of the firm is very proactive and the objective is to be first on the market. The second option is reactive, or "supportive" as mentioned by the marketing manager. It generally leads to new products based on a mature and more traditional technology which is totally mastered by the company and which results from years of experience and contacts with final users. Consequently, the NPD process will vary according to the type of new product the firm has to deal with. When a brand new technology is launched, the level of risk is much higher than in the case of an incremental innovation. The depth of upstream studies vary accordingly – i.e. the higher the level of risk, the deeper the necessary pre-development analysis -.

Human resource management, or "skills management" will also play an important role at that stage. Whenever a new innovation is to be launched, skilled engineers with a long corporate experience will be identified and involved in the project. Their roles will be both to master technological aspects but also to be able to convince other employees about the relevance of the project.

Once the new product idea is generated, the sales, technological and market surveys will then lead to the definition cycle which encompasses the following steps:

- the product definition and the establishment of a preliminary sales document;

- the definition of customer segment and sales forecast;
- the technological research;
- the market analysis.

According to the type of product idea generation, the definition cycle will be more or less formalised.

All these data will be integrated in the business case and lead to the business case review which is the starting point of the project (M0). This review is initiated by the MM. The objectives at that stage are to present the business case, to set the objectives of the feasibility study and to define the resources required. It is at this stage that the project leader (PJL) is appointed.

As regards NPD at WG France, an important point to be outlined is what is internally called 'rolling development'. In fact, once the first version of a new product is developed and launched on the market, incremental functions are added. This enables to launch the product early, to see if it answers customers' needs, and then to improve the product functions by offering further options to the customers (named version 2.00, version 3.00, etc.). However, it is to be noticed that the first version very often includes the main innovating function, as the customer's first question is almost always "What's new in this product?". Former functions may be added afterwards to the following versions of the new product. For example, for a given product, the first version (V1.00) may include function 1 that already existed in the previous product and function 4 that is a brand new innovation. V2.00 may then include function 1 and function 4 plus function 2 that also already existed in previous products.

#### **4.4.2. Feasibility cycle**

It is mainly under the responsibility of the PJL. The main objectives of this stage are:

- to consolidate the market estimates integrated in the business case;
- to establish the preliminary product requirement specifications (PPRS);
- to estimate development and manufacturing costs;
- to establish the project plan which will define project organisation and schedule.



This leads to M1, the development proposal review, initiated by the project leader, and during which a decision is made as regards the feasibility of the project and its launching or dropping. The issues to be considered at this stage are the following:

- will the project be profitable over a five-year period?
- are the technological and commercial risks manageable?
- is there a coherence between the project and existing products?
- will this project bring new technological and/or market inputs to the company?

If the conclusions are positive, the project is launched and an agreement is made over the employees responsible for the project and the necessary resources to be allocated.

#### **4.4.3. Development cycle**

##### **4.4.3.1. The specification phase**

This phase is mainly under the responsibility of the product marketing engineer – i.e. the person in charge of the range of products concerned by the project -. In the first stages of the specification phase, the following documents are used:

- the system design, established by the engineering team and which describes the technological solutions to the requirements specified in PPRS and PRS;
- the 'Kenndaten', which a list of the standards the product must comply with;
- the information collection file (ICF), which enables to collect the necessary information to write the MPIF and sales guide;
- the company's sales organisation survey, in which informal information obtained from the subsidiaries and relating to markets and competitors will be listed.

The above-listed steps lead to the following ones:

- as regards engineering, the team must implement a study of the following aspects: hardware, mechanical and software design;
- the project leader must define the service policy, i.e. the services that will be associated with the product, once launched on the market;
- a detailed description of the product's characteristics and constraints which will complement the PRS;

- as regards the marketing and communication aspects, the PME and the marketing / communication (MC) team must establish the marketing, training and key-customers strategies as well as the communication plan.

#### **4.4.3.2. The prototype phase**

It is the stage during which the first product prototypes are developed. It is initiated by the following steps:

- the implementation and testing of hardware, mechanical and software modules by the engineering team;
- the improvement of the sales preliminary document by the MC team;
- the labelling of the products – i.e. the Baunummer and Naming (BN) – managed by the PME, so as to be able to structure the range and forward orders.

The above-listed steps are followed by:

- the first pricing estimate (+/-15%), done by the PME;
- the ordering and delivery of the first hardware, mechanical and software prototypes in collaboration with subcontractors;
- the testing of these prototypes by the engineering department, these stages being co-ordinated by the manufacturing co-ordinator (MFC).

The prototype phase ends with the integration of the different modules, the verification of the overall functioning and the writing up of the MPIF co-ordinated by the PME. In parallel, the MC department is in charge of publishing the first articles relating to the new product to be launched.

#### **4.4.3.3. Product requirement verification stage**

This stage starts with the prototype technical qualification, during which prototypes are tested by the engineering team to ensure that there is no major risk when developing the A-series models.

It is followed by the demonstration of the new product prototypes to the key-customers, under the responsibility of the PME. The objectives being to check whether the new solution developed corresponds to customer requirements and to collect arguments that will then be used for the selling stage. This is done under a confidentiality agreement previously negotiated with the customers concerned. The project leader is then in charge of writing up the prototype value



analysis which is an overview of all the improvements that the product may require in the future version. It includes mechanical, industrialisation, electrical, functional, ergonomic and user interface assessments.

#### **4.4.4. The pre-launch cycle (M7)**

It is initiated by the project requirement verification review, under the responsibility of the P JL. The aim of this review is to check whether the initial project orientations are still adequate. The diagnosis is based on the preliminary prototype and market testing as well as on the MPIF and value analysis. It leads to recommendations as regards the pre-launch cycle and the number of A-series and B-series models to be developed.

##### **4.4.4.1. A-series phase and marketing pre-launch phase**

After the project requirement verification review, the PME is in charge of establishing the new PRS, further to the conclusions of the M7 review. In parallel, he/she is also responsible for the writing up of the preliminary data sheet, a four page report including the product main characteristics and advantages, which will be used to introduce the new product to the sales teams and first customers. The PME will also issue an internal newsletter announcing the launching of the new product to WG's staff. On the basis of the conclusions of the M7 review, the engineering department will complement hardware, mechanical and software specifications. This will be followed by the implementation of A-series.

As regards the marketing aspects, the next steps are:

- the writing up, by the PME, of a pocket guide– i.e. a document that synthesises the main product characteristics and intended to customers -, as well as a newsletter, a press article and a user manual;
- the writing up of a two-side advertising flyer by the MC team – i.e. a document that presents the product main competitive advantages and which can be sent to target customers – as well as the slides that will be used for training sessions.

In parallel, the engineering team is responsible for the design of a software test type specification which will enable to ensure that the product corresponds to the PRS. The MFC will be in charge of managing A and B series order, delivery and integration – i.e. the issue of a purchase order for the materials require for the A and B-series, the co-ordination of the manufacturing process and delivery, and the integration of the different software and hardware modules all together -. Concurrently, the engineering team will implement production functional tests and data calibration – i.e. procedures through which production will be tested -. This will lead to the writing up of a service manual including all necessary information as regards the way the product must be operated and repaired.

#### **4.4.4.2. Validation phase and sales guide phase**

The activities to be implemented during the validation phase are under the responsibility of the engineering team, the PME and the PJJ. The engineering team is in charge of the type test step – i.e. the functional validation of the final product to be launched on the market – as well as the A-series technical qualification – i.e. the validation of the A-series products in accordance with the standards specified in the 'Kenndaten' -.

In parallel, the PME is responsible for:

- the pilot site test – i.e. the product is submitted to a couple customers so as to be tested in an operational environment -;
- establishing the price lists and sending it to the sales organisations;
- writing up the reference manual which describes the product internal and external characteristics  
so as to be used autonomously.

The pricing list and the reference manual are used as a basis for the sales guide which is the reference document for the sales force.

The next steps of the validation phase are implemented by the PJJ who is in charge of writing the design validation memo, the objective of which is to synthesise all the previous tests and to guarantee that the product can be launched. The validation phase ends with the launch co-ordination review (M12), under the responsibility of the PJJ.



#### **4.4.5. The launch cycle**

It includes two main phases which are the first customer shipment (FCS) phase and the customer survey phase and starts with the launch co-ordination review (M12). The objective of this meeting is to validate the product design and to co-ordinate future actions, including on-site launch schedule and recommendation for the launch cycle. M12 review must confirm that there is no technical risk relating to the product launch, that the necessary marketing and communication tools are ready and that the objectives in terms of delivery, launch strategy and resources are feasible.

##### **4.4.5.1. The FCS phase and on-site launch phase**

The functions which intervene during these phases are: the quality assurance manager (QAM), the PME, the MFC and the MC team. First, the QAM is in charge of establishing the CE-mark declaration of conformity which assures that the product comply with the CE requirements. In parallel, the PME presents the launch plan to the sales organisations, major marketing subsidiaries and some target customers. This often takes the form of a special event. During the following step, the MFC sets up a schedule for the B-series and the following ones. He/she also makes sure that the FCS can start. At this stage, the MC team circulates press releases in order to communicate about the new product. The PME writes the final technical data sheet which presents the product and is aimed at customers.

##### **4.4.5.2. The customer survey phase**

This stage precedes the sales cycle. Its main objective is to validate the last points before the actual launch on all the targeted market. The PME is in charge of assessing customer satisfaction about the product. At the same time, he/she writes the fourth newsletter, followed by a new press article, while the MC team translates and prints the ultimate version of the data sheet, previously written by the PME. The customer satisfaction survey leads to the launch analysis and to the project management analysis, in which the PME must compare initial plans and final achievements so as to draw lessons for future launches. He/she also writes the application note which synthesises the main operating conditions and provides advice to solve typical operating problems. These different steps are examined at M13 during the project assessment review.

#### **4.4.6. The sales and demarketing cycles**

It starts with the project assessment review (M13), conducted by the P JL and the objective of which is to assess the way the project was conducted and to consider future developments. The engineering department and the PME then studies the necessary modifications and adaptations that will have to be implemented in the engineering and marketing fields. At the marketing level, the PME is also responsible for updating the application note and the MPIF. In parallel, the MC team updates the advertising flyer and the PME publishes the last newsletter and press article. The final step of the sales cycle is the sales force motivation – i.e. training, distribution of the necessary tools, etc. – which will enable to organise the product launch on the market. Sales and production are, at this stage, co-ordinated with the MFC.

The de-marketing cycle takes place when the product is withdrawn from the marketplace and/or replaced by a new version in which case the cycles re-start from the beginning.

#### **4.4.7. Conclusions**

The objective of the preceding sections was to precisely describe NPD at WG France in order to gain practical insight of the processes. In fact, it appeared that the procedures generated by the ISO certification are very heavy both as regards the organisational and functional aspects but also when considering the different documents to be filled in.

The next sections will be dedicated to the analysis of such process.

### **4.5 Analysis of overall NPD process at WG France**

#### **4.5.1. Positive aspects**

The NPD process which was described in the preceding sections is directly linked to the quality system and procedures and is very formalised. Each step of NPD is associated with a written document and is under the responsibility of a given person involved in the project. This enables any employee in the organisation to be able to refer to internal documents so as to know about his/her



role as regards NPD and the steps by which the process is guided. As stressed by the marketing manager, employees gradually get used to the formalisation of the product development stages on the basis of the above-mentioned documents and gain experience in filling in these documents. This progressively permits to reduce the NPD delays.

Another advantage of these 'templates' is that they oblige the different project members to carefully consider all the information needed to make a decision at each milestone review. Moreover, these documents also enable to sub-contract some chapters of the product study - e.g. market research can be done by a specialised agency while other tasks are done in parallel by internal entities -.

As regards cross-functional collaborations, exchanges between departments are formalised and made compulsory by the previously described NPD stages. This permits to avoid most of the disharmony syndromes developed by Souder (1981) – e.g. distrust, lack of interaction and lack of communication -.

Eventually, as concerns time-to-market, it must be noted that WG France sometimes collaborate with start-up companies so as to rapidly benefit from emerging technologies and reducing development delays. Once a technology is acquired by the company, products are launched on the market, which enables to benefit from customers' feedback and to improve the products (notion of 'rolling development'). However, when a new technology is adopted (such as multimedia), there is no access to the market, i.e. no direct information flow, for developing the first version of the product. Working with an original equipment manufacturer (OEM) enables, on one hand, to sub-contract the manufacturing of the product for the first version and to reduce original investments. On the other hand, the start-up that develops the product benefits from a well-established distribution network, which leads to a win/win situation. Afterwards, in case of a successful collaboration, the start-up company is taken over by WG. The advantages of the previously described co-operation are of two kinds. Firstly, it does not require any heavy investments in the first stages of product development. Investments are only done once the product has proved to be successful on the market and consist in taking over the start-up company. Secondly, there is a huge impact on the reduction of the product development process since R&D is done and mastered by the start-up company that does have the necessary know-how in the field of activity. It avoids WG starting a brand new activity when it considers entering a new technological field.

#### **4.5.2. Critical Issues**

As mentioned in the guiding plan introductory section, there exist both optional and mandatory steps within the previously described NPD process. In fact, after careful consideration, it appears that most steps are not obligatory. According to the marketing manager, this introduces some flexibility in the system since each project is different from the others and may not require as much formalisation. For example, when the project is initiated by a suggestion formulated by an employee of the company, the initial steps are more formalised than when the product idea comes from the technical, marketing or commercial departments. However, these numerous optional steps also create gloomy areas which are bypassed whenever projects are running behind schedules. For instance, the upstream steps included in the survey cycle do not have to be necessarily formalised before the business case is written up. This may eventually lead to heterogeneous inputs as regards the NPD process.

Despite of the optional steps, the NPD process is globally heavily formalised and flexibility is eventually somehow reduced by the different phases and reviews the project has to go through before being launched. In a sector which is submitted to high level of uncertainty, carefully considering the risk of a new product launch is undoubtedly necessary, nevertheless, reactivity is also crucial to remain competitive. The issue is, then, to find the most successful equilibrium between formalisation and reactivity.

##### **4.5.2.1. The informal process**

In parallel with the above-described formal NPD process, informal exchanges also take place within the organisation. According to the marketing manager, they are of tremendous importance at WG France where they are encouraged by open-space offices in each department. However, this physical proximity only concerns people from the same department. What was observed in situ is that the marketing team is on the ground floor whereas the R&D department is on the first floor and employees from each function tend to stay in their own offices. Eventually, informal exchanges are quite rare. Moreover, the fact that production is done on other sites is also a source of concern as regards inter-functional relationships during the NPD process.



However, regular meetings are also held within each department so as to favour exchanges. These meetings constitute some sort of intermediary steps within the formal NPD process and between formal milestone reviews but they are initiated by managers, which minimises their effects even though the lack of communication and interaction syndromes outlined by Souder (1981) are partly avoided. In fact, cross-functional exchanges are mostly formal and pushed by managers, rather than being 'natural'.

#### **4.5.2.2. Marketing orientation**

WG France benefits from good know-how in terms of marketing and sales, which directly impacts the general organisation of the division. The marketing department is well formalised with functions such as product marketing managers, business managers, people in charge of communication, etc. As stressed in the literature review, this is the first step towards a customer-oriented strategy. Moreover, with the help of an external marketing consultant, the marketing department has highly contributed to the writing up of the different quality procedures. In fact, unlike most high tech firms, the strategy of WG France, in general, and more precisely the NPD strategy, are predominantly guided by marketing. The guiding role of the marketing department is emphasised in the organisational structure as well as in the different procedures and documents (Guiding Plan, MPIF, etc.) related to product development. As shown in the guiding plan, the marketing function intervenes in the very upstream stages of NPD through the survey and definition cycles and it helps formalising the marketing research process. The decision to start a project is initially made on the basis of data gathered by the marketing department. Products or services are then developed to answer these market requirements and needs. According to the marketing manager, emphasising on customers' requirements is a good way to communicate with R&D people concerning product characteristics to be developed.

However, the question is: is the company mainly marketing-oriented – i.e. guided by formalised marketing procedures - or is it truly market-oriented? – i.e. guided by customer requirements – (Bouvard, 1998). In fact, it seems that marketing orientation prevails even though it can be argued that the formalisation of the NPD process is still quite young and that customer orientation has not already emerged as part of the corporate culture. In fact, when considering the NPD process,

customers are integrated during the development cycle once the main decisions have already been taken as regards the product concept. Even though their feedback is taken into account in the final product version, they are not directly integrated in the concept stages of product development, which may threaten product's fit with customers' requirements (Roberts, 1992).

#### **4.5.2.3. Links between Marketing and R&D**

WG France has taken organisational measures so as to favour exchanges between R&D and marketing through the project leader and product marketing manager who supervise the different stages of NPD. Each project involves:

- a project leader, from the R&D department;
- the marketing manager;
- a product marketing manager, from the marketing department;
- a project quality engineer, from the R&D department.

This guarantees a mix of both technological and marketing inputs throughout the NPD process. The product marketing manager and the project leader regularly exchange together and thus create a link between the marketing department and the R&D department. Furthermore, both the product marketing manager and the project leader must participate in all the milestone reviews. It means that a regular flow of information is maintained between the marketing department and the R&D department during the product development process. As mentioned in the Quality Manual, the product marketing manager, who is under the responsibility of the marketing manager "sets up, with the project leader, the project plan and implements the marketing tasks". Consequently, a heavy collaboration is required between these two people, which enables to create a direct link and flow of information between the R&D and marketing departments.

However, as outlined by the marketing manager, there are still some communication problems between R&D and marketing, and especially as regards customer needs. Typically, it is not always easy for the marketers to convince the engineers about the nature of customer expectations. Integrating customers in the early NPD stages would favour direct contacts between R&D and end users and make their requirements more concrete for the engineers. Moreover, it would avoid developing 'technological objects' instead of customer-focused solutions (Millier, 1997; 1989; Vogel, 1993).



#### **4.5.2.4. Training**

In order to increase cross-functional interfaces and, thus, the efficiency of the product development process, supplementary training in marketing and technical aspects could be considered for respectively R&D and marketing people (Thérin, 1998). This type of training usually becomes necessary in organisations that wish to improve the integration of R&D and marketing and improve the implementation and actual efficiency of their multidisciplinary work. In fact, in order to establish an efficient collaboration between the different functions of company (mainly marketing and R&D) it is necessary to share some common fields of knowledge.

In the case of WG France, since marketing managers are mainly engineers, no training is necessary for them to acquire supplementary R&D skills. However, it could be useful to formalise a technical training within the marketing & communication department in which there is no technical background. More precisely, technical skills have been informally gained through direct and regular exchanges with engineers but formal technical training has never been implemented at that level. Moreover, marketing knowledge could be more developed and formalised within the R&D department in order to improve the quality of exchanges with both the customers and the marketing department. This would eventually increase the area of knowledge sharing between the two departments, lead to better communication, enable more efficient teamwork and help to shorten the NPD delays.

#### **4.5.2.5. Multidisciplinary teams**

Even though exchanges already take place between R&D and marketing, the cross-functional aspect should be emphasised for more efficient product development, especially concerning the links with the manufacturing and after sales teams. In fact, the products developed at WG France, are manufactured by other divisions (in Germany, the USA and the UK), which makes it difficult to implement face-to-face collaboration. During the NPD process, the team involved sets the final characteristics of the product to be developed and this information is transmitted to the production department which is then responsible for establishing the “costs of goods” – i.e. manufacturing costs – which are given to the manufacturing co-ordinator.

Manufacturing problems are largely responsible in creating delays, especially since new technologies imply manufacturing constraints that are increasingly complex – i.e. technical uncertainty -. This increasing complexity in manufacturing operations requires an adaptation of the manufacturing functions (Viardot, 1994). They must be associated in the first pre-development activities so that potential manufacturing troubles are known and coped with in the upstream stages of NPD. Consequently, the best way to work efficiently with the manufacturing department is to create multidisciplinary teams integrating people from this department or, if not feasible due to distance constraints, to develop the information system in order to exchange the necessary data. In this context, the objective is to go from a partially horizontal organisational structure in which some function – mainly production - still work in their own field of skills to a totally integrated structure in which trans-functional relationships concern the whole organisation as shown in fig. 4.5.

**Fig. 4.5. - From a classical organisation to a multi-functional organisation**

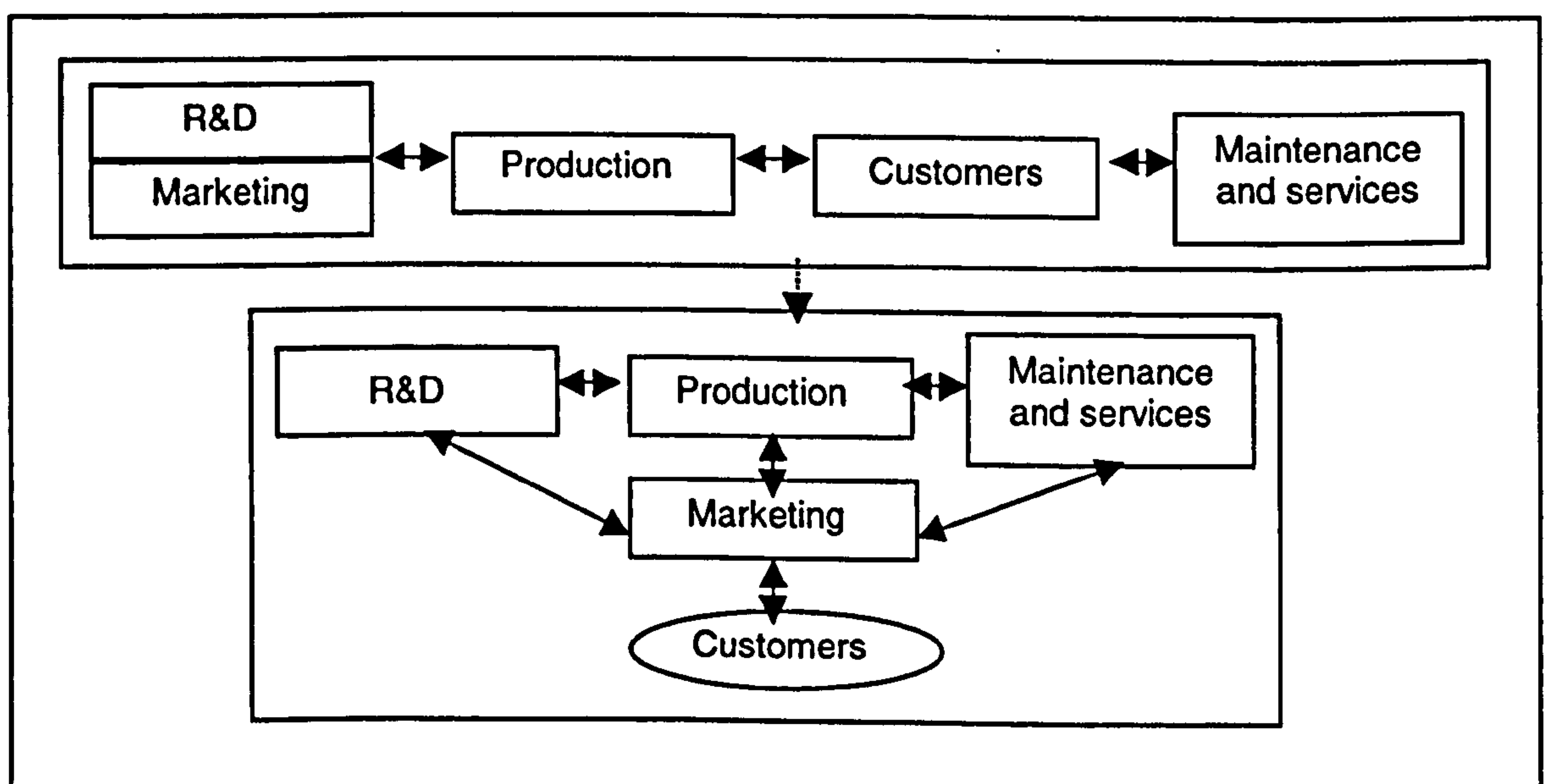

Source: adapted from Viardot (1994)

In the classical organisational model, R&D creates new products and develops prototypes; they are then transferred to the manufacturing department that purchases the required resources and manufactures the desired quantity of products. These products are sold thanks to the marketing department and then installed and repaired by the maintenance department.



In a high tech organisation that focuses on customers, departments exchange with one another at any time during product life. The marketing department acts as an interface with customers and other departments of the company. This enables to continuously improve the products by integrating customers' requirements. This organisation requires a flexible just-in-time production but guarantees a high level of quality and good after sales services (Viardot, 1994).

#### **4.5.2.6. Resource allocation**

Another observation that was made at WG France concerns resource allocation and especially human resources. Even if resources are planned per project, there is no transversal planning across the different pending projects within the company. Consequently, employees are involved in different projects at the same time and finally establish their own priorities in terms of the projects to be privileged in their timetables. This ends up by creating an individual time management, which finally generates bottlenecks and delays in the projects.

A solution, here, would be to work on the basis of a global planning of the different projects within the company, avoiding that a person works on too many projects at the same time. However, the marketing department is the main interface with the market. It is responsible for formalising data collection and has rigorous control over information. Even though the marketing department favours better management of the information system, it seems that it also increases the formalism of the NPD process. Moreover, other functions are dependent on marketing to have access to environmental and market data which tends to give marketing some control over other departments (Thérin, 1998).

#### **4.5.2.7. Marketing Information System (MIS)**

In order to be more informed about the market evolutions, it would prove efficient to improve information exchanges with the sales force. There already exists an information system named VIAS which enables information collection about the orders, but it is not well-managed and the information provided does not enable to develop a precise segmentation of WG's customers.

The MIS at WG does not actually provide any regular information about the external nor internal environments of the company. Globally, the data collection process is very informal and information is mainly transmitted by the product marketing managers who are in direct contact with end users. The main problem outlined by the marketing manager is that the company's network – i.e. sales agents, distributors, etc. – is very wide and that formalising data collection would mean having much too information to analyse. The marketing manager does not want to make the process heavier by asking all the intermediaries to provide formalised reports.

However, it seems that the organisation is much too focused on internal matters rather than really scanning what happens in its environment, including competition, customers' requirements, etc. Information collection remains too punctual and is not really formalised, which is dangerous in a sector submitted to rapid technological changes and high uncertainty. In fact, as stressed by Rochford et al. (1993) and Porter et al., 1995, reactivity supposes strong correlation between the firm and its environment. The information system as well as the organisational structure must be adapted in consequence. Information must be collected through permanent environmental scanning and the data must then be circulated among the people concerned. As concerns WG France, it appears that environmental scanning is not really formalised. Environmental signs are mostly detected once they are quite visible, which reduces the firm's reactivity on its markets.

The problems concerning marketing information are increased by the fact that the organisation is far from its markets due to the nature of its distribution networks. Indirect distribution including many intermediaries does not enable to directly gather information about market demand. Moreover, since salespeople sell products from different divisions, they usually make their own choice concerning the products to be sold in priority – e.i. the products that are the easiest to sell and with the highest margins -. This implies that the divisions do not want to increase the pressure on salespeople by implementing a formalised process of information collection. Moreover, salespeople want to keep the knowledge they have about customers to avoid, for example, direct contacts through the company's distribution network.

Consequently, WG loses information about market evolution and do not have any possibility of directly transmitting information to its customers. Even if the present solution works on the short/medium term, there is a heavy risk of not being able to plan strategic actions on the long term.



In parallel with upstream information flows, there is also a problem concerning downstream information from the after sales service. In WG's system, the complaints are transmitted directly to the sales force, which send the product to be repaired to the maintenance department and then send the bill to the division. However, the company is not directly informed of the nature of the complaints and no real analysis is done as regards technical problems.

#### **4.5.2.8. Downstream marketing actions**

An efficient management of the marketing information system would directly impact downstream selling as a clear identification of market requirements would enable to develop the right sales support, focusing on customers' needs. By integrating customers' needs, the company would be able to communicate in terms of 'solutions' rather than 'technical functions'. This is very important for different targets that do not integrate the technical aspects of the products but that are more appreciative of a solution to their practical problems. This is increasingly important since complex technologies are spreading rapidly among businesses whose core activities are not in the telecommunication field – e.g. public organisations, clinics, universities, implementing internal telecommunication networks -. Contrarily to 'early adopters' who are opened to brand new, and often intricate, technological innovations, later adopters are more sensitive to solutions that can be easily implemented and maintained. Regular data collection from the market would enable to develop the appropriate commercial tools, which would then be dealt with by the marketing and communication department which is responsible for sending the right commercial information to the right people.

#### **4.5.2.9. Problems issued from procedures**

It was previously outlined that formalised procedures within the company, which directly relate to the ISO certification, helped to improve the product development process. However, these procedures are strongly focused on internal aspects of product development and there are finally few links with the external environment, especially concerning market aspects. By formalising its product development process, the company somehow forgot about the necessary correlation that must exist between NPD and market requirements.

According to the marketing manager, the procedures provide a framework that will guide NPD. However, he also insists on the fact that employees' motivation will eventually be the most critical element to ensure high efficiency. In the case of WG France, formal written procedures directly relates to ISO requirements but improvements are required concerning customers' integration in the NPD process. Moreover, the NPD process mainly links R&D and marketing but the manufacturing department should also be integrated in the early stages. As concerns the information system, the sales force should be more directly involved so that the organisation gain deeper knowledge of the evolution of customers' requirements. Downstream of the MIS, the after sales and maintenance departments should also be directly consulted in order to better follow-up the product once launched on the market place. Consulting sales people and after sales/maintenance people would enable to have a more proactive approach, rather than reactive.

#### **4.5.2.10. Strong interventionism from top management**

Another point that must be mentioned is that, at WG France, there is strong interventionism from top management in NPD decisions. Much too often, WG France managing director has to make punctual and important strategic decisions that appear during the product development process. This finally leads to creating a gap between the pre-determined strategy and the projects which are actually developed. In fact, even though multidisciplinary project teams were aimed at following the entire NPD process with a high level of autonomy, interventionism and control from top management is still strong. As stressed by Smith and Reinersten (1991), tight control eventually leads to longer cycles. This is even more true in a context where heavy formalisation due to quality procedures overloads the NPD process.

#### **4.5.2.11. Design management**

As shown in the preceding sections, little consideration is granted to design at WG France. The so-called 'design engineers' in the NPD process, are not actually designers as commonly understood. They are responsible for the soft/hardware architectures but with no impact on aspects such as ergonomics or user interface. In fact, design is not a managerial priority and there is no clear internal statement relating to its role in the corporate strategy. Logically, there is no structure dedicated to design in the company. When changes are made in product design, they are pushed



by technical changes and not really by customers' needs. In fact, according to the marketing manager, the products developed by WG France are aimed at business-to-business markets and they do not require much design emphasis. They all consist in a 'box', or a basic phone, a keyboard and a screen that have not evolved in the last years (see appendix 1). "Form does not really matter" even though efforts are made to adapt the final shape of the product to its end users. For instance, basic ISDN testers which main objective is to test telecom lines in order to check whether they work or not – i.e. the so-called "go/no go" tools - are simple, light and easily transportable. On the opposite, products provided for laboratories, which integrate many complex functions and are not intended to be transported, are much bigger and heavy. However, this constitutes global adaptations. As previously stressed, design at WG is not derived from a clear strategy. It is not formalised, nor is it guided by a coherent corporate identity. Clearly, its added value has not been perceived by the managers. In fact, an external designer was consulted a couple years ago as regards the ergonomics and interface aspects but, according to the marketing manager, his role was mainly to validate decisions already made by the company and, thus, there was no impact on the design orientation of the company.

#### **4.6. Synthesis of findings and conclusions concerning WG France**

The main objective of this chapter was to raise issues relating to NPD in a high tech company so as set the basis of the exploratory questionnaire. Following this case study, the main points that appeared are:

- **As regards the NPD process:**

- quality certification increases the formalism of NPD processes;
- quality procedures set the overall framework for NPD but employees' motivation is the major factor of success;
- NPD is mostly formalised by the marketing department;
- multidisciplinary teams make people work together but in a formal context;
- the overall NPD process is marketing-driven;
- the engineering department is responsible for the interface with manufacturing but there are very few contacts with marketing;
- the production department should be involved in the early stages of NPD.

• **As regards the role of marketing:**

- marketing orientation does not mean market orientation;
- the marketing department helps to improve management of the information system;
- the marketing department helps to formalise NPD;
- there is a strong power of the marketing department in the NPD process.

• **As regards the information system:**

- data collection and communication throughout the organisation is not formalised;
- indirect distribution networks and sales agents increase distance with customers as well as the amount of information to be dealt with;
- the sales force, distribution network and the after sales/maintenance departments should be directly involved in the information system.

• **As regards management:**

- top management should clearly set corporate objectives and provide customer-oriented guiding vision;
- management should make sure that there is an efficient information system and that information circulate across departments and among the different 'actors' intervening in NPD;
- management should invite all the departments concerned in planning and formulation of projects;
- management should favour exchanges of expertise through appropriate organisational environment.

• **As regards design management:**

- it is not a priority in the corporate strategy;
- even though product design somehow varies according to the segments to be addressed, design is not considered to be really useful in a business-to-business context;

In fact, even though a marketing culture exists at WG France, the organisation remains very R&D and technology oriented and it is not always easy to attract engineers' attention towards the necessity of understanding market requirements. However, by comparison with average high tech



firms, WG France is heavily marketing oriented and this clearly appears both in the organisational structure and in the way product development is managed. But, in fact, WG's culture is marketing driven but not market oriented, which makes a difference. The marketing department plays a central role in NPD and has formalised most of the NPD stages, including environmental scanning. However, there are still improvements to be considered as regards customers' feedback and customers' integration during NPD.

In order to increase market awareness, management should first develop a clear customer-oriented guiding vision that should be shared by the entire organisation. Moreover, training of R&D and production engineers to marketing would be necessary so as to increase the width of the interfaces between functions.

From the very first stage of market survey and pre-development activities throughout the whole product development process, WG tries to deal in parallel with both R&D and marketing constraints which is a good point but other determining functions such as the sales force, the after sales and maintenance departments stay aside.

The formalisation of the NPD stages has enabled to carefully consider the whole process and to precisely determine the role of each employee intervening at the different levels. However, product development remains much too concentrated on internal aspects and the final perspective of answering customers' needs gets lost among heavy procedures. Consequently, there is still a need to develop and reinforce the market orientation in the company, in correlation with the development of the marketing information system. Even though WG France already has a strong marketing influence, its case still illustrates the problems that may be encountered by high tech companies that are heavily guided by technological aspects.

Eventually, design management is granted very reduced consideration and its strategic role has not been perceived by top management.

The issues that emerged from the observations made at Wandel & Goltermann, together with the literature review, laid the foundations of the exploratory survey, the results of which are presented in chapter 5.

## **CHAPTER 5: QUANTITATIVE SURVEYS**

### **5.1. Introduction**

This chapter will present the two quantitative surveys that were launched between 1998 and 2000 among the high tech companies operating in France. For each survey, the objectives and the methodology implemented (see also chapter 3) and the results obtained will be detailed. Key factors that emerged from the quantitative stages will, then, be integrated into the final model and will lead to further discussion.

### **5.2. Exploratory quantitative survey**

#### **5.2.1. Introduction**

The main objective of this exploratory stage was to make a diagnosis of the situation of the high tech companies operating in France in terms of product development and management of the interfaces between R&D, marketing and production since little information was available. Moreover, the purpose was to narrow the spectrum of the research on the most critical aspects of NPD in high tech organisations and to compare the data issued from the literature review and case study to the situation in the French high tech sectors. Finally, the objective was also to 'feed' the final model by providing an overview of the "real world situation" (Checkland and Scholes, 1990).

At this stage, the statistical analysis is mostly descriptive since the main purpose of the survey was to make an overall diagnosis of the current situation.

#### **5.2.2. Methodology and questionnaire**

##### **5.2.2.1. Methodology**

A questionnaire (see appendix 2) was mailed to all the high tech companies in France - i.e. 3006 organisations -, belonging to the sectors categorised as high tech and high/medium tech. The



unsolicited questionnaires were sent in the last quarter of 1998. 120 questionnaires were returned among which 107 were eventually exploitable, which means a return rate of about 3.5% - the average return rate being around 5% for unsolicited postal questionnaires, in France (Giannelloni and Vernet, 1994) -. In fact, when considering some of the letters that were returned, it seems that a large number of companies did not answer due to confidentiality constraints. Moreover, since the objective was to widely explore NPD in high tech companies, the questionnaire was quite long, which might have dissuaded some companies from filling it in. This may also explain the percentage of people who did not answer some of the questions (see limits of the research, chapter 6). However, it is important to outline that the original population of high tech companies provided by the INSEE was composed of 23% high tech companies and 77% medium-high and that the final sample follows these proportions with respectively 21.5% and 78.5%.

#### **5.2.2.2. Questionnaire**

The questionnaire was built on the basis of the knowledge gained in the previous stages, i.e. the literature review and the observations made at Wandel & Goltermann. During these stages, major critical factors had emerged which required further investigation in the context of the high tech companies operating in France. These factors were relating to:

- project management;
- the NPD process and trans-functional links;
- methods for shortening NPD delays;
- the management of information;
- marketing orientation;
- product success.

On the basis of the above-listed factors, the final questionnaire, which was mainly composed of close-ended questions for easier statistical and computer analysis (Giannelloni and Vernet, 1994), was divided in five main sections relating to:

- respondent's identity, the main objective being to check the level of reliability of the answers given;
- presentation of the company, including size, functions, certification, etc. ;
- R&D and organisational factors relating to project management and cross-functional co-operations;

- marketing and NPD, and more precisely, marketing and customer orientation, information system, priorities as regards new products, etc.;
- success of new products and factors considered to impact commercial achievement.

Before being mailed to all the high tech companies, the questionnaire was pre-tested among a sample of twenty managers in order to avoid misinterpretations (Giannelloni and Vernet, 1994). The necessary improvements were made according to their comments, mainly relating to wording or notions that needed to be explained – e.g. ‘multidisciplinary teams’ or the stages encompassed under the term ‘product development’ -.

### **5.2.3. Results**

This exploratory stage has enabled the researcher to get an overview of the situation of the high tech companies operating in France. The most relevant results are presented in the following sections and classified according to the following items:

- presentation of respondents and companies surveyed;
- management of NPD and inter-functional collaborations;
- information system;
- marketing orientation;
- customer orientation;
- commercial success of new products.

#### **5.2.3.1. Presentation of respondents and their companies**

- Respondents

Respondents are mainly managing directors (47.7%), followed by R&D managers (15%) and marketing managers (11.2%). Production managers only represent 3.7%. Miscellaneous respondents represent 22.4%, including human resource managers, finance managers, etc. Thus, a large majority of respondents (about 77%) are involved in managing tasks and are, therefore, aware of strategic, political and cultural corporate factors, which increases the reliability of the answers collected. Moreover, with an average of 11.6 years spent in their companies, respondent



have had a significant experience of their organisations, which also reinforce the value of the data collected.

- Companies

In terms of sizes, a majority of the companies surveyed – i.e. about 70% - have less than 200 people employed, a small proportion of companies have between 200 and 500 employees and about 17% have more than 500 people employed. These proportions somehow vary in comparison with the national spreading due to different reasons explained in chapter 6 (limits).

Concerning the structure of the companies surveyed, 97.2% have production sites and about 90% have 'formalised' marketing and R&D departments – i.e. with at least one executive employed<sup>1</sup> -.

This information was determining to be able to study the relationships that take place between R&D, marketing and production departments or functions.

As regards quality certification, 63.6% of the respondents are certified, and certification is in progress for 17.8%. The International Standard Organisation (ISO) certifications 9001 and 9002 are mentioned in a large majority of cases. With 81.4% of the companies concerned by a quality certification, the sector is above average. As concerns quality certification according to the size of the company, it must be outlined that about half of the companies employing <20 to 49 people are certified or in the process of being certified, whereas it concerns between 90 and 100% of larger companies.

- Conclusions

At this stage, it can already be considered that there will be organisational differences between small and larger companies. Since a high proportion of companies are concerned by quality certification, this point will have to be taken into consideration in further research stages, especially since it may impact on NPD formalisation.

---

<sup>1</sup> This criterion is used by the French Ministry of Industry in order to measure the level of formalisation of a department or function.

### 5.2.3.2. Management of NPD

- Sources of innovation
- *Importance of different sources*

Table 5.1. shows the importance granted to different sources of innovation.

**Table 5.1. - Importance of different sources of innovation**

Sources	Importance	Important or ext. important
Exchanges with customers		76.7%
Info. from the sales force		63.5%
Competitors' innovations		59.8%
Managers' intuition		49.5%
Suggestions from other departments of the firm		43%
Contacts with research centres		39.3%
Professional press/trade fairs		38.3%
Exchanges with suppliers		34.6%
Exchanges with sub-contractors		20.6%

N.B.: 5 other answers were given: R&D creativity, regulations and norms, environmental scanning and bids.

Exchanges with customers rank first with 76.7% of respondents who consider that it is 'important' or 'extremely important'. It is followed by the information provided by the sales force. However, collecting such information requires that a good marketing information system be implemented. As it will be stressed in a later section, it does not seem to be the case for all the companies. Then, competitors' innovations are considered to be 'important' or 'extremely important' for 59.8% of respondents. This also supposes good environmental scanning and efficient information systems in order to collect and analyse information relating to competition. However, contrarily to the first two sources, getting inspiration from what is done by competitors is not a proactive attitude but rather a reactive one which may be risky in markets such as the technology-intensive ones.

As concerns managers' intuition, it is 'important' or 'extremely important' for 49.5% of respondents. In fact, this outlines that product development decisions are not only rational but also influenced by subjective factors such as managers' intuition. This must be taken into account when analysing the product development process, especially since top management interventionism was identified in the literature review as a critical factor in NPD.



- *Role of manager's intuition in innovation and size of organisations*

The percentage of 'important or extremely important' answers respectively goes from 64.1% for companies with up to 49 employees to 34.8% for companies with more than 300 employees. The importance of manager's intuition decreases with the size of the company. Smaller organisations tend to be more influenced by management in their decisions relating to innovation than larger organisations. So, whereas there is no major difference as regards the importance of managers in R&D decisions when taking into account the size of the organisation, managers of small organisations tend to intervene more in the very upstream stages of the NPD process – i.e. at the innovation level -. In fact, the impact of the information system will be decisive, at that stage, in order to know whether top management has the necessary information to make decisions or whether decision-making is mostly 'arbitrary'.

- Multidisciplinary teams and inter-functional collaborations

Respondents could give several answers regarding the way their NPD processes are managed. 121 answers were given, which means that a certain number of companies have different ways of managing their NPD processes. For the largest proportion of companies, projects are managed with a multidisciplinary team approach – 56 answers out of 121, i.e. 46.3% -. However, NPD process based on autonomous departments, or managed according to a sequential approach, was mentioned 33 times – i.e. 27.3% -, followed by 'multidisciplinary teams intervening successively' in the product development process – 19 out of 121, i.e. 15.7% -.

When comparing the way projects are managed and the size of the organisations, the main difference to be noticed concerns the organisation by autonomous services which is more frequent in larger organisations – mentioned by 55.6% of companies with 500 to 999 employees and by 33.3% of companies with more than 1000 employees – whereas it was only mentioned by 27% of companies with <20 to 49 employees, 17.6% of companies with 50 to 99 employees and 28% of companies with 100 to 499 employees. In fact, larger organisations usually have more formalised structures than smaller companies, which explains that NPD is more compartmentalised. However, it must be stressed that even though the larger organisations still have very separated departments, they also manage their product development projects with multidisciplinary teams

– mentioned by 44.4%% of companies with 500 to 999 employees and by 53.3% of companies with more than 1000 employees -. Thus, frontiers that surround each function are thicker than in smaller organisations and departments are well-separated, but this organisational structure cohabits with multidisciplinary project management.

**So, multidisciplinary teams are the main way NPD is managed. However, it must be noticed that in larger organisations these multidisciplinary teams cohabit with well-separated and autonomous functions.**

Thus, multidisciplinary teams are implemented by both large and small organisations. However, how exchanges take place within these multidisciplinary teams according to the size of the companies will require further consideration. In fact, at this stage, it can be assumed that due to the existence of formalised departments, relationships are quite structured in large organisations whereas they will be more informal in smaller ones.

• *Links between R&D and marketing*

For 91.5% of the companies that answered the question, the links between R&D and marketing are perceived as 'important' or 'extremely important' – and for 88.7% of respondents, marketing is 'important' or 'extremely important' in R&D decisions -. Companies are very conscious of the necessity of inter-functional links between R&D and marketing. However, what is done to favour such exchanges must be investigated so as to see whether the facts actually support this statement.

The major difference in the importance given to R&D and marketing links according to the size of the company concerns 'extremely important' answers. In fact, the larger the organisation, the more important the links between these two functions – progressively going from 31.2% of 'extremely important' answers for companies with 50 to 99 employees to 81.8% for organisations of more than 1000 employees -. However, it must be noticed that the links between R&D and marketing were also considered to be extremely important for 66.7% of companies with 20 to 49 employees.

**So, links between R&D and marketing are important for almost all the companies but seem to be even more important for larger organisations and, to a certain extent, for smaller**



structures. In fact, it can be assumed that large organisations are aware of the difficulty to favour such exchanges in their structures, which explains why they consider it as being very important. On the other hand, these relationships naturally take place in an informal way in small organisations.

Table 5.2., shows the answers that were given concerning the types of links between R&D and marketing functions.

**Table 5.2. - Types of links between R&D and marketing**

<b>Types of links between R&amp;D and marketing</b>	<b>Nb.obs.</b>	<b>%</b>
<b>Meetings</b>	<b>70</b>	<b>65.4%</b>
<b>Written communication</b>	<b>54</b>	<b>50.5%</b>
<b>Informal exchanges</b>	<b>51</b>	<b>47.7%</b>
<b>Multi-disciplinary teams</b>	<b>47</b>	<b>43.9%</b>
<b>Exchanges through a manager</b>	<b>36</b>	<b>33.6%</b>
<b>Exchanges of electronic data</b>	<b>36</b>	<b>33.6%</b>
<b>Did not answer</b>	<b>12</b>	<b>11.2%</b>
<b>Others</b>	<b>2</b>	<b>1.9%</b>
<b>TOTAL OBS.</b>	<b>107</b>	

Respondents could give several answers. Meetings were mentioned by 65.4% of companies and are the main means of exchange between R&D and marketing. It is followed by written communication – mentioned by 50.5% of companies –, informal exchanges - 47.7%, and multidisciplinary teams – 43.9% -. Exchanges of electronic data as well as exchanges via a manager are equally mentioned by 33.6% of companies. Exchanges between R&D and marketing are mostly formal - i.e. meetings and written communication - Multidisciplinary teams including people from the R&D and marketing departments are implemented by less than half of the companies. Surprisingly for the sector, exchanges of electronic data are only mentioned by one third of the companies. However, this rate is likely to increase in the coming years with the spreading of information technologies.

As concerns the nature of the links between R&D and marketing compared with the size of the organisation, the importance of meetings as a major means of exchange increases in parallel with the size of the company. As for written communication and multidisciplinary teams, they are more frequently used in larger organisations. Exchanges of electronic information are also more frequent

in very large companies. As for informal exchanges, they are mentioned by about one quarter of companies with 20 to 49 employees and then progressively decrease for larger organisations.

Thus, the larger the organisation, the more formal the relationships between R&D and marketing and the more frequent the use of meetings, multidisciplinary teams and communication through electronic networks. In fact, at that stage, the assumption is that cross-functional collaborations are part of the corporate culture in small organisations where they take place in an informal way. On the contrary, in larger companies, cross-functional exchanges have to be formalised to occur – i.e. they are not spontaneous -.

• *Links between R&D and production*

For 66.3% of the companies that answered the question, the links between R&D and production are perceived as 'important' or 'extremely important'. A majority of companies are conscious of the necessity of inter-functional links between R&D and production. However, these links are considered to be less important than R&D/managing directors, R&D/marketing or R&D/customers.

The percentage of large organisations – i.e. with more than 200 employees – which consider that the links between R&D and production are 'important' or 'extremely important' is higher than for smaller structures – respectively around 90% and 50% -. The explanation provided for R&D/marketing interfaces also apply to R&D/production relationships.

The types of links between R&D and production are presented in table 5.3.

**Table 5.3. - Types of links between R&D and production**

<b>Types of links between R&amp;D/production</b>	<b>Nb. obs.</b>	<b>%</b>
<b>Meetings</b>	<b>79</b>	<b>73.8%</b>
Multidisciplinary teams	55	51.4%
Informal exchanges	54	50.5%
Written communication	52	48.6%
Exchanges of electronic data	46	43.0%
Exchanges through a manager	42	39.3%
Others	1	0.9%
Did not answer	7	6.5%
<b>TOTAL</b>	<b>336</b>	<b>-</b>



Respondents could give several answers. Again, meetings came first with 79 answers out of 336, followed by multidisciplinary teams and informal exchanges – respectively 55 and 54 -, written communication – 52 -, exchange of electronic data - 46- and, finally, exchanges via a manager – 42 -. Exchange of electronic data remains marginal. Companies consider that R&D/marketing links are important, but, in reality, multidisciplinary teamwork between R&D and production – i.e. 51.4% - is more frequent than for R&D and marketing – i.e. 43.9% -.

**Exchanges between R&D and production are primarily formal and mostly take place during meetings. However, this may be different according to the size of the company.**

Globally, formal means of communication such as meetings and written communication are mostly used by larger organisations. Informal exchanges are slightly more important in organisation with <20 to 49 employees. The larger the organisation, the higher the percentage of multidisciplinary teams. It can also be noticed that the use of electronic exchange of information also increases in parallel with the size of the company.

- *Importance of the board of directors, marketing, sales force and production in R&D decisions*

The following table shows the results relating to the importance of different actors in R&D decisions.

**Table 5.4. - Importance of different factors in R&D decisions**

<b>Factors</b>	<b>Importance</b>
<b>Board of directors</b>	<b>Important or extremely important 86.9%</b>
Marketing	72.9%
Sales force	53.2%
Production	47.7%

With 86.9%, the power of management in R&D decisions is higher than the power of customers – i.e. 76.7% -. The difference is even larger when comparing 'extremely important' answers - 48.6% as far as customers are concerned and 67.3% for managing directors -. The importance of managing directors in R&D decisions is also higher than the importance of the marketing department. As concerns the production department, it is 'important' or 'extremely important' for

47.7% of respondents. When compared to the importance of marketing – 72.9% - or even that of the sales force – 53.2% -, this is quite reduced. However, this must be compared with what is really done in the product development process. For example, production people are more involved in multidisciplinary teams than marketing people. Thus, it seems that companies are conscious of the fact that marketing should be important in R&D decisions. However, practice differs from theory.

**Whereas marketing is considered to be more important than production in R&D decisions, there are more direct links between R&D and production than between R&D and marketing – e.g. multidisciplinary teams -.**

There are no major differences according to the sizes of the companies even though it could have been assumed that the importance of managing directors in R&D decisions would be higher in smaller companies. However, as previously outlined, the role of top management as regards sources of innovation is more important in smaller structures.

Obviously, it is necessary that managing directors intervene in R&D decisions. However, this should be further investigated so as to know how they impact on such decisions. In fact, when considering their power in the R&D process, it seems that they have a decisive role to play by communicating about market orientations. It will also be relevant to see whether the importance given to management in R&D decisions is not a barrier to increase the level of R&D and marketing collaborations.

- *Links between production and marketing*

Links between production and marketing are considered to be less important than R&D/marketing and R&D/production.

Table 5.5. shows the types of links between production and marketing functions.



**Table 5.5. - Types of exchanges between production and marketing**

<b>Types of links between production/marketing</b>	<b>Nb. obs.</b>	<b>%</b>
<b>Meetings</b>	<b>61</b>	<b>57,0%</b>
Written communication	45	42,1%
Informal exchanges	41	38,3%
Exchanges through a manager	34	31,8%
Multidisciplinary teams	30	28,0%
Exchanges of elec. data	28	26,2%
Did not answer	23	21,5%
Others	1	0,9%
<b>TOTAL</b>	<b>263</b>	<b>-</b>

Respondents could give several answers. Meetings and written communication are the first two types of exchanges that were mentioned. Informal exchanges were mentioned by 38.3% of respondents and multidisciplinary teams by 28%. Again, exchanges are mostly formal.

Whereas R&D and production departments in larger organisations tend to have more formal exchanges than in smaller structures, they also have more exchanges taking place through multidisciplinary teams.

**R&D/marketing and production relationships mainly take place during meetings and are, consequently, mostly formal.**

- Formalisation of product development

Among the respondents, 54.2% have a product development process that is totally formalised by written procedures, 29.9% have a product development process that is partly formalised by written procedures and 9% of the companies surveyed do not have any written procedures.

25.7% of companies with up to 49 employees have no written procedures at all to formalise their NPD process. This percentage is reduced to 0 for all the other companies. The NPD process is totally formalised for a very high percentage of larger organisations – respectively 88% of companies with 100 to 499 employees, 100% of companies with 500 to 999 employees and 90.9% of companies with more than 1000 employees.

**The larger the organisation and the more formalised the NPD process.**

- Priorities in NPD

**Table 5.6. - Priorities concerning NPD**

<b>Factors</b>	<b>Importance</b>	<b>Important or extremely important</b>
<b>Meeting customers' requirements</b>		<b>87.9%</b>
<b>A reliable product</b>		<b>81.3%</b>
A user-friendly product		62.6%
A global solution		61.7%
A product easy to manufacture		49.6%
An innovative product		48.6%
A high tech product		41.2%
An aesthetic product		34.6%
A wide range		31.8%

The main priority during the NPD process is to answer customers' requirements. This outlines the fact that companies are conscious of the necessity to have a customer focused strategy. It also stresses the need for efficient management of the information system so as to gain deep knowledge of the nature of market requirements. However, further investigation is needed to know how customers' needs are concretely integrated in the NPD process.

The second priority is product reliability. This must be taken into account when analysing the NPD process since it will impact, for instance, on the testing stage. This is in accordance with the importance granted to prototyping – i.e. 80% of the companies surveyed use this means to consult their customers -. It will also impact on the relationships between R&D and production since reliability will partly depend on the manufacturing process. Moreover, it will have to be taken into account when analysing design issues.

User-friendliness is mentioned as the third priority, but quite far from the previous factors. Again, this will have to be taken into account when considering the role of design in the NPD process since the use of design will impact on the level of user-friendliness of a product. It also supposes strong integration of customers in the NPD process and, more precisely, in the testing stages.

61.7% of respondents consider that developing a global solution is 'important' or 'very important' during the NPD process. Companies are conscious of the necessity to develop a global offer including, for instance, complementary services, which shows the emergence of customer-oriented priorities.



What can be mentioned as concerns the following factors presented in table 5.6. is that innovation and technology do not come first in the list of priorities. This has both positive and negative consequences. First, it is interesting to see that the 'technological challenge' is not the only motivation that guides the NPD process in high tech companies. However, in such sectors, launching products with strong innovative and technological inputs may be decisive to be leaders on the market.

As concerns easiness of manufacture it is interesting to see that it comes at the middle of the list with about one half of the respondents who consider that it is 'important' or 'extremely important'. Again, this requires exchanges between R&D and production. It will thus be relevant to analyse aspects such as the role of DFM and DFA in the high tech companies operating in France.

As regards aesthetics, it is also important to stress that this factor was only mentioned by about one third of the respondents as being 'important' or 'extremely important'. This will have to be analysed more precisely in the context of design management since, as stressed in the literature review, an aesthetic product is more appealing and, thus, usually sells better. Aesthetics is also a way of emphasising technological characteristics and of making the product user-friendlier which is of tremendous importance for high tech products.

Finally, developing a wide range of products only got around 30% of 'important or extremely important' answers.

Consequently, it appears that companies have integrated the fact that meeting customers' requirement is the number one of NPD priorities. But further investigation is needed to understand how customers' requirements are concretely dealt with throughout the NPD process. Quite surprisingly, innovative and technological aspects are not considered as being that important. From a general point of view, priorities as concerns the NPD process will require that R&D, marketing and production departments co-operate, which corroborates the research objectives. Moreover, design management will directly concern factors such as reliability, product user-friendliness and manufacturability.

- *Financial investments during the NPD process*

The next table shows the importance granted to different factors as regards the budget allocated in NPD.

**Table 5.7. - Importance of different criteria in terms of budget allocated in NPD**

<b>Investments in:</b>	<b>Importance</b>
	<b>Important or extremely important</b>
<b>R&amp;D</b>	<b>70%</b>
<b>Prototypes</b>	<b>62.7%</b>
<b>Manufacturing process</b>	<b>56.1%</b>
<b>Sales force</b>	<b>43%</b>
<b>Quality procedures</b>	<b>43%</b>
<b>Advertising and communication</b>	<b>41.1%</b>
<b>Engineering</b>	<b>40.2%</b>
<b>Market research</b>	<b>38.3%</b>
<b>Administration</b>	<b>12.1%</b>

Budget is allocated in priority to technological and technical aspects, including R&D, prototypes and manufacturing process. Market research investments emerge among the last priorities.

Even though it is understandable that technical aspects require heavy investments in technology intensive sectors, it is paradoxical that market research comes penultimate in terms of investments, when considering that the business environment is very risky and that the impact of customers is perceived as being decisive in the NPD process.

- *Factors to decide that a new product will be launched*

Table 5.8. shows the importance granted to different factors in order to decide that a new product will be launched.



**Table 5.8. - Factors to decide that a new product will be launched**

Importance	
Factors	Important and extremely important
Product technically ready	90.4%
Increasing demand from customers	86.1%
Market study positive	71.5%
Commercial support ready	58.7%
Strong pressure from competitors	55.5%
Deadline reached	33.8%

The first criterion is technical readiness, which corroborates both the fact that reliability was mentioned as a priority as regards NPD and the fact that R&D, prototypes and manufacturing process are priorities in terms of budget allocated. The technical aspect is shortly followed by 'increasing demand from customers', which supposes a reactive, rather than pro-active attitude. However, 'pressure from competitors', which is another reactive attitude, only ranks fifth out of seven criteria. As concerns market research, it is decisive for a large majority of companies even though figures have shown that it is often weak in the NPD process.

As regards commercial support, it does not seem to be such an influential factor to decide about a new product launch. This corroborates the literature which stressed that technology is a priority in high tech sectors and that commercial aspects are usually integrated in the late stages of the product life cycle.

Finally, only about one third of the companies surveyed considered that the fact of having reached the deadlines will impact product launch decision. In fact, the next section will provide more information relating to NPD delays.

- Shortening NPD delays

Shortening the NPD delays is considered to be important or extremely important for about three quarters of the companies. Around 45% of the companies consider that they had shortened their NPD delays in the last three years – i.e. between 1995 and 1998 -, which outlines the strategic impact of the time-to-market issues.

Table 5.9. provides a list of the factors that are considered to be 'important' or 'extremely important' in order to reduce the NPD delays.

**Table 5.9. - Factors to reduce NPD delays**

<b>Factors</b>	<b>Importance</b>
<b>Collaboration R&amp;D/marketing</b>	<b>85.5%</b>
<b>Collaboration R&amp;D/production</b>	<b>83.7%</b>
<b>CAD</b>	<b>77.5%</b>
<b>Upstream studies</b>	<b>76.9%</b>
<b>Upstream integration of customers</b>	<b>67.3%</b>
<b>Formalised procedures</b>	<b>64.9%</b>
<b>Upstream integration of suppliers</b>	<b>58.7%</b>
<b>Collaboration production/mark.</b>	<b>57.3%</b>
<b>Standardising components</b>	<b>50%</b>
<b>Improvement of production equipment</b>	<b>44.9%</b>
<b>Upstream integration of sub-contractors</b>	<b>41.3%</b>
<b>Specific training sessions</b>	<b>41.8%</b>
<b>Reducing the number of prototypes</b>	<b>38.9%</b>
<b>Development of information system</b>	<b>38.7%</b>
<b>Financial incentives</b>	<b>1.1%</b>

Collaboration between R&D and marketing and R&D and production were mentioned first as ways of shortening the NPD process. So, forms of inter-functional co-operations must be favoured within high tech organisations. However collaboration between marketing and production is not considered as a priority. This emphasises previous results which have already stressed that inter-functional exchanges during NPD mainly take place between marketing and R&D and/or R&D and production.

Computer-assisted design is also a determining factor. This must be taken into account when analysing the role and input of design management in relation to NPD.

Companies also stress the role of upstream studies as a way to shorten NPD delays. However, these studies are certainly be more technical than commercial since the development of information systems was only mentioned by 38.7% of respondents as a factor that helps reducing NPD delays.

Upstream integration of customers was also mentioned by a majority of companies. However, previous results showed that their integration in multidisciplinary teams is marginal. In fact, customers' integration must be mostly informal.



As regards formalised procedures, they are definitely considered to have a role to play in the reduction of NPD delays. However, this must be carefully analysed. In fact, as stressed in chapter 4 (Wandel & Goltermann), procedures certainly provide 'templates' to maximise experience from one product launch to another. However, too many procedures may also increase heaviness of processes, reduce flexibility and finally increase delays.

The fact that component standardisation was mentioned by half of the respondents outline the necessity to focus on the role that design can play as regards manufacturing – i.e. DFM, DFA, etc. -. The same remark can be made as regards the reduction of the number of prototypes.

Finally, the role of the information system is, again, under-estimated. In fact, the idea behind this question was that permanent environmental scanning and regular contacts with end-users provide an information basis that can be used at any time, thus helping to be pro-active, and, eventually, leading to a reduction of delays. However, only about 1/3 of the companies surveyed consider that it can be efficient.

**Once again, it appears that high tech companies are not really conscious of the decisive role of the information system in their organisations. However, they are aware of the necessary collaborations that must be implemented between R&D and marketing as well as between R&D and production. Concerning customer orientation, most companies are conscious that upstream integration in the NPD process will enable them to shorten delays. In parallel, formalised procedures also appear as being important in the NPD process. Finally, as regards design management, factors such as CAD and standardisation of components were mentioned by more than half of the respondents as impacting on delays.**

#### • Conclusions

Multidisciplinary project management already exist in about half of the organisations surveyed. Moreover, companies are globally conscious of the necessity to develop inter-functional links. However, relationships between R&D, marketing and production are mainly formal, especially in large organisations. Further investigation will be required on this matter since at this stage, it seems that co-operations is not 'natural' or 'cultural' but rather guided and even made mandatory

by internal organisational aspects. In fact, NPD is, on average, highly formalised with more than half of the companies surveyed having a process which is totally guided by procedures. What is more, top management considers that they play an important role in both the R&D and innovation process, which emphasises the notion of control and formalism. Even though technical aspects are seen as critical in the NPD process, companies are highly conscious that meeting customers' requirements is the number one priority to be reached. Moreover, factors such as reliability and user-friendliness are also considered to be decisive. This paves the way for further investigation concerning the role that design management can play to emphasise customer-orientation by matching market demand and expectations as regards product characteristics. These issues will be developed in the second quantitative survey.

### 5.2.3.3. Information system

Tables 5.10. and 5.11. show the results relating to the existence of formalised procedures to collect field information and information from after sales services.

**Table 5.10. – Are there formalised procedures to collect field information in your company?**

Formalised data collection	Nb. obs.	%
Yes	76	71%
No	22	20.6%
Did not answer	9	8.4%
<b>TOTAL OBS.</b>	<b>107</b>	<b>100.0%</b>

**Table 5.11. – Are there formalised procedures to get information from the after sales service?**

Information from after sales service	Nb. obs.	%
Yes	72	67.3%
No	21	19.6%
Did not answer	14	13.1%
<b>TOTAL OBS.</b>	<b>107</b>	<b>100.0%</b>

On average, 20% of the high tech companies that answered the questions do not have any formalised procedure to collect field data and to get information from the after sales service. Again, this is not adapted to the high level of uncertainty of the high tech fields. However, it is important to notice that the smaller the companies and the higher the number of 'no' answers.



Whereas among companies up to 49 people employed, about 47% do not have any formalised procedure to collect field information, this percentage does not exceed 11.5% for larger companies – i.e. with more than 100 employees -.

**The smallest organisations have the least formalised field data collection.**

Proportions are globally the same as far as information coming from the after sales service is concerned. The process is not formalised for 35.9% of companies up to 49 people and this percentage reaches a maximum of 17.4% for larger organisations.

Concerning formalised measures of customers' satisfaction, 60.7% of the sample have such measures but, on the opposite, 31.8% do not have any procedure of this kind. This globally corresponds to the number of companies that have a quality certification – i.e. 63.6% -. 53.1% of companies with 20 to 49 employees answered 'no' and this percentage globally decreases when the size of the company increases. It reaches 0% for companies with more than 1000 employees.

**So, larger companies tend to have more formalised measures of customers' satisfaction.**

- Conclusions

Thus, the formalisation of the information system is linked to the size of the company with a clear frontier between companies with less than 50 employees and larger companies. However, from a global point of view, data relating to information systems and to customers' satisfaction measures show important weaknesses when considering the high levels of uncertainty that threaten high tech organisations. Moreover, when considering that meeting customers' requirements is clearly a priority, it appears that some efforts still have to be made.

#### 5.2.3.4. Marketing orientation

About 70% of the companies consider that their marketing orientation is already 'important' or 'very important'. However, more than 60% also consider that their marketing orientation strongly needs to be improved. As regard the link between the size of the company and its marketing orientation, smaller companies tend to have a weaker marketing orientation. Marketing orientation is 'important' or 'extremely important' for about 60% of companies with less than 50 people, whereas this percentage is around 75% for companies with 50 to 99 employees and companies with more than 300 employees. It reaches more than 90% for companies with 100 to 299 employees.

- *Training in marketing*

**Table 5.12 - Has there been marketing training in the past three years?**

Marketing training	Nb. obs.	%
Yes	56	52,3%
No	42	39,3%
Did not answer	9	8,4%
<b>TOTAL</b>	<b>107</b>	<b>100,0%</b>

**Table 5.13. - People receiving marketing training**

Concerned by marketing training	Numbers	%
Did not answer/no training	51	47,7%
<b>Salespeople</b>	<b>45</b>	<b>42,1%</b>
<b>Marketing people</b>	<b>43</b>	<b>40,2%</b>
R&D people	29	27,1%
Managers	18	16,8%
Production people	12	11,2%
All the executives	8	7,5%
Others	0	0,0%
<b>TOTAL</b>	<b>206</b>	<b>-</b>

About half of the companies had marketing training between 1995 and 1998 and it mostly concerned salespeople and marketing people. So, the objective was not to develop the marketing culture among other departments but mostly to increase the skills of already marketing-oriented employees. This is likely to increase the gap that already exists between the different 'internal



cultures'. However, it must be outlined that more than ¼ of the companies surveyed had trained their R&D employees in marketing. However, only 11.2% of people from the production departments received such training.

- *Background of people in charge of marketing*

About 45% of people in marketing departments have a commercial background, whereas around 55% have a technical background. It can be assumed that the educational and professional backgrounds of the people employed in the marketing department will influence the way marketing is managed in the organisation. However, at this stage, the data collected did not enable to observe significant dependence.

- Conclusions

**Some efforts are already made to develop a marketing-oriented culture but, according to the companies surveyed, they need to be carried on. Marketing orientation is weaker in smaller organisations. Moreover, as far as marketing training is concerned, it is mostly directed at marketing or sales people. This reinforces their skills but, as stressed in the literature review, it does not favour integration with other departments (Souder, 1981).**

#### **5.2.3.5. Commercial success of new products**

- *Percentage of products launched compared to number of concepts studied*

Among respondents, 80.2% launch more than half of the concepts they study. This means that initial evaluation and filtering of ideas is quite selective. This can be explained by the fact that developing a product concept in high tech sectors is very expensive and, thus, ideas must be tested and selected very upstream of the development process. However, this also outlined the needs for efficient concept-testing.

- *Percentage of successful products compared to the number of products launched*

Among respondents, 91.5% of companies have a success rate superior to 50%, among which 51.8% have a success rate of more than 75%. This is much above average when compared with the figures given in the literature – i.e. about 20% of successful launches -. However, it must be noticed that the questionnaire was sent to companies with more than 20 employees, which excluded very small organisations such as start-up in which there is a higher rate of failures. Moreover, as stressed in the literature review, the notion of commercial success could have been interpreted in different ways by the respondents – i.e. according to financial or non financial factors -.

- *Impact of different factors on products commercial success*

Table 5.14. shows the results relating to the importance of different factors as regards products commercial success.

**Table 5.14. - Impact of different factors on products commercial success**

<b>Factors</b>	<b>Importance</b>	<b>% Important and extremely important</b>
<b>Definition of customers' expectations</b>		<b>97.8</b>
<b>Product positioning compared to competitors</b>		<b>92.5</b>
Price		88.3
Technical characteristics of product		88
Delivery delays		87.8
Upstream collaboration with customers		84.8
Sales force		78.5
R&D stage		78.1
Services		75.6
Upstream collaboration between departments		68.9
Distribution network		65
Production stage		58.9
Market research		57.3
Marketing support		55.7
Product design		52.7
Advertising and com.		44.9

Again, the importance of defining customers' expectations has been well integrated by high tech companies even though it seems that practical implementation must be improved. As concerns the second and third criteria – i.e. product positioning compared to competitors and price – they obviously show that companies are conscious of the necessity to be competitive. Moreover, it



stresses the importance of an adequate marketing mix. However, technical aspects arrive just after as an important factor to succeed on the marketplace. As stressed in the literature review, design management can help to emphasise such features and this opens the way for further investigation. As concerns upstream collaboration between departments, it is also considered as contributing to product success.

Percentages granted to marketing research and marketing support show that they do not seem that decisive for companies. Here, a paradox must be stressed, which is that 'definition of customers' expectations' and 'product positioning' ranks first whereas market research does not appear among the first criteria. In fact, it seems that upstream collaboration with customers is the process through which most data about customers are collected, even though previous results showed that it must be mainly informal.

Finally, product design as well as advertising and communication arrive last in the list. The reduced importance granted to product design is another contradiction when considering that reliability and user-friendliness were mentioned as NPD priorities -. In fact, it seems that the role of design management to emphasise such factors has not been perceived by managers.

#### • Conclusions

**It appears that companies are aware that defining customers' requirements is the main priority to succeed on the marketplace. The results also confirmed the reduced importance granted to design in the French high tech companies. Moreover, market research and marketing and sales support arrive late in the list of priorities. This shows that the impact of marketing on NPD has not clearly been integrated by the respondents. Moreover, product design is also quite neglected as a competitive advantage.**

#### **5.2.4. Synthesis of findings and general conclusions**

The following key factors have emerged from the first quantitative survey:

- **Role of top management**

- The power of top management in R&D decisions is very important for the companies and is superior to the importance granted to marketing.
- Managers' intuition plays a decisive role in the innovation process, especially in smaller organisations.

- **Inter-functional links**

- Companies are very conscious of the necessity of inter-functional links between R&D, marketing and production.
- Collaborations between these departments are mentioned as the first factor which enables to shorten NPD delays.
- A large proportion of companies have implemented multidisciplinary teams even though their importance increases in parallel with companies sizes.

- **Formalism**

- Informal exchanges are more frequent in smaller organisations.
- The NPD process is more formalised in larger organisations.

- **Customer-orientation**

- A majority of companies are conscious of the necessity of linking R&D and customers and consider that customers are crucial in R&D decisions. These exchanges mainly take place between managers in small organisations, whereas the sales forces and the marketing departments tend to ensure this interface in larger organisations.
- Exchanges with customers is an important source of innovation.
- Meeting customer requirements is a priority for a very large proportion of companies.



- **Marketing**

- Most companies consider that their marketing orientation is already strong but they also consider that it still needs to be improved.
- Market research, marketing support and advertising/communication are the last factors that were mentioned when considering what affects product commercial success.

- **Marketing information system**

- Information systems are still weak for about 20% of companies – mainly small organisations - not having any formalised data collection process.
- Moreover, market research arrives among the last priorities in terms of investments during NPD and still about 1/3 of the companies do not have any formalised measure of customer satisfaction.

- **Design**

- Design is not considered to highly impact on product commercial success even though reliability and user-friendliness are considered to be priorities during NPD.

Firstly, informality is rare in large organisations where most exchanges occur during meetings or through written documents. This lack of informal relationships, especially between R&D and marketing, was listed by Souder (1981) as one of the major characteristics of the “lack of interaction syndrome” – see section 2.4.4. -. However, informality is more present in small companies. Thus, there are organisational differences according to the size of the firm. The difference that exists between large and small organisations in creating an informal atmosphere that favours successful design was outlined by Cooper et al. (1997).

Secondly, management is very present in NPD decisions, which is described by Walker (1993) as “a source of destructive criticism and hierarchical pressure”. Intervention and control from top management tend to increase the level of formalism of NPD. To a certain extent, management may, thus, contribute to reduce NPD and design management efficiency. However, the type of management control in NPD process also varies according to the size of the organisation.

Thirdly, when looking at the marketing information system, it appears that information flows are not well-managed and that the corporate vision of users' needs is not really clear. The upstream

integration of market and marketing aspects in the NPD is weak. This obviously threatens companies on the long term. Moreover, customers should be considered as a central element of a company's shared culture. This supposes to gain better knowledge of their expectations, to transmit this knowledge to the entire company, and to clearly integrate it in the corporate identity. As stressed in the literature review, design management can help, first, to improve the marketing information system and, then, to develop and strengthen a customer-oriented culture. Eventually, design also enhances the added value incorporated in the product and enables the organisation to develop adapted product features. However, design management is not recognised as a strategic collaborative tool in the high tech companies operating in France.

The above-mentioned issues laid the foundation of the following quantitative stage, the aim of which was to gain in-depth knowledge of the situation of the high tech companies operating in France as regards NPD process and the role of design management.



### **5.3. Second quantitative stage**

#### **5.3.1. Introduction**

This section presents the methodology, the questionnaire and describes the results of the second quantitative survey launched among high tech companies operating in France. As mentioned in the results of the exploratory quantitative survey, key factors that emerged from the statistical analysis will eventually be integrated in the final model and lead to further discussion.

#### **5.3.2. Methodology and questionnaire**

##### **5.3.2.1. Methodology**

Developed on the basis of the literature review, the case study and the exploratory survey, the second survey was faxed to 800 randomly selected high tech and medium-high tech companies extracted from the exhaustive list of 3006 firms provided by the French National Institute of Statistics (INSEE<sup>1</sup>). 185 answers were returned, among which 148 were finally exploitable<sup>2</sup>. This means a return rate of 23% which is particularly high when considering the average return rate for unsolicited questionnaires, in France – i.e. about 5% -. In fact, some of the cover letters that were received by the researcher showed that some managers were really interested by the issues raised by the research topic. Like in the first quantitative stage, the final sample respected the proportion of high tech and medium-high tech companies according to the figures provided by the INSEE - i.e. 23% of high tech (34) and 77% of medium-high tech companies (114) -.

At this stage, the objective was to gain precise knowledge of the NPD processes and of the role of design management within high tech and medium-high tech companies. Eventually, this enabled the researcher to determine key-factors impacting the implementation of design management as an integrating function and to build a final model.

---

<sup>1</sup> Institut National de la Statistique et des Etudes Economiques

<sup>2</sup> Level of confidence: 0.90%, e=3%

### **5.3.2.2. Questionnaire**

The questionnaire is presented in appendix 3. The objective was to gain deeper knowledge of the critical issues identified in the previous stage:

- inter-functional links;
- formalism;
- role of top management;
- customer orientation;
- marketing;
- information systems;
- product development priorities;
- design management.

This second questionnaire was much shorter than the exploratory one since the objective was to focus on specific issues. It was mainly centred on the aspects relating to NPD and design management and was composed of four main parts:

- part 1: general presentation of the company
- part 2: project management
- part 3: marketing and the information system
- part 4: design management

The questionnaire was mainly composed of four types of questions (Giannelloni and Vernet, 1994):

- close-ended questions that are adapted to statistical and computer-aided analysis;
- five level scales with opposite adjectives to evaluate opinions;  
ten level scales, used as a typical French academic grading system, to measure factors such as the importance granted to given issues;
- open questions to precise the answers given to close-ended questions when necessary.



### 5.3.3. Results

This section presents the statistical results of the second quantitative survey. When relevant – i.e. when major differences were observed between the high tech + and high tech +/- clusters – the results for each cluster are shown. The statistical analysis is mostly descriptive since the objective was to feed the SSM approach with a diagnosis of the 'real world' situation. It includes uni-variate and bi-variate analyses as well as Khi2 tests in order to measure the level of dependence between given variables.

As regards bi-variate analyses, the tables present the most relevant levels of dependence between variables, with the highest confidence degrees – i.e. superior to 98% -. 'Did not answer' observations were suppressed from the tables presented in order to avoid introducing irrelevant cross-tabulations.

**N.B.: The tables show positive dependencies in bold and bordered whereas negative dependencies are only bordered.**

#### 5.3.3.1. Identity of respondents and general presentation of the companies surveyed

- Respondents' positions in the companies

Like in the first quantitative stage, most respondents were top managers or executives from marketing, production or R&D departments, which implies that they have good knowledge of their organisations and which increases the reliability of the answers given.

- Presentation of the companies surveyed

- *Size of the companies surveyed*

Like in the first quantitative stage, a large proportion of companies – i.e. about 80% - have less than 200 employees, the average being 113 people. However, a difference can be observed

between high tech + and high tech +/- . In fact, the standard deviation for companies with the high tech + group is much higher than for the high tech +/-: respectively 192,45 versus 88,54. Companies in the high tech + cluster cover a larger spectrum than companies from the high tech +/- cluster as regards the number of people employed. This can be explained by a higher number of start-up creations in the sectors concerned by the high tech + cluster – i.e. development and manufacturing of appliances relating to sound, image, broadcast, telecommunications, computing, etc -. Such a spreading may lead to a wider variety of organisational structures and managerial approaches among the high tech companies, especially as regards the way the NPD process is managed. On the contrary, companies within the high tech +/- cluster may show more homogeneity.

- *Companies belonging to a group*

More than half of the companies in the total sample belong to a group. As regards the company, this means that it will benefit from external resources and support but also that some functions, including top management, will often be decentralised. This can impact on certain results relating to organisational issues.

- *APE codes*

The proportion of companies belonging to the clusters high tech + - i.e. high tech companies - and high tech +/- - i.e. medium/high tech companies - respects the national proportion as provided by the INSEE – i.e. respectively 23% and 77% -.

- *Quality certification*

As concerns quality certification, most companies are certified or in the process of being certified – i.e. 83.1% -. However, it can also be outlined that more than 16% of the companies do not have any certification, which is quite an important percentage for a sector in which most products require heavy manufacturing processes and incorporate complex technologies. Concerning the two clusters, the high tech + show an even higher rate of non certified companies – 20.6% versus 14.9% for high tech +/- -. For the two clusters, the large majority of uncertified companies have less

than 100 employees which tends to corroborate the fact that quality certification is usually implemented when organisations are developing. As regards the nature of certifications, most companies are certified by AFAQ (Association Française d'Assurance Qualité) with an ISO 9001 certification.

- Quality certification / number of people employed

**Table 5.15. - Quality certification / number of people employed (total sample)**

Quality cert. Nb. employ.	Yes	In progress	No	TOTAL
Less than 20	3	4	4	11
20 to 50	21	10	8	39
50 to 100	22	8	9	39
100 to 200	29	0	2	31
200 to 400 and more	23	1	1	25
<b>TOTAL</b>	<b>98</b>	<b>23</b>	<b>24</b>	<b>145</b>

1-p: 99.85

Quality certification is directly dependent on the size of the company. Organisations with more than 100 employees are mainly certified whereas smaller organisations – i.e. with less than 50 people – are either in the process of being certified or not certified. As assumed in the first quantitative stage, quality certification may impact on the level of formalisation of NPD since it is based on formalised procedures. Table 5.27. shows the results of cross-tabulations between quality certification and NPD formalism and confirms this assumption.

- *R&D, production and marketing departments*

77% of the companies surveyed have a R&D department, i.e. a formalised R&D function. Among the companies that do not have a R&D department, some have people employed in R&D positions but the department, as such, is not formalised. Others - 12 out of 29 - benefit from the R&D department of the group. As concerns the two clusters of high tech + and high tech +/-, 88.2% of the companies from the former cluster have a R&D department, which is consistent with their heavy technological orientation.



Nearly all the companies – i.e. 93.9% - have a production department, formalised as such. Among the remaining three companies, one has a production department in the group to which it belongs. The number of companies that have a marketing department is around 2/3 of the total sample. However, among the 44 companies that do not have a marketing department, about 1/3 have a marketing department in their groups. A higher percentage of high tech + companies have a marketing department: 76.5% versus 66.2% as regards companies from the high tech +/- sectors.

The questions are that stage are: does the formalisation of the marketing function thanks to a determined department in the company or in the group influence the market orientation, the marketing culture and the NPD process? This will be analysed in section 5.3.3.4.

### 5.3.3.2. Project management

- Collaboration of departments during NPD (multi-disciplinary teams) and interfaces between R&D, production and marketing

**Table 5.16. - Collaboration of several departments during NPD**

Multi-disciplinary teams	Nb. obs.	Freq.
Did not answer	2	1.4%
Never	6	4.1%
Sometimes	25	16.9%
Always	115	77.7%
<b>TOTAL OBS.</b>	<b>148</b>	<b>100.0%</b>

Average = 2.75    Stand. deviation = 0.52  
 1: never; 2: sometimes; 3: always

As shown by the average of 2.75, a large proportion of respondents stated that NPD, in their companies, involves multi-disciplinary teams in which different departments collaborate. This percentage is a little higher for high tech + companies: 82.3%. The question is: does the fact of working with multi-disciplinary teams impact other factors as regards NPD? Table 5.20. will show that it is the case as regards the level of formalism of the exchanges between R&D, production and marketing.

**Table 5.17. - Collaboration of R&D, production and marketing (total sample)**

Collaboration between dpts	Nb. obs.	Freq.
R&D, production and marketing equally collaborate	57	38.5%
More R&D/marketing	42	28.4%
More R&D/production	27	18.2%
More production/marketing	11	7.4%
Did not answer	11	7.4%
<b>TOTAL OBS.</b>	<b>148</b>	<b>100.0%</b>

The most frequent type of collaboration takes place between R&D, production and marketing with 38.5% of answers, followed by R&D/marketing – 28.4% -, R&D/production – 18.2% - and production/marketing – 7.4% -. Collaboration between the three departments is even a little more higher for high tech + companies with 41.2%. However, this collaboration requires further analysis. The next tables show the results relating to the level of formalism of the exchanges as well as the thickness of frontiers between departments.

**Table 5.18. - Level of formalism of exchanges between R&D, production and marketing (total sample)**

Formalism of exchanges	Nb. obs.	Freq.
Did not answer	6	4.1%
Extremely informal	7	4.7%
2	24	16.2%
Medium	52	35.1%
4	44	29.7%
Extremely formal	15	10.1%
<b>TOTAL OBS.</b>	<b>148</b>	<b>100.0%</b>

Average = 3.25 Stand. deviation = 1.02

*1: extremely informal; 2: informal/medium; 3: medium; 4: medium/formal; 5: extremely formal*

1	2	2.5 3	4	5
Extremely informal	2	Medium	4	Extremely formal
			X	

With an average of 3.25 for the total sample, exchanges between departments are tending towards some formalism with no major difference between the two sub-groups.

As regards cross-tabulations, one major dependence was observed between the level of formalism of the exchanges between departments and the formalism of top management control during NPD, as shown in the following table.

**Table 5.19. - Formalism of exchanges between R&D, production and marketing / formalism of top management during NPD (total sample)**

Formal. manag. Formal. exch.	Ext. informal	2	Medium	4	Ext. formal	TOTAL
Ext. informal	1	2	1	1	1	6
2	5	8	5	5	1	24
Medium	0	9	19	23	0	51
4	0	2	9	26	6	43
Ext. formal	0	0	2	6	7	15
<b>TOTAL</b>	<b>6</b>	<b>21</b>	<b>36</b>	<b>61</b>	<b>15</b>	<b>139</b>

1-p: 99.99

Thus, there is significant dependence between the formalism of exchanges and the formalism of top management intervention during NPD. Dependence was also observed between the fact of working with multi-disciplinary teams and the level of formalism of the exchanges between R&D, production and marketing as shown in table 5.20.

**Table 5.20. - Multi-disciplinary teams / formalism of exchanges between R&D, production and marketing (total sample)**

Formal exch. Multi-disc.	Ext. informal/2	Medium	4/ext. formal	TOTAL
Never	1	1	0	2
Sometimes	8	14	3	25
Always	22	37	56	115
<b>TOTAL</b>	<b>31</b>	<b>52</b>	<b>59</b>	<b>142</b>

1-p: 98.91

These figures outline that there is significant dependence between the fact of sometimes working with multi-disciplinary teams and the fact of having a medium level of formalism of the relationships between R&D, production and marketing. The table also shows positive dependence between the fact of always working with multi-disciplinary teams and formal exchanges between the departments. On the contrary, there is negative dependence between 'sometimes' and 'formal', i.e.



few companies that sometimes work with multi-disciplinary teams have formal relationships between R&D, production and marketing -.

Thus, working with multi-disciplinary teams impacts on the formalism of exchanges during NPD.

- Thickness of frontiers between R&D, production and marketing

**Table 5.21. - Thickness of frontiers between R&D, production and marketing (total sample)**

Frontiers	Nb. obs.	Freq.
Did not answer	4	2.7%
Extremely thin	18	12.2%
2	33	22.3%
Medium	49	33.1%
4	38	25.7%
Extremely thick	6	4.1%
<b>TOTAL OBS.</b>	<b>148</b>	<b>100.0%</b>

Average = 2.87 Stand. deviation = 1.07

1	2	2.5 3	4	5
Extremely thin	2	Medium X	4	Extremely thick

In the total sample, frontiers between R&D, production and marketing are considered to be, on average, a little higher than 'medium', i.e. slightly tending towards some thickness. This result corroborates the data concerning the level of formalism of exchanges shown in table 5.18.

- *Thickness of frontiers / number of people employed*

**Table 5.22. - Thickness of frontiers between R&D, production and marketing / number of people employed (total sample)**

Frontiers \ Nb. employ.	Ext. thin	2	Medium	4	Ext. thick	TOTAL
Less than 20	4	3	1	2	0	10
20 to 50	7	12	9	10	0	38
50 to 100	4	7	13	12	2	38
100 to 200	0	11	13	5	1	30
200 to 400	2	0	10	7	3	22
400 and more	0	0	3	1	0	4
<b>TOTAL</b>	<b>17</b>	<b>33</b>	<b>49</b>	<b>37</b>	<b>6</b>	<b>142</b>

The size of the company and the thickness of the frontiers between R&D, production and marketing are dependent variables. Smaller companies tend to have extremely thin frontiers whereas organisations with 200 to 400 people tend to have thicker frontiers. In fact, in small size businesses, departments are rarely very formalised and relationships are generally favoured by geographical proximity. On the contrary, larger organisations usually have formalised departments which make relationships more formal.

At that stage, the assumption could be that the larger the company, the more formal the exchanges. However, cross-tabulations between the size of the company and the formalism of exchanges and formalism of NPD processes surprisingly do not show any dependence. Thus, frontiers are perceived as being either thin, in the case of smaller companies, or thick, in the case of large organisations, but there is no direct link with the degree of formalism of exchanges and NPD processes.

In fact, due to their sizes, very large organisations have had to formalise their departments, which are perceived as being separated by thick frontiers, but they also may have implemented specific methods that favour collaborations between functions – e.g. multi-disciplinary teams -.

- Level of participation of R&D, production and marketing in the NPD process

**Table 5.23. - Equal participation of R&D, production and marketing in NPD (total sample)**

Participation in NPD	Nb. obs.	Freq.
Did not answer	4	2.7%
Not at all	28	18.9%
Medium	54	36.5%
Absolutely	62	41.9%
<b>TOTAL OBS.</b>	<b>148</b>	<b>100.0%</b>

Average = 2.24 Stand. deviation = 0.76

1	1.5 2	3
Not at all	Medium	Absolutely
		X

On average, the participation of R&D, production and marketing is above average, tending towards an equal contribution of each department. As regards companies from the high tech + group, 50% consider that the three departments equally contribute to the NPD process – versus about 40% for

companies from the high tech +/- group -. Consequently, it appears that, even though the companies surveyed tend to perceive some formalism in their internal collaborations, R&D, production and marketing tend to equally participate in the NPD process. In fact, it seems that even though cross-functional exchanges do not take place 'naturally', multi-disciplinary teamwork and the way NPD is managed favour the involvement of all the functions in the NPD process.

- Level of formalism of the NPD process

**Table 5.24. - Level of formalism of the NPD process (total sample)**

Formalism of NPD	Nb. obs.	Freq.
Did not answer	4	2.7%
Extremely informal	9	6.1%
2	20	13.5%
Medium	44	29.7%
4	48	32.4%
Extremely formal	23	15.5%
<b>TOTAL OBS.</b>	<b>148</b>	<b>100.0%</b>

Average = 3.39 Stand. deviation = 1.10

	1	2	2.5 3	4	5
Extremely informal		2	Medium	4	Extremely formal

On average, NPD is quite formal for the total sample. This tends to confirm that in a context of formal NPD, functions are 'pushed' to work together. This corroborates the findings presented in table 5.20. - i.e. working with multi-disciplinary teams increases the formalism of exchanges -. In a global context of formal processes and relationships, companies have implemented organisational and/or managerial factors that tend to reduce the space between departments.

Cross-tabulations between NPD formalism and the fact of belonging or not to a group are shown in the following table:

**Table 5.25. - Formalism NPD / belong or not to a group (total sample)**

Formal. NPD / Group	Ext. informal	2	Medium	4	Ext. formal	TOTAL
Yes	1	11	19	31	16	78
No	8	9	25	17	7	66
<b>TOTAL</b>	<b>9</b>	<b>20</b>	<b>44</b>	<b>48</b>	<b>23</b>	<b>144</b>

1-p: 98.95



The results presented in table 5.25. show that there is significant dependence between the fact of not belonging to a group and the fact of having 'extremely informal'/medium' NPD. Negative dependencies also appear between companies that belong to a group and extremely informal NPD as well as between companies that do not belong to a group and extremely formal NPD.

**Thus, the fact of being an independent company, not linked to a larger organisation, tends to lead to more informal NPD processes.**

The following table shows cross-tabulations between NPD formalism and the existence, or not, of a marketing department in the company.

- *Formalism of NPD / marketing department in the company*

**Table 5.26. - Formalism of NPD / marketing department in the company**

Form. NPD \ Mark. dpt	Ext. informal	2	Medium	4	Ext. formal	TOTAL
Yes	2	10	30	37	19	98
No	7	8	14	8	3	40
<b>TOTAL</b>	<b>9</b>	<b>18</b>	<b>44</b>	<b>45</b>	<b>22</b>	<b>138</b>

1-p: 99.87

There is a strong dependence between the fact of having a marketing department in the company and the level of formalism of the NPD process. First, when there is no marketing department in the company, NPD is mostly 'extremely formal'. On the opposite, there is a negative contribution as regards formality – i.e. few companies with no marketing department have formal NPD processes -. When there is a marketing department in the company, there is a negative contribution concerning the level of informality – i.e. few companies that have a marketing department have informal processes -.

**Thus, the existence of a marketing department in the companies surveyed impact on the level of formalism of the NPD processes.** This means that the marketing department helps formalising the NPD process. In fact, this confirms the observations made at Wandel & Goltermann where the marketing department was the main co-ordinator of NPD.

- *NPD formalism / quality certification*

**Table 5.27. - Quality certification / NPD formalism (total sample)**

Quality cert. \ Formal. NPD	Yes	In progress	No	TOTAL
Ext. informal	4	3	2	9
2	12	5	3	20
Medium	20	9	15	44
4	39	5	4	48
Ext. formal	21	1	0	22
<b>TOTAL</b>	<b>96</b>	<b>23</b>	<b>24</b>	<b>143</b>

1-p: 99.85

Most of the companies which have extremely formal NPD processes have quality certifications. This is confirmed by the negative dependence that exists between the companies that are not certified and the formalism of their NPD processes. These companies have mostly an average level of formalism – i.e. ‘medium’ – whereas there is a negative dependence for the certified companies.

Consequently, quality certification increases the level of formalism of NPD, the rationale underpinning this result being that certified companies have to respect heavy procedures.

- *Control from top management during NPD*

**Table 5.28. - Control from top management during NPD (total sample)**

Formal management	Nb. obs.	Freq.
Did not answer	5	3.4%
Extremely informal	6	4.1%
2	21	14.2%
Medium	39	26.4%
4	62	41.9%
Extremely formal	15	10.1%
<b>TOTAL OBS.</b>	<b>148</b>	<b>100.0%</b>

Average = 3.41 Stand. deviation = 1.00

	1	2	2.5 3	4	5
Extremely informal		.2	Medium	4	Extremely formal
				×	

Globally, the control of top management during the NPD process is perceived as tending towards some formalism. The two groups of high tech + and high tech +/- did not show any major difference. The role of managers in NPD processes tend to increase the level formalism. However, these results were cross-checked with the size of the company so as to see whether or not the role of managers tend to be the same in small businesses and in larger organisations. As well, cross-tabulations were calculated so as to see whether formalism of management is influenced by the fact of belonging, or not, to a group. None of these two tests proved to be significant.

However, when considering the information collected in the literature review, heavy control from top management has a negative impact on different issues such as time-to-market and a design-friendly atmosphere (Walker, 1993; Smith and Reinersten, 1991). This will be integrated in the final analysis.

### 5.3.3.3. Information system and marketing

- Environmental scanning and customers' feedback

**Table 5.29. - Environmental scanning (total sample)**

Env. scanning	Nb. obs.	Freq.
Did not answer	1	0.7%
Non-existent/1	4	2.7%
2/3	25	16.9%
4/medium/6	61	41.2%
7/8	50	33.8%
9/excellent	7	4.7%
<b>TOTAL OBS.</b>	<b>148</b>	<b>100.0%</b>

Average = 6.57 Stand. deviation = 2.13

The scale was initially graded from 'non-existent' to 'excellent' with 10 possible marks. These grades are grouped in the table above for easiness of analysis.

0	1	2	3	4	5	6	7	8	9	10
Non-existent/1		2/3		4/medium/6			7/8		9/excellent	
							X			

For the total sample, environmental scanning is above average, even though when considering the degree of uncertainty of the high tech environment (see section 2.4.2.8.), an average mark of 6.57



does not demonstrate high consciousness of external threats. However, the standard deviation of 2.13 outlines that there was a large disparity of answers to this question. Moreover, within the total sample, the two clusters show important differences as presented in tables 5.30. and 5.31.

**Table 5.30. - Environmental scanning (high tech +)**

Env. scanning	Nb. obs.	Freq.
Non-existent/1	0	0.0%
2/3	2	5.9%
4/medium/6	18	52.9%
7/8	12	35.3%
9/excellent	2	5.9%
<b>TOTAL OBS.</b>	<b>34</b>	<b>100.0%</b>

**Average = 7.15    Stand. deviation = 1.74**

In the cluster high tech +, no company have non-existent environmental scanning and the average is higher than for the total sample. Moreover, the standard deviation of 1.74 shows more homogeneity as regards the answers given by this group. In fact, companies with heavier technological inputs tend to be more conscious of the uncertainty of their external environments. This is confirmed by the data relating to the high tech +/- cluster which are presented below:

**Table 5.31. - Environmental scanning (high tech +/-)**

Env. scanning	Nb. obs.	Freq.
Did not answer	1	0.9%
Non-existent/1	4	3.5%
2/3	23	20.2%
4/medium/6	43	37.7%
7/8	38	33.3%
9/excellent	5	4.4%
<b>TOTAL OBS.</b>	<b>114</b>	<b>100.0%</b>

**Average = 6.40    Stand. deviation = 2.21**

Companies from the group high tech +/- show a larger disparity of answers. Moreover, a larger percentage than high tech + have little environmental scanning: 23.7% have ranked this function between 'non-existent' and '2/3' whereas this percentage is 5.9% for the other group. Next tables will show the results relating to customers' feedback.

**Table 5.32. - Customers' feedback (total sample)**

Cust. feedback	Nb. obs.	Freq.
Did not answer	1	0.7%
Non-existent/1	0	0.0%
2/3	15	10.1%
4/medium/6	37	25.0%
7/8	81	54.7%
9/excellent	14	9.4%
<b>TOTAL OBS.</b>	<b>148</b>	<b>100.0%</b>

Average = 7.60 Stand. deviation = 1.85

0	1	2	3	4	5	6	7	8	9	10
Non-existent/1		2/3		4/medium/6			7/8		9/excellent	

Customers' feedback is globally quite good, with an average mark of 7.60 out of 10. As shown in following table, it is even higher for high tech + companies.

**Table 5.33. - Customers' feedback (high tech +)**

Cust. feedback	Nb. obs.	Freq.
Non-existent/1	0	0.0%
2/3	0	0.0%
4/medium/6	7	20.6%
7/8	23	67.6%
9/excellent	4	11.8%
<b>TOTAL OBS.</b>	<b>34</b>	<b>100.0%</b>

Average = 8.24 Stand. deviation = 1.21

With an average of 8.24, high tech + companies show important customer orientation. Moreover, the standard deviation outlines that answers were quite homogeneous. In fact, no respondent gave a mark inferior to 4.

When considering the fact that environmental scanning and customers' feedback are both concerning the companies' information systems, it can be assumed that these two variables will show significant dependence. Results of these cross-tabulations are presented in the following table.

**Table 5.34. - Environmental scanning / customers' feedback (total sample)**

Env. scanning Cust. feedb.	Non existent/3	4/medium/6	7/excellent	TOTAL
2/3	11	3	1	15
4/medium/6	8	17	12	37
7/excellent	10	41	44	95
<b>TOTAL</b>	<b>29</b>	<b>61</b>	<b>57</b>	<b>147</b>

1-p: 99.22

There is significant dependence between the fact of having weak customers' feedback and the fact of having weak environmental scanning.

Next table shows the results relating to strong environmental scanning and the existence, or not of a marketing department.

- *Environmental scanning / marketing department*

**Table 5.35. - Environmental scanning / marketing department**

Env. scanning Marketing dpt	Non existent/3	4/medium /6	7/excellent	TOTAL
Yes	11	47	40	98
No	16	13	14	43
<b>TOTAL</b>	<b>27</b>	<b>60</b>	<b>54</b>	<b>141</b>

1-p: 99.87

There is a strong dependence between the fact of having a marketing department in the company and the level of environmental scanning. Most companies that have a marketing department do not have weak environmental scanning whereas companies that do not have marketing departments often have weak environmental scanning. However, cross-tabulations showed that there is no significant dependence with the level of customers' feedback.

**Thus, the existence of a marketing department impacts on the level of environmental scanning.**



• Formalism of market follow-up

**Table 5.36. – Formalism of market follow up (total sample)**

Market follow up	Nb. obs.	Freq.
Ext. informal	10	6,8%
2	44	29,7%
Medium	62	41,9%
4	30	20,3%
Ext. formal	1	0,7%
<b>TOTAL OBS.</b>	<b>148</b>	

**Average: 2.78    Stand. Deviation: 0.87**

	1	2	2.5 3	4	5
<b>Extremely informal</b>		2	Medium	4	<b>Extremely formal</b>
			X		

As regards the total sample, the average is just above 2.5. Again, this stresses important weaknesses as regards the information system. There is no major difference between high tech + and high tech +/-.

*Formalism of market follow-up / feedback from customers*

**Table 5.37. - Formalism of market follow-up / feedback from customers**

Mark. follow-up \ Cust. feedback	Ext. informal/2	Medium	4/ext. formal	TOTAL
Non-existent/3	9	5	1	15
4/medium/6	17	18	2	37
7/excellent	28	39	28	95
<b>TOTAL</b>	<b>54</b>	<b>62</b>	<b>31</b>	<b>147</b>

1-p: 99.29

There is heavy dependence between the formalism of market follow-up and customers' feedback. In the companies in which market follow-up is informal, customers' feedback is weak. On the other hand, in the companies where market follow-up is formal, customers' feedback is strong. Consequently, the level of customers' feedback and formalism of market follow-up are dependent.

### 5.3.3.4. Importance of marketing culture

**Table 5.38. - Importance of marketing culture (total sample)**

Marketing culture	Nb. obs.	Freq.
Did not answer	3	2.0%
Non-existent/1	8	5.4%
2/3	38	25.7%
4/medium/6	61	41.2%
7/8	31	20.9%
9/extremely strong	7	4.7%
<b>TOTAL OBS.</b>	<b>148</b>	<b>100.0%</b>

Average = 5.91    Stand. Deviation = 2.23

0	1	2	3	4	5	6	7	8	9	10
Non-existent/1		2/3		4/medium/6			7/8		9/	ext. strong
						X				

Globally, the importance of the marketing culture is just above average, which does not show a strong marketing orientation. When considering the literature as regards marketing in high tech sectors, this is not very surprising. However, when looking at the average for the high tech + companies, it appears that, with a mark of 7 out of 10, their average is much higher than for the total sample. Standard deviation is also more reduced – 1.74 -. Thus, companies with heavy technological activities are more concerned by marketing than the ones with lower technological intensity. In fact, this supports the previous results that showed stronger environmental scanning and customer feedback in the companies with the highest levels of technological intensity. Further investigation would be required concerning this issues – see discussion in chapter 6 -.

- *Marketing culture / marketing department*

**Table 5.39. - Marketing culture / marketing department**

Market. culture \ Marketing dpt	Non existent/3	4/medium/6	7/extremely strong	TOTAL
Yes	22	41	33	96
No	23	16	4	43
<b>TOTAL</b>	<b>45</b>	<b>57</b>	<b>37</b>	<b>139</b>

1-p: 99.96

There is a strong dependence between the existence of a marketing department and the importance of the marketing culture in the organisation. Companies that do not have a marketing department have weak marketing cultures. Moreover, there is a negative dependence between the fact of not having a marketing department and a high importance of the marketing culture – i.e., most companies that do not have a marketing department do not have a strong marketing culture -.

- *Marketing culture / feedback from customers*

**Table 5.40. - Marketing culture / feedback from customers**

<b>Mark. culture</b> <b>Cust. feedback</b>	<b>Non existent/3</b>	<b>4/medium/6</b>	<b>7/ext. strong</b>	<b>TOTAL</b>
<b>Non-existent/3</b>	<b>11</b>	<b>3</b>	<b>0</b>	<b>14</b>
<b>4/medium/6</b>	<b>15</b>	<b>16</b>	<b>6</b>	<b>37</b>
<b>7/excellente</b>	<b>20</b>	<b>42</b>	<b>32</b>	<b>94</b>
<b>TOTAL</b>	<b>46</b>	<b>61</b>	<b>38</b>	<b>145</b>

1-p: 99.98

There is strong dependence between the level of customers' feedback and the level of marketing culture. When feedback from customers is weak, marketing culture is weak. As regards negative contribution, when marketing culture is weak, feedback from customers is rarely strong. When marketing culture is high, feedback from customers is rarely weak.

Thus, the existence of a marketing department positively impacts on customer feedback.

- Commercial and advertising efforts

**Table 5.41. - Commercial and advertising efforts (total sample)**

<b>Com. and adv. efforts</b>	<b>Nb. obs.</b>	<b>Freq.</b>
<b>Did not answer</b>	<b>2</b>	<b>1.4%</b>
<b>Non-existent/1</b>	<b>3</b>	<b>2.0%</b>
<b>2/3</b>	<b>20</b>	<b>13.5%</b>
<b>4/medium/5</b>	<b>60</b>	<b>40.4%</b>
<b>7/8</b>	<b>51</b>	<b>34.4%</b>
<b>9/extremely strong</b>	<b>12</b>	<b>8.2%</b>
<b>TOTAL OBS.</b>	<b>148</b>	<b>100.0%</b>

Average = 6.75 Standard deviation = 2.06

<b>0</b>	<b>1</b>	<b>2</b>	<b>3</b>	<b>4</b>	<b>5</b>	<b>6</b>	<b>7</b>	<b>8</b>	<b>9</b>	<b>10</b>
<b>Non-existent/1</b>		<b>2/3</b>		<b>4/medium/6</b>			<b>7/8</b>			<b>9/ ext. strong</b>



For the total sample, the commercial and advertising efforts are globally above average. This outlines that marketing strategies in the high tech sectors tends to be “push”, rather than “pull” – i.e. commercial and advertising tools are used to convince customers about products advantages -. The fact that high tech products are generally pushed during stages 3 and 4 of product development was outlined by Bouvard (1998).

Moreover, the two clusters of high tech + and high tech +/- show differences as regards their commercial and advertising efforts. The average mark for high tech + companies is higher than for high tech +/- with respectively 6.85 and 5.58. This confirms that companies with the highest levels of technological intensity are more aggressive in their commercial strategies.

#### 5.3.3.5. Design management

- Design function in the organisation or group and subordination to another department

**Table 5.42. - Design function in the company (total sample)**

Design function	Nb. obs.	Freq.
Did not answer	2	1.4%
Yes	34	23.0%
No	112	75.7%
<b>TOTAL OBS.</b>	<b>148</b>	<b>100.0%</b>

About ¼ of the companies surveyed have a design function – i.e. an entity in charge of design, which may not be formalised by the existence of a determined department -. Whereas this percentage is around 20% for high tech +/- companies, it reaches a little more that 32% for high tech +. Companies that have a design function will require further analysis in order to measure the impact of such a function on the rest of the organisation and especially as regards NPD. Concerning the existence of a design function in the group, the results were the following:

**Table 5.43. - Design function in the group (for companies that belong to a group)**

*Note that 54.7% of the companies surveyed belong to a group*

Design function in group	Nb. obs.	Freq.
Did not answer	11	10.6%
Yes	31	29.8%
No	62	59.6%
<b>TOTAL OBS.</b>	<b>104</b>	<b>100.0%</b>

About 30% of the companies that belong to a group benefit from a design function. So, about 44% of the companies from the total sample have a design function, either internally or in the group to which they belong.

Tables 5.44. and 5.45. show the answers that were given as regards the subordination of the design function.

**Table 5.44. - Subordination of design to another department**

Subordination of design	Nb. obs.	Freq.
Did not answer	95	64.2%
Design is subordinated to another department	37	25.0%
Design is an independent department	10	6.8%
Do not know	6	4.1%
<b>TOTAL OBS.</b>	<b>148</b>	<b>100.0%</b>

When there is a design function, it is generally subordinated to another department for a large majority of companies. This is in opposition with what was stressed in the literature review concerning efficient design strategies – i.e. it requires an independent design function –. In fact, only 6.8% of the companies surveyed have an actual design department. Table 5.45. shows the answers that were given as regards the departments to which design is generally subordinated:

**Table 5.45. - Departments to which design is subordinated (total sample)**

Which dpt	Nb. obs.	Freq.
Did not answer	112	75,7%
R&D	15	10,1%
Marketing	7	4,7%
Production	3	2,0%
Other: technical	9	6,1%
<b>TOTAL OBS.</b>	<b>148</b>	

Globally, the design function, when being subordinated to another department, mainly depends on R&D, followed by production and marketing. Thus, it is mainly attached to technical functions, which may threaten the development of a market-oriented approach. This emphasises the necessity of efficient collaborations between these technical functions and the marketing department.

- Work with external designers

**Table 5.46. - Work with external designers (total sample)**

External designers	Nb. obs.	Freq.
Did not answer	6	4.1%
Never	61	41.2%
Sometimes	66	44.6%
Always	12	8.1%
Do not know	3	2.0%
<b>TOTAL OBS.</b>	<b>148</b>	<b>100.0%</b>

The number of companies working with external design consultants globally reaches about 52%. However, it is usually on an occasional basis. Companies in the high tech + and high tech +/- groups show some difference as regards occasional and systematic work with external designers. In the high tech + group, this percentage is around 55% whereas it is around 40% for the other group. When considering the answers given to question 18 – i.e. is there a design function in the company? -, it appears that high tech + companies are more design-oriented than in the other group.

- Importance of design management in companies and role in the NPD process

**Table 5.47. - Importance granted to design in companies (total sample)**

Design in companies	Nb. obs.	Freq.
Did not answer	8	5.4%
Non-existent/3	60	40.5%
4/medium/6	33	22.3%
7/excellent	47	31.8%
<b>TOTAL OBS.</b>	<b>148</b>	<b>100.0%</b>

Average = 5.59 Stand. deviation = 2.74

0	1	2	3	4	5	6	7	8	9	10
Non-existent/1		2/3		4/medium/6			7/8		9/excellent	



With an average of 5.59 out of 10, the importance granted to design in the companies surveyed is not very high. However, the two groups, high tech + and high tech +/-, show some disparity in their answers. As illustrated by tables 5.48. and 5.49. the importance granted to design by high tech + companies is higher than for high tech +/- companies. Table 5.50. shows how the role of design to favour collaborations between R&D, marketing and production is perceived.

**Table 5.48. - Importance granted to design (high tech +)**

Design in companies	Nb. obs.	Freq.
Non-existent/3	10	29.4%
4/medium/6	11	32.4%
7/extremely high	13	38.2%
<b>TOTAL OBS.</b>	<b>34</b>	<b>100.0%</b>

Average = 6.38 Stand. deviation = 2.36

0	1	2	3	4	5	6	7	8	9	10
Non-existent/1		2/3		4/medium/6			7/8		9/excellent	

**Table 5.49. - Importance granted to design (high tech +/-)**

Design in companies	Nb. cit.	Fréq.
Did not answer	8	7.0%
Non-existent/3	50	43.9%
4/medium/6	22	19.3%
7/excellent	34	29.8%
<b>TOTAL OBS.</b>	<b>114</b>	<b>100.0%</b>

Average = 5.34 Stand. deviation = 2.81

0	1	2	3	4	5	6	7	8	9	10
Non-existent/1		2/3		4/medium/6			7/8		9/excellent	

**Table 5.50. - Role of design management to develop collaborations between R&D, production and marketing (total sample)**

Design and collaborations	Nb. obs.	Freq.
Did not answer	21	14.2%
Ineffective/3	59	39.9%
4/medium/6	36	24.3%
7/extremely efficient	32	21.6%
<b>TOTAL OBS.</b>	<b>148</b>	<b>100.0%</b>

Average = 5.15 Stand. deviation = 2.65

0	1	2	3	4	5	6	7	8	9	10
Ineffective/ 1		2/3		4/medium/6			7/8		9/ ex. efficient	
					✘					

On average, design management is not perceived as strongly favouring collaborations between R&D, production and marketing. However, answers from the two groups showed differences.

**Table 5.51. - Role of design management to develop collaborations between R&D, production and marketing (high tech +)**

Design and collaborations	Nb. obs.	Freq.
Did not answer	3	8.8%
Ineffective/3	10	29.4%
4/medium/6	12	35.3%
7/extremely efficient	9	26.5%
<b>TOTAL OBS.</b>	<b>34</b>	<b>100.0%</b>

Average = 5.81 Stand. deviation = 2.73

0	1	2	3	4	5	6	7	8	9	10
Ineffective/ 1		2/3		4/medium/6			7/8		9/ ex. efficient	
					✘					

**Table 5.52. - Role of design management to develop collaborations between R&D, production and marketing (high tech +/-)**

Design and collaborations	Nb. obs.	Freq.
Did not answer	18	15.8%
Inefficient/3	49	43.0%
4/medium/6	24	21.1%
7/extremely efficient	23	20.2%
<b>TOTAL OBS.</b>	<b>114</b>	<b>100.0%</b>

Average = 4.94 Stand. deviation = 2.60

0	1	2	3	4	5	6	7	8	9	10
Ineffective/ 1		2/3		4/medium/6			7/8		9/ ex. efficient	
					✘					

Even though the averages for these two groups do not emphasise a strong role of design management in favouring collaborations between R&D, production and marketing, high tech + companies tend to be more design-oriented.

**Table 5.53. - Design to favour collaborations between R&D, production and marketing / belong or not to a group (total sample)**

Design/collab. Group	Inefficient /1	2/3	4/5/6	7/8	9/ext. efficient	TOTAL
Yes	16	26	19	12	0	73
No	5	12	17	16	4	54
<b>TOTAL</b>	<b>21</b>	<b>38</b>	<b>36</b>	<b>28</b>	<b>4</b>	<b>127</b>

1-p: 98.90

Table 5.53. - shows that there is significant dependence between the fact of not belonging to a group and the fact of considering that design management is efficient to favour collaborations between R&D, production and marketing. Negative dependence can also be observed: few companies that do not belong to a group consider that design is inefficient and few companies that belong to a group consider that it is very efficient.

Thus, there is dependence between the fact of belonging or not to a group and the perception of design as favouring collaborations between departments.

Although it was previously mentioned that high tech + and high tech +/- companies showed differences concerning their perceptions of design management as a collaborative tool, the two groups were globally homogeneous as regards the role of design management in high tech organisations – see table 5.54. -.

**Table 5.54. - Role of design in high tech companies, in general (total sample)**

Design in high tech	Nb. obs.	Freq.
Did not answer	17	11.5%
Not important at all/3	16	10.8%
4/medium/6	30	20.3%
7/extremely important	85	57.4%
<b>TOTAL OBS.</b>	<b>148</b>	<b>100.0%</b>

Average = 7.53 Stand. deviation = 2.34

0	1	2	3	4	5	6	7	8	9	10
Not important at all/1		2/3		4/medium/6			7/8		9/ ex. important	
							x			



The role of design in high tech organisations is, on average, considered as being important. This is a central point when considering 'the situation to be reached' in the SSM process. In fact, even though the importance granted to design in most of the organisations surveyed is medium, managers consider that it has a role to play in their sectors. This supports the research objectives, the aim of which is to analyse the actions to be taken so as to increase the role of design management in high tech companies.

At this stage, it comes into view that even though, on average, design is not actually a priority in high tech organisations, they are conscious that its role is important in high tech sectors. Thus, there appears to be a gap between practices and the perception companies have of the importance design management should have in their sectors of activity.

Table 5.55. shows the results of the cross-tabulations between the importance granted to design management and quality certification.

**Table 5.55. - Importance of design management / quality certification**

Imp. of design Quality cert.	Non existent/3	4/medium/6	7/ext. strong	TOTAL
Yes	46	19	28	93
In progress	6	11	7	24
No	8	2	12	22
<b>TOTAL</b>	<b>60</b>	<b>32</b>	<b>47</b>	<b>139</b>

1-p: 99.20

There is strong dependence between the importance granted to design management and quality certification. Companies which are not certified consider that the importance of design management is strong in their organisations whereas companies which are certified consider that design management is weak. In fact, companies that are certified are more formal in their processes and, as stressed in the literature review, the development of a design-oriented culture is easier in informal environments (Walker, 1993).

**Consequently, quality certification is detrimental to the importance granted to design management.**

When taking into account the fact that there is strong dependence between the size of the companies surveyed and quality certification, it can be considered that the size of the company would influence the importance granted to design. However, it appears when looking at cross-tabulations that the dependence is not significant between these two variables.

However, as shown in table 5.56., strong dependence was found between the importance granted to design and the existence of a design function in the company.

**Table 5.56. - Importance of design / design function in the company**

Design in cy \ Design function	Design function		TOTAL
	Yes	No	
Non existent/3	5	54	59
4/medium/5	4	29	33
7/extremely strong	25	22	47
<b>TOTAL</b>	<b>34</b>	<b>105</b>	<b>139</b>

1-p: 99.61

There is significant dependence between the importance granted to design and the fact of having a design function in the company. In fact, companies with a design function grant more importance to design than the companies that do not have a design function. This must be integrated in later analysis since it appears that the implementation of a design function will act as a catalyst for the design orientation, thus creating a virtuous cycle.

**Table 5.57. - Importance of design / design to favour collaborations**

Design in cy \ Design collaboration	Design collaboration			TOTAL
	Inefficient/3	4/medium/6	7/extremely efficient	
Non existent/3	40	3	4	47
4/medium/6	8	19	5	32
7/extremely strong	10	14	23	47
<b>TOTAL</b>	<b>58</b>	<b>36</b>	<b>32</b>	<b>126</b>

1-p: 99.99

There is strong dependence between the importance granted to design in the company and the perception of design to favour collaborations. Thus, when design is valued in the corporate

**culture, it positively impacts on inter-functional relationships.** Again, this will have to be integrated in the final analysis since cross-functional collaborations was identified as a main issue for the high tech companies.

#### **5.3.4. Synthesis of findings and general conclusions**

The following key-factors emerged from the second quantitative stage:

- **NPD:**

- Most companies already have cross-functional collaborations.
- Multi-disciplinary teams lead to more formal exchanges.
- Exchanges tend to be formal.
- Formalism of top management is linked to formalism of exchanges.
- Quality certification is linked to strong NPD formalism.

- **Marketing:**

- The existence of a marketing department leads to more formal NPD.
- The marketing department helps formalising environmental scanning and market follow-up.
- Marketing culture is stronger in companies with a marketing department.

- **Management:**

- Control of top management during NPD is quite formal.
- Formal management is linked to strong formalism of NPD.

- **Design:**

- For most of the companies, design is not a priority and is granted moderate importance.
- One quarter of the companies surveyed have a design function.
- 6.8% have an independent design department.
- Design is rarely independent and most of the time subordinated to other functions.
- There is more importance granted to design in companies where there is a design function.
- Design management is not considered as being particularly efficient to increase collaborations, except in the companies that grant much importance to design and in companies with a design function.



- Companies consider that, from a general point of view, design is important for high tech organisations.
- Certified companies grant less importance to design.

Consequently, different key-factors relating to NPD and to design management in the high tech companies operating in France have emerged from this second quantitative survey.

First, the survey confirmed that NPD processes are mainly formal and that this formalism is increased by different factors including: multi-disciplinary teams, formalism from top management, existence of a marketing department and quality certification. Globally, cross-functional relationships are mostly 'pushed' by external factors and do not take place 'naturally'. Thus, there are still important cultural resistances to multi-disciplinary collaborations.

Second, as regards marketing, the results revealed that the existence of a marketing department leads to better environmental scanning and to a higher marketing culture. It also increases the level of formalism during NPD which confirms the observations made at Wandel and Goltermann where the marketing department was heavily guiding the NPD process.

Third, concerning design management, it appeared that whereas companies consider that it has a role to play in high tech organisations, design is practically granted little consideration. In fact, only 6.8% of the companies surveyed have an independent design department. Most of the time, design is subordinated to other departments. However, in organisations where there is a design function, the design culture is higher and it is considered to favour cross-functional collaborations. Another important point that emerged concerning the importance of design management is that it is negatively impacted by quality certifications. The formal NPD context generated by quality procedures is, thus, detrimental to the design orientation.

The findings from both the exploratory survey and the second quantitative stage are synthesised in fig. 5.1. These findings will then be integrated in the final model and lead to further discussion.



Fig. 5.1. - Synthesis of findings from quantitative stages

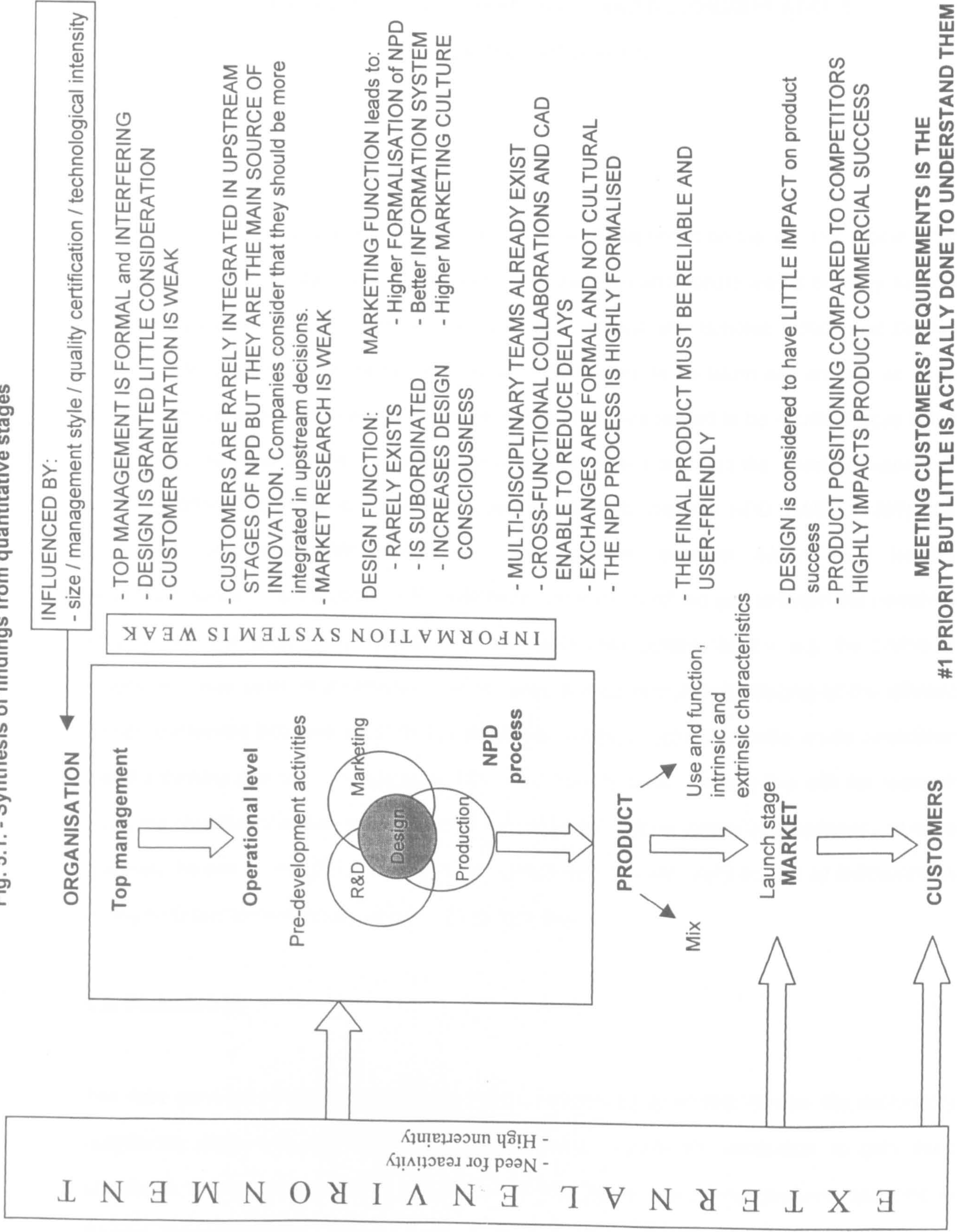



## **CHAPTER 6: MODEL, DISCUSSION, LIMITS AND RECOMMENDATIONS FOR FURTHER RESEARCH**

### **6.1. Introduction**

The final model is founded on soft systems methodology (SSM) based on the arguments presented in the methodology chapter. SSM was considered as the most appropriate way of building the final model for different reasons. First, as stressed by Checkland and Scholes (1990) and Bentley (1993), SSM fully integrates the fact that human factors have to be taken into account so as to adopt measures in accordance with corporate culture. This was judged to be a critical issue in the field of organisational change. Second, since researchers have criticised the 'check-list approach' used by different authors to provide 'recipes' in order to improve NPD (Millier, 1997), the assumption was that SSM would help providing both practical actions and feasible recommendations – i.e. the steps to be implemented in order to fill the gap between the perceived situation and the state to be reached -. Third, the process guiding SSM – e.g. the CATWOE mnemonic - was seen as an efficient way of taking into account and structuring all the different parties and factors that have a role to play in the transformation process. Finally, it was considered that the thinking approach underpinning SSM – e.g. 'rich pictures' – was in line with the research topic, the objective of which is to emphasise the integrating role of design management and more precisely the part it can play in high tech organisations to develop cross-functional collaborations during NPD and to better meet customers' requirements.

### **6.2. Methodology**

The data gathered through the literature review, the case study of WG France, the exploratory quantitative stage and the second quantitative stage enabled the researcher to gain deep knowledge of the actual situation relating to NPD in the high tech organisations operating in France. This information was then compared to the state to be reached so as to improve the efficiency of NPD through the implementation of design management.



Based on the root definition and the CATWOE mnemonic presented in the chapter dedicated to the methodology, the purpose of the model is to help in implementing a corporate strategy and organisation that value the role of design management in the NPD process of the high tech companies operating in France. In accordance with the principles of SSM, the building of the final model was based on the following steps:

- rich picture;
  - diagnosis of current situation;
  - presentation of the situation to be reached;
  - 'root definition';
  - CATWOE mnemonic;
  - analysis of the factors that will influence the situation;
  - recommendations relating to the measures to be taken so as to fill the gap between the perceived situation and the situation to be reached.
- } Transformation process

### 6.3. Diagnosis of current situation

The diagnosis of the current situation as regards NPD in the high tech organisations operating in France is based on the data collected in the two quantitative surveys. The key elements that emerged from these stages were presented in fig. 5.1., p. 193. It was observed that:

- meeting customers' requirements is the number one priority;
- however, market research is generally weak and is granted reduced resources;
- information systems also have to be improved;
- most companies are marketing-oriented but not market-oriented.
- customers are rarely integrated in multidisciplinary teams;

⇒ **Companies are aware that they must meet customers' needs but, in reality, there is little customer focus.**

⇒ **Top management exercises formal control and is heavily interfering in the NPD process.**

- the design function only exists in about ¼ of the companies surveyed and is generally subordinated to another department;
- even though companies consider that the product must be reliable and user-friendly, design is considered to have little impact on product success;

⇒ **Design management is granted little consideration.**

- the existence of a marketing department increases the formalisation of the NPD process;
- however, it also leads to better information systems and to a higher marketing culture.

⇒ **The marketing department has a decisive role to play in terms of market research and marketing strategy.**

- multidisciplinary teams already exist in many companies but cross-functional exchanges are mostly formalised and frontiers still exist between departments.

⇒ **Cross-functional exchanges are mostly formal as distinct from cultural.**

⇒ **NPD processes are, in a large majority, totally or partially formalised.**

Table 6.1. synthesises the observations that have lead to the definition of the 'inputs' to be integrated in the SSM model.

**Table 6.1. - 'Input' of the SSM model**

Observations	'Input' of the SSM model
<ul style="list-style-type: none"> <li>- Multidisciplinary team project management, mostly formalised.</li> <li>- Focus on R&amp;D/marketing links but production must be integrated in the upstream stages.</li> </ul>	<p>Cross-functional exchanges are not spontaneous, do not integrate all the functions, and are not integrated as part of the corporate culture.</p>
<ul style="list-style-type: none"> <li>- Marketing-orientation is strong but needs to be improved.</li> <li>- Data collection is mostly formalised by the marketing department with little involvement from other functions.</li> <li>- The existence of a marketing department:               <ul style="list-style-type: none"> <li>- leads to better environmental scanning and feedback from customers;</li> <li>- favours the development of a marketing culture;</li> <li>- however, it leads to more formal exchanges.</li> </ul> </li> </ul>	<p>Marketing-orientation remains the ownership of the marketing department and is not culturally integrated by other functions. The marketing department favours data collection and general marketing-orientation but it is formal and market-orientation remains concentrated in the hands of marketers.</p>
<ul style="list-style-type: none"> <li>- Medium importance granted to design.</li> <li>- Underestimated role of design management to favour trans-functional collaborations.</li> <li>- Design subordinated to other functions.</li> <li>- Design has an important role to play in high tech companies.</li> </ul>	<p>Design management is not integrated in corporate cultures.</p>



#### 6.4. The transformation process: from 'input' to 'output'

The analysis of the situation to be reached – i.e. the transformed state or 'output' - is based on the literature review – see fig. 2.20 - as well as on some of the answers given in the quantitative stages – e.g. meeting customers' requirements is a priority and design has an important role to play in high tech organisations -. As a result, the transformation process must lead to:

- an organisation with stronger market-orientation;
- an organisation which *culturally* values cross-functional exchanges;
- an organisation which values design management in its corporate culture.

Table 6.2. synthesises the transformation process, including 'input' – i.e. situation of entities – and 'output' – i.e. these entities in a transformed state -. It is illustrated by fig. 6.1.

**Table 6.2. - The transformation process: from 'input' to 'output'**

'Input' of the SSM model or observed state	'Output' of the SSM model or transformed state
Cross-functional exchanges are not spontaneous and do not integrate all the functions.	(Informal) cross-functional exchanges as part of corporate culture.
Marketing-orientation remains the ownership of the marketing department and is not culturally integrated by other functions. The marketing department favours data collection and general marketing-orientation but it is formal and market-orientation remains concentrated in the hands of marketers.	A market-oriented culture shared by the entire organisation.
Design management is not integrated in corporate cultures.	Design management valued in corporate cultures.

**Fig. 6.1. - Pictorial representation of transformation process**

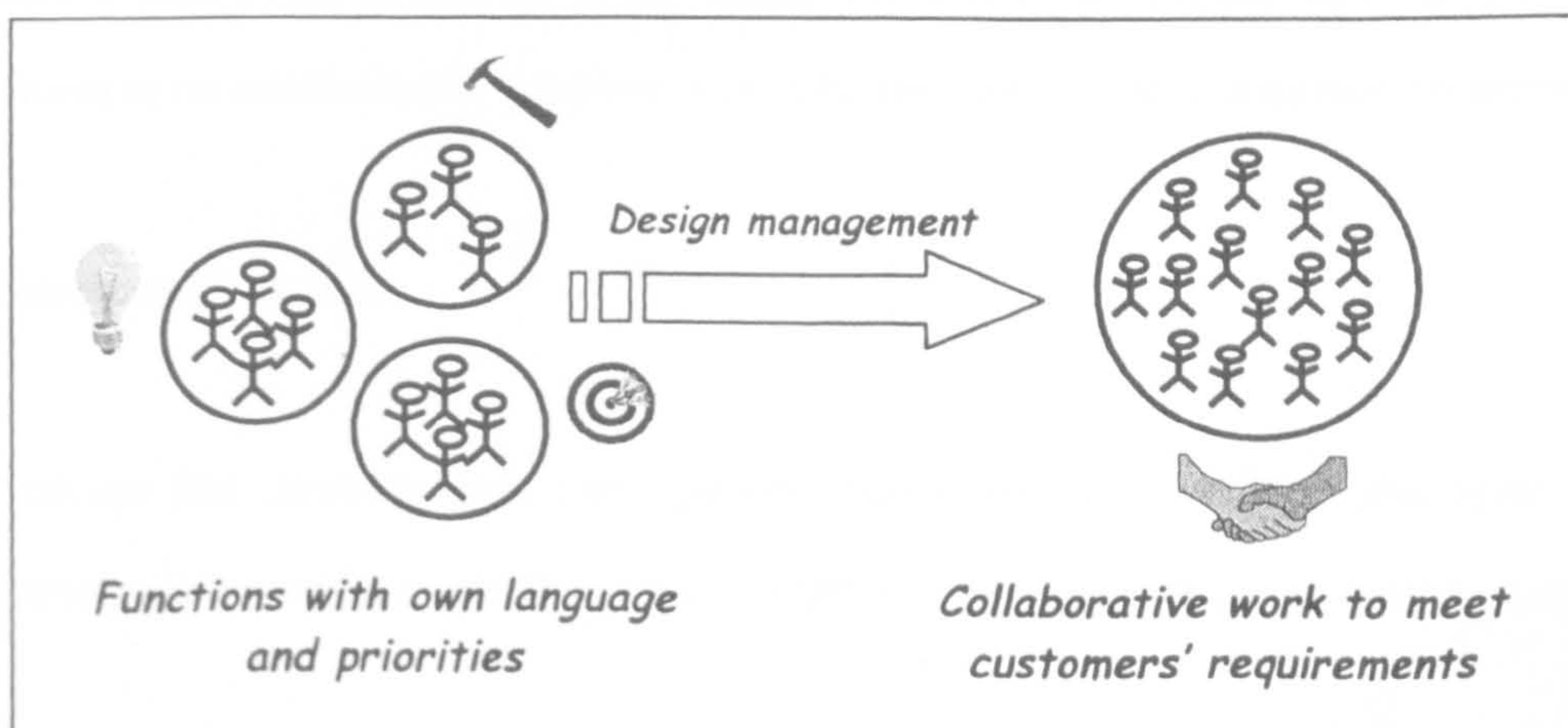



## **6.5. Final model**

### **6.5.1. Factors to be taken into account**

These factors are the ones that influence the actions to be taken. They resulted from the two quantitative stages. These factors are:

- size of organisations;
- management styles;
- quality certification;
- technological intensity and type of activities;
- existence of a marketing department.

#### **6.5.1.1. Size of organisations**

This factor, and to a larger extent, the fact of belonging to a group, will impact on the implementation of the model. In fact, according to their sizes, companies will not have the same organisational structure, neither the same climate nor the same resources. First, as regards functional formalisation, smaller organisations have less formalised departments. Relationships tend to be less formal since there are thinner frontiers and more physical proximity between employees. This was emphasised by the quantitative results. Second, authority will be more centralised in smaller structures since there are less hierarchical levels. For instance, the answers given as regards the role of manager's intuition in the decision showed that it is higher in smaller organisations. Third, resources will not be the same for small and larger companies. This will impact on the type of actions to be take since some solutions will not be directly applicable to organisations with reduced human or financial resources. For instance, purchasing CAD equipment will represent a heavy investment for small organisations and the suggested actions in the final model will have to be moderated or adapted according the sizes of the companies concerned.

#### **6.5.1.2. Management styles**

Literature review has stresses that management styles will influence both the level of inter-functional integration and the adoption and implementation of a design-oriented strategy. As

regards inter-functional collaboration, Thérin (1998), Gupta et al. (1986) and Souder (1981) emphasised the role of top management in providing the right conditions to favour integration: low formalisation and concentration of power as well as collaborative management are constructive environments. The data collected in the two quantitative stages showed that the higher the formalism of top management during NPD, the higher the formalism of the NPD process.

Concerning design management, organisations with design friendly climates – i.e. informal and with little interference but providing a solid guiding vision and framework – will be the most favourable ones (Cooper and Press, 1997; Walker, 1993).

Thus, management styles will also influence the actions to be implemented as regards design management. Some organisations will have more appropriate climates and thus require lighter cultural adaptations. However, management styles will often be linked to the sizes of the organisations.

#### **6.5.1.3. Certification**

Cross-tabulations demonstrated that firms which have an ISO certification show some differences with organisations that are not certified. In the certified companies, NPD processes are more formalised and the importance granted to design management is more reduced. This was also emphasised by the observations made at Wandel & Goltermann. Consequently, the actions to be implemented so as to develop a design-oriented corporate culture will have to take into account the fact that a company is certified or not certified. In fact, it can be considered that design management is easier in uncertified organisations since the general climate is less formalised and since the importance granted to design tends to be higher. On the opposite, certified companies will have to manage in parallel their quality procedures and the introduction of a design-oriented culture.

Even though the quantitative results show that quality certification is detrimental to the importance granted to design, it does not mean that the two cannot co-exist. As stressed by Borja de Mozota (1993), TQM and design share the same objectives: meeting customers' requirements. Introducing design management is a way of conveying quality-focused values. TQM will mainly be concerned

by the quality measured and design by the quality perceived. Thus, design will help emphasising the added value provided by internal quality procedures in the final product. Again, it is the responsibility of top management to communicate internally about the role of design to emphasise the quality incorporated in the final product.

#### **6.5.1.4. Technological intensity**

As mentioned in the literature review, the level of technological intensity will impact on the way organisations are managed. However, it will vary throughout companies' lives (Millier, 1989). It will also vary according to the type of activity (see OECD's classification). Primary research also stressed some organisational differences according to the level of technological intensity – i.e. high tech versus medium/high tech firms -. This will influence the actions to be implemented in the final model. For instance, it was observed that in the high tech + group:

- organisations are more heterogeneous as regards their sizes;
- there is a higher percentage of companies that are not certified;
- there is a higher percentage of companies that have a R&D as well as a marketing department;
- companies tend to have a higher level of collaboration between R&D, marketing and production;
- inter-functional frontiers tend to be thinner;
- environmental scanning and customers' feedback are more important;
- the marketing culture is perceived as more important;
- the importance granted to design and the perception of design as a collaborative function is higher.

Even though the data derived from the two clusters – high tech + and high tech +/- - were globally similar, the above-listed factors outlined that differences also exist. These characteristics will impact on the final model and on the implementation of a design-oriented strategy. Globally, it can be considered that such implementation will be easier in sectors with high levels of technological intensity since:

- inter-functional collaborations are already higher, and frontiers are thinner than in other sectors;
- the information system is more efficient;
- the marketing culture and the importance granted to design are already strong.



Consequently, the level of technological intensity will have to be taken into account when considering the implementation of the final model.

#### **6.5.1.5. Existence of a marketing department**

The observations made at Wandel & Goltermann together with primary data collection showed that the existence of a marketing department influences the organisation at different levels. First, companies with a marketing function have a more formalised NPD process. Second, as regards the information system, there is a strong dependence between the existence of a marketing department and the formalisation of environmental scanning. In companies where there is a marketing function, environmental scanning is more formalised. Third, organisations with a marketing function have a stronger marketing culture. This leads to a higher importance granted to feedback from customers.

Moreover, and as stressed by the literature review, the existence of a marketing department also generates disharmony with R&D. This emphasises the need for a neutral and integrating function that can help increasing cross-functional collaboration. At this level, design management can contribute to create a common language and to promote common objectives based on customers' requirements.

In the final model, the above-listed factors, which appear on top of the chart, directly influence the organisation. The actions to be implemented will have to take these elements into account.

#### **6.5.2. Final model: actions to be implemented**

As recommended in the SSM approach, the actions to be implemented are issued from the comparison between the situation to be reached – i.e. information collected in the literature review and synthesised in fig. 2.20. - and the current situation – i.e. information collected in the two quantitative stages and synthesised in fig. 5.1. -. The final model is presented in fig. 6.2. and shows the actions to be implemented in order to bridge the gap between the present state and the desired state.

**Fig. 6.2. - Actions to implement design management as an integrating function in high tech organisations operating in France**

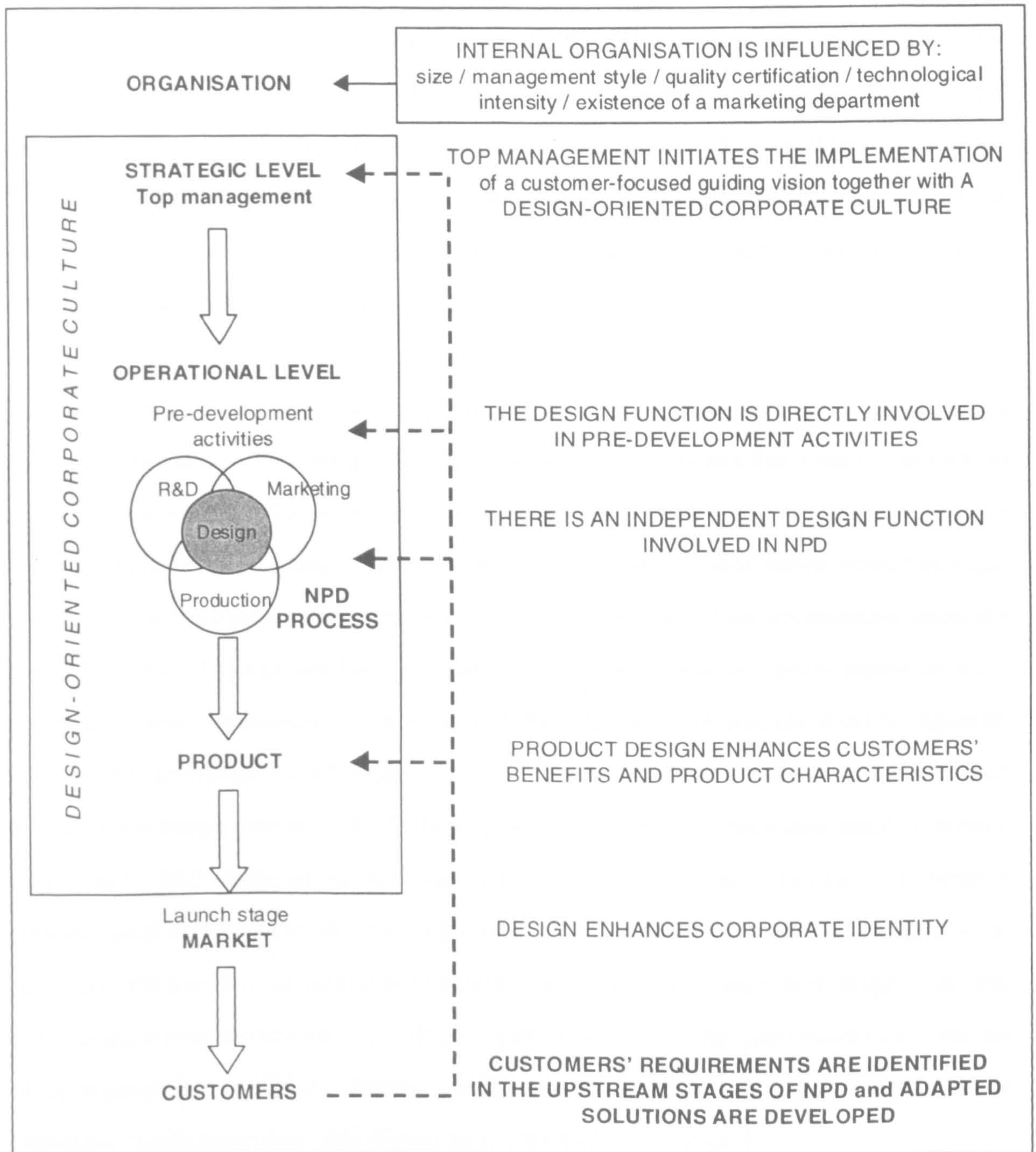

Fig. 6.2. presents the main actions to be implemented. Each component of the model will be detailed in the next sections which will also include the comments made by the managers of five high tech companies, the objective being to be as practical as possible (see methodology, chapter 3). Details concerning the companies interviewed are provided in appendix 5.



### **6.5.2.1. The decisive role of top management**

As explained in the literature review, the increasing pressure to provide solutions that are better adapted to customers' requirements initially came from the external environment – e.g. higher competitive force and growing customer awareness -. However, as shown in table 6.3. - i.e. the CATWOE mnemonic -, the transformation process will internally be initiated by top management who is responsible for setting corporate objectives and for providing a structure and adequate resources to favour the implementation of design management.

In order to adopt a design-oriented corporate culture, top managers will first have to deeply understand the benefits it will bring to the organisation, including the fact that it will enable them to reinforce customer focus. Top managers will then be responsible for communicating their vision to all the functions in the company. This was mentioned by Agnès Cornière, senior product manager at Hercules Technologies, who insisted on the fact that managers must communicate about the impact that efficient design will have on customers and, eventually, on market shares so as to convince the entire organisation. As stressed by Patrick Cloarec (LEA) the role of top management will be both to emphasise the advantages brought by design but also to clearly set the role of each function in the design process. "The marketing department is the one that knows about customers' requirements. R&D knows about technical aspects. In order to avoid disharmony, the fields of competence of each function must be clearly set". As for Daniel Henry (e-generis), "a 'guru' – i.e. somebody with a very strong personality and who has understood the benefits of design – can help convincing the other employees". According to Bernard Badefort (Philips semi-conductors), the role of top management to initiate a design orientation is the same as when implementing a quality orientation. "Commitment from top management is definitely a corner stone".

Moreover, an important aspect to be taken into account at this stage is that business and design objectives will have to be presented as complementary and, even, mutually reinforcing one another, as it was stressed in the literature review. Moreover, top management will also have to favour the progressive integration of design in the organisational structure in order to overcome corporate resistances. This can be done according to the four stages specified by Woolley (1999): familiarisation, reciprocation, integration and consolidation, when no independent design function



previously existed in the organisation. However, as stressed by the results of the quantitative stages, the creation of an independent design function will enable the spreading of a 'design culture' throughout the entire organisation and increase design consciousness.

The efficient development of a design orientation will also require that top management provides a design-friendly environment, "a transparent bowl", as stated by Walker (1993). When considering the results of the quantitative stages, managers will have to become less intrusive in the innovation process so as to provide the most appropriate context for creativity. This confirms the results of the study conducted by Gupta et al. (1986) for whom lower formalisation and concentration of power will increase the level of cross-functional integration.

Adopting a design oriented strategy will also suppose that the necessary resources are dedicated to design, both in terms of financial and human means. It will include the charges of hiring designers – internal or external -, purchasing the necessary equipment but also the cost of the necessary organisational restructuring. However, as mentioned earlier, resources will vary according to the size of the organisation concerned. Smaller companies may not have the necessary funds to hire a team of designers or to purchase CAD equipment. However, they can still initiate a design-oriented corporate culture by sensitising all the actors of the NPD process. Moreover, even though a formal design function is not created, a designer can be hired or an employee can be trained as a starting point for activating the implementation of a design-oriented culture. An alternative solution can be to work in collaboration with a design consultant who will make a design audit and advise top management about the changes and corresponding actions to be implemented. According to Patrick Cloarec, General Manager of LEA, and former independent consultant, working with a consultant is a good solution to initiate the change. However, he insisted on the fact that the consulting work must be done in direct collaboration with top management so that the organisation gradually becomes autonomous. Top management initiates the design-orientation by hiring a design consultant but it is the consultant's responsibility to provide adequate support and guidance so that top management remains the main actor at the centre of the process. In fact this corroborates Roy and Potter's statement (1990) according to which "such [small] firms require additional help and advice if they are to use external resources effectively".

### **6.5.2.2. Pre-development activities and NPD process**

The actors to be directly impacted by the implementation of a design-oriented strategy are primarily managers and employees of the R&D, marketing and production departments as well as the designers. At the operational and functional levels, people will have to adapt to the new organisational structure that the adoption of design management will generate. This point was outlined by Alain Le Hénaff, marketing manager at Acterna (formerly Wandel & Goltermann). According to him, an efficient design strategy supposes that the organisation has adopted a multidisciplinary approach in order to have efficient trans-functional communication, which will guarantee an homogeneous message.

At the functional level, the creation of an independent design function will also change the way NPD is managed. Roles will have to be clearly set by top management, and middle managers will be responsible for monitoring the new NPD process. In organisations in which a function is dominating the others, thus, creating sources of disharmony (Souder, 1981), the first role of the design function will be to act as a neutral co-ordinator and a catalyst of the different inputs. Even if it is recommended that the design function is independent, it will have to collaborate with R&D, marketing and production to create synergy and to harmonise the NPD process. Such collaborations will begin during pre-development activities.

The design function will have to work with the marketing department for the market research stage but also throughout the whole NPD process to ensure consistency between the marketing strategy and the design strategy. This necessary collaboration between marketing and design was outlined by all the managers interviewed as a central element in the design process. In fact, as stressed by the data collected in the field surveys, the existence of a marketing department favours better environmental scanning and customers' feedback. Both functions – i.e. design and marketing - will feed the information system so as to be able to identify the nature of the demand. The marketing department will act as an interface with the sales force, thus, supplying field information. It will also provide data as regards the environment, including competitors, economic, legal, political and social factors. By nature, the designers will also have a role to play in feeding the information system with data relating to the new social and fashion trends, technical norms, etc. At this stage,

and especially in the case of the improvement of an existing product, the relationship between the design function and the after sales service will also be of tremendous importance to gain knowledge about the product potential problems. This point was emphasised by Patrick Cloarec (LEA) as a vital issue for incremental innovations.

Concept-testing will also require that both the marketing and the design functions collaborate. This necessary, and even, natural collaboration between marketing and design was also stressed by Patrick Cloarec (LEA). According to him, design and marketing tend to get closer when it comes to issues relating to user interfaces. The two functions share common objectives mostly relating to user friendliness. At the concept-testing stage, all the traditional methods of market research – e.g. focus groups, interviews, etc. – are likely to be used. However, they will be complemented by the use of computer-aided techniques which will enable to visualise the product concepts with a high level of realism and help interacting with the potential users. This will finally lead to a better understanding of customers' requirements – THE decisive point mentioned by the companies surveyed -, as well as to a sharper definition of the product to be develop. According to Bernard Badefort (Philips semi-conductors Rennes) inviting end users to give their opinions during the NPD process will positively impact on their perceptions of the company and increase their confidence in the final product. Moreover, it will avoid taking misleading directions in the future NPD steps (Loosschilder, 1995; Woolley, 1999). Eventually, in the final design stage, it will enable the designers to emphasise the aspects of the product that were identified as critical for the end users – i.e. objective and concrete factors such as materials, functions, etc; but also more subjective factors such as the social or psychological perception of the product -.

Supposing that the pre-development activities have been efficiently conducted, the product concept to be developed will be clearly defined. It will be a helpful basis to exchange with other functions, and especially, as stressed by Bernard Badefort, Director of Philips semi-conductors Rennes, with the production department in order to evaluate manufacturing constraints. Moreover, the visualisation of the product concept to be developed will also help communicating objectives to the other functions with a simple and common language and in a more informal context. This will be decisive for the NPD process.



Once the characteristics of the products are defined, the design function will be responsible for co-ordinating the inputs from all the functions involved in the NPD process. Product data management (PDM) will play a crucial role, each function being able to feed and consult the data basis to integrate its own constraints. For instance, the production department will be able to visualise the product and consider how components can be adapted for easiness to manufacture. It will also help for the production of prototypes.

Above all, having an independent function in charge of co-ordinating the NPD process which is able to use a common trans-functional language will decrease the number of iterations, misunderstandings and conflicts and will finally shorten pre-launch delays. However, design management will have to be supported by different measures so as to amplify the level of inter-functional collaborations. As stressed by Thérin (1998), training employees so that they learn one another's disciplines and communicating marketing research results and changes in customers' tastes will also help increasing interfaces. In fact, by gaining deeper knowledge about the other functions, people from the R&D, marketing and production departments will be likely to understand the reasons why priorities often differ. Moreover, such understanding will increase shared knowledge and thus create wider areas of exchanges. As concerns information about the market and customers, an efficient information system must be implemented for the purpose of collecting and circulating the data throughout the entire organisation. This will enable managers to make the requirements to be answered more concrete and it will create common references for all the employees as regards the objective to be reached.

#### **6.5.2.3. Final product**

An important paradox that emerged from the quantitative stages is that most companies consider that a reliable and user-friendly product is decisive for success, whereas little consideration is actually granted to design management. Emphasising the added value that design will bring to the final product is essential to convince the entire organisation, including top managers, to develop a design-oriented corporate culture.

Thus, the first and decisive advantage that efficient design management will provide is that it will prioritise customers' benefits. As mentioned by Woolley (1999), some important characteristics of

the product may need to be reinforced and made visible so as to reassure the buyer. These characteristics can be tangible – e.g. solidity -, but also less tangible – e.g. high degree of innovation, technological performance, etc. -. As mentioned earlier, and as stressed by Borja de Mozota (1993), appropriate design will be a way of valuing such features, thus increasing the level of quality perceived. This will be even more important for certified companies. In fact, according to Bernard Badefort (Philips semi-conductors Rennes), design and quality cannot be separated, they are mutually reinforcing.

Second, design will value technical as well as technological inputs. Not only will it make such contributions visible but it will also be a way of decreasing the demands-to-satisfaction ratio – i.e. the resistances that a high tech product may generate - (Feldman, 1995; Franzén et al., 1995). In fact, this may sound like a paradox since emphasising technological aspects is likely to increase users' reluctance to adopt innovation. The difficult task at this stage will be to make technological added value perceptible while increasing user-friendliness. It will be the role of the designers to understand the technical and technological inputs incorporated in the product and to highlight them through appropriate design. As mentioned by Agnès Cornière, (Hercules Technologies) “design is a decisive strategic factor to reassure end users about technology”.

#### **6.5.2.4. Product launch on the market**

Efficient design will also be a way of amplifying corporate identity, thus differentiating the product from its competitors. This was stressed by Agnès Cornière (Hercules Technologies) as being a major benefit of the design strategy. However, the results from the two quantitative stages showed that design-related issues are not a managerial priority among the high tech companies operating in France. Consequently, the first step will be that corporate identity is well-defined by top management – see strategic level in the chart -. In fact, the features conveyed by the final product must be coherent with the firm's strategy and with the image that top management wants to communicate. Product features must also be consistent with the marketing mix – price, promotion and distribution -. This supposes that top management, the marketing department and the design function collaborate in the earlier stages of NPD so as to harmonise the marketing and design strategies with corporate objectives and identity. However, managers will have to understand that this harmonisation will result from a global corporate strategy and will not only be a communication

issue, as stressed by Bernard Badefort (Philips semi-conductors Rennes). In fact, according to Agnès Cornière (Hercules Technologies), it is not always easy for a company to respect design standards at the product level. However, according to her, whenever corporate identity is not clearly reflected in the final product, other features such as packaging or graphic design must intervene to emphasise the firm's identity.

#### **6.5.2.5. Customers**

Meeting customers' requirements was mentioned as the number one priority by the managers interviewed in the quantitative stages but it also appeared that little was actually done to have a strong customer focus. By integrating end users in the early stages of the NPD process, design management helps to make a sharper definition of their users' needs and eventually provides adapted solutions. This was stressed by Agnès Cornière (Hercules Technologies) as being a crucial step in the validation of the product concept. She also outlined the importance of visualisation tools such as sketches to validate the adequacy between design and the messages perceived by the potential end-users.

As shown in the model – see arrows in dotted lines -, design management, will enable the organisation to put the customer at the heart of the NPD process. By doing so, and in collaboration with the marketing department, managers will have more information about their markets. At the strategic level, top management will benefit from more customers' feedback, which will reduce market uncertainty and lead to better forecasts as well to customer-focused strategies. At the pre-development and NPD levels, integration of customers, especially in the testing stages, will enable the different departments to centre their decisions on the same priorities. This will increase cross-functional dialogue and co-operations. At the product level, efficient design will enhance customers' benefits and thus make the product user-friendlier. Eventually, customers will be offered adapted solutions to their needs. This will increase their satisfaction, and thus, brand loyalty, market share and eventually profits. Moreover, as stressed by Daniel Henry (e-generis) product success will also be a source of motivation for the employees, which will act as a catalyst of the design orientation, thus creating a virtuous circle.



## **6.6. Conclusions**

The model presented in fig. 6.2. synthesises the actions to be taken to initiate and implement a design-oriented strategy in the high tech companies operating in France. In this model, design management acts as an integrating function which increases cross-functional collaborations and, above all, helps to incorporate customers in the NPD process. By doing so, the organisation is able to increase its chances of success by providing solutions which are better adapted to its end-users. However, each organisation is different from the other and adaptations have to be considered according to the firm's characteristics, some internal contexts being more appropriate than others to the implementation of a design-oriented corporate culture. The only factor that will not vary is that top management is responsible for making the initial decision of considering the advantages that design management can bring to their organisations in terms of customers' satisfaction.

### **6.6.1. Contribution to new thinking and impact on existing theories**

As stressed in the literature review, high tech sectors have to face different constraints. As regards their external environments, they are submitted to high uncertainty and are under pressure to be more reactive. At an organisational level, cross-functional relationships – especially between R&D and marketing – are often made difficult due to cultural differences and divergent priorities. Eventually, at the product level, customers are often reluctant to adopt highly innovative solutions. Even though these characteristics have been outlined by many researchers, design management has never been emphasised as an integrating function for high tech companies operating in France. Nor have the actions to be implemented clearly been stated in previous pieces of research. Thus, the main contribution to new thinking of the present piece of research is the final model that synthesises the main actions to be taken in order to initiate and develop an integrating design management oriented strategy in the French high tech organisations.

Moreover, the surveys launched among the high tech companies operating in France provided a diagnosis of the situation as regards NPD strategies and actual cross-functional relationships but also as regards the perception managers have of design management. These data also stressed that different factors impact on both NPD management and on the importance granted to design – e.g. quality certification, existence of a marketing department, existence of a design function -.

Above all, the research has paved the way for further investigation in the field of design management among the French business environment since it is clearly an underestimated discipline.

The literature review also contrasted the perceptions and role of design management in France and the way it is perceived in other countries, especially Anglo-Saxon ones. Whereas design management emerged in the 80's in the UK (Press, 1995, Cooper and Press, 1999), it is a recent issue in France and different researchers (Liemens, 1994; Tissier Desbordes and Fialho, 1994) have pointed out the difficulty of imposing design as a strategic function in the French business environment. Consequently, one major output of the present piece of research has consisted of a review of French as well as Anglo-Saxon literature relating to design management which has opened the way for further comparative investigation (see section 6.6.3.).

As stressed in the section dedicated to NPD, researchers have often provided 'recipes' or checklists when considering the factors that can guide organisations towards success. Such approaches fail to provide clear guidance as regards the actions to be implemented to reach the 'expected' situation. Recent literature (Jensen and Harmsen, 2000) outlined that despite of all the studies that have been conducted to help managers building an efficient NPD strategy, little application is actually observed in companies. This may, in fact, be explained by the fact that research often neglects the aspects of practical business application of the findings. Measuring the gap between the 'real world' situation and the situation to be reached and being able to make concrete recommendations was the main argument for using SSM in the present piece of research. However, as stressed in section 6.6.3. the recommendations provided in the present piece of research will require that efficient complementary actions be taken so as to sensitise key decision-makers and managers to the role that design management can play in their organisations. In this respect, the fact of having done research in this field is the first step to 'pull' the process but it must be followed by practical actions to spread the knowledge gained over the business community.

Another factor to outline concerns the differences that exist among firms. Providing solutions without taking into account the context in which companies evolve, their sizes, management styles, organisational structure or type of activities can only lead to vague recommendations which will then require important adaptations that may seem hard to implement. Again, this generates little

effective business applications. Even though research cannot always provide customised answers to business problems, it must consider and stress the major organisational differences that have to be taken into account for simpler and more efficient implementation of the findings.

#### **6.6.2. Limits of the research**

Some biases might have influenced the results of the present piece of research and are presented in this section.

The first remark concerns the notions of design and design management as perceived by the respondents. As stressed in the literature review, the term 'design' covers a wide spectrum of activities and is often understood as a synonym of aesthetics or ergonomics. Since the managers interviewed in the quantitative surveys are, on average, not very familiar with design, the meaning that they have given to this concept in the two questionnaires might have been different from the concept of design as understood by the researcher. However, even though this potential source of bias was considered at the beginning of the primary data collection stages, the researcher made the choice not to provide a definition of design in the surveys in order not to influence the respondents' perceptions of design. Eventually, the answers given verified that little attention was granted to design among the high tech companies and corroborated the fact that having introduced complex explanation would also have biased the results.

The second remark concerns the first exploratory stage. Since the objective, at this stage, was to make a wide diagnosis of the situation, it must be admitted that the questionnaire was very long, which might have dissuaded some respondents from returning it fully completed. This explains the 3% return rate.

The third limit relates to the sizes of the organisations in the final samples. In the original population, the proportion of firms with less than 200 employees was a little higher than in the final samples of the two surveys. The fact of having concentrated on inter-functional relationships has impacted on the nature of the sample. In fact, organisations had to have marketing, R&D and manufacturing functions in order to be concerned by the research problem. This has led to the fact that companies that returned the questionnaires were companies with quite formalised



organisational structures, and thus, often larger than initially planned. Moreover, very large organisations, with more than 500 people, have been more numerous than in the national. This can be explained by the fact that they might have felt more concerned by the research topic.

Another issue concerns the sample chosen for the last qualitative stage which was based on the knowledge the researcher had of the companies selected. However, it must be stressed that the objective at that stage was not to implement a statistical validation of the model, but, rather, to collect practical recommendations in order to illustrate the discussion, the final model being already derived from statistical data.

Eventually, the variables analysed in the present piece of research were considered to be the most relevant as regards the research questions. However, the data collected throughout the research process, and especially during the two quantitative stages, will be further exploited for academic as well as professional purposes. In fact, articles are being written in collaboration with The Department of Design of Brunel University and will be submitted to conference and publication committees.

### **6.6.3. Recommendations for further research**

First, the results derived from the two quantitative surveys showed that companies with the highest levels of technological intensity tend to be more marketing and market-oriented than the other sectors. Since much literature has stressed the weaknesses of high tech firms as regards marketing issues, it would be relevant to implement further research in this direction to see whether these results actually depict reality or whether it is just due to the perception managers have of their organisations – i.e. over-estimating their marketing and market orientation .

As stressed in the section dedicated to the limits of the present research, the definition of design is not clear for most managers. Gaining better understanding of the meanings associated with the notion of design among the French companies is a first axis for further research which was mentioned by all the managers interviewed in the qualitative stage. This could eventually enable future researchers to consider the actions to be taken so as to change the perception that French managers have of design. Moreover, in order to avoid reduced applicability of the research in the

business environment (Jensen and Harmsen, 2000), future researchers should consider practical ways of sensitising managers to the role of design management in their organisations. Publishing recommendations in business reviews, organising conferences in the business environment and training managers in design management issues are different ways of initiating a design management culture among the French managers. In fact, such actions have already been undertaken at a local and regional level by the researcher and has proved to be an efficient way of instigating an interest for design management issues among the business community (Séguier, 2000; Anonymous/EKO, 2001). Moreover, the collaboration between a French business school and a British design institute through this research has created an opportunity for ongoing dialogue on curriculum development and student exchanges.

As concerns the impact of design strategies, it could be relevant to distinguish between mass markets and business-to-business activities. In fact, as stressed by the marketing manager of WG France, it seems that companies operating in a B-to-B context tend to consider that design does not bring a major competitive advantage on industrial markets. Initiating research as regards the role of design management in a B-to-B environment would enable researchers to make appropriate recommendations for the French industrial fields of activity.

Another recommendation concerns the comparison of the results relating to the high tech companies operating in France with the situation in other countries. In fact, the differences that exist between nations was stressed by different researchers (Anselin, 1998; Tissier-Desbordes and Fialho, 1994). Comparing the situation in France with other nations would enable researchers to gain deeper knowledge of the nature of the gaps that separate France from its international competitors. More precisely, this would allow deeper understanding of the cultural reluctance and barriers to the development of design management in the French business environment. Eventually, appropriate recommendations could be made to improve the role of design both at a national and at an international level.

At the organisational level, it would also be relevant to follow up the actual implementation of a design-oriented strategy in a high tech organisation, from the initial stages at the top management level to the eventual impact on the firm's long term results. This would provide detailed information as regards the constraints to be dealt with in terms of corporate culture, management of change,

monitoring, etc. as well as about the practical impact of design in terms cross-functional collaborations and product success in the market place. Again, this would enable researchers to gain deeper insight of the barriers that must be overcome in order to convince key decision and policy makers within the French organisations.

As regards design management and TQM, a major factor has emerged from the quantitative data collected for the present piece of research, which is the dependency between quality certification and the importance granted to design management. Whereas previous research outlined that TQM and design management share the same goals, it actually appears that this is far from being understood by the companies. In fact, this also opens the way for further research in order to analyse how TQM and design management can practically be harmonised and implemented in a given organisation.

Eventually, looking at the impact of a design-oriented strategy on external factors such as uncertainty is another axis for further research. In fact, literature research showed that three major types of uncertainty will impact on high tech organisations: market, technological and technical uncertainty (Porter, 1999; Price, 1996; Jones and Fearis, 1995; MacInnis and Heslop, 1990; Moriarty et al., 1989; Millier, 1989). The implementation of a design-oriented strategy could reduce uncertainty since top management will have deeper knowledge of the nature of demand as well as of technical and technological constraints. Such information will, for instance, enable managers to have more visibility and to make sharper forecasts. Consequently, even though the organisation has no direct control over uncontrollable factors such as uncertainty, need for reactivity or political, economic and social changes, the design strategy can act as a filter to moderate the impact of such pressures.

So, even though the quantitative stages did not show direct evidence of the effect of design management on external uncontrollable factors, it can be assumed that the design strategy could act as a filter and moderator of the impact of such pressures. Fig. 6.3. shows the organisation in its environment and includes the potential impact of a design-oriented strategy on the external factors,



Fig. 6.3. - Model expanded to external uncontrollable factors

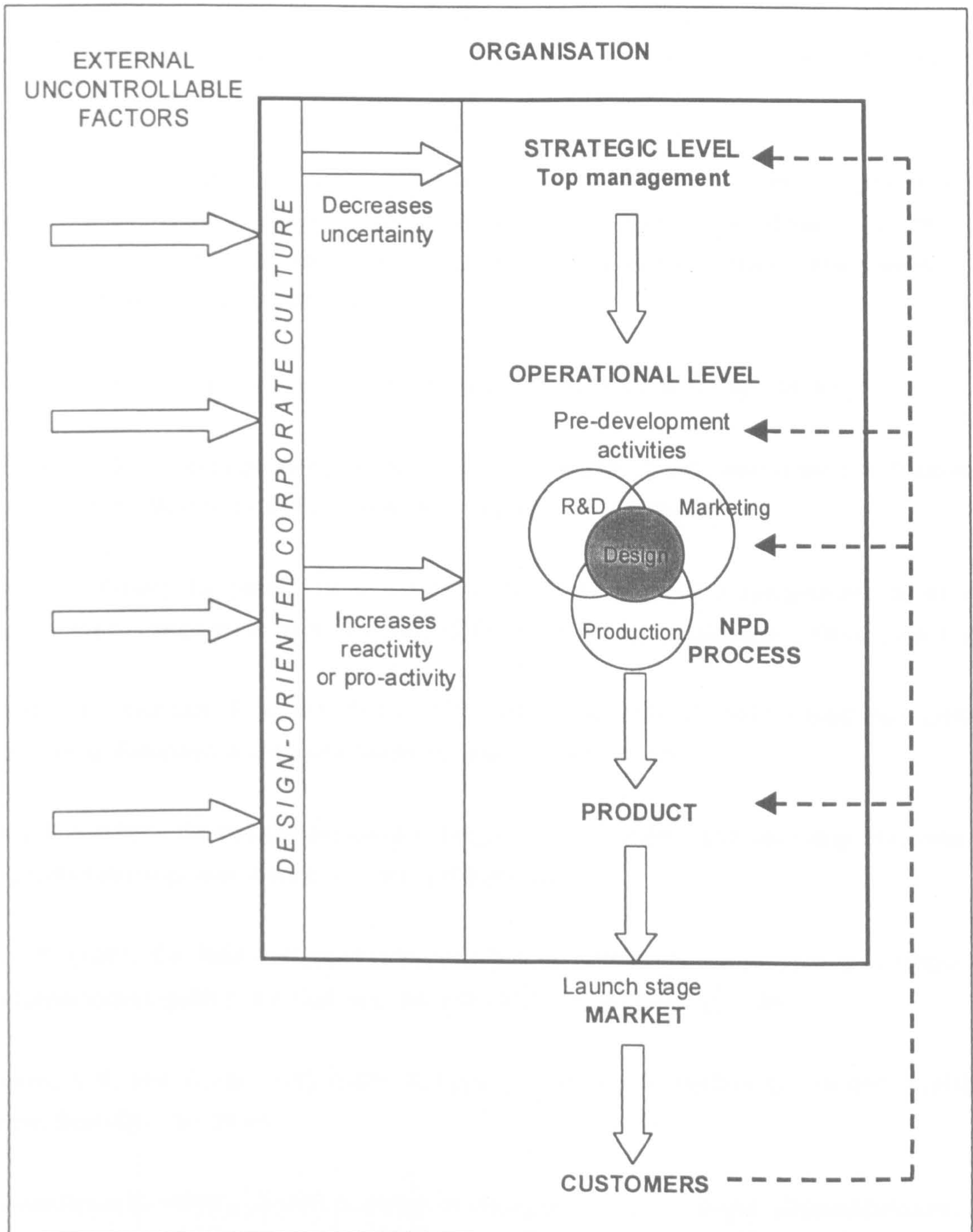

The directions for further research presented in this section open the way to new perspectives for the study of design management at organisational, national and international levels. Since design appeared to be an underestimated discipline among the French business environment it can be anticipated that future researchers will contribute to emphasise its legitimacy. As mentioned by Topalian (1994), "design certainly presents some of the most stringent intellectual challenges in business!".

## REFERENCES

- ADLER, P.S., MANDELBAUM, A., NGUYEN, V. AND SCHWERER, E. (1996), Getting the most out of your product development process. *Harvard Business Review*, March-April.
- ANDERSON, P., WOOD, B.M., AKSNES, D., KIRPATRICK, J. AND VAN DIJK, F. (1993), Integration of design management within product design at Glasgow School of Art. *Proceedings of the Fifth International Forum on Design Management Research and Education: "Design Perspectives: Tools, Processes and Users"*. MIT, July 14-16.
- Anonymous (2001), Design et technologies, le beau ne suffit plus. *EKO*, No 161, May.
- ANSELIN, G. (1998), *Stratégie design et développement international de l'entreprise*. Les Presses du Management, Ministère de l'Economie, des Finances et de l'Industrie
- ANTOINE, A. (1994), La gestion de la qualité: atout ou obstacle au développement du design industriel. *Proceedings of the Sixth International Forum on Design Management*. Paris, June 1-3.
- AVISON, D.E., GOLDER, P.A. AND SHAH, H.U. (1992), Towards an SSM toolkit: rich picture diagramming. *European Journal of Information Systems*, vol. 1, No 6.
- AYERS, D.J. (1994), *Control combinations in the governance of R&D and marketing integration in new product development*. Thesis, University of Kentucky.
- BAILE, S. (1997), De l'informatique aux technologies de l'information: économie et stratégie de développement en gestion d'entreprises. *Gestion 2000*, July-Aug, pp. 149-168.
- BALDWIN, C.Y., AND CLARK, K.B. (1997), Managing in an age of modularity. *Harvard Business Review*, Sept.-Oct., pp. 84-93.
- BAUHAIN-ROUX, D. (1992), *Gestion du design et management de l'entreprise*. Chotard Editeurs.
- BECKWITH, D. AND HARRIS, D. (1993), The megateam design process: adding a new dimension to concurrent development. *Design Management Journal*, Fall, pp. 69-77.
- BENTLEY, T. (1993), Soft systems methodology. *Management Accounting*, July-August, vol. 71, issue 7.
- BOLTON, S. AND WILLIAMS, A. (1995), Issues affecting product design practice: another good solution to the wrong problem. *Proceedings of the European Academy of Design Conference: "Design Interface"*, 11-13 April.



- BOOZ ALLEN AND HAMILTON (1982), Management of new products for the 1980's. BAH.
- BORJA DE MOZOTA, B. (1993), Total quality Management and design management excellence. *Proceedings of the Fifth International Forum on Design Management Research and Education: "Design Perspectives: Tools, Processes and Users"*. MIT, July 14-16.
- BOUVARD, J. (1998), Marketing activity in high-tech companies: a review of the relevant literature. *Gestion 2000*, Nov.-Dec.
- BOWEN, H.K., CLARK, K.B., HOLLOWAY, C.A. AND WHEELWRIGHT, S.C. (1994), *Development project: the engine of renewal*. Harvard Business Review, Sept.-Oct., in *The product development challenge*. Harvard Business School Press (1995).
- BRAIDEN, P.M., ALDERMAN, N. AND TWAITES, A.T. (1993), Engineering design and product development and its relationship to manufacturing: a programme of case study research in British companies. *International Journal of Production Economics*, pp. 265-272.
- BRIARD, C. (1999), Design, des scénarios pour le futur. *L'Usine Nouvelle*, Dec. 16, pp. 70-77.
- BRONTE-STEWART, M. (1999), Regarding rich picture as tools for communicating in information systems development. *Computing and Information Systems*, vol. 6, pp. 83-102.
- BURCHILL, G.W. (1993), *Concept engineering: an investigation of time vs. market orientation in product concept development*. Thesis, Massachusetts Institute of Technology.
- BURNETTE, C. AND CARREIRO, J. (1993), Integrating design, management, and communications systems. *Proceedings of the Fifth International Forum on Design Management Research and Education: "Design Perspectives: Tools, Processes and Users"*. MIT, July 14-16.
- CEGARRA, J.-J. AND HETZEL, P. (1997), La gestion des projets de design: déroulement des projets et modalités de fonctionnement. *Gestion 2000*, Sept.-Oct.
- CHANG, W. AND LANGRISH, J. (1993), Design management: a study of the initial stages of product Modifications. *Proceedings of the Fifth International Forum on Design Management Research and Education: "Design Perspectives: Tools, Processes and Users"*. MIT, July 14-16.
- CHECKLAND, P. AND SHOLES, J. (1990), *Soft systems methodology in action*. Wiley.
- CHEVALIER, M.T. (2000), Le high tech toujours en pleine santé. *Le Figaro*, Nov. 20, pp. 32-33.
- COHENDET, P., LLERENA, P. AND MUTEL, B. (1992), *Flexibilités et mise en cohérence des données de production in Les nouvelles rationalisations de la production*. Cépaduès Editions.



- COOPER, R.G. (1979), The dimensions of industrial new product success and failure. *Journal of Marketing*, vol. 43, Summer, pp. 93-103.
- COOPER, R.G. (1988), Predevelopment activities determine new product success. *Industrial Marketing Management*, pp. 237-247.
- COOPER, R.G. (1990), Stage-gate systems: a new tool for managing new products. *Business Horizons*, May-June, pp. 44-54.
- COOPER, R.G. (1994), *Winning at new products*. Second Edition. Addison-Wesley.
- COOPER, R. AND JONES, T. (1994), Successful design interfaces in NPD: using diagnosis tools to identify weakness in the functional relationships in NPD in manufacturing industries. *Proceedings of the Sixth International Forum on Design Management*. Paris, June 1-3.
- COOPER, R. AND CHEW, W.B. (1996), Control tomorrow's costs through today's designs. *Harvard Business Review*, Jan.-Feb., pp. 88-97.
- COOPER, R. AND PRESS, M. (1997), Design as a strategic resource for management. *Gestion 2000*, Sept.-Oct., pp. 91-108.
- COOPER, R. AND PRESS, M. (1999), Heroes and villains? *The contradictory and diverse nature of design management in Managing new product innovation*. Jerrard, B., Newport R. and Trueman M. Taylor and Francis.
- COOPER, R.G. AND KLEINSCHMIDT, E.J. (1987), New products: what separate winners from losers? *Journal of Production Innovation Management*, vol. 4, pp. 169-184.
- COOPER, R.G. AND KLEINSCHMIDT, E.J. (1988), Resource allocation in the new product process. *Industrial Marketing Management*, pp. 249-262.
- CROTTY, M. AND PAMPLIN, A. (1993), design development and promotion in a small industrial Environment. *Proceedings of the Fifth International Forum on Design Management Research and Education: "Design Perspectives: Tools, Processes and Users"*. MIT, July 14-16.
- DE TERSSAC, G. AND DUBOIS, P. (1992), *Les rationalisations : quels choix pour quelles conséquences ?*, in *Les nouvelles rationalisations de la production*. Cépaduès Editions.
- DIRECTION DE L'ACTION RÉGIONALE ET DE LA PETITE ET MOYENNE INDUSTRIE – DARPMI - (1995), *Les PMI françaises et le design*. Editions du Ministère de l'Industrie, Collection Etudes.

- DORJAHN, R.V. (1995), Streamlining the front end of the product development process. *Proceedings of ESOMAR seminar on successful product engineering, Berlin (Germany), Feb. 22-24.*
- DUMAINE, B. (1989), How managers can succeed through speed. *Fortune*, Feb.13, pp.30-35.
- DURAND, J.-P. (1994), Vers un nouveau système productif ? *Sciences Humaines*, No 39, May, pp. 10-13.
- ETTIGHOFFER, D., AND BLANC, G. (1998), *Le Syndrome de Chronos*. Dunod.
- FAUST, W. (1993), Cross-functional teams in design: a case study of the Thermos Thermal Electric Grill. *Design Management Journal*, Fall, pp. 28-33.
- FAYOLLE, C. (1998), *Le design*. Editions Scala. Collection Tableaux Choisis.
- FRANZÉN, S., HEDMAN, J. AND SVENGREN, E. (1995), The human dimension: a marketing perspective of a humanistic design. *Proceedings of the 7<sup>th</sup> International Forum on Design Management Research and Education, The Design Management Institute, "Connecting Value". Stanford University, July 9-12.*
- FREEMAN, C., AND SOETE, L. (1997), *The economics of industrial innovation*. Pinter Publishers.
- FUJIMOTO, T. (1989), *Organizations for effective product development: the case of the global automotive industry*, vol. 1 and 2. Thesis, Harvard University.
- GAREL, G. (1994), *Réduction du temps de conception, concourance et savoirs professionnels: le cas de l'emboutissage dans les projets automobiles*. Thesis, Ecole Polytechnique.
- GATÉ, J.-C. (1998), *Design de A à Z*. Secrétariat d'Etat à l'Industrie.
- GIANNELLONI, J.L. AND VERNETTE, E. (1995), *Etudes de marché*. Vuibert.
- GIARD, J. AND LEE, G. (1994), Concurrent product development and industrial design education: an experiment. *Proceedings of the Sixth International Forum on Design Management*. Paris, June 1-3.
- GRUNDY, C. (1995), Studies of human behaviour and perception applied to the design of user interfaces. *Proceedings of the European Academy of Design Conference: "Design Interface"*, April 11-13
- GUPTA, A.K., RAJ, S.P. AND WILEMON, D. (1986), A model for studying R&D-marketing interface in the product innovation process. *Journal of Marketing*, vol. 50, April, pp. 7-17.

- GUPTA, A.K., RAJ, S.P. AND WILEMON, D. (1987), Managing the R&D-marketing interface, *Research Management*, March-April, pp38-43 in *New product development, a reader*. Susan Hart (1996).
- HART, S. (1993), Dimensions of success in NPD: an exploratory investigation. *Journal of Marketing Management*, vol. 9, pp. 23-41.
- HART, S., TZOKAS, N., AND SAREN, M. (1999), The effectiveness of market information in enhancing new product success rates. *European Journal of Innovation Management*, vol. 2, issue 1.
- HARTLEY, J. (1994), *Understanding supplier involvement in their customer's product development*. Thesis, University of Cincinnati.
- HAUSER, D. AND BOATENG, G. (1993), Tools, processes and users. *Proceedings of the Fifth International Forum on Design Management Research and Education: "Design Perspectives: Tools, Processes and Users"*. MIT, July 14-16.
- HATZICHRONOGLU, T. (1997), *Classification of high tech sectors and products*, OECD.
- HAYES, R.H., AND ABERNATHY, W. (1980), Managing our way to economic decline. *Harvard Business Review*, vol. 58, July-August, pp. 67-77.
- HOLLAND, R. (1993), The development of design methodologies based on the soft systems approach to problem definition. *Proceedings of the Fifth International Forum on Design Management Research and Education: "Design Perspectives: Tools, Processes and Users"*. MIT, July 14-16.
- JENSEN, B. AND HARMSSEN, H. (2000), Implementation of success factors in new product development – the missing links? *European Journal of Innovation Management*, vol. 4, issue 1.
- JONES, R.P., (1998), Management, technology, and what's next. *International Journal of Technology Management*, vol. 16, 1/2/3.
- JONES, T., COOPER, R. AND WATERS, H. (1995), Communication between functions in multi-disciplinary new product development: an examination of the lines of information flow perceived to exist in three UK companies. *Proceedings of the European Academy of Design Conference: "Design Interface"*, April 11-13.
- JONES, T. AND FEARIS, P. (1995), Rapid product development: theory and practice. *Proceedings of the European Academy of Design Conference: "Design Interface"*, April 11-13.



- KOTLER, P. AND DUBOIS, B. (1997), *Marketing Management*, 9<sup>ème</sup> édition. Publi-Union.
- KREHBIEL, J. JR. (1993), Finding a better way to develop products. *Machine Design*, March 12, p. 90.
- LAURENT, S. (1999), *Chronologie du design, guide culturel*. Flammarion. Collection Tout l'Art Encyclopédie.
- LEMENS, A. (1994), Le marché du design en France. *Proceedings of the Sixth International Forum on Design Management*. Paris, June 1-3.
- LE SAINT-GRANT, F. (1992), Performance evaluation: all the answers?. *Management Accounting*, April, vol. 70, issue 4.
- LOOSSCHILDER, G. (1994), Consumer research to support product design decisions. *Proceedings of the Sixth International Forum on Design Management*. Paris, June 1-3.
- LOOSSCHILDER, G. (1995), Concept testing of product design proposals using computer-aided design in the earlier stages of product development. *Proceedings of the European Academy of Design Conference: "Design Interface"*, April 11-13.
- MACINNIS, M. AND HESLOP, L.A. (1990), Market planning in a high-tech environment. *Industrial Marketing Management*, 19, pp. 107-116.
- MAIDIQUE, M.A. AND ZIRGER, B.J. (1984), A study of success and failure in product innovation: the case of the US electronics industry. *IEEE, Transactions on Engineering Management*, vol.EM-31, 4, pp. 192-203.
- MALLICK, D.N., FITZSIMMONS, J.A. AND KOUVELIS, P. (1993), Defining product design: a managerial perspective. *Proceedings of the Fifth International Forum on Design Management Research and Education: "Design Perspectives: Tools, Processes and Users"*. MIT, July 14-16.
- MATHER, H. (1992), Design for logistics (DFL), the next challenge for designers. *Production and Inventory Management Journal*, first quarter, vol. 33, pp. 7-10.
- MC DERMOTT, C.M. AND STOCK, G.N. (1994), The use of common parts and designs in high-tech industries: a strategic approach. *Production and Inventory Management Journal*, third quarter, pp. 65-69.
- MELEWAR, T.C. AND SAUNDERS, J. (2000), Global corporate visual identity systems: using an extended marketing mix. *European Journal of Marketing*, vol. 34, No5/6, pp. 538-550.
- MILES, R.E., AND SNOW, C.C. (1978), *Organisational strategy, structure and process*. McGraw-Hill.

- MILLER, E. (1999 a), Visualisation tools for PDM. *Computer-Aided Engineering*, vol. 18, issue 3.
- MILLER, E. (1999 b), We've come a long way.... *Computer-Aided Engineering*, vol. 18, issue 10.
- MILLIER, P. (1989), *Le marketing des produits high tech, outils d'analyse*. Editions d'organisation.
- MILLIER, P. (1997), *Stratégie et marketing de l'innovation technologique*. Dunod.
- MONCK, C.S.P., P.R. QUINTAS, R.B. PORTER, D.J. STOREY AND P. WYNARCZYK (1988), *Science parks and the growth of high technology firms*. Croom Helm.
- MORIARTY, R.T. AND T.J. KOSNIK (1989), High tech marketing: concepts, continuity and change. *Sloan Management Review*, Summer, pp. 7-17.
- OLSON, E.M. (1993), Perceptual differences in interdependence, conflict, and conflict resolution between design and other functions involved in new product development. *Proceedings of the Fifth International Forum on Design Management Research and Education: "Design Perspectives: Tools, Processes and Users"*. MIT, July 14-16.
- PESKIN, M.I. AND ADIS, W. (1993), Concurrency: the new method for quickly bringing new products to market. *Review of Business*, vol. 15, 1, Summer/Fall, pp. 22-27.
- PHILLIPS, S.E. AND McDONNELL, J.T. (1999), Empowering the design team: a multimedia design resource to facilitate the capture, retention and reuse of knowledge acquired during product development in *Managing new product innovation*. Jerrard, B., Newport R. and Trueman M. Taylor and Francis.
- PLATT, A. AND WARWICK, S. (1995), Review of soft systems methodology. *Industrial Management and Data Systems*, vol. 95, issue 4.
- PRESS, M. (1995), It's research, Jim... *Co-design Journal*, 1<sup>st</sup> quarter, vol.2.
- PRICE, R. (1996), Technology and strategic advantage. *California Management Review*, Summer.
- PORTER, M.E. (1990), *Competitive advantage of nations*. The Free Press.
- PORTER, M.E. (1999), *La concurrence selon Porter*. Village Mondial.
- PORTER, M.E. AND MILLAR, V.E. (1999), Comment l'information vous confère un avantage concurrentiel, in *La concurrence selon Porter*, pp. 83-105. Village Mondial.
- PORTER, M.E. AND VAN DER LINDE, C. (1995), Green and competitive, ending the stalemate. *Havard Business Review*, Sept.-Oct., pp. 120-134.

- POTTER, S. (1992), Studying sensitive issues: using a sample survey in design management research. *Design Management Journal*, Fall, pp. 35-39.
- RAGSDALE, W. (2000), Engineering a paradigm shift? An holistic approach to organisational change management. *Journal of Organizational Change Management*, vol. 13, issue 2.
- REVAT, R. (1997), La place du consommateur dans le développement de nouveaux produits : le cas Salomon. *Gestion 2000*, Sept.-Oct.
- RICHARDSON, A. (1995), Design and business: what's the point. *Proceedings of the 7<sup>th</sup> International Forum on Design Management Research and Education, The Design Management Institute, "Connecting Value"*. Stanford University, July 9-12.
- ROBERTS, E.B. (1992), The success of high-technology firms: early technological and marketing influences. *Interfaces*, July-August, pp. 3-12.
- ROCHE, L. AND GRANGE, T. (1999), *Innovation et Technologie*. Maxima.
- ROCHFORD, L. AND WOTRUBA, T.R. (1993), New product development under changing economic conditions. *Journal of Business and Industrial Marketing*, vol. 8, pp. 4-12.
- ROY, R. AND POTTER, S. (1990), Managing design projects in small and medium-sized firms. *Technology Analysis and Strategic Management*, vol. 2, No 3, pp. 321-336.
- ROY, R., POTTER, S. AND RIEDEL, J.C.K.H. (1999), *The long-term benefits of investment in product design and innovation in Managing new product innovation*. Jerrard, B., Newport R. and Trueman M. Taylor and Francis.
- SAKAKIBARA, K., DUMAS, A. AND WATANABE, S. (1993), The new product trajectory: the Japanese context of product innovation. *Proceedings of the Fifth International Forum on Design Management Research and Education: "Design Perspectives: Tools, Processes and Users"*. MIT, July 14-16.
- SCHULMANN, D. (1991), *Le design industriel*. Presses Universitaires de France.
- SEGUIER, S. (2000), La veille technologique devient primordiale. *Bretagne Economique*, No 122, June.
- SEN GUPTA, S.R. (1994), *L'art de la marque ou les dix commandements du design stratégique*. Editions Udjal Arts.



- SETHIA, N.K. (1994), Redesigning TQM: quality leadership design. *Proceedings of the Sixth International Forum on Design Management*. Paris, June 1-3.
- SHANKLIN, W.L., AND RYANS, J.K. JR. (1984), *Marketing high technology*. Lexington.
- SMITH, P.G. AND REINERTSEN, D.G. (1991), *Developing products in half the time*. Van Nostrand Reinhold.
- SORRELL, J. (1995), *The secret of design effectiveness*. Newell and Sorrell.
- SOUDER, W.E. (1981), Disharmony between R&D and marketing. *Industrial Marketing Management*, 10, pp. 67-73.
- STALK, G. AND HOUT, T. (1992), *Competing against time*. The Free Press.
- SURESH BABU, T.K. (1995), Design and manufacturing criteria for successful product development. *Industrial Engineering Journal*, November, pp. 5-9.
- TABRIZI, B. N. (1994), *Accelerating product development*. Thesis, Stanford University.
- TAKENCHI, H. AND NONAKA, I., The new new product development game. *Harvard Business Review*, Jan.-Feb., pp. 137-146.
- TATIKONDA, M.V. (1994), Design for assembly: a critical methodology for product reengineering and new product development. *Production and Inventory Management Journal*, first quarter, pp. 31-38.
- TEMPLE, S. (1994), Thought made visible – the value of sketching. *Co-Design Journal*, section 1, Oct.-Dec.
- THÉRIN, F. (1996), Créer une orientation marketing dans les entreprises high-tech. *Les Cahiers du Management Technologique*, 18, Sept./Dec.
- THÖLKE, J. (1994), Product features in new product planning: an interactive process between market and technology. *Proceedings of the Sixth International Forum on Design Management*. Paris, June 1-3.
- TISSIER-DESBORDES, E. AND FIALHO, M. (1994), Chaînes de valeur et stratégie design. *Proceedings of the Sixth International Forum on Design Management*. Paris, June 1-3.
- TOPALIAN, A. (1994), Getting to grips with the 'design dimension' of quality improvement programmes. *Proceedings of the Sixth International Forum on Design Management*. Paris, June 1-3.

- TRAYNOR, K. AND TRAYNOR, S.C. (1989), Marketing approaches used by high tech firms. *Industrial Marketing Management*, 18, pp. 281-287.
- TRUEMAN, M. (1998), Managing innovation by design – how a new design typology may facilitate the product development process in industrial companies and provide a competitive advantage. *The European Journal of Innovation Management*, vol.1, issue 1.
- URBAN, G.L. AND HAUSER, J.R. (1993), *Design and marketing of new products*. Prentice Hall.
- VAKOLA, M. AND REZGUI, Y. (2000), Critique of existing business process re-engineering methodologies: the development and implementation of a new methodology. *Business Process Management Journal*, vol. 6, issue 3.
- VAN REKOM, J. (1997), Deriving an operational measure of corporate identity. *European Journal of Marketing*, vol. 31, No 5/6, pp. 419-422.
- VIARDOT, E. (1992), *Le marketing de la high tech*. Publi Union.
- VIARDOT, E. (1994), Le département marketing dans les entreprises de haute technologie. *Revue Française de Gestion*, pp. 15-22, June/Aug.
- VOGEL, B.L. (1993), Concept development for high-technology and medical products. *Design Management Journal*, Fall, pp. 43-54.
- WALKER, D. (1993), The soup, the bowl, and the place at the table. *Design Management Journal*, Fall, pp. 10-22.
- WALSH, V., ROY, R., BRUCE, M. AND POTTER, S. (1992), *Winning by design*. Blackwell Business.
- WHEELWRIGHT, S.C. AND CLARK, K.B. (1992), Creating project plans to focus product development. *Harvard Business Review*, March-April, pp. 70-82.
- WHITNEY, D.E. (1988), Manufacturing by design. *Harvard Business Review*, July-Aug., pp. 83-90.
- WILSON, E. (1993), Maximizing designers' impact on market success through product definition. *Design Management Journal*, Fall, pp. 62-68.
- WOOLEY, M. (1999), *Putting practice into practice: assimilating design into the corporate culture in Managing new product innovation*. Jerrard, B., Newport R. and Trueman M. Taylor and Francis.

## **APPENDIX ONE – IBT 5 AND IBT 10**

**Examples of products developed by Wandel & Goltermann France (ISDN testers)**



IBT 5



IBT 10

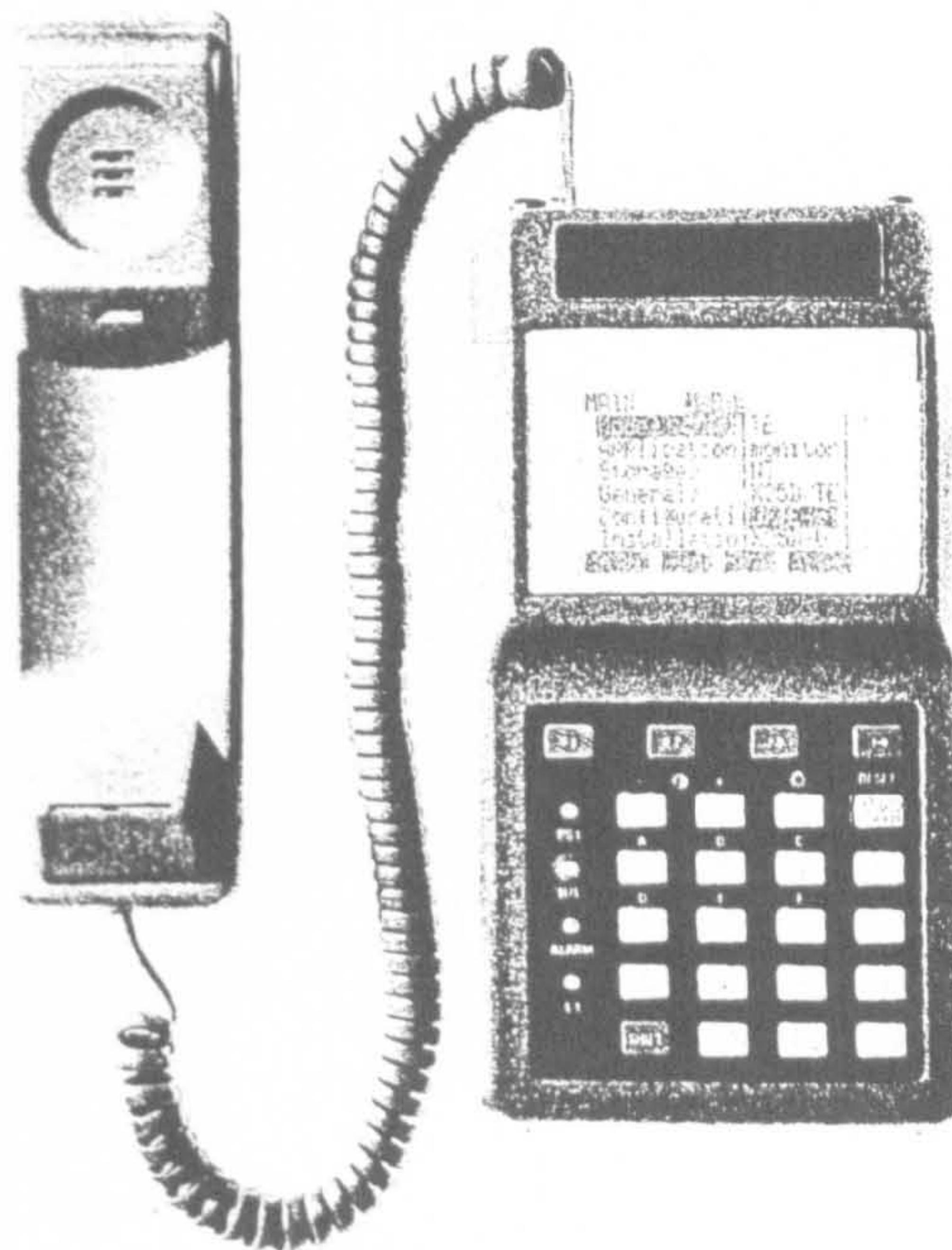

## **APPENDIX TWO – COVER LETTER AND QUESTIONNAIRE 1**

**Cover letter and questionnaire (translated from the French version) used for the exploratory quantitative stage.**

Rennes,  
October 6<sup>n</sup>, 1998

Dear Sir or Madam,

Please find enclosed a questionnaire concerning a doctoral survey relating to the new product development<sup>1</sup>. The final objective is to make a diagnosis of the methods and organisational structures implemented in the high tech industries operating in France and to eventually gain deeper knowledge about the French industrial sectors.

I would be very grateful if you could take about twenty minutes to fill in this document or to pass it to the appropriate person in your organisation. Please, send this questionnaire back by fax or mail before November 15th, 1998 to:

**Laurence RIOCHE**  
**ESC Rennes**  
**2, rue Robert d'Arbrissel**  
**35065 Rennes Cedex**  
**Tel.: 02.99.54.63.32 - Fax: 02.99.33.08.24**

Your answers must be as spontaneous as possible. Indications are provided to complete each question. In case of doubt, or if the question does not apply to your company (for instance, when it refers to subsidiaries), please leave the question blank. If you wish to complete your answers, there is a section at the end of the questionnaire to collect your comments.

**If you so wish, you can receive the final results of the survey. In that case, please give your full direction at the end of the questionnaire.**

Thank you in advance for your contribution to the present research.

Yours faithfully,

**Laurence Rioche**  
**Co-ordinator of the New Technologies Option.**

---

<sup>1</sup> From concept and feasibility studies to final launch on the market.



October 1998

## **New product development\* in high tech companies located in France**

### **QUESTIONNAIRE**

◆  
**We guarantee the anonymity of your answers**  
◆

In conformity with article 27 of regulation n° 78-17 of January 6th, 1978 concerning data processing and computer files, filling in this questionnaire is optional. Information that will be collected will only be used for statistical purposes and will be limited to an analysis by the survey's author. Data collected is accessible according to the conditions set by article 27 of the above mentioned regulation.

If you need more information about this survey please contact:

**Laurence RIOCHE**

**Tel. : (+33) (0)2.99.54.63.32**

**e-mail : laurence.rioche@esc-rennes.fr**

\*: the notion of product development includes the whole process from upstream market research to product launch on the market.

**1. RESPONDENT'S DETAILS**

**1) What is your position in the company?**

- |                                                               |                                                         |                          |                          |
|---------------------------------------------------------------|---------------------------------------------------------|--------------------------|--------------------------|
| <input type="checkbox"/> Chairman                             | <input type="checkbox"/> Production Manager             | <input type="checkbox"/> | <input type="checkbox"/> |
| <input type="checkbox"/> Managing Director                    | <input type="checkbox"/> R&D Manager                    |                          |                          |
| <input type="checkbox"/> Administrative and Financial Manager | <input type="checkbox"/> Product Manager                |                          |                          |
| <input type="checkbox"/> Manager of Human Resources           | <input type="checkbox"/> Project Manager                |                          |                          |
| <input type="checkbox"/> Marketing Manager                    | <input type="checkbox"/> Other (please specify) : ..... |                          |                          |

**2) For how long have you been working in the company ?**

For [\_\_\_\_\_] years and / or [\_\_\_\_\_] months.

**2. THE COMPANY**

**1) Please specify: - APE code: [ ][ ][ ][ ]**    
**- year of creation: [\_\_\_\_\_]**

**2) Is it a subsidiary? (More than 50% of company's shares are held by a group)**

Yes  No

**3) Please specify the company's and, if applicable, the group's net results and turnover for 1997:**

	Net results 1997	Turnover 1997	<input type="checkbox"/>	<input type="checkbox"/>
Company	FF	FF	<input type="checkbox"/>	<input type="checkbox"/>
Group	FF	FF	<input type="checkbox"/>	<input type="checkbox"/>

**4) What is the origin of the capital?**

- Principally French (>50%)    
 Principally foreign (>50%) / Which nationality? .....

Codification  
Do not fill in

5) How many people are employed in the company and, if applicable, by the group ?

[ ] people employed in the company.

[ ] people employed by the group.

6) How many people (including executives) are employed in your company / subsidiary for the following functions?

	Total number of people employed	Executives
Marketing	pers.	pers.
Production	pers.	pers.
R&D	pers.	pers.

7) If the company is a subsidiary, how many people (including executives) are employed by the group for the following functions?

	Total number of people employed	Executives
Marketing	pers.	pers.
Production	pers.	pers.
R&D	pers.	pers.

8) Does your company have a production site ?

Yes  No

- If 'no', and if the company is a subsidiary, does the group have a production site?  Yes  No

9) Do you have a quality certification?

Yes  In progress  No

If 'yes' or 'in progress', for which norms? (ex. ISO 9001, 9002, etc.)

.....



**3. RESEARCH AND DEVELOPMENT / ORGANISATIONAL FACTORS**

**1) Who is in charge of Research and Development in your company?**

(1 or more answers )

- There is no R&D.
- There is an R&D Department for the whole group.
- There is an R&D Department for the company/subsidiary.
- R&D is sub-contracted or bought in.
- R&D is managed through external research centers.
- Other(s) (specify) : .....
- .....
- .....
- .....

**2) How are product development projects managed?**

- On the basis of a department-based organisation (ex. : design, tests, production)
- Through a multidisciplinary, team-based organisation (ex. : a person from the marketing department + a person from the production department + a person from the R&D department); each team being responsible for the whole product development process.
- Through a multidisciplinary team-based organisation; each team successively intervening in the development of the project.
- Other (please specify) : .....
- .....
- .....

3) If several departments or teams are involved, who is responsible for ensuring the coordination at the various stages?

- A project leader who supervises the whole development process;
- The upstream department or team transmits information to the following service or team;
- A person within each department or team is responsible for transmitting information to the following department or team;
- Other (please specify) : .....    
 .....    
 .....

4) In your company, how many people usually participate in the new product development process as a whole?

[ \_\_\_\_\_ ] people.

If a subsidiary, please specify if this number includes group employees:

- Yes  No

5) What percentage of total turnover did R&D investment represent in 1997?

	Company: R&D ----- % Total turnover	Group: R&D ----- % Total turnover
1997	%	%

6) What is, in your opinion, the importance of the links between R&D and other company departments?

	Not important at all			Extremely important			
	1	2	3	4	5		
- Board of Management	<input type="checkbox"/>	<input type="checkbox"/>	<input type="checkbox"/>	<input type="checkbox"/>	<input type="checkbox"/>	<input type="checkbox"/>	<input type="checkbox"/>
- Administration	<input type="checkbox"/>	<input type="checkbox"/>	<input type="checkbox"/>	<input type="checkbox"/>	<input type="checkbox"/>	<input type="checkbox"/>	<input type="checkbox"/>
- Production engineering	<input type="checkbox"/>	<input type="checkbox"/>	<input type="checkbox"/>	<input type="checkbox"/>	<input type="checkbox"/>	<input type="checkbox"/>	<input type="checkbox"/>
- Design	<input type="checkbox"/>	<input type="checkbox"/>	<input type="checkbox"/>	<input type="checkbox"/>	<input type="checkbox"/>	<input type="checkbox"/>	<input type="checkbox"/>
- Marketing	<input type="checkbox"/>	<input type="checkbox"/>	<input type="checkbox"/>	<input type="checkbox"/>	<input type="checkbox"/>	<input type="checkbox"/>	<input type="checkbox"/>
- Sales	<input type="checkbox"/>	<input type="checkbox"/>	<input type="checkbox"/>	<input type="checkbox"/>	<input type="checkbox"/>	<input type="checkbox"/>	<input type="checkbox"/>
- Production	<input type="checkbox"/>	<input type="checkbox"/>	<input type="checkbox"/>	<input type="checkbox"/>	<input type="checkbox"/>	<input type="checkbox"/>	<input type="checkbox"/>
- Finance	<input type="checkbox"/>	<input type="checkbox"/>	<input type="checkbox"/>	<input type="checkbox"/>	<input type="checkbox"/>	<input type="checkbox"/>	<input type="checkbox"/>
- Quality	<input type="checkbox"/>	<input type="checkbox"/>	<input type="checkbox"/>	<input type="checkbox"/>	<input type="checkbox"/>	<input type="checkbox"/>	<input type="checkbox"/>
- Other(s) (specify) : .....	<input type="checkbox"/>	<input type="checkbox"/>	<input type="checkbox"/>	<input type="checkbox"/>	<input type="checkbox"/>	<input type="checkbox"/>	<input type="checkbox"/>
.....	<input type="checkbox"/>	<input type="checkbox"/>	<input type="checkbox"/>	<input type="checkbox"/>	<input type="checkbox"/>	<input type="checkbox"/>	<input type="checkbox"/>
.....	<input type="checkbox"/>	<input type="checkbox"/>	<input type="checkbox"/>	<input type="checkbox"/>	<input type="checkbox"/>	<input type="checkbox"/>	<input type="checkbox"/>

7) What is the nature of R&D / production links, if they exist?

(1 or more answers)

<input type="checkbox"/> Meetings -What is the average frequency?			<input type="checkbox"/>	<input type="checkbox"/>
<input type="checkbox"/> Less than 2-3 times per year	<input type="checkbox"/> About every 2-3 months		<input type="checkbox"/>	<input type="checkbox"/>
<input type="checkbox"/> About once a month	<input type="checkbox"/> About 2-3 times per month		<input type="checkbox"/>	<input type="checkbox"/>
<input type="checkbox"/> About once a week	<input type="checkbox"/> More than once a week			
<input type="checkbox"/> Electronic data exchange			<input type="checkbox"/>	<input type="checkbox"/>
<input type="checkbox"/> Written communication			<input type="checkbox"/>	<input type="checkbox"/>
<input type="checkbox"/> Multidisciplinary teams (teams made up of employees from different departments)			<input type="checkbox"/>	<input type="checkbox"/>
<input type="checkbox"/> Exchanges via a manager			<input type="checkbox"/>	<input type="checkbox"/>
<input type="checkbox"/> Informal exchanges			<input type="checkbox"/>	<input type="checkbox"/>
<input type="checkbox"/> Other(s) (please specify): .....			<input type="checkbox"/>	<input type="checkbox"/>
.....			<input type="checkbox"/>	<input type="checkbox"/>



8) What is the nature of R&D / marketing links, if they exist?

(1 or more answers)

Meetings -What is the average frequency?

Fewer than 2-3 times per year

About once a month

About once a week

About every 2-3 months

About 2-3 times per month

More than once a week

Electronic data exchange

Written communication

Multidisciplinary teams (teams made up of employees from different departments)

Exchanges via a manager

Informal exchanges

Other(s) (specify): .....

.....

9) What, in your opinion, in your company, is the importance of the links between the R&D Dept. and external partners?

Not important  
at all

Extremely  
important

1

2

3

4

5

- Suppliers

- Customers

- Sub-contractors

- Other(s) (please, specify) : .....

.....

.....

10) What is the nature of the links between the R&D Dept. and customers, if they exist?

(1 or more answers)

- Direct contact between executives or managers
- Formal meetings
- Electronic data exchange
- Written communication
- Multidisciplinary teams (teams involving customers throughout the entire project development))
- Prior identification of customers' requirements
- Exchanges through the salesforce
- Exchanges through the marketing department
- Exchanges through the after sales service
- Panels or formalised, regular data collection concerning customers' needs
- Miscellaneous informal contacts
- Other(s) (please, specify) : .....
- .....

11) What is the approximate percentage of customers with whom you directly cooperate for new product development?

[ ] %

12) What is the importance of external partners in R&D decisions?

	Not important at all			Extremely important			
	1	2	3	4	5		
- Suppliers	[ ]	[ ]	[ ]	[ ]	[ ]	<input type="checkbox"/>	<input type="checkbox"/>
- Customers	[ ]	[ ]	[ ]	[ ]	[ ]	<input type="checkbox"/>	<input type="checkbox"/>
- Sub-contractors	[ ]	[ ]	[ ]	[ ]	[ ]	<input type="checkbox"/>	<input type="checkbox"/>
- Other(s) (please, specify): .....	[ ]	[ ]	[ ]	[ ]	[ ]	<input type="checkbox"/>	<input type="checkbox"/>
.....	[ ]	[ ]	[ ]	[ ]	[ ]	<input type="checkbox"/>	<input type="checkbox"/>
.....	[ ]	[ ]	[ ]	[ ]	[ ]	<input type="checkbox"/>	<input type="checkbox"/>

**13) What is the importance of the other departments of the company in R&D decisions?**

	Not important at all			Extremely important			
	1	2	3	4	5		
- Board of Management	<input type="checkbox"/>	<input type="checkbox"/>	<input type="checkbox"/>	<input type="checkbox"/>	<input type="checkbox"/>	<input type="checkbox"/>	<input type="checkbox"/>
- Administration	<input type="checkbox"/>	<input type="checkbox"/>	<input type="checkbox"/>	<input type="checkbox"/>	<input type="checkbox"/>	<input type="checkbox"/>	<input type="checkbox"/>
- Production engineering	<input type="checkbox"/>	<input type="checkbox"/>	<input type="checkbox"/>	<input type="checkbox"/>	<input type="checkbox"/>	<input type="checkbox"/>	<input type="checkbox"/>
- Design	<input type="checkbox"/>	<input type="checkbox"/>	<input type="checkbox"/>	<input type="checkbox"/>	<input type="checkbox"/>	<input type="checkbox"/>	<input type="checkbox"/>
- Marketing	<input type="checkbox"/>	<input type="checkbox"/>	<input type="checkbox"/>	<input type="checkbox"/>	<input type="checkbox"/>	<input type="checkbox"/>	<input type="checkbox"/>
- Sales	<input type="checkbox"/>	<input type="checkbox"/>	<input type="checkbox"/>	<input type="checkbox"/>	<input type="checkbox"/>	<input type="checkbox"/>	<input type="checkbox"/>
- Production	<input type="checkbox"/>	<input type="checkbox"/>	<input type="checkbox"/>	<input type="checkbox"/>	<input type="checkbox"/>	<input type="checkbox"/>	<input type="checkbox"/>
- Finance	<input type="checkbox"/>	<input type="checkbox"/>	<input type="checkbox"/>	<input type="checkbox"/>	<input type="checkbox"/>	<input type="checkbox"/>	<input type="checkbox"/>
- Quality	<input type="checkbox"/>	<input type="checkbox"/>	<input type="checkbox"/>	<input type="checkbox"/>	<input type="checkbox"/>	<input type="checkbox"/>	<input type="checkbox"/>
- Other(s) (please, specify): .....	<input type="checkbox"/>	<input type="checkbox"/>	<input type="checkbox"/>	<input type="checkbox"/>	<input type="checkbox"/>	<input type="checkbox"/>	<input type="checkbox"/>
.....	<input type="checkbox"/>	<input type="checkbox"/>	<input type="checkbox"/>	<input type="checkbox"/>	<input type="checkbox"/>	<input type="checkbox"/>	<input type="checkbox"/>

**14) What is, in your opinion, the importance of the following sources of innovation in your company?**

	Not important at all			Extremely important			
	1	2	3	4	5		
- Specialised press/trade fairs	<input type="checkbox"/>	<input type="checkbox"/>	<input type="checkbox"/>	<input type="checkbox"/>	<input type="checkbox"/>	<input type="checkbox"/>	<input type="checkbox"/>
- Innovations by competitors	<input type="checkbox"/>	<input type="checkbox"/>	<input type="checkbox"/>	<input type="checkbox"/>	<input type="checkbox"/>	<input type="checkbox"/>	<input type="checkbox"/>
- Exchanges with suppliers	<input type="checkbox"/>	<input type="checkbox"/>	<input type="checkbox"/>	<input type="checkbox"/>	<input type="checkbox"/>	<input type="checkbox"/>	<input type="checkbox"/>
- Exchanges with customers	<input type="checkbox"/>	<input type="checkbox"/>	<input type="checkbox"/>	<input type="checkbox"/>	<input type="checkbox"/>	<input type="checkbox"/>	<input type="checkbox"/>
- Exchanges with subcontractors	<input type="checkbox"/>	<input type="checkbox"/>	<input type="checkbox"/>	<input type="checkbox"/>	<input type="checkbox"/>	<input type="checkbox"/>	<input type="checkbox"/>
- Contacts with research centers	<input type="checkbox"/>	<input type="checkbox"/>	<input type="checkbox"/>	<input type="checkbox"/>	<input type="checkbox"/>	<input type="checkbox"/>	<input type="checkbox"/>
- Suggestions from other departments of the company	<input type="checkbox"/>	<input type="checkbox"/>	<input type="checkbox"/>	<input type="checkbox"/>	<input type="checkbox"/>	<input type="checkbox"/>	<input type="checkbox"/>
- Information from the sales force	<input type="checkbox"/>	<input type="checkbox"/>	<input type="checkbox"/>	<input type="checkbox"/>	<input type="checkbox"/>	<input type="checkbox"/>	<input type="checkbox"/>
- Intuition on the part of managers	<input type="checkbox"/>	<input type="checkbox"/>	<input type="checkbox"/>	<input type="checkbox"/>	<input type="checkbox"/>	<input type="checkbox"/>	<input type="checkbox"/>
- Other(s) (please, specify) : .....	<input type="checkbox"/>	<input type="checkbox"/>	<input type="checkbox"/>	<input type="checkbox"/>	<input type="checkbox"/>	<input type="checkbox"/>	<input type="checkbox"/>
.....	<input type="checkbox"/>	<input type="checkbox"/>	<input type="checkbox"/>	<input type="checkbox"/>	<input type="checkbox"/>	<input type="checkbox"/>	<input type="checkbox"/>



**4. MARKETING AND NEW PRODUCT DEVELOPMENT**

**1) What is, in your company, the percentage of customised products and the percentage of standardised products?**

- Customised products:	[ ] %	<input type="checkbox"/>	<input type="checkbox"/>
- Standardised products:	[ ] %	<input type="checkbox"/>	<input type="checkbox"/>
	-----		
	$\Sigma = 100 \%$		

**2) Do you usually seek advice from your customers before launching the final product?**

Never	Sometimes	Always		
1	2	3		
[ ]	[ ]	[ ]	<input type="checkbox"/>	<input type="checkbox"/>

**- If 'sometimes' or 'always', do you generally test one/several prototypes before launching the final product?**

Never	Sometimes	Always		
1	2	3		
[ ]	[ ]	[ ]	<input type="checkbox"/>	<input type="checkbox"/>

**3) Are there, in your company, formalised procedures for obtaining field information (sales force reports, electronic data, etc.)?**

<input type="checkbox"/> Yes	<input type="checkbox"/> No	<input type="checkbox"/>	<input type="checkbox"/>
------------------------------	-----------------------------	--------------------------	--------------------------

**4) Are there formalised procedures for obtaining information from the after sales Department?**

<input type="checkbox"/> Yes	<input type="checkbox"/> No	<input type="checkbox"/>	<input type="checkbox"/>
------------------------------	-----------------------------	--------------------------	--------------------------

5) Is new product development in your company formalised by written procedures?

Not at all 1	Partly 2	Totally 3		
[ ]	[ ]	[ ]		[ ] [ ]

6) When developing new products, is your objective:

<i>At the product level :</i>	Not important at all					Extremely important	
	1	2	3	4	5		
- A completely innovative product?	[ ]	[ ]	[ ]	[ ]	[ ]	[ ]	[ ]
- A high tech product?	[ ]	[ ]	[ ]	[ ]	[ ]	[ ]	[ ]
- A product adapted to customers' requirements?	[ ]	[ ]	[ ]	[ ]	[ ]	[ ]	[ ]
- A product which is easy to use?	[ ]	[ ]	[ ]	[ ]	[ ]	[ ]	[ ]
- An aesthetically pleasing product?	[ ]	[ ]	[ ]	[ ]	[ ]	[ ]	[ ]
- A reliable product?	[ ]	[ ]	[ ]	[ ]	[ ]	[ ]	[ ]
- To develop a global solution?	[ ]	[ ]	[ ]	[ ]	[ ]	[ ]	[ ]
- To develop a wide range?	[ ]	[ ]	[ ]	[ ]	[ ]	[ ]	[ ]
- A product which is easy to manufacture?	[ ]	[ ]	[ ]	[ ]	[ ]	[ ]	[ ]
- Other(s) (please specify): .....	[ ]	[ ]	[ ]	[ ]	[ ]	[ ]	[ ]
.....	[ ]	[ ]	[ ]	[ ]	[ ]	[ ]	[ ]

<i>At the level of costs:</i>	Not important at all					Extremely important	
	1	2	3	4	5		
- To respect the budget allocated?	[ ]	[ ]	[ ]	[ ]	[ ]	[ ]	[ ]
- To reduce development costs a maximum?	[ ]	[ ]	[ ]	[ ]	[ ]	[ ]	[ ]
- To reduce manufacturing costs a maximum?	[ ]	[ ]	[ ]	[ ]	[ ]	[ ]	[ ]
- To reduce maintenance costs a maximum?	[ ]	[ ]	[ ]	[ ]	[ ]	[ ]	[ ]
- To achieve a competitive selling price?	[ ]	[ ]	[ ]	[ ]	[ ]	[ ]	[ ]
- Other(s) (please specify): .....	[ ]	[ ]	[ ]	[ ]	[ ]	[ ]	[ ]
.....	[ ]	[ ]	[ ]	[ ]	[ ]	[ ]	[ ]

At the level of norms:

	Not important at all					Extremely important	
	1	2	3	4	5		
- To respect quality procedures?	<input type="checkbox"/>	<input type="checkbox"/>	<input type="checkbox"/>	<input type="checkbox"/>	<input type="checkbox"/>	<input type="checkbox"/>	<input type="checkbox"/>
- To achieve a high level of quality?	<input type="checkbox"/>	<input type="checkbox"/>	<input type="checkbox"/>	<input type="checkbox"/>	<input type="checkbox"/>	<input type="checkbox"/>	<input type="checkbox"/>
- To respect the ecological norms?	<input type="checkbox"/>	<input type="checkbox"/>	<input type="checkbox"/>	<input type="checkbox"/>	<input type="checkbox"/>	<input type="checkbox"/>	<input type="checkbox"/>
- To achieve a high level of safety norms?	<input type="checkbox"/>	<input type="checkbox"/>	<input type="checkbox"/>	<input type="checkbox"/>	<input type="checkbox"/>	<input type="checkbox"/>	<input type="checkbox"/>
- Other(s) (please specify) : .....	<input type="checkbox"/>	<input type="checkbox"/>	<input type="checkbox"/>	<input type="checkbox"/>	<input type="checkbox"/>	<input type="checkbox"/>	<input type="checkbox"/>
.....	<input type="checkbox"/>	<input type="checkbox"/>	<input type="checkbox"/>	<input type="checkbox"/>	<input type="checkbox"/>	<input type="checkbox"/>	<input type="checkbox"/>
.....	<input type="checkbox"/>	<input type="checkbox"/>	<input type="checkbox"/>	<input type="checkbox"/>	<input type="checkbox"/>	<input type="checkbox"/>	<input type="checkbox"/>

7) During the whole product development and launching process, what is the importance given to the following stages, in terms of financial investments?

	Not important at all					Extremely important	
	1	2	3	4	5		
- R&D	<input type="checkbox"/>	<input type="checkbox"/>	<input type="checkbox"/>	<input type="checkbox"/>	<input type="checkbox"/>	<input type="checkbox"/>	<input type="checkbox"/>
- Market research	<input type="checkbox"/>	<input type="checkbox"/>	<input type="checkbox"/>	<input type="checkbox"/>	<input type="checkbox"/>	<input type="checkbox"/>	<input type="checkbox"/>
- Developing prototypes	<input type="checkbox"/>	<input type="checkbox"/>	<input type="checkbox"/>	<input type="checkbox"/>	<input type="checkbox"/>	<input type="checkbox"/>	<input type="checkbox"/>
- Developing the production process	<input type="checkbox"/>	<input type="checkbox"/>	<input type="checkbox"/>	<input type="checkbox"/>	<input type="checkbox"/>	<input type="checkbox"/>	<input type="checkbox"/>
- Engineering	<input type="checkbox"/>	<input type="checkbox"/>	<input type="checkbox"/>	<input type="checkbox"/>	<input type="checkbox"/>	<input type="checkbox"/>	<input type="checkbox"/>
- Quality procedures	<input type="checkbox"/>	<input type="checkbox"/>	<input type="checkbox"/>	<input type="checkbox"/>	<input type="checkbox"/>	<input type="checkbox"/>	<input type="checkbox"/>
- Administrative support	<input type="checkbox"/>	<input type="checkbox"/>	<input type="checkbox"/>	<input type="checkbox"/>	<input type="checkbox"/>	<input type="checkbox"/>	<input type="checkbox"/>
- Organising the sales force	<input type="checkbox"/>	<input type="checkbox"/>	<input type="checkbox"/>	<input type="checkbox"/>	<input type="checkbox"/>	<input type="checkbox"/>	<input type="checkbox"/>
- Advertising and commercial support (information literature, packaging, etc.)	<input type="checkbox"/>	<input type="checkbox"/>	<input type="checkbox"/>	<input type="checkbox"/>	<input type="checkbox"/>	<input type="checkbox"/>	<input type="checkbox"/>
- Other(s) (please specify): .....	<input type="checkbox"/>	<input type="checkbox"/>	<input type="checkbox"/>	<input type="checkbox"/>	<input type="checkbox"/>	<input type="checkbox"/>	<input type="checkbox"/>
.....	<input type="checkbox"/>	<input type="checkbox"/>	<input type="checkbox"/>	<input type="checkbox"/>	<input type="checkbox"/>	<input type="checkbox"/>	<input type="checkbox"/>
.....	<input type="checkbox"/>	<input type="checkbox"/>	<input type="checkbox"/>	<input type="checkbox"/>	<input type="checkbox"/>	<input type="checkbox"/>	<input type="checkbox"/>



8) According to which criteria do you decide to launch a new product?

	Not important at all					Extremely important	
	1	2	3	4	5		
- The product is technically ready	<input type="checkbox"/>	<input type="checkbox"/>	<input type="checkbox"/>	<input type="checkbox"/>	<input type="checkbox"/>	<input type="checkbox"/>	<input type="checkbox"/>
- The commercial support is ready	<input type="checkbox"/>	<input type="checkbox"/>	<input type="checkbox"/>	<input type="checkbox"/>	<input type="checkbox"/>	<input type="checkbox"/>	<input type="checkbox"/>
- The administrative support is ready	<input type="checkbox"/>	<input type="checkbox"/>	<input type="checkbox"/>	<input type="checkbox"/>	<input type="checkbox"/>	<input type="checkbox"/>	<input type="checkbox"/>
- Market research is positive	<input type="checkbox"/>	<input type="checkbox"/>	<input type="checkbox"/>	<input type="checkbox"/>	<input type="checkbox"/>	<input type="checkbox"/>	<input type="checkbox"/>
- The planned launch date is reached	<input type="checkbox"/>	<input type="checkbox"/>	<input type="checkbox"/>	<input type="checkbox"/>	<input type="checkbox"/>	<input type="checkbox"/>	<input type="checkbox"/>
- There is strong pressure from competitors	<input type="checkbox"/>	<input type="checkbox"/>	<input type="checkbox"/>	<input type="checkbox"/>	<input type="checkbox"/>	<input type="checkbox"/>	<input type="checkbox"/>
- There is an increasing demand from customers	<input type="checkbox"/>	<input type="checkbox"/>	<input type="checkbox"/>	<input type="checkbox"/>	<input type="checkbox"/>	<input type="checkbox"/>	<input type="checkbox"/>
- Other(s) (please specify): .....	<input type="checkbox"/>	<input type="checkbox"/>	<input type="checkbox"/>	<input type="checkbox"/>	<input type="checkbox"/>	<input type="checkbox"/>	<input type="checkbox"/>
.....	<input type="checkbox"/>	<input type="checkbox"/>	<input type="checkbox"/>	<input type="checkbox"/>	<input type="checkbox"/>	<input type="checkbox"/>	<input type="checkbox"/>
.....	<input type="checkbox"/>	<input type="checkbox"/>	<input type="checkbox"/>	<input type="checkbox"/>	<input type="checkbox"/>	<input type="checkbox"/>	<input type="checkbox"/>

9) What is the importance given to development deadlines?

- for launching a totally new product?

Not important at all				Extremely important		
1	2	3	4	5		
<input type="checkbox"/>	<input type="checkbox"/>	<input type="checkbox"/>	<input type="checkbox"/>	<input type="checkbox"/>	<input type="checkbox"/>	<input type="checkbox"/>

- for modifying/improving an existing product?

Not important at all				Extremely important		
1	2	3	4	5		
<input type="checkbox"/>	<input type="checkbox"/>	<input type="checkbox"/>	<input type="checkbox"/>	<input type="checkbox"/>	<input type="checkbox"/>	<input type="checkbox"/>

10) In the last three years (1995-98), do you think that you have shortened new product development deadlines in your company?

Not at all				Completely		
1	2	3	4	5		
<input type="checkbox"/>	<input type="checkbox"/>	<input type="checkbox"/>	<input type="checkbox"/>	<input type="checkbox"/>	<input type="checkbox"/>	<input type="checkbox"/>

11) What is the importance of the following, in your company, for reducing new product development delays?

	Not important at all		3	4	Extremely important			
	1	2			5			
- A formal process validating development step by step	<input type="checkbox"/>	<input type="checkbox"/>	<input type="checkbox"/>	<input type="checkbox"/>	<input type="checkbox"/>	<input type="checkbox"/>	<input type="checkbox"/>	<input type="checkbox"/>
- The implementation of upstream studies to reduce problems in the development stages	<input type="checkbox"/>	<input type="checkbox"/>	<input type="checkbox"/>	<input type="checkbox"/>	<input type="checkbox"/>	<input type="checkbox"/>	<input type="checkbox"/>	<input type="checkbox"/>
- Incentive bonuses for respecting deadlines	<input type="checkbox"/>	<input type="checkbox"/>	<input type="checkbox"/>	<input type="checkbox"/>	<input type="checkbox"/>	<input type="checkbox"/>	<input type="checkbox"/>	<input type="checkbox"/>
- Design methods to standardise the components	<input type="checkbox"/>	<input type="checkbox"/>	<input type="checkbox"/>	<input type="checkbox"/>	<input type="checkbox"/>	<input type="checkbox"/>	<input type="checkbox"/>	<input type="checkbox"/>
- A reduction in the number of prototypes	<input type="checkbox"/>	<input type="checkbox"/>	<input type="checkbox"/>	<input type="checkbox"/>	<input type="checkbox"/>	<input type="checkbox"/>	<input type="checkbox"/>	<input type="checkbox"/>
- The use of CAD	<input type="checkbox"/>	<input type="checkbox"/>	<input type="checkbox"/>	<input type="checkbox"/>	<input type="checkbox"/>	<input type="checkbox"/>	<input type="checkbox"/>	<input type="checkbox"/>
- Integrating suppliers in the development process	<input type="checkbox"/>	<input type="checkbox"/>	<input type="checkbox"/>	<input type="checkbox"/>	<input type="checkbox"/>	<input type="checkbox"/>	<input type="checkbox"/>	<input type="checkbox"/>
- Integrating customers in the development process	<input type="checkbox"/>	<input type="checkbox"/>	<input type="checkbox"/>	<input type="checkbox"/>	<input type="checkbox"/>	<input type="checkbox"/>	<input type="checkbox"/>	<input type="checkbox"/>
- Integrating sub-contractors in the development process	<input type="checkbox"/>	<input type="checkbox"/>	<input type="checkbox"/>	<input type="checkbox"/>	<input type="checkbox"/>	<input type="checkbox"/>	<input type="checkbox"/>	<input type="checkbox"/>
- Project management integrating all the departments concerned	<input type="checkbox"/>	<input type="checkbox"/>	<input type="checkbox"/>	<input type="checkbox"/>	<input type="checkbox"/>	<input type="checkbox"/>	<input type="checkbox"/>	<input type="checkbox"/>
- Specific training programmes	<input type="checkbox"/>	<input type="checkbox"/>	<input type="checkbox"/>	<input type="checkbox"/>	<input type="checkbox"/>	<input type="checkbox"/>	<input type="checkbox"/>	<input type="checkbox"/>
- Improving production equipment	<input type="checkbox"/>	<input type="checkbox"/>	<input type="checkbox"/>	<input type="checkbox"/>	<input type="checkbox"/>	<input type="checkbox"/>	<input type="checkbox"/>	<input type="checkbox"/>
- Developing the information system	<input type="checkbox"/>	<input type="checkbox"/>	<input type="checkbox"/>	<input type="checkbox"/>	<input type="checkbox"/>	<input type="checkbox"/>	<input type="checkbox"/>	<input type="checkbox"/>
- Collaboration between R&D and marketing	<input type="checkbox"/>	<input type="checkbox"/>	<input type="checkbox"/>	<input type="checkbox"/>	<input type="checkbox"/>	<input type="checkbox"/>	<input type="checkbox"/>	<input type="checkbox"/>
- Collaboration between R&D and production	<input type="checkbox"/>	<input type="checkbox"/>	<input type="checkbox"/>	<input type="checkbox"/>	<input type="checkbox"/>	<input type="checkbox"/>	<input type="checkbox"/>	<input type="checkbox"/>
- Collaboration between production and marketing	<input type="checkbox"/>	<input type="checkbox"/>	<input type="checkbox"/>	<input type="checkbox"/>	<input type="checkbox"/>	<input type="checkbox"/>	<input type="checkbox"/>	<input type="checkbox"/>
- Other(s) (please specify) : .....	<input type="checkbox"/>	<input type="checkbox"/>	<input type="checkbox"/>	<input type="checkbox"/>	<input type="checkbox"/>	<input type="checkbox"/>	<input type="checkbox"/>	<input type="checkbox"/>
.....	<input type="checkbox"/>	<input type="checkbox"/>	<input type="checkbox"/>	<input type="checkbox"/>	<input type="checkbox"/>	<input type="checkbox"/>	<input type="checkbox"/>	<input type="checkbox"/>
.....	<input type="checkbox"/>	<input type="checkbox"/>	<input type="checkbox"/>	<input type="checkbox"/>	<input type="checkbox"/>	<input type="checkbox"/>	<input type="checkbox"/>	<input type="checkbox"/>

**12) What is the nature of production/marketing links, if they exist?**

*(1 or more answers)*

Meetings -What is the average frequency?

Fewer than 2-3 times per year

About every 2-3 months

About once a month

About 2-3 times per month

About once a week

More than once a week

Electronic information exchange

Written communication

Multidisciplinary teams (teams integrating employees from different departments)

Exchanges via a manager

Informal exchanges

Other(s) (please specify): .....

.....

**13) Do you have in your company/group customers' services such as a free phone number or a hot line?     Yes                       No**

**14) In your company / subsidiary and, if applicable, in your group, do you think that marketing orientation is:**

	Not important at all				Extremely important		
	1	2	3	4	5		
- In the company:	<input type="checkbox"/>	<input type="checkbox"/>	<input type="checkbox"/>	<input type="checkbox"/>	<input type="checkbox"/>	<input type="checkbox"/>	<input type="checkbox"/>
- In the group:	<input type="checkbox"/>	<input type="checkbox"/>	<input type="checkbox"/>	<input type="checkbox"/>	<input type="checkbox"/>	<input type="checkbox"/>	<input type="checkbox"/>

**15) Do you think that marketing orientation should be developed?**

	Not at all				A great deal		
	1	2	3	4	5		
- In the company:	<input type="checkbox"/>	<input type="checkbox"/>	<input type="checkbox"/>	<input type="checkbox"/>	<input type="checkbox"/>	<input type="checkbox"/>	<input type="checkbox"/>
- In the group:	<input type="checkbox"/>	<input type="checkbox"/>	<input type="checkbox"/>	<input type="checkbox"/>	<input type="checkbox"/>	<input type="checkbox"/>	<input type="checkbox"/>



16) Has there been any marketing/commercial training in your company or group during the last 3 years?

Yes  No

If 'yes', who was involved, in your company/group?  
(1 or more answers)

People from the Production department

People from the R&D department

People from the Marketing department

The sales force

The executives

The managers

Other(s) (please specify): .....

17) What is the educational background of the people in charge of marketing in your company?

- Commercial background: [ ] %

- Technical background: [ ] %

- Other(s) (please specify): ..... [ ] %

-----  
 $\Sigma = 100\%$

**5. SUCCESS OF NEW PRODUCTS**

1) Can you give an estimate of the percentage of products actually launched compared to the number of concepts previously studied?

[ ] %

2) Can you give an estimate of the percentage of products that actually succeed on the market compared to the number of products launched?

[ ] %

3) Are there, within your company/group, regular and formalised procedures for measuring customer satisfaction?

Yes

No

4) What is, in your opinion, the impact of the following factors on the commercial success of your products?

	Not important at all					Extremely important	
	1	2	3	4	5		
- Previous market research	<input type="checkbox"/>	<input type="checkbox"/>	<input type="checkbox"/>	<input type="checkbox"/>	<input type="checkbox"/>	<input type="checkbox"/>	<input type="checkbox"/>
- Definition of customers' needs	<input type="checkbox"/>	<input type="checkbox"/>	<input type="checkbox"/>	<input type="checkbox"/>	<input type="checkbox"/>	<input type="checkbox"/>	<input type="checkbox"/>
- The R&D stage	<input type="checkbox"/>	<input type="checkbox"/>	<input type="checkbox"/>	<input type="checkbox"/>	<input type="checkbox"/>	<input type="checkbox"/>	<input type="checkbox"/>
- The production stage	<input type="checkbox"/>	<input type="checkbox"/>	<input type="checkbox"/>	<input type="checkbox"/>	<input type="checkbox"/>	<input type="checkbox"/>	<input type="checkbox"/>
- Administrative support	<input type="checkbox"/>	<input type="checkbox"/>	<input type="checkbox"/>	<input type="checkbox"/>	<input type="checkbox"/>	<input type="checkbox"/>	<input type="checkbox"/>
- Upstream collaboration with customers	<input type="checkbox"/>	<input type="checkbox"/>	<input type="checkbox"/>	<input type="checkbox"/>	<input type="checkbox"/>	<input type="checkbox"/>	<input type="checkbox"/>
- Collaboration with suppliers	<input type="checkbox"/>	<input type="checkbox"/>	<input type="checkbox"/>	<input type="checkbox"/>	<input type="checkbox"/>	<input type="checkbox"/>	<input type="checkbox"/>
- Collaboration with sub-contractors	<input type="checkbox"/>	<input type="checkbox"/>	<input type="checkbox"/>	<input type="checkbox"/>	<input type="checkbox"/>	<input type="checkbox"/>	<input type="checkbox"/>
- Upstream collaboration between the different departments of the company	<input type="checkbox"/>	<input type="checkbox"/>	<input type="checkbox"/>	<input type="checkbox"/>	<input type="checkbox"/>	<input type="checkbox"/>	<input type="checkbox"/>
- The technical characteristics of the product	<input type="checkbox"/>	<input type="checkbox"/>	<input type="checkbox"/>	<input type="checkbox"/>	<input type="checkbox"/>	<input type="checkbox"/>	<input type="checkbox"/>
- The product positioning compared to that of competitors	<input type="checkbox"/>	<input type="checkbox"/>	<input type="checkbox"/>	<input type="checkbox"/>	<input type="checkbox"/>	<input type="checkbox"/>	<input type="checkbox"/>
- Product design	<input type="checkbox"/>	<input type="checkbox"/>	<input type="checkbox"/>	<input type="checkbox"/>	<input type="checkbox"/>	<input type="checkbox"/>	<input type="checkbox"/>
- Product pricing	<input type="checkbox"/>	<input type="checkbox"/>	<input type="checkbox"/>	<input type="checkbox"/>	<input type="checkbox"/>	<input type="checkbox"/>	<input type="checkbox"/>
- The marketing support	<input type="checkbox"/>	<input type="checkbox"/>	<input type="checkbox"/>	<input type="checkbox"/>	<input type="checkbox"/>	<input type="checkbox"/>	<input type="checkbox"/>
- The advertising/external communication support	<input type="checkbox"/>	<input type="checkbox"/>	<input type="checkbox"/>	<input type="checkbox"/>	<input type="checkbox"/>	<input type="checkbox"/>	<input type="checkbox"/>
- The sales force	<input type="checkbox"/>	<input type="checkbox"/>	<input type="checkbox"/>	<input type="checkbox"/>	<input type="checkbox"/>	<input type="checkbox"/>	<input type="checkbox"/>
- The distribution network	<input type="checkbox"/>	<input type="checkbox"/>	<input type="checkbox"/>	<input type="checkbox"/>	<input type="checkbox"/>	<input type="checkbox"/>	<input type="checkbox"/>
- Delivery delays	<input type="checkbox"/>	<input type="checkbox"/>	<input type="checkbox"/>	<input type="checkbox"/>	<input type="checkbox"/>	<input type="checkbox"/>	<input type="checkbox"/>
- Services provided with the product	<input type="checkbox"/>	<input type="checkbox"/>	<input type="checkbox"/>	<input type="checkbox"/>	<input type="checkbox"/>	<input type="checkbox"/>	<input type="checkbox"/>
- Other(s) (please specify): .....	<input type="checkbox"/>	<input type="checkbox"/>	<input type="checkbox"/>	<input type="checkbox"/>	<input type="checkbox"/>	<input type="checkbox"/>	<input type="checkbox"/>
- .....	<input type="checkbox"/>	<input type="checkbox"/>	<input type="checkbox"/>	<input type="checkbox"/>	<input type="checkbox"/>	<input type="checkbox"/>	<input type="checkbox"/>
- .....	<input type="checkbox"/>	<input type="checkbox"/>	<input type="checkbox"/>	<input type="checkbox"/>	<input type="checkbox"/>		





If you so wish, we will be happy to send you a copy of our final report containing the results at a national level. To this end, please fill in the following details:

Mr., Ms.:	.....
Company :	.....
Address :	.....
	.....
	.....

## **APPENDIX THREE – FAX AND QUESTIONNAIRE 2**

**Fax and questionnaire (translated from the French version) used for the second quantitative stage**



FAX

**From: Laurence Rioche**

*Groupe Ecole Supérieure de Commerce de Rennes - Filière Nouvelles Technologies*

**Fax: 02.99.33.08.24**

Tél. (direct) : 02.99.54.63.32

e-mail : laurence.rioche@esc-rennes.fr

**To the attention of the Managing Director, or R&D Manager, or  
Marketing Manager or Production Manager**

**DATE:**

**Number of pages including this one: 4**

Dear Sir or Madam,

Please find enclosed a questionnaire concerning a doctoral study relating to new product development in the high tech companies operating in France. An initial exploratory survey was launched last year, the results of which will be presented in the coming weeks to an international conference in South Korea. However, deeper knowledge still needs to be gained about some precise points.

I would be very grateful if you could fill in the enclosed questionnaire by answering the questions in the most spontaneous way. Please use average marks on the grading scales only if they really reflect your opinion. If necessary, you can pass this questionnaire to the appropriate person in your company.

Please return this document by fax to:

**The attention of Laurence Rioche - 02.99.33.08.24  
By June 15<sup>th</sup>, 2000.**

Thank you in advance for your precious help.

Yours faithfully,

**Laurence Rioche**

***Research Assistant and Co-ordinator of the New Technologies Option***

\* In conformity with article 27 of regulation n° 78-17 of January 6th, 1978 concerning data processing and computer files, filling in this questionnaire is optional. Information that will be collected will only be used for statistical purposes and will be limited to an analysis by the survey's author. Data collected is accessible according to the conditions set by article 27 of the above mentioned regulation.



**GENERAL CHARACTERISTICS OF THE COMPANY**

1- How many people are employed in your company? *(If your company belongs to a group, please just give the number of people employed by the company).* ----- employees.

2- Does your company belong to a group? Yes  No

3- What is the APE code of your company? [ ] [ ] [ ] [ ]

4- Is the company certified by a quality organisation? *(One answer)*  
 Yes  Which one(s)? ----- In progress  No

5- In your company, is there a department:

- R&D	Yes <input type="checkbox"/>	No <input type="checkbox"/>
- Production	Yes <input type="checkbox"/>	No <input type="checkbox"/>
- Marketing	Yes <input type="checkbox"/>	No <input type="checkbox"/>

6- If the company belongs to a group, is there, in the group, a department:

- R&D	Yes <input type="checkbox"/>	No <input type="checkbox"/>
- Production	Yes <input type="checkbox"/>	No <input type="checkbox"/>
- Marketing	Yes <input type="checkbox"/>	No <input type="checkbox"/>

**PROJECT MANAGEMENT**

7- What is globally the respective percentage of customised and standardised products that is developed in your company? *(The total must be equal to 100%)*

Customised:	----- %
Standardised:	----- %
	----- 100%

8- During the development of a new product, are there different departments that collaborate within a same multi-disciplinary team? *(One answer)*

Yes, always       Yes, occasionally       No, never

↳ If 'yes, always' or 'occasionally', what are the departments that collaborate? *(One answer).*

R&D/marketing and production equally collaborate

R&D/production       Production/marketing       R&D/marketing

↳ Are these cross-functional exchanges mostly informal (conversations, e-mails, etc.) or formal (meetings, written documents, etc.)? *(Please circle the appropriate figure)*

Extremely informal		Medium		Extremely formal
1	2	3	4	5

9- In your company, do you consider that the frontiers between R&D, marketing and production are:

(Please circle the appropriate figure)

Extremely thin		Medium		Extremely thick
1	2	3	4	5

10- Globally, do you consider that R&D, marketing and production are equally involved in decision-making during new product development? (One answer)

Not at all  Medium  Yes, totally

11- Globally, is the new product development process not formalised (no precise procedures) or very formalised (precise procedures and milestones)? (Please circle the appropriate figure)

Not formalised		Medium		Extremely formalised
1	2	3	4	5

12- Is control from top management during new product development mostly informal or formal? (please circle appropriate figure)

Extremely informal		Medium		Extremely formal
1	2	3	4	5

13- Globally, what is the percentage of products that you launch in the market and which experience commercial success? (One answer)

<10%  10-25%  25-50%  50-75%  75-90%  >90%

<b>INFORMATION SYSTEM AND MARKETING</b>
-----------------------------------------

14- On a grading scale going from 0 to 10, how would you evaluate the following two aspects in your company? (please circle the appropriate mark)

14.1- Environmental scanning (i.e. competition, market evolution, etc.)?

Null		Medium		Excellent						
0	1	2	3	4	5	6	7	8	9	10

14.2- Feedback from customers?

Null		Medium		Excellent						
0	1	2	3	4	5	6	7	8	9	10

15- Is market follow-up mostly informal (no specific procedures) or formal (systematic feedback from the sales force and after sales service)? (please circle the appropriate figure)

Extremely informal		Medium		Extremely formal
1	2	3	4	5

16- On a grading scale going from 0 to 10, how would you evaluate the importance of the marketing culture in your company? *(please circle the appropriate mark)*

Null			Medium				Extremely strong			
0	1	2	3	4	5	6	7	8	9	10

17- On a grading scale going from 0 to 10, how would you evaluate the level of commercial and advertising effort in your company? *(please circle the appropriate mark)*

Null			Medium				Extremely strong			
0	1	2	3	4	5	6	7	8	9	10

<b>DESIGN</b>
---------------

18- Is there a design function in your company? Yes  No

↳ If 'no', and if your company belongs to a group, is there a design function in the group?

Yes  No

↳ If there is a design function in the company or in the group, is it subordinated to another department (for example, marketing, R&D or production) or is it an independent department? *(One answer)*

Design is subordinated to another department  Which one? .....

The design function is independent  Do not know

19- Do you collaborate with external designers? *(One answer)*

Yes, always  Yes, sometimes  Yes, but rarely  Never  Do not know

20- On a grading scale going from 0 to 10, how would you evaluate: *(please circle the appropriate mark)*

20.1- the importance granted to design in your company?

Null			Medium				Extremely strong			
0	1	2	3	4	5	6	7	8	9	10

20.2- the role of design to favour collaborations between R&D, marketing and production?

Null			Fairly efficient				Extremely efficient			
0	1	2	3	4	5	6	7	8	9	10

20.3- the role of design in a high tech company, in general?

Not important at all			Fairly important				Extremely important			
0	1	2	3	4	5	6	7	8	9	10

Please specify your position in the company: .....

**THANK YOU FOR YOUR PRECIOUS HELP**

Please return this questionnaire by fax: 02.99.33.08.24 to the attention of de Laurence RIOCHE

**BEFORE SEPTEMBER 15, 2000.**



**APPENDIX FOUR – COMPANIES CONTACTED FOR THE QUALITATIVE STAGE AND SEMI-STRUCTURED QUESTIONNAIRE**

Profiles of the five companies contacted for the qualitative stage and semi-structured questionnaire  
(translated from the French version)

## COMPANIES INTERVIEWED IN THE QUALITATIVE STAGE

### **Laboratoire Européen d'ADSL (LEA)**

Development and commercialisation of ADSL products.

40 employees.

Marketing department.

R&D department.

Production is sub-contracted.

No design department. Collaboration with a design consultant initiated in 1999.

### **E-generis**

Development of communication systems for small businesses.

55 employees.

Marketing department.

R&D department.

Production is sub-contracted.

No design department. Collaboration with design consultants.

### **Philips semi-conductors Rennes**

Design of integrated circuits for digital TV

70 employees

Marketing department

R&D department

Production is sub-contracted

Design department (design engineering).

### **Hercules Technologies SA**

Computing equipment and video games

500 employees

Marketing department

R&D department

Production is sub-contracted

Design department and collaboration with design consultants.

### **Acterna (formely Wandel & Goltermann)**

Telecommunication test equipment

4,000 employees

Marketing department

R&D department

Production department

No design department. Collaboration with design consultants.

## INITIATING A DESIGN-ORIENTED STRATEGY IN HIGH TECH COMPANIES

The meaning of the model:

- **1/** The characteristics of a company such as: size, management style, quality certification, technological intensity, existence of a marketing department were identified in previous research as influencing the implementation of a design-oriented strategy.
- **2/ DESIGN ORIENTATION IS INITIATED BY TOP MANAGEMENT**, in parallel with a strong customer orientation. To do so, top management must first carefully think about its corporate identity. Top management is then responsible for communicating about the benefits of design to the other employees. It must also provide adequate resources, favour the integration of the design function in the company and provide a design friendly atmosphere (minimum interference, informal exchanges, etc.).
- **3/ THE DESIGN FUNCTION IS DIRECTLY INVOLVED IN THE UPSTREAM STAGES OF NPD.** Together with the marketing department, it will involve the customers in the concept-testing stage, thanks to 3D techniques, prototypes, etc. Customers' expectations will be better defined.
- **4/ THE DESIGN FUNCTION IS DIRECTLY INVOLVED IN NPD.** It will favour inter-functional exchanges (especially with marketing, R&D and production) thanks to better visualisation and understanding of customers' requirements. This will decrease the impact of individual priorities among R&D, marketing and production. The design function will lead to more informal exchanges. It will favour the spreading of the design culture within the company and it will feed the information system together with the marketing department.
- **5/ PRODUCT DESIGN WILL VALUE CUSTOMERS' BENEFITS AND PRODUCT'S ADVANTAGES.** Design will enhance the technology incorporated in the product, the quality, etc. The final product will be user-friendlier.
- **6/ DESIGN WILL VALUE CORPORATE IDENTITY** in its competitive environment. The firm will have to send a 'message' corresponding to its internal values (which must have previously been defined by top management).
- **7/ EVENTUALLY, DESIGN WILL LEAD TO BETTER UNDERSTANDING OF CUSTOMERS' REQUIREMENTS** (since customers are integrated in the concept and testing stages) **AND IT WILL ENABLE THE COMPANY TO PROVIDE ADAPTED SOLUTIONS.** This will eventually lead to a better offer, higher loyalty, increased market share and higher profits.



**PAGE  
NUMBERS  
CUT OFF  
IN  
ORIGINAL**

**QUESTIONS:**

Name and position of the respondent : .....

Name of the company : .....

**The company:**

Activity? .....

APE code? [ ][ ][ ][ ]

Number of people employed: .....

Marketing department?            yes             no

R&D?                                    yes             no

Production?                        yes             no  / sub-contracted? .....

.....

Design department?            yes             no

Collaboration with external design consultant?    yes             no

**Your perception of the role of design?**

.....

.....

.....

.....

.....

.....

.....

.....

.....

.....

.....

.....

.....

.....

.....

.....

.....

.....

.....

.....

.....

.....

.....

**The model / Comments on the different parts**

**1- Factors influencing the organisation**

.....

.....

.....

.....

.....

.....

.....

.....

.....

.....

.....

.....

.....

.....

.....

.....

.....

.....

.....

.....

.....

.....

.....







.....  
.....  
.....  
.....  
.....

**7- Design favours a better identification of customers' requirements and provides adapted solutions**

.....  
.....  
.....  
.....  
.....  
.....  
.....  
.....  
.....  
.....  
.....  
.....  
.....  
.....  
.....  
.....  
.....  
.....  
.....  
.....  
.....

**Comments**

.....  
.....  
.....  
.....  
.....  
.....  
.....  
.....  
.....  
.....  
.....  
.....  
.....  
.....  
.....  
.....  
.....  
.....  
.....  
.....  
.....

For any further information: Laurence Rioche / ESC Rennes  
Tel.: 02.99.54.63.63 / 02.99.54.63.32  
Fax: 02.99.33.08.24 laurence.rioche@esc-rennes.fr