

Case Reports

Diagnosis of Spinocerebellar Ataxia in the West Indies

Ashley K. Yearwood¹, Shruthi Rethi¹, Karla P. Figueroa², Ruth H. Walker^{3,4} & Andrew K. Sobering^{1*}

¹Department of Biochemistry, St. George's University, St. George's, Grenada, West Indies, ²University of Utah, Department of Neurology, Salt Lake City, UT, USA, ³Department of Neurology, James J. Peters Veterans Affairs Medical Center, Bronx, NY, USA, ⁴Department of Neurology, Mount Sinai School of Medicine, New York City, NY, USA

Abstract

Background: Access to medical care in many regions is limited by socioeconomic status, at both the individual and the community level. This report describes the diagnostic process of a family residing on an underserved Caribbean island where routine neurological care is typically addressed by general practitioners, and genetic diagnosis is not available through regular medical channels. The diagnosis and management of neurodegenerative disorders is especially challenging in this setting.

Case Report: We diagnosed a family with spinocerebellar ataxia type 3 (SCA3) in an underdeveloped nation with limited access to genetic medicine and no full-time neurologist.

Discussion: Molecular diagnosis of the SCAs can be challenging, even in developed countries. In the Caribbean, genetic testing is generally only available at a small number of academic centers. Diagnosis in this family was ultimately made by utilizing an international, pro bono, research-based collaborative process. Although access to appropriate resources, such as speech, physical, and occupational therapies, is limited on this island because of economic and geographical factors, the provision of a diagnosis appeared to be ultimately beneficial for this family. Identification of affected families highlights the need for access to genetic diagnosis in all communities, and can help direct resources where needed.

Keywords: Spinocerebellar ataxia, socioeconomic status

Citation: Yearwood AK, Rethi S, Figueroa KP, Walker RH, Sobering AK. Diagnosis of spinocerebellar ataxia in the West Indies. Tremor Other Hyperkinet Mov. 2018; 8. doi: 10.7916/D8DV329C

*To whom correspondence should be addressed. E-mail: asobering@sgu.edu

Editor: Elan D. Louis, Yale University, USA

Received: April 15, 2018 **Accepted:** June 7, 2018 **Published:** June 26, 2018

Copyright: © 2018 Yearwood et al. This is an open-access article distributed under the terms of the Creative Commons Attribution–Noncommercial–No Derivatives License, which permits the user to copy, distribute, and transmit the work provided that the original authors and source are credited; that no commercial use is made of the work; and that the work is not altered or transformed.

Funding: St. George's University Small Research Grant Initiative 16021.

Financial Disclosures: None.

Conflicts of Interest: The authors report no conflict of interest.

Ethics Statement: This study was performed in accordance with the ethical standards detailed in the Declaration of Helsinki. The authors' institutional ethics committee has approved this study and all patients have provided written informed consent.

Introduction

In developed countries, it is a matter of course that individuals presenting with ataxia, chorea, dystonia, or tremor have access to a neurologist, often one specializing in movement disorders. Genetic diagnostic resources, if required, are generally available to these patients. In many other parts of the world, however, this standard of care may not be available or accessible because of a variety of factors, including geographical isolation or socioeconomic limitations.

There are hundreds of different forms of hereditary ataxia¹ and more than 40 different subtypes of spinocerebellar ataxia (SCA),

each caused by mutation of a different genetic locus.² The clinical features of the various SCA types are heterogeneous and may vary considerably, even within the same family. For this reason, genetic diagnosis of the specific SCA is important for establishing prognosis, genetic counseling, and potentially treatment.

SCA type 3 (SCA3) is caused by pathogenic expansion of an unstable CAG trinucleotide repeat in the *ATXN3* gene.³ The ages of onset of several different SCAs appear to be modulated by CAG tract lengths in various genes, in both the wild-type and expanded alleles.⁴ The most consistent clinical manifestation of SCA3 is ataxia, which almost never

occurs in isolation. Other features of SCA3 reflect progressive cerebellar and brainstem degeneration, and include dysfunction of oculomotor systems, pyramidal and extrapyramidal pathways, motor neurons, and peripheral nerves.⁵

Over the last 3 years, we have offered an annual pro bono neurology clinic with a board-certified movement disorders specialist (R.H.W.) on an island in the West Indies. We request referrals from local physicians for patients with Parkinson disease, tremor, ataxia, chorea, dystonia, or any gait disorder not caused by stroke. Coincident with our clinic, we also provide continuing medical education seminars accredited by the Caribbean Council of Family Physicians (Jamaica) to help increase the general understanding of movement disorders in the community.

Owing to the increased attention from clinicians on this island as a result of our clinic and seminars, we learned of an extended family comprising multiple individuals with progressive ataxia. We have previously described how access to neurological and genetic services is limited in this region.⁶

Neurological evaluations were performed (by R.H.W.) at the patients' home because of their limited mobility and access to transportation. Written informed consent was obtained from each patient for genetic testing and release of clinical and family history. Owing to the small population size of the countries (less than 100,000 residents) in which these patients reside, our institutional review board has requested that we do not reveal their precise nationalities or geographic locations. Consent was not given for publication of video documentation of the movement disorder. Genetic analysis was performed pro bono at an academic research laboratory in the USA.

Case report

Individual IV-4. The proband in this family (Figure 1) reported that she first began noticing gait problems at the age of 19 years. Over the next 6 years, her symptoms progressed, and she sought medical attention with complaints of dizziness, unsteady gait, and memory and hearing loss. Brain magnetic resonance imaging (MRI) was obtained and was reported to be normal. Her symptoms progressively worsened, and 9 years following symptom onset, the patient obtained a second brain MRI, which showed cerebellar atrophy (Figure 2A). By 13 years after symptom onset, the patient was unable to walk without support, swallowing was markedly impaired, and she had lost more than 30 pounds over the previous 6 years. She reported worsening memory problems and frequent falling. Fourteen years after symptom onset, a third brain MRI (Figure 2B) revealed increased prominence of the cerebellar folia, flattening of the pons and medulla, and atrophy of the spinal cord.

Neurological evaluation was performed at 15 years after symptom onset. The patient had a full range of eye movements, with frequent small amplitude saccadic intrusions, and nystagmus and overshoot on smooth pursuit and saccadic gaze. Optokinetic nystagmus (OKN) was normal. She had intermittent lower facial dystonia with a risus sardonicus, dystonic posturing of the fingers when the hands were outstretched, and dystonic flexion of the toes with repetitive movements. Speech was moderately dysarthric. There was moderate impairment of coordination of both upper and lower extremities, with mild hypo- and bradykinesia of hand movements. There was moderate truncal ataxia while sitting. Power was intact throughout, despite atrophy of hand muscles. The proband exhibited hyper-reflexia of all

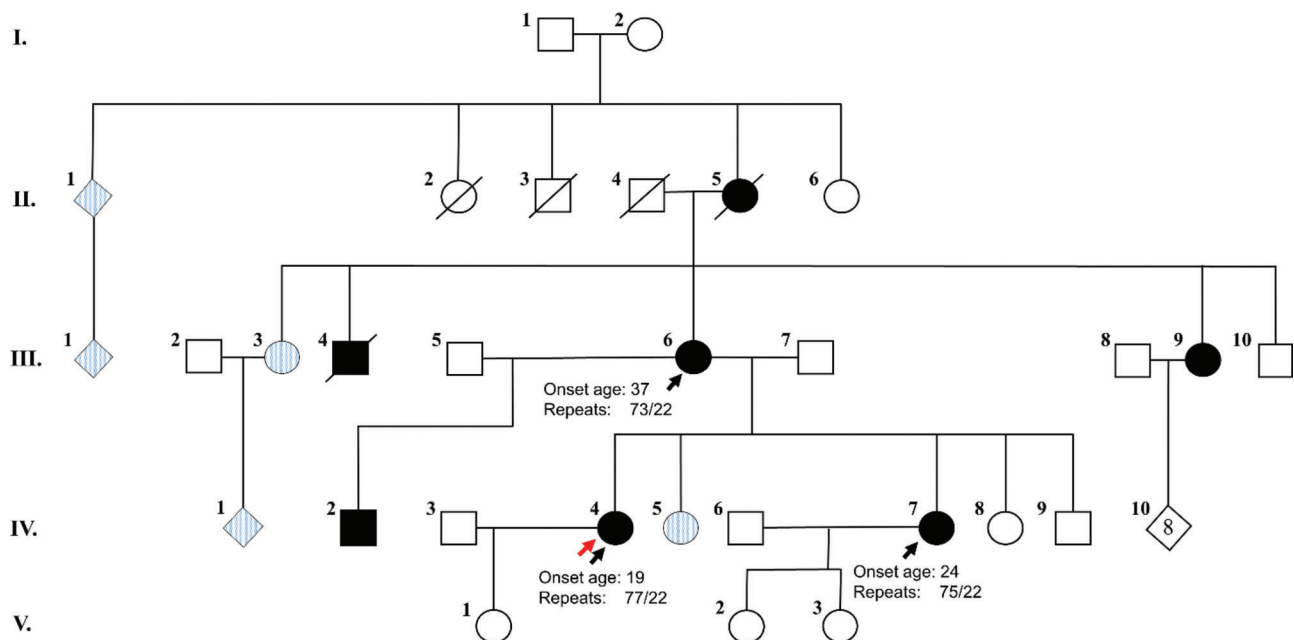

Figure 1. Autosomal Dominant Inheritance of SCA3 in a Caribbean Family. Solid symbols indicate affected subjects where family history was certain. The red arrow indicates the proband, and the black arrows indicate the three patients who were clinically examined. Intermediate symbols indicate individuals who are possibly affected based on family history. Age of onset and the number of CAG repeats in the *ATXN1* gene are indicated.

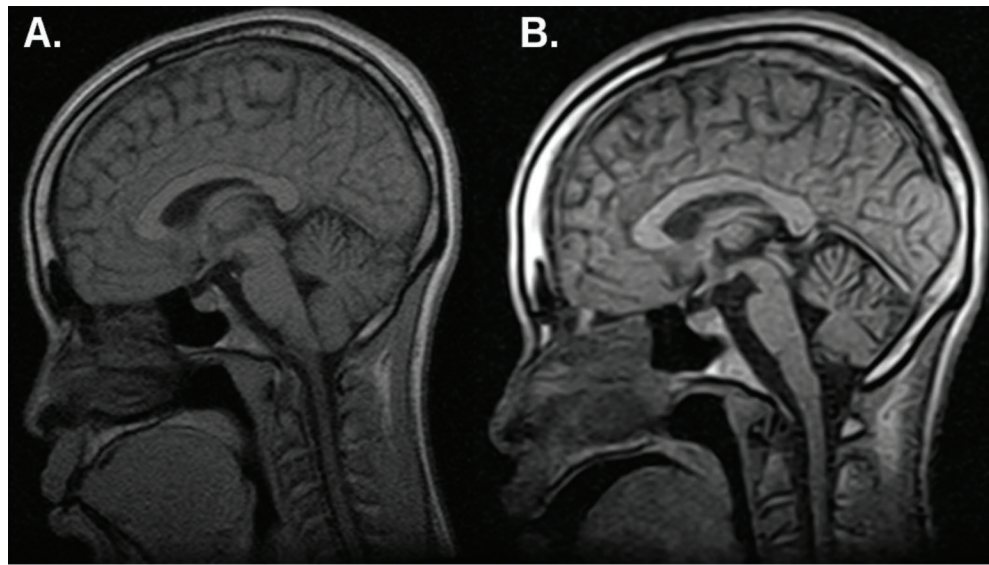

Figure 2. Brain Magnetic Resonance Imaging of Patient IV-4 Shows Progressive Cerebellar Degeneration and Atrophy of the Medulla, Pons, and Brainstem. (A) Nine years after symptom onset. (B) Fourteen years after symptom onset.

four limbs, with no Babinski sign. The vibration sensation was moderately impaired in all four limbs; however, sensory modalities were intact. She could only stand and walk with support. Gait was markedly wide-based, with dystonic plantar flexion of the feet on stepping. During this visit, the patient scored 21 on the Scale for Assessment and Rating of Ataxia (SARA; maximum = 40). Genetic testing showed a pathogenic expansion of 77 CAG repeats on one allele of the *ATXN3* gene and 22 repeats on the other.

Individual III-6. The 53-year-old mother of the proband reported that she developed gait difficulties at approximately 37 years of age. She is now unable to walk without support and she notes that her head shakes when she is tired or hungry. On examination, speech was moderately dysarthric and occasionally difficult to understand. In primary gaze, she had marked macrosaccadic jerks. The full range of eye movements was present; however, smooth pursuit and saccadic gaze both showed significant saccadic intrusions, and impairment of OKN was observed. Power was intact throughout, apart from mild weakness of wrist flexion and extension, and of finger abduction. Deep tendon reflexes were pathologically brisk in both arms and knees, and absent at the ankles. There was no Babinski sign. Coordination was mildly impaired in both arms and moderately impaired in both legs. Vibration sense was moderately impaired at both ankles, but intact in the upper limbs. Proprioception, pinprick, and light touch were normal. She could stand and walk with a little support, but was very unsteady, and gait was markedly wide-based. Her SARA score was 18. Genetic testing showed CAG repeats of 73 and 22 in *ATXN3*.

Individual IV-7. The 29-year-old sister of the proband first noticed gait problems at the age of 24 years. She continued to work without problems, but noted mild impairment of speech, swallowing, and balance. She had lost several pounds since disease onset, and reported

occasional, variable double vision. On examination, her speech was very mildly dysarthric. There were moderate macrosaccadic intrusions in the mid-position. There was nystagmus on smooth pursuit and saccadic gaze, with overshoot. Power was intact throughout. Deep tendon reflexes were brisk with distal spread. Ankle jerks were also brisk with two or three beats of clonus bilaterally. The Babinski sign was present on the left. There was mild impairment of vibration in all four limbs, but other modalities were intact. She had very mild impairment of coordination of all limbs, which was more marked on the left. Gait was mildly wide-based, with unsteadiness on turning and tandem gait. She swayed in the Romberg position. Her SARA score was 6.5, and genetic testing showed 75 and 22 CAG repeats in *ATXN3*.

Other family members. During our interviews with members of this family, we were told that other affected members exist; however, we were unable to establish contact with these individuals. Despite apparent geographic proximity, communication between inhabitants of neighboring villages is sometimes minimal because of various factors, including transportation and technological infrastructure limitations. This is further compounded for individuals affected by neurodegenerative disorders. It was also reported that affected individuals had moved to other countries such as Trinidad, Barbados, the USA, or the UK, and that contact had been lost. Currently, it is unknown if any of these other family members have been diagnosed with an ataxic disorder.

Discussion

Access to resources for genetic diagnosis varies greatly both within and between countries. In some countries, diagnostic genetic testing, at least for relatively well-recognized disorders, is readily accessible, while in others it is effectively impossible to perform.

(Documentation of access to genetic testing resources is a current project of the Rare Diseases Study Group of the International Parkinson Disease and Movement Disorders Society, via an electronic survey of Society members.)

The community in which this family resides is underserved and neurological specialty services are not available. Typically, people with neurological conditions are seen by family practice physicians, or referred to an internist if in hospital. Genetic diagnosis is generally unavailable for a variety of reasons, including lack of local services and low socioeconomic status. To date, all molecular diagnostic investigations performed have been carried out by the senior author (A.K.S.) in collaboration with local clinicians and medical students as extra-curricular academic activities.^{6,7} The informal process leading to the diagnosis was initiated when the proband sought medical attention from her primary care physician, who was aware of the research interests of the senior author.

Most genetic testing in this region occurs in academic centers in Cuba or Puerto Rico; however, even in these countries, it is more limited than in developed nations. Although West Indian nations are currently attempting to build capacity for genetic testing,⁸ overall, this type of service is lacking.^{9,10} To our knowledge, ours is only the second report of SCA3 in this region, the first being by Gwinn-Hardy et al.,¹¹ who described genetic diagnosis of SCA3 in a family residing in the UK and USA following immigration from Antigua. Apart from a cluster of families with SCA2 documented in the Holguin province of Cuba^{12–14} and a cluster of families on Martinique,^{15,16} there have not been any other reports of any of the SCAs in the Caribbean region.

The correct identification of the disorder allowed patients in this family to understand the implications for themselves and their offspring, and put a label to their symptoms. Advice about physical exercise and nutrition was offered as the best way to delay symptom progression;¹⁴ however, access to formal physical, speech, and nutritional therapy resources is limited by both geographical and economic factors. Owing to geographical isolation, it would be difficult to recruit these patients into any research study of SCA3, and even remote care using electronic communication is compromised by the limited technological resources on the island.

The patients we characterized in this study demonstrate the phenomena of anticipation¹⁷ wherein age of onset and disorder severity correlate with expansion of the triplet repeat. Table 1 compares the onset age to the triplet repeat expansion and each measured item on the SARA scale. As shown in Table 1, patients who have a larger number in repeats in *ATXN3* have an earlier age of onset and more severe symptoms than patients with fewer repeats in the gene.

This case report highlights a cultural block to the attainment of diagnosis. Although it was well known within the family that members across several generations were affected by a disease, only one family member, who was well-educated, sought medical attention. She received the non-specific diagnosis of ataxia; involvement of a movement disorders specialist and collaboration with an international research laboratory allowed us to definitively diagnose the condition

Table 1. Breakdown of Onset Age, *ATXN3* Triplet Repeats, and Individual Elements of the SARA Score

Patient	III-6	IV-4	IV-7
<i>ATXN</i> CAG repeats	73/22	77/22	75/22
Onset age	37	19	24
Current age	54	35	30
Years since onset	17	16	6
Gait	5	6	2
Stance	5	6	2
Sitting	0	1	0
Speech disturbance	3	2	1
Finger chase	1	2	1
Nose–finger test	0	0	0
Fast alternating hand movements	2	1	0.5
Heel–shin slide	2	3	0
Total SARA	18	21	6.5

Abbreviations: SARA, Scale for Assessment and Rating of Ataxia.

and facilitate genetic counseling. The identification of the genetic cause for the familial disorder appeared, in general, to be reassuring to the affected family members and allowed us to confidently educate the patients about autosomal dominant inheritance. However, it was apparent that the lack of effective treatments was a source of frustration for subject IV-7, who started researching “stem cell therapies”.

As a result of this case, and several others that we are currently investigating, we have garnered the interest of several local physicians and are currently making the case for the creation of a national registry for patients who have neurological degeneration or movement disorders. Owing to geographical isolation, it would be difficult to recruit these patients into a clinical trial for SCA3; technological limitations make eHealth impractical. Ancillary services such as physical therapy, speech therapy, and nutrition therapy exist to a limited degree; however, these families reside at large distances from where the services are offered, and do not have the means to travel. The purpose of this paper is to highlight these needs. We continue to support these patients with pro bono movement disorder consultations. Without our outreach program, these patients would not have access to this level of specialty medical services.

Acknowledgments

We thank the patients and their family members who participated in this study. We also thank the Urban Humanitarian Projects and the

Iota Epsilon Alpha medical honor society of St. George's University for donations to pay for imaging services.

References

1. Wallace SE, Bird TD. Molecular genetic testing for hereditary ataxia. *Neurol Clin Pract* 2018;8:27–32. doi: 10.1212/CPJ.0000000000000421
2. Sun YM, Lu C, Wu ZY. Spinocerebellar ataxia: relationship between phenotype and genotype – a review. *Clin Genet* 2016;90:305–314. doi: 10.1111/cge.12808
3. du Montcel ST, Durr A, Rakowicz M, Nanetti L, Charles P, Sulek A, et al. Prediction of the age at onset in spinocerebellar ataxia type 1, 2, 3 and 6. *J Med Genet* 2014;51:479–486. doi: 10.1136/jmedgenet-2013-102200
4. Du Montcel ST, Durr A, Bauer P, Figueroa KP, Ichikawa Y, Brussino A, et al. Modulation of the age at onset in spinocerebellar ataxia by CAG tracts in various genes. *Brain* 2014;137:2444–2455. doi: 10.1093/brain/awu174
5. Paulson H. Machado-Joseph disease/spinocerebellar ataxia type 3. *Handb Clin Neurol* 2012;103:437–449. doi: 10.1016/B978-0-444-51892-7.00027-9
6. Charles J, Lessey L, Rooney J, Prokop I, Yearwood K, Da Breo H, et al. Presentation and care of a family with Huntington disease in a resource-limited community. *J Clin Mov Disord* 2017;4:4. doi: 10.1186/s40734-017-0050-6
7. Sobering AK, Stevens JB, Smith JL, Nelson B, Donald T, Elsea SH. Genetic diagnosis of Down syndrome in an underserved community. *Am J Med Genet Part A*. 2017;176:1–4.
8. Pan American Health Organization. Report on strengthening research capacities for health in the Caribbean, 2007-2017. Washington DC. PAHO; 2017. Available at <http://iris.paho.org/xmlui/handle/123456789/34342>.
9. Estrada-Veras JI, Cabrera-Peña GA, Pérez-Estrella de Ferrán C. Medical genetics and genomic medicine in the Dominican Republic: challenges and opportunities. *Mol Genet Genomic Med* 2016;4:243–256. doi: 10.1002/mgg3.224
10. Roach A, Warner WA, Llanos AAM. Building capacity for human genetics and genomics research in Trinidad and Tobago. *Rev Panam Salud Publica* 2015;38:425–430.
11. Gwinn-Hardy K, Singleton A, O'Suilleabhain P, Boss M, Nicholl D, Adam A, et al. Spinocerebellar ataxia type 3 phenotypically resembling Parkinson disease in a black family. *Arch Neurol* 2001;58:296–299. doi: 10.1001/archneur.58.2.296
12. Velázquez Pérez L, Cruz GS, Santos Falcón N, Enrique Almaguer Mederos L, Escalona Batallan K, Rodríguez Labrada R, et al. Molecular epidemiology of spinocerebellar ataxias in Cuba: insights into SCA2 founder effect in Holguin. *Neurosci Lett* 2009;454:157–160. doi: 10.1016/j.neulet.2009.03.015
13. Velázquez-Pérez L, Rodríguez-Labrada R, García-Rodríguez JC, Almaguer-Mederos LE, Cruz-Mariño T, Laffita-Mesa JM. A comprehensive review of spinocerebellar ataxia type 2 in Cuba. *Cerebellum* 2011;10:184–198. doi: 10.1007/s12311-011-0265-2
14. Velázquez-Pérez LC, Rodríguez-Labrada R, Fernandez-Ruiz J. Spinocerebellar ataxia type 2: Clinicogenetic aspects, mechanistic insights, and management approaches. *Front Neurol* 2017;8:472–486. doi: 10.3389/fneur.2017.00472
15. Durr A, Smadja D, Cancel G, Lezin A, Stevanin G, Mikol J, et al. Autosomal dominant cerebellar ataxia type I in Martinique (French West Indies). Clinical and neuropathological analysis of 53 patients from three unrelated SCA2 families. *Brain* 1995;118:1573–1581. doi: 10.1093/brain/118.6.1573
16. Lezin A, Cancel G, Stevanin G, Smadja D, Vernant JC, Dürr A, et al. Autosomal dominant cerebellar ataxia type I in Martinique (French West Indies): Genetic analysis of three unrelated SCA2 families. *Hum Genet* 1996;97:671–676. doi: 10.1007/BF02281881
17. Shakkottai VG FB. Autosomal dominant spinocerebellar ataxia. *Neurol Clin* 2013;31:1–22. doi: 10.1016/j.ncl.2013.04.006