



ASIA TURBOMACHINERY & PUMP SYMPOSIUM
12 - 15 MARCH 2018
SUNTEC SINGAPORE

A NEW METHODOLOGY FOR VERIFYING PRESSURIZED START-UP OF CENTRIFUGAL COMPRESSORS DRIVEN BY DIRECT-ON-LINE ELECTRIC MOTOR BY LEVERAGING STRING TEST RESULTS AND DYNAMIC SIMULATION ANALYSIS

Mirco Calosi

Lead Engineer
Centrifugal Compressors & Turbo Expanders - System
Operability
Baker Hughes, a GE company
Florence, Italy

Ibrahim A. Kobbia

Rotating Machinery Eng. Section Leader
ADMA-OPCO
Abu Dhabi, United Arab Emirates

Luca Magnante

Electrical Manager
TechnipFMC
Rome, Italy

Marco Pelella

Engineering Manager
Centrifugal Compressors & Turbo Expanders - System
Operability
Baker Hughes, a GE company
Florence, Italy

Riccardo Ranieri

Lead Engineer
Centrifugal Compressors & Turbo Expanders - System
Operability
Baker Hughes, a GE company
Florence, Italy

Riccardo Lorenzini

Senior Engineer
Customer Project Engineering
Baker Hughes, a GE company
Florence, Italy



Mirco Calosi is Lead Engineer for System Operability of Centrifugal Compressor & Turbo Expander Applications at Baker Hughes, in Florence, Italy. His responsibility is to smoothly integrate Centrifugal Compressors and relevant drivers within the Oil & Gas plant to make sure all transient conditions are fully covered by the entire plant design. Mr. Calosi graduated with honor in Chemical Engineering at University of Pisa, Italy in 2008. He joined GE in 2014.



Ibrahim A. Kobbia is a Rotating Equipment Engineer, with 20 years of experience in Rotating Equipment Concepts, FEED, Engineering, Commissioning, Start-up and trouble shooting. Ibrahim is acting as head of Rotating Equipment technical Authority in ADMA-OPCO since 2010, he began his career in 1996 with Enppi, Cairo, as a rotating equipment engineer and in 2007 he joined CB&I Lummus, Netherlands as a principal Rotating Equipment Engineer/Manager Mechanical. Ibrahim received a B.SC. Degree, in Mechanical Power Engineering, from Cairo University in 1996.



Luca Magnante is a senior electrical manager with significant experience in corporate business management and on projects within the oil and gas industry. He has more than 16 years of experience with customers, contractors and suppliers in relation to the design, construction and commissioning of large EPC onshore projects, focused on HV/MV/LV complex generation and distribution systems, large electrical machines and latest electrical technology developments. Mr. Magnante graduated in Electrical Engineering at University of Rome “La Sapienza” in 2000, got the Professional Engineering Qualification Degree in 2001 and attended a master course on Power System Engineering Specialization at EDSA S.A, San Diego (California) in 2002.



Marco Pelella is Engineering Manager for NPI Systems Engineering & Operability of Centrifugal Compressor & Turbo Expander Applications at Baker Hughes, in Florence, Italy. His responsibilities include the new product system and architecture definition, the definition of process control philosophies, development of dynamic simulations and optimization for Centrifugal Compressors and Turbo Expanders applications. He joined GE in 1999 as Centrifugal Compressors Design Engineer and covered several positions as Centrifugal Compressor Design Manager working on integrally geared compressors, pipelines, LNG and Down Stream applications until the 2014 when he took the present role. Mr. Pelella graduated with honor in Mechanical Engineering at University of Naples, Italy in 1997, he has authored and coauthored 8 papers in compressor field and he presently holds 10+

patents.



Riccardo Ranieri is Lead Engineer for System Operability of Centrifugal Compressor & Turbo Expander Applications at Baker Hughes, in Florence, Italy. His responsibility is to ensure the correct operability of Centrifugal Compressor and Turbo Expander trains and comply with Plant requirements. Riccardo got PhD in Particle Physics at University of Florence and worked ten years at discovery of Higgs Boson particle within L3 and CMS international collaborations at CERN. He joined GE in 2012.



Riccardo Lorenzini is Senior Customer Project Engineering, his responsible of the development and execution of the projects for natural gas applications. He is responsible for technical execution of a project. Mr. Riccardo Lorenzini graduated in Aeronautical Engineer in 2001 in Pisa, following the degree he worked 2 years as flight test engineer in Alenia Aeronautica, in 2003 joined GE as gas turbine Design Engineer and in 2007 he moved in project engineering team.

ABSTRACT

Fixed Speed Electric Motors driving Centrifugal Compressors are designed considering the pressurized start-up as the most critical condition in terms of the torque requirement. Their capability is checked during the design phase by means of dynamic simulation, which unfortunately suffers from uncertainties, especially in the low speed range.

String Test (Complete Unit Test as defined by API 617) is a powerful mean to validate and refine the dynamic simulation so to predict more accurately the behavior of the compressor train at site conditions and ensure the capability of the driver to start-up the compressor from Settled-Out condition.

The present paper describes a new methodology to leverage Direct-On-Line Centrifugal Compressor String Test results to improve predictability of on-site pressurized start-up thanks to an enhanced dynamic simulation model.

A case study is also presented showing how the methodology has been successfully applied to a reinjection compressor string.

1. INTRODUCTION

In the Oil & Gas Industry, Centrifugal Compressor driven by Direct-On-Line (DOL) Fixed Speed Electric Motor (FSEM) is a widely-used train configuration that has advantages in terms of CAPEX, OPEX, maintenance, availability, reliability and reduced footprint. Criticalities of this configuration, from an Operability standpoint, are concentrated mainly in the start-up phase where, especially in case of pressurized start-up, due to the high torque absorbed by the compressor, the electric network of the plant is highly stressed and the capability of the Motor is the main constraint on the start-up feasibility.

API 617 and API 541 regulate acceptance criteria for start-ups of DOL Motor driven compressors. The motor developed torque, with

80% of rated voltage at the motor terminals, shall exceed the load torque by a minimum of 10% (motor rated torque as base) at all locations throughout the speed range up to the motor breakdown torque point. In addition, the time required to accelerate the train shall be below the safe hot stall (locked rotor) time by an amount specified in the API Standards.

These requirements are checked during the design phase by means of Electric Motor and Centrifugal Compressor train and gas loop dynamic simulation.

In an advanced stage of project execution, String Test (Complete Unit Test as defined by API 617 [1], in section 6.3.3.2 of Part 2, carried out testing together all the components that make up the complete unit) is also used to verify the start-up capability of the driver, but the test cannot replicate exactly the conditions that will be experienced at site due to different piping layout, plant volumes, equipment, electric network characteristic and initial pressure achievable at test bench.

However, String Test results are still an important information to validate and refine dynamic simulation so to predict more accurately the behavior of the compressor train at site conditions.

The paper is organized as follows: an overview on DOL FSEM criticalities and verification is given in Section 2; in Section 3, the new methodology to enhance dynamic simulation model leveraging String Test data is presented; Section 4 describes a case study where the new methodology has been applied to an industrial application; next steps to further improve the methodology are presented in Section 5; conclusions are given in Section 6.

2. DOL FSEM VERIFICATION

Generally, the DOL FSEM capability of starting-up the compressor train shall be checked from pressurized condition called settling out pressure (SOP) condition. In that condition the suction density can be even an order of magnitude higher than the normal suction condition one that causes the increase of the required torque to ramp up the train above the rated torque in normal conditions. The compressor absorbed torque during ramp up is a fraction of the compressor rated torque at the rated speed; that fraction can be estimated with the square ratio of the speeds (rated and actual) according to the affinity law. This is valid only if the compressor inlet conditions in terms of pressure, temperature and gas composition are kept constant all along the ramp up. Under this hypothesis, since the polytropic head and the volumetric flow are, in the first approximation, functions of speed only, the fluid torque scaling rule mentioned above applies.

Typically, the compressor inlet conditions during a pressurized start-up change continuously all along the ramp up, then similitude conditions are not fulfilled and affinity law does not apply. Only dynamic simulations can correctly predict the absorbed fluid torque from zero to rated speed taking into account the interaction among compressor, valves and all the other plant components. Thus, during the design phase, Electric Motor and Centrifugal Compressor train and gas loop dynamic simulation is developed to reproduce the behavior of the system at site condition with the aim of:

- Verifying Driver capability to start-up the train from Settled Out Pressure (SOP) as per API requirements;
- Calculate the maximum pressure at which the Driver is capable to start-up the train;
- Define the correct start-up sequence that minimizes the compressor absorbed torque so that depressurization of the gas loop is not required or minimized in case the Driver is not capable of starting-up the train from SOP.

The acceptance criterion for the driver start-up capability is based on the comparison between the driver torque capability and the driven machine absorbed torque. A sufficient margin shall be kept in order to ensure enough accelerating torque and guarantee the start-up feasibility. Equation (1) shall be verified during the entire start-up: from zero to rated speed.

$$T_{margin} = \frac{T_{EM} - T_{CC}}{T_{EM, rated}} = \frac{I \cdot \dot{\omega}}{T_{EM, rated}} > 10\% \quad \text{Eq. 1}$$

In Equation (1), the driver available torque is calculated at the actual speed, which changes during the start-up event.

The compressor absorbed torque includes the contribution of compressor fluid torque, mechanical losses and Break-Away Torque, as described by Equation (2).

$$T_{CC} = T_{fluid} + T_{losses} + T_{BAT} \quad \text{Eq. 2}$$

- Fluid torque is defined by Equation (3).

$$T_{fluid} = \frac{m_{inlet} \cdot H_{pol}}{\eta_{pol} \cdot \omega} \quad \text{Eq. 3}$$

- Mechanical loss torque includes the contribution of the bearings, Dry Gas Seal and gearbox (if any);
- Break away torque is the torque required at zero speed to overcome the static friction forces in the compressor bearings and gearbox wheels and bearings to start rotating the shaft line.

It is expected that other plant electrical items are running during the compressor train start-up and so the network voltage may be less than the rated one. Thus, it is conservative to use a reduced voltage for startup studies (80% as suggested by API) and the consequent reduced output torque.

Figure 1 shows an example of dynamic simulation outputs for a successful start-up. The plot shows that the critical range is around 70-90% of rated speed where the difference between the motor available torque and the load torque is at the minimum.

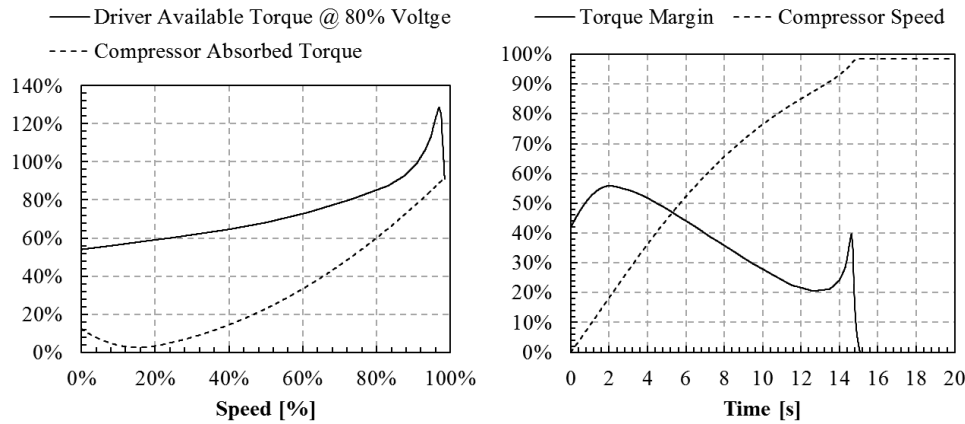

Figure 1. Typical start-up dynamic simulation outputs

For FSEM, it shall also be verified that the starting time is lower than the maximum allowable one specified by electric motor OEM. Usually, hot rotor locked time is taken as the start-up time limit (the rotor locked time is the maximum permitted starting time, in view of a dangerous temperature rise that could affect the service life of the motor itself).

If start-up acceptance criteria described above are not met, there are several possible solutions to decrease the starting torque and make the start-up feasible. Usually one of the following solutions are adopted: partial depressurization of the compressor loop, partial closure of suction throttling valve or partial closure of anti-surge valve.

Partial depressurization from SOP

Depressurizing the compression loop from SOP to a lower pressure, venting the gas to the flare, reduces startup fluid torque, since suction gas density and consequently inlet mass flow is reduced.

This is one of the simplest solution to make the start-up successful, since it does not require the installation of additional devices. However, venting the compression loop gas to the flare has economic and environmental impacts.

In order to avoid gas flaring, alternate solutions to depressurize the compression loop can be possible. In case no check valve is present at compressor suction, a small by-pass line around the suction isolation valve can be kept open: in this way, the process gas will migrate to the suction header and the pressure in the compression loop shall decrease down to a value close to suction header pressure. Another option consists in depressurizing the compression loop to a portion of the plant at lower pressure, compared to the SOP.

Suction throttling valve

The mass conservation applied to the compressor loop during a start-up in closed loop (neglecting the effect of the gas temperatures and compressibility factor variation) can be expressed using Equation (4).

$$P_S \cdot V_S + P_D \cdot V_D = SOP \cdot (V_S + V_D) \quad \text{Eq. 4}$$

Being VR the ratio between discharge and suction compressor loop volumes and PR the ratio between discharge and suction pressures, Equation (4) can be rearranged in Equation (5).

$$P_S = \frac{SOP \cdot (1 + VR)}{1 + PR \cdot VR} \quad \text{Eq. 5}$$

Installing a throttling valve upstream of the compressor suction, inside the recirculation loop (see Figure 2), and partially closing it during the start-up, allows to maximize both VR and PR , thus minimizing the suction pressure. This results in reducing the suction gas

density and then the compression fluid torque.

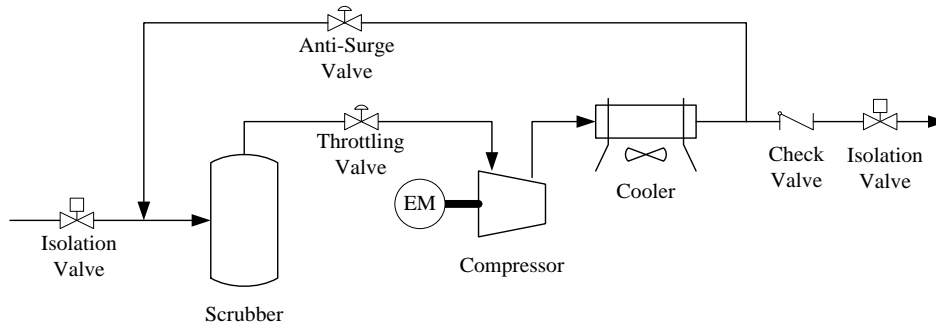

Figure 2. Installation of throttling valve to reduce torque requested for start-up

The throttling valve is a solution that requires the installation of an additional device if was not foreshadowed by the control philosophy of the compressor. It shall be fail open and shall be fitted with a mechanical stop to prevent, in any circumstance, the complete closure of the valve.

Anti-surge valve partial closure

Generally, moving the compressor operating point towards the Surge Control Line, the compressor absorbed power decreases (see Figure 3).

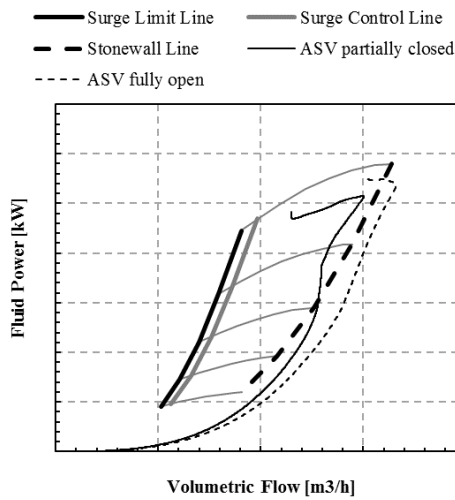

Figure 3. Torque reduction by partial closure of anti-surge valve

Based on this, partial closing of anti-surge valve during startup could help to reduce the fluid torque to a certain extent. This due to the fact partial closure of the anti-surge valve shall reduce the volume flow being circulated within the compression loop, resulting in less power consumption at startup and hence less torque. However, partial closing of the anti-surge valve is less effective than using a throttling valve because it does not minimize the volume ratio.

3. THE NEW METHODOLOGY

Start-up verification performed during the design phase through dynamic simulation analysis is subject to uncertainties, especially in the low speed range, where friction factors for Break-Away Torque (BAT) calculation are based on conservative assumptions and compressor thermodynamic behavior cannot be precisely defined due to lack of test data in this speed range. However, dynamic simulation model reliability can be enhanced by leveraging the String-Test results, thus improving predictability of on-site pressurized start-up.

The methodology to refine the dynamic simulation model developed during the design phase concept is described below. First, a String Test dynamic simulation model shall be developed, implementing test bench piping layout, volumes and equipment (coolers, valves, scrubbers, etc.). The model shall reflect String Test condition also in terms of initial start-up pressure and gas composition, which may differ from the one that will be present at site.

Since the main scope of the present procedure is to find any discrepancy between simulated and measured compressor absorbed torque, a data matching of the measured data is required. Thus, in order to replicate String Test results using the dynamic model, the simulation shall be run by imposing the speed ramp measured during the String Test. Doing so, the simulation results in terms of gas flow rate processed by the compressor and suction and discharge pressures can be compared to the measured data.

At this point, the simulation model shall be adjusted to match the test data. The adjustments that may be required are mainly due to any possible misalignment between test bench equipment behavior and design data that has been used to build the dynamic simulation model. The scope is to reproduce the pressure profiles along the compressor loop during the entire start-up by tuning the pressure drop and/or volume of each equipment. In this procedure, a critical role is played by the anti-surge valve which is the element that produces the highest pressure drop in the loop. At the end of the dynamic model tuning, the operating point path in the compressor performance envelope estimated by the simulation should match the one measured during the String Test start-up.

Compressor absorbed torque estimated by the dynamic model can now be compared with the torque measured in the test. Usually a torque meter is installed in the train shaft and can be used to retrieve the compressor absorbed torque, however it is advisable to calculate the torque from train acceleration using the torque balance equation (Equation (6)).

$$T_{CC} = T_{EM} - I \cdot \dot{\omega} \quad \text{Eq. 6}$$

where:

- I is a design data
- $\dot{\omega}$ is measured during the test
- T_{EM} is given by the Electric Motor speed-torque curve measured during the Electric Motor Factory Tests and scaled according to the voltage applied at the motor terminals during the compressor String Test

The discrepancy between simulated and measured absorbed torque is eventually used to refine the dynamic simulation model to better predict start-up behavior and driver capability at site conditions.

Electric Motor speed-torque characteristic

It is evident that, for the described procedure, the knowledge of the real speed-torque curve of the Electric Motor is critical. The speed-torque characteristic of the Electric Motor can be measured, per IEEE Standard 112, with any one of the following four methods:

- “Measured output”: A DC generator, that has its losses previously determined, is coupled or belted to the motor being tested and an AC power supply of rated frequency is connected to the motor terminals. The torque of the motor is calculated at different speeds measuring DC generator power output and knowing its losses (including friction and windage). The speed of the motor for each test point is controlled by varying the load on the generator.
- “Acceleration”: The motor is started with no load, and the value of acceleration is determined at various speeds. The torque at each speed is determined from the acceleration of the mass of the rotating parts, as per Equation (7).

$$T_{EM} = I \cdot \dot{\omega} \quad \text{Eq. 7}$$

Accurate measurements of speed and acceleration are an essential requirement of this method. The acceleration time should be long enough so that electrical transient effects in the instruments and in the motor do not distort the speed-torque curve, and also to permit recording the necessary number of mechanical and electrical measurements with sufficient accuracy for plotting the required curves.

- “Input”: The motor torque is determined by subtracting the losses in the machine from the input power. This method is a valuable check on the other methods, but in practice, it is approximate because the stator losses cannot be readily determined for the actual operating conditions and, therefore, must be approximated. This method is also subject to error in the case of special machines that may have substantial positive or negative harmonic torques that are not readily evaluated.
- “Direct measurement”: The motor torque and current are measured as the machine is loaded at various speeds with a dynamometer or mechanical brake.

Usually, acceleration method is used as it is simple to execute and gives accurate results. The test is carried out imposing a constant voltage (rated or reduced) to the motor terminals and the speed-torque characteristic is measured at that voltage.

As detailed in [4], the Electric Motor available torque during the start-up can be calculated solving the approximate per phase equivalent circuit of induction motors shown in Figure 4.

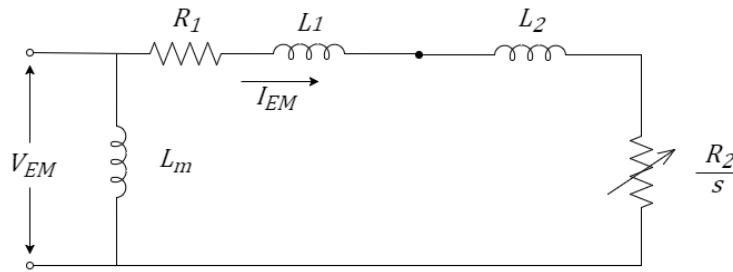

Figure 4. Approximate per phase equivalent circuit of induction motors

Electric Motor torque results in being a function of motor electric circuit resistances (R_1, R_2) and inductances (L_1, L_2), supply frequency ω_e , number of pole pairs p , the slip s (that can be correlated with actual rotor speed) and finally the square of supply voltage V_{EM}^2 as detailed in Equation (8).

$$T_{EM} = \frac{3 \cdot p \cdot V_{EM}^2}{s \cdot \omega_e} \frac{R_2}{\left(R_1 + \frac{R_2}{s}\right)^2 + \omega_e^2 \cdot (L_1 + L_2)^2} \quad \text{Eq. 8}$$

For a given Electric Motor and electric network (i.e. with constant values of resistances, inductances, supply frequency and number of pole pairs), the torque supplied by Electric Motor is a function only of the slip (i.e. rotor speed) and the square of supply voltage. Hence, speed-torque characteristic relevant to different voltages from the one at which torque measurements has been performed, can be estimated scaling the speed-torque curves measured with the square of supply voltage.

However, it should be recognized that, because of saturation of the leakage flux paths, the torque may increase by a ratio somewhat greater than the square of the voltage. The relationship varies with design; but scaling the torque with the square of voltage can be a good first approximation.

4. CASE STUDY

The methodology of improving dynamic simulation model leveraging on String-Test start-up results described in Section 3 has been successfully applied to the reinjection compressor string shown in Figure 5.

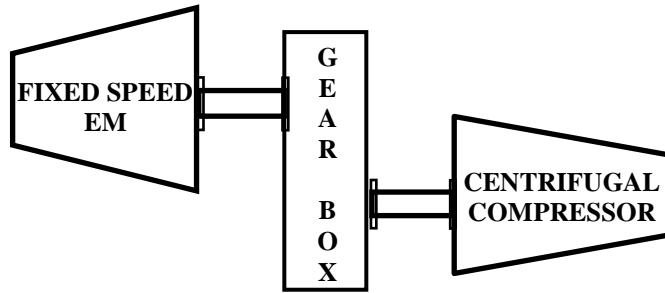

Figure 5. Case Study compressor string configuration

The train shaft line includes a 3.33MW 1500rpm Fixed Speed Electric Motor coupled to barrel type Centrifugal Compressor BCL305/C through a double helical Gear Box. Maximum allowable start-up times of the FSEM specified by Electric Motor OEM are reported in Table 1. The compressor has a nominal speed of 11700 rpm, a design suction pressure of 197.5 bar and a design discharge pressure of 371.0 bar. Inertia of each element in the shaft line is reported in Table 2.

Table 1. Maximum allowable EM starting times

Starting Voltage	Hot condition	Cold condition
80 %	29 s	37 s
85 %	23 s	30 s
90 %	20 s	27 s

Table 2. Shaft line Inertia referred to Low Speed Shaft

	Inertia @ LSS [kg×m ²]
Compressor	15.1
Coupling Compressor-Gear	4.8
Gear Box	214.1
Coupling Gear-Driver	6.2
Electric Motor	306.7
TOTAL	546.9

Start-Up Simulation

During design phase, start-up simulation from settled-out condition has been carried out to verify the driver capability. Outputs of the analysis are reported in Figure 6.

Results of dynamic simulations show that, even if the starting time is within the maximum limit imposed by the OEM, the electric motor is not able to start-up the train from SOP with ASV fully open respecting the Torque Margin limit of 10% imposed by API. The reason resides mainly in the high flow processed by the compressor due to the size and the complete opening of the ASV that moves the compressor operating path toward the choke region.

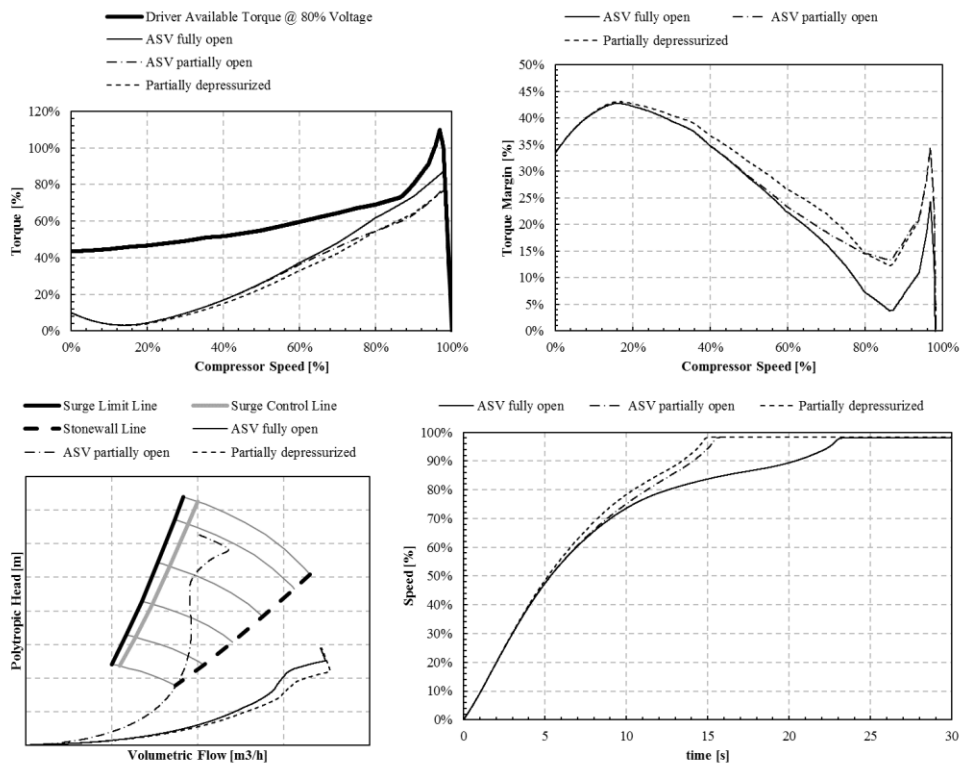

Figure 6. Design phase start-up simulation results

Two solutions have been studied and proposed to End User: partial closure of ASV during start-up or partial depressurization of the compressor loop. Partial closure of suction throttling valve was not considered as the valve is placed outside the anti-surge loop and so it does not affect the compressor operating condition in full recycle.

Both solutions allow to start-up the train successfully with similar margins as shown in Figure 6. The partial closure of ASV reduces both the flow processed by the compressor and the suction gas density thanks to the higher pressure ratio generated. The partial depressurization does not affect the operating path of the compressor, but decreases the overall level of gas density, resulting in a lower power absorbed by the compressor. A depressurization from 285 to 242 bar is required to reach the 10% torque margin.

Dynamic simulation is a proven and reliable tool for predicting the compressor train behavior during start-up, as it contains the know-how and experience of compressor and electric motor OEMs. However, some residual uncertainty is always present and String Test data can be used to validate or refine simulation results.

String Test Arrangement

Test bench configuration for the compressor String Test is reported in Figure 7.

The testing loop was equipped with two recycle solenoid valves with different size installed in parallel, so as to give flexibility and accuracy in controlling the compressor operating point position in the performance envelope. A gas cooler was installed at the suction of the compressor. Four dynamic pressure transducers and four thermocouples were installed on suction and discharge of the compressor. Flow rate measurement was performed by differential pressure transducers installed on suction.

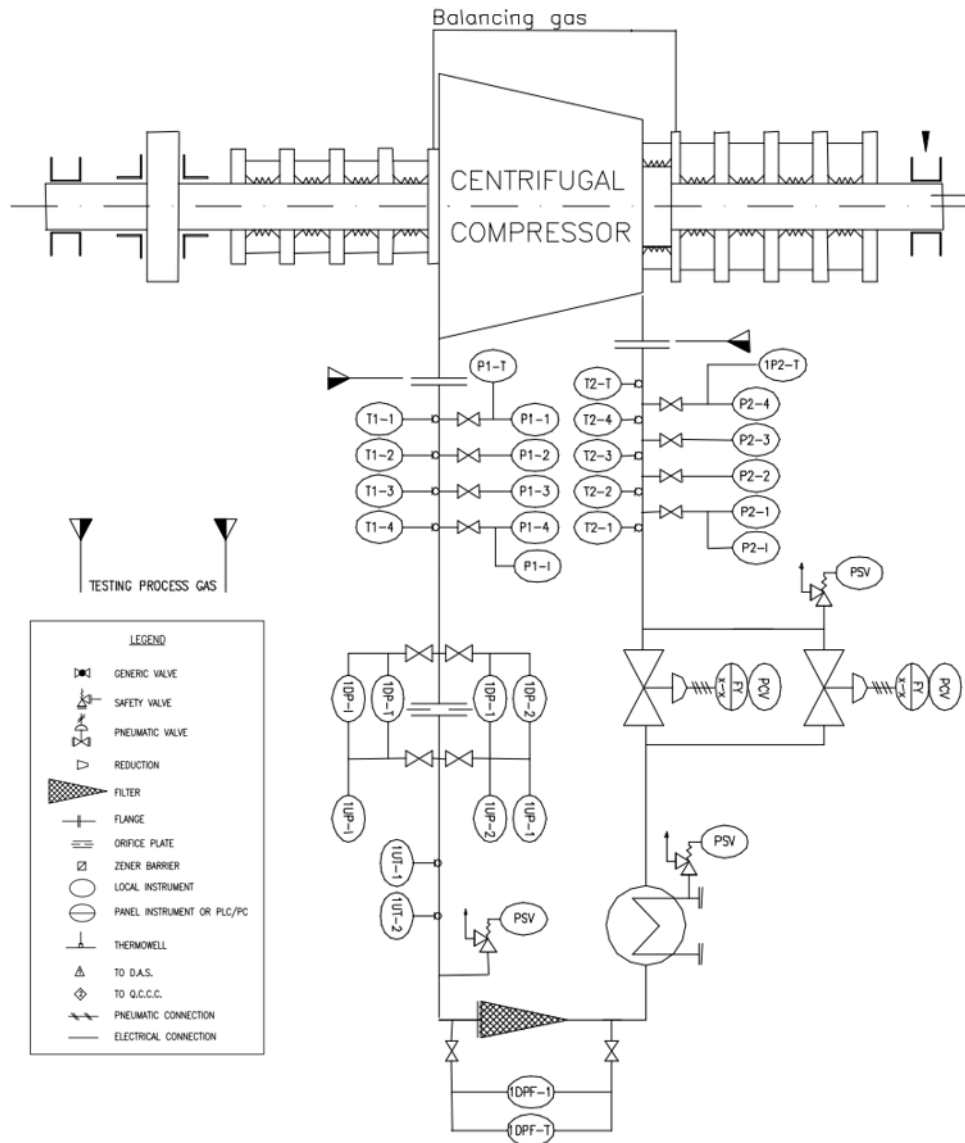

Figure 7. Test Bench configuration

During the String Test, the following activities and tests have been conducted:

- **Pre-test activities:**
 - Calibration of Project/Shop instruments
 - Instrumentation and electrical equipment insulation and continuity tests
 - Control loops check and functional test
 - Safety and protection devices operational checks
 - Mechanical equipment alignment check
 - Lube oil system flushing and cleanliness test
- **Compressor performance test ASME PTC10 type 1:** the test has the aim to demonstrate satisfactory performance of centrifugal compressor

- **Full speed full load string test and noise test:** the test has the aim to demonstrate the satisfactory mechanical behavior of the complete compressor package under full load condition and to demonstrate the functionality of the main auxiliary systems of the package
- **Electric Motor start-up in DOL verification:** the test has the aim to verify the Motor starting capability at site settle out pressure
- **Post-test inspections:**
 - Centrifugal compressor bearing inspection
 - Dry Gas Seals removal and internal inspection

Testing procedures are reported in Figure 8 and Figure 9.

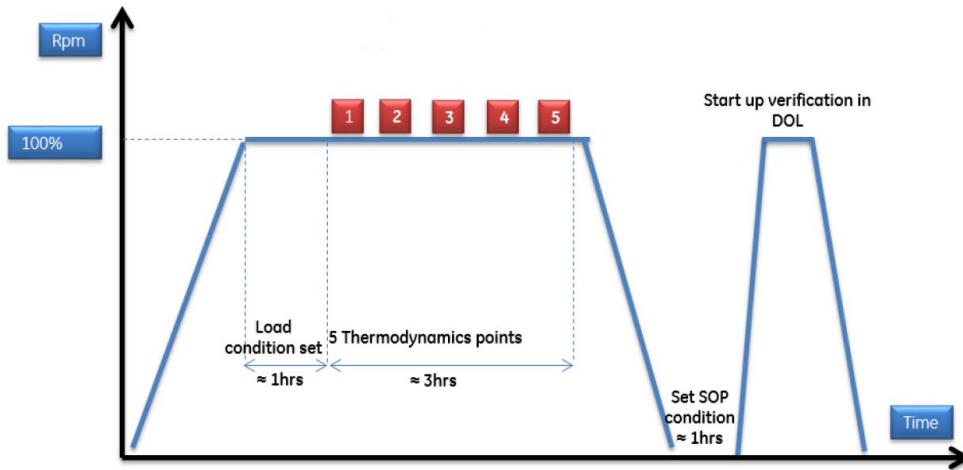

Figure 8. Performance test & Start-up in DOL verification sequences

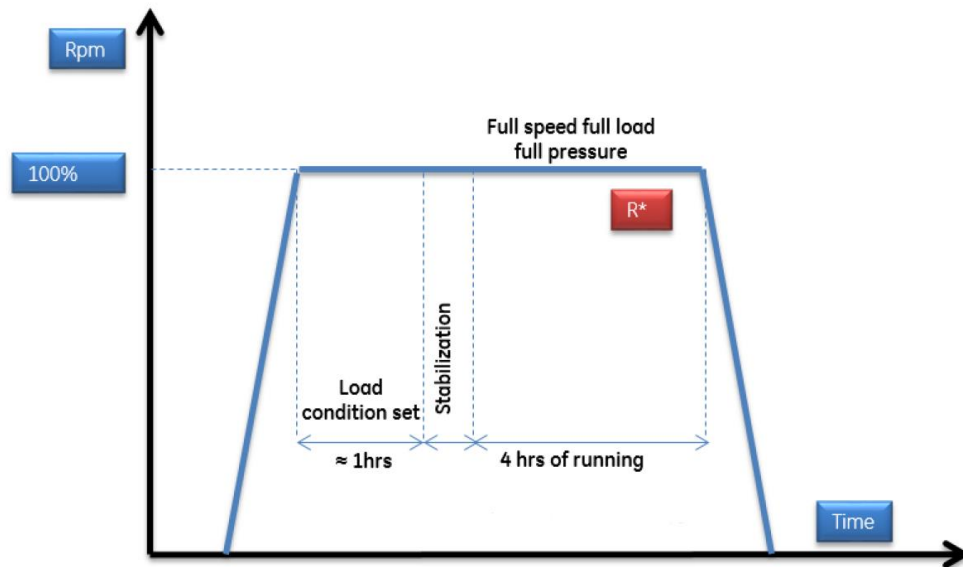

Figure 9. Full load test sequence

String Test start-up simulation

As first step, a dynamic simulation model of the test bench has been developed including all the main equipment of the compressor loop. The model has been built with the AspenTech HYSYS® v7.3 simulation software, configured with Peng-Robinson equation-of-state and the Lee-Kesler option for the calculation of enthalpies. Before the String Test execution, the dynamic simulation model of the test bench has been used to find the initial gas temperature and pressure of the loop and the ASV opening, to reproduce the loading curve and compressor operating path estimated for the site

condition. The partial depressurized start-up with ASV fully open, giving the 10% torque margin, has been taken as reference. The initial pressure and ASV opening calculated in this way is a good indication to perform a DOL start-up test that replicates with the highest accuracy the most critical start-up conditions that will be experienced at site.

Data Matching

After the string start-up tests, the simulation model has been adjusted to match the measured data. The adjustments were needed mainly because the initial pressure and temperature (and composition) used during the tests were different from the ones suggested in advance by the simulation. In fact, it is difficult to match pressure and temperature values during the test bench compressor loop pressurization, considering that also a certain gas composition has to be achieved when pressurizing the loop with different gas reservoirs.

Moreover, also the opening of the ASV at the indicated value is not enough to guarantee that the expected compressor operating path in the performance envelope can be reproduced. This is because of a possible misalignment between ASV and/or other equipment behavior and their datasheet.

Expected trend of pressures, flow, speed and compressor operating path compared to measured ones are reported in Figure 10 and Figure 11. Data match of the same variables after the adjustment done on the String Test simulation model are reported in Figure 12.

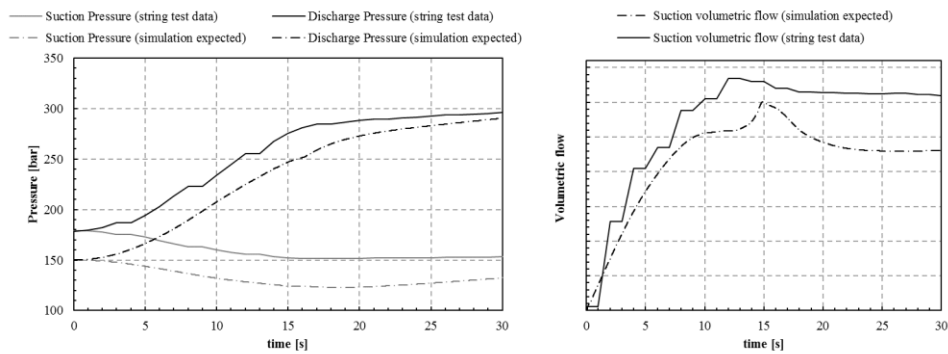

Figure 10. Expected trend of pressures and gas flow in String Test start-up Vs. measured one

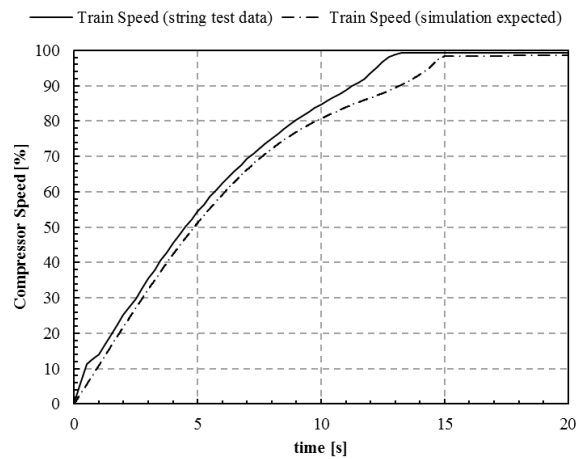

Figure 11. Expected trend of train speed in String Test start-up Vs. measured one

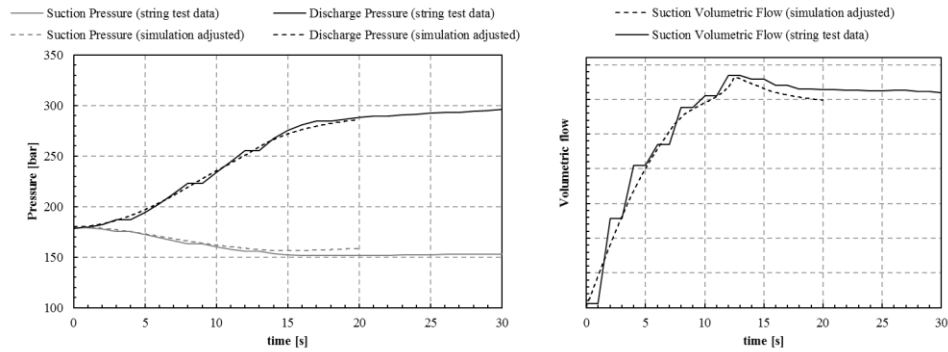

Figure 12. Simulated pressures and gas flow in String Test start-up Vs. measured one after model adjustment

Expected Vs. Measured Torque Comparison

Additional output of the adjusted simulation model is the compressor absorbed torque that can now be compared with the measured one. As discussed in Section 3, train absorbed torque is computed from the speed acceleration using Equation (6), given the overall inertia of the train and the Electric Motor speed-torque curve. The torque supplied by Electric Motor has been estimated scaling the speed-torque curves measured by OEM during Factory Tests with the square of supply voltage, in accordance with Equation (8). Voltage applied at Electric Motor terminals and measured during the String Tests is reported in Figure 13.

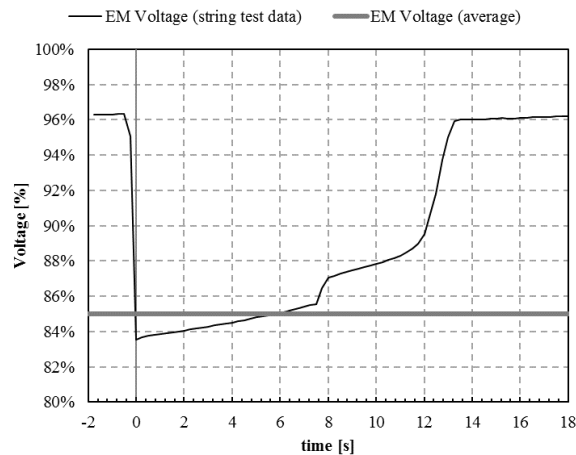

Figure 13. Voltage measured at the Electric Motor terminals during the String Test

An average value of the voltage measured at the Electric Motor terminals during the start-up test (85%) was used to scale the driver available torque curve measured during the Electric Motor Factory Tests. Resulting Electric Motor torque -speed curve used in Equation (6) is shown in Figure 14. Electric Motor OEM tested the machine according to the IEEE Standard 112 using the acceleration method and provided speed-torque curves at 100% and 80% of nominal voltage. Figure 15 shows the high degree of similitude of the two curves, which have been used to calculate the speed-torque characteristic of the Electric Motor at other voltages.

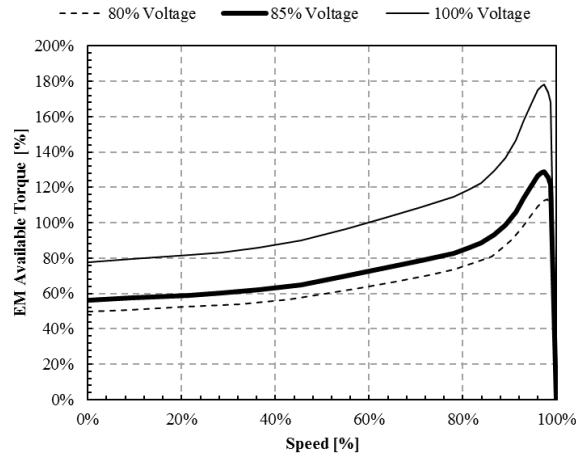

Figure 14. Electric Motor Factory Tests speed-torque curves

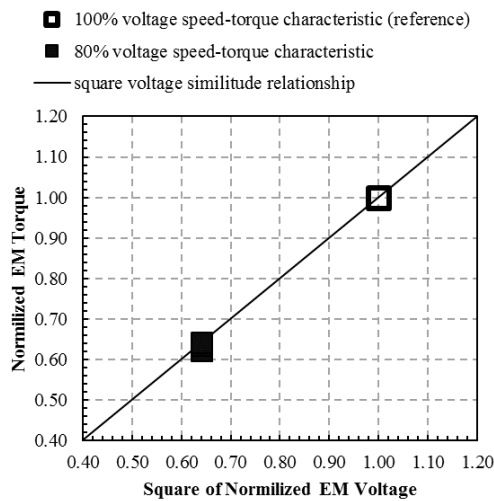

Figure 15. Electric Motor Factory Tests speed-torque curves similitude plot

The discrepancy between simulated and measured compressor string absorbed torque is reported in Figure 16. Only compressor fluid torque and mechanical friction losses from simulation has been considered, letting the discrepancy to incorporate also the BAT.

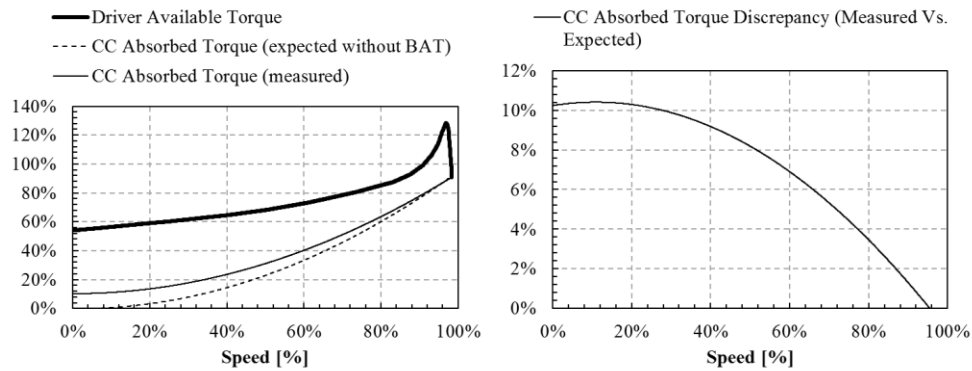

Figure 16: Discrepancy between simulated and measured compressor string absorbed torque

Figure 16 shows that the discrepancy between simulated and measured compressor string absorbed torque is concentrated mainly in

the low speed range. Being higher than the expected absorbed torque, at least a higher starting time is expected, with respect to the one calculated during the design phase of the project.

The reason of this discrepancy has to be mainly attributed to uncertainties with BAT, mechanical losses and thermodynamic behavior in the low speed range and deep choke operation due to lack of testing data on compressors, as well as electric motors.

In the 80-90% speed range, i.e. in the region where the train absorbed torque approaches the driver available one, the difference between simulated and measured torque drops and becomes almost negligible, suggesting that the torque margin calculated during the design phase will not change.

Enhanced Dynamic Model applied to site condition

The dynamic simulation model of the real plant has been modified including the results obtained from the String Test start-up data analysis. The discrepancy in the train absorbed torque (Figure 16) has been scaled according to the final absorbed power at full speed and added to the fluid and friction compressor torque.

Start-up scenario results of the enhanced dynamic model is shown in Figure 17 where the two solutions proposed to the End User for a successful start-up in accordance with API requirements (partial closure of ASV during start-up and partial depressurization of the compressor loop) are presented.

The main conclusions drawn in the design phase are confirmed.

As expected, the minimum torque margin has not been affected: it is still in the range of 10-15%. Only the starting time increased due to the higher absorbed train torque in the low speed range. However, the starting time increase (2-3 seconds) is small enough to remain far below the maximum limit indicated by the electric motor OEM.

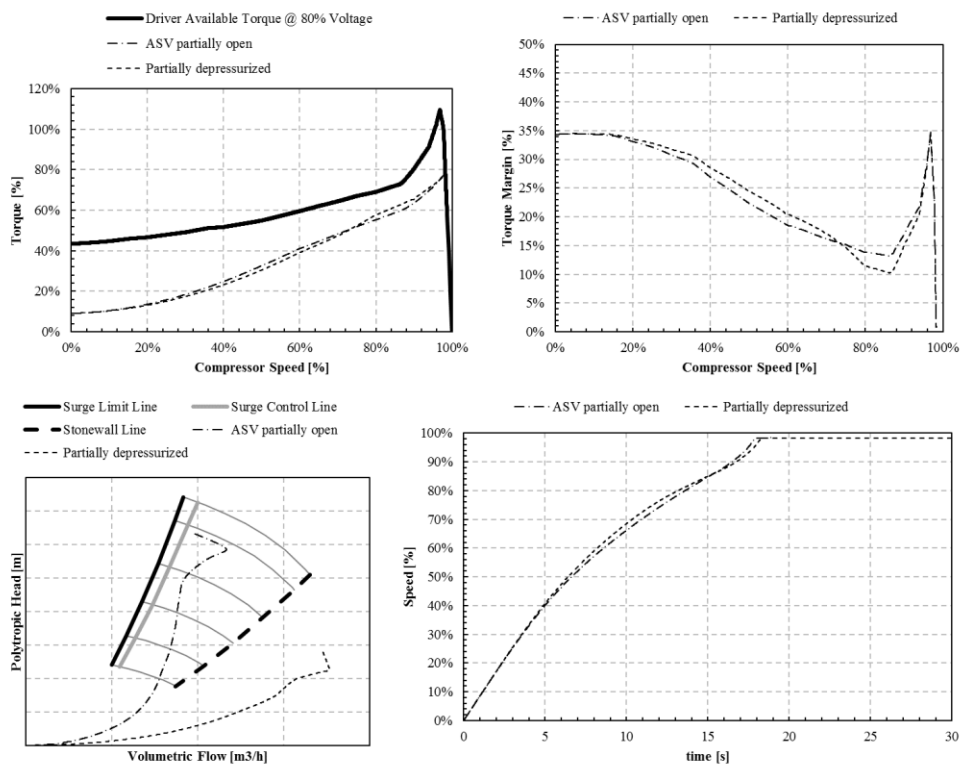

Figure 17. Enhanced dynamic simulation model start-up results

5. FUTURE DEVELOPMENT

During the start-up of the motor, at zero speed ($s = 1$) the start-up current is around 3-7 times the rated current, which leads the voltage supply to drop due to the impedances of the electrical network related to cables, transformers, etc.

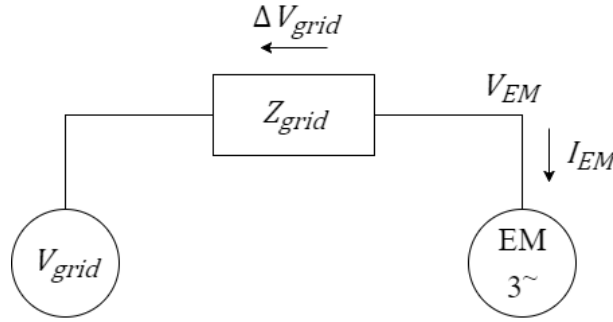

Figure 18. Electrical model scheme of Electric Model and electric network

$$V_{EM} = V_{grid} - \Delta V_{grid} = V_{grid} - Z_{grid} \cdot I_{EM} \quad \text{Eq. 9}$$

While motor accelerates ($s \rightarrow \text{Rated Slip}$), the current decreases with the rule described by Equation (10) and voltage applied at motor terminals increases back.

$$I_{EM} = \frac{V_{EM}}{\sqrt{\left(\left(R_1 + \frac{R_2}{s}\right)^2 + \omega_e^2(L_1 + L_2)^2\right)}} \quad \text{Eq. 10}$$

This analytical behavior is confirmed by test data as shown in Figure 13.

Therefore, considering a constant voltage applied to the Electric Motor terminals, then a fixed torque-speed curve (Figure 14), is an assumption that may not be valid: the motor voltage heavily affects the available driver torque, and during the DOL start-up, the voltage changes significantly.

To further refine the dynamic simulation for a better prediction of the DOL start-up, the next step is to drop this assumption and develop an electrical model of the motor and the electrical network of the plant to be used in place of a fixed torque-speed curve. Such a model could be used to improve both site and String Test dynamic simulations, connecting it to the compressor loop model as shown in Figure 19.

The integrated electrical and process simulation model will be able to also predict the voltage drop expected at site during the compressor start-up and to consider the effective electric motor available torque.

With the integrated model, the API requirement of considering only 80% voltage at electric motor terminals could be relaxed and it will be possible to assess if the compressor train can actually be started-up at site from the settled-out conditions, or what the real depressurization level is required to allow a safe start-up.

6. CONCLUSIONS

A new methodology to use Direct-On-Line Centrifugal Compressor String Test results in improving the predictability of on-site pressurized start-up has been presented.

The methodology has been successfully applied to a reinjection compressor string composed of a Fixed Speed Electric Motor, a Gear Box and a Centrifugal Compressor. The case study showed how the discrepancy between expected and measured train absorbed torque is concentrated principally in the low speed range, which is related to the uncertainties with BAT, mechanical losses and thermodynamic behavior in this speed range.

Nevertheless, in the 80-90% speed range, the difference between expected and measured torque is minimal and becomes almost negligible, meaning that the analysis performed during the design phase through dynamic simulations can be considered reliable in estimating the minimum torque margin and therefore relevant API requirement can be verified at the project design stage.

When maximum starting time of the DOL Electric Motor imposed by OEM is the main constraint of the driver capability in starting up the compressor train, then a good knowledge of the train absorbed torque along the entire speed range (from zero to rated speed) shall be vital. Accordingly, enhancing the dynamic simulation model by leveraging String Test data becomes essential.

The new methodology proposed can be improved by including in the simulation the electrical model of the motor and the electrical network of the plant. In this way, the compressor train dynamic simulation model will be further refined, thus allowing to minimize the design margins of train driver, and the associated cost, thanks to the improved predictability.

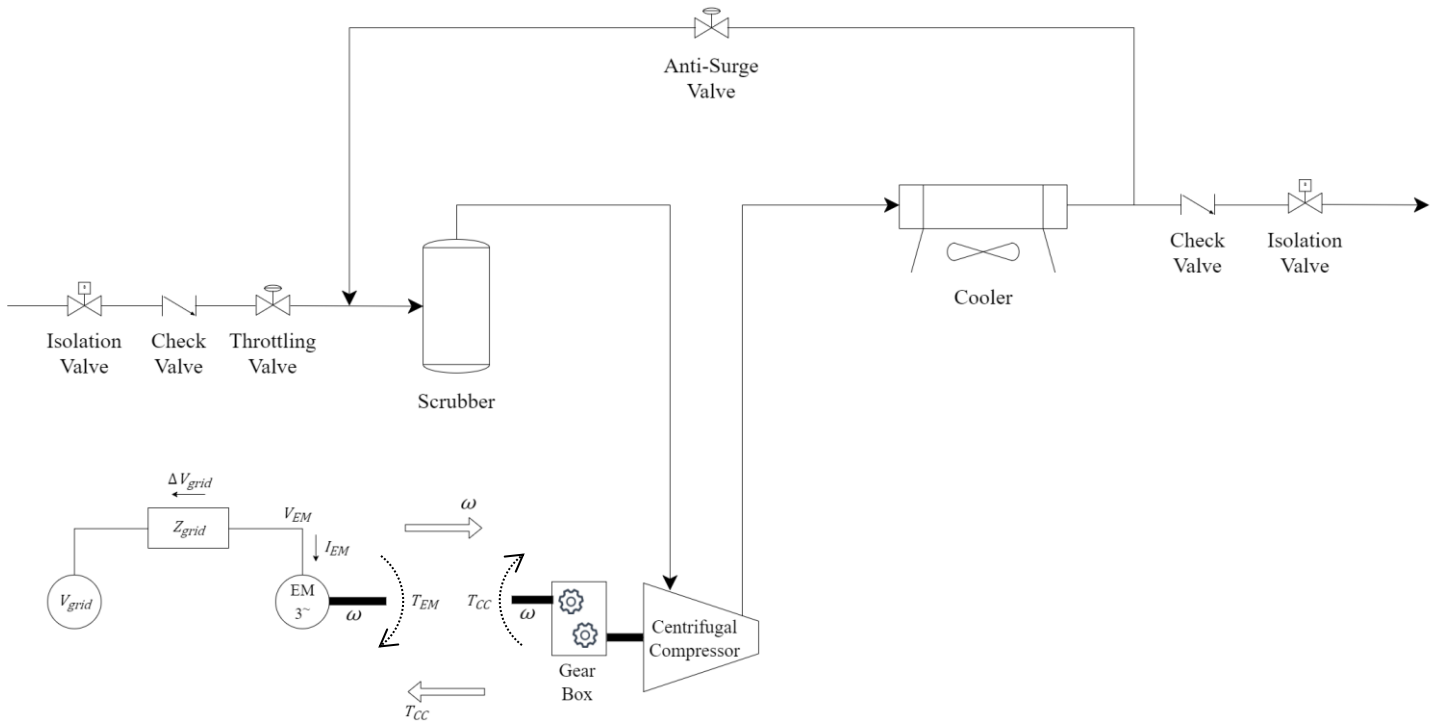

Figure 19. Electrical model scheme and integration with compressor loop dynamic simulation

NOMENCLATURE

Variables

I	= Overall train inertia	$(M \cdot L^2)$
$\dot{\omega}$	= Train angular acceleration	(t^{-2})
ω	= Train rotational speed	(t^{-1})
T_{EM}	= Electric Motor available torque	$(M \cdot L^2 \cdot t^{-2})$
T_{margin}	= Torque margin	$(M \cdot L^2 \cdot t^{-2})$
$T_{EM,rated}$	= Electric Motor rated torque	$(M \cdot L^2 \cdot t^{-2})$
T_{CC}	= Compressor absorbed torque	$(M \cdot L^2 \cdot t^{-2})$
T_{fluid}	= Compressor fluid torque	$(M \cdot L^2 \cdot t^{-2})$
T_{losses}	= Train mechanical friction torque	$(M \cdot L^2 \cdot t^{-2})$
T_{BAT}	= Break-Away torque	$(M \cdot L^2 \cdot t^{-2})$
m_{inlet}	= Compressor mass flow	$(M \cdot t^{-1})$
H_{pol}	= Compressor polytropic head	$(L^2 \cdot t^{-2})$
η_{pol}	= Compressor polytropic efficiency	$(-)$
P_S	= Suction Pressure	$(M \cdot L^{-1} \cdot t^{-2})$
V_S	= Suction Volume	(M^3)
P_D	= Discharge Pressure	$(M \cdot L^{-1} \cdot t^{-2})$
V_D	= Discharge Volume	(M^3)
SOP	= Settled Out Pressure	$(M \cdot L^{-1} \cdot t^{-2})$
PR	= Pressure Ratio	$(-)$
VR	= Volume Ratio	$(-)$
R_1, R_2	= EM equivalent circuit resistances	$(M L^2 I^{-2} t^{-3})$
L_1, L_2	= EM equivalent circuit inductances	$(M L^2 I^{-2} t^{-2})$
ω_e	= EM supply frequency	(t^{-1})
s	= EM slip	$(-)$
p	= EM number of pole pairs	$(-)$
V_{EM}	= EM supply voltage	$(M L^2 I^{-1} t^{-3})$
I_{EM}	= EM current	(I)
V_{grid}	= Electric network voltage	$(M L^2 I^{-1} t^{-3})$

Z_{grid}	= Electric network impedance	$(M L^2 I^{-2} t^{-3})$
ΔV_{grid}	= Electric network voltage drop	$(M L^2 I^{-1} t^{-3})$

Acronyms

API	= American Petroleum Institute
ASV	= Anti-Surge Valve
BAT	= Break Away Torque
CC	= Centrifugal Compressor
DOL	= Direct On Line
EM	= Electric Motor
FSEM	= Fixed Speed Electric Motor
HSS	= High Speed Shaft
LNG	= Liquefied Natural Gas
LSS	= Low Speed Shaft
OEM	= Original Equipment Manufacturer
SOP	= Settled Out Pressure

REFERENCES

- [1] API Standard 617, 8th edition, September 2014, “Axial and Centrifugal Compressors and Expander-compressors”
- [2] API Standard 514, 5th edition, December 2014, “Form-wound Squirrel Cage Induction Motors—375 kW (500Horsepower) and Larger”
- [3] IEEE Standard 112, 2004, “Test Procedure for Polyphase Induction Motors and Generators”
- [4] Bose B. K., 2001, “Modern Power Electronics and AC Drives”, Prentice Hall