



ASIA TURBOMACHINERY & PUMP SYMPOSIUM  
MARCH 2018 | SUNTEC SINGAPORE

# NPSHR (NPSH3) IMPROVEMENT OF A LOW PRESSURE SAFETY INJECTION PUMP

Frank Visser & Mark Ketelaar

# Biography – Frank Visser

Frank Visser is Principal Engineer at Flowserve, Aftermarket Services & Solutions, in Etten-Leur, The Netherlands. He obtained a B.S. degree (Mechanical Engineering, 1985) from Technical College Alkmaar, The Netherlands, and a M.S. degree (Mechanical Engineering, 1991) and Ph.D. degree (Technical Sciences, 1996) from the University of Twente, The Netherlands. He has received the ASME 2017 Sankaraiyer Gopalakrishnan-Flowserve Pump Technology Award, is a member of the Royal Netherlands Society of Engineers (KIVI), a member of the Industrial Advisory Board for the J.M.Burgerscentrum (JMBC), National Research School for Fluid Mechanics in the Netherlands, a member of ASME, and former Associate Editor for ASME Journal of Fluids Engineering (two terms).



# Biography – Mark Ketelaar

Mark Ketelaar is Senior Design Engineer at Flowserve, Aftermarket Services & Solutions, in Etten-Leur, The Netherlands. He obtained a B.S. degree (Mechanical Engineering, 2006) from Avans University of Applied Sciences, The Netherlands. He is involved in centrifugal pump design upgrades analyzed by computerized simulations. He worked in several Flowserve test laboratories and customer sites to verify theoretical study results with empirical data.



# Short Abstract

This case study discusses the rerate of a set of vertically-mounted single-stage end-suction centrifugal pumps used for low pressure safety injection (LPSI) in a nuclear power plant. The original LPSI pumps were supplied early 1970's and for safety purposes it was decided to overhaul these pumps to improve NPSHR (i.e. NPSH3).

The rerate consisted of replacing the existing impeller with a new design yielding close to identical head performance characteristic, yet better NPSHR. Aim was to improve NPSHR by (minimally) 0.5 m (1.64 ft) at rated capacity of 682 m<sup>3</sup>/h (3003 USGPM) and 1470 r/min running speed, and demonstrate by test the actual improvement in NPSHR



# Contents

- Particulars
- Design Objectives
- CFD Study
- Experimental Testing
- Results
- Concluding Remarks



# Particulars

- Re-assessment of Low Head Safety Injection (LHSI) pumps at a nuclear power plant (→ safety improvement)
- LSHI pumps are part of the Emergency Core Cooling System (ECCS), and they serve to:
  - Inject water from the refueling water storage tank into the reactor coolant system during large breaks
  - Provide makeup water for Residual Heat Removal (RHR)



# Particulars

- RHR System:



**LHSI (RHR)  
Pumps**

- 

RHR SYSTEM - INJECTION

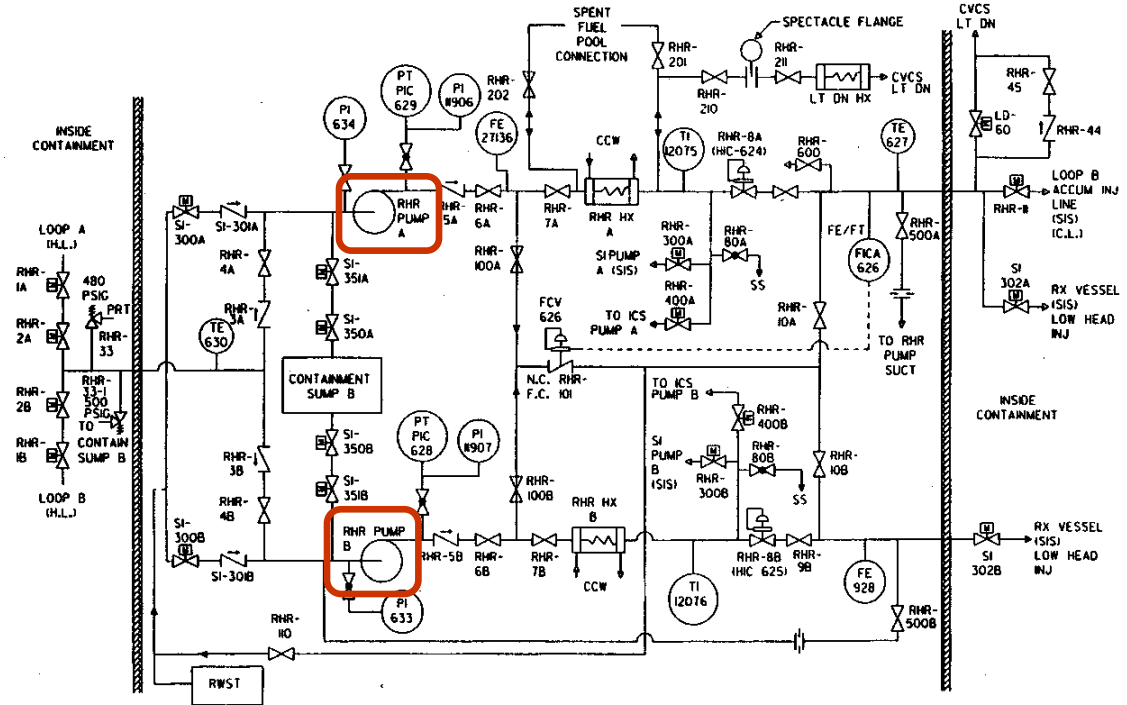

Refueling Water Storage Tank



# Particulars

- During long term core cooling, RHR recirculation mode debris (from the containment sump) could partially clog the sump filter lowering the NPSHA for the LSHI pumps
- This necessitated an impeller upgrade to improve NPSHR (NPSH3)





# Particulars

- **LHSI Pump**
  - Single stage
  - Single suction
  - Overhung design
  - Vertically installed
- **COS (existing)**
  - Speed = 1470 RPM
  - Capacity = 682 m<sup>3</sup>/h
  - Head = 69 m
  - NPSHR = 4.5 m
  - NPSHA = 4.6 m

$$F_{NPSH3} = 1.02!$$

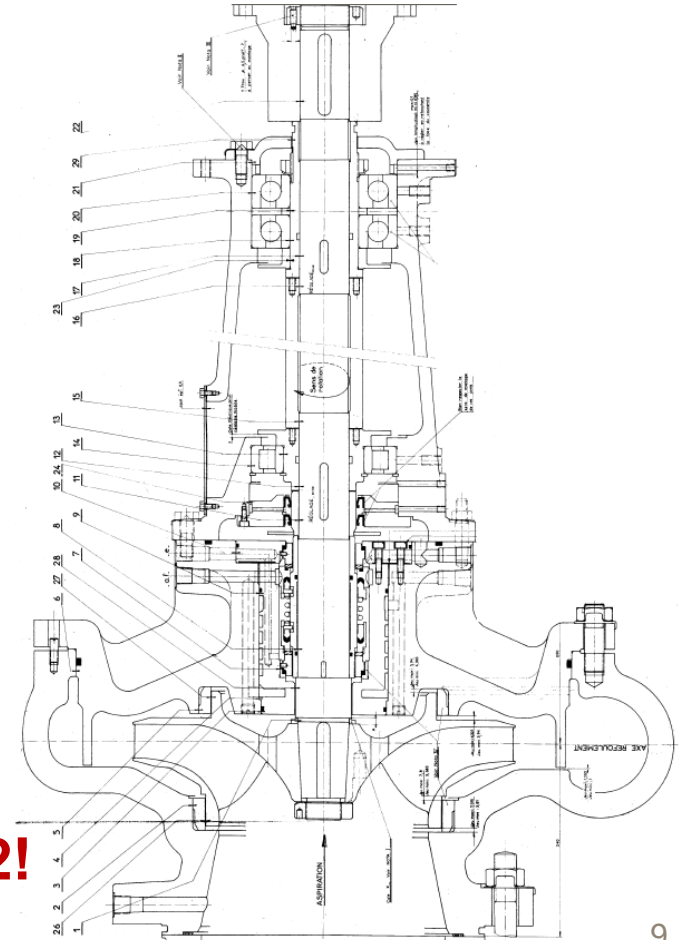

# Design Objectives

- **NPSH**

- ❖ Improve NPSH3 margin ( $F_{\text{NPSH3}}$ )

- Lower NPSH3  $\geq 0.5$  m @ 683 m<sup>3</sup>/h (1470 r/min)

- ➔  $F_{\text{NPSH3}} \geq 1.15^*$

- ❖ This desired NPSH3 improvement translates to a design suction specific speed of  $N_{\text{ss}} \geq 11,700$  (USCU)

\*Note:  $U_{\text{eye}} = 20$  m/s, indicating more margin would be better/recommended, but for this case not feasible



# Design Objectives

- **QH**

- Rated head: 69 m @ 682 m<sup>3</sup>/h
- Stable operating window from 80 – 900 m<sup>3</sup>/h
- Maximum flow head requirement (900 m<sup>3</sup>/h): 61 m
- New QH curve within –0% / +7% of old QH



# Design Objectives – Acceptance Criteria

- **Vibration** (bearing housing)
  - ❖ ISO 2056:1976 / **VDI 2056:1964**
    - 80 – 300 m<sup>3</sup>/h: **4.5** mm/s RMS
    - 300 – 900 m<sup>3</sup>/h: **2.8** mm/s RMS

Vibration behavior	M	G	T
Good	1.1	1.8	<b>2.8</b>
Usable	2.8	<b>4.5</b>	7.1
Still admissible	7.1	11.2	18
Inadmissible	> 7.1	> 11.3	> 18

# Design Objectives – Acceptance Criteria

- **Pressure pulsations**

- Suction and discharge pulsations less than 3%

- **Capacity fluctuations**

- Less than 3%



Provided that benchmark test (original pump) meets these criteria; otherwise benchmark test is determinative

# CFD Study

- The CFD study assisted in:
  - Benchmarking hydraulic performance of the existing design (prior to testing)
  - Evaluating new (impeller) design iterations
- Basis for new design was selected from database of existing impeller hydraulics with known performance (12,000 Nss)
- Existing pump waterways were modelled from 3D geometry scan
- New impeller designs were modelled directly in 3D CAD



# CFD Study

## 3D CAD Model

- **Impeller**
- **Casing**
- **Suction elbow**

Model includes all internal flow (leakage) paths:

- Impeller eye wear ring
- Impeller back wear ring
- Impeller balance holes

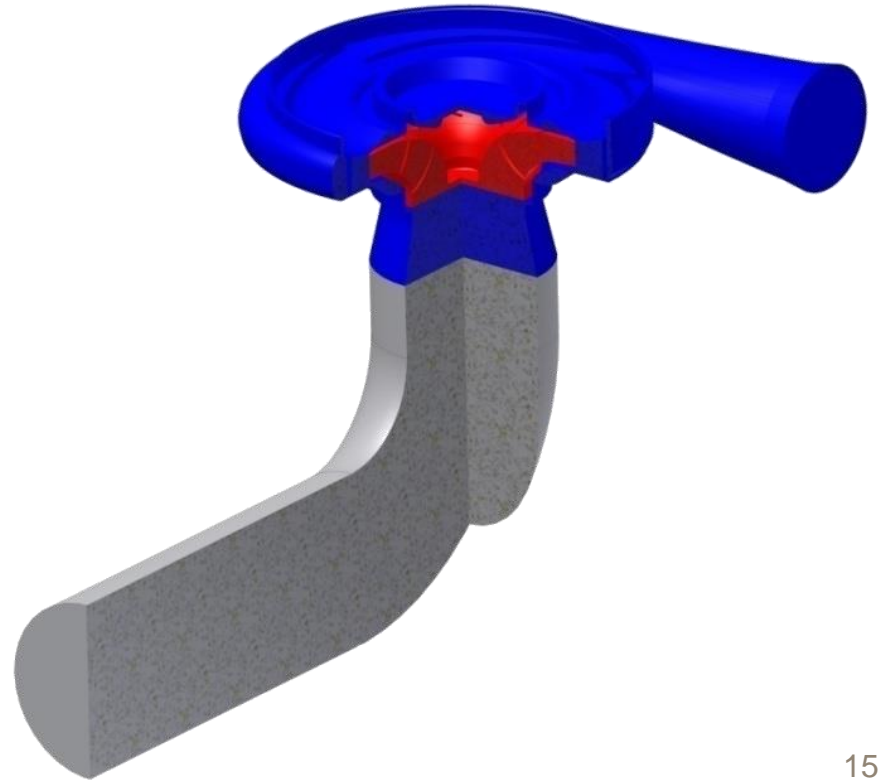

# CFD Study

## Computational Grid

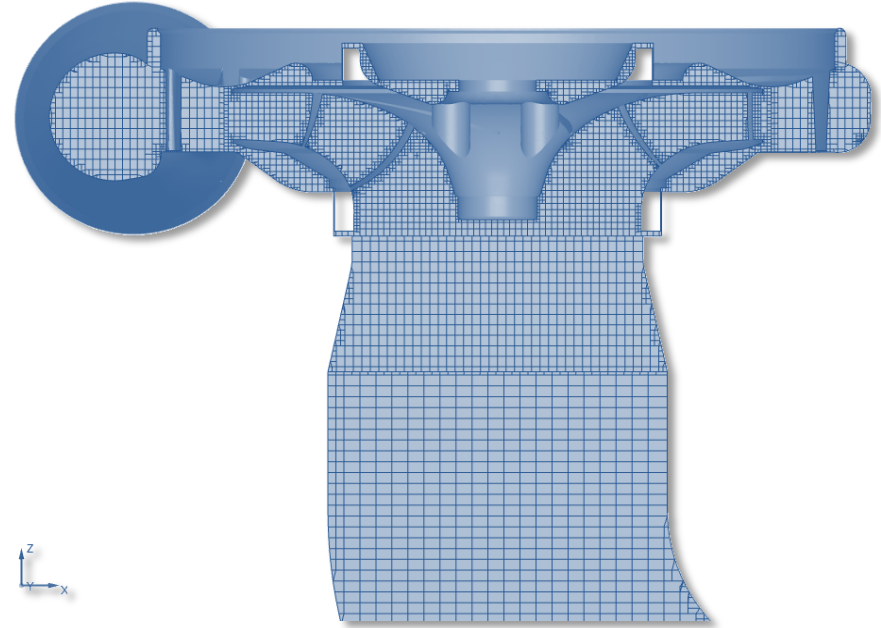
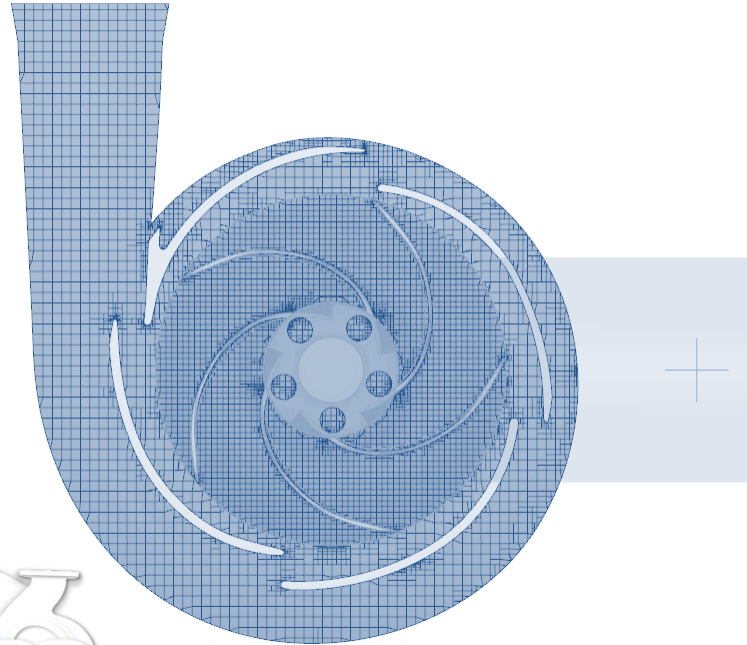

(Binary Tree Mesh)



# CFD Study – Outcome

## CFD Simulated Pressure Pulsation (transient simulation)

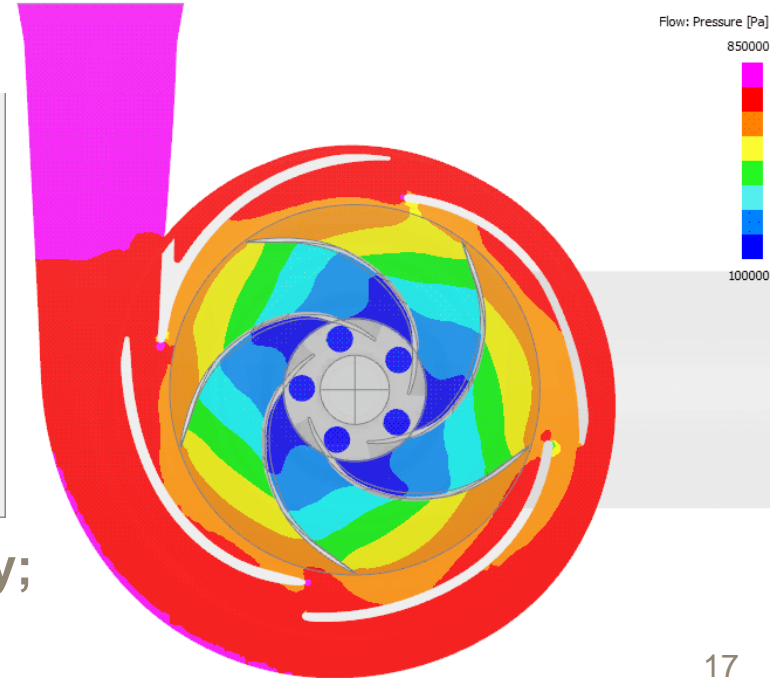
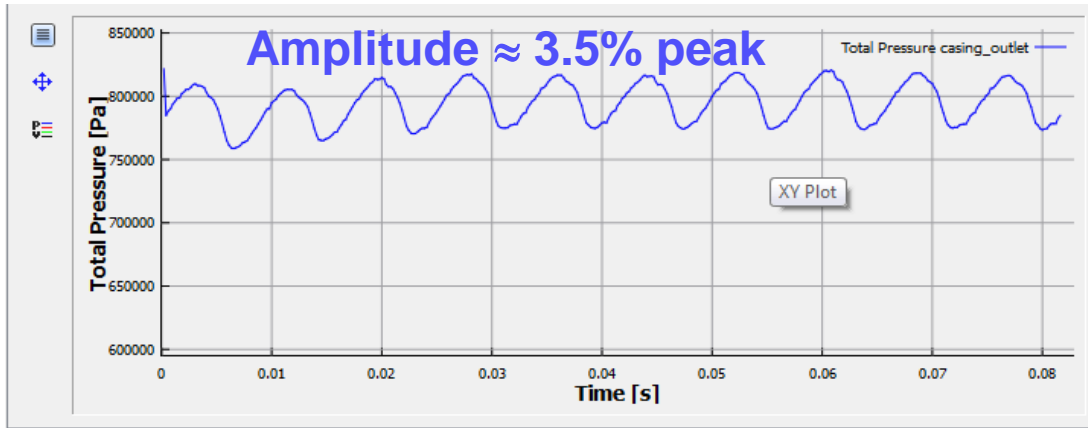

Existing impeller @ rated capacity;

$P_{\text{total, inlet}} = 1.0 \text{ bar(abs)}$



# CFD Study – Outcome

- ▲ Benchmark Test Data (TDH)
- TDH existing
- TDH new
- NPSHi existing
- NPSHi new

**Q<sub>duty</sub> @ 60 % BEP**

**BCP @ same flow for both designs**

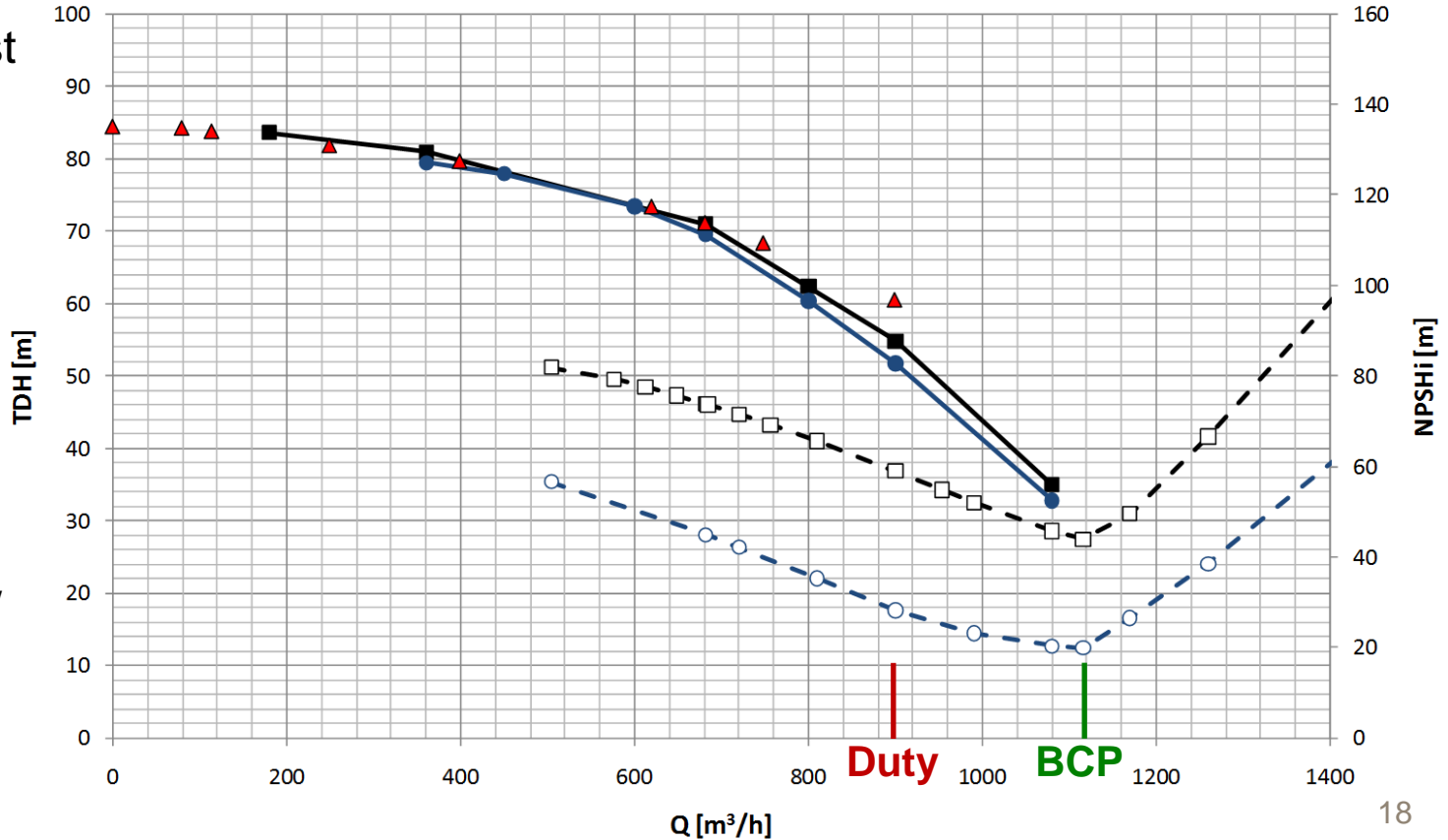

# CFD Study – Outcome

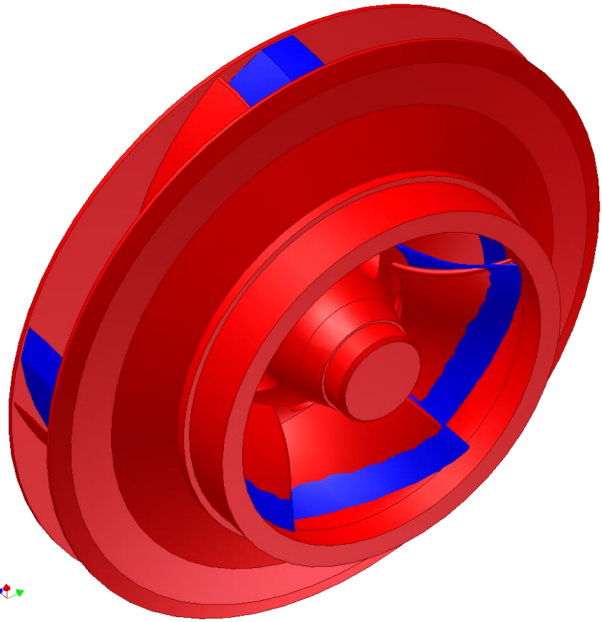

- TDH from CFD compares well with benchmark test, but shows under prediction at high flows
- Incipient cavitation NPSH of new design is much better, indicating that lower NPSH3 can be expected for the new impeller
- Actual performance (including pulsation measurements) to be determined from testing of (rapid) prototype impeller

**Existing** vs. **New**



# Experimental Testing

- **Instrumentation**

- Electromagnetic flow meter
- Tachometer (speed pickup)
- Calibrated test motor (power)
- Pressure transducers

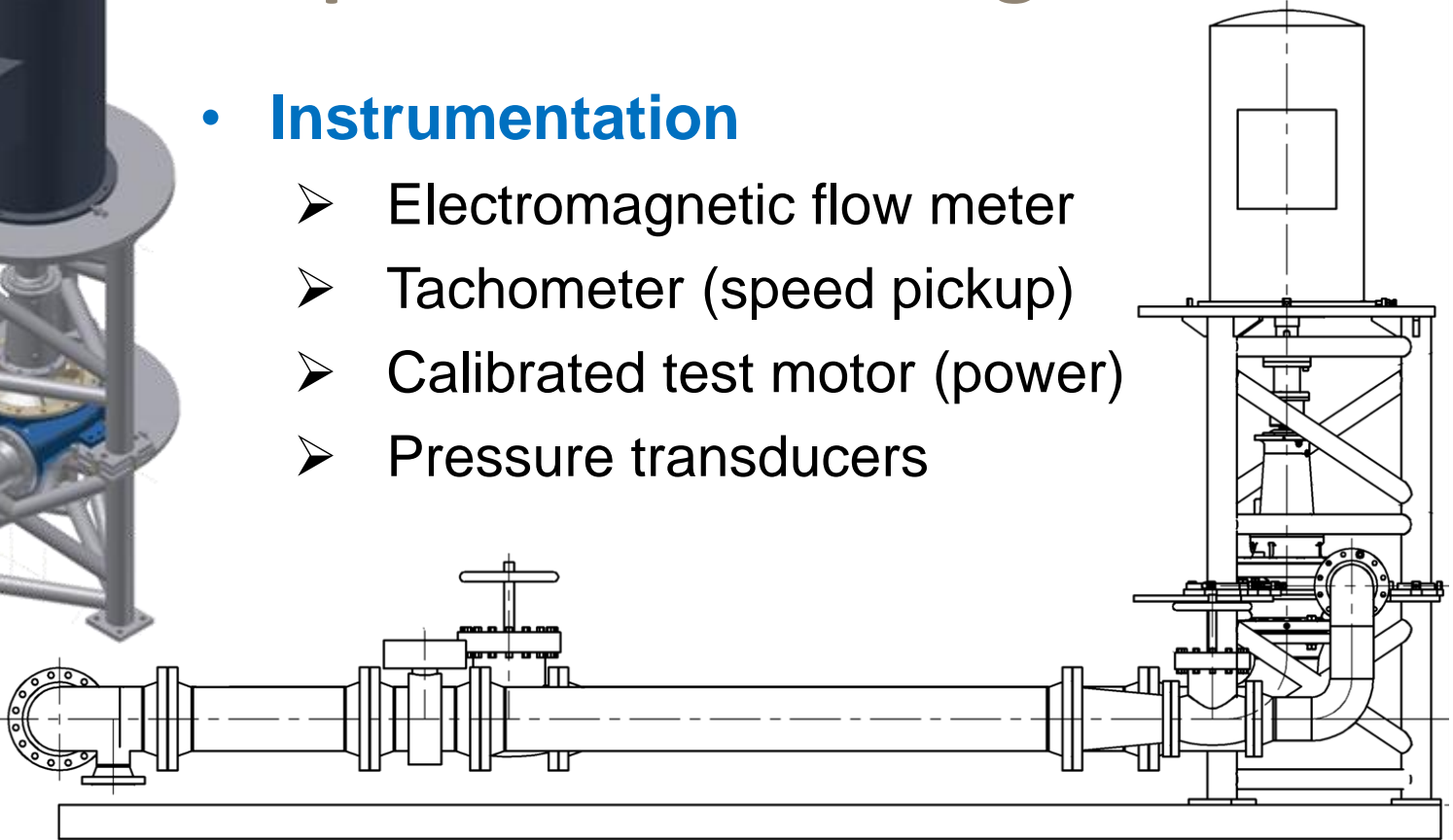
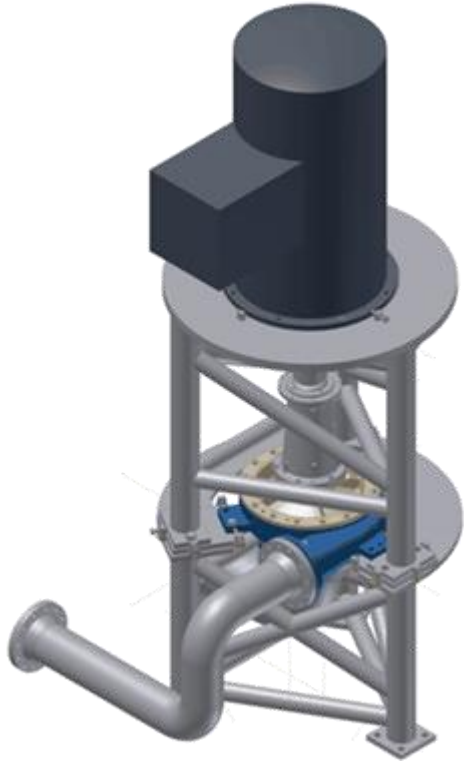

# Experimental Testing

- Temperature controlled test loop with injection cooling
- Performance testing in compliance with Hydraulic Institute
  - ANSI/HI 14.6-2016

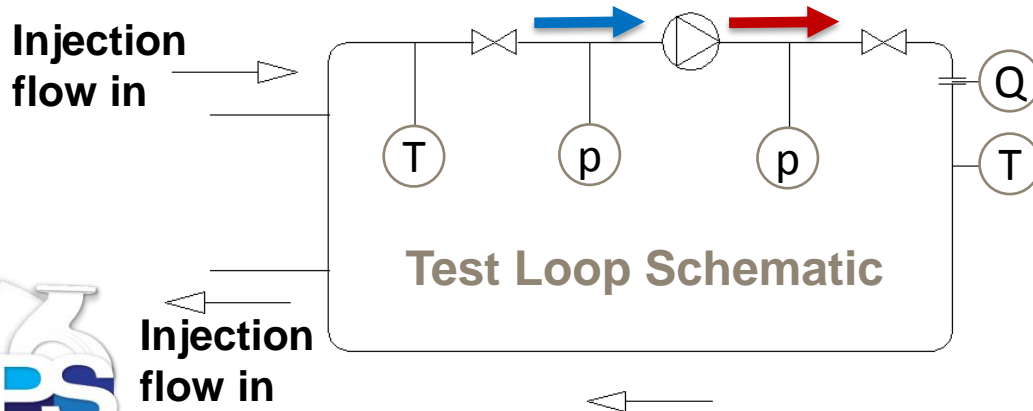

# Experimental Testing

## Impellers Tested\*

- Original impeller
- Original impeller with **plugged balance holes**
- New impeller
  - Initial new design
  - Design modifications

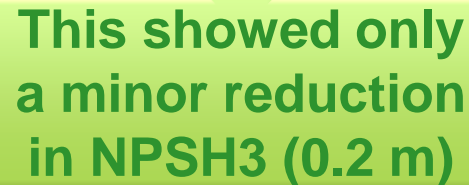

This showed only  
a minor reduction  
in NPSH3 (0.2 m)

\*Prior to each test a vacuum test was conducted on pump and test loop to check sealing of gaskets



# Results – Head Characteristic

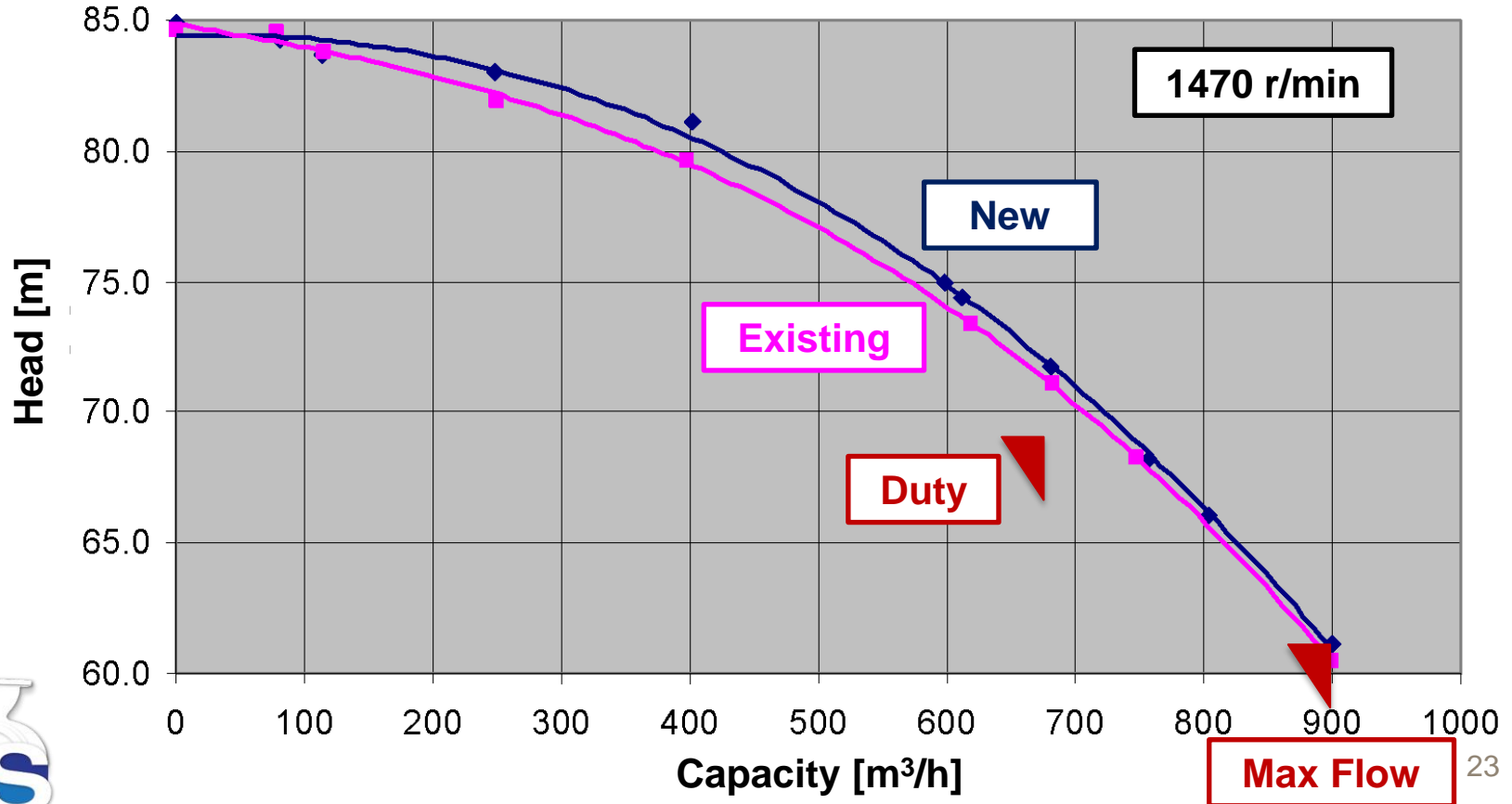

# Results – NPSH3

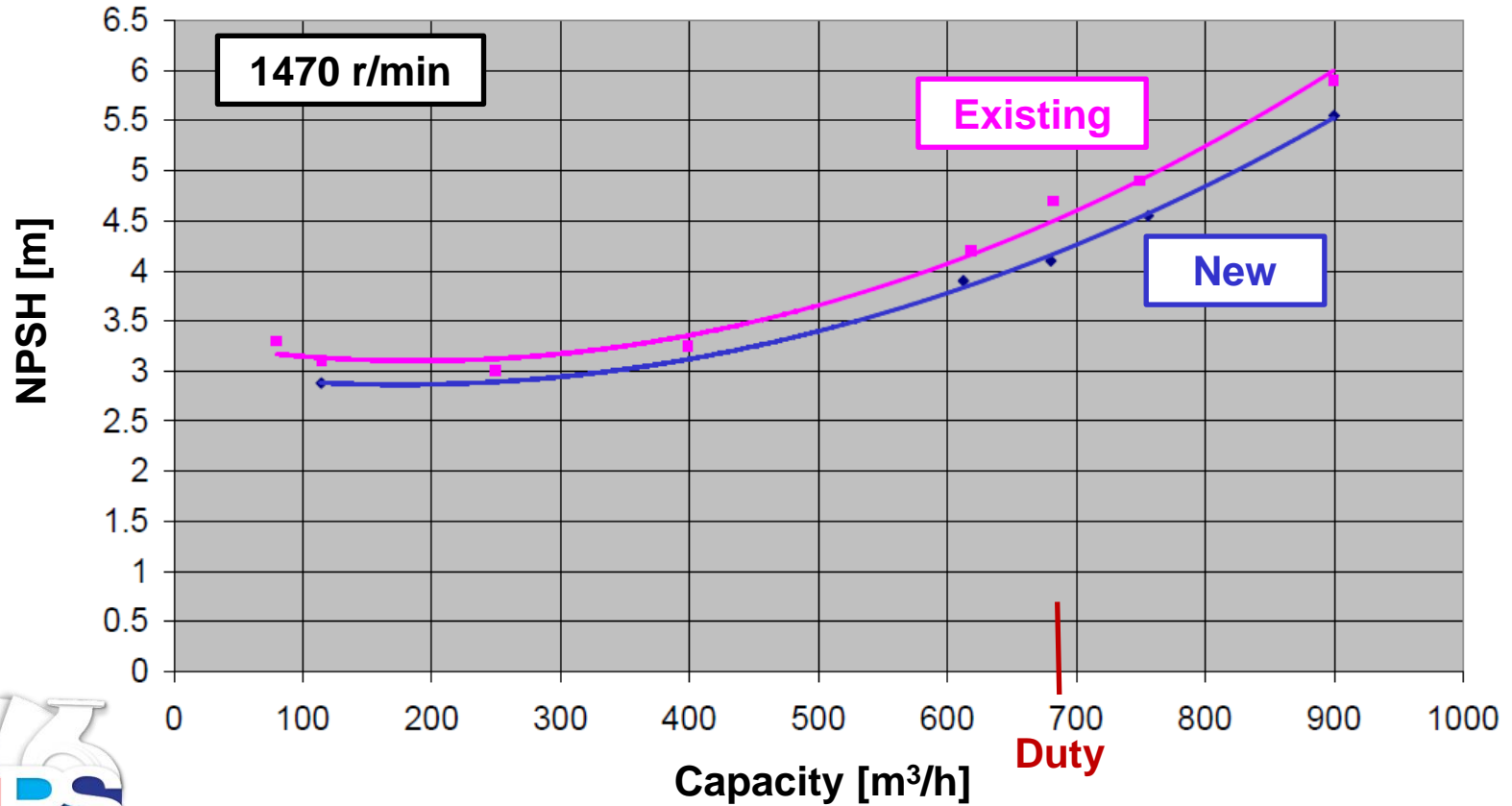



# Results – NPSH10

## Special test

- NPSH10
- Original impeller
- Safety measure pending the upgrade (customer request)
- Marking limit of negative NPSH3 margin

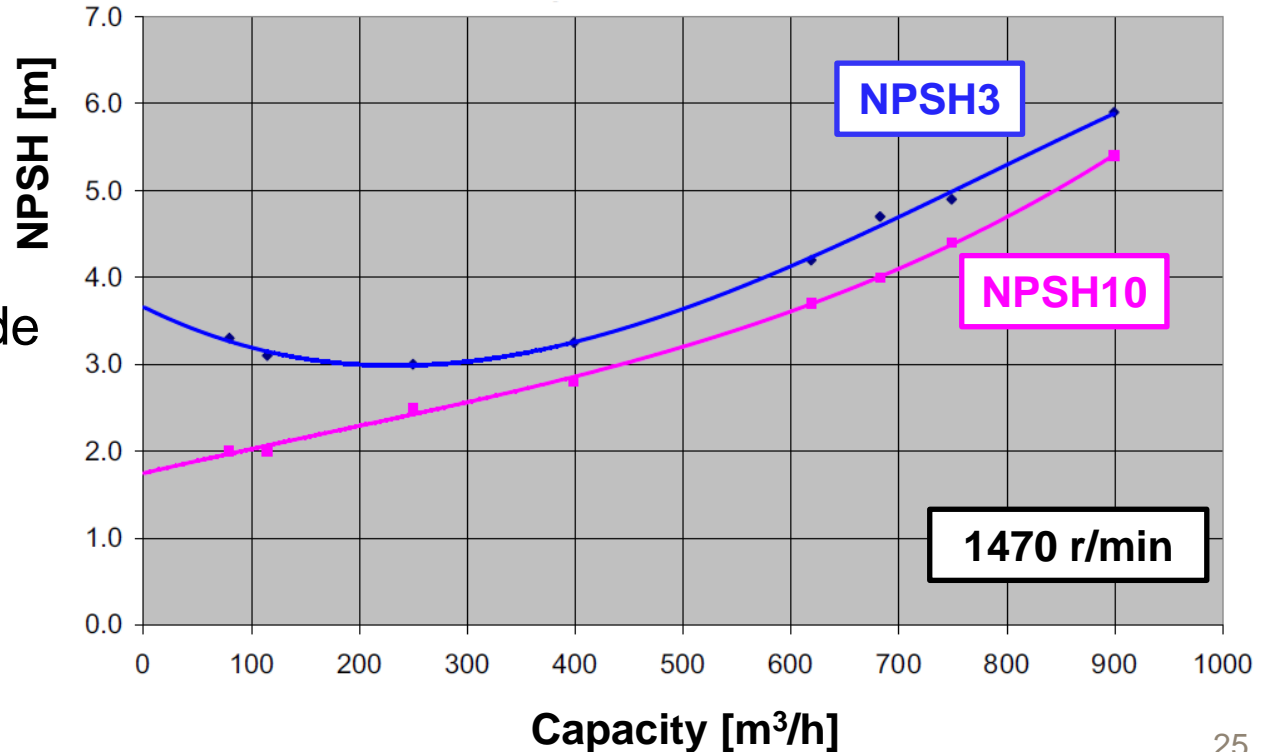

# Concluding Remarks

- New impeller developed by design iterations, starting from existing reference hydraulic
- CFD was used to map hydraulic performance of existing impeller and new design
- Final design was manufactured by rapid prototyping and actual improvement in NPSHR(NPSH3) was demonstrated by test (Existing vs. New)
- Plugging impeller balance holes showed little improvement in NPSH3



**Thank you for your attention**

**Questions?**

