

Proceedings of the Second Middle East Turbomachinery Symposium
17 – 21 March 2013, Doha, Qatar

Gas Turbine Fuel and Fuel Quality Requirements for use in Industrial Gas Turbine Combustion

Michael Welch

Industrial Marketing Manager
Siemens Industrial Turbomachinery Ltd
LN5 7FD, Lincoln, England



Mike Welch is Industry Marketing Manager – Oil & Gas for Siemens Energy Oil & Gas Industrial Power. Based in Lincoln, UK, Mike is responsible for promoting Siemens' ranges of Gas Turbines and Steam Turbines in Oil & Gas applications around the World.

Mike has an Honours Degree in Electrical and Electronic Engineering from Loughborough University of Technology and has worked in both Sales and Engineering roles with Rotating Machinery for 25 years. Mike is a Member of the Institute of Engineering and Technology (IET).

Brian M Igoe

Expert Proposal Manager
Siemens Industrial Turbomachinery Ltd
LN5 7FD, Lincoln, England



Brian Igoe has been working in rotating equipment for 30 years. He is an Expert Proposal Manager for the FEED team of Siemens Industrial Turbomachinery Ltd, Lincoln, England. This team is responsible for supporting gas turbine applications including performance, fuels and emissions at the early stages of projects. Brian also provides a range of training both internally within Siemens as well as to external groups. Brian Igoe was awarded a honours degree in Mechanical Engineering from the University of Surrey and a Master degree from the University of Cranfield. In 2011 Brian was elected a Fellow of the Institute of Mechanical Engineers.

training both internally within Siemens as well as to external groups. Brian Igoe was awarded a honours degree in Mechanical Engineering from the University of Surrey and a Master degree from the University of Cranfield. In 2011 Brian was elected a Fellow of the Institute of Mechanical Engineers.

ABSTRACT

For economic and environmental reasons, it is important that gas turbines used in Oil & Gas applications can burn a wide variety of fuels with the minimum impact on the environment. This workshop will examine the types of gaseous and liquid fuels that can be used in Industrial Gas Turbines, and discuss the two basic types of combustion system employed – ‘conventional’ and ‘Dry Low Emissions’ – and the flexibility of these systems to accept different types of fuel. It will also look at common contaminants found in fuels and the impact these contaminants can have on the operability and maintenance of an industrial gas turbine.

Topics to be covered:

- The types of combustion emissions regulated
- Description of a conventional combustion system
- Introduction to Dry Low Emissions combustion systems
- Typical fuel quality requirements
- ‘Pipeline’ quality Natural Gas fuels
- Using Premium liquid fuels (diesel, kerosene)
- Wellhead Gases as a Gas Turbine Fuel
- Biogas fuels - Refinery and process offgases
- Syngas potential
- Natural Gas Liquids and LPG fuels
- Crude Oil as a GT fuel
- Sulphur tolerance
- Metallic contaminants and their impact
- Organic contaminants (tars and asphaltenes) and their impact
- Water in fuel
- Storing fuels correctly

Gas Turbine Fuel and Emission Introduction

Understanding the need to ensure fuel quality is maintained at a high standard is a key to delivering good operation in a gas turbine over long periods of time. However, it is not just fuel that is critical, it is also ensuring all fluids entering the GT are equally kept at a high standard, thus minimising or eliminating all sources of contaminants.

Delivery of fuel and air to the combustor is one thing, but to ensure the condition of both is optimum is critical to achieving clean and stable combustion. Modern gas turbines operate at high temperatures, and use component designs and materials at the forefront of technology, but these are more susceptible to damage if contaminated fuel and air enter the GT through poor operating procedures. This seminar will consider the need to ensure good quality fluids enter the GT, and why it is necessary, for example, to provide air and fuel free of contaminants to ensure the best availability and reliability of the product.

Combustion technology has moved forwards in achieving low emissions without resorting to wet abatement methods. Both conventional and low emissions technologies are covered and reviewed along with basic operating parameters associated with the fuels in question.

The choice of fuels used in GT applications is very wide with the choice based on availability and cost. In some cases fuels may have little or no treatment, in others they may have “added value” which results in the high quality pipeline natural gas that provides the main fuel of choice for gas turbine OEMs and operators alike. Gas Turbines can and do operate on a wide range of fuels, some of which are shown in table 1 below, but the impact that such fuels may have on turbine life has to be recognised.

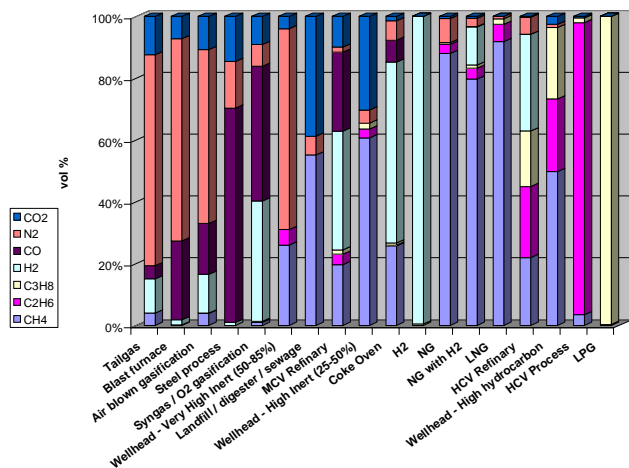

Table 1: Range of gaseous fuels

It is not a simple case of saying these fuels are acceptable or not, but understanding the details of these fuels, such as the composition [hydrocarbon species in the case of a gaseous fuel, inert species, contaminants, water vapour, ...]. Detailed analysis of the fuels is necessary to determine key parameters of the fluid, such as delivery, storage and conditioning as well as key features of the fuel itself, including lower heating value, Wobbe Index, dew point and density. Understanding all of these provides the OEM and user with indicators that the fuel entering the GT is suitable and can result in good operation across a wide range of loads and ambient conditions. It is also important to determine and understand the products of combustion and impact on the environment. Exhaust emissions are highly regulated in many parts of the world and even those areas that up until recently had no requirements have started to introduce standards or guidelines which need to be noted during the application assessment stage.

Types of combustion emissions regulated; Legislation, OEM and Customer Requirements

The US Clean Air Act set new standards for emissions compliance, which included stationary power plants where gas turbines were included. Therefore, over the last 25 years, increasing pressure was placed on the gas turbine OEMs to develop less polluting products. The European Union (EU) and other countries soon followed with more demanding legislative requirements, thus low emissions became the norm and not the exception. There are a wide variety of pollutants to consider, from Oxides of Nitrogen, NOx, Carbon Monoxide, CO and unburnt hydrocarbons, UHC, {1} In addition, the major gas turbine OEMs, along with a large number of Oil & Gas companies, have their own policies with regard to the environment and will offer or specify low emission equipment even in locations where no formal legislation exists, or is set at a higher level. The result of all of these drivers is to make the Dry Low Emissions or Dry Low NOx (DLE/DLN) combustion system the primary combustion system of choice.

Available Combustion Systems

Two main types of combustion system are available and widely used in gas turbines: one based on the ‘conventional’ diffusion flame; the second uses lean pre-mix technology targeting low exhaust emissions signature. These are offered in both annular and can-annular arrangements.

Conventional Combustion

Before the introduction and widespread use of low emissions combustion designs the only type of combustion system was based on diffusion flame, referred also as conventional combustion (figure 1). These operate at high primary zone temperature, circa 2500K, which results in high thermal NOx formation. Reduction of the flame temperature results in lower NOx formation. With diffusion flame combustion this can be achieved by injection of diluents such as water or steam into the primary zone. This has been successfully employed over many years across product ranges by many of the gas turbine manufacturers. Generally such combustion systems have been more tolerant with fuel types. Use of either water or steam injection into the heart of the combustor quenches the flame, thus reducing the production of NOx emissions. Different OEMs use differing methods in water or steam injection, but all recognise the impact each has on reliability and life cycle costs.



Figure 1: Conventional or Diffusion flame combustion hardware

Figure 2 shows a comparison from injecting water or steam in the primary zone with the newer dry low NOx solution, {2}. Other factors to note with wet injection are the need for large quantity of de-mineralised water and the impact on service regime, with more frequent planned interventions. Where a service retrofit of existing gas turbines was made to include DLE combustion, the environmental benefit was significant, offering almost a 5 times reduction in NOx emissions compared to previous abatement system employed (figure 3).

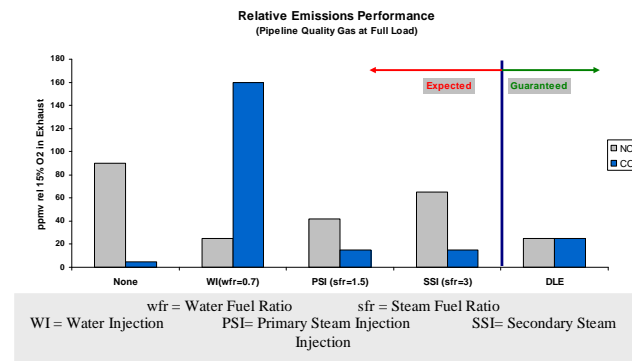

Figure 2: Effects of wet injection on diffusion flame combustor, compared to DLE

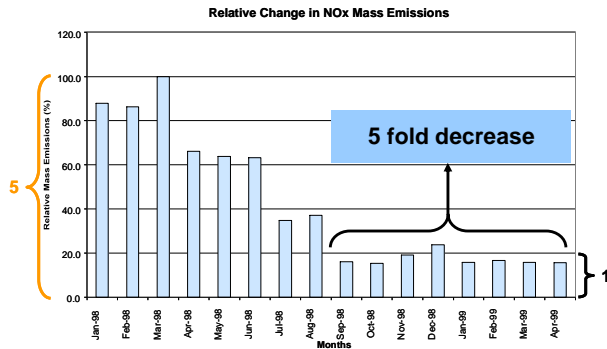

Figure 3: Effect of conversion of multi-engine site from conventional to DLE combustion configuration

Introduction to Dry Low Emissions combustion systems

The modern approach to achieve lower primary zone temperatures without resorting to wet diluents is with lean pre-mix combustion. Dry Low Emissions (DLE) or Dry Low NOx (DLN) combustion systems address the production of NOx at source with a design that does not rely on injected diluents, hence the term “dry”. Of the 4 promising technologies identified:

- 1: Lean-premixed pre-vaporised combustion
- 2: Staged Combustion
- 3: Catalytic Combustion
- 4: Rich-burn lean quench combustion.

the lean premixed system is the one that has been developed by several gas turbine OEMs as the combustion system of choice with millions of operating hours recorded. All these methods reduce the production of NOx by reduction of the reaction temperature.

Lower NOx formation has been achieved by combusting the fuel in an excess of air, hence “lean” pre-mix combustion. NOx production increases exponentially with temperature, therefore it is critical to ensure air and fuel is well mixed. During the early design and development work, there was as much attention devoted to achieving a homogeneous mixture, and burning this mixture without detrimental impact on combustion and turbine hardware.

A lean pre-mix combustor design comprises 4 main features:

- Fuel / air injection device
- Stability device
- Pre-mixing zone
- Flame stabilization zone

These features are covered and discussed in more detail later.

Meeting emissions requirements is only one aspect of combustion design. It has also to meet operational criteria, including: component life; flexible fuel operation; reliable starting; reliable switching between fuels; reliable transient response; and all this without excessive cost.

Methods of reducing NOx Emissions

There are three main ways for NOx formation

- thermal NOx
- prompt NOx
- fuel bound NOx (FBN)

Of these, FBN can only be influenced by removal of nitrogen bearing compounds in the fuel, something outside the scope of this paper. Of the other two, thermal NOx is by far the more dominant. Thermal NOx is produced by the reaction between Nitrogen and oxygen in the air as described by Zeldovich, {3}. This reaction takes place above 1700K and the rate increases exponentially as temperature increases (figure 4).

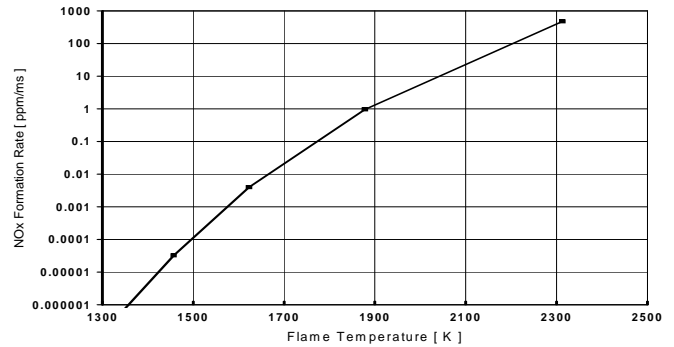

Figure 4: NOx formation rate, from Zeldovich

The easiest way of controlling unwanted emission to atmosphere is to prevent its production in the first place through changes to the combustion design, leading to the use of dry low emissions technology (DLE) or Dry Low NOx (DLN). Initially NOx control resulted from the injection of steam or water into the primary zone of the conventional diffusion combustor, suppressing peak combustion temperatures and hence formation of NOx.

DLE design

Figure 5 and 6 show lean pre-mix DLE combustion system design as released into production in the early 1990’s and from 2000, {4, 5}. These are can-annular solutions, although some manufacturers apply lean premix within an annular combustion configuration.

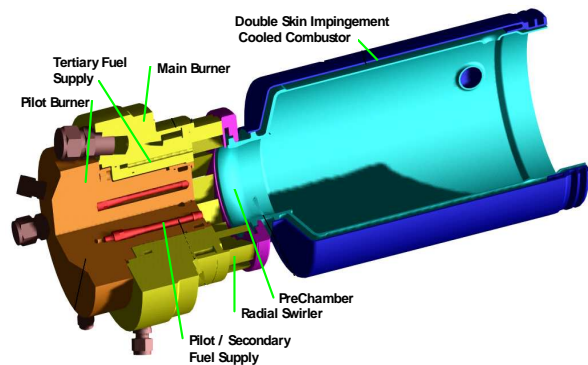

Figure 5: DLE combustion system design circa 1995

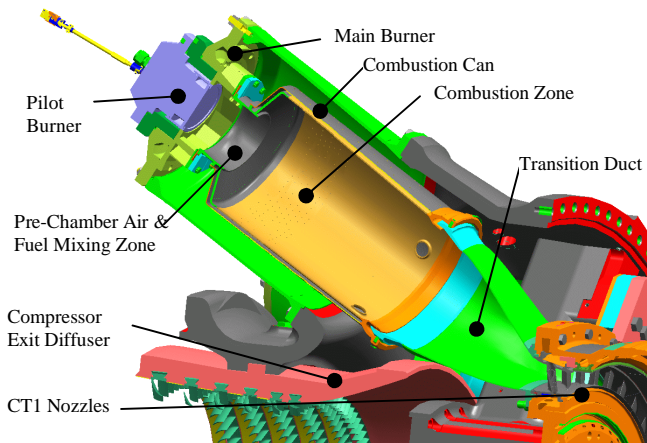

Figure 6: DLE combustion system design 2000

A single combustion chamber is mounted around the outside of the compressor exit section of the gas turbine, with multiple burners mounted through engine casings into holes in the annular combustor, as shown in figure 7 below.

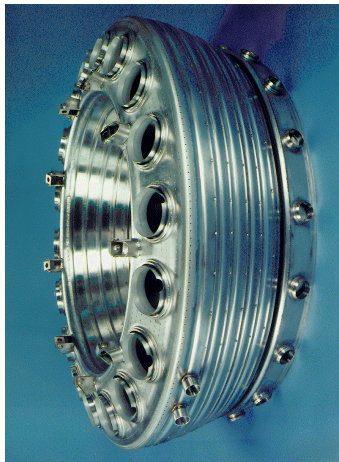

Figure 7: Annular Combustor with 3rd generation DLE burner

Diffusion flame comparisons with DLE combustion systems

In order to produce low NO_x and low CO the homogeneous flame temperature within the combustor must be controlled between strict limits. Conventional diffusion flame combustors (figure 8) have very high temperature primary zones due to high turbulence region promoting mixing and result in temperatures in excess of 2500K.

These high temperature regions lead to high NO_x production rates, resulting in diffusion flame combustors producing NO_x emissions typically greater than 300ppmv at 15% O₂. In order to reduce NO_x levels either the temperature within the

combustor has to be lowered or the NO_x must be removed after the turbine.

Improvements in mixing the fuel and air to achieve a homogeneous mixture whilst at the same time 'leaning out' the mixture within the DLE combustor, achieves the desired effect of a more uniform and lower peak combustor temperature, thus resulting in low thermal NO_x production, figure 9.

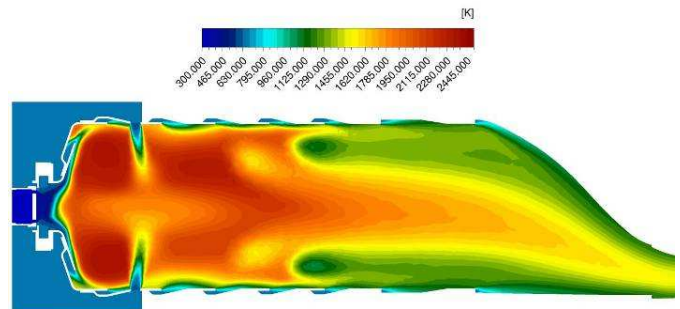

Figure 8: CFD calculation of temperature distribution within a diffusion flame combustor

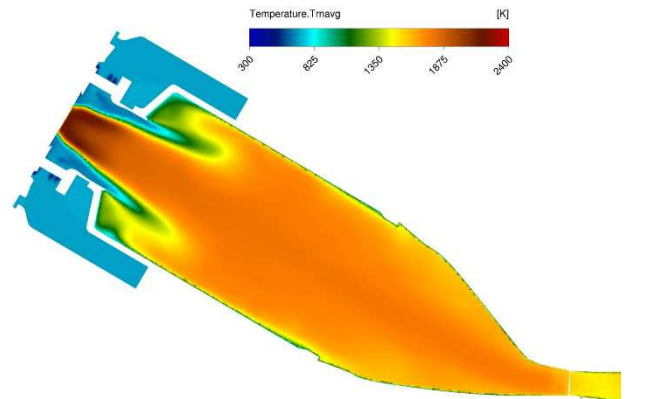

Figure 9: Computation of temperature (in Kelvin) distribution in a DLE lean premixed combustor

Dry Low Emissions Combustion

The design approach by one OEM is highlighted in Figure 10 highlights the use of scaled combustion geometry across the product portfolio and shows the application of a can-annular combustion hardware.



Figure 10: Scaled hardware design across the product

portfolio

A common design approach was adopted where scaling and adjustments for air flow have been applied depending on the rating and combustor numbers used in the GT model.

The combustor consists of three main sections (figures 5 & 6):

- i) Fuel injection device - the pilot burner - houses the pilot fuel galleries and injectors for both gaseous and liquid fuel
- ii) Main fuel injection device - the main burner - houses the main air swirler and main gas and liquid fuel systems
- iii) The combustor - flame mixing and stability device - includes a narrow inlet feature, called the pre-chamber. The combustor is a double skin construction and cooled via impingement cooling with this air exhausted into the combustor through dilution holes downstream of the main reaction zone.

A transition duct, located downstream of the combustor, conditions the flow from the circular combustor exit to a sector of the turbine entry annulus.

Figure 11 shows a schematic of the combustion concept. The main combustion air enters through a single radial swirler at the head of the combustor. Flow turns through 90degrees into the pre-chamber followed by a sudden expansion into the combustion chamber. The swirl number is sufficiently high to induce a vortex breakdown reverse flow zone along the axis. This is termed the internal reverse flow zone. In this design concept the reverse flow zone remains attached to the back surface of the combustor thereby establishing a firm aerodynamic base for flame stabilisation. In the wake of the sudden expansion, an external reverse flow zone occurs with flame stabilisation in the shear layers around the internal and external reverse flow zones, {6}.

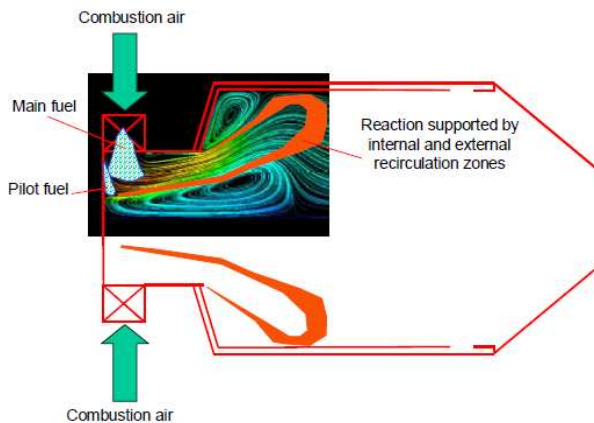

Figure 11: Schematic of the Dry Low Emission combustor concept

- Fuel, both gas and liquid is introduced, in two stages:
- Main, which results in a high degree of 'premixedness' and hence low NOx emissions
 - Pilot, which is steadily increased as the load demand decreases in order to ensure flame stability

The pilot is arranged such that as the pilot fuel split increases, the fuel is biased towards the axis of the combustor.

Describing each element of the DLE in more detail and referring to figures 5 and 6 shown earlier:

Pilot burner

The pilot burner provides fuel for ignition and transient operation, with a small percentage used at full load for stability purposes. This allows for rapid response during load rejection conditions, for example a power generation application where a circuit breaker trips and the turbine load changes from exporting electrical power to the grid to simply providing sufficient power to meet customer local demand.

An ignition source is mounted in each pilot burner, along with a thermocouple to monitor the temperature of the face of the burner. For dual fuel units, a separate liquid fuel lance is located through this burner and provides fuel for ignition and transient operation. [This liquid lance is fully accessible from outside and facilitates maintenance requirements.]

Main burner

Flow increases as speed and then load is increased. This provides the pre-mixing via the radial swirler and numerous gas injection ports. The swirlers are of a fixed design with no local moving parts. Reliance on control of fuel is necessary to achieve both load and ambient temperature control

Liquid core

Lying inside of the main swirler/burner, with pilot burner located inside of this, is the liquid core for when a dual fuel arrangement is required. For gas fuel only configuration, this core is replaced with a blank ring. As with gas fuel, liquid is injected through one of six injector nozzles equally spaced around the core, and lying inboard of the gas injection point in alternate swirler vanes. The good pre-mixing of the fuel with the high velocity air results in good liquid fuel emissions characteristics.

Combustion liner

The main swirler/burner is mounted at the head of the combustor. This comprises a double skin liner, the outer skin controlling the cooling air feeding the annulus between inner and outer liner. The head of the combustor locates the pre-chamber and is where the fuel is mixed prior to ignition

Transition duct

This duct controls and directs the hot combustion gases towards the first stage nozzle and typically includes effusion cooling.

Materials:

All components of the combustion hardware are manufactured from conventional materials typically used in this part of the gas turbine. Burners are routinely made from stainless steel, with the application of a thermal barrier coating in key areas. Combustion chambers are manufactured from Nimonic steels with thermal barrier type coatings applied to the inner liner surface.

Having considered the combustion system it is now important to consider in more detail fuel and fuel quality.

Gas turbine Fuels and Fuel Quality

Modern highly efficient gas turbines rely on high-quality alloys to allow increased firing temperatures to be achieved, whilst

still maintaining acceptable product life. To ensure this is achieved, far more attention on the use of the fluids entering the gas turbine is necessary, including air, lubricating oil and fuels. The subject of fuel quality is a major topic in its own right and therefore some of the fundamental requirements associated with fuel quality are discussed, along with potential issues associated with poor fuel quality.

All Gas Turbine OEMs, provide comprehensive specifications to cover the quality of fuel permitted for use in the gas turbine. These are used to ensure fuel quality is defined at the onset of a project and throughout the lifetime of the turbine and are prepared for good reason. To ensure acceptable turbine operation is achieved with little or no impact on major turbine component life, it is necessary to understand fuel composition and the supply conditions in more detail. Identification of contamination has become particularly necessary as this can have a detrimental impact on the exotic materials used in turbine blading.

The choice of gaseous fuels as a primary fuel for use in gas turbines is dictated by widespread availability and low price. Compositions of gaseous fuels can vary quite widely, from those taken directly from wells which can contain high amounts of heavier hydrocarbons, to those containing non-combustible species (such as nitrogen, carbon dioxide, argon ...). In some cases quantities of hydrogen sulphide may be present, which, left untreated, can produce sulphur oxides in the exhaust, and, more significantly, can combine with halides to form compounds which readily attack the exotic alloys used in turbine blading, resulting in premature component failure. Gaseous fuels can contain a wide variety of contaminants such as:

- Solids
- Water
- Higher hydrocarbons
- Hydrogen sulphide
- Carbon dioxide
- Carbon monoxide
- Hydrogen

It is important to provide the OEM with a comprehensive fuel composition in order to determine the suitability of such fuels. Issues can be identified at this early stage to allow preventative measures, such as fuel treatment, to be taken.

Higher hydrocarbons influence the hydrocarbon dew point, hence high supply temperature is required. If the temperature is not maintained then liquid dropout (condensate) will result and can cause problems in the fuel system, or, more seriously, impinge on combustor surfaces leading to localized burning and component failure, such as indicated in figure 12 LHS (occurred very rapidly and resulted in engine shutdown).



Figure 12: DLE Pre-chamber damage as the result of heavy hydrocarbon carry over and oxidation

Hydrogen sulphide combustion results in sulphur oxides in the exhaust (hence potential for acid rain). Of greater concern is the presence of alkali metal halides, such as sodium chloride or potassium chloride, and water vapour. These result in the formation of alkali sulphates, giving rise to aggressive corrosion attack of the nickel alloys used in modern turbine blades (figure 12 RHS). This example is after several thousands of operating hours.

Gaseous Fuel Assessment Criteria

A comprehensive assessment of gaseous fuels is necessary with a number of factors used to assess the suitability. Some of these discussed below can be inter-related, such as the presence of water and solid contaminants.

Wobbe Index; Temperature Corrected Wobbe Index

Pipeline quality gas fuels contain mostly methane, with small quantities of ethane, and typically fall into the range 37 – 49MJ/m³ Wobbe Index.

Wobbe Index (WI) is one of the parameters used to assess fuel and allows a direct comparison of different fuels to be made based on heat content. Wobbe Index (number) is the Net (lower) calorific value of the fuel divided by the square root of the fuels specific gravity.

Wobbe Index

$$WI^0 = CV_v^0 / \sqrt{SG^0}$$

Where CV_v^0 = net calorific value (MJ/m³) at standard conditions (288K, 1.013bara)

SG^0 = specific gravity at standard conditions

$$= \rho_{fuel} / \rho_{air}$$

where ρ_{fuel} and ρ_{air} are at standard conditions (288K, 1.013bara)

Fuels can and are often provided at different supply conditions. Therefore the use of Temperature Corrected Wobbe Index (TCWI) becomes an important aspect when reviewing fuels. Gas fuels containing water and or higher hydrocarbon species will result in higher dew point requirements, hence the need to provide a set amount of superheat margin, ensuring the gas remains in vapour phase at all times.

$$WI^T = WI^0 \sqrt{288 / T_{fuel}}$$

Where:

T_{fuel} is temperature of fuel at turbine skid edge(K)

WI^T = Temperature Corrected Wobbe Index

WI^0 = Wobbe Index at standard conditions, 288K

Fuels with visually different compositions may have the same Wobbe Index and therefore same heat content. However, other factors such as dew point need to be evaluated.

Dew Point and supply temperature

Gaseous fuels comprise a variety of hydrocarbon species, each of which has a unique “dew” point temperature, i.e. the temperature at which the gas condenses producing liquids, and

those fuels which also contain water will have in addition a water dew point (figure 13), [7]. Thus it is possible to determine the dew point for a known gas at a given pressure. It is normal to apply a margin of superheat over the calculated dewpoint, to prevent condensate or liquid drop out, which is usually a minimum of 20°C, but may be higher depending on OEM, with 25-30°C as recommended for example by ASME B133.7. Fuels which contain higher hydrocarbon species require a higher margin of superheat to be applied.

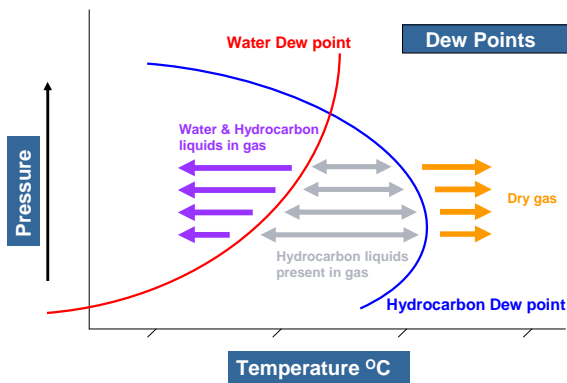

Figure 13: Water and Hydrocarbon Dewpoint

Water

Pipeline quality gas fuels are usually clean and dry, but there are many occasions when fuels contain water. Presence of water can be problematic:

- Free water in the presence of hydrogen sulphide or carbon dioxide can form acids which can be highly corrosive to the fuel system and associated pipework
- Water may contain undesirable water-soluble contaminants

Removal of water using best industrial practices should be considered.

Higher Hydrocarbon Species

The presence of higher hydrocarbon species impacts the dew point, and hence the supply temperature. Higher hydrocarbon liquids, or condensate, when passed into the combustor combust in an uncontrolled manner:

- condensate is un-metered; result in uncontrolled combustion
- detrimental effect on operation, safety
- can result in both combustion hardware damage or failure as well as downstream hot gas path turbine components
- Burner gas gallery and passage blockage due to carbonization

Temperature adjustment of fuels has a potential added benefit:

- Allows some richer fuels to be supplied at a temperature beyond what is required for dew point control
- Trace heating and lagging of the gas supply pipework and fuel system would be required

Contaminants in gaseous fuels

Water is one contaminant already discussed, but there are other contaminants that are often met and need to be considered

Carbon Dioxide

Can react in the presence of moisture producing a weak acid, but mostly acts a diluent reducing the heat content available in the fuel.

Hydrogen sulphide

Hydrogen sulphide is highly toxic and can pose unique challenges to operators as well as in the operation of gas turbines. Besides specific health and safety requirements H₂S (also sulphur in liquid fuels) can combust producing SO_x emissions to atmosphere, which react in the presence of moisture resulting in weak acid production (acid rain). Where SO_x legislation exists, treatment of the fuel at source to remove or lower H₂S (or sulphur in liquid fuels) content will be required.

In addition in some applications where sodium or potassium may be present, such as off-shore, then further assessment will be required. Reaction of these species with sulphur result in the production of sodium and potassium sulphates which are highly corrosive to modern materials used in the hot gas path components, such as turbine nozzle and rotor blades.

Hydrogen and Carbon Monoxide

These readily combust and require special understanding before acceptance as a GT fuel. Both exacerbate combustor flame speed, and can result in flashback, where the flame velocity exceeds the local combustor velocities. This makes these types of fuels less suited for lean pre-mix type combustion systems. However, conventional diffusion flame combustion systems are more tolerant to such fuels, subject to full assessment and application of appropriate safety measures as required with such fuels.

'Pipeline' quality Natural Gas fuels

Gases extracted from underground sources – wellhead or associated gas – undergo processing resulting in a high quality product that can be used by industrial and domestic users alike. It comprises mostly methane, CH₄, but can contain small amounts of ethane, C₂H₆, and propane, C₃H₈. Inert species such as Carbon dioxide, CO₂, and Nitrogen, N₂, may be present in small quantities. The processing also ensures pipeline gas fuels are dry and free from any moisture.

Gas fuels can originate from oil wells, and termed “associated” gas; gas wells and condensate wells are sources that may be entirely free of crude oil. In all of these cases, the gas requires processing to remove higher hydrocarbon species and gaseous contamination such as hydrogen sulphide, H₂S, and water to ensure gas is clean and dry before it is allowed to enter natural gas pipelines. Strict control on gas specification is made to ensure the gas fuel entering the pipeline from whatever source does not vary significantly.

“Waste” hydrocarbon products from gas processing are themselves valuable. These are often termed natural gas liquids and include ethane, propane and butane for example. Separating these and selling in the open market as, for example LPG, is a good way of ensuring all gases recovered from the

wells is utilized.

Other Types of Fuels encountered for use in Industrial Gas Turbines

Pipeline quality gas fuel has been shown to be the primary source of fuels for gas turbine applications mainly due to its widespread availability and low cost. However, there are many other fuels which are used or considered, especially where pipeline gas is either not available or of insufficient quantity.

Premium liquid fuels

Diesel fuel and Kerosene processed to internationally recognized quality standards are used either on their own or in conjunction with gas fuels (dual fuel operation).

Distillate fuels (No2 Diesel and Kerosene, for example) are processed from crude oil and can be made to a wide range of specifications. Other liquid fuels such as natural gas liquids or higher hydrocarbon liquids, such as LPG (a mixture of propane and butane), are also produced and have been used as a gas turbine fuel, although special consideration is needed in such cases. Figure 14 highlights the range of liquid fuels compared to natural gas.

The suitability of commercially available diesel fuels must be assessed and compared to the OEMs own specification. Several international specifications exist, all with small differences that can make a huge difference in gas turbine operability. Typical Specifications include EN590 and ASTM D975 along with low and Ultra Low sulphur diesels, {8}.

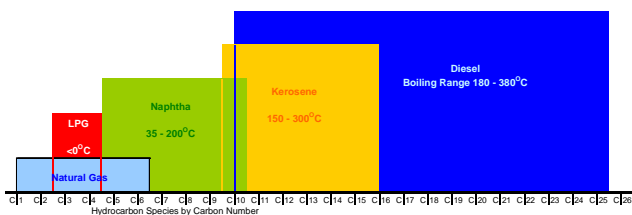

Figure 14: Liquid fuels typical encountered for gas turbine use, compared to natural gas

Alternative liquid fuels to fossil diesel are becoming more widespread, such as paraffinic biodiesel and liquids derived from natural gas, the latter via conversion techniques such as Fischer Tropsch and commonly referred to as “Gas to Liquids” or GTL fuels. Although production quantities are small today these will grow in years to come and either be blended with fossil diesel or be used as a stand alone fuel. Specifications for such fuels are in development, such as CWA 15940:2009, covering Paraffinic bio diesel fuel, {9}.

Wellhead Gases as a Gas Turbine Fuel

Alternative gaseous fuel solutions for gas turbines are used, where little or no added value to raw fuel sources can make strong economic sense. Assessment and use of wellhead or associated gas fuels can allow marginal wells and locations to be developed.

Each fuel is assessed on its merits with some recommendations made regarding minimal cleanliness, water content, dew point control, all of which have been covered in detail.

Biogas fuels

These are weak methane-based gas fuels (can be referred to as medium or low btu fuels) contain high levels of carbon dioxide, CO₂ and or Nitrogen, N₂. They can be naturally occurring or derived for example from the decomposition of waste material (Land Fill Gas - LFG) or the more rapid use of anaerobic digestion (AD) process or Waste Water Treatment Process (WWTP), and can be considered as a useful fuel for gas turbines, {10}. These are sometimes recognized as renewable fuels and can gain some green environmental and economic benefits. There are many examples of gas turbines offering such capabilities. Extended fuels capability based on DLE combustion configuration, operating with high levels of either CO₂ or N₂ content, or both, in the biogas have been developed in recent years. With such fuels it is a requirement of the fuel system to provide sufficient quantity of fuel to sustain stable combustion and be responsive to variations in such fuel sources.

It should be noted and recognized that there is an appreciable increase in flow through the turbine (from combustion air and increased fuel flow) when compared to standard pipeline quality gas fuels. Power output is a function of mass flow through the turbine; the mass flow being the sum of air flow through the compressor and from the fuel source. For medium CV fuels, the fuel mass flow is increased to achieve the required energy content compared to natural gas resulting in an increase in power output.

Refinery; Process Off-gas; Hydrogen Syngas

In the same way off gases from processes, such as a refinery off-gas can also be used. These, however, tend to be hydrogen and Carbon Monoxide rich and special consideration has to be made for these types of fuels.

Syngas also fall into this category, but are mostly derived from the gasification or pyrolysis of various wood or agricultural waste products. These fuels are lower in heating value than biogas for example, but comprise Hydrogen and Carbon monoxide as well as large quantities of inert species, CO₂ and N₂. These fuels need special consideration due to the impact each has on combustor flame speeds and the propensity for “flashback” and the resultant damage to combustion hardware. High Hydrogen content fuels have achieved some success, but require the use of conventional combustion as such fuels tend to “flash back” in lean pre-mix combustors, with consequential hardware damage. Wet injection can be applied to reduce atmospheric pollution. A derivative of this capability is gases produced from coke batteries in the steel making process. Coke Oven Gas, COG, is high hydrogen, but also contains methane and to a lesser extent CO. Conventional, diffusion combustion system is applied but additional gas clean up requirements is essential to prevent a shortening of the hardware life due to the effects of contamination found in such gas fuels.

Natural Gas Liquids and LPG fuels

Less used, but still viable gas turbine fuels include those containing higher hydrocarbon species. These require specific assessment and consideration within both the fuel system and combustor injector.

LPG can be used either in vaporized or liquid form. When vapourised and maintained in gaseous form, the gas should be supplied at elevated temperatures due to the use of the higher hydrocarbons usually associated with LPG, butane and propane. Special injectors will be required to ensure the metered fuel is correctly controlled.

When supplied in liquid form special consideration must be made to the fuel system. LPG has a very low viscosity and special pumps are required to overcome the problem of low lubricity associated with LPG. Control of the fluid is critical to ensure other problems are avoided such as:

- Waxing (fuel temperature too low)
- Exceeding flash point (temperature too high)
- Corrosion (particularly where copper is present)
- Vapour lock due to premature vaporization of liquid

Storage of such fuels needs particular attention. Having a lower viscosity in liquid form and being heavier than air when in gaseous form means special precautions have to be adopted.

Crude Oil as a GT fuel

Viscosity is one of the key parameters used when evaluating liquid fuels for use in industrial gas turbines and generally should be <10cst (most regular diesel fuels <7.5cst @ 40degC). There are cases where neither diesel nor gaseous fuels are available and the only "fuel" is crude oil. This creates challenges that have to be handled through fuel pre-treatment and fuel injection system functionality [11]. Firstly, heating the fuel reduces the viscosity, but noting the limitations:

- First is 100°C, at which water boils off (all liquid fuels contain a small amount of water) causing cavitations in fuel pumps
- Increasing fuel oil supply pressure allows the heating to be extended beyond 100°C, but is limited by the temperature limits within the fuel delivery system
- Further heating can result in fuel cracking and coking in the fuel system and burners depending on the constituents within the crude oil

Crude oils need to be treated in order to meet industrial gas turbine limits on metallic and other contaminants in the fuel. Crude oil often contains high amounts of alkali metals (Na, K) and heavy metals (V, Ni, etc) which if introduced into the combustion system can result in accelerated deposit formation and high temperature corrosion in gas turbine hot gas path components. Major corrosive constituents include Vanadium pentoxide (V₂O₅), sodium sulphate (Na₂SO₄) and aggressive low melting forms in the Na₂SO₄ – V₂O₅ and Na₂O-V₂O₅ systems. Determination of the ash sticking temperature is usually a good feature to use, and should be >900degC if sticking to the blade is to be avoided.

Water and sediment can be removed, or reduced, by filtration and centrifuge separation. This is the same for any liquid fuel, and prevents the formation of corrosive elements and bacterial growth, a pre-cursor to fuel degradation. Removal of the water also reduces the levels of water-soluble contaminants such as the alkali metals sodium and potassium. Vanadium and other heavy metals are oil-soluble though, and can only be treated through chemical dosing so that combustion creates high melting temperature compounds.

Crude oils can also contain more volatile components with a low flash point therefore the need to include explosion proof equipment is often required.

Impact of Sulphur and Metallic Contaminants

Sulphur has various effects on turbine operation. It can be seen as hydrogen sulphide, H₂S, in gaseous fuel or as elemental Sulphur in liquid fuel. How it affects the turbine depends largely on the presence of other metallic compounds and moisture. This has been discussed earlier.

Organic contaminants (tars and asphaltenes) and their impact

Tars tend to be present in small quantities in process gas fuels, such as those from the conversion of coal to coke, resulting in production of Coke Oven Gas, COG. Asphaltenes are small solid particles found in some distillate fuels. These can combine to form a more homogenous mess affecting the filtration system or collect at the bottom of storage tanks forming a sludge like substance.

Water in fuel

Clean dry fuel is essential in achieving best operation of an industrial gas turbine and the presence of contaminants can result in poor turbine operation and increased maintenance. Water in gaseous fuel can be tolerated but the water contained in distillate fuels is most concerning. It can be seen as dissolved, emulsified or free water.

- Dissolved water: chemically dissolved or absorbed into the fuel (e.g. sugar dissolved in hot drinks);
- Emulsified water: tiny droplets of water are suspended in the fuel, making it milky in appearance;
- Free water: falls out of suspension and gathered at the bottom of a storage tank.

It is these latter 2 types, emulsified and free water which are of most concern, resulting in fuel system and engine damage, but also the promotion of bacterial growth.

Wet gas fuels need to be assessed to determine both hydrocarbon and water dew point. Minimum supply temperatures will then be based on the higher of the dew point, subject to the temperature limit of the combustion and fuel system mechanical hardware.

Fuel Storage

Mostly related to liquid fuels, the storage and maintenance of such fuels can be the difference between acceptable turbine operation and one where extensive site maintenance may be required.

Storage of fuel comes under the general heading of fuel handling and best practices. It is necessary to ensure fuel is sourced from good suppliers to approved specifications. Routine monitoring and recording from sampling and analysis of fuels is critical to achieving good turbine operation. Applying best industry practice in receipt, unloading, storage and transfer of liquid fuels is essential to achieving and maintaining fuel to the highest standard and quality. Applying centrifuges, filters and coalescers to storage tanks will help maintain the fluid in the correct condition. Ensuring tank design

meets best industrial standards, including, but not limited to, floating suction take-off to supply gas turbine; bottom drain for sediment and water; allowing sufficient settling time after introducing new supply to tank. ‘Turning’ over the liquid fuel, i.e. using it all on a regular basis, minimizes deterioration and will also help in the long term quality control of the fuel. This is by no means a comprehensive coverage of the use of liquid fuels but attempts to provide the essential aspects that need to be considered.

CONCLUSIONS

The understanding of fuels used in modern high performance, high efficiency gas turbines is a critical step in achieving the goals of high availability and reliability, but at the same ensuring the environmental needs are fully met. The impact of the wide range of fuels used in gas turbine combustion systems, especially those of the low emissions variety, has been considered.

In conclusion, the supply of the right quality fuels can result in the above requirements being met, while the use of fuels outside the advised specifications can result in increased maintenance requirements.

NOMENCLATURE

DLE	Dry Low Emissions
DLN	Dry Low NOx
AFR	Air Fuel Ratio
CO	Carbon Monoxide
CO ₂	Carbon Dioxide
N ₂	Nitrogen
NO _x	Oxides of Nitrogen
O ₂	Oxygen
SO _x	Oxides of Sulphur
UHC	Unburnt Hydrocarbons
H ₂ S	Hydrogen Sulphide
ppmv	parts per million by volume
COG	Coke Oven Gas
LPG	Liquid Petroleum Gas
WI	Wobbe Index
TCWI	Temperature corrected Wobbe Index
LCV(LHV)	Lower Calorific (Heating) Value
HCV(HHV)	Higher Calorific (Heating) Value
Btu	British thermal unit
Ppmvd	parts per million, volume dry

REFERENCES

- 1 R McMillan and D Baker, October 2000
NO_x control in gas turbines - a comparison of approaches
IMEchE Seminar S706 - Meeting Limits on Emissions
- 2 TI Mina et al
A low smoke dual fuel injector with water and steam
injection for industrial gas turbines
Powergen Asia 1997
- 3 B Zeldovich et al
Oxidation of Nitrogen in Combustion
Academy of Sciences, USSR
Moscow-Lenigrad 1947
- 4 H Alkabbie, R McMillan, R Noden, C Morris
Dual fuel dry low emissions (DLE) combustion system for
the ABB Alstom Power 13,4 MW Cyclone gas turbine
ASME Turbo Expo 2000 Munich
- 5 B Igoe and M McGurry
Design, Development and Operational Experience of
ALSTOM’s 13.4MW Cyclone Gas Turbine
ASME TurboExpo 2002
ASME GT2002-30254
- 6 K Syed, E Buchanan
The nature of NO_x formation within an industrial gas
turbine dry low emission combustor
ASME Turbo Expo 2003, Atlanta
ASME GT2003-38211
- 7 TD Newbound and KS Al-Showiman
Tuning your Fuel Gas Delivery System
ASME Turbo Expo 2004, Vienna
ASME GT2004-53298
- 8 Eric M Goodyear
Transport Fuels Technology
ISBN 0 9520186 2 4
Landfall Press, Norwich, UK
- 9 WA15940: 2009
Automotive fuels - Paraffinic diesel from synthesis or
hydrotreatment - Requirements and test methods
- 10 M Welch and P Martin
The Use of Medium Calorific Value gases from Biomass
and Municipal Solid Waste in Industrial Gas Turbine
CEPSI 2002, Fukuoka, Japan
- 11 P Johansson, A Larsson
Heavy Crude Oil as a fuel for the SGT-500 Gas Turbine
World Heavy Oil Congress 2012, Aberdeen

ACKNOWLEDGEMENTS

The compilation of this document would not have been possible without the input and ideas of many people across Siemens Industrial Turbomachinery Ltd whose contribution is recognized. In addition the authors recognize the individual contributions from colleagues in the Combustion Group, Peter Martin, Victoria Sanderson, Ghenna Bulat and Eoghan Buchanan. Finally, the authors would like to thank Siemens Energy for permission to publish this paper.