

Reading real person fiction as digital fiction

Fathallah, Judith

Convergence

DOI:

[10.1177/1354856516688624](https://doi.org/10.1177/1354856516688624)

Published: 01/12/2018

Peer reviewed version

[Cyswllt i'r cyhoeddiad / Link to publication](#)

Dyfyniad o'r fersiwn a gyhoeddwyd / Citation for published version (APA):

Fathallah, J. (2018). Reading real person fiction as digital fiction: An argument for new perspectives. *Convergence*, 24(6), 568-586. <https://doi.org/10.1177/1354856516688624>

Hawliau Cyffredinol / General rights

Copyright and moral rights for the publications made accessible in the public portal are retained by the authors and/or other copyright owners and it is a condition of accessing publications that users recognise and abide by the legal requirements associated with these rights.

- Users may download and print one copy of any publication from the public portal for the purpose of private study or research.
- You may not further distribute the material or use it for any profit-making activity or commercial gain
- You may freely distribute the URL identifying the publication in the public portal ?

Take down policy

If you believe that this document breaches copyright please contact us providing details, and we will remove access to the work immediately and investigate your claim.

Reading real person fiction as digital fiction: An argument for new perspectives

Judith Fathallah

Bangor University, UK

Abstract

'Real person fiction' (RPF) is a subset of fanfiction that has gone largely unnoticed by academics. A handful of articles have argued for the justification of stories about real (living) people as a legitimate and morally sound art form, but only a very few studies have begun to consider RPF as a genre with its own aesthetics and conventions. This article argues that, to understand fanfiction RPF, we need to incorporate tools developed by scholars of digital fiction. Almost all fanfiction is now produced for and on digital platforms, and moreover, the natural fit between RPF specifically and the study of metalepsis, or self-conscious movement between 'levels' of reality and fiction, makes this tool and others imported from the study of digital fiction an illuminating set of lenses through which read it. Along the way, I will incorporate further narrative theory to suggest that we understand appeals to the putative subject of RPF as directed to a 'fictionalized addressee', that is, an addressee who is neither purely fictional nor purely nonfictional, but a construct of mediated activity that demonstrates fandom's participation in the construction of the subcultural celebrity.

Keywords

Convergence, digital cultures, digital fiction, fan cultures, fanfiction, multimodal, narratives, real person fiction

Introduction

Real person fiction (RPF) is a subset of fanfiction that has received scant attention in the literature on fanfiction. This may well be due a shared discomfort between academics and fans concerning the practice of writing fiction about real people (see Thomas, 2014; Zubernis and Larsen, 2012: 146–148), despite the fact that fiction featuring real people as characters is a thriving professional genre. The few academics who have analysed RPF have occasionally compared it to the process of

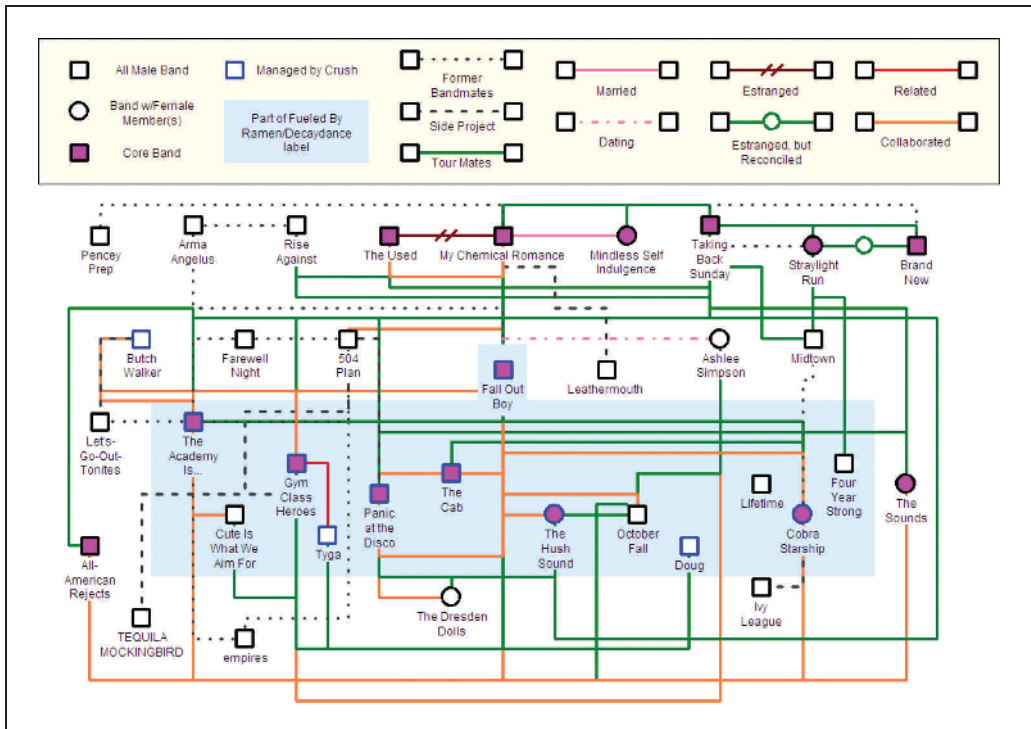

Figure 1. Connections between band bands, by wistfuljane.

fictionalizing people in films (Piper, 2015), but more usually taken a postmodern perspective informed by earlier studies of fanfic, discussing it as a metatextual mode similar to role play, a self-conscious form concerned with the nature of celebrity, identity and performance (Busse, 2005, 2006a, 2006b). I suggest that, given how RPF has flourished with fanfiction’s move to the Internet, it would be useful to import some lenses from the study of digital literature to better understand and appreciate this genre. Of course, the same might apply to all fanfic – primarily now written for, and on, the Internet, and more communication between fan scholars and scholars of digital literature in general would be no bad thing. However, I have chosen to broach this argument with a focus on RPF primarily because, by virtue of its subject matter, it engages in a form of metalepsis, that is, self-conscious movement between actual and possible worlds, a process requiring participation and engagement on the reader’s behalf. As Bell has demonstrated (2014), the hypertextual, multimodal context of digital fiction allows for specific forms of metalepsis, which, I will argue, we see at work in RPF in genre-specific ways.

While hypertextual metalepsis is the overarching tool of investigation here, I will incorporate two further lenses from the field of digital fiction. The RPF I have selected for analysis is, like most digital literature, multimodal. As Rustad (2014) demonstrates, in order to understand multimodal texts, we need to understand the ‘histories’ behind the encounters of different modes, forms and traditions. RPF brings its own cultural history and ‘know-how’ from the practices of fandom and fanfic, which interacts with the affordances of online user interfaces in productive ways. Built on coded platforms, these stories stage encounters between image, sound, text and hypertext. Yet,

they also enact an encounter of fannish, literary, imagistic and technical histories of practice. Metalepsis provides the lens through which we can read many of these encounters. Finally, as Klaiber (2014) argues, digital fiction often takes collaborative forms which superimpose two stories on top of each other, or a 'double plot', as she calls it. Firstly, there is a 'primary plot', that is, the story itself, but we also see frequent evidence of a 'secondary plot', or as I like to call it, a 'meta-story'. This is the collaborative story of the first story being written, the encounters and disagreements between different contributors, interjections from active readers, the constraints and affordances of the site used, and so on. Fandom's communal practice means these meta-stories are much in evidence, and in the case of RPF, an increased level of self-consciousness about the construction of fiction is often present. Indeed, the last of the three stories I will analyse here is *about* the construction of a text, and thus might be said to contain *three* stories: the primary narrative, the story within the story *and* the story *about* the construction of a story. This article makes a first foray into reading RPF as digital fiction, using the tools of metatextual metalepsis, analysis of multiple modes in collision and the self-conscious layering of various levels of story that take place in collaborative fiction.

Background: RPF in academia

The academic study of fanfiction is now well established (Bacon-Smith, 1992; Black, 2008; Fathallah, 2015, 2016; Hellekson and Busse, 2006, 2014; Hotz-Davies et al., 2009; Jenkins, 1992; Stein and Busse, 2009). Jenkins is typically credited with popularizing the field, coining the term 'textual poachers' (1992) to describe and revalue the activity of fans who create their own media by repurposing the affordances of popular culture to resistant needs and desires. While this somewhat idealized perspective may have been necessary at the time, later studies have taken much more sceptical and situated approaches, arguing for both the problems and opportunities of amateur labour in an increasingly convergent media environment (De Kosnik, 2009), or pointing out that while fanfic certainly has resistant potentials and tendencies, the narratives constructed by fans may also be as or more politically regressive than their mainstream sources (Åström, 2010; Scodari, 2003). I have argued elsewhere for a Foucauldian perspective, reading fanfic as an intervention in the discursive formations of popular culture, which may subvert and overturn statements from the corporate media source, but may equally well consolidate and elaborate upon them (Fathallah, forthcoming). Meanwhile, literature and literacy scholars have discussed fanfiction's intersection with postmodern media forms like the pastiche (Jamison, 2013; Polasek, 2012: 49) and its uses for digital literacy training in children (Eleá, 2012; Parrish, 2010).

Overwhelmingly, scholars have focused their attention on fanfiction that makes use of fictional characters. To those of us who are participants in fan culture as well as academia, this cannot but appear as an obvious – even deliberate – oversight. A large and increasing proportion of fanfiction uses versions of real people, living and dead, as its characters. The landing page of the Archive of Our Own (A03), which is currently the most popular repository for fanfiction of all types, boasts extensive catalogues under the subheadings of celebrities and real people and music and bands (probably differentiated because (a) bandom fanfic is a large subset of RPF and (b) the musicians featured in bandom fic are not necessarily celebrities outside of a particular scene). As noted above, fiction about real people is a mainstay of Hollywood and the book industry. But while actor Eddie Redmayne received the 2015 Oscar and BAFTA for best actor for his portrayal of the still-living Stephen Hawking (narrowly beating Benedict Cumberbatch's Alan Turing in

The Imitation Game), both scholars and fans retain a certain reticence and even embarrassment about the creation of fiction about real people. Piper (2015) has addressed this in article comparing the strategies of RPF writers to professional adaptations, biopics and docudramas featuring real people as characters. She observes that ‘the process of presenting a portion of the known public life alongside the fictionalization of a speculated or fantasized private self’ is not fundamentally different from ‘the way biopics re-contextualize the public life of a celebrity through the representation of an imagined private self’ (p. 3.3). While I agree, so far as this goes, I feel that this perspective neglects the specific digital formats of contemporary RPF and its electronic context of dissemination.

McGee, writing in 2005, called RPF the ‘final frontier’ of fanfiction, incorrectly suggesting it as a ‘very recent’ innovation in fandom (*Star Trek* actor RPF can be reliably dated to 1968, when Lorrain and Hunt’s (1989) ‘Visit to a Weird Planet’ appeared in the fanzine *Spockanalia* 3). McGee claimed that it is ‘denounced’ in the fanfiction ‘community’, which hardly seems defensible given the prevalence of RPF today (pp. 172–173). On the other hand, it should be remembered that the landscape of online fandom was quite different in 2006, with more holistic and perhaps closer-knit communities centred on LiveJournal rather than dispersed across Tumblr, the A03 and other sites, so perhaps her arguments have simply dated. She argues that fanfiction is (or perhaps, was) a generally dialogic practice which RPF offends, treating its subjects ‘monologically’, as means and not human ends in themselves. However, she then goes on to explore how RPF writers defend their practice, comparing celebrities to the mythological function of gods and heroes in previous ages (p. 173) and contrasting the celebrity persona, which is what fanfic actually utilizes, to the human person sharing that name with which it has little to do (p. 175). RPF disclaimers often make this point in explicit terms, claiming *not* to deal with real people but their mediated representations only. Thus, RPF is conceived as a form of postmodern fiction that is both explicitly concerned with facets of identity and playfully manipulative of them. Busse (2006a, 2006b) takes up this theme, arguing RPF on LiveJournal demonstrates sophisticated intertextual play with identity and authenticity, both in terms of the topics addressed by stories and the role play and performance fan writers engage with, performing an online identity for themselves and each other. She argues that RPF is best understood as a kind of role play, akin to avatar games, an extension of the identity play with which we engage in all kinds of online encounter.

Thomas, writing in 2014, addresses real person slash (RPS). A very popular form of RPF, RPS pairs real people in fictional same sex relationships. The term ‘slash’ has been imported from general media fandom and dates to the homophobic climate of the 1960s, when relationships were denoted in story metadata through a slash mark between names and initials, decodable only to those in the know. While her statement that RPS is still ‘highly controversial and contentious’ (p. 171) seems questionable for 2014, she is nevertheless right to note that it remains banned on Fanfiction.net and that many fans attempt to distance themselves from it. However, as Thomas argues, there is really no obvious barrier between story forms of RPS and other forms of celebrity engagement that blend frontstage performance with a mediated representation of backstage life, such as Instagram and Twitter. This, after all, is what RPS does: takes a mediated performance of celebrity and creates a narrative about what happens ‘backstage’, albeit in more explicitly fictional terms than gossip sites and other social media. Hagen’s (2015) discussion of ‘stage gay’ in emo/post-punk bands is an excellent illustration of this principle. The core bands that make up the ‘bandom’ category of RPS (loosely: Fall Out Boy, My Chemical Romance, Panic! at the Disco, Cobra Starship, The



Figure 2. Gabriel Saporta (Cobra Starship) and William Beckett (The Academy Is...) hold up signs professing their love for each other. They have also publicly Tweeted each other using sexualized nicknames and refer to their fandom pairing by its portmanteau, 'Gabilliam'.

Academy Is... and an assortment of others signed to Fueled By Ramen and Decaydance) frequently hinted at homosexual relationships between their members, whether by onstage body language, interview sound bites or social media posts. All the above-mentioned bands are connected in various personal and professional ways, so that a typical bandom story features members of at least two or three bands as characters. The connections are best indicated by this flowchart created by fan wistfuljane.

The bands' semi-official explanation of the performance of stage gay was a rejection of homophobia and the hyper-masculinity of the hard-core punk scene that emo reacted against (cf. Hagen, 2014: 52). Fans and academics have both praised and criticized stage gay in political terms, as a progressive response to the aggressive heterosexuality of earlier punk/rock on one hand and a semi-insulting performance that straight men were able to capitalize on without jeopardizing their careers on the other (Busse, 2006b: 211; Hagen, 2014). Bandom bands were and are highly aware of RPS, to the point of discussing it in interviews to and playing up to common pairings for the entertainment of writers (see Figure 2 below).

It is clear then, that so far as bandom goes, RPS is far from a secretive or shameful sub-facet of fandom, but an ongoing part of a vast, postmodern, multi-authored and polymorphously queer text deconstructing performance, identity, sexuality and the alternative music scene – band members themselves being among the contributing authors. Gabriel Saporta, former frontman of Cobra Starship, has gone so far as to contribute his own fic pairing himself with William Beckett of The Academy Is... in an absurd and comic short story wherein he also murders his one-time mentor Pete Wentz, and somehow becomes President of the United States (Outhier, 2009). I propose that, while bearing this textual/cultural heritage in mind, a better reading of RPF/S would account for its specificity as contemporary digital fiction, a form that both enhances and complicates these postmodern thematic concerns. The next section will introduce some key ideas from the study of digital fiction, notably Bell's analysis of metalepsis, and demonstrate how their application to RPF can result in more nuanced readings.

Digital fiction

According to the Digital Fiction International Network, digital fiction may be defined as fiction:

Written for and read on a computer screen [and] that pursues its verbal, discursive and/or conceptual complexity through the digital medium, and would lose something of its aesthetic and semiotic function if it were removed from that medium. (Bell et al., 2010)

That is to say, it is *born digital*, as opposed to fiction written in and for hard copy formats which has later been *digitalized*. E-books reproduced from hard copies, or documents scanned into PDF format, then, are *digitalized fiction*, while the term ‘digital fiction’ should be reserved for fiction composed on and for electronic screens. The vast majority of fanfiction now falls into this category. It is important to maintain this distinction because hypertext, other codes and the electronic context contribute to the meanings of digital fiction, a process that often increasingly involves the collision of multiple semiotic codes. As Thomas argues, we should not immediately conflate new technologies with multimodality in an automatic or unthinking way (2012: 143), and much fanfic is presented in a straightforward text-on-screen format. Interestingly, Fanfiction.net, the oldest and most traditional of the major fanfic archives online, is the only one whose coding does not support embedded imagery, or audio and video clips, and the only one banning RPF. This supports my argument that RPF invites multimodality as the ‘source text’ of celebrity persona spans such a variety of media and is so easily obtainable and editable online. Other theorists have connected digital fiction to postmodern literary thought – as exemplifying Barthes’s “‘writerly” text’, that is, the open, polysemic text which enlists the reader as an active participant; or as Deleuze and Guattari’s ‘rhizome’ – the text whose ‘branching structure’ is realized in the networked affordances of hypertext (Bell et al., 2014: 5). Delany and Landow famously described hypertext as ‘an almost embarrassingly literal reification or actualization’ (1991: 10) of postmodern literary theory. Once again, we observe these structures of composition and practices of reading in abundance on LiveJournal, where RPF has flourished, and to a far lesser degree on Fanfiction.net, whose plain white format and ‘clean’ presentation imitate the printed text at the level of story engagement.

Early works of digital fiction were primarily dependent upon hypertext for both its technological and semiotic affordances, but as Bell et al. go on to argue:

a second generation of digital fiction [...] has emerged, which contains more visual and auditory attributes. From an analytical point of view, while early digital fiction can be said to challenge established concepts such as authors, readers, and literature, more recent digital fiction also investigates the borders between different modalities and art forms, such as the borders between literature, music, graphics, and photography. (2014: 9)

I want to suggest that in reading RPF as digital fiction, the histories and practices of fan culture can be understood as one such modality, while the affordances and growing body of digital fiction functions as another. As we will see, this collision has resulted in some fascinatingly self-aware work around convergent media forms and the production of fiction.

One specific analytical tool I want to draw on is hypertextual metalepsis, as explored by Bell (2014). As Bell explains, ‘metalepsis was originally defined by the narrative theorist Genette as any intrusion by the extradiegetic narrator or narratee into the diegetic universe (or by the diegetic characters into a metadiegetic universe, etc.), or the inverse’ (1980 [1972]: 234–235).

Hypertext, as Bell goes on to explore, is a technologically coded form of the metaleptic jump – so for instance, a fictional story set in a real-world location may contain hyperlinked text to a real-

world panoramic view of that location, or even a live-stream. The reader actively follows this link from a level of fictional engagement to a real-world one, and at the same time, Bell discerns two types of metalepsis. In the first type, ‘the narrator (or a character) jumps to a lower diegetic level’ (2014: 23), for example, when the writer appears as a character in his own or another person’s story. In a sense, all RPF involves this type of metalepsis, as real people act as characters in the fictional story, and authors tend to flag this up in a playful, self-conscious way. In the second type of metalepsis, a ‘fictional character jumps to a higher narrative level’ (p. 23). While this is rarer in RPF, we do find examples in author’s notes where writers appeal to the subjects of their fiction, usually asking them not to read the story. Given band members’ active involvement with LiveJournal, and even a couple of cases in which they have commented on stories in which they appear as characters (Fanlore, 2015a), this may be seen as a simple safeguarding move to spare the writers’ embarrassment.

Yet, it is not quite the ‘character’ being appealed to here. The character would have no need to be protected from the contents of the story (if the character was capable of comprehension, he or she would already know it). We might call it the character’s real-world ‘counterpart’ (Bell, 2014) – and yet, it is more than this. It is also an appeal to a communally created, multimediated *understanding* of a character/persona, invoking their communally understood/created traits. For example, one fairly common injunction of this sort is ‘Back button, Pete’. To the uninitiated, this is nonsensical. To those in the know, it is clearly addressed to Fall Out Boy bassist and lyricist Pete Wentz, a prolific blogger who is notorious for oversharing online and demonstrates a keen understanding of, and involvement with, LiveJournal fandom. The direct address appeals to his irreverent, endearing, curious, trouble-seeking persona and utterly informal relationship with fandom. The properties of this persona are a textual effect created partly through Wentz’s own blogs and social media presence, partly through the contributions of fandom. We can best understand this kind of address as what Ryan calls ‘ontological metalepsis’, which ‘opens a passage between levels’ of reality, and thus ‘result(s) in their interpenetration, or mutual contamination’ (2006: 207). I would suggest, however, that we replace the metaphor of contamination between ‘fiction’ and ‘reality’, or indeed possible realities, with one of constitution or construction. To use contamination in this case would suggest that a person’s social media presence is or should be somehow ‘separate’ from their ‘real’ self, rather than a matter of mutual construction and exchange between the online and offline spheres.

Turk (2011) has argued that in a sense, all fanwork is metaleptic by virtue of its operation across multiple worlds or narrative levels. Discussing fiction based on other fiction, she claims that fanwork is distinct from other kinds of metalepsis because rather than drawing attention to the *difference* between ontological levels

the premise of most fan work is that the fictional world of the story or vid *is* the same as the fictional world of the original text, or rather the fan author’s interpretation of that world; part of the pleasure of the text comes from treating these fictional worlds as contiguous or overlapping. (2011: 89)

While her argument might hold for fanwork sourced on fictional worlds, as we can see, the situation of RPF is quite different. At the textual level, authors *separate* their work from the level of ontology at which band members construct their media presence. However, band RPF’s by platform means that at the technological level, all the texts operate together on that very level simultaneously. Before we go on to the close analysis, I will briefly introduce two more tools from work on digital fiction. Punday (2014) argues that, while previous theorists have primarily

considered the instability of hypertext to be its defining feature, we should also consider what she calls 'texture', a property largely constituted by the user interface. Texture, in Punday's argument, sets the basic rules of expectation, as the user navigates an environment that tells her what kind of text s/he is facing. So, in a narrative game, the perspective might be an immersive one that situates the user as the point of view character within a fictional world. If she is able to collect objects, the area of the screen on which she stores them breaks the diegesis, but she accepts this because she has internalized the rules of this sort of game. The user interface functions to induct the user into the space of game or fiction. There is, in digital fiction, a category of game in which the overlap between playing and reading is significant. Although the texts we'll be addressing are more traditional and less graphic-based than these story games, the user interface of the archive and/or journal still provides a crucial texture, in Punday's terms, that guides the reader's expectations.

Finally, Klaiber (2014) argues that in digital fiction, the process of the story's creation is more evident and self-conscious than in traditional forms. These story spaces are always collaborative (except perhaps in a scenario where a single user codes his own interface and single-handedly authors a unidirectional story onto it that disallows comments or reader interaction, but it would be questionable how far such a hypothetical text should be treated as digital fiction in the first place). There are thus two layers of plot at work simultaneously in collaborative digital fiction: the 'top' plot, at the diegetic level of the fiction, and the 'sub' plot, the story of the creation of the story, which is played out through comments, interaction with users, author's notes, and in some multi-authored stories an explicit back and forth of narrative control at difference places in the story. Co-creators may take many roles, such as reviewers, editors, creators, convenors or collaborators (Klaiber, 2014: 127). In the context of fandom, I would add 'prompter' or 'instigator', as many fan communities run challenges and exchanges wherein stories are written in response to requests of variable specificity. Quite often, the top plot will adhere to conventional ideas of aesthetic unity and coherence, while the under plot is more incoherent and open-ended, though each can spill into the other. Fandom offers multiple examples of this, including stories that have been left unfinished due to arguments with readers, and stories that have changed direction through conversation.

As a first exercise in reading RPF as digital fiction, then, I now turn to three specific works of bandom RPF: one from LiveJournal and two from the A03. I have selected them on the basis of (a) my own familiarity with the communally authored personas of their characters and (b) their use of multimedia in a digital context.

Analysis

Author Kisforkurama's *Pete Wentz vs The World* (2011) is a densely intertextual and multimodal work, composed for the annual Bandom Big Bang: a fandom challenge wherein authors sign up produce 10,000 or 20,000 words of digital fiction which are then set to music and illustrated. As the title suggests, the primary character is Fall Out Boy's Pete Wentz, while the plot is adapted from the 2010 film, *Scott Pilgrim vs. The World*. A large amount of texture is condensed, then, just in this title: We already know through the multiple-authored fan text what sort of character the protagonist is: a reckless and somewhat hapless musician who is prone to get into trouble, but is ultimately the romantic type and fiercely loyal to his friends. We know what the characters look like. We also know, in general terms, what the plot is about: Like Scott Pilgrim, Pete must defeat the members of a 'league of evil exes', in order to win the heart and loyalty of his true love. Immediately then, we are confronted with a metaleptic split: While the characters in this story are people who exist in the real world, the story takes place in an explicitly fictional one. The



Figure 3. Graphic by Kisforkurama.

doubly exophoric referencing continues in the subtitle: ‘This ain’t a date, it’s a goddam death match!’. The ‘death match’ in place of a ‘date’ is of course what the fictional Scott Pilgrim must confront in the eponymous film, yet the exclamation is an adapted refrain from a real-world song by Fall Out Boy (‘This ain’t a scene it’s a goddam arms race’). The real-world and fictional-world resources are indiscriminately mixed, producing the mutual constitution effect described above. The conventions of bandom fic, which are extrapolated from the presentations of real-world friendships and relationships, provide the code by which the bandom characters are slotted into roles from *Scott Pilgrim*. Pete’s ultimate love interest is Michael ‘Mikey’ Way, the bassist from My Chemical Romance, with whom he is certainly close friends in real life and may or may not have been in a sexual relationship with during the summer of 2005. Pete/Mikey is thus a favoured bandom pairing, informed by a readily googleable series of suggestive photographs and poetry from Wentz’s own LiveJournal. The metaleptic mutual construction between fiction and reality continues, and the hypertextual codes of presentation enact this. The story, after all, appears on LiveJournal, every page peppered with hyperlinks taking one deeper into the LiveJournal network, where Wentz’s own real-world journal, and poetically vague account of what may or may not have been a relationship with the real Mikey Way, actually does exist.

The multimodal affordances of html allow this fic to adapt *Scott Pilgrim*’s citation of video game tropes to a story format. The chapters are divided by battles or encounters with evil exes, linked numerically from the masterpost. Clicking on ‘1’ leads the reader to a reproduction of the logo, followed by a graphic asking ‘Ready . . . ?’ before changing to ‘Loading . . . Game Start!’ (see Figure 3).

Similarly, the hyperlink to the next chapter, or level, is a graphic in the same font asking ‘Save and continue?’ while ‘Save and go back’ takes the reader back to the masterpost. Incorporating the



Figure 4. Graphic by Kisforkurama.

language and semiotics of a video game, which is enabled by the relatively flexible codes of LiveJournal, not only continues the intertextual engagement with *Scott Pilgrim* but allows for a certain flexibility with regard to the conventions of *bandom fic*. ‘Character death’ in RPF is a delicate subject. Some authors and readers express hesitation over the fictional killing of real people (Gabe Saporta’s public example notwithstanding), but according to the structure of the video game and its narrative, enemies must be defeated before the character can ‘level up’. In this story, defeated antagonists burst into showers of gold coins, and the following image is inserted (albeit with appropriate variations of names and points earned).

Similarly, each match is introduced as a ‘level’ with an appropriate image. This provision of texture, in Punday’s terms, allows the reader to understand that these ‘deaths’ are non-serious and should be understood at the level of play and gaming.

We can thus see how the analytical insights regarding texture and especially *metalepsis* inform an understanding of this work as digital fiction. Being part of a challenge and hosted on a moderated community, where the moderator takes *Klaiber*’s role as ‘convenor’ of the collection, we can also understand it as a work of multiple authorship. In keeping with the rules of the *Big Bang* challenges, it has been beta read (edited before publication) by another member of the fan community. All *Big Bang* fics are open to reviews in which the primary author often discusses the work with her readers, but given that the rules dictate each work be finished and edited before posting, in keeping with more traditional aesthetic standards, readers play a less active role here than in fics posted by instalment. Digital fiction is sometimes understood as what *Aarseth* (1997) called ‘ergodic literature’, in which the reader must put forth ‘non-trivial effort’ to ‘traverse the text’ (p. 1). At first glance, it appears that the reader can exhaust the affordances of the story merely by clicking links, and perhaps leaving a comment for the author. However, the instability of online content and the legal/economic status of digital works making use of other media has complicated the situation. The story’s playlist, which another author has contributed to the fic, was formerly available as a collated .zip file from the hosting site *Mediafire* but has been removed. This often happens when legal owners file copyright claims against hosting sites. However, the songs listed in the contributor’s journal, which is linked from the masterpost, are all available on *YouTube* and/or *Spotify* for free. Thus, to get the full aesthetic experience of the story, the reader is required to make the ‘non-trivial’ effort of a treasure hunt.

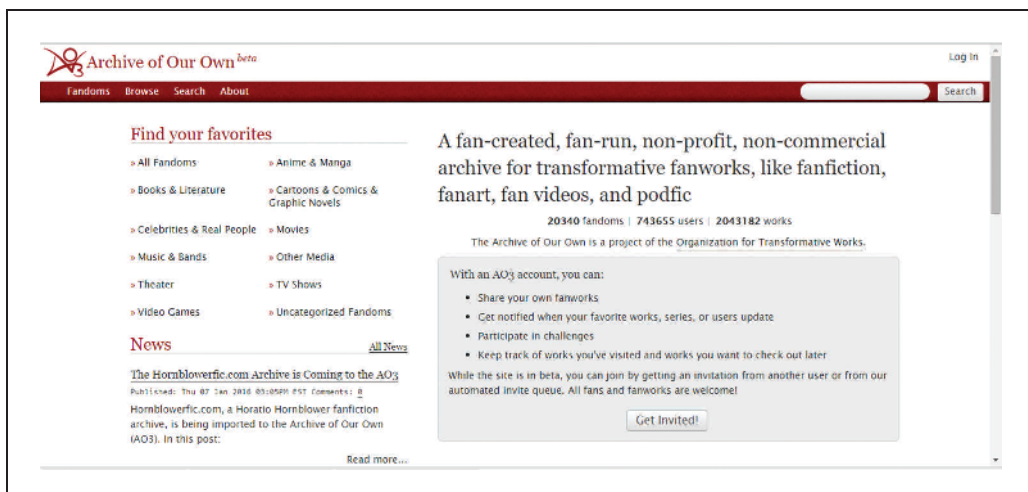

Figure 5. A03 landing page.

Pete Wentz vs the World was posted in 2011, and since then, LiveJournal has been superseded as the primary repository of RP F and fanfic in general. The multimedia works I will now turn to are both hosted on the A03. An archive, particularly one with a possessive literary reference in its name, may be associated with a more traditional stability and preservation of text. Indeed, the primary reason the repository was founded by fans and academics was to make a space where fic could be preserved and not deleted at the whim of censors and server owners (as happened in the event that has come to be known as the Great LiveJournal Strikethrough of 2007; see Fanlore, 2015b). The A03 servers are owned by the Organization for Transformative Works, a project founded by fans and academics in order to ‘serve the interests of fans by providing access to and preserving the history of fanworks and fan culture in its myriad forms’ (OTW, n.d.). The organization’s projects include legal advocacy and awareness raising, and its mission statement is to work for ‘a future in which all fanworks are recognized as legal and transformative, and accepted as legitimate creative activity’ (ibid). While the centralization, organization and preservation of fanfic that is the archive’s remit has generally been a great success, not all fans are happy with its work. In the locked, ephemeral spaces which were the province of early online fandom, some complained that its organizers were presumptuous in their attempts to represent or speak for fandom, and that bringing fanwork to the attention of media producers was a mistake. Nonetheless, A03 remains the primary repository for fanwork as of late 2016, probably because of its ease of navigation, secure hosting of multimedia file types and an excellent user-friendly interface. Most fic archived on LJ and elsewhere has been or is being imported to it.

In some ways, A03 asks for less user effort at the level of reading the story than LiveJournal but more at the level of navigating the archive. As tagging on LJ is sporadic and unregulated, readers frequently locate fic through masterlists or links at recommendation communities. A03 employs volunteer ‘tag wranglers’ to translate author-generated tags into universal categories, so that finding a story becomes an active processing of filtering and ordering on behalf of the user, something I have often experienced as a pleasurable sort of game, or hunt. For example, the front page of A03 appears as in Figure 5.

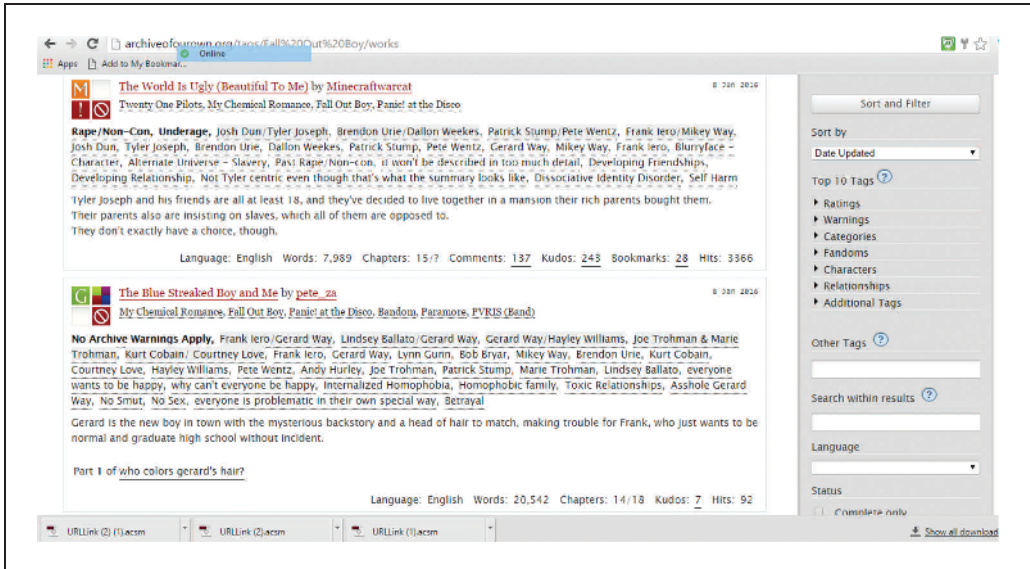

Figure 6. Search results on AO3 with filter pane. Scrolling displays more results.

Clicking the link to ‘music and bands’ brings one to the category listing for different bands and musicians, alphabetically ordered with quick links at the top to different letters. One selects the subcategory of choice and is then presented with a rolling entry of the most recent fics in the category, plus the option to sort and filter via the kinds of category shown in Figure 6:

Expanding the tag menu presents the user with the ten most popular entries for that category, while the drop-down menu for ‘sort’ allows her to arrange the results by update date, word count, number of comments, number of kudos (a virtual currency akin to upvotes or likes) or number of hits. *Selecting* a story, then, is a highly interactive experience in which the user partially constructs her *own* texture, selecting for herself a story to meet her personalized expectations or requirements. Most of the stories themselves, however, are presented in a fairly traditional text-on-page format which, if not for the context of their presentation, might appear more like digitized literature than digital. For the purposes of this analysis, however, I have selected two random fics which do make use of embedded media, and given that in total the archive currently hosts well over two million works, there is still a great deal of fiction here for which these tools are readily appropriate.

Supergrover24’s *A Movie Script Ending* is a pan-bandom fic featuring members of Panic at the Disco, Death Cab For Cutie and The Academy Is... This story is imported from a LiveJournal challenge and linked back to it through a series of opening notes:

Written for mazily in nightmare_xmas. Thanks to ninjab for the location advice, duendeoflorien for hand-holding, and novembersnow for knowing what tense I really wanted to use. Many many thanks to femmequixotic and ze_dragon for organizing and running this holiday exchange. (Supergrover24, 2012)

Editors, supporters, prompter and the conveners of the challenge are explicitly acknowledged here. The ‘story behind the story’, then, as a collaborative and reciprocal process, is indicated



Figure 7. Photo of Andy Mrotek by Tom Carden; as repurposed by Supergrover24.

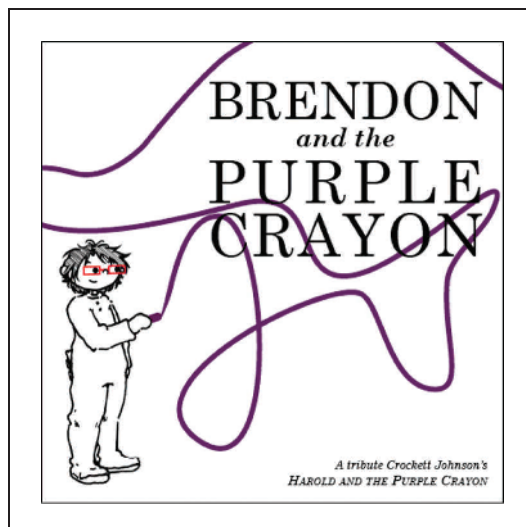

Figure 8. 'Front page' image by Harter, writing as clarityhiding.

through liberal thanks and appears, as Klaiber observed, as a more messy, innovative and gradual process than the polished, aesthetically coherent work presented. Self-conscious metalepsis is the device this fic is built on, for it is entirely comprised of fictional (written) explanations for real (embedded) photographs, which were taken by former The Academy Is . . . guitarist Tom Conrad. The real person Tom Conrad took and posted these images online; his fictional counterpart takes them in the story. The real Tom Conrad thus contributed the material around which his fictional counterpart is constructed, in a metaleptic process made possible by the easy replicability of digital images. Supergrover24 as *author* plays self-consciously with metaleptic levels at every stage of the story, jumping from the actual to the possible even in the length of the disclaimer:

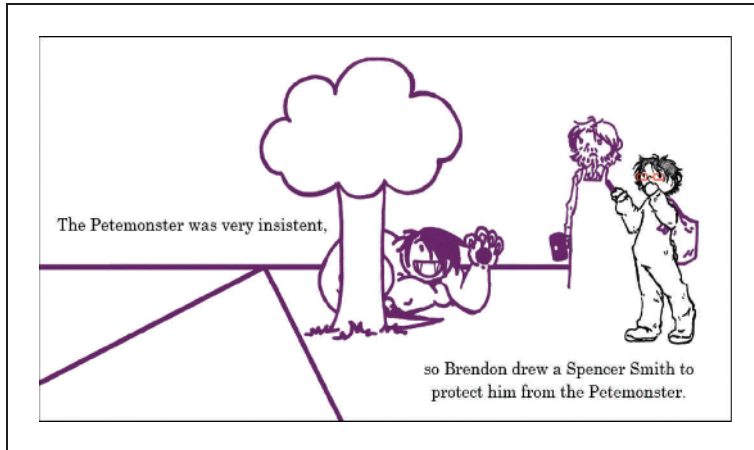

Figure 9. 'Picture book' page by clarityhiding.

All photos property of Tom Conrad. Title from Death Cab For Cutie, Butcher's not-so-guilty pleasure band. Also, no offense meant to anyone. If Jon Walker wasn't where I say he was at a certain point of time, just let it go. It's easier that way. (2012)

The first statement is factual, legalese and refers exophorically and explicitly to the real world. The second jumps to the fannish convention of borrowing and mixing media (Andy 'The Butcher' Mrotek is actually the drummer in both *The Academy Is . . .* and *Death Cab*, but such explicit links are by no means obligatory in the fannish custom). The third and fourth shift avowedly to the realm of fictional possibilities (Jon Walker is a former member of *Panic! At the Disco*, labelmates and frequent touring partners of *The Academy Is . . .*). Notice the use of 'If' as a conjunction though: Of course, this is play, acknowledging the reader's pleasurable investment in the erotic/narrative possibilities of the story, but equally points to the fact that since both the people and the images this story features are taken from the real world, we have no way of knowing with certainty that the story's events did *not* happen in it. *A Movie Script Ending* depicts a series of loosely connected incidents in the bands' lives on the road, developing a narrative introduction to a selection of Carden's photographs. Some of these are framed and formal in composition, others obviously candid:

This time, though, Tom can take pictures all he wants, and he laughs a little, thinking about how pissed he was to have his camera confiscated when he was sixteen. Butcher's adjusting his kit, head cocked, concentrating on the sound coming from the tom, and doesn't notice when the flash goes off.

I bet that'll turn out nice.

'Jonny Walker, what a surprise.' Tom doesn't turn around, but he can't help the grin spreading on his face behind the camera. He tips his head toward Butcher. 'He know about this?' (Supergrover24, 2012)

The narrative disjunction between flowing text, relating a moving a story, and still images, capturing an instant, mirrors and enacts the disjunction between real and possible worlds: from the fictional introduction, to the real-world moment, captured and re-interpreted to the forward progression of the plot.

Also hosted on A03, Harter's *Brendon and the Purple Crayon* (2008, writing as clarityhiding) is a random fic of a different sort. The summary introduces it as 'a picture book consisting of 30+ images within a framing story'. It is another import from LiveJournal, where its page contains a 250-comment discussion between author and readers. On A03, less intertextuality is immediately evident, as the text has just four comments here. The author notes in one that she has

actually ended up binding a copy of this (with some names changed to protect me from any parents who might accidentally out my RPF adventures) and giving it to my mother to use in her 2nd grade classroom as an example of a parody/tribute. (Harter, 2012)

Notably then, this fic has actually taken the opposite trajectory to a piece of analogue fiction that has been digitized, moving from a highly interactive and unstable forum to a more secure repository and finally to a printed hard copy. Although a similar trajectory can be observed with some Twitter fiction, such as Egan's *Black Box* (2012), it is interesting to observe the phenomenon at work in a community that academics have associated with innovative and experimental writing (Busse, 2006a, 2006b; Derecho, 2006; Lackner et al., 2006). This accords with Thomas' observation that we should not posit a simple one-way trajectory from an imagined stable 'print culture' of the past to a multimodal age of screens (2012: 148) but be prepared to conduct more empirical work on the varied transformations and trajectories of particular texts in context.

As the title suggests, this story is an intertextual adaptation of Crockett Johnson's famous children's story. The title in combination with the author's note: 'THIS IS COMPLETE CRACK' indicate the texture. 'Crack' is a fandom term for fic that is self-consciously ridiculous, combining absurdist humour and semi-coherent plots, and often featuring elements of magical realism. In crack fic, characters' behaviour may be at odds with their typical depiction/construction in fandom, and noting this from the outside pre-empts reader complaints on that score. In a requirement for non-trivial reader effort, the author advises that the story 'might be even more amusing (or make more sense) if you're familiar with *Harold and the Purple Crayon*' whose Wikipedia page is linked from the underlined title. Singular authorship is then playfully disavowed, as the author notes 'this is mostly the fault of the plot bunnies [fan term for ideas that seem to come out of nowhere and demand to be written into stories], but Reishin and Brandixcyanide helped spur the bunnies on, so' (Harter, 2012).

As with *Movie Script*, metalepsis and creativity are key themes of *Crayon*, but here in a comic mode. In the source text of *Harold and the Purple Crayon*, 4-year-old Harold has the power to create reality by drawing it with his crayon. In Harter's story, more complex layers are at work. The Brendon referenced in the title is Brendon Urie, frontman of Panic! At the Disco, whose persona is generally constructed as well meaning but highly awkward and somewhat immature. His (former) bandmates feature as other characters. Unlike Harold, Brendon does not have the power to draw things into existence, but to ameliorate his boredom while sick, his bandmate Ryan Ross draws him a picture book. The picture book Ryan draws comprises the embedded images we read. Yet, they also comprise an independent story within a story. It is introduced thus:

'You keep whining about how you're bored, so we're going to do something to fix that,' Ryan explained. He flipped open the book, grabbed a pen, and began to draw.

Inserting the first image at this point both continues the diegesis of conversation between Brendon and Ryan as characters (by demonstrating what Ryan 'draws') and breaks it by

announcing the fiction within the fiction, which then continues as a picture book. In short, this is RPF about RPF. In this picture book, unsurprisingly, the cartoon Brendon *does* have a magic crayon that can alter reality and proceeds to draw a series of adventures featuring his bandmates. For clarity, we'll call this the 'inner' level of the fiction. The picture book contains imagistic humour which depends on the fan's prior knowledge of band history. For instance, the character known only as the 'Petemonster' is identifiable as Pete Wentz due to a characteristic hairstyle (straightened with a side fringe) that Wentz was known for in the early FOB days.

The second joke depending on a mixed-mode format is the insertion of the indefinite article 'a' before (former Panic! drummer) Spencer Smith's name. This apparently explains why he is being drawn as a literal smith of some description. Meanwhile, from the 'outer' level of the fiction, the characters interrupt to comment on their depiction:

'Wait. Why am I holding a hammer? And what's with the silly apron?' Spencer asked, frowning at the picture Ryan was drawing.

Ryan sighed. 'It's not really you. It's someone who kind of vaguely looks like you and has the same name. And he's a smith'. (Harter, 2008)

Thus, through the self-conscious manipulation of metaleptic levels, the author is able to have the characters comment on their own depiction in RPF in general, echoing the earlier academic defence that RPF deals in 'personas' rather than people. In many places, it appears the characters in the outer fiction are imitating the interlocutory role of commenters:

'Pirate Bob,' Ryan said, staring at the picture. 'What is [former My Chemical Romance drummer] Bob Bryar doing in this story?'

'Uh, being an awesome pirate and saving the day?' Jon said, raising his eyebrows. Brendon grinned at him. Bob was pretty awesome, even if he was more a ninja than a pirate.

I'm just saying, I don't see why you needed to put in Bob Bryar. (Harter, 2008)

Thus, we can see that RPF has reached a degree of sophistication, at least in band fic, where it comments ironically on its own construction and tropes. In this case, it is the juxtaposition of mixed modes, and with them, different metaleptic levels that have allowed for these narrative developments.

Conclusion

RPF is, in some ways, simply the latest development in a long-standing tradition of fiction about real people. In other ways, as Busse (2006a, 2006b) has argued, it is a distinctly contemporary and postmodern form, self-consciously aware of its own commentary on identity and reality in the digital era. I have demonstrated that to properly appreciate RPF as a form, we need to view it as a form of specifically digital fiction. Although it has analogue predecessors, its contemporary expression in multimodal, highly textured and collaborative sites means the specific affordances of Web 2.0 contribute to its layers of meaning. Notably, though, we have also observed the beginnings of a trend *away* from such digital affordances: the mass import of fanworks to the relatively stable A03, on one hand, and the preservation of born-digital works in hard copy on the other. Thus, we ought not to view the progression of fanworks as some kind of one-way trajectory, from hard copy zines circulated in private circles to evermore interactive multimodal texts built on increasingly complex code. Rather we need to be alert to the specific contexts, technological and

social, of individual works, and be aware of the specific tools that research in the broader field of fiction can make available.

Acknowledgement

The author thanks Dr Lyle Skains and Professor Astrid Ensslin, whose presentation on contemporary research in digital fiction prompted many of the ideas in this article.

References

- Aarseth E (1997) *Cybertext: Perspectives on Ergodic Literature*. Baltimore: Johns Hopkins University Press.
- Åström B (2010) 'Let's get those Winchesters pregnant': Male pregnancy in *Supernatural* fan fiction. *Transformative Works and Cultures* 4. DOI: 10.3983/twc.2010.0135.
- Bacon-Smith C (1992) *Enterprising Women: Television Fandom and the Creation of Popular Myth*. Philadelphia, PA: University of Pennsylvania Press.
- Bell A (2014) Media-specific metalepsis in 10:01. In: Bell A, Ensslin A, and Rustad H (eds), *Analyzing Digital Fiction*. New York: Routledge, pp. 21–38.
- Bell A, Ensslin A, Pressman J, et al. (2010) A [s]creed for digital fiction. *Electronic Book Review*. Available at: <http://www.electronicbookreview.com/thread/electropoetics/DFINative>
- Bell A, Ensslin A, and Rustad K (2014) Introduction: From theorizing to analyzing digital fiction. In: Bell A, Ensslin A, and Rustad H (eds), *Analyzing Digital Fiction*. New York: Routledge, pp. 3–17.
- Black R (2008) *Adolescents and Online Fanfiction*. New York: Peter Lang.
- Busse K (2005) 'Digital get down': Postmodern boy band slash and the queer female space. In: Malcolm CA and Nyman J (eds), *Eros.usa: Essays on the Culture and Literature of Desire*. Gdansk: Wydawnictwo Uniwersytetu Gdanskiego, pp. 103–125.
- Busse K (2006a) My life is a WIP on my LJ: Slashing the slasher and the reality of celebrity and internet performances. In: Hellekson K and Busse K (eds), *Fan Fiction and Fan Communities in the Age of the Internet*. Jefferson: McFarland, pp. 207–224.
- Busse K (2006b) 'I'm jealous of the fake me': Postmodern subjectivity and identity construction in boy band fan fiction. In: Holmes S and Redmond S (eds), *Framing Celebrity: New Directions in Celebrity Culture*. London: Routledge, pp. 253–267.
- De Kosnik A (2009) Should fan fiction be free? *Cinema Journal* 48(4): 118–124.
- Delany P and Landow GP (1991) *Hypermedia and Literary Studies*. Cambridge: MIT University Press.
- Derecho A (2006) Archontic literature: A definition, a history, and several theories of fanfiction. In: Hellekson K and Busse K (eds), *Fan Fiction and Fan Communities in the Age of the Internet*. Jefferson: McFarland, pp. 61–78.
- Egan J (2012) *Black Box*. *The New Yorker Magazine*, 4–11 June 2012. Originally published on Twitter, May 2012.
- Eleá I (2012) Fanfiction and webnovelas: The digital reading and writing of Brazilian adolescent girls. In: Ross K (ed), *The Handbook of Gender, Sex and Media*. West Sussex: Wiley and Sons, pp. 71–87.
- Fanlore (2015a) Bandom and the fourth wall. Available at: http://fanlore.org/wiki/Bandom_and_the_Fourth_Wall.
- Fanlore (2015b) Strikethrough and Boldthrough. Available at: http://fanlore.org/wiki/Strikethrough_and_Boldthrough.
- Fathallah JM (2015) Won't somebody please think of the children? Or, *South Park* fanfic and the political realm. *Journal of Youth Studies* 18(10): 1309–1325.
- Fathallah JM (2016) Statements and silence: Fanfic paratexts for *ASOIAF/Game of Thrones*. *Continuum: Journal of Media & Cultural Studies* 30(1): 75–88.
- Fathallah JM (forthcoming) *Fanfiction and the Author: How Fanfic Changes Popular Cultural Texts*. Amsterdam: Amsterdam University Press.

- Genette G (1980 [1972]) *Narrative Discourse: An Essay in Method*. Ithaca: Cornell UP.
- Hagen R (2015). 'Bandom ate my face': The collapse of the fourth wall in online fan fiction. *Popular Music and Society* 31(1): 44–58.
- Harter AR, writing as clarityhiding (2008) *Brendon and the Purple Crayon*. A03. Available at: <http://archiveofourown.org/works/232307>
- Hellekson K and Busse K (eds) (2006) *Fan Fiction and Fan Communities in the Age of the Internet*. Jefferson: McFarland.
- Hellekson K and Busse K (2014) *The Fan Fiction Studies Reader*. Iowa: University of Iowa Press
- Hotz-Davies I, Kirchofer A, and Leppänen A (eds) (2009) *Internet Fictions*. Newcastle upon Tyne: Cambridge Scholars.
- Jamison A (2013) *Fic: Why Fanfiction Is Taking Over the World*. Dallas: BenBella.
- Jenkins H (1992) *Textual Poachers: Television Fans and Participatory Culture*. London and New York: Routledge.
- Kisforkurama (2011) *Pete Wentz vs The World*. Available at: <http://kisforkurama.livejournal.com/141600.html>
- Klaiber I (2014) Wreading together: The double plot of collaborative fiction. In: Bell A, Ensslin A, and Rustad H (eds), *Analyzing Digital Fiction*. New York: Routledge, pp. 124–140.
- Lackner E, Lucas BL, and Reid RE (2006) Cunning linguists: The erotics of words/silence/flesh. In: Hellekson K and Busse K (eds), *Fan Fiction and Fan Communities in the Age of the Internet*. Jefferson: McFarland, pp. 189–206.
- Lorrah J and Hunt WF (1989) Visit to a weird planet. *Spockanalia* 3. Scans. Available at: http://fanlore.org/wiki/Visit_to_a_Weird_Planet
- McGee J (2005) 'In the end it's all made up': The ethics of fan fiction and real person fiction. In: Japp PM, Meister M, and Japp DK (eds), *Communication Ethics, Media and Popular Culture*. New York: Peter Lang, pp. 161–180.
- Outhier C (2009) Cobra starship's Gabe Saporta does band fanfic better than the most prolific fangirl. *Phoenix New Times*, 22 October. Available at: <http://www.phoenixnewtimes.com/music/cobra-starships-gabe-saporta-does-band-fan-fiction-better-than-the-most-prolific-fangirl-6431239>
- Parrish J (2010) Encouraging feedback: Responding to fan fiction at different colored pens. In: Urbanski H (ed), *Writing and the Digital Generation: Essays on New Media Rhetoric*. Jefferson: McFarland, pp. 213–225.
- Piper M (2015) Real body, fake person: Recontextualizing celebrity bodies in fandom and film. *Transformative Works and Cultures* 20. Available at: <http://dx.doi.org/10.3983/twc.2015.0664>
- Polasek A D (2012) Winning 'The Grand Game': Sherlock and the fragmentation of fan discourse. In: Stein L and Busse K (eds), *Sherlock and Transmedia Fandom: Essays on the BBC Series*. Jefferson: McFarland, pp. 41–54.
- Punday D (2014) Seeing into the worlds of digital fiction. In: Bell A, Ensslin A, and Rustad H (eds), *Analyzing Digital Fiction*. New York: Routledge, pp. 68–84.
- Rustad HK (2014) (In-)between word, image and sound: Cultural encounter in *Flight Paths*. In: Bell A, Ensslin A, and Rustad H (eds), *Analyzing Digital Fiction*. New York: Routledge, pp. 143–158.
- Ryan ML (2006) *Avatars of Story*. Minneapolis: University of Minneapolis Press.
- Scodari C (2003) Resistance re-examined: Gender, fan practices, and science fiction television. *Popular Communication* 1: 111–130.
- Stein LE and Busse K (2009) Limit play: Fan authorship between source text, intertext, and context. *Popular Communication* 7(4): 192–207.
- Supergrover24 (2012) *A Movie Script Ending*. A03. Available at: <http://archiveofourown.org/works/440091>
- Thomas B (2012) Gains and losses? Writing it all down: Fanfiction and multimodality. In: Page R (ed), *New Perspectives on Narrative and Multimodality*. London: Routledge, pp. 142–154.

- Thomas B (2014) Fans behaving badly? Real person fic and the blurring of the boundaries between the public and the private. In: Thomas B and Round J (eds), *Real Lives, Celebrity Stories: Narratives of Ordinary and Extraordinary People Across Media*. New York: Bloomsbury, pp. 171–185.
- Turk T (2011) Metalepsis in fan vids and fan fiction. In: Kukkonen K and Klimek S (eds), *Metalepsis in Popular Culture*. Berlin: De Gruyter, pp. 83–103.
- Zubernis L and Larsen K (2012). *Fandom at the Crossroads: Celebration, Shame and Fan/Producer Relationships*. Newcastle upon Tyne: Cambridge Scholars.

Author biography

