

**Modelling the March 2012 solar events and their impacts at Voyager 1 in the vicinity of the heliopause**

Intriligator, J.M.; Intriligator, D.S.; Sunl, W.; Miller, W.D.; Dryer, M.; Deehr, C.; Webber, W.R.; Intriligator, J.; Detman, T.M.

Journal of Physics: Conference Series

DOI:

[10.1088/1742-6596/577/1/012013](https://doi.org/10.1088/1742-6596/577/1/012013)

Published: 01/03/2014

Publisher's PDF, also known as Version of record

[Cyswllt i'r cyhoeddiad / Link to publication](#)

Dyfyniad o'r fersiwn a gyhoeddwyd / Citation for published version (APA):

Intriligator, J. M., Intriligator, D. S., Sunl, W., Miller, W. D., Dryer, M., Deehr, C., Webber, W. R., Intriligator, J., & Detman, T. M. (2014). Modelling the March 2012 solar events and their impacts at Voyager 1 in the vicinity of the heliopause. *Journal of Physics: Conference Series*, 577. <https://doi.org/10.1088/1742-6596/577/1/012013>

Hawliau Cyffredinol / General rights

Copyright and moral rights for the publications made accessible in the public portal are retained by the authors and/or other copyright owners and it is a condition of accessing publications that users recognise and abide by the legal requirements associated with these rights.

- Users may download and print one copy of any publication from the public portal for the purpose of private study or research.
- You may not further distribute the material or use it for any profit-making activity or commercial gain
- You may freely distribute the URL identifying the publication in the public portal ?

Take down policy

If you believe that this document breaches copyright please contact us providing details, and we will remove access to the work immediately and investigate your claim.

Modelling the March 2012 solar events and their impacts at Voyager 1 in the vicinity of the heliopause

D S Intriligator¹, W Sun^{1,2}, W D Miller¹, M Dryer¹, C Deehr²,
W R Webber³, J M Intriligator^{1,4}, and T M Detman¹

¹ Carmel Research Center, Santa Monica, CA 90406, USA

² University of Alaska, Fairbanks, AK 99775, USA

³ New Mexico State University, Las Cruces, NM 88003, USA

⁴ Bangor University, Bangor, Wales, LL57 2TT, UK

E-mail: devriei@aol.com

Abstract. Using our three dimensional (3D) time-dependent kinematic HAFSS model we propagate the March 2012 solar events from the Sun to Voyager 1 (V1) to investigate if these solar events could be responsible for the V1 April-May 2013 Plasma Wave Spectrometer (PWS) measurements of enhanced 2-3 kHz signals. These PWS measurements provided the basis for the confirmation that V1 entered the interstellar medium (ISM). These enhanced PWS signals also were associated with significantly increased plasma densities consistent with expectations for the ISM. The origin of these enhanced plasma densities was attributed to the April-May 2013 arrival at the heliopause of the disturbances associated with the March 2012 solar events. Using HAFSS we propagate from the Sun the March 2012 solar wind ambient background and the solar wind impulsive events for comparisons with in-situ spacecraft measurements at Earth, V1 (at 34 degrees North), and Voyager 2 (at 30 degrees South). The in-situ measurements of the March 2012 events were obtained over a wide range in radial distance, longitude, and latitude. This emphasizes the importance of using a 3D time-dependent model that originates at the Sun. From our analyses we conclude that the March 2012 solar events could have been responsible for the April-May 2013 V1 enhanced plasma wave signals and their associated increased plasma densities measured by the PWS indicating V1 was in the ISM.

1. Introduction

The Voyager 1 (V1) energetic particle measurements from April-August 2012 provided information [1-3] that the V1 spacecraft (s/c) may have been near the heliopause (HP). The LECP [1] and CRS [4,2] energetic particle measurements apparently even indicated that on August 25, 2012 V1 was crossed by the HP [4]. However, the V1 magnetometer data [3] appeared to be not as definitive, since the magnetic field magnitude increased as expected for a crossing of the HP, but the expected accompanying change in the magnetic field direction was not seen. The V1 Plasma Spectrometer (PLS) had not been able to make plasma measurements since 1980, so the expected increase in plasma density across the HP and into the ISM could not directly be observed. Subsequently [5] found evidence in the Plasma Wave Spectrometer (PWS) measurements of enhanced signals in the 2-3 kHz range consistent with the substantial increase in plasma density expected if V1 entered the ISM. [5] suggested that these enhanced PWS plasma wave signals were associated with the V1 PWS detecting the impacts of the March 2012 solar events on the HP.

The purpose of this present paper is to investigate whether solar events in March 2012 gave rise to interplanetary plasma disturbances (e.g., shocks, merged interaction regions (MIRs), etc.) that could



have been responsible for the observed enhanced signals in the 2-3 kHz PWS measurements. We present our initial results from 3D time-dependent kinematic simulations of the March 2012 solar events by the HAFSS (Hakamada-Akasofu-Fry Source Surface) method, which simulates the slowly varying solar wind background starting at the Sun and the impulsive time-dependent solar wind events associated with solar activity (e.g., coronal mass ejections (CMEs).

In the HAFSS model perturbations are imposed on the boundary conditions at the Sun to simulate solar activity. The tuning of both the background solar wind state and the impulsive solar wind from solar events is iterative, but the background model tuning only needs to be done once for the period of interest. In previous analyses we developed methods that make shock simulation inputs converge very quickly. Our tuning uses strictly quantitative verification of model results against spacecraft data. Only quantitative testing of such models in a 3D time-dependent context against spacecraft data can both further validate and improve the models. See [6] for a more detailed description of the HAFSS model.

In March 2012 NOAA solar Active Region (AR) 1429 emitted a series of disturbances and CMEs. Table 1 summarizes the characteristics of this March 2012 solar activity as obtained from the NOAA Space Weather Prediction Center daily Report of Solar Geophysical Activity. In Table 1 [7] the first column is the number of the event; the second, the four-digit year; the third, the four-digit month and day; the next column is the two-digit hour and the two-digit minutes of the event; the next two columns are the solar latitude and longitude of the event; VS is the shock speed (in km/s) of the event's CME, shock, etc. We have two columns labelled VS. The first VS column lists the "tuned" shock speed values that we estimated from comparisons between the initial HAFSS simulations and the ACE data. The column labelled (VS) - with parentheses - lists the original SWPC/USAF estimates. The difference between these VS and (VS) values is indicative that at times there is a large uncertainty in the reported SWPC/USAF (VS) estimates. The TAU value (in hours and minutes) is the assumed duration of the piston driving time of the coronal shocks above the flare site. Thereafter the shape of the shock is determined by the HAFSS simulation and not by an assumed cone angle. VSW is the ambient solar wind speed (in km/s); OPT is the optical magnitude of the event; and XRAY is the x-ray magnitude of the event.

Table 1. March 2012 Solar Events and HAFSS Model Inputs

NNNN	YYYY	MMDD	HHMM	LAT	LON	VS	(VS)	TAU	VSW	OPT	XRAY
0001	2012	0305	0002	N17	E029	800	(2273)	0100	750	XXX	X5.4
0002	2012	0305	0409	N17	E041	840	(1340)	0100	750	2B	XXX
0003	2012	0307	0024	N17	E027	1450	(2293)	0015	750	XXX	XXX
0004	2012	0309	0343	N17	W003	350	(1285)	0300	750	XXX	XXX
0005	2012	0310	1200	N17	W024	1110	(1037)	0100	750	XXX	XXX

2. HAFSS Comparisons with OMNI data at Earth at 1 AU

The first comparisons of the HAFSS simulations with spacecraft data for the March 2012 events are shown in Figure 1. It shows comparisons at 1 AU between the in-situ OMNI spacecraft data (the black line) in the vicinity of Earth and two types of HAFSS model results. The blue line shows the modelling results at Earth using only the background (ambient) solar wind inputs. The red line indicates the results of HAFSS simulations that combine the background solar wind inputs and the impulsive solar wind inputs from the solar events in Table 1. Solar wind speed (upper panel) and density (lower panel) are shown in Figure 1.

The solar wind speed comparisons indicate relatively good agreements between the full HAFSS modelling results (the red line) and the in-situ OMNI measured speeds (the black line). The HAFSS simulations show good agreement with the observed OMNI arrival times of all three events and the speed magnitudes of the first and third events, but HAFSS overestimates the speed increase of the second event. Overall, the speed profile from the HAFSS results is quite similar to the OMNI speed

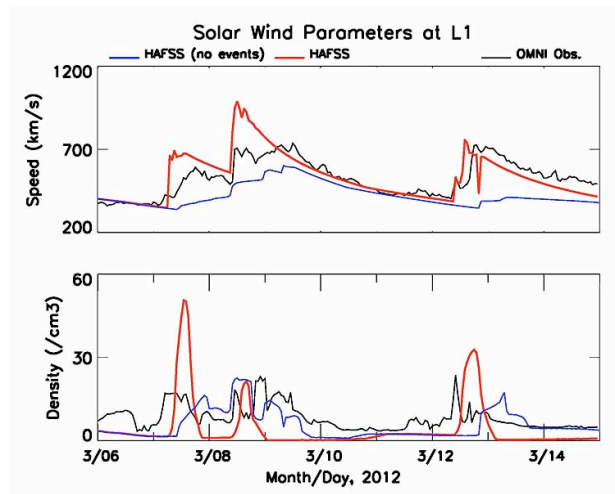

Figure 1. Comparison of HAFSS 3D time-dependent simulation time series results with L1 OMNI observations near Earth (see text). The red line indicates the HAFSS simulation using as inputs the background solar wind and the solar wind from the impulsive solar events (Table 1). The blue line shows the HAFSS results at Earth using only the background (ambient) solar wind inputs. The OMNI data are shown by the black line.

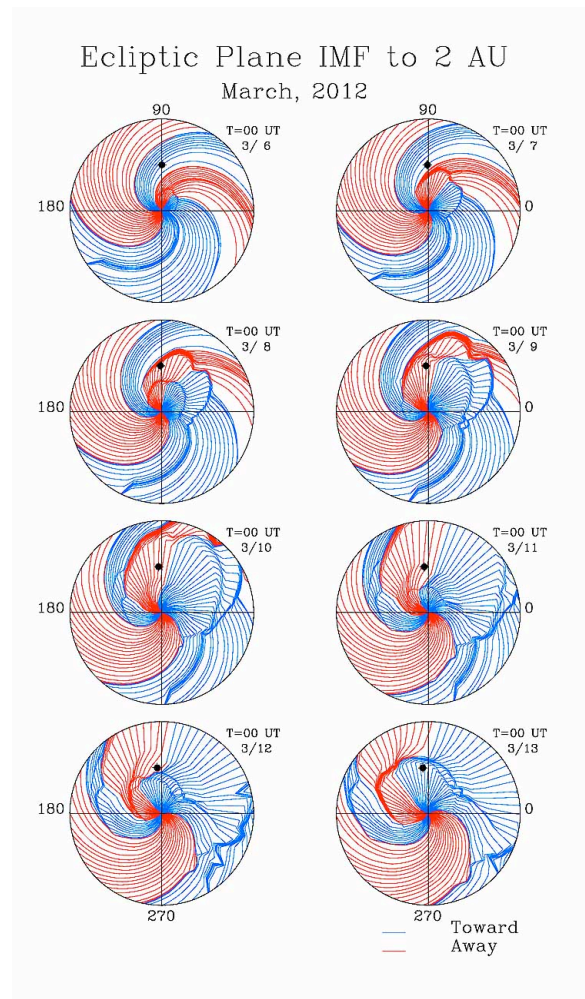

Figure 2. HAFSS ecliptic plane simulation plots of the IMF from the Sun to 2 AU.

data (black line). The plasma density comparisons show fairly good agreements for the arrival times of the events, but HAFSS overestimates the magnitude of the density increase for the first event.

In Figure 2 we show the HAFSS simulation of a series of plots indicating the results of HAFSS calculations of the changing interplanetary magnetic field (IMF) configuration in the ecliptic plane out to 2 AU as a function of time between March 6 and March 13, 2012. The black dot indicates the location of Earth. The blue lines show the configuration of the IMF having an orientation “toward” the Sun. The red lines show the “away” orientation of the IMF. The IMF changes in the time sequence of the figures clearly show the expansion of the March 2012 disturbances as they propagate from the Sun to 2 AU.

3. HAFSS Comparisons at V2 at 30 degrees South

Figure 3 is a plot of the HAFSS simulated IMF in the ecliptic plane out to 140 AU as of April 1, 2013. Figure 3 thus estimates the results for more than one year, from March 2012 to April 1, 2013, of the propagation of the disturbances. The format in Figure 3 is similar to the individual IMF plots in Figure 2. From Figure 3 it is evident that the magnetic field effects of these disturbances primarily propagate

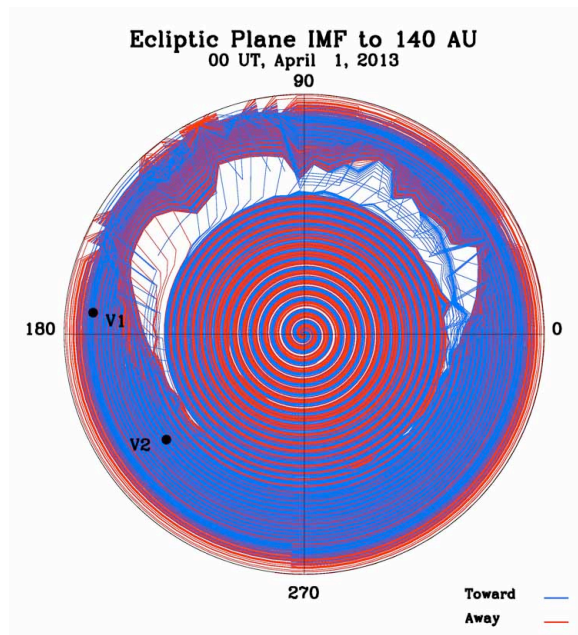

Figure 3. HAFSS ecliptic plane plot of the magnetic field from the Sun to 140 AU. The black dots indicate the locations of V1 at 174 degrees and 123 AU and of V2 at 217 degrees and 101 AU.

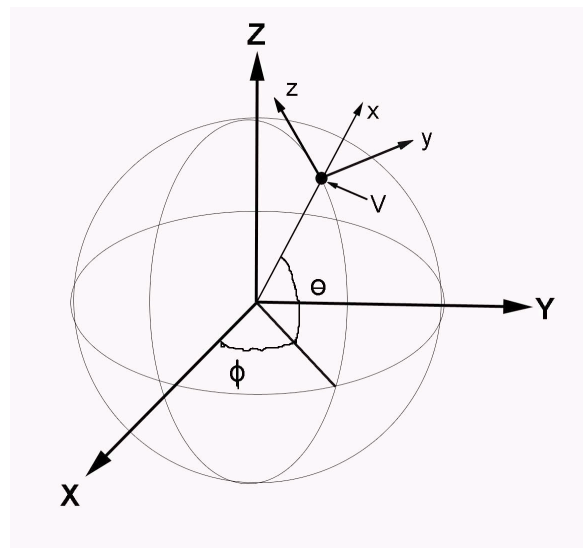

Figure 4. Coordinate transformation, where
 $x = X \cos\Theta \cos\Phi + Y \cos\Theta \sin\Phi + Z \sin\Theta$
 $y = -X \sin\Phi + Y \cos\Phi$
 $z = -X \sin\Theta \cos\Phi - Y \sin\Theta \sin\Phi + Z \cos\Theta$

in the upper hemisphere (0-90-180 degrees). Thus, there is a large asymmetry in longitude of the IMF disturbance as it propagates to greater radial distances from the Sun.

Although Figure 3 shows the IMF in the ecliptic plane, Voyagers 2 and 1 are not located in that plane. Voyager 2 is located at 30 degrees South and Voyager 1 is located at 34 degrees North. In order to more accurately determine the effects of the March 2012 events at each of these spacecraft we employed a coordinate transformation and applied it to each of these spacecraft. Figure 4 shows the coordinate transformation. In the HAFSS code all calculations of speed, density, and magnetic field are in Heliographic Equatorial (HEQ) coordinates so that longitude in the EC plots or other tilted plane plots should be in HEQ coordinates. In Figure 4 XYZ is in the HEQ coordinate system.

A new coordinate is designed as the xyz system at point V (location of Voyager). The tilt angle of the xy plane to the XY plane is the Θ angle. The difference of longitude between XYZ and xyz system is the angle Φ .

Figure 5 is similar in format to Figure 3 and shows the HAFSS calculated plasma density in the ecliptic plane out to 140 AU as of April 1, 2013, due to the effects of the March 2012 solar events. It is evident that there is a strong similarity between the HAFSS simulated propagation of the magnetic field in Figure 3 and the HAFSS simulated propagation of the plasma density in Figure 5.

Figure 6 is similar in format to Figure 3 and shows the HAFSS calculated plasma density on April 1, 2013 out to 140 AU in the V2 plane, which is tilted to 30 degrees South, and is in an xyz coordinate system in which the 0 axis is the radius from the Sun to V2; likewise, Figure 7 shows on April 1, 2013, the HAFSS estimated plasma density to 140 AU in the meridian plane at the longitude of V2 at 217 degrees. These figures thus improve on Figures 3 and 5 by estimating how the March 2012 disturbances propagated from the Sun in planes containing the actual location of V2.

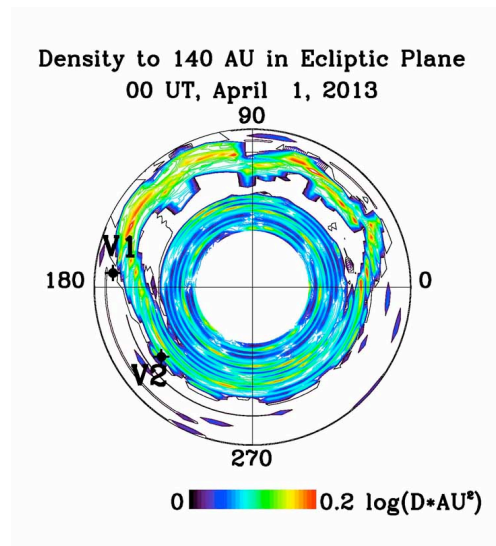

Figure 5. HAFSS ecliptic plane simulation plot of the plasma density from the Sun to 140 AU on April 1, 2013.

Figure 8 is similar to Figure 1 and compares the time series of the HAFSS plasma results (blue and red lines) with the Voyager 2 PLS plasma observations (black dots). The comparisons are shown for the plasma speed (upper panel) and plasma density (lower panel). In these plots the longer-term trends are genuine predictions. The shorter, nearly periodic fluctuations are artefacts of the current state of the calculation method. The measured plasma speeds are substantially less than the HAFSS modelled

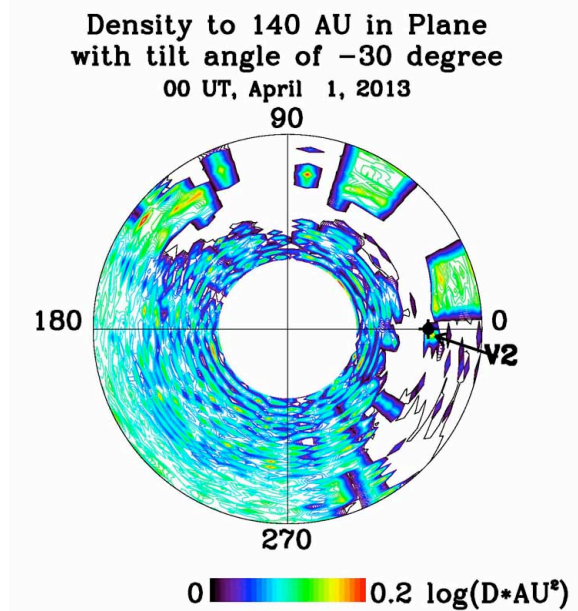

Figure 6. HAFSS plasma density simulations from the Sun to 140 AU in the V2 plane tilted at -30 degrees.

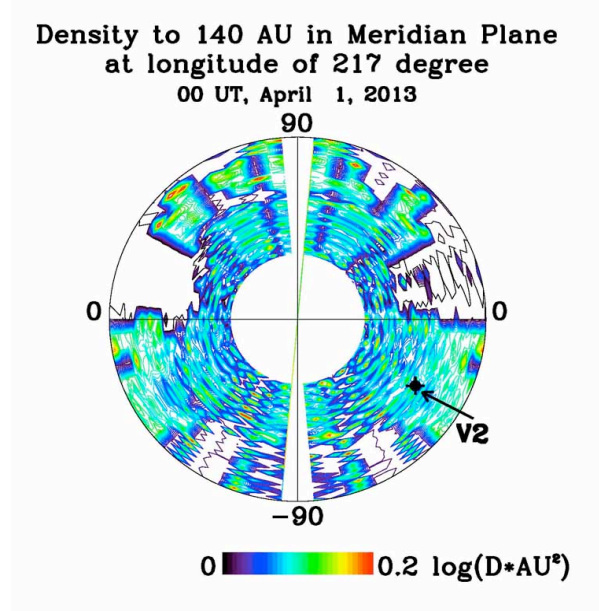

Figure 7. HAFSS plasma density simulations from the Sun to 140 AU in the V2 meridian plane at 217 degrees longitude.

results, which is consistent with the fact that, unlike our 3D MHD time-dependent HHMS-PI model [8,9] that takes account of the decelerating effect of pickup protons on both bulk speed and shock speed, HAFSS does not. Neither HAFSS nor HHMS-PI takes account of the effects of the termination shock or of the heliosheath or of the heliospheric current sheet on the plasma speed and density.

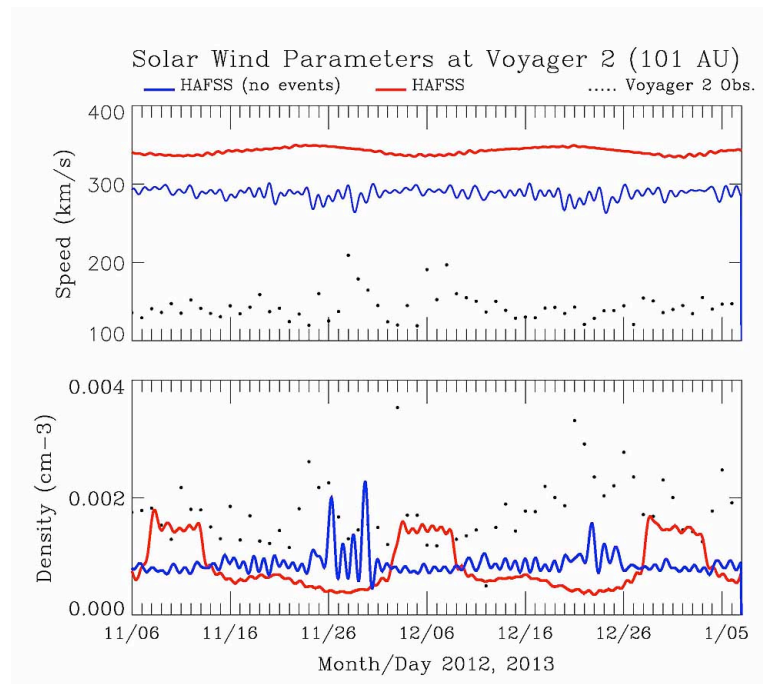

Figure 8. Same as Figure 1 for HAFSS simulations at V2 (at 101 AU) from November 6, 2012 to January 6, 2013.

The density plots in Figure 8 show that there is a similarity between the two modelled plasma density profiles (lower panel) and the data. As noted above, the longer-term trends (e.g., the square waves in the red line and the more irregular rises in the blue line) are genuine predictions and can be seen to correspond roughly to the timing of the peaks in the measured densities. The higher frequency smaller amplitude fluctuations in both lines of HAFSS density predictions are artefacts of the current calculation method. We also note the differences between the HAFSS results based on solely the background solar wind inputs (blue line) and those based on the background solar wind plus the impulsive solar wind inputs (red line). The latter appear to be more similar to the data. Another primary conclusion from the density panel is the overall agreement between the predicted and the actual density magnitudes, which is much closer than the agreement between the magnitudes of the predicted and the actual speeds.

4. HAFSS Comparisons at V1 at 34 degrees North

Figures 9 and 10 are similar in format to Figures 6 and 7, respectively. Figure 9 shows the HAFSS simulation of the plasma density propagation on April 1, 2013 from the Sun out to V1 and beyond to 140 AU in the V1 plane, which is tilted to 34 degrees North and is in an xyz coordinate system in which the 0 axis is the radius from the Sun to V1. Likewise, Figure 10 shows on April 1, 2013 the HAFSS simulation of the plasma density propagation, in the meridian plane at the longitude of V1 at 174 degrees.

Figure 11 is similar in format to Figures 1 and 8, and shows the HAFSS simulation of the plasma speed and density in late March and early April 2013 for the March 2012 solar events propagating from the Sun to V1. As in Figure 8, in these plots the longer-term trends are genuine predictions while the shorter, nearly periodic fluctuations are artefacts. However, there are no PLS plasma observations at V1 since the V1 PLS instrument failed in 1980. Judging from the comparisons with V2 in Figure 8, it seems likely that if PLS data had been available, then comparing the HAFSS modelled profiles of the plasma speed (upper panel) and the actual variations in the measured plasma speed (including increases in the magnitude of the plasma speed starting in March/April 2013) we would have primarily

found a qualitative correspondence in the plasma speed profiles, with the HAFSS speed magnitudes substantially higher, as was the case at V2. Similarly as in Figure 8, it is tempting to consider that the profiles of the modelled plasma densities (lower panel) also might have been indicative of the variations in the measured plasma density if the V1 PLS instrument were operational.

5. Discussion

Previously it already was tempting to conclude, as suggested by [5], that the effects of the March 2012 solar initiated activity could have propagated to and beyond V1 at ~ 123 AU. Now our HAFSS simulations in Figure 11 can be taken as additional evidence that the March 2012 events are plausible candidates for the origin of the 2-3 kHz enhanced signals detected by the V1 PWS during April/May 2013. The speed and density estimates in the HAFSS simulations in Figure 11 show a substantial enhancement in speed at the end of March, followed by higher densities in the first few days of April 2013, only a few days before the actual beginning of the strong PWS activity on April 9. Considering that, as noted above, HAFSS does not take into account either the decelerating effect of pickup protons or any interaction with the termination shock or the heliosheath or the heliospheric current sheet this is remarkably good agreement with the observations. Thus, we are more confident that the March 2012

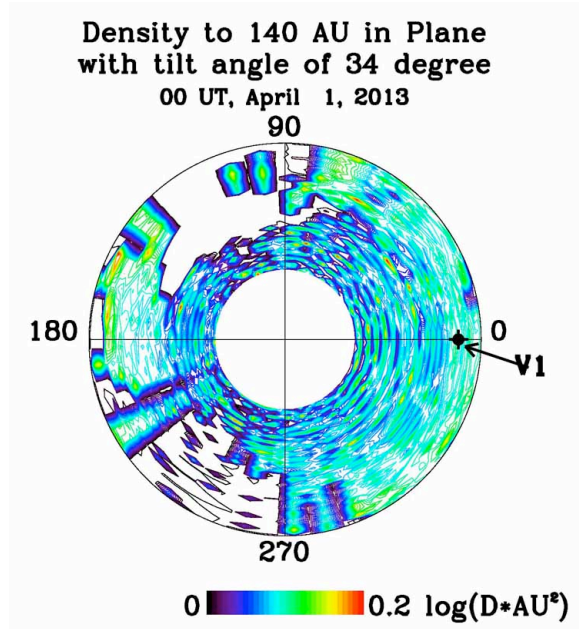

Figure 9. HAFSS plasma density simulations from the Sun to 140 AU in the V1 plane tilted at +34 degrees.

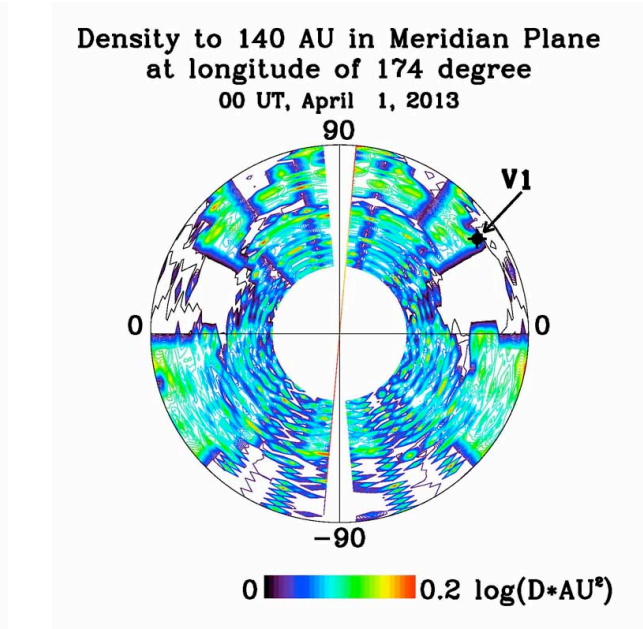

Figure 10. HAFSS plasma density simulations from the Sun to 140 AU in the V1 meridian plane at 174 degrees longitude

solar events could have been responsible for the April-May 2013 2-3 kHz enhanced signals observed by the V1 PWS and their associated increased plasma density measured by the PWS indicating that V1 was in the ISM.

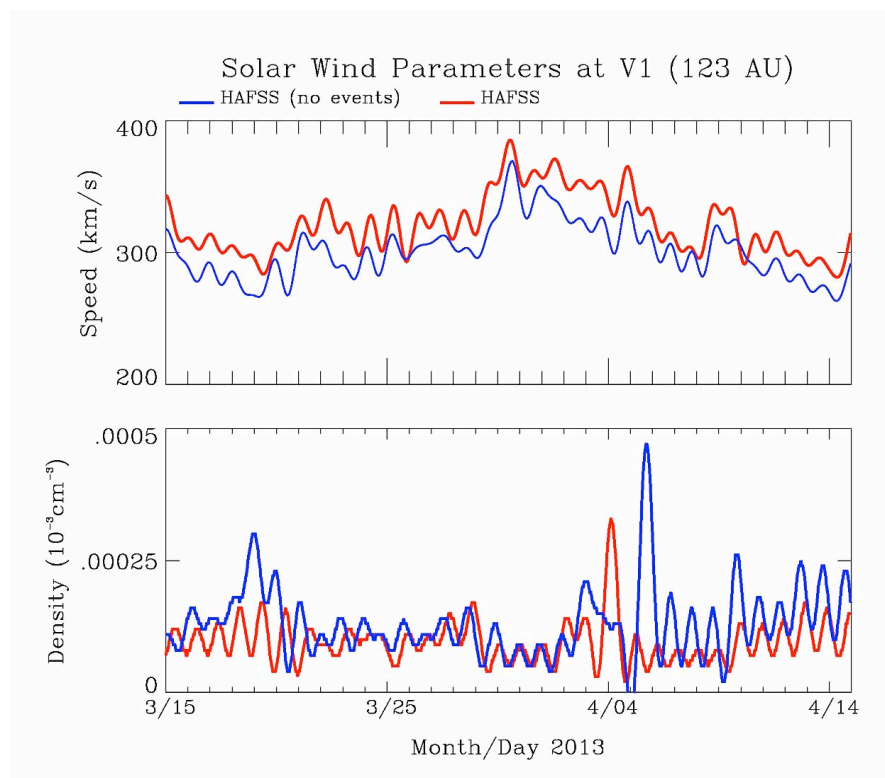

Figure 11. Same as Figure 1 for HAFSS simulations at V1 (at 123 AU) from March 15 to April 15, 2013.

HAFSS is ideally suited for these analyses since it simulates the slowly evolving background solar wind inputs and the impulsive solar wind inputs due to solar event activity. Three-dimensional simulations, including the obviously needed coordinate transformations and the event initiations at or very close to the Sun, are essential for studies of this kind. The large asymmetries in the solar wind flow emphasize the importance of these capabilities. Two-dimensional and certainly 1D simulations that start at Earth or elsewhere are definitely not appropriate in this context.

6. Acknowledgments

We thank the Voyager and OMNI teams, the NSSDC, and NOAA's SWPC for their data. Our work was supported in part by a NASA grant and by Carmel Research Center.

7. References

- [1] Krimigis S M et al., 2013, *Sci*, **341**, 144-147
- [2] Stone E C et al., 2013, *Sci*, **341**, 150-153
- [3] Burlaga, L F, et al., 2013, *Sci*, **341**, 147-150
- [4] Webber W R, and McDonald F B, 2013, *Geophys Res. Lett.*, **40**,1665-1668
- [5] Gurnett D A et al., 2013, *Sci*, **341**, 1489-1492
- [6] Intriligator D S, Sun W, et al., 2008, Particle Acceleration and Transport in the Heliosphere and Beyond (Eds. Li G, Hu Q,Verkhoglyadova O, Zank G, et al.), *AIP* **1039**, 375-383
- [7] Intriligator D S, Sun W, et al., 2005, *J. Geophys. Res.*, **110**, A09S10, doi:10.1029/2004JA010939
- [8] Detman T M, Intriligator D S, et al., 2011, *J. Geophys. Res.*, **116**, A03105, doi:10.1029/2010JA015803
- [9] Intriligator, D S, Detman T M, Gloeckler G, et al., 2012, *J. Geophys. Res.*, **117**, A06104, doi:10.1029/2011JA017424.