

Land use change in a Mediterranean metropolitan region and its periphery: assessment of conservation policies through CORINE Land Cover data and Markov models

P. Ruiz Benito^{1,2*}, J. A. Cuevas^{2,4}, R. Bravo de la Parra³, F. Prieto²,
J. M. García del Barrio^{1,5} and M. A. Zavala^{1,2}

¹ CIFOR-INIA. Ctra. A Coruña, km 7,5. Madrid. Spain

² Departamento de Ecología. Facultad de Ciencias. Universidad de Alcalá.
28871 Alcalá de Henares (Madrid). Spain

³ Departamento de Matemáticas. Universidad de Alcalá. 28871 Alcalá de Henares (Madrid). Spain

⁴ Center for Environmental Research in the Region of Madrid. 2 Almendro St. 28791 Soto del Real (Madrid). Spain

⁵ Instituto Universitario de Gestión Forestal Sostenible. UVA-INIA. Spain

Abstract

Sustainable territorial management requires reliable assessment of the impact of conservation policies on landscape structure and dynamics. Euro-Mediterranean regions present a remarkable biodiversity which is linked in part to traditional land use practices and which is currently threatened by global change. The effectiveness of one-decade conservation policies against land use changes was examined in Central Spain (Madrid Autonomous Community). A Markov model of landscape dynamics was parameterized with CORINE Land Cover information and transition matrices were obtained. The methods were applied in both protected and unprotected areas to examine whether the intensity and direction of key land use changes —urbanisation, agricultural intensification and land abandonment— differed significantly depending on the protection status of those areas. Protected areas experienced slower rates of agricultural intensification processes and faster rates of land abandonment, with respect to those which occurred in unprotected areas. It illustrates how simple mathematical tools and models —parameterized with available data— can provide to managers and policy makers useful indicators for conservation policy assessment and identification of land use transitions.

Key words: global change; land use and land cover change; traditional and cultural land uses; protected areas and protection categories.

Resumen

Cambio en el uso del suelo en una región Mediterránea metropolitana y su periferia: evaluación de las políticas de conservación mediante datos del CORINE Land Cover y modelos de Markov

La gestión sostenible del territorio requiere de análisis realistas sobre el impacto de las políticas de conservación en la estructura y dinámica del paisaje. La región Euro-Mediterránea presenta una biodiversidad remarcable que está unida en parte a las prácticas tradicionales del uso del suelo y que actualmente está amenazada por el cambio global. La efectividad de la implantación de políticas de conservación frente a los cambios en el uso del suelo fue examinada en el centro de España (Comunidad Autónoma de Madrid). Se usaron modelos de Markov para analizar la dinámica del paisaje parametrizados con información del CORINE Land Cover y se obtuvieron las matrices de transición. La metodología se aplicó en áreas protegidas y no protegidas para examinar si la intensidad y dirección de los cambios del uso del suelo claves —urbanización, intensificación agrícola y abandono— difieren significativamente en función del grado de protección. Las áreas protegidas experimentaron menores tasas en el proceso de intensificación agrícola y mayores en el abandono con respecto a las ocurridas en zonas sin protección. Se demuestra cómo modelos y herramientas matemáticas —parametrizados con los datos disponibles— pueden proporcionar a gestores y políticos indicadores útiles para la evaluación de políticas de conservación e identificación de transiciones de uso del suelo.

Palabras clave: cambio global; cambios en el uso y cobertura del suelo; usos del suelo tradicionales y culturales; áreas protegidas; figuras de protección.

* Corresponding author: ruiz.paloma@inia.es

Received: 12-02-10; Accepted: 09-07-10.

Introduction

Global change is a major threat for biodiversity in ecosystems with potential species losses due to habitat loss, fragmentation and climatic changes (Heywood and Dulloo, 2005). Land use and land cover changes are the result of both human activities and ecological processes (Turner, 1987; Petit and Lambin, 2002) and they are considered one of the major components of global change (Lambin *et al.*, 1999; Foley *et al.*, 2005). Conservation policies are critical to ameliorate their potential negative effects on ecosystem structure and function, and the assessment of their effects has become a key issue in conservation ecology (Chape *et al.*, 2005; Hoekstra, 2008).

The Mediterranean Basin harbours a rather high diversity of communities and traditional landscapes created and maintained by human activity over the last millennia (Blondel and Aronson, 1995; Naveh, 1987), and it is considered one of the hotspots most threatened by habitat loss (Brooks *et al.*, 2002). In this region, both traditional and cultural landscapes have been created and maintained by human activity linked to abiotic complexity (Blondel, 2006), chiefly traditional land use such as agricultural and sylvopastoral systems (González-Bernáldez, 1991; Buisson and Duitot, 2006). This land use practice has resulted in agroecosystems of high diversity (Marañón, 1988).

Global anthropogenic changes around the Mediterranean Basin have had major impacts on the dynamics and the maintenance of biodiversity on all scales (Blondel y Aronson, 1995). Global change presents, in terms of land use change, two opposite contrasting trends. On one hand, both extreme industrial development and urbanisation are reshaping these landscapes again (*e.g.*, Gunlinck *et al.*, 2001; Antrop, 2004; Wasilewski and Krukowski, 2004). On the other hand, rural abandonment and cessation of traditional practices can result in a loss of biodiversity, especially in the Mediterranean Basin (Naveh, 1971). Both intensification of human perturbations and their cessation are interfering with biodiversity preservation in this region (Blondel and Aronson, 1995), and the establishment and assessment of conservation strategies inside and outside of protected areas are needed (MMA, 2005).

In the Mediterranean region, protection categories have been generally established on the basis of administrative delimitations of territorial fragments, with emphasis on species/areas conservation (Mora, 2003). Furthermore, the development of integrated and dynamic

regional assessment tools is essential to the selection of appropriate criteria and methodologies for management. Policies should be readjusted or modified according to territorial changes under different methodologies and perspectives, whether the main target is species conservation (*e.g.*, Araujo *et al.*, 2007) or habitat preservation (*e.g.*, Rodrigues and Gaston, 2001). In this study, the effectiveness of conservation policies in Madrid and its periphery —one of the most highly populated EU Mediterranean regions— were assessed. The Madrid Autonomous Community (hereafter MAC) harbours a rich ecosystem diversity with a number of traditional landscapes ranging from cool temperate forest at high elevation (> 1,500 m) to semi-arid woodlands. On the other hand, it constitutes a good example of dramatic land use change including both land abandonment and urban expansion: artificial surfaces have increased 47.7% during the 1987-2000 period, while agricultural areas and forest areas have decreased 8.9% and 0.7% respectively (OSE, 2006).

Landscape models allow us to recognise the main components of land use change, like urbanisation, agricultural intensification or land abandonment, as well as the subjacent driving forces (Baker, 1989). A variety of different land use and land cover change models has been developed (Briassoulis, 2000; Brown *et al.*, 2004). For example, land use and land cover change simulations have been performed with statistical models throughout regression techniques (Aspinall, 2004), cellular automata models based on neighbourhood influence in transitions (Straatman *et al.*, 2004) or agent-based model focused on human actions (Parker *et al.*, 2003). Complex models are a powerful tool, but they tend to be difficult to parameterize and costly, so simple tools and models are useful for policy assessment which often requires rapid and simple evaluations based upon available data. In this context, Markov chains represent a useful tool to describe the consequences of land use changes, if the same driving forces continue in the future (Briassoulis, 2000). Transition matrices and Markov models of landscape dynamics were parameterized based on the CORINE Land Cover 1990-2000 dataset, to address the following issues: Firstly, the intensity and direction of the components of main land use changes were examined —chiefly urbanisation, agricultural intensification and land abandonment— identifying if they are substantially different in both protected and unprotected areas. Moreover, by means of Markov lineal simulation we explore the landscape change tendencies under the action of similar

driving forces in protected and unprotected areas. Secondly, this method was applied to each type of protection category present in MAC.

Methods

Land cover data of MAC was taken from the satellite remote sensing database I&CLC2000 of the CORINE Land Cover project (EEA, 2002) at two dates, 1987 (CLC90 revised) and 2000 (CLC00) in Spain. The CORINE Land Cover is a pan-European project, recognised by decision-makers as a key reference data set for spatial and territorial analysis at different territorial levels (Büttner *et al.*, 2002). CORINE Land Cover dataset has a common nomenclature established on three hierarchically structured levels of land cover at the European level (Table 1). The I&CLC2000 project

presented a minimum mapping unit of 25 ha, minimum width of 100 m and scale 1:100,000, where the thematic accuracy was higher or equal to 85% in CLC90 and CLC00 (EEA, 2007), validated for the second one (Büttner and Maucha, 2006). The poorer geometric and thematic accuracy of IMAGE90 was mostly corrected in the I&CLC00 project (EEA, 2007), although the geometric accuracy of satellite images was different (Büttner *et al.*, 2002). For this reason the CLC90 revised version from I&CLC00 project was selected. The vectorial databases were incorporated into a geographic information system using ArcView Gis 9.2 (ESRI Inc., Redlands, California, USA) to assist the cell-based transition-matrix analysis of land use change (cell processing size of 100 × 100 m).

For the selection of different protection categories, the definition of protected area from the Convention of Biological Diversity (United Nations, 1992) and

Table 1. CORINE Land Cover nomenclature of the states used in the transition matrices and Markov chains in, corresponding to the three different levels of CORINE, with a brief description of the states at third level of CORINE (Bossard *et al.*, 2000)

Level 1	Level 2	Level 3	
(1) Artificial surfaces	(11) Urban fabric + Artificial non-agricultural vegetated areas	(111) <i>Continuous urban fabric + Discontinuous urban fabric + Green urban areas + Sport and leisure facilities:</i> Areas mainly covered by dwellings and buildings, or coluntary created to recreational use.	
	(12) Industrial, commercial and transport unit	(121) <i>Industrial or commercial units:</i> Areas mainly occupied by industrial activities.	
		(122) <i>Road and rail networks and associated land + Airport:</i> Motorways and railways, including associated installations, port areas and airports.	
(2) Agricultural areas	(13) Mine, dump and construction sites	(131) <i>Mineral extraction sites + Dump sites + Construction sites:</i> Artificial areas mainly occupied by extractive activities, dump-site, construction sites and their related lands.	
		(21) Arable land + Permanent crops	(211) <i>Non-irrigated arable land:</i> It includes flower, fruit trees (nurseries), vegetable cultivation, and other annually harvested plants (> 75% of the area under a rotation systems).
			(212) <i>Permanently irrigated land:</i> Crops irrigated permanently or periodically, using a permanent infrastructure (irrigation channels, drainage network).
	(221) <i>Vineyards:</i> Areas planted with vines.		
	(222) <i>Fruit trees and berry plantations:</i> Parcels planted with fruit trees or shrubs.		
	(223) <i>Olive groves:</i> Areas planted with olive trees, including mixed of olive trees and vines on the same parcel.		
	(23) Pastures	(231) <i>Pastures:</i> Lands used for fodder production (at least 5 years).	

Table 1 (cont.). CORINE Land Cover nomenclature of the states used in the transition matrices and Markov chains in, corresponding to the three different levels of CORINE, with a brief description of the states at third level of CORINE (Bossard *et al.*, 2000)

Level 1	Level 2	Level 3	
(3) Forest and seminatural areas	(24) Heterogeneous agricultural areas	(242) <i>Complex cultivations:</i> Juxtaposition of small parcels of diverse annual crops, pasture and/or permanent crops.	
		(243) <i>Land principally occupied by agriculture, with significant areas of natural vegetation:</i> Areas principally occupied by agriculture, interspersed with significant natural areas.	
		(244) <i>Agroforestry areas:</i> Annual crops or grazing land under the wooded cover of forestry species.	
	(31) Forest	(311) <i>Broad-leaved forest:</i> Crown cover > 30% or a 500 subjects/ha density for plantation, broad-leaved trees represent > 75% of the planting pattern. In young plants is at least 75% of the total amount of plants.	
			(312) <i>Coniferous forest:</i> Coniferous trees represent > 75 % of the formation. In case of young plants is at least 75 % of the total amount of plants and their texture is very similar to a surrounding coniferous.
			(313) <i>Mixed forest:</i> Crown cover > 30% or a 500 subjects/ha density for plantation. The share of coniferous or broad-leaved species ≤ 25%.
		(32) Shrub and/or herbaceous vegetation associations	(321) <i>Natural grassland:</i> Herbaceous with maximum height of 150 cm and gramineous species are prevailing, which cover ≥ 75% of vegetation developed under a minimum human interference.
			(323) <i>Sclerophyllous vegetation:</i> This class includes evergreen sclerophyllous bushes and scrubs which compose maquis, garrigue, matorral and phrygana.
			(324) <i>Transitional woodland shrub:</i> Bushy or herbaceous vegetation with scattered trees.
			(331) <i>Sand plains:</i> Supra-littoral beaches and dunes developed at the back of the beach from high water mark towards land.
			(332) <i>Bare rock:</i> Scree, cliffs, rock outcrops, including active erosion, rocks and reef flats situated above the high-water mark, including sparsely vegetated areas where 75% of the land surface is covered by rocks.
			(333) <i>Sparsely vegetated areas:</i> Includes steppes, tundra and badlands. Scattered high-altitude vegetation, including sparsely vegetated areas where the vegetation layer covers between 15% and 50% of the surface.
(334) <i>Burnt areas:</i> Includes burnt forest areas, moors and heathlands, transitory forest-shrub formations, areas with sparse vegetation.			
	(512) <i>Inland water:</i> Lakes, ponds and pools of natural fresh water, rivers and streams and man-made fresh water bodies including reservoirs and canals.		
(5) Water bodies	(51) Water bodies	(512) <i>Inland water:</i> Lakes, ponds and pools of natural fresh water, rivers and streams and man-made fresh water bodies including reservoirs and canals.	

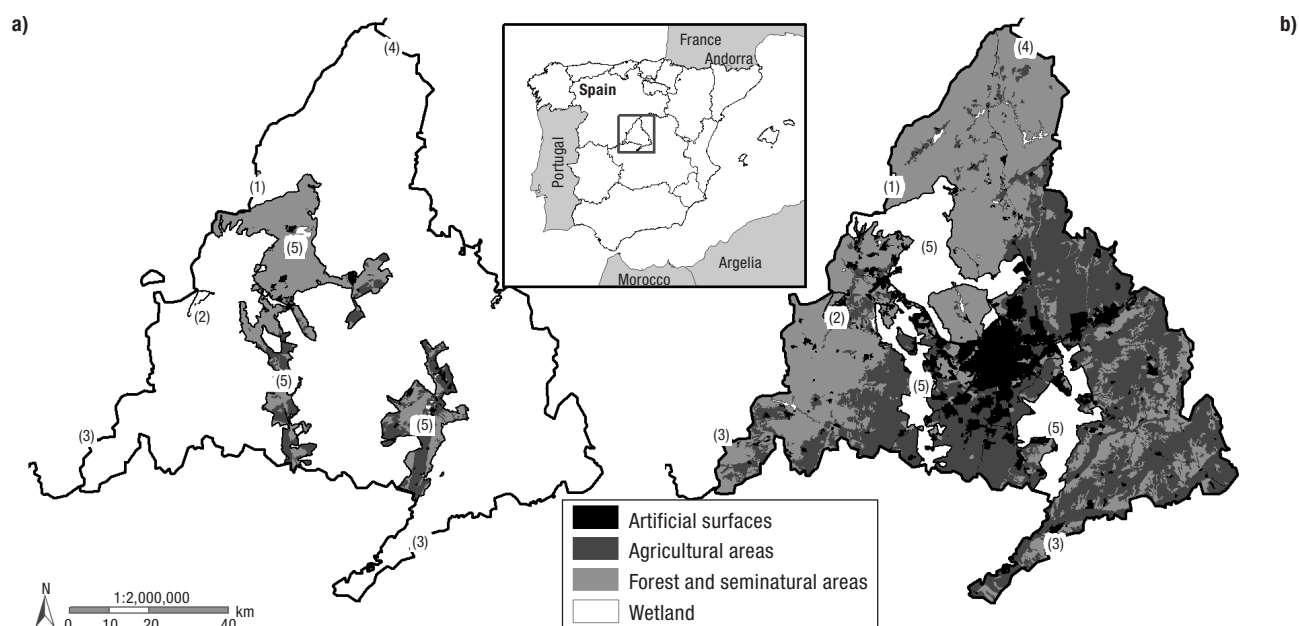

Figure 1. Land cover in the first level of CORINE Land Cover in Madrid Community Autonomous: a) protected and b) unprotected areas. Protected areas include the protection categories included identified in the study: (1) Natural Park, (2) Nature Place, (3) Nature Reserve, (4) Site of National Interest, (5) Regional Park.

IUCN (1994) was considered. The national designation type or protection categories considered (Fig. 1) were those with significant area and object of legal declaration in dates around 1987 and always before 2000—the second data collection in the CORINE Program—(Ta-

ble 2). The Natura 2000 network has not been considered in the analysis because this protection category has not been established in Madrid in 1987.

Markov models of land use change at different classification levels were constructed by estimating

Table 2. Protected areas included the name, date of declaration, area (ha) and percentage public and private (%), date of national legislative instruments PNRM (Plan of Natural Resource Management) and MPUM (Master Plan of Use and Management)*

Protection category	Name	Date declaration	Total area (ha)	Public area (%)	Private area (%)	Date PNRM	Date MPUM
Natural Park	Cumbre, Circo y Lagunas de Peñalara	15/06/1990	768	95	5	2002	2003
Nature Reserve	El Regajal-Mar de Ontígola	18/07/1994	629	1	99	2002	—
Site of National Interest	Hayedo de Montejo de la Sierra	10/10/1974	250	100	0	—	—
Regional Park	Cuenca Alta del Manzanares	08/02/1985	52,796	30	70	—	1987
	Curso Medio del Río Guadarrama y su entorno	24/05/1999	22,116	—	—	1999	—
	En torno a los ejes de los cursos bajo de los ríos Manzanares y Jarama	12/07/1994	31,550	12	88	1999	—
Nature Place	Pinar de Abantos y Zona de la Herrería del Real Sitio de San Lorenzo del Escorial	17/12/1961	1,539	81	19	—	—

* Information obtained from database of Europarc-Spain (Europarc-España, 2007) and European Environmental Agency (EEA, 2009).

the corresponding transition probabilities. Markov chains have long been used in modelling changes of land use and land cover at a variety of spatial scales (e.g., Weng, 2002). In a Markov chain there is a set of m outcomes, $\{u_1, u_2, \dots, u_m\}$, in our case land cover types. To describe the entire chain it is sufficient, for each i and j , to define the transition probability p_{ij} representing the probability that a cell of cover type u_i changes into cover type u_j in the next time step. The transition probabilities are gathered in the transition matrix $P = (p_{ij})$ and denoting Y_t the vector of land use proportions at time t we obtain Y_{t+1} (Briassoulis, 2000) by means of the following equation:

$$Y_{t+1} = Y_t \cdot P \quad [1]$$

The transition probabilities were obtained from the years 1987 and 2000 of I&CLC2000 database, by means of cross-tabulation tools, after raster maps of land cover were extracted. The fact of using 1987 and 2000 data implies that the time unit in [1], the time elapsed between t and $t+1$, is taken to be 13 years. Cross tabulation tools were used for building transition matrices for each one of the three first levels of CORINE land cover (Table 1) distinguishing between both protected and unprotected areas. In the first level of CORINE nomenclature, four states (*i.e.* different typologies of land use) were used, ten states at the second one and twenty four states in the third one (Table 1), thus six transition matrices were elaborated. Differences between the proportion of existing states in protected and unprotected areas were tested using chi-square tests based on observed frequency (Kadmon and Harari-Kremer, 1999), in 1987 and 2000. In order to be able to determine how the extension and year of declaration of each protection category have affected the territory evolution, the landscape dynamic model (and categories showed in Table 1) has been applied for each protection category in this study. In this application of specific location (Fig. 1) not all of the land uses defined in CORINE will be considered as states in the transition matrix.

Once the transition matrices are obtained, we use equation [1] to project Y_0 , the vector of initial land use proportions, and obtain Y_t just by multiplying by the t -power of matrix P :

$$Y_t = Y_0 \cdot P^t \quad [2]$$

We also use the property of the class of regular Markov matrices which establishes the same long term land use distribution for any initial distribution. A Markov matrix (or chain) is regular if there exists a fixed time t^* such that the probability of transition from any state u_i at

time 0 to any state u_j at time t^* is positive, this equivalent to matrix P^{t^*} having positive all its entries. The Markov matrices we use for the first level of CORINE are regular, in fact matrix P in these cases has positive entries so in a single period of time, $t^* = 1$, there is a strictly positive probability of changing from any land use u_i to any land use u_j .

The long term, or stationary, distribution, $Y^* = (y_1^*, y_2^*, \dots, y_m^*)$, associated to a regular Markov matrix is the only solution of system

$$Y^* = Y^* \cdot P, \quad [3]$$

verifying $y_1^* + y_2^* + \dots + y_m^* = 1$ (Roberts, 1976). The powers P^t of matrix P approach a matrix with all its rows equal to Y^* , what can be used as an alternative method to calculate the stationary distribution. Using these two forms to obtain Y^* allows to estimate the relative time to reach this stationary distribution and compared it in protected and unprotected areas. This time is an indicator of the rapidity of change reached in the system. Most of the Markov transition matrices that we propose for the second and third level of CORINE data are not regular so our analysis is limited to the transition matrices.

Results

Changes in land use of protected and unprotected areas

Land use changes dynamics at the first level of CORINE data (see Fig. 2) showed that the urbanization process achieves higher rates in unprotected areas (6.2% from agricultural and 3.1% from forest) than in protected areas (4.5% from agricultural and 1.4% from forest). At second and third level of CORINE data (Table 1), the urbanization process of agricultural and natural areas has come from an elevated number of classes and with higher intensity in unprotected areas. In unprotected areas the urbanization processes affected all categories of agricultural areas—arable lands, permanent crops, pastures and heterogeneous agricultural areas—and forest and semi-natural areas, especially to shrub and herbaceous vegetation (Table 3).

The transitions from artificial areas to agricultural and natural ones reached higher rates in protected areas (1.9% and 4.7% respectively) than in unprotected areas (0.1% and 0.2% respectively) (Fig. 2). The transition matrices at second level (Table 3) show that this transi-

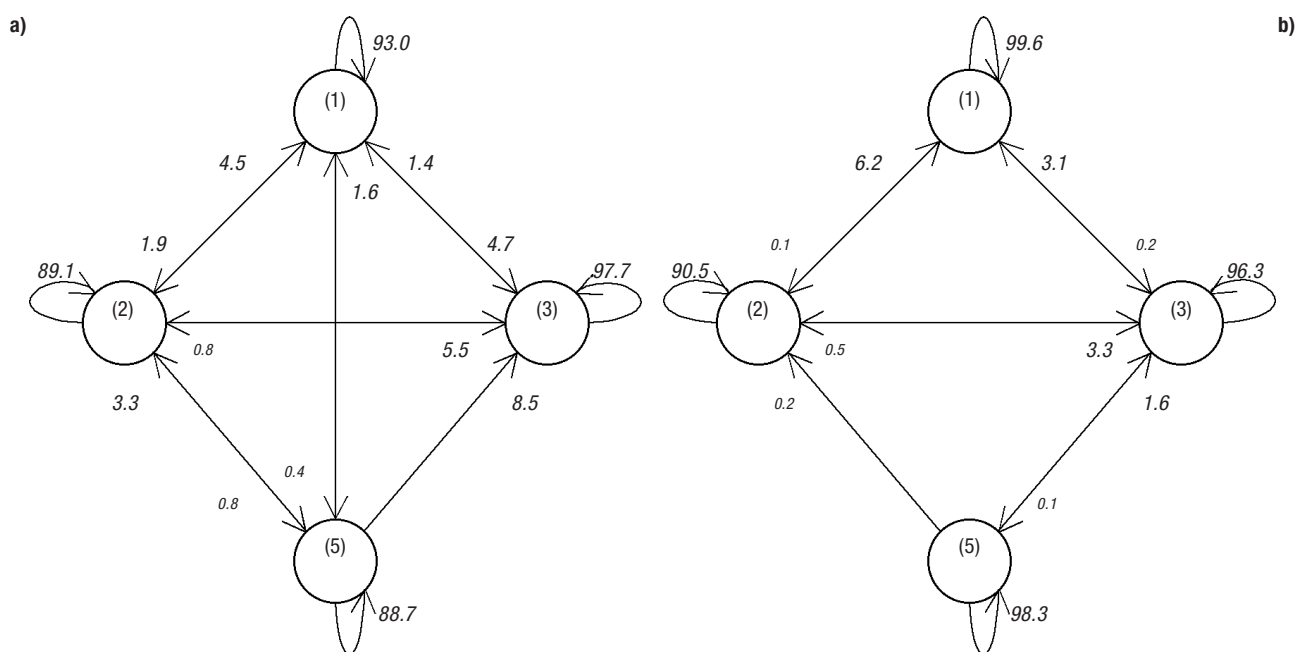

Figure 2. Land use changes-graph of a Markov chain model (percentage) in protected areas a) and unprotected areas b) of: (1) artificial surfaces, (2) agricultural areas, (3) forest and semi-natural zones and (5) water bodies, Madrid Region, Spain, 1987-2000.

Table 3. Transition matrices with probability of change (percentage) in (A) protected and (B) unprotected areas where rows show states in 1987 and columns in 2000, at second level of CORINE Land Cover (see Table 1)

	(11)	(12)	(13)	(21)	(23)	(24)	(31)	(32)	(33)	(51)
A)										
(11)	100.0	0.0	0.0	0.0	0.0	0.0	0.0	0.0	0.0	0.0
(12)	0.0	100.0	0.0	0.0	0.0	0.0	0.0	0.0	0.0	0.0
(13)	17.0	13.7	48.7	5.7	0.0	0.0	0.0	13.8	0.0	0.0
(21)	1.9	0.3	2.4	86.1	0.0	0.7	0.0	7.4	0.0	0.0
(23)	0.8	0.0	0.0	0.0	99.2	0.0	0.0	0.0	0.0	0.0
(24)	0.6	0.0	3.6	0.2	0.0	95.0	0.0	0.5	0.0	0.0
(31)	0.1	0.0	0.0	0.0	0.0	0.1	99.2	0.0	0.6	0.0
(32)	1.3	0.3	0.2	1.0	0.0	0.0	0.1	96.7	0.3	0.0
(33)	0.0	0.0	0.0	1.1	0.0	0.0	0.0	40.0	58.9	0.0
(51)	0.0	0.0	0.0	0.0	0.0	0.0	0.0	0.0	0.0	100.0
B)										
(11)	99.2	0.6	0.1	0.1	0.0	0.0	0.0	0.0	0.0	0.0
(12)	0.8	99.1	0.0	0.0	0.0	0.0	0.0	0.1	0.0	0.0
(13)	55.7	13.5	26.0	1.4	0.0	0.0	0.3	3.1	0.0	0.0
(21)	2.7	2.6	2.5	87.5	0.0	1.0	0.1	3.7	0.0	0.0
(23)	4.2	0.0	0.0	0.0	94.0	0.00	0.9	0.7	0.0	0.1
(24)	1.0	0.2	0.9	0.4	0.0	95.7	0.1	1.6	0.1	0.0
(31)	0.4	0.1	0.0	0.0	0.0	0.0	97.7	0.5	1.3	0.0
(32)	2.4	0.8	0.7	0.3	0.0	0.3	0.8	94.6	0.1	0.1
(33)	0.0	0.5	0.2	0.0	0.2	0.0	0.0	19.7	75.6	3.9
(51)	0.0	0.0	0.0	0.0	0.0	0.2	0.0	1.4	0.2	98.3

tion is produced mainly by the restoration of mine, dump and construction zones going mainly to crops and arable areas and shrub and/or herbaceous vegetation.

Agricultural intensification was higher in unprotected areas, marked by the transition of non-irrigated to permanent irrigated, with 6.02% in unprotected areas *versus* 3.02% in protected areas (third level of CORINE). This agricultural intensification was also shown by the transitions of heterogeneous agricultural areas to arable land and permanent crops, with a double intensity in unprotected areas than in protected ones (Table 3).

Land abandonment was achieved by transformations of agricultural areas to forest and semi-natural areas (Fig. 2). In this abandonment process the intensity is higher in protected areas (5.5%) and is composed mainly of transformations of arable land and permanent crops to shrub and herbaceous vegetation (7.4%, Table 3a). In spite of the less intensity of land abandonment observed in unprotected areas, the process affected to pastures and heterogeneous agricultural areas more intensively (Table 3b).

In protected areas, a lower intensity of the transitions from forest and semi-natural areas to other land uses was observed (Fig. 2). Specifically, forest and semi-natural areas changed to artificial surfaces with a rate of 1.4% and to agricultural areas with a rate 0.8%, while in unprotected areas these transition probabilities rates were of 3.1% and 0.5% respectively (Fig. 2). The land uses most affected by the transitions to artificial surfaces have been shrub and/or herbaceous vegetation associations, and the intensity of change is higher in unprotected areas (Table 3). Higher stability of protected land was observed in forest and seminatural areas (Fig. 3). An exception was observed in open spaces, which at third level of CORINE data experienced changes to all classes of shrub or herbaceous vegetation. In unprotected areas, a high loss of coniferous forest (1.8%) and mixed forest (4.3%) was noticed from the transformation in burnt areas at third level of CORINE data (Table 1). In protected areas was observed a higher transition probability from water bodies to the rest of classes at first level of CORINE land Cover (Fig. 2).

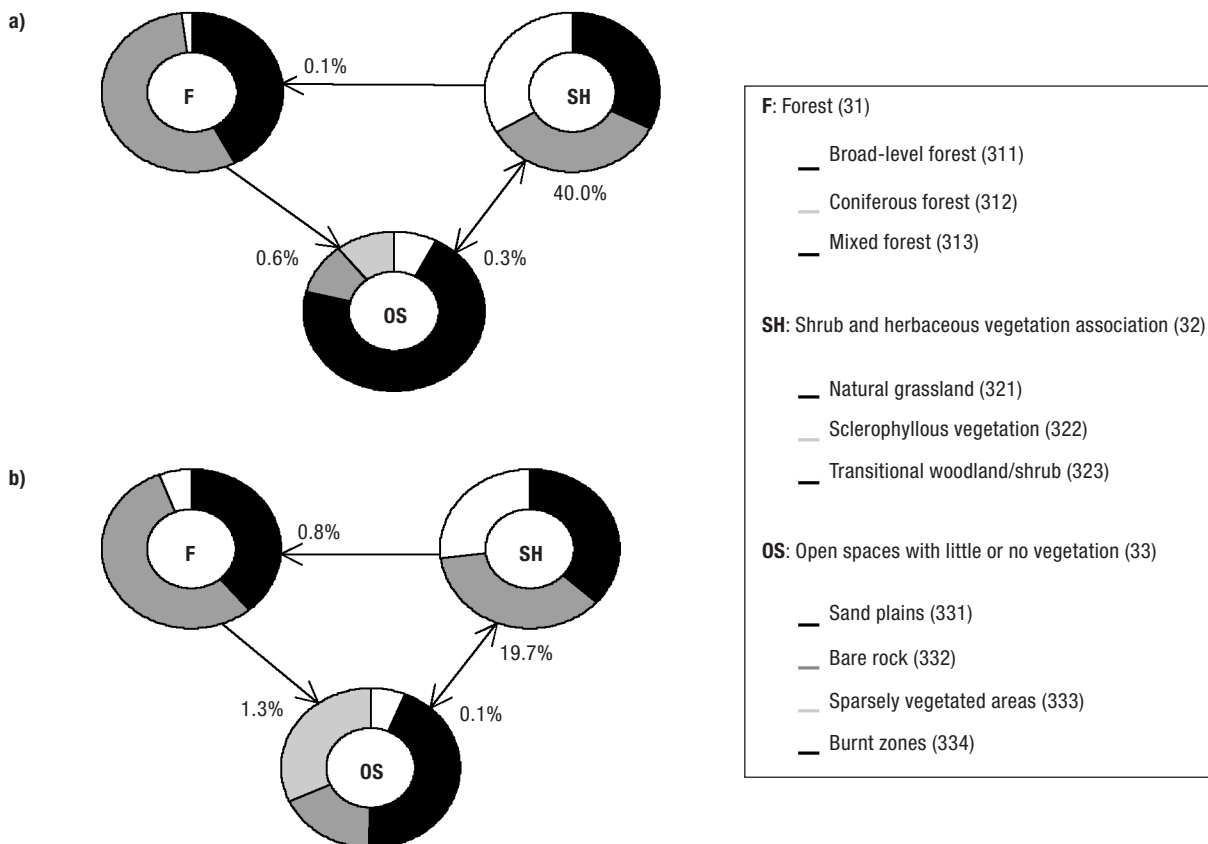

Figure 3. Forest and semi-natural changes process, with transition probabilities for the second level transition matrix of the CORINE data set (1987-2000) and percent of each category of third level of CORINE in 2000. In protected areas a) and unprotected areas b), MAC, Spain.

The results at third level of CORINE showed that it was mainly due to changes from inland water.

Limit distributions simulated at first level of CORINE data if the driving forces that acted in the territory continue were very different between protected and unprotected areas. Simulation results of lineal trends showed that in about 130 years (year 2130) the surface occupied by the artificial surfaces would surpass the forest and seminatural areas (Fig. 4), together with a loss of agricultural areas. In protected areas, the trend was very different. Forest zones dominated, with a higher proportion of agricultural areas and bodies of

water. In lineal land cover change simulation the forest and seminatural areas increased their area, remaining practically constant from their initial state. In protected areas, artificial areas gradually experienced gains from the agricultural areas (Fig. 4). Once the limit distribution is reached in protected areas the proportion of artificial surfaces, agricultural areas, forest and semi-natural areas and water bodies was of 20.5%, 9.3%, 68.7% and 1.5% of total surface respectively. Very different limit distribution proportions were reached in unprotected areas considering a stationary change not variant in time (90.4%, 1.6%, 7.6% and 0.4% respectively). In unprotected areas, the relative time required to reach this limit distribution was shorter than in protected areas with a rate of 1:5.3, if changes occurred between 1987 and 2000 continue. Significant differences have been observed between protected areas and unprotected areas, both for 1987 ($X^2=9.2$; $P<0.01$) and for 2000 ($X^2=9.8$; $P<0.01$).

Effects of the different types of protection categories

In protected areas differences were observed according to the type of protection category (see Fig. 5). Some protection categories only included forest and semi-natural areas. This was the case of the Site of National Interest and Nature Park, comprising forest and shrubland zones (Fig. 5). The transition observed in Site of National Interest was a change of 29% shrubland towards forest zones, mainly marked by the change from natural grassland to conifers (Fig. 5). Natural Park was made up of classes of forests, shrubland and highly stable open spaces that resist change over the time period considered. The remaining protection categories presented agricultural and artificial land uses, which interact with the forest and seminatural areas in Natural Reserve and Regional Park (Fig. 5).

Large changes in Nature Place have been taken place from the heterogeneous agricultural zones —agroforestry zones— towards urban zones, but forest and seminatural areas had a marked isolated character (Fig. 5). With regards to natural processes, transitions in forest and seminatural areas involved a degradation, by conversion to burnt areas from sclerophyllous vegetation and conifer forests. In Nature Reserve areas, artificial and agricultural classes can be observed, in spite of its small area (Table 2). The forest zones were only represented by shrubland —sclerophyllous vege-

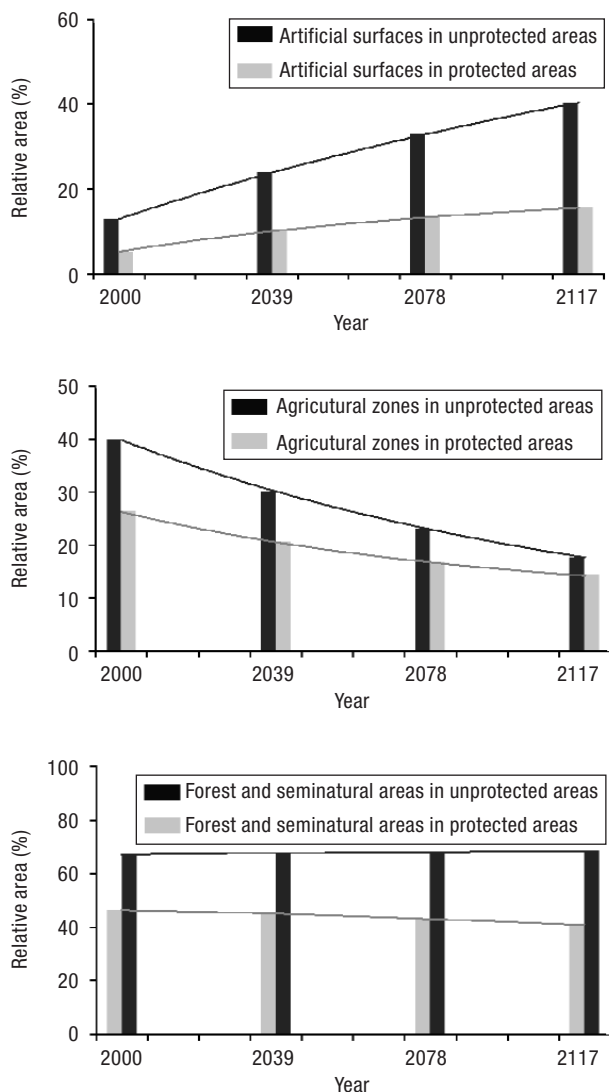

Figure 4. Relative area of artificial surfaces, agricultural areas and forest and seminatural areas in the first 10 time steps simulated from the transition matrix (1987-2000) in protected and unprotected areas.

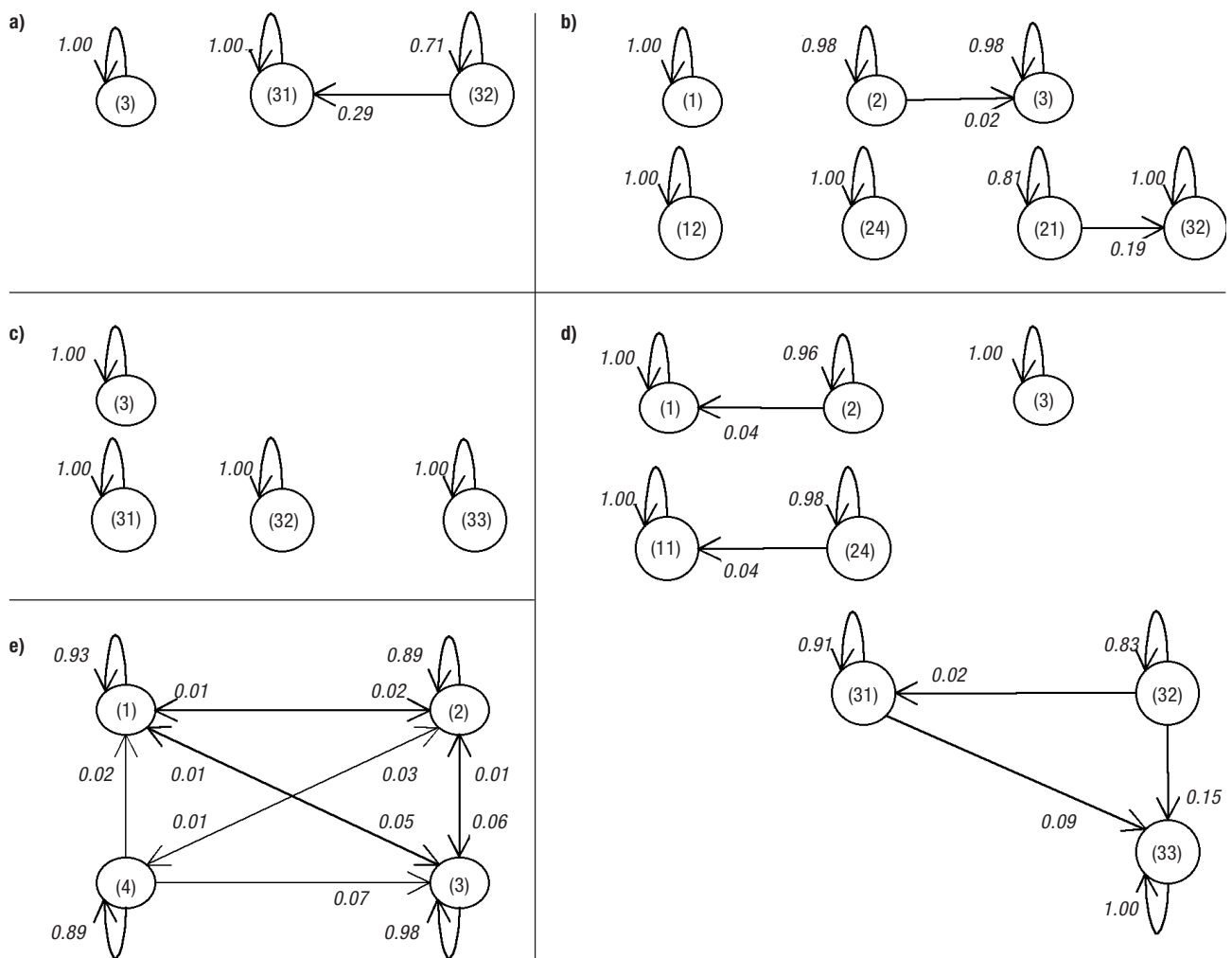

Figure 5. Directed graph of a Markov chain model, with transition probabilities at first and second level —except Regional Park which only shows first level— of CORINE nomenclature (see Table 1) of different protection categories: a) Site of National Interest, b) Nature Reserve, c) Natural Park, d) Nature Place and (e) Regional Park.

tation—, with inputs from permanent irrigated lands (Fig. 5). Finally, Regional Parks constitute the protection statuses covering the largest areas (Table 2), with tendencies similar to those observed in protected areas.

Discussion

Our results show that the protection of areas has reduced the intensity of agricultural and urbanisation activities, whereas it was associated with a more severe land abandonment. Despite this, whole territory management has not reached the optimum of the conservation *versus* development dichotomy, because higher rates of intensification and cessation of anthropic traditional transitions in unprotected areas were ob-

served. In MAC irreversible transitions have been observed and have affected different traditional and cultural Mediterranean landscapes. Intensive land use changes like urbanisation have had an effect on landscapes such as pastures, heterogeneous agricultural areas, shrubs and herbaceous transformations (Table 3). These intensive transitions like urbanisation are linked to the biodiversity process and species richness, with changes in species richness and composition along the urban-rural gradient (McKinney, 2002). The Mediterranean region presents remarkable biodiversity (Myers *et al.*, 2000), which is linked in part to traditional land use practices and the fact that it is currently threatened by global change, both because of management intensification and traditional land use release.

Simulation in unprotected areas has shown that if the same driving forces that had acted between 1987 and 2000 continue the intensification rates can play a vital role in the whole landscape, especially urbanisation. The trends observed in protected areas were very different, because the intensification rates have been slower than those observed in unprotected areas. Foley *et al.* (2005) defined a sequence of five land use regimes by means of land use transitions, from natural ecosystems to intensively modified lands. The methods applied allowed us to identify that MAC was evolving towards an intensive regime. In this land use regime, protected areas achieve higher importance in the territory as tools for habitat preservation.

Although land abandonment processes were more intense in protected areas, the transformation of pastures and heterogeneous agricultural areas was more acute in unprotected areas. This land abandonment, especially important in the Mediterranean region, will have undesirable effects on biodiversity conservation (González-Bernáldez, 1991), being caused by human population abandonment of the rural environment (Mora, 2003; Peña *et al.*, 2006). The abandonment of traditional land use system results in a loss of pastoral value, soil erosion, fire risk and decrease in biodiversity and threats to vulnerable species (González-Bernáldez, 1991).

Protection category analyses showed that protected areas had an initial predisposition to present relevant differences in land cover changes, different in each category studied. Some protected areas have been declared considering the great proportion of natural areas, being the only land use included in several cases (*e.g.*, Natural Park). In this sense, low surface protected areas presented a higher proportion of forest and semi-natural areas. Usually, the boundaries of protected areas are determined by the naturally changing abiotic conditions or by conflicting land use categories (Mora, 2003). The trends observed in Regional Park were similar to those of the protected area as a whole, due to its larger surface (97% of protected areas, see Table 2). Other protection categories showed high habitat persistence, especially forests in Site of National Interest and Natural Park. The intense transitions produced towards artificial landscapes in all the territory have been stopped thanks to the protection of the territory, in zones that by themselves already had high ecological integrity.

The changing patterns of land use in territories have been studied by other authors (Hathout, 2002; Verburg

et al., 2006). Data from the CORINE project allowed straightforward parameterization and implementation of the model, permitting the analysis of suitability of conservation policies, and the differences based on the protection category present. CORINE Land Cover also permits an evaluation and comparison to larger extents, such as national or European evaluation of conservation policies (*e.g.*, Ruiz-Benito *et al.*, 2009), being the methodology presented here easily transferable. However, different resolution of original satellite images and methodologies in the first two editions of CORINE Land Cover resulted in a CLC90 revised edition to avoid false land use changes (Büttner and Maucha, 2006). Moreover, CORINE data also has a certain size for land use changes identification of 25 ha (Büttner *et al.*, 2002), so changes lower than this size was not identified. Other sources will be used to evaluate land use and land cover dynamics with larger temporal period at regional or national scale. This is the case of the 204 stands distributed in Iberian peninsula and Balearic islands of the SISPADES network, with dates 1956, 1984 and 1998 and a minimum patch size of 1 ha (Ortega *et al.*, 2008). In spite of the potential of this source, the CORINE data was selected due to it cover all territory. The model applied was a simple tool to integrate landscape changes with invariant driving forces. Other authors developed more sophisticated methods to include driving forces explicitly (*e.g.*, Hietel *et al.*, 2005). Although Markov chains do not have into account directly the drivers of land use change it assumes that these forces continue in the future (Briassoulis, 2000). The analysis served as an indicator of the direction and magnitude of change in the future if the driving forces continue in time, established from a quantitative description of change in the period evaluated. Some authors have indicated the restrictions of Markov chains in natural systems (Usher, 1979; Aaviksoo, 1995), such as the finite number of states of the system and discrete time. However, an example showed that Markov models are able to answer real questions (Feldman *et al.*, 2005), with a practical application for territory management, such as identification of the main changes and their possible greatest impacts in the near future. Markov chain models constitute a kind of distributional model, which are largely used because of their simplicity and utility (Baker, 1989).

Suitable land-use policies must assess and enhance the resilience of land uses in intensive land use regime (Foley *et al.*, 2005). The land use intensification in unprotected areas will affect to protected areas (Hansen

and de Fries, 2007). Then, achieve a sustainable land use dynamics in unprotected areas is one of the greatest challenges (Gómez-Sal, 1997; MMA, 2005). The methodology introduced is based on coarse filter theory (Hunter, 2005), that will be complementary to the species approach in territory conservation (Araujo *et al.*, 2007). Sustainable management of landscape requires this type of study (Romero-Calcerrada and Perry, 2004), and it will be applied to the identification of the main land use changes occurred inside and outside of protected areas. This application would serve as a base for the decision-making in the sustainable management (Kangas and Leskinen, 2005; Zavala and Burkey, 1997), considering that the simulations offered here serve to the identification of the main transition that had occurred in the territory and it would be desirable to stop. Other methodologies are available to simulate more realistic future trends through spatially explicit land use change models, reviewed in Briassoulis (2000) and Verburg *et al.* (2004), and different scenarios have been applied at European scale (*e.g.*, Verburg *et al.*, 2006). The methodology proposed can be useful for stakeholders and forest managers, in order to recognize the principal land use processes that affected cultural and traditional landscapes, and forest and semi-natural areas at different aggregations (first, second and third level of CORINE data). It constitutes a first order tool for decision making in the territory, following the criterion of policy and management dimensions (Niejemer and De Groot, 2008).

Acknowledgements

This research was supported by INTERBOS3-CGL2008-04503-C03-03 and SUM2008-00004-C03-01 project. P. Ruiz-Benito was supported by a FPU fellowship from the Spanish MEC (AP2008-01325). We are grateful to L. Gómez-Aparicio, C. Gonzalo Gómez and C. Fernández Aragón for her useful suggestions. Also, two anonymous reviewers provided helpful comments to improve the previous draft of this manuscript.

References

- AAVIKSOO K., 1995. Simulating vegetation dynamics and land use in a mire landscape using Markov model. *Landsc Urban Plan* 31, 129-142.
- ANTROP O.W., 2004. Landscape change and the urbanization process in Europe. *Landsc Urban Plan* 67, 9-26.
- ARAUJO M.B., LOBO J.M., MORENO J.C., 2007. The effectiveness of Iberian protected areas in conserving terrestrial biodiversity. *Conserv Biol* 21, 1423-1432.
- ASPINALL, R. 2004. Modelling land use change with generalized linear models – a multi-model analysis of change between 1860 and 2000 in Gallatin Valley, Montana. *J Environ Manage* 72, 91-103.
- BAKER W., 1989. A review of models of landscape change. *Landsc Ecol* 2, 111-133.
- BLONDEL J., 2006. The «design» of Mediterranean Landscapes: a millennial story of humans and ecological systems during the historic period. *Hum Ecol* 34, 713-729.
- BLONDEL J., ARONSON J., 1995. Biodiversity and ecosystem function in the Mediterranean basin: human and non-human determinants. In: *Mediterranean type ecosystem: the function of biodiversity* (Davis G.W., Richardson D.M., eds). Ed Springer-Verlag, Heilderberg, Germany. *Ecological Studies* 109. pp. 43-119.
- BOSSARD M., FENAREC J., OTAHEL J., 2000. CORINE Land Cover technical guide – Addendum 2000. Technical report No. 40. European Environmental Agency, Copenhagen, Denmark. 105 pp.
- BRIASSOULIS H., 2000. Analysis of land use change: theoretical and modeling approaches. *The Web Book of Regional Science*. Regional Research Institute, West Virginia University. Available on-line in <http://www.rri.wvu.edu/WebBook/Briassoulis/contents.htm> [10 June 2010].
- BROWN D.G., WALKER R., MANSON S., SETO K., 2004. Modeling land-use and land-cover change. In: *Land change science: observing, monitoring and understanding trajectories of change on the Earth's surface* (Gutman G., Janetos A.C., Justice C.O., Moran E.F., Mustard J.F., Rindfuss R.R., Skole D.L., Turner B.L., Cochrane M.A., eds). Ed Springer, New York, USA. pp. 395-409.
- BROOKS T.M., MITTERMEIER R.A., MITTERMEIER C.G., DA FONSECA G.A.B., RYLANDS A.B., KONSTANT W.R., FLICK P., PILGRIM J., OLDFIELD S., MAGIN G., HILTON-TAYLORS C., 2002. Habitat loss and extinction in the hotspots of biodiversity. *Conserv Biol* 16, 909-923.
- BUISSON E., DUITOIT T., 2006. Creation of the natural reserve of La Crau: implications for the creation and management of protected areas. *J Environ Manage* 80, 318-326.
- BÜTTNER G., FERANEC J., JAFFRAIN G., 2002. CORINE Land Cover update 2000. Technical report No. 89, European Environmental Agency, Copenhagen, Denmark. 56 pp.
- BÜTTNER G., MAUCHA G., 2006. The thematic accuracy of Corine Land Cover 2000. Assessment using LUCAS (land use/cover area frame statistical survey). Technical report No. 7. European Environmental Agency, Copenhagen, Denmark. 85 pp.
- CHAPE S., HARRISON J., SPALDING M., LYSENK I., 2005. Measuring extent and effectiveness of protected areas as indicator for meeting global biodiversity targets. *Phil Trans R Soc B* 360, 433-455.

- EEA, 2002. CORINE Land Cover update. I&CLC2000 project: technical guidelines. European Environmental Agency. 72 pp.
- EEA, 2007. CLC2006 technical guidelines. Technical report No. 17. European Environmental Agency, Copenhagen, Denmark. 66 pp.
- EEA, 2009. Nationally designated areas (National CDDA). Available on-line in <http://www.eea.europa.eu/data-and-maps/data/nationally-designated-areas-national-cdda-4> [10 June 2010].
- EUROPARC-ESPAÑA, 2007. Database updated 31th December 2007. Available on-line in http://www.redeuroparc.org/bases_datos.jsp [10 June 2010] [In Spanish].
- FELDMAN O.K., KOROTKOV V.N., LOGOFET D.O., 2005. The monoculture vs rotation strategies in forestry: formalization and prediction by means of Markov-chain modelling. *J Environ Manage* 77, 111-121.
- FOLEY J.A., DEFRIES R., ASNER G.P., BARFORD C., BONAN G., CARPENTER S.R., CHAPIN F.S., COE M.T., DAILY G.C., GIBBS H.K., HELKOWSKI J.H., HOLLOWAY T., HOWARD E.A., KUCCHARIC C.J., MONFREDA C., PATZ J.A., PRENTICE I.C., RAMANKUTTY N., SNYDER P.K., 2005. Global consequences of land use. *Science* 309, 570-574.
- GÓMEZ SAL, A., 1997. El paisaje agrario desde la perspectiva de la ecología. In: *Ciclo de agricultura y ecología*. Fundacion Bancaixa, Valencia, Spain. pp. 145-182. [In Spanish].
- GONZÁLEZ-BERNÁLDEZ F., 1991. Ecological consequences of the abandonment of traditional land use systems in central Spain. In: *Land abandonment and its role in conservation* (Baudry J., Bunce R.G.H., eds). *Options Méditerranéennes, Série Séminaires Méditerranéennes* 15. pp. 23-29.
- GULINCK H., MÚGICA M., DE LUCIO J.V., ATAURI J.A., 2001. A framework for comparative landscape analysis and evaluation based on land cover data, with an application in the Madrid region (Spain). *Landsc Urban Plan* 55, 257-270.
- HANSEN A.J., DE FRIES R., 2007. Ecological mechanisms linking protected areas to surrounding lands. *Ecol Appl* 17, 974-988.
- HATHOUT S., 2002. The use of GIS for monitoring and predicting urban growth in East and West St Paul, Winnipeg, Manitoba, Canada. *J Environ Manage* 66, 229-238.
- HEYWOOD V.H., DULLOO M.E., 2005. *In situ* conservation of wild plant species: a critical global review of best practices. Ed International Plant Genetic Resources Institute, Rome, Italy. IPGRI Technical Bulletin 11. 174 pp.
- HIETEL E., WALDHARDT R., OTTE A., 2005. Linking socio-economic factors, environment and land cover in the German Highlands, 1945-1999. *J Environ Manage* 75, 133-143.
- HOEKSTRA J.M., 2008. Advancing conservation in a globalized world. In: *Saving biological diversity: balancing protection of endangered species and ecosystems* (Askins R.A., Dreyer G.D., Visgilio G.R., Whitelaw D.M., eds). Ed Springer, New York, USA. pp. 203-212.
- HUNTER M.L., 2005. A mesofilter conservation strategy to complement fine and coarse filter. *Conserv Biol* 19, 1025-1029.
- IUCN, 1994. Guidelines for Protected Area Management Categories. Ed International Union for Conservation Nature and Natural Resources, Cambridge, UK and Gland, Switzerland. 261 pp.
- KADMON R., HARARI-KREMER R., 1999. Landscape scale regeneration dynamics of disturbed Mediterranean maquis. *J Veg Sci* 10, 393-402.
- KANGAS J., LESKINEN P., 2005. Modelling ecological expertise for forest planning calculations-rationale, examples, and pitfalls. *J Environ Manage* 76, 125-133.
- LAMBIN E.F., BAULIES X., BOCKSTAEL N., FISCHER G., KRUG T., LEEMANS R., MORAN E.F., RINDFUSS R.R., SATOY, SKOLE D., TURNER II B.L., VOGEL C., 1999. Land-Use and Land-Cover Change (LUCC): implementation strategy. IGBP Global Change Report 48, IHDP Report 10. 125 pp.
- MYERS N., MITTERMEIER R.A., MITTERMEIER C.G., DA FONSECA G.A.B., KENT J., 2000. Biodiversity hotspots for conservation priorities. *Nature* 403, 853-858.
- MARAÑÓN T., 1988. Agro-sylvo-pastoral systems in the Iberian peninsula: dehesas and montados. *Rangelands* 10, 255-258.
- MCKINNEY M.L., 2002. Urbanization, biodiversity and conservation. *BioScience* 52, 883-890.
- MMA, 2005. Estrategia Española para la conservación y el uso sostenible de la diversidad biológica. Ministerio de Medio Ambiente, Dirección General de Conservación de la Naturaleza, Madrid, Spain. 160 pp. [In Spanish].
- MORA M.R. (ed), 2003. Environmental connectivity. In: *Protected areas in the Mediterranean basin*. Autonomous Government of Andalusia, Sevilla, Spain. 196 pp. [In Spanish].
- NAVEH Z., 1987. Landscape ecology, management and conservation of European in Levant Mediterranean uplands. In: *Plant response to stress: functional analysis in Mediterranean ecosystems* (Tenhunen J.D., Catarino F.M., Lange O.L., Oechel W.C., eds). Ed Springer-Verlag, New York, Berlin, Heidelberg. pp. 641-657.
- NAVEH Z., 1971. The conservation of ecological diversity of Mediterranean ecosystem through ecological management. In: *The scientific management of animals and plant communities for conservation* (Duffley E., Watt A.S., eds). Proc Symp Brit Ecol Soc Norwich, Ed Blackwell Scientific Publications, London. pp. 605-622.
- NIEMEIJER D., DE GROOT R.S., 2008. A conceptual framework for selecting environmental indicator sets. *Ecol Indic* 8, 14-25.
- ORTEGA M., BUNCE R.G.H., GARCÍA DEL BARRIO J.M., ELENA-ROSELLÓ R., 2008. The relative dependence of Spanish landscape pattern on environmental and geographical variables over time. *Invest Agrar: Sist Recur For* 17, 114-129.
- OSE, 2006. Cambios en la ocupación del suelo en España. Implicaciones para la sostenibilidad. Observatory of Sustainability in Spain, Ministry of the Environment. Ed Mundi-Prensa, Madrid, Spain. 485 pp. [In Spanish].

- PARKER D., MANSON S., JANSSEN M., HOFFMANN M., DEADMAN P., 2003. Multi-agent systems for the simulation of land-use and land-cover change: a review. *Ann Assoc Am Geogr* 93, 314-337.
- PEÑA J., BONET A., BELLOT J., SÁNCHEZ J.R., EISENHUTH D., HALLETT S., ALEDO A., 2006. Driving Forces of Land-Use Change in a Cultural Landscape of Spain: A preliminary assessment of the human-mediated influences. In: *Modelling land use change: progress and applications* (Koomen E., Stillwell J., Bakema A., Scholten H., eds). Ed Springer, Dordrecht, The Netherlands. The *Geojournal Library* 90, 97-117.
- PETIT C.C., LAMBIN E.F., 2002. Long-term land-cover changes in the Belgian Ardennes (1975-1929): model based reconstruction vs. historical maps. *Glob Change Biol* 8, 616-630.
- ROBERTS F.S., 1976. Discrete mathematical models, with applications to social, biological, and environmental problems. Prentice-hall, in., New Jersey. 560 pp.
- RODRIGUES A.S.L., GASTON K.J., 2001. How large do reserve networks need to be? *Ecol Lett* 4, 602-609.
- ROMERO-CALCERRADA R., PERRY G.L.W., 2004. The role of land abandonment in landscape dynamics in the SPA «Encinares del Río Alberche y Cofio», Central Spain, 1984-1999. *Landsc Urban Plan* 66, 217-232.
- RUIZ-BENITO P., ZAVALA M.A., ÁLVAREZ-URÍA P. Protección de los hábitat por espacios naturales protegidos. In: *Sostenibilidad en España 2009*. Observatory of Sustainability in Spain, Ministry of the Environment, Ed Mundi-Prensa, Madrid, Spain. pp. 312-313. [In Spanish].
- STRAATMAN B., WHITE R., ENGELEN G., 2004. Towards an automatic calibration procedure for constrained cellular automata. *Comp Environ Urban Syst* 28, 149-170.
- TURNER M., 1987. Spatial simulation of landscape changes in Georgia: a comparison of 3 transition models. *Landsc Ecol* 1, 19-36.
- UNITED NATIONS, 1992. Convention on biological biodiversity. United Nations Environment Programme Na. 92-7807. Available on-line in <http://www.cbd.int/doc/legal/cbd-en.pdf> [10 June 2010].
- USHER M.B., 1979. Markovian Approaches to ecological succession. *J Anim Ecol* 48, 413-426.
- VERBURG P.H., SCHOT P.P., DIJST M.J., VELDKAMP A., 2004. Land use change modelling: current practices and research priorities. *GeoJournal* 61, 309-324.
- VERBURG P.H., SCHULP C.J.E., WITTE N., VELDKAMP A., 2006. Downscaling of land use chance scenarios to assess the dynamics of European landscapes. *Agric Ecosyst Environ* 114, 39-56.
- WASILEWSKI A., KRUKOWSKI K., 2004. Land conversion for suburban housing: a study of urbanization around Warsaw and Olsztyn, Poland. *Environ Manage* 34, 291-303.
- WENG Q., 2002. Land uses change analysis in the Zhujiang Delta of China using satellite remote sensing, GIS and stochastic modelling. *J Environ Manage* 64, 273-284.
- ZAVALA M.A., BURKEY T., 1997. Application of ecological models to landscape planning: the case of the Mediterranean basin. *Landsc Urban Plan* 38, 213-227.