

Tonic GABAergic inhibition as a new way to regulate mesolimbic dopamine system

Elena Vashchinkina

Institute of Biomedicine, Pharmacology
University of Helsinki

Academic Dissertation

To be presented with the permission of the Medical Faculty of the University
of Helsinki, for public examination in lecture hall 3, Biomedicum Helsinki 1,
Haartmaninkatu 8, on December 13th 2013
at 12 noon

Helsinki 2013

Supervisor

Professor Esa R. Korpi, MD PhD
Institute of Biomedicine, Pharmacology
Faculty of Medicine
University of Helsinki, Finland

Reviewers

Docent Mikko Airavaara, PhD
Institute of Biotechnology
University of Helsinki, Finland

Docent Tarja Stenberg, MD PhD
Institute of Biomedicine, Physiology
University of Helsinki, Finland

Dissertation Opponent

Professor Kimmo Jensen, MD PhD
Department of Biomedicine
Aarhus University, Denmark

ISBN 978-952-10-9636-5 (paperback)

ISBN 978-952-10-9637-2 (PDF)

<http://ethesis.helsinki.fi>

Unigrafia OY

Helsinki 2013

TABLE OF CONTENTS

Abstract	1
Original publications	2
Abbreviations	3
Glossary of terms	4
1 INTRODUCTION	5
2 REVIEW OF THE LITERATURE	7
2.1 The GABA_A receptor system	7
2.1.1 Diversity of inhibition through GABA _A receptors	8
2.1.2 GABA _A receptors underlying tonic currents.....	10
2.1.3 Origin of tonic currents.....	11
2.1.4 The mechanism of tonic inhibition	12
2.1.5 Modulators of extrasynaptic GABA _A receptors	13
2.1.6 Extrasynaptic GABA _A receptor as a potential drug target.....	17
2.2 The dopamine reward system	20
2.2.1 Neurophysiology of reward	21
2.2.2 Dopamine reward circuits	22
2.2.3 Afferent control of VTA neurons	22
2.2.4 Diversity of VTA neurons	24
2.2.5 Synaptic plasticity in VTA DA neurons	26
2.2.6 Drug-induced synaptic plasticity in VTA DA neurons	27
2.2.7 Modulation of dopamine system via GABAergic agents.....	29
3 AIMS OF THE STUDY	31
4 MATERIALS AND METHODS	33
4.1 Experimental animals	33
4.2 Electrophysiological studies	33
4.2.1 Acute midbrain VTA-slice preparation	34
4.2.2 Identification of the targeted neurons	34
4.2.3 Electrophysiological recordings and data analysis	34
4.3 Behavioral studies	34
4.3.1 Locomotor activity of mice.....	35
4.3.2 Light-dark choice test	35

4.3.2 Individual exploratory behavior.....	35
4.3.3 Place-conditioning for preference/aversion	35
4.3.4 Intravenous drug self-administration in mice	35
4.4 Immunohistochemical studies	36
4.4.1 c-Fos immunohistochemistry.....	36
4.5 Statistical tests	36
5 RESULTS AND DISCUSSION	39
5.1 THIP and GAN induced persistent LTP of LTP of glutamatergic synapses on VTA DA neurons.....	39
5.1.1 THIP and GAN increased AMPA/NMDA receptor-mediated current ratio in Th-EGFP mice	39
5.1.2 THIP and GAN were unable to induce glutamate neuroplasticity in δ -KO mice	41
5.1.3 Mechanism of THIP-induced glutamate neuroplasticity. Electrophysiological study	42
5.1.4 Tonic inhibition in VTA	43
5.1.5 Mechanism of GAN-induced glutamate neuroplasticity. Electrophysiological studies.....	44
5.2 Behavioral significance of the synaptic plasticity induced in the VTA	45
5.2.1 THIP exerted no reinforcement, but instead induced conditioned aversion in wild-type mice and baboons.....	46
5.2.2 GAN induced conditioned aversion in wild-type mice, but not in δ -KO mice	47
5.3 Mechanism of THIP-induced glutamate plasticity. The c-Fos study.....	48
5.4 Aversive THIP effects in abusers. Its limitations to treat primary insomnia	50
6 CONCLUSIONS	53
7 ACKNOWLEDGEMENTS	54
8 REFERENCES.....	56

ABSTRACT

Dopamine (DA) neurons of the ventral tegmental area (VTA) are critical for decision-making and motivation and have also been implicated in the development of addictive behaviors. The activity of these neurons and the subsequent changes in DA concentrations in the target regions of the VTA are strictly regulated by both excitatory and inhibitory inputs. Among those inhibitory inputs, GABAergic transmission is mediated by phasic and tonic currents generated through different GABA_A receptor subtypes. Although the phasic currents arising through the activation of synaptic GABA_A receptors have been well described, much less is known about extrasynaptic GABA_A receptors mediating tonic currents and modulating neuronal activity in the VTA.

Here, pharmacologically selective receptor modulators, transgenic mouse models and brain slice electrophysiology were all exploited to probe the role of extrasynaptic GABA_A receptors in mediating neuroplasticity in VTA DA neurons. Even though they possess distinct molecular sites of action, gaboxadol (THIP) and ganaxalone (GAN) enhanced tonic inhibition by selective targeting of the extrasynaptic δ subunit-containing GABA_A receptors located on VTA GABA neurons. The tonic inhibition induced in these neurons appeared to be sufficient to disinhibit DA neurons and induce persistent neuroplasticity in the glutamate synapses on VTA DA neurons, which resulted from insertion of new GluA2 subunit-lacking AMPA receptors into the synapses.

Screening of reward-related behaviors associated with VTA DA activity revealed that THIP failed to induce any reinforcement during self-administration either in mice or baboons. Moreover, both THIP and GAN produced conditioned place aversion in mice. The study performed in δ subunit-knockout mice further supported the proposal that tonic inhibition of the VTA GABA neurons contributes to conditioned aversive behavior and THIP- and GAN-induced neuroplasticity.

The c-Fos mapping of brain regions, which could take part in THIP-induced aversive behavioral effects and/or neuroplasticity on VTA DA neurons, revealed the bed nucleus of stria terminalis (BNST), a part of the so-called extended amygdala circuitry, as a possible participant in mediating the aforementioned THIP-induced aversive effects.

In summary, these studies demonstrate that tonic inhibition mediated by δ subunit-containing GABA_A receptors appears to be a significant component of the inhibition in the VTA, and thus important for the control of motivated behavior.

ORIGINAL PUBLICATIONS

This thesis is based on the following articles, referred to in text by their Roman numerals

- I. **Vashchinkina E**, Panhelainen A, Vekovischeva OY, Aitta-aho T, Ebert B, Ator NA, Korpi ER (2012) GABA site agonist gaboxadol induces addiction-predicting persistent changes in ventral tegmental area dopamine neurons but is not rewarding in mice or baboons. *J Neurosci* 32:5310-5320.

- II. **Vashchinkina E**, Manner AK, Vekovischeva OY, den Hollander B, Uusi-Oukari M, Aitta-aho T, Korpi ER (2013) Neurosteroid agonist at GABA_A receptor induces persistent neuroplasticity in VTA dopamine neurons. *Neuropsychopharmacology* (in press)

- III. **Vashchinkina E**, Vekovischeva OY, Panhelainen AE, Korpi ER. Impact of the extended amygdala on the anxiety-like effects of the GABA agonist gaboxadol. Submitted manuscript

ABBREVIATIONS

AMPA	α -amino-3-hydroxy-5-methyl-4-isoxazolepropionic acid
AA29504	2-amino-4-(2,4,6-trimethylbenzylamino)-phenyl-carbamic acid ethyl ester
BBB	Blood brain barrier
BNST	Bed nucleus of stria terminalis
BLA	Basolateral complex of the amygdala
CA1	Cornu ammonis 1 of the hippocampus
CA3	Cornu ammonis 3 of the hippocampus
CeA	Central nucleus of the amygdala
c-Fos	Cellular oncogene Fos
DA	Dopamine
D-AP5	D-2-amino-5-phosphonopentanoic acid; NMDA receptor antagonist
δ -KO	GABA _A receptor δ -subunit knockout mouse line
δ -WT	GABA _A receptor δ -subunit wild type mouse line
DS1	4-chloro-N-[6,8-dibromo-2-(2-thienyl) imidazo [1,2-a] pyridine-3-yl] benzamide
DS2	4-chloro-N-[2-(2-thienyl) imidazo [1,2-a] pyridine-3-yl] benzamide
JM-11-43A	Dihydropyrimidinone
EGFP	Enhanced green fluorescent protein
EPSC	Excitatory postsynaptic current
GABA _A	γ -aminobutyric acid type A (receptor)
GAN	3 α -hydroxy-3 β -methyl-5 α -pregnan-20-one, ganaxolone
IPSC	Inhibitory postsynaptic current
LDT	Laterodorsal tegmentum
LTD	Long-term depression
LTP	Long-term potentiation
mEPSC	Miniature excitatory postsynaptic current
NAcc	Nucleus accumbens
NMDA	N-methyl-D-aspartate
PFC	Prefrontal cortex
RMTg	Rostromedial tegmental nucleus
PVA	Paraventricular thalamic nucleus
sIPSC	Spontaneous inhibitory postsynaptic current
Th	Tyrosine hydroxylase
THIP	4,5,6,7-tetrahydroisoxazolo(5,4-c)pyridin-3-ol, gaboxadol
VTA	Ventral tegmental area
vPAG	Ventrolateral periaqueductal grey
5 α -THDOC	5 α -tetrahydrodeoxycorticosterone
5 α 3 α -THPROG	5 α 3 α -tetrahydroprogesterone, allopregnanolone

GLOSSARY OF TERMS

Phasic GABAergic transmission refers to synaptic-type of neuronal transmission generated by the rapid, transient activation of synaptic ionotropic GABA_A receptors by presynaptic GABA release. The phasic transmission is present in all brain areas, and mediates most of the fast-acting inhibitory neurotransmission.

Tonic GABAergic transmission refers to the nonsynaptic-type of neuronal transmission generated by the persistent activation of specialized classes of ionotropic GABA_A receptors residing outside of the synaptic cleft. These “extrasynaptic” GABA_A receptors can detect low ambient GABA levels. Tonic transmission is present only in selected brain regions, especially in the cerebellum and thalamus, and it participates in controlling neuronal excitability.

Phasic DAergic transmission refers to the burst spike firing pattern, which often occurs in response to behaviorally relevant stimuli. This burst spike activity triggers a high amplitude (μM to mM levels), transient phasic DA release within the target areas.

Tonic DAergic transmission refers to constantly occurring baseline firing, which is driven by pacemaker-like membrane currents of DA neurons. Tonic activity keeps up extracellular baseline DA levels (nM levels) within the target areas.

1 INTRODUCTION

We are continually bombarded by different stimuli, theoretically, all could be acted upon, but in fact only a few become the targets of behavior. The mesolimbic dopamine (DA) system is one of the brain systems whose function is to alert the organism and help it to “prioritize” one stimulus over another to support its well-being and adjustment to the environment. Drug addiction is a chronic disorder associated with loss of control over drug seeking and drug intake. Drugs of abuse converge on the DA system to change the rules by “re-prioritizing” drug-associated stimuli so that they even are placed ahead of those essential for survival.

Once the effects of drugs of abuse have been experienced, they induce long-term synaptic plasticity in the excitatory transmission in midbrain DA neurons in ventral tegmental area (VTA). Although these adaptations are transient, they are believed to reflect “memory trace” left by drugs of abuse after they have disappeared from the brain, and can lead to a rearrangement of neural circuitry involving many other neuromodulator systems.

Stringent control of VTA activity by the main brain inhibitory neurotransmitter system, using γ -aminobutyric acid (GABA) as the transmitter, ensures its normal functioning. The other side of the coin is that, the DA system also becomes a target for many GABAergic drugs. Indeed, benzodiazepines, anesthetics and alcohol all selectively or less selectively act on GABA type A (GABA_A) receptors. It is well known that the long-term use of these drugs and alcohol may result in the development of addiction, tolerance and dependence.

According to the latest European reports, 15.5 million people suffer from drug and alcohol addiction and the total cost related to this disorder exceeded over 60 billion euros (Olesen et al., 2012). Thus, the physiological and pharmacological consequences of addictive drug use are of major research interest. This serves us the impetus for the extensive research efforts being made to seek for new drugs which

would possess more selective actions with greater efficacy and fewer side effects. Extrasynaptic GABA_A receptors can be considered as a potent new therapeutical target for several central nervous system (CNS) disorders. These special types of inhibitory receptors are expressed at relatively low levels throughout the brain in selected populations of neurons, and it is known that they can be selectively modulated by pharmacological agents.

The present study explored the modulation of activity of VTA DA neurons and synaptic plasticity by selective modulators of extrasynaptic GABA_A receptors. Then the significance of synaptic adaptations induced by these compounds was evaluated in several reward-related tasks and models to reveal their possible addictive or anti-addictive properties.

2 REVIEW OF THE LITERATURE

2.1 THE GABA_A RECEPTOR SYSTEM

γ -Aminobutyric acid (GABA) is the main inhibitory neurotransmitter in the brain. This neurotransmitter exerts its actions by interacting with specialized membrane proteins, the GABA receptors. The fast-acting inhibitory effects of GABA are performed by GABA_A receptors (Naik et al., 1976).

GABA_A receptors belong to the “cys-loop” superfamily of ligand-gated ion channels (Leite and Cascio, 2001). They exist as heteropentameric structures where five subunits are arranged around a central pore. When GABA (the endogenous ligand of GABA_A receptor) binds to and triggers conformational change in the receptor complex, this leads to opening of the pore. This, in turn, allows Cl⁻ and HCO₃⁻ ions to pass down their electrochemical gradients, and induce hyperpolarization of cell. This hyperpolarization creates an inhibitory effect on neurotransmission by decreasing the probability of generating an action potential. In some instances, e.g. in early neuronal development, they can be depolarizing because the intracellular Cl⁻ concentration is high (Kaila et al., 1997; Rivera et al., 1999). Thus, depolarization creates an excitatory effect on neuronal neurotransmission.

GABA_A receptors display widespread expression in all brain regions (Lüddens and Korpi, 1995), but they exhibit unique heterogeneity in terms of structure, function, distribution, and pharmacological profile (Uusi-Oukari and Korpi, 2010). This heterogeneity results from the large number of subunits, which can be present in a GABA_A receptor. To date, 19 subunits have been cloned (Barnard et al., 1998).

According to an analysis of the homology, they can be subdivided into 8 classes: α 1-6, β 1-3, γ 1-3, δ , ϵ , θ , π , ρ 1-3 (Olsen and Sieghart, 2009). Additional heterogeneity occurs via alternative splicing of exons during gene expression (Kirkness and Fraser, 1993; Korpi et al., 1994; Jin et al., 2004).

It is noteworthy to mention that a comparative analysis of the GABA_A receptor genes between the species has not revealed any new GABA_A receptor subunits in the human genome (Simon et al., 2004). Accordingly, the human the GABA_A receptor genes show a basic pattern of 9 coding exons. Additional noncoding exons have been discovered for certain subunits, and these may exert regulatory functions (Simon et al., 2004). This kind of high level of GABA_A receptor homology makes research in rodents highly translatable to the human condition, which can be important in drug discovery in the GABA_A receptor field.

The GABA_A receptor is usually composed of two α subunits, two β subunits and one γ or δ subunit (McKernan and Whiting, 1996). If one considers the γ -containing receptors, then α 1 β 2 γ 2, α 2 β 2/3 γ 2 and α 3 β γ 2/ γ 3 are the most abundant combinations. They are present in almost all brain areas, and together they constitute about 75 % of the total GABA_A receptor repertoire (Fritschy et al., 1992; Laurie et al., 1992). As a general rule, γ -containing receptors are preferentially located into synapses (Fritschy et al., 1992; Peng et al., 2002). Other subtypes consist of mainly α 4 β δ and α 6 β δ compositions. These exhibit a more selective distribution in brain, but they account for only 5% of total receptor repertoire and exclusively located out of synapse. Despite the low abundance of δ -containing receptors, they exert a major impact on the functioning of neuronal network.

2.1.1 Diversity of inhibition through GABA_A receptors

The GABAergic cells regulate the activity of neuronal networks by acting through diverse sets of inhibitory processes, the complexity of which is supplemented by the wide variety of interneurons and their circuits (Klausberger and Somogyi, 2008). Moreover, the intrinsic properties of GABA_A receptors and their subcellular localization can develop several forms of inhibition (Mody and Pearce, 2004).

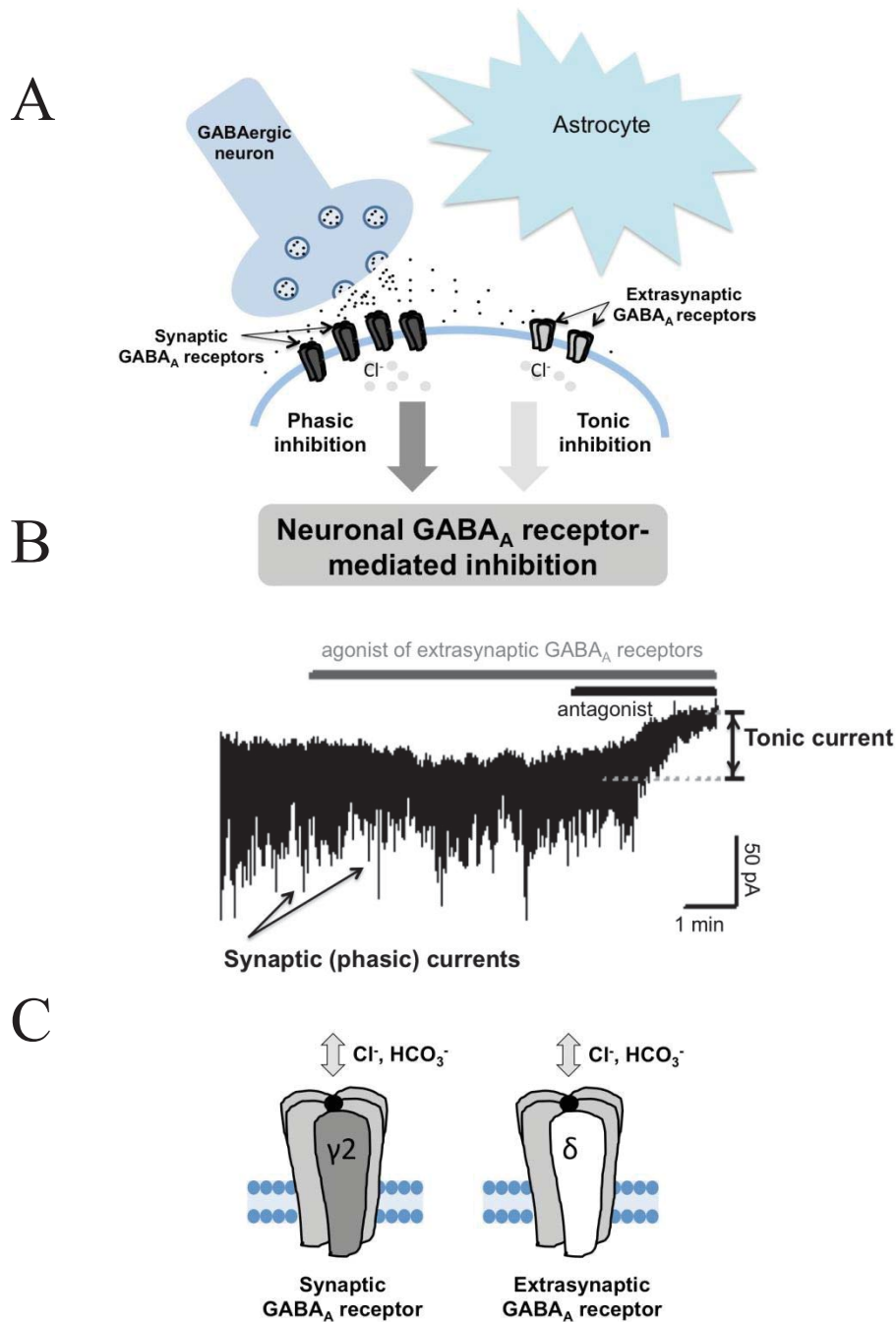

Figure 1. Neuronal inhibition mediated via GABA_A receptors contains phasic and tonic components.

A. Neurotransmitter GABA, after release from GABAergic interneuron, binds to and activates synaptic and extrasynaptic GABA_A receptors promoting phasic and tonic components of inhibition, respectively. The astrocytes are involved in several processes including GABA uptake and release, regulation of anion concentration in the extracellular space. **B.** Whole-cell patch-clamp recording of GABA_A receptor-mediated currents shows phasic and tonic currents. Phasic current is represented by the phasic inward inhibitory post-synaptic currents (IPSCs). It can be inhibited by treatment with a GABA_A receptor antagonist (e.g. gabazine). The antagonist also blocks the tonic current, which results in an outward shift of the holding current. **C.** GABA_A receptors contain 5 membrane-crossing subunits that are arranged to form an intrinsic anion-conducting channel. Most synaptic receptors comprise α , β and $\gamma 2$, whereas extrasynaptic comprise α , β and δ subunits.

The two main forms of inhibition are mediated by GABA_A receptors (*Figure 1A*). Phasic (also called synaptic) inhibition is generated by “phasic” inhibitory post-synaptic currents (IPSCs) following activation of γ -containing GABA_A receptors (Farrant and Nusser, 2005). In contrast to phasic IPSCs, tonic inhibition results from a persistent low-amplitude current capable of additional modulation of action potential firing (*Figure 1B*) (Walker and Kullmann, 2012).

Tonic inhibition results from activation of δ -containing GABA_A receptors which are located outside of synapses. The hallmarks of extrasynaptic and perisynaptic GABA_A receptors are their high affinity for GABA and slow desensitization (*Figure 1C*) (Farrant and Nusser, 2005), but also see (Bright et al., 2011). These extrasynaptic δ -containing GABA_A receptors will be the central topic of this thesis.

2.1.2 GABA_A receptors underlying tonic currents

Extrasynaptic GABA_A receptors mediating tonic currents are different from those contributing to the peak synaptic currents (*Table 1*). They are developmentally regulated and exhibit a cell-type specific distribution (Farrant and Nusser, 2005; Walker and Kullmann, 2012).

Cerebellar granule cells probably are the best example of a brain region expressing large numbers of GABA_A receptors contributing to tonic inhibition (Kaneda et al., 1995). Lately, tonic inhibition also has been found in the hippocampal CA1 interneurons (Semyanov et al., 2003), granule cells of the dentate gyrus (Nusser and Mody, 2002), interneurons of the dentate molecular layer (Glykys et al., 2007), thalamocortical relay neurons (Porcello et al., 2003), pyramidal cells in the neocortex (Vardya et al., 2008), basolateral (BLA) and lateral (LA) nuclei of the amygdala (Marowsky et al., 2012).

Several GABA_A receptor subtypes have been proposed to mediate tonic inhibition. In particular, $\alpha 6\beta\gamma\delta$ mediate tonic currents in cerebellar granule cells (Brickley et al., 1996), $\alpha 1\beta\gamma\delta$ receptors in hippocampal interneurons (Glykys et al., 2007), $\alpha 4\beta\gamma\delta$ receptors in dentate granule cells (Nusser and Mody, 2002), and thalamocortical neurons (Belelli et al., 2005). Other receptor subtypes may also

mediate tonic currents, including the ϵ -containing receptors in hypothalamic neurons (Wagner et al., 2005) and $\alpha 5\beta\gamma\chi$ receptors in CA1 pyramidal cells (Caraiscos et al., 2004). Nonetheless $\alpha 5\beta\gamma\chi$ receptors in contrast to the δ -containing receptors have a very restricted distribution within hippocampus, and they are not exclusively located extrasynaptically (Serwanski et al., 2006).

There is growing evidence that other GABA_A receptors can be expressed extrasynaptically and are able to mediate a tonic current (Mody and Pearce, 2004; Walker and Kullmann, 2012). Even within a single neuron there may be several subtypes exhibiting different subunits and consequently receptors with different affinities for GABA may contribute to the generation of tonic current (Prenosil et al., 2006). This heterogeneity might be needed to extend the range of extracellular GABA concentrations that can modulate neuronal excitability and increase the number of potential modulators (Walker and Kullmann, 2012).

Table 1. Hallmarks of synaptic and extrasynaptic GABA_A receptors Modified from (Reddy, 2013).

Synaptic GABA_A receptor	Extrasynaptic GABA_A receptor
Mediation of phasic currents	Mediation of tonic currents
Pentameric ligand-gated anion channels	Pentameric ligand-gated anion channels
Presence of $\gamma 2$ subunit	Presence of δ , $\alpha 5$ subunits
Synaptic localization	Perisynaptic, extrasynaptic localization
Low GABA affinity	High GABA affinity
Not blocked by low Zn ²⁺	Blocked by low Zn ²⁺
Wide distribution in the brain	Selective distribution in brain region

2.1.3 Origin of tonic currents

In evolutionary terms, GABA signaling was already found in invertebrates and bacteria (Lummis et al., 1991; Belelli et al., 1996). Subsequently sequence analysis has revealed that this system has been conserved throughout the course of evolution (Martyniuk et al., 2007; Ryan and Grant, 2009). Interestingly, it is even possible that GABA receptors preceded the origin of synapses and excitatory ionotropic glutamate receptors (Perovic et al., 1999; Ryan and Grant, 2009).

The gene coding the δ subunit is positioned separately from the rest of subunits on chromosome 4 and 1 (1p36.3) in mice and humans, respectively (Sommer et al., 1990; Windpassinger et al., 2002). The phylogenetic studies of Ortells and Lunt

suggested that δ subunit is the most primitive subunit within GABA_A receptor family (Ortells and Lunt, 1995). In line with this view, pharmacological studies in primitive invertebrates (e.g. *Hydra Vulgaris*) with the simplest nervous system have revealed that they possess GABA_A receptors which are sensitive to muscimol and neurosteroids, modulators of extrasynaptic receptors (Concas et al., 1998). It is believed that these early developmental forms of GABA signaling may play a role in controlling of feeding, as well as participating in the neuronal differentiation (LoTurco et al., 1995; Concas et al., 1998; Brickley and Mody, 2012).

2.1.4 The mechanism of tonic inhibition

The tonic inhibition (or excitation) remains as a form of signaling which is not time-locked to presynaptic action potentials. Thus, the tonic signaling profoundly modulates the input-output relationships of the neurons. Notably, tonic currents can sometimes be paradoxically excitatory, either by depolarizing neurons or via a network effect (Walker and Kullmann, 2012).

The mechanism of tonic inhibition needs to be clarified even though numerous studies have tried to address this issue. There are three hypotheses which have been proposed to explain this action:

1. Tonic inhibition results from summation of overlapping miniature IPSCs (Salin and Prince, 1996). Demonstration of distinct pharmacological properties of tonic current and miniature IPSCs has rejected this hypothesis. In particular, in hippocampal cells the GABA_A receptor antagonist, gabazine, blocked miniature IPSCs, but not tonic current (Bai et al., 2001).

2. Tonic inhibition results from activation of high-affinity extrasynaptic GABA_A receptors by GABA, which may have spilled-over from neighboring synapses (Brickley et al., 1996; Rossi et al., 2003). A recent re-examination challenged this assumption and proposed that spillover and tonic currents are separate phenomena, reflecting the activation of distinct GABA_A receptor populations in thalamus and cerebellum (Bright et al., 2011). Indeed, the source of ambient GABA can have a different origin depending on cell type, anatomy of synapse etc. It has been suggested to originate from astrocytes (Liu et al., 2000), reversed transport of GABA

by its transporter (Gasparly et al., 1998; Wu et al., 2006), by a reduced activity of GABA-transaminase (Overstreet and Westbrook, 2001), by non-vesicular GABA exocytosis (Rossi et al., 2003), as well as from glial cells by permeation through the Bestrophin 1 anion channel (Lee et al., 2010).

3. Tonic inhibition results from spontaneously opening GABA_A channels (Birnie et al., 2000; Birnie et al., 2000). In other words, the authors hypothesized that there is neurotransmitter-independent mechanism of tonic inhibition in hippocampal CA1. However, this hypothesis does not explain several issues. First, concentration-dependent enhancement of tonic current was observed in response to GABA (Overstreet and Westbrook, 2001). Second, this hypothesis also is at odds with the well-known observation that GABA_A receptor antagonists, which compete with GABA for the same binding site, block tonic inhibition (Mody and Pearce, 2004; Farrant and Nusser, 2005). Moreover, these antagonists could exert an intrinsic effect without competing with GABA (Korpi et al., 1996). All these aforementioned findings seem to indicate that the tonic current may consist of two components: neurotransmitter GABA-dependent and GABA-independent currents.

2.1.5 Modulators of extrasynaptic GABA_A receptors

Several mechanisms have been postulated to modulate tonic inhibition, e.g. alterations in receptor expression, changes in endogenous neurosteroids, variations in ambient GABA concentrations, and numerous neuroactive drugs (Walker and Kullmann, 2012).

▪ Endogeneous modulators of extrasynaptic GABA_A receptors

In addition to the natural neurotransmitter GABA, endogenous neurosteroids and their metabolites such as 5 α -tetrahydrodeoxycorticosterone (5 α -THDOC) and 5 α 3 α -tetrahydroprogesterone (5 α 3 α -THPROG, also known as allopregnanolone) are the most potent positive modulators of GABA_A receptors (Lambert et al., 2009). Neurosteroids are synthesized *de novo* by some neurons and glia (Robel et al., 1995; Melcangi et al., 2001). They act on the GABA_A receptor at distinct sites not overlapping with the binding sites of GABA, benzodiazepines, or barbiturates (Gee et al., 1995). Moreover, neurosteroids display broad-spectrum modulatory effects on

several GABA_A receptors (Lambert et al., 2009), they exhibit particular sensitivity to extrasynaptic $\alpha 4\beta\delta$, $\alpha 6\beta\delta$ receptors (Wohlfarth et al., 2002; Spigelman et al., 2003). Furthermore, their effects on GABA_A receptors have been postulated to involve signaling via protein kinase C activity (Fancsik et al., 2000), and to influence GABA_A receptor subunit expression (Shen et al., 2005; Maguire et al., 2005; Maguire and Mody, 2007). Administration of neurosteroids evokes anxiolytic, sedative, analgesic, and anticonvulsive effects (Lambert et al., 2009).

▪ **Exogenous modulators of extrasynaptic GABA_A receptors**

Direct GABA_{mimetic agent} muscimol, is a psychoactive ingredient of the mushroom *Amanita muscaria*, activates all GABA_A receptors by targeting binding site of GABA (*Figure 2*) (Krogsgaard-Larsen et al., 1979; Korpi et al., 2002). Recently, electrophysiological studies with recombinant GABA_A receptors and high-affinity [3H]muscimol binding have revealed that muscimol has a preferential action on $\alpha 4\beta 3\delta$ and $\alpha 6\beta\delta$ extrasynaptic GABA_A receptors (Storustovu and Ebert, 2006; Chandra et al., 2010). Despite the fact that muscimol has been extensively studied over decades, its poor blood brain barrier (BBB) penetration property did not allow its use in clinic (Krogsgaard-Larsen et al., 2004).

THIP (4,5,6,7-tetrahydroisoxazolo(5,4-c)pyridin-3-ol, also known as gaboxadol) is a muscimol analogue with better bioavailability (*Figure 2*) (Krogsgaard-Larsen et al., 1979; Brown et al., 2002; Storustovu and Ebert, 2006). THIP acts as a partial agonist at the synaptic $\alpha 1$ -containing receptors, full agonist at $\alpha 2$ -containing receptors, and as a superagonist at the extrasynaptic GABA_A receptors (Ebert et al., 1994; Ebert et al., 1997; Wafford and Ebert, 2006). Indeed, THIP exhibits a 10-fold higher potency for the $\alpha 4\beta 3\delta$ and $\alpha 6\beta 3\delta$ than for synaptic receptors. Moreover, THIP induces a tonic current via these δ receptors which is double that which can be achieved by GABA (Brown et al., 2002; Saarelainen et al., 2008; Meera et al., 2011), and GABA can act as an antagonist by reducing these “superagonist” THIP-effects.

THIP appears mainly to exert its action in the midbrain and forebrain (Krogsgaard-Larsen et al., 2004). Its administration leads to sedative, analgesic and ataxic effects, which were completely abolished in mice lacking either $\alpha 4$ or δ subunits (Chandra et al., 2006; Winsky-Sommerer et al., 2007). There are several reports demonstrating

that at therapeutical relevant concentrations THIP preferentially acts at extrasynaptic receptors, whereas higher concentrations can affect additional subtypes (Boehm et al., 2006). THIP displayed low tolerance and addiction properties in clinical trials for its hypnotic effects (Ebert et al., 2006). However, it was discontinued due to lack of efficacy and a higher incidence of psychiatric side effects (see website downloaded in November 2013 <http://www.drugs.com/news/merck-amp-co-inc-lundbeck-discontinue-joint-development-program-gaboxadol-investigational-compound-5660.html>).

DS1 and DS2 compounds from the imidazopyridine family have been recently described (Wafford et al., 2009). For example, DS1 is considered to be selective agonist of δ -containing GABA_A receptors, whereas DS2 is an allosteric enhancer of receptor function (Wafford et al., 2009). Importantly, the binding sites for these compounds are distinct from currently known sites on GABA_A receptor (Wafford et al., 2009; Jensen et al., 2013). The current data originate mainly from in vitro experiments, as in vivo studies have been complicated so far because of the very poor brain penetration of these analogs (Jensen et al., 2013).

Synthetic neurosteroid ganaxolone (3 α -hydroxy-3 β -methyl-5 α -pregnan-20-one) is the 3 β -methylated synthetic analog of allopregnanolone, which exhibits potent anticonvulsant activities (*Figure 2*) (Carter et al., 1997; Reddy and Rogawski, 2009). Since ganaxolone shares the primary neuropharmacological characteristics of allopregnanolone (Belelli and Herd, 2003), in this chapter its distinct features will be reviewed. First, ganaxolone lacks nuclear steroid hormonal activity, and therefore does not exert steroidal side effects (Carter et al., 1997). Second, ganaxolone preferentially acts on δ -containing GABA_A, then on α 1, α 2 or α 3-containing GABA_A receptors (Carter et al., 1997; Mihalek et al., 1999; Belelli et al., 2005; Brown et al., 2002; Fodor et al., 2005). Third, ganaxolone has a rapid onset of action and it is quickly metabolized (Nohria and Giller, 2007). Fourth, ganaxolone acting on δ -containing GABA_A receptors exerts anxiolytic and anticonvulsive and anesthetic effects in mice (Mihalek et al., 1999).

Triaminobenzene compound AA29504 (2-amino-4-(2,4,6-trimethylbenzyl amino) - phenyl-carbamic acid ethyl ester) has been recently described as a functionally positive allosteric modulator of the effects of agonists (GABA and THIP) for $\alpha 4\beta 3\delta$ GABA_A receptors. AA29504, over a range of doses, has been reported to penetrate readily through the BBB, and its administration results in stress-reducing and anxiolytic effects in mice (Hoestgaard-Jensen et al., 2010; Vardya et al., 2012). On other hand, AA29504 is an analogue of retigabine, the Kv7 channel opener. Therefore, the effects of AA29504 need to be carefully reviewed if one is associating its actions exclusively with δ -containing GABA_A receptors (Hoestgaard-Jensen et al., 2010; Vardya et al., 2012).

Dihydropyrimidinone compound JM-11-43A has been described as a selective positive allosteric modulator of $\alpha 4\beta 3\delta$ GABA_A receptors, but as with AA29504 this drug appears to exhibit only limited selectivity (Lewis et al., 2010).

Ethanol acts widely on many types of ion channels and intracellular signalling pathways including GABAergic system. Extrasynaptic GABA_A receptors also seem to agree with this rule (Uusi-Oukari and Korpi, 2010). Several studies have shown that low concentrations of ethanol enhance tonic current (Smith et al., 1992; Wallner et al., 2003; Hancher et al., 2004). On the other hand, deletion of the $\alpha 4$ subunit did not result in any changes in behavior after acute effects on ethanol (Chandra et al., 2008), and several groups have failed to detect the low concentration effects of ethanol on δ -containing GABA_A receptors (Borghese et al., 2006; Korpi et al., 2007; Linden et al., 2011).

Several general anesthetics (isoflurane, etomidate) display broad-spectrum modulatory effects on several GABA_A receptors, but isoflurane and etomidate exhibit a more selective action on extrasynaptic GABA_A receptors. In particular, volatile anesthetic isoflurane, at its low sedative concentrations (25-85 mM), selectively increases tonic conductance targeting extrasynaptic $\alpha 5\beta 3\gamma 2L$ in the hippocampus (Caraiscos et al., 2004) and $\alpha 4\beta 2\delta$ GABA_A receptors in the thalamus (Chandra et al., 2006; Jia et al., 2009). Similar to isoflurane, the intravenous anesthetic, etomidate, is known to enhance tonic conductance by targeting $\alpha 4\beta 2/3\delta$ in the neocortex (Brown et al., 2002; Drasbek et al., 2007).

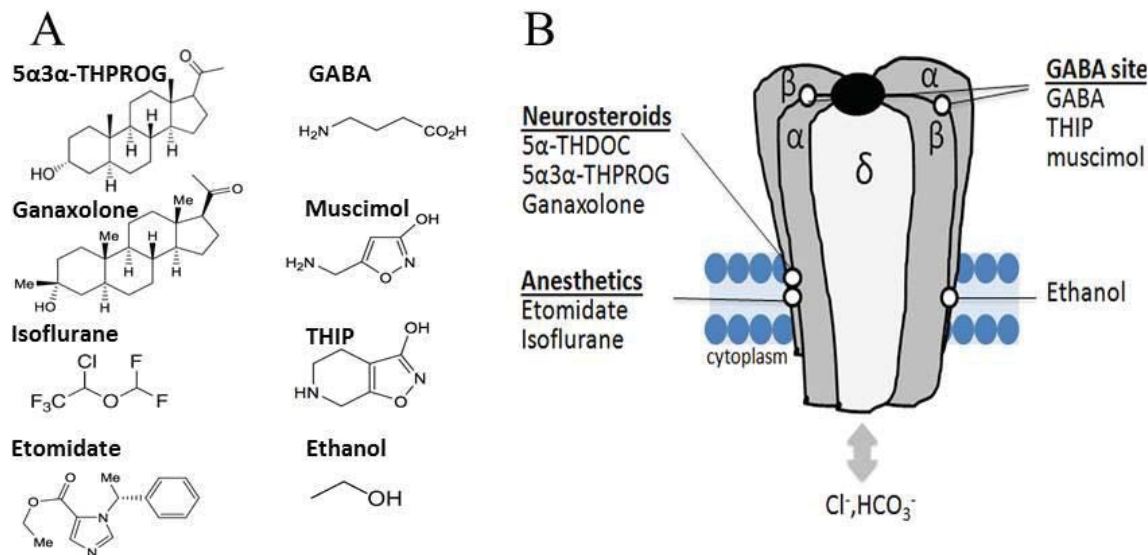

Figure 2. Schematic representation of the δ -containing GABA_A receptor and its associated binding sites for its modulators.

The extrasynaptic GABA_A receptors contain binding sites for several clinically relevant drugs. **A.** Chemical structures for modulators of the receptor **B.** GABA-mimetic drugs bind to the two GABA-sites at the interface between α and β subunits. Anesthetics, neurosteroids, and ethanol bind to distinct sites in the membrane-spanning transmembrane regions at the interface between α and β subunits. The binding sites for DS1, DS2, AA29504, and JM-11-43A have not been identified.

2.1.6 Extrasynaptic GABA_A receptor as a potential drug target

From the therapeutic perspective, extrasynaptic GABA_A receptors are considered as a potentially important pharmacological target for several central nervous system (CNS)-, and non-CNS-related disorders (Table 2) (Mendu et al., 2011; Brickley and Mody, 2012).

To date, several compounds including THIP and GAN are undergoing clinical trials. In particular, the combination of THIP and escitalopram, a selective serotonin reuptake inhibitor, was recently tested in a clinical trial (Phase II) for the treatment of patients with severe major depressive disorder. Regrettably, after 8 week-treatment there was no clinically relevant efficacy difference between a combination of escitalopram and THIP compared to escitalopram alone (Kasper et al., 2012).

Several clinical trials (Phase II) of ganaxolone have been completed for the treatment of epilepsy in both infants and adults (Nohria and Giller, 2007; Pieribone et al., 2007). In addition, there are several ongoing trials (all in Phase II) for the treatment fragile X syndrome, posttraumatic stress disorder, and nicotine dependence (see website downloaded in November 2013 www.clinicaltrials.gov).

Table 2. Summary of the implications of extrasynaptic GABA_A receptors in human disorders

Implications	Findings	References
Adult uncontrolled partial-onset seizures, catamenial epilepsy, infantile spasms	Deficient of tonic inhibition due to several reasons including mutations in the δ subunit gene, imbalance of neurosteroids	Mihalek et al., 1999; Maguire et al., 2005; Biagini et al., 2010; Macdonald et al., 2010
Absence epilepsy	Enhancement of tonic inhibition on thalamic relay neurons	Fariello and Golden, 1987
Pain (acute nociception and central sensitization)	Deficient of tonic inhibition in lamina II neurons in spinal cord	Peng et al., 2009; Bonin et al., 2011
Post- traumatic stress disorder	Deficient of tonic inhibition in hippocampus. Decrease in the allopregnanolone levels in medial prefrontal cortex, hippocampus, and basolateral amygdala	Wiltgen et al., 2005; Pibiri et al., 2008
Schizophrenia	Disbalance of neurosteroids: increased pregnenolone and dehydroepiandrosterone levels in posterior cingulate and parietal cortex, reduced allopregnanolone levels in parietal cortex	Marx et al., 2006
Mood disorders (major depressive disorder, female stress disorders, childhood-onset mood disorders)	Imbalance of GABAergic signaling. Chromosomal 1p36 deletion (or dysfunction) associated with moderate to severe psychomotor retardation, epilepsy, and self-abusive behaviour resulting in chromosomal deletion the δ subunit of the human GABA _A receptors	Windpassinger et al., 2002; Maguire and Mody, 2007; Smith et al., 2007; Feng et al., 2010
Alcoholism	Disbalance of GABAergic signaling associated with elevation of endogenous neurosteroids, presynaptic release of GABA, and dephosphorylation of GABA _A receptors. Reduction of δ subunit in medial shell region of the NAcc reduces alcohol intake	Enoch, 2008; Rewal et al., 2009; Nie et al., 2011

Fragile X syndrome	Impaired GABAergic transmission in different brain regions in Fmr1 knockout mice. Deficits in tonic inhibition might be responsible for hypersensitivity to auditory stimuli, hyperactivity, exaggerated fear, and seizures	Olmos-Serrano et al., 2010; 2011 Heulens et al., 2012; Conde et al., 2013
Learning and memory enhancement	Partial or full deficiency of $\alpha 5$, and also that of δ subunit improved performance in associative learning and memory tasks. Enhanced tonic inhibition attenuates development of LTP in hippocampus	Collinson et al., 2002; Yee et al., 2004; Shen et al., 2010
Neuroprotection	Reduction $\alpha 5$ - and δ -mediated tonic inhibition promotes functional recovery after stroke	Clarkson et al., 2010; Santhakumar et al., 2010
Type 1 diabetes	Potential role of δ -containing GABA _A receptors in the decrease of pancreatic islet inflammation by inhibiting autoreactive T cells	Mendu et al., 2011; Jin et al., 2013

2.2 THE DOPAMINE REWARD SYSTEM

In 1954, James Olds and Peter Milner of McGill University first described rewarding and aversive nuclei in the septal area, when stimulation of those made “rats do everything possible to meet or avoid stimulation”, respectively (Olds and Milner, 1954). Further pharmacological experiments on intracranial self-administration of different drugs of abuse within the above brain regions just supported the idea of a reward circuit (Wise and Bozarth, 1985; Carlezon and Wise 1996).

Later, Phillips and Fibiger revealed the crucial role of dopamine (DA) in maintaining self-stimulation in the ventral tegmentum, nucleus accumbens (NAcc), and medial prefrontal cortex (Phillips and Fibiger, 1978; Grace, 1991). In the 1990’s, it was found that a phasic DA release (transient strong release of DA by action potentials burst firing in DA neurons) was associated with different rewarding events (Grace, 1991; Schultz et al., 1997). Today, the development of novel state-of-the-art techniques (genetic mouse models, novel tracers, optogenetics, etc.) has expanded our knowledge by clarifying the neural pathways involved in the processing of reward and aversion (Luscher and Malenka, 2011; Jennings et al., 2013; Lammel et al., 2013).

It is also important to note that the DA system has received so much attention for the last decades due to its contribution to the development of drug addiction. Different drugs of abuse (alcohol, psychostimulants, opioids, nicotine etc.) are able to dramatically disrupt normal functioning of brain’s reward system (George and Koob 2010, Volkow et al., 2011; Luscher and Malenka, 2011). Notably, if acute administration of drugs of abuse leads to augmentation of DA transmission (Di Chiara and Imperato 1988), the chronic drug exposure leads to its reduction in the targeted regions (Nestler 2005, Volkow et al., 2011). Moreover, such reduction of DA transmission may contribute to the negative emotional symptoms observed between drug exposures or upon drug withdrawal (Koob and Le Moal, 2001; Nestler 2005). Thus, the mesocorticolimbic DA system may represent an important system in the initiation and maintenance of drug addiction.

2.2.1 Neurophysiology of reward

VTA DA neurons transmit DA in two modes, “tonic” and “phasic” by firing action potentials in different patterns (Grace, 1991; Grace et al., 2007). In their tonic firing mode (2–10 Hz), VTA DA neurons maintain a baseline level of extracellular DA (5–20 nM) that is vital for the normal functioning of neural circuits (Parsons and Justice, 1992; Schultz, 2007). In their phasic firing mode (up to 15–30 Hz), DA neurons can abruptly change alter their firing rates for hundreds milliseconds, leading to major changes in DA concentrations (up to 1 μ M) in downstream structures (Garris et al., 1997; Schultz et al., 1997; Schultz, 2007).

In 1997 Wolfram Schultz proposed the DA reward prediction error hypothesis. According to this hypothesis, the phasic DA responses are induced by many types of rewards and cues that predict reward, when the reward value is higher than expected, but they are inhibited when the value is lower (Schultz et al., 1997). In fact, this hypothesis has been shown to be generally applicable to many species such as rodents, primates, and humans (Cohen et al., 2012; D'Ardenne et al., 2008). Further studies on primates revealed that only some DA neurons comply with Schultz's hypothesis. It seems unlikely that all DA neurons follow this one rule independently of their diverse DA projections, and their functions. Instead, a greater number of DA neurons respond to both rewarding and aversive stimuli, in conflict with the hypothesis (Matsumoto and Hikosaka, 2009). Many recent elegant electrophysiological studies have found that VTA DA neurons exhibit very extensive heterogeneous responses to aversive stimuli (Brischoux et al., 2009; Ungless et al., 2010; Lammel et al., 2011; Wang and Tsien, 2011; Budygin et al., 2012). It is still unclear which DA neurons are able to mediate aversion. Schultz has proposed that it might be mediated by a small specific DA subpopulation (Schultz, 2013), whereas a recent study claimed that almost near equal numbers of DA neurons can be activated or inhibited in response to aversive stimulus such as tail pinch (Zweifel et al., 2011). One of the possible explanations for these controversial findings might be traced to the imprecise identification of DA neurons (discussed below). Thus, some DA neurons could be overlooked (e.g. minor DA nuclei) or misinterpreted as being non-DA neurons (Lammel et al., 2013).

2.2.2 Dopamine reward circuits

DA reward system originates from the ventral tegmental area (VTA), one of the major DA nuclei, which sends its main projections to the NAcc (~85% of projections), to the amygdala (~50%) and prefrontal cortex (mPFC, ~30%) (Swanson, 1982; Lammel et al., 2013).

Through its projections, the VTA integrates input from many brain regions including autonomic, motor, and somatosensory areas (*Figure 3*) (Watabe-Uchida et al., 2012). This thesis will mainly focus on activity of these VTA DA neurons, and its main projections. However in addition to the VTA, several minor DA nuclei in the ventrolateral periaqueductal grey (vPAG) regions also seem to be involved in the reward (Li et al., 2013). This minor DA nucleus, projecting mainly to the BNST, were found to be involved in adaptation to social isolation, anxiety, and in adaptations to acute cocaine and alcohol exposures (Meloni et al., 2006).

2.2.3 Afferent control of VTA neurons

The selective stimulation of different afferent projections to VTA, which became possible with the introduction of novel tracing and optogenetic techniques, which made it possible to demonstrate that the different excitatory and inhibitory afferent inputs to the VTA alter behavior in profoundly different ways by targeting distinct DA subpopulations (Lammel et al., 2012; Lammel et al., 2013). In particular, activation of glutamatergic projections from the laterodorsal tegmentum (LDT) to VTA DA neurons induces burst firing of VTA DA neurons and DA release in NAcc lateral shell (Lodge and Grace, 2006; Lammel et al., 2012). This selective stimulation of LDT projections elicited rewarding behavior (Lammel et al., 2012). On the other hand, stimulation of glutamatergic projections from the lateral habenula to VTA DA neurons projecting to the mPFC as well as on VTA GABA neurons in the rostromedial tegmental nucleus (also called “tail of VTA”) elicited avoidance behavior (Jhou et al., 2009; Stamatakis and Stuber, 2012; Lammel et al., 2012). A different approach was taken to examine glutamatergic projections from the ventral hippocampus to VTA DA. It has been shown that several different aversive stimuli induce robust activation of these glutamatergic projections, which resulted in activation of VTA DA neurons (Valenti et al., 2011). Other dense glutamatergic and

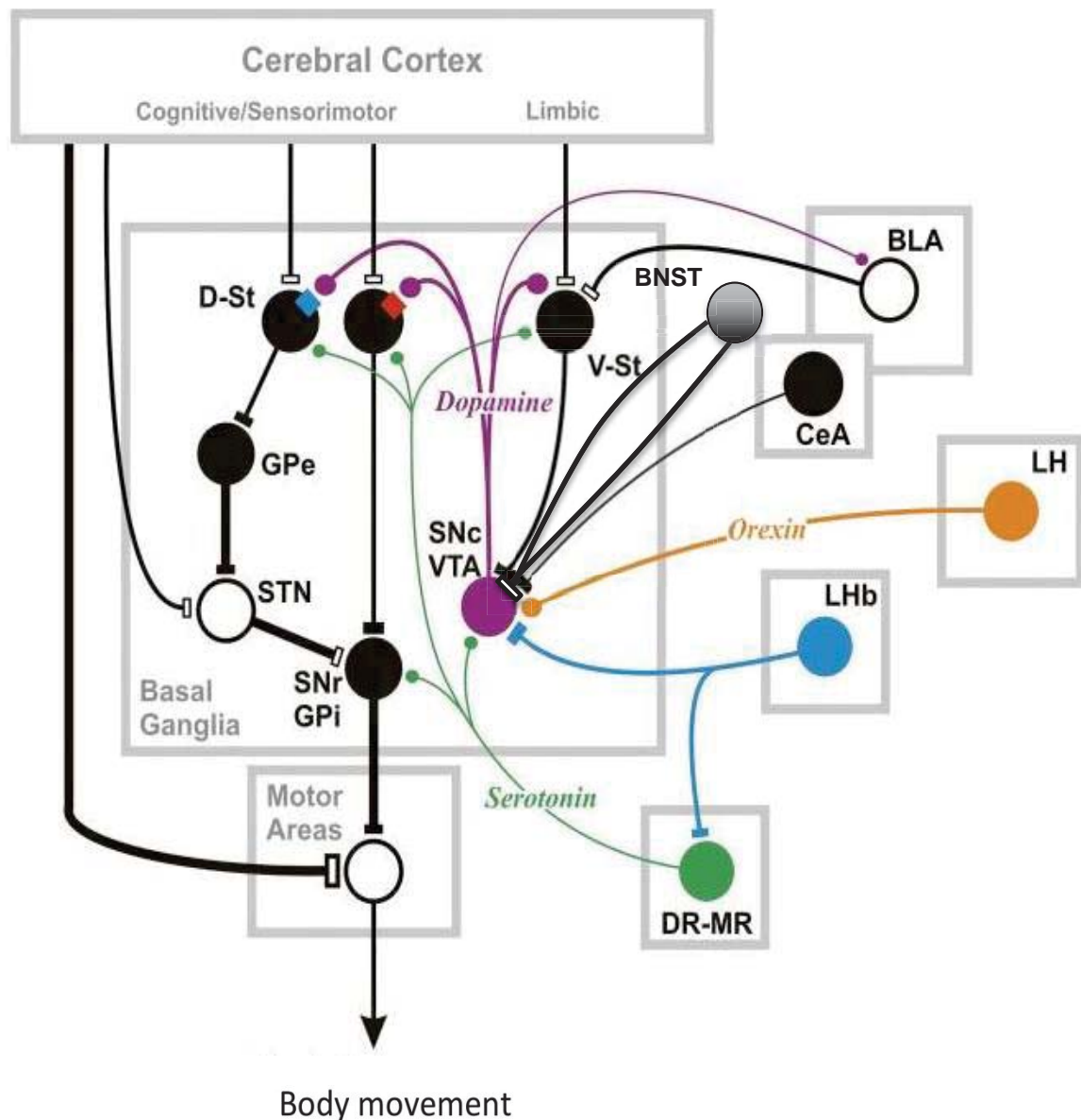

Figure 3 Main afferents and efferents of VTA involved in reward circuits. Modified from Hikosaka et al., 2008.

The activity of VTA is regulated through several systems including dopamine, GABA, glutamate, acetylcholine, serotonin, endocannabinoids and orexin. For clarity, many pathways and neuron types have been omitted. In dorsal striatum medium spiny neurons expressing dopamine D1 receptors marked with red square; expressing D2 receptors with blue square. BLA: basolateral amygdala, BNST: bed nucleus of stria terminalis, CeA: central amygdala, DR: dorsal raphe, D-St: dorsal striatum, GPe: external segment of globus pallidus, GPi: internal segment of globus pallidus, LH: lateral hypothalamus, LHb: lateral habenula, MR: medial raphe, SNc: substantia nigra pars reticulata, SNr: substantia nigra pars reticulata, STN: subthalamic nucleus, V-St: ventral striatum, VTA: ventral tegmental area. Filled circles indicate inhibitory neurons; open circles indicate excitatory neurons.

peptidergic projections come from the lateral hypothalamus (Rosin et al., 2003). Their selective stimulation promotes reward by enhancing glutamate transmission in the VTA (Kempadoo et al., 2013).

The bed nucleus stria terminalis (BNST), which integrates stress information in the reward system, sends both glutamatergic and GABAergic projections to VTA non-DA neurons (Georges and Aston-Jones, 2002; Jalabert et al., 2009; Jennings et al., 2013; Kim et al., 2013). Selective optostimulation of glutamatergic BNST projections promotes aversive and anxiety-like behavior, whereas stimulation of GABAergic BNST projections produce a more complex effect displaying rewarding and anxiolytic phenotypes in mice (Jennings et al., 2013). VTA receives other gabaergic projection from the ventral pallidum. Recently, this projection to both VTA DA and non-DA neurons was found to mediate the effects of opiates (Hjelmstad et al., 2013).

In addition, the activity of VTA is regulated by serotonergic neurons projecting from the dorsal raphe (Ferre et al., 1994), by cholinergic neurons from the pedunculopontine tegmental nucleus, and laterodorsal tegmental area (Omelchenko and Sesack, 2006), as well as endogenous opioids (Kalivas et al., 1993; Hjelmstad et al., 2013), noradrenaline (Sara, 2009), orexins (Nakamura et al., 2000), and corticotropin-releasing factor (Wanat et al., 2013).

2.2.4 Diversity of VTA neurons

Since VTA neurons (*Figure 4*) obtain such extensive afferent and efferent projections, it is not surprising that these neurons are not uniform in nature. In fact, VTA DA neurons exhibit distinct electrophysiological, molecular and anatomical properties (Margolis et al., 2006; Margolis et al., 2008; Lammel et al., 2013). They also exhibit differences in their cellular morphology (Sarti et al., 2007), and in their co-transmitters such as glutamate and GABA (Chuhma et al., 2004; El Mestikawy et al., 2011; Tritsch et al., 2012).

The recent classification of VTA DA neurons was based on the DA projection targets, since the majority of these neurons show no overlap in their projections, in other words, they follow the rule “one neuron – one target” (Fallon, 1981; Albanese and Minciacchi, 1983; Lammel et al., 2013). The combination of retrograde tracing and electrophysiology has made it possible to dissect several VTA DA subgroups

(Table 3). In particular, VTA DA neurons projecting to the medial shell of NAcc selectively respond to the rewarding stimulus. DA neurons projecting to mPFC respond only to the aversive (pain) stimulus. In contrast, DA neurons projecting to NAcc lateral shell respond to both rewarding and aversive stimuli, evidence that this mesocorticolimbic subgroup forms a distinct circuitry, which “may encode the occurrence of a salient stimulus independent of its valence” (Lammel et al., 2011).

Table 3. Summary of the basal characteristics of the midbrain DA neuron subgroups and response of their glutamatergic synapses to rewarding and aversive stimuli. Modified from Lammel et al., 2011.

DA subgroups	AMPA/NMDA ratio			
	Ih-current	basal	reward	aversion
nigrostriatal	present	low	-	-
mesolimbic lateral shell	present	low	↑	↑
mesolimbic medial shell	absent	high	↑↑	-
mesocortical	absent	high	-	↑↑

Similar to VTA DA neurons, local GABA interneurons (*Figure 4*) also can be subdivided based on their varying input and output projections (Thierry et al., 1979; Kalivas et al., 1993; Omelchenko and Sesack, 2006; Fields et al., 2007; Xia et al., 2011). In fact, VTA GABA neurons form local contacts into VTA (Omelchenko and Sesack, 2006), and also project to the pedunculopontine tegmental nucleus, NAcc and PFC (Van Bockstaele and Pickel, 1995; Carr and Sesack, 2000). Furthermore, a difference was found in their morphology, physiology and pharmacological properties such as the soma’s shape, the presence of Ih-current, durations of action potentials, sensitivity to μ -opioid receptor agonists (Chieng et al., 2011; Margolis et al., 2012).

VTA glutamatergic neurons (*Figure 4*) were recently discovered in the VTA and can be mainly found in the medial VTA (Nair-Roberts et al., 2008; Hnasko et al., 2012). These neurons appear to send a local excitatory input to both DA and GABA neurons (Dobi et al., 2010). VTA glutamate neurons, such as the VTA DA and GABA neurons, project to several different brain areas including medial PFC, NAcc, lateral habenula, ventral pallidum and amygdala (Hnasko et al., 2012; Yamaguchi et al., 2011).

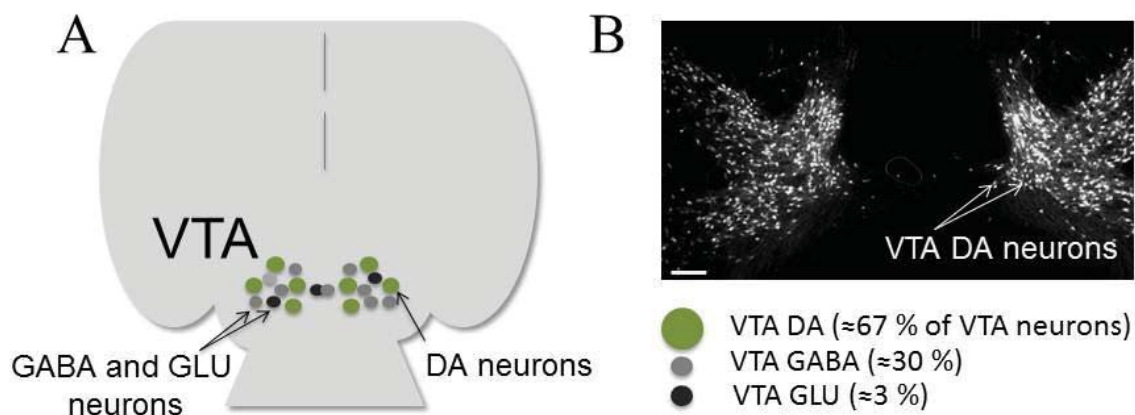

Figure 4. Schematic drawing illustrates cell types in the VTA and their distribution.

A. VTA is composed of dopaminergic (DA), GABAergic (GABA) and glutamatergic (GLU) neurons. **B.** Distribution of EGFP-labeled DA neurons in adult transgenic Th-EGFP mice. Horizontal section of the midbrain. Scale bar, 200 μm .

2.2.5 Synaptic plasticity in VTA DA neurons

Long-term potentiation (LTP) and depression (LTD) of synaptic strength are believed to be the mechanisms that underlie the ability of neural circuits to form memories (Malenka and Bear, 2004). Glutamatergic synapses on VTA DA neurons also exhibit LTP, and its induction requires NMDA receptor activation and an increase in the Ca^{2+} ion concentration within the postsynaptic dendrite (Chen et al., 2010; Luscher and Malenka, 2011). Importantly, alterations in the glutamatergic input onto VTA DA neurons have been reported to significantly alter DA release in the terminal brain regions that in turn might lead to changes in animal behaviour (Mathon et al., 2003).

Long-term depression (LTD) also can be triggered in VTA DA neurons. Depending on the induction protocol, LTD can occur through several underlying mechanisms (Kauer and Malenka, 2007). In particular, LTD can be generated by activation of voltage-dependent calcium channels and does not require NMDA receptor activation (Jones et al., 2000; Thomas et al., 2000). LTD can also be generated by activation of metabotropic glutamate receptors (Bellone and Luscher, 2006).

The increase or decrease in synaptic strengths observed in LTP and LTD, respectively, apparently involve regulation of AMPA receptor function and trafficking (Kauer and Malenka, 2007). During LTP, additional GluA2-lacking AMPA receptors are transported to the cell surface. Importantly, these new receptors exhibit some unique properties; first, greater single-channel conductance and, second, permeability to Ca^{2+} ions, which may serve to facilitate Ca^{2+} -dependent signaling events (Chen et al., 2010). Conversely, LTD is associated with AMPA receptor withdrawal from the cell surface (Hayashi et al., 2000; Bellone and Luscher, 2006; Gutlerner et al., 2002). Experimentally, the presence or absence of GluA2-lacking AMPA receptors can be determined either electrophysiologically by assessing their inward rectification, or pharmacologically by utilizing AMPA subunit-selective antagonists (Chen et al., 2010).

2.2.6 Drug-induced synaptic plasticity in VTA DA neurons

Drugs of abuse significantly activate DA signaling and increase DA release in the NAcc (Luscher and Malenka, 2011). This increase in the extracellular DA concentrations is believed to be involved in facilitating learning and memory in brain regions innervated by DA (Jay, 2003; Luscher and Malenka, 2011).

Drugs of abuse short circuit of the brain reward systems so that they “relearn” for prioritizing the value of a drug and other vital activities become secondary (Luscher and Malenka, 2011). In fact, a single injection of various drugs of abuse is already sufficient to induce LTP in glutamatergic synapses on VTA DA neurons, which drive spike generation in VTA DA neurons (Saal et al., 2003; Ungless et al., 2010). Importantly, these drug-induced adaptations appear to be stronger and more persistent than those associated with natural rewards (Volkow et al., 1999; Chen et al., 2008). Many drugs of abuse such as psychostimulants, opioids, alcohol, benzodiazepines, and nicotine exhibit different pharmacological effects, but they all induce the potentiation of AMPA receptor-mediated synaptic transmission in VTA DA neurons (*Figure 5*) (Liu et al., 2000; Ungless et al., 2001; Saal et al., 2003; Borgland et al., 2004; Dong et al., 2004; Chen et al., 2008; Engblom et al., 2008; Stuber et al., 2008; Heikkinen et al., 2009). Further studies revealed that cocaine was able to disturb both AMPA and NMDA receptor transmission (Mameli et al., 2009). LTP observed after a single cocaine injection was transient, but it lasted

approximately for 3-5 days (Saal et al., 2003). Notably, chronic treatment with cocaine (once/day for 7 days) did not further increase the duration of LTP in VTA DA neurons. VTA DA neurons were potentiated for only 5 days (Borgland et al., 2004). Thus, regardless of the number of drug injections, LTP at VTA DA neurons persisted for days, but still was transient. In addition to the potentiation of glutamatergic transmission, these drugs have been found to impair GABAergic transmission in the VTA DA neurons, by preventing LTP_{GABA}. In fact, LTP has been reported at fast inhibitory GABA_A receptor synapses in several brain regions such as the hippocampus and visual cortex. This form of LTP of GABAergic synapses (LTP_{GABA}) is triggered by NMDA receptor activation at glutamate synapses and requires nitric oxide-cGMP signaling (Nugent et al., 2007). Blockade of this LTP_{GABA} could exert an additional impact for increased release of DA by silencing local GABA neurons (Liu et al., 2000; Melis et al., 2002; Nugent and Kauer, 2008; Niehaus et al., 2010).

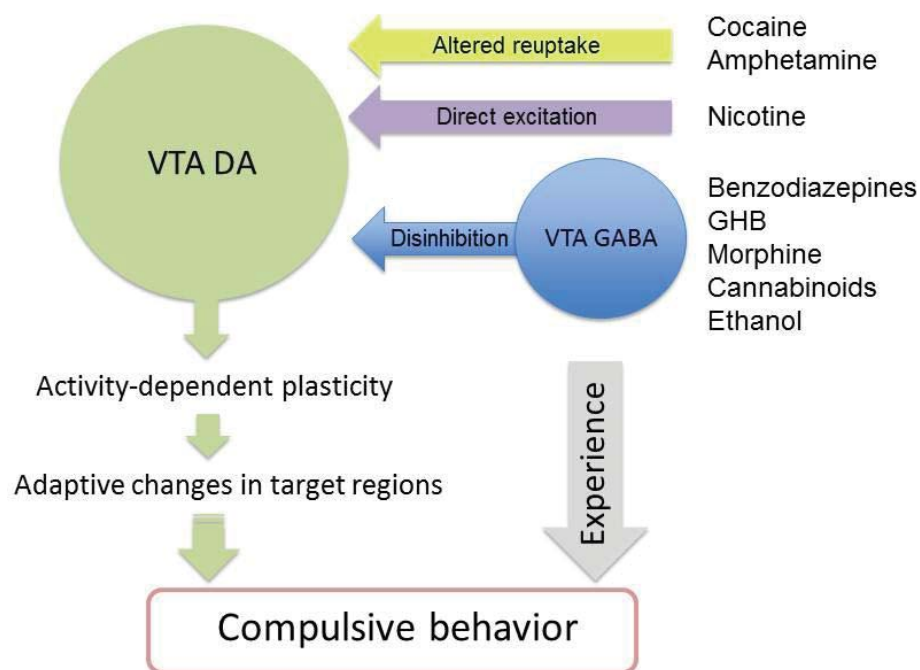

Figure. 5. Schematic of the induction of drug-induced synaptic plasticity in VTA DA neurons. Modified from Luscher 2013.

Drugs of abuse employ distinct cellular mechanisms to cause a redistribution of AMPA- and NMDA-receptors in VTA DA neurons. As a consequence, the rules for activity-dependent plasticity are altered, and these through yet to be identified signaling pathways evoke adaptive changes in target regions of the VTA. Once such adaptive changes have become consolidated, then compulsive behavior becomes apparent.

2.2.7 Modulation of dopamine system via GABAergic agents

Since the 1970s, benzodiazepines have been the most commonly used anxiolytic and sedative drugs in clinical use (Lalivé et al., 2011). They act as positive allosteric modulators of γ 2-containing GABA_A receptors (Hattori et al., 1986; Sigel and Luscher, 2011). Targeting of the benzodiazepine binding site on the GABA_A receptor results in changing the receptor's conformation that, in turn, enhances the effect of GABA. Due to the broad distribution of synaptic γ 2-containing GABA_A receptors, benzodiazepines have a very robust action resulting in several effects that possess therapeutic benefits: treatment of insomnia, anxiolysis, treatment of epileptic seizures, myorelaxation and anterograde amnesia (Sigel and Luscher, 2011).

However the situation is not only positive, in long-term use benzodiazepines cause tolerance and dependence in many patients. Their addictive properties are still poorly understood, but most likely they are at least partly mediated via DA system (Heikkinen et al., 2009). Benzodiazepine ligands potentiate glutamatergic transmission of VTA DA neurons by silencing local VTA GABA neurons (so called disinhibition). In particular, diazepam targets α 1-containing GABA_A receptors located in VTA GABA neurons, and α 3-containing GABA_A receptors in VTA DA neurons. Since GABA neurons appear to be more extensively inhibited, the net effect of benzodiazepines will be increased firing of VTA DA neurons (Heikkinen et al., 2009; Tan et al., 2010). But it is not known which subtypes of VTA DA and GABA neurons mediate this effect.

Since the α 1 subunit has been found to mediate sleep and addiction properties of benzodiazepines and also have broad expression over the brain, it has proved challenging to develop new sedative benzodiazepines without addictive properties (Rudolph and Mohler, 2004; Tan et al., 2010; Lalivé et al., 2011). Despite intense research over the years, subtype-selective and partial agonists of benzodiazepine-sensitive GABA_A receptors have failed so far (Atack, 2011; Skolnick, 2013). One possible solution to this impasse might be seek new drugs targeting the benzodiazepine-insensitive extrasynaptic GABA_A receptors. These receptors mediate tonic inhibition, display selective brain distribution and their activation appears to have a milder net effect in comparison to benzodiazepines. The effects of modulators of extrasynaptic GABA_A receptors on DA reward system should be still clarified.

An early *in vivo* study of agonists of extrasynaptic GABA_A receptors revealed that muscimol and THIP could dose-dependently increase the firing rates of DA neurons (Waszczak et al., 1980). Furthermore, the δ subunit has been found to be expressed in VTA and its main targets such as NAcc, mPFC and hippocampus (Pirker et al., 2000; Okada et al., 2004; Xiao et al., 2007). New drugs targeting these δ -containing GABA_A receptors are considered to be potential therapeutic benefits for several CNS disorders, and several drugs are already under clinical trials. Thus, it is clearly important to characterize the effects of these drugs on the DA system.

3 AIMS OF THE STUDY

GABA_A receptor-mediated tonic inhibition is considered to be an important inhibitory mechanism in the brain. However, the physiological implications of the tonic inhibition of the DA reward circuitry are poorly understood. In order to elucidate its action on DA neurons, the effects of extrasynaptic GABA_A receptor modulators were characterized at the cellular and behavioral levels. The aims of this study were as follows:

1. To study whether enhanced GABA_A receptor-mediated tonic inhibition by selective modulators with distinct modes of action could induce neuroplasticity in VTA DA neurons, and if so, to clarify underlying cellular mechanisms (I, II).
2. To investigate the behavioral significance of the induced synaptic plasticity by characterizing reward-related behaviors across the species (I, II).
3. To clarify activation of which brain areas could be involved in THIP-induced aversive behavioral effects and/or neuroplasticity on VTA DA neurons (III).

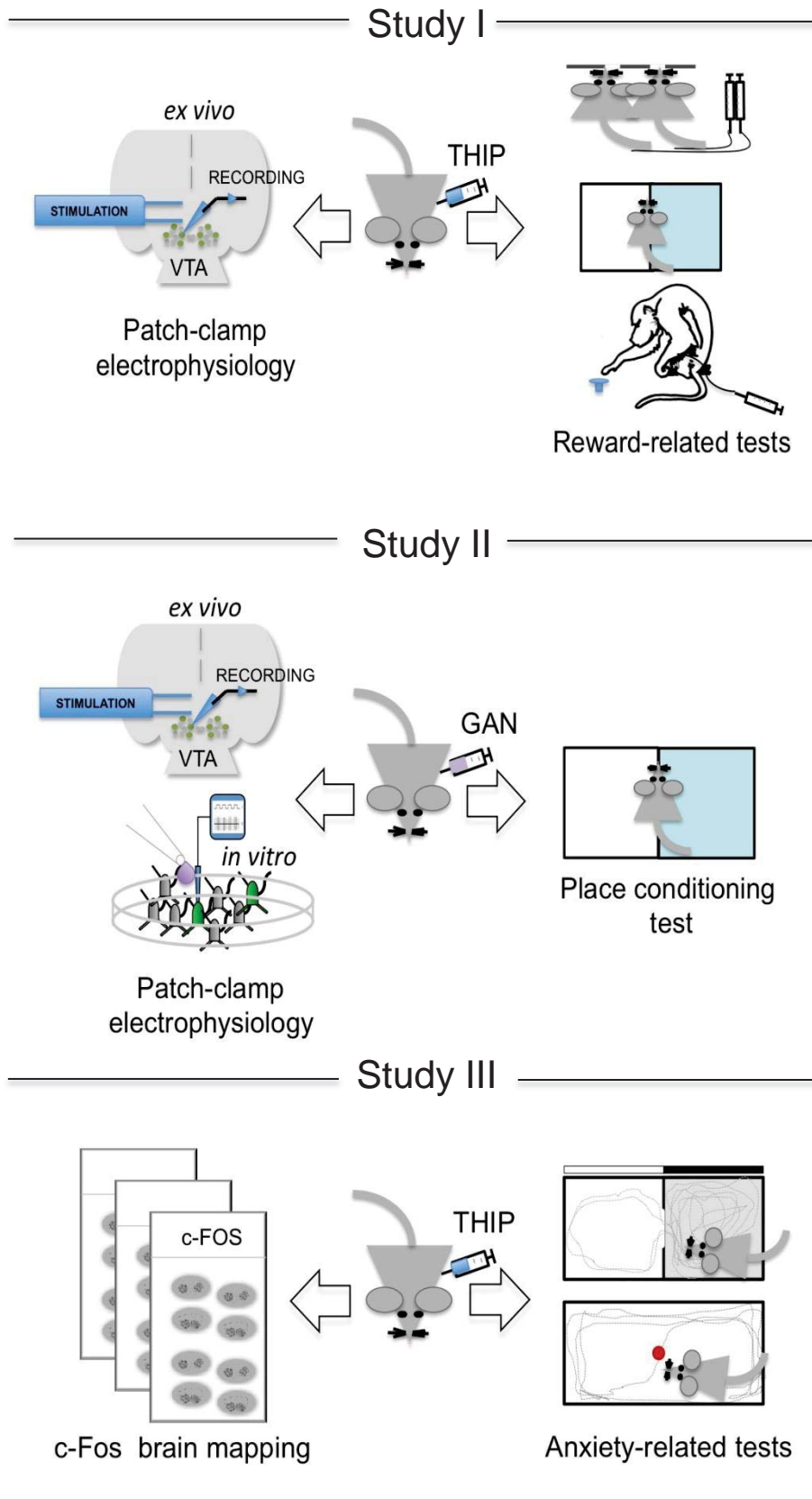

Figure 6. A summary of the main steps involved in studying VTA synaptic plasticity and reward-related behaviors after the treatment with gabaxodol (THIP) and ganaxolone (GAN), modulators of extrasynaptic GABA_A receptors, in studies I-III.

4 MATERIALS AND METHODS

The materials and methods are described in greater detail in the “Materials and Methods” sections of the original articles I-III. All experimental procedures were approved by the Southern Finland Provincial Government. Only those procedures are listed in this chapter where the author was personally involved. All suppliers of drugs and equipment are indicated in the original publications and not mentioned here.

4.1 EXPERIMENTAL ANIMALS

C57BL/6J mice (Charles River Laboratories), transgenic Th-EGFP (Gong et al., 2003), GAD67-GFP knockin mice (Tamamaki et al., 2003) and GABA_A receptor δ subunit-knockout (δ -KO) mice and their wild type littermates (δ -WT) (Mihalek et al., 1999) were maintained at our facility. Only males were used in the experiments at the age of 21-28 days (young mice) or 10-13 weeks (adult mice) unless otherwise indicated. The mice were group-housed under a 12-h light/dark cycle with food and water available *ad libitum*.

4.2 ELECTROPHYSIOLOGICAL STUDIES

Synaptic responses were measured using a whole-cell patch-clamp technique (Sakmann and Neher, 1984). AMPA/NMDA ratio, rectification index and miniature AMPA excitatory postsynaptic current (mEPSCs) were applied to elicit long-term changes in the efficacy of glutamatergic synaptic transmission (Heikkinen et al., 2009; Tan et al., 2010). Possible changes in presynaptic function were checked by assessing the paired-pulse facilitation ratio (Dobrunz and Stevens, 1997). In the study

of the basic properties of GABA_A receptor-mediated transmission, GABAergic currents were pharmacologically isolated and spontaneous inhibitory postsynaptic currents (sIPSC) were recorded (Semyanov et al., 2003).

4.2.1 Acute midbrain VTA-slice preparation

Horizontal midbrain slices (225 μ m) were obtained from young mice using a vibrating blade microtome (Vibratome 1000 plus). After cutting, the slices were allowed to recover for 1 h at 37 °C before the recordings were started.

4.2.2 Identification of the targeted neurons

In Th-EGFP and GAD67-GFP mice, both VTA DA and GABA neurons were visualized using a fluorescence microscope (Olympus BX51WI). In δ -KO and δ -WT mice, the DA neurons were identified if a clear *I_h*-current was observed after voltage clamping cells from -70 to -120 mV in 10 mV steps (Heikkinen et al., 2009).

4.2.3 Electrophysiological recordings and data analysis

The currents were amplified (Multiclamp 700A), low-pass filtered at 1.6 kHz, and digitized at 20 kHz (Molecular Devices). According to protocols, neurons were voltage-clamped at a holding potential of -70 mV or +40 mV. The access and membrane resistances were monitored throughout the experiment. Recordings were discarded if the access resistance changed >20% during the experiment. Recorded events were analyzed offline by using ClampFit (pClamp 10) or Mini Analysis software (Synaptosoft).

4.3 BEHAVIORAL STUDIES

Sedative effect of drugs in the animals was determined by their locomotor activity in the open field test. The rewarding profile of the drugs was determined by intravenous drug self-administration and place conditioning (conditioned place preference) paradigms. The anxiety-related profile of drugs was studied in light-dark exploration and open field with new object exploration tests. Acute stress was elicited with a modified forced swim task.

4.3.1 Locomotor activity of mice

Mice were placed in the polycarbonate box and allowed to freely explore the activity chamber (Heikkinen et al., 2009). Traveled distance was measured automatically by Ethovision Color-Pro 3.1 software (Noldus Information Technology).

4.3.2 Light-dark choice test

Mice were placed into the lit compartment of the light-dark box apparatus (Med Associates). The duration and distance of the movement, number of transitions between compartments, the first latency to enter the lit compartment were automatically measured by Med Associates software (Crawley and Goodwin, 1980; van Rijn et al., 2010).

4.3.2 Individual exploratory behavior

The test was subdivided into two parts. Initially, a mouse was placed in the center of the open field arena for 3 min and then a yellow plastic ball (new object) was quickly installed for another 3 min (Vekovischeva et al., 2013). The duration and distance of the movement, the first latency to enter center and contact the new object were analyzed subsequently using Ethovision and Ethograph 2.06 software (RITEC).

4.3.3 Place-conditioning for preference/aversion

Conditioning took place in two different contexts based on an unbiased paradigm (Cunningham et al., 2006). The drug conditioning context was Plexiglas chamber with metal grids on the floor whereas the control context was a Plexiglas chamber with plastic floor. After 4 conditioning sessions, mice were allowed to choose between the above contexts in the test session. Their activity was constantly monitored by Ethovision Color-Pro 3.1 software.

4.3.4 Intravenous drug self-administration in mice

Mice were tested in pairs, one active and one yoked control, in the individual chambers (RITEC). Each chamber had a nose-poking hole equipped with infrared sensor. During the “pre-test” session, mice were subsequently paired according to their basal nose-poke activity. During the 20-min test, each nose poke of the active

mouse resulted in a simultaneous infusion of the same drug through tail vein to both active and yoked mice. The reinforcing properties of drugs were then assessed by the calculation of the reinforcement factor (Kuzmin et al., 1994).

4.4 IMMUNOHISTOCHEMICAL STUDIES

Expression of the immediate early gene c-Fos was chosen as an efficient technique for screening of neuronal activation of widespread regions of the brain (Hughes and Dragunow, 1995).

4.4.1 c-Fos immunohistochemistry

After drug treatment, brains were dissected, frozen on dry ice and stored at -80°C . Immunostaining was performed as described by Procaccini et al. (2011). Fourteen- μm -thick coronal sections were stained for goat anti- c-Fos antibody (1:800) using horse anti-goat secondary antibody (1:200). The c-Fos-immunopositive cells were visualised using the avidin–biotin peroxidase complex and diaminobenzidine with nickel sulphate intensification.

Under light microscopy, immunopositive cells were identified by dense black nuclear staining in 25 brain areas confirmed by reference to a mouse brain atlas (Franklin 2008) with automatic detection of immunopositive cells, constant thresholds of light intensity and object size being maintained across all animals within a region of interest with Image J software (National Institutes of Health). Four sections per mouse for each brain region were counted (observer blinded to the treatment) and averaged.

4.5 STATISTICAL TESTS

All data were analyzed using GraphPad Prism 5 (GraphPad Software) and PASW Statistics 18 (SPSS Inc.). The statistical significance of the differences between groups with equal variances was assessed with t-test or analysis of variance (ANOVA), followed by post-hoc Bonferroni's or Dunnett's tests. Statistical significance of the differences between groups with unequal variances was assessed with nonparametric Mann-Whitney or Kruskal-Wallis test followed by Dunn's test.

Table 3. Summary of the methods, results and conclusions of studies I-III

Methods	Results	Conclusions
AMPA/NMDA ratio	THIP (1-3 mg/kg) no effect, THIP (6 mg/kg) ↑, in δ-KO mice THIP (6 mg/kg) no effect in VTA DA cells	THIP induced persistent neuroadaptations in VTA DA similar to the drugs of abuse. In contrast to their reinforcing profiles, THIP produced persistent aversive place conditioning and did not maintain self-administration in either mice or baboons. We propose that this represents a new way of modulation of the reward system via activation extrasynaptic GABA _A receptors
Rectification index	THIP (6 mg/kg) ↑ in VTA DA cells	
Paired-pulse ratio	THIP (6 mg/kg) no effect in VTA DA cells	
mEPCs	↑ frequency after THIP (6 mg/kg) in VTA DA cells	
sIPCSs	↓ frequency after acute THIP (1 μM) in VTA DA cells	
Place conditioning in mice	THIP (3 mg/kg) no effect, THIP (6 mg/kg)	
IV self-administration in mice and baboons	THIP no effect	
AMPA/NMDA ratio	GAN (10 mg/kg) no effect, GAN (30 mg/kg) ↑, in δ-KO mice GAN (30 mg/kg) no effect in VTA DA cells	These findings further support the idea of distinct modulation of the reward system via extrasynaptic receptors. Here, a neurosteroid agonist activates extrasynaptic GABA _A receptors via distinct binding site(s) from THIP. The neurosteroid induced persistent plasticity in the excitatory synapses on DA neurons via increased tonic inhibition of VTA GABA neurons. In the behavioral tests GAN produced conditioned place aversion, but this did not occur in GABA _A receptor δ-KO mice.
Rectification index	GAN (10 mg/kg) no effect, GAN (30 mg/kg) ↑ in VTA DA cells	
Tonic current	GAN (500 nM) ↑ in VTA GABA cells	
sIPSC	GAN (500 nM) no effect in VTA DA and GABA cells	
Place conditioning in mice	GAN (30 mg/kg) conditioned place aversion, in δ KO mice GAN (30 mg/kg) no effect	

c-Fos mapping	Areas activated by THIP (6 mg/kg) in young mice: CeM, CeL, PVA; in adult mice: BNST	These findings might help to dissect specific DA projections that are essential for reinforcing and aversive behavior. THIP elevated the number of c-Fos+ cells in the BNST and induced anxiety-like behavior in the adult mice, evidence that the BNST might be involved in mediating the aversive effects of THIP
Light-dark choice box	Latency to enter the lit compartment after THIP (6 mg/kg) ↑	
Open field with new object	Latency to enter the center of arena and to contact of new object after THIP (6 mg/kg) ↑	

5 RESULTS AND DISCUSSION

5.1 THIP AND GANAXOLONE INDUCED PERSISTENT LTP OF GLUTAMATERGIC SYNAPSES ON VTA DA NEURONS (STUDY I, II)

Previous studies had shown that several addictive drugs including benzodiazepines selectively evoke a potentiation of glutamatergic currents in VTA DA neurons (Ungless et al., 2001; Saal et al., 2003; Heikkinen et al., 2009). This study was conducted in order to compare the effects of extrasynaptic GABA_A receptor modulators with those induced by the synaptic GABA_A receptor modulators benzodiazepines. Thus, it was decided to use relatively similar doses of THIP and ganaxolone based on their sedative effects (Heikkinen et al., 2009). Both modulators after a single administration promoted persistent changes of glutamatergic transmission which lasted for several days (*Table 3*).

5.1.1 THIP and GAN increased AMPA/NMDA receptor-mediated current ratio in Th-EGFP mice (I, II)

The direct GABA_A receptor agonist THIP (1-6 mg/kg, i.p.) dose-dependently increased the AMPA/NMDA ratio in VTA DA neurons measured 24 h after the *in vivo* injection (*Study I, Figure 2*). The observed effect was similar to that found in earlier studies after *in vivo* administration of ethanol, which was used as a positive control (Saal et al., 2003).

THIP acts at the same binding site as GABA in the interphase of α and β

subunits of the GABA_A receptors. In contrast, neurosteroids are able to modulate GABA_A receptors via distinct sites (Hosie et al., 2006), but still retaining a preference for the δ subunit-containing receptors. The administration of the synthetic neurosteroid ganaxolone (GAN, 10-30 mg/kg, i.p.) resulted in a similar dose-dependent increase of AMPA/NMDA ratio (*Study II, Figure 1*). Importantly, both THIP and GAN induced plasticity for at least 6 days, while benzodiazepines cause this effect for only 3 days (Heikkinen et al, 2009).

It is noteworthy mentioning that this study used a different approach for identification of VTA DA neurons than previously used in the benzodiazepine study (Heikkinen et al, 2009). The use of the bacterial artificial chromosome (BAC) Th-EGFP mouse line made it possible to avoid the complications of DA neuron identification via their physiological properties such as the presence of *I_h*-current (Gong et al., 2003; Lammel et al., 2011; Margolis et al., 2008). However, other BAC mouse lines that were produced to investigate D1 and D2 DA-receptor expressing neurons have recently been reported to display aberrant behavioral responses to cocaine (Kramer et al., 2011) and alterations in NAcc synaptic plasticity (Bageetta et al., 2012). Thus, concentrations of DA and its metabolites in several brain regions were determined in order to ascertain that the present mouse model would not react differently to the effects of studied drugs. There were no significant differences in the levels of DA or its metabolites in the caudate-putamen/NAcc region and prefrontal cortex between the Th-EGFP mice and their littermates without the transgene (*Study II*). Furthermore, additional post hoc analysis of responses of VTA DA neurons between several mouse strains (Th-EGFP vs δ -KO) also did not reveal any significant differences (*Study II*).

In these studies, it was not possible to discern any specific subpopulation (or subpopulations) of VTA DA neurons that was (were) activated by these modulators. Both THIP and GAN seem to affect several DA populations, which is supported by the following two observations. First, mapping of the recorded VTA DA cells revealed a homogeneous pattern of activation (*Study I, Figure 3*). Second, *I_h*-positive and -negative VTA DA neurons, which have been suggested to belong to distinct DA subclasses (Lammel et al., 2011), responded to both THIP and GAN in the same manner (*Study I, II*). Further experiments will be needed to establish whether there are

specific VTA DA neuron subpopulations (and their afferent inputs) that are affected selectively by certain drugs of abuse (Lammel et al., 2011; Fiorillo et al., 2013).

5.1.2 THIP and GAN were unable to induce glutamate neuroplasticity in δ -KO mice

Earlier studies had demonstrated that the δ subunit is required for both THIP and GAN effects, but in relation to tonic inhibition, the present results do not completely rule out the contribution of other GABA_A receptor subtypes, particularly $\alpha 3$ and $\alpha 5$ subtypes (Mihalek et al., 1999; Uusi-Oukari and Korpi, 2010; Walker and Kullmann, 2012). These receptors can also sense a low concentration of GABA and can be tonically active (Caraiscos et al, 2004; Marowsky et al, 2012). In order to confirm the selective action of the drugs on extrasynaptic δ -containing GABA_A receptors, the experiments were repeated in δ -KO mice, which lack these receptors and the high-affinity agonist sites (Mihalek et al., 1999; Chandra et al., 2006). Indeed, both THIP (*Study I, Figure 7*) and GAN (*Study II, Figure 3*) failed to increase the AMPA/NMDA ratio in VTA DA neurons 24 h after drug treatment in δ -KO mice. In contrast, the δ -WT littermates exhibited a similar glutamate plasticity as observed in Th-EGFP mice.

Although knockout mouse models can be considered as a great tool for evaluation of drug selectivity, the gene deletion often leads to compensatory mechanisms. In particular, changes in GABA_A receptors of δ -KO mice are not limited to the loss of the δ subunit in the forebrain. These δ -KO mice have a strong upregulation of $\gamma 2$ and a downregulation of $\alpha 4$, which may complicate the attribution of results to the δ -containing GABA_A receptors (Korpi et al., 2002; Peng et al., 2002). In the present study, one cannot exclude the possibility that the above compensatory mechanisms would also take place in the VTA and NAcc. However, the data indicate that the δ -KO mice do not show glutamate neuroplasticity after an injection of THIP or GAN. These results can be most easily explained by the lack of tonic inhibition rather than by a possible compensation via increased synaptic inhibition (which actually was not affected in VTA DA or GABA neurons of Th-EGFP by GAN *in vitro* (*Study II, Table 1*)).

5.1.3 Mechanism of THIP-induced glutamate neuroplasticity. Electrophysiological study

To clarify the mechanism underlying the THIP-induced glutamate plasticity, it was decided to perform a battery of electrophysiological tests. First, spontaneous miniature AMPA receptor-mediated EPSCs (mEPSCs) were recorded in the VTA DA neurons at 24 h after the drug treatment to study changes of excitatory transmission of VTA DA neurons. THIP (6 mg/kg) increased both amplitudes and frequency of events (*Study I, Figure 4*). This increase of AMPA receptor-mediated transmission could reflect either presynaptic or postsynaptic changes such as an increase in the number of AMPA receptors or even in the number of synapses.

In an attempt to distinguish between these scenarios, the paired-pulse ratio in the VTA DA neurons was examined to assess the possible presynaptic mechanism of long-term plasticity (Mallart and Martin, 1968; Maren and Fanselow, 1995). Since the ratio did not differ from control, it was confirmed that no change had occurred in the probability of neurotransmitter release was confirmed (*Study I, Figure 4*).

Therefore, the increase in the amplitude and frequency of AMPA mEPSCs was due to some postsynaptic changes. The inward rectification in the *I-V* relation of AMPA receptor EPSCs (so called rectification index test) was then assessed to ascertain subunit composition of AMPA receptors. Perturbations in the receptor subunit composition can have a direct effect on synaptic transmission (see chapter 2.2.5). If the AMPA receptor lacks GluA2 subunit(s), then it can be blocked by intracellular polyamines at positive potentials. Hence, when the neuron is depolarized, GluA2-lacking AMPA receptors exhibit their inwardly rectifying property, which means that they pass less outward current than inward current (Dingledine et al., 1999). It was found that THIP treatment induced potentiation in the VTA DA neurons through insertion of new GluA2-lacking receptors (*Study I, Figure 5*), since THIP treatment increased the rectification.

Earlier extensive studies have been carried out to characterize VTA neuroplasticity and the mechanisms underlying its induction induced by drugs of abuse, particularly by cocaine (Ungless et al., 2001; Borgland et al., 2004; Bellone and Luscher, 2006; Mameli et al., 2007; Argilli et al., 2008). Intriguingly, the fact that

the drugs have different molecular targets, and thus distinctive drug-induced behavior, similar changes were observed in glutamatergic transmission after a single exposure to the drugs.

Whereas immunocytochemical and in situ hybridization studies demonstrated a modest expression of the extrasynaptic GABA_A receptors in the VTA (Korpi et al., 2002; Hortnagl et al., 2013), the heterogeneity of this area complicates the pinpointing of possible cellular targets for THIP. Therefore, the acute effect of THIP on the inhibitory transmission of VTA DA neurons was evaluated by monitoring their sIPSC (*Study I, Figure 5*). Direct application of THIP led to a net decrease of the total inhibitory current in VTA DA neurons. The conclusion from this in vitro experiment was that THIP most likely acts on extrasynaptic GABA_A receptors present on the local GABA neurons, and their resulting silencing seems to be sufficient to cause potentiation of DA neurons. These results are consistent with recent findings which have demonstrated the presence of functional extrasynaptic GABA_A receptors on presynaptic GABAergic terminals targeting VTA DA neurons (Xiao et al., 2007).

In summary, THIP induced persistent changes in glutamatergic transmission of VTA DA neurons at least in part through the insertion of new GluA2-lacking AMPA receptors. Furthermore, this synaptic plasticity depended on extrasynaptic δ -containing GABA_A receptors within the VTA.

5.1.4 Tonic inhibition in VTA

Whereas tonic inhibitory currents were presented in both VTA DA and GABA neurons (*Study II, Figure 2*), these tonic currents most likely have a more profound inhibitory effect on VTA GABA than DA neurons. Since GABA neurons have a higher input resistance, this property allows the same charge transfer to more effectively change the membrane potential of GABA neurons than that of DA neurons (Margolis et al, 2006; Margolis et al, 2012).

Both VTA DA and GABA neurons exhibit extensive diversities in the magnitude of tonic inhibitory current amplitudes (10-30 pA). Some recorded neurons expressed no tonic current. Several explanations of such variation may be outlined: first, VTA neurons are heterogeneous with respect to their physiological and

pharmacological properties; second, VTA neurons exhibit temporal differences in inhibitory transmission. It has been postulated that ambient GABA concentration is one of the factors that determine the magnitude of tonic inhibitory currents. The concentrations of ambient GABA can vary drastically (from nM to μ M range) in response to different physiological and experimental conditions (Tossman et al., 1986; Kennedy et al., 2002).

All in all, it can be stated that the VTA is a novel brain region which together with the hippocampus, cerebellum, cortex, amygdala and thalamic nuclei, whose activity can be tuned through additional control of tonic inhibition (Semyanov et al., 2003; Mody and Pearce, 2004; Marowsky et al., 2012). It is noteworthy that not all brain regions that have been inspected exhibit tonic currents under normal conditions. For instance, tonic inhibition is normally not observed in hippocampal pyramidal neurons in adult rodents (Semyanov et al., 2003; Caraiscos et al., 2004).

5.1.5 Mechanism of GAN-induced glutamate neuroplasticity. Electrophysiological studies

The general pattern of results obtained in experiments with GAN is consistent with the findings on the modulation of VTA DA neurons by THIP (*Study I*). The AMPA/NMDA ratio and rectification index tests revealed that GAN induced persistent changes of glutamatergic transmission, at least in part via insertion of new GluA2-lacking AMPA receptors (*Study II, Figure 1*).

Direct application of GAN (500 nM) onto the VTA resulted in a fast and selective increase of tonic inhibition in VTA GABA cells (*Study II, Figure 2*). The range of effective neurosteroid concentrations with respect to the prolongation of the IPSC event depends on several aspects including local and developmental differences (Lambert et al, 2003). For instance, nanomolar concentrations of neurosteroids are effective in the cerebellar granule and Purkinje cells, whereas high micromolar concentrations of neurosteroids are needed to exert effects in the hypothalamic nuclei (Lambert et al, 2003). Even within the same brain region there may be neuronal populations with different neurosteroid sensitivities: hippocampal CA1 neurons are 30-fold more sensitive to neurosteroids than the dentate granule neurons. Furthermore, the sensitivity to neurosteroids appears to depend on developmental

changes of GABA_A receptor subunit composition: younger animals are more sensitive to neurosteroids than their adult counterparts (Lambert et al, 2003).

Next, it was demonstrated that local application of GAN onto VTA was sufficient to induce synaptic plasticity in VTA DA neurons. In particular, GAN (500 nM) caused significantly increased AMPA/NMDA ratios in VTA DA neurons within 4-6 h, which is consistent with the time frame of the cocaine-induced increase in the AMPA/NMDA ratio (Argilli et al., 2008). Thus, this experiment supports local mechanisms, but does not exclude the possibility that *in vivo* drug effects from other brain regions could be important for neuroplasticity or behavioral conditioning.

Taken together with the results in δ -KO mice described above, it is concluded that GAN *ex vivo* induced glutamate receptor neuroplasticity in VTA DA neurons via increased tonic inhibition of VTA GABA neurons. These results are in agreement with earlier studies demonstrating that allopregnanolone could induce an increase in the extracellular DA levels in the NAcc, in a similar manner as muscimol and THIP (Kalivas et al., 1990; Rouge-Pont et al., 2002).

5.2 BEHAVIORAL SIGNIFICANCE OF THE SYNAPTIC PLASTICITY INDUCED IN THE VTA

The behavioral consequences of THIP- and GAN- induced synaptic plasticity in the VTA (or in the brain) were probably one of the most intriguing questions to be clarified. Since numerous studies revealed an impact of DA system in encoding drug reward, attribution of incentive salience and motivation, it was decided to study several reward-related behavioral paradigms, which covered both primary unconditioned incentive (reinforcing) and secondary conditioned incentive (rewarding) properties of drugs by drug self-administration and conditioned place preference (CPP), respectively.

5.2.1 THIP exerted no reinforcement, but instead induced conditioned aversion in wild-type mice and baboons

Primary rewarding properties of THIP were studied in mice by the intravenous self-administration protocol based on the yoked-control paradigm (Criswell and Ridings, 1983). In this test, which is able to evoke a significant self-administration of several drugs of abuse (Kuzmin and Zvartau, 1991; Martellotta et al., 1995; Kuzmin and Johansson, 2000), no significant differences in rates of self-administration were observed in C57BL/6J mice between vehicle and different doses of THIP (0.1-3.0 mg/ml). Hence, no rewarding properties of THIP were established, in contrast to D-amphetamine (0.5 mg/ml), which was used as a positive control (*Study I, Figure 8A,B*).

In collaboration with Bjarke Ebert and Nancy Ator, it was possible to demonstrate that baboons in a different self-administration paradigm did not administer THIP at any studied doses (0.1-1 mg/kg/injection), in contrast they did inject the benzodiazepine agonist triazolam (0.01 mg/kg/injection) and cocaine (0.32 mg/kg/injection) (*Study I, Figure 8C*). This result offered further evidence that THIP does not induce any reinforcement in different species.

The secondary rewarding properties of THIP was studied by the unbiased conditioned place preference (CPP) test. In this test, C57BL/6J mice unexpectedly avoided the environment associated earlier with a THIP dose of 6 mg/kg (*Study I, Figure 9*). Moreover, these behavioral results demonstrated correlation with the electrophysiological data, since low THIP doses failed to induce glutamate receptor plasticity *ex vivo* and behavioral aversion compared with saline.

The interpretation of this data requires a degree of caution due the fact that the electrophysiological studies (see chapter 5.1) employed young mice, whereas the behavioral studies were conducted in adults. This has been done due to several methodological reasons. In particular, patch-clamping becomes more challenging in adult mice because the neuronal membranes become stiffer, and it is more difficult to maintain the long-term stability of the recordings. On the other hand, young mice showing higher levels of neuroplasticity can be more sensitive to acute drug effects (e.g. Panhelainen et al., 2011), and perhaps react to conditioning differently than

adults. CPP in young animals has not been detected in several studies with alcohol, amphetamine (Adriani and Laviola, 2003; Song et al., 2007).

One of the possible explanations for observed conditioned aversion could be the fact that THIP treatment could induce absence seizures (also called petit mal seizures) (Fariello and Golden, 1987). Typical absence seizures are characterized by a brief altered state of consciousness (no longer than 30 s), and they can be detected as bilaterally synchronous spike-and-wave discharges in electroencephalography (Crunelli and Leresche, 2002). In fact, enhancement of tonic inhibition in thalamocortical neurons is known to result in neuronal hyperpolarization, and so a change of thalamocortical neuron firing from a regular to a burst pattern, would promote the above spike-wave generation. On the other hand, γ -hydroxybutyric acid (GHB) has also been found to induce absence seizures, at least in part via δ -containing GABA_A receptors. In contrast to THIP, GHB induces CPP in both mice and rats. Future studies using anticonvulsants like ethosuximide to prevent the possible induction of these types of seizures during THIP conditioning may be informative in this regard.

It was interesting to evaluate the primary and secondary rewarding properties of THIP and to compare them to other reinforcing drugs. Whereas THIP induced persistent synaptic plasticity in VTA DA neurons in a same way as benzodiazepines, the behavioral consequences of THIP-induced synaptic plasticity were different and could be seen as CPA, in contrast to diazepam-induced CPP (Imazumi et al., 2000). The distinct VTA intra-circuits seem to express different receptors and thus may differently modulate animal behavior.

5.2.2 GAN induced conditioned aversion in wild-type mice, but not in δ -KO mice

The CPP results for GAN were consistent with the findings on THIP (*Study I*). Once again, GAN dose-dependently induce conditioned place aversion (CPA) in C57BL/6J mice. In order to examine underlying mechanism of observed GAN-induced CPA, it was decided to use the same protocol in δ -KO mice. The lack of δ -containing GABA_A receptors prevented the induction of conditioned aversion.

In the next experiment, the hypothermic effects of GAN and THIP were examined to determine whether they might influence performance in the drug-induced CPP test. Despite inducing similar CPA, GAN and THIP produced different effects on body temperature; THIP had hardly any effects on the core temperature of the mice (*Study II, Figure 4*). Thus, it is reasonable to conclude that hypothermia was not responsible for the aversive behavior.

Interestingly, δ -KO mice responded similarly as their WT littermates, suggesting that this hypothermic response was mediated by targets other than δ -containing GABA_A receptors. This conclusion is consistent with a previous study that reported no change in ethanol-induced hypothermia in δ -KO mice (Mihalek et al., 2001). Apparently, the GAN-induced aversion but not its hypothermic effect is dependent on δ -subunit-containing GABA_A receptors. Hypothermia does not appear to be the reason for the aversive conditioning evoked by GAN.

The interpretation of data obtained from δ -KO mice may have been complicated by compensatory adaptations, which could occur in neuronal circuitry during development (see 5.1.2). In addition the complete deletion of δ -containing GABA_A receptors is not able to answer the question of whether δ -containing GABA_A receptors located within the VTA are responsible for the observed drug-induced synaptic plasticity and/or behavior. Therefore, the specific deletion of the δ -containing GABA_A receptors within VTA for instance by viral-mediated RNAi in adult mice would be a potential genetic solution to this problem (Nie et al., 2011). It would also be important to perform additional experiments with microinjections of THIP and GAN into the VTA or its main targets mPFC/NAcc to clarify the role of the δ -containing GABA_A receptor in GAN-mediated aversion.

5.3 MECHANISM OF THIP-INDUCED GLUTAMATE PLASTICITY. THE c-FOS STUDY

To understand which inputs participate in the THIP-induced VTA neuroplasticity and following conditioned aversive behavior, it was decided to study activation of immediate early gene c-Fos in several brain areas after acute THIP administration.

The expression of c-Fos is a nonspecific marker of neuronal activity as c-Fos is often expressed in neurons that are firing (Hughes and Dragunow, 1995; Svarnik et al., 2005). The c-Fos was studied in both young and adult mice in order to clarify earlier electrophysiological data obtained in young mice (*Study I, II*), and behavioral data in adult mice (*Study I, II*). It was found that there was a stronger pattern of c-Fos activation in young mice. Particularly, in young mice THIP induced c-Fos activation in the central nuclei of amygdala and paraventricular nucleus of thalamus (*Study III, Figure 1, Table 1*), whereas in adult mice THIP induced selective activation of the BNST neurons (*Study III, Figure 2, Table 1*).

Interestingly, THIP induced a different c-Fos pattern from the modulators of synaptic GABA_A receptors, benzodiazepines. In particular, sedative doses of diazepam are known to induce a distinct activation pattern (Panhelainen and Korpi, 2012), which can be explained by the more extensive distribution of synaptic GABA_A receptors (Pirker et al., 2000). However, it is still possible that THIP may activate neurons without turning on c-Fos (Kovacs, 1998). Thus in the future it would be important to use additional markers of neuronal activity such as Arc (Link et al., 1995), and also examine a more detailed time course.

The BNST, which was selectively activated by THIP, is an important connective center between brain stress and reward centers. This region has been implicated in the collecting and processing of stress axis information and integrating this into the reward/motivation circuitry (Georges and Aston-Jones, 2001; Georges and Aston-Jones, 2002; Jennings et al., 2013). The BNST is composed of primarily GABAergic neurons (Cullinan et al., 1993), with smaller a contribution of glutamatergic neurons (Jalabert et al., 2009). Additionally, neuropeptides such as CRF, enkephalin, neuropeptide Y, dynorphin, and substance P are present in some BNST neurons (Sparta et al., 2013). Thus, in the future, it would be important to perform colocalization studies to reveal subtype, receptor, and intracellular signaling protein expression of the neurons being activated by THIP treatment. Further by taking advantage of novel transgenic c-fos-mRFP1 or Fos/EGFP animal models (Fujihara et al., 2009), these THIP-activated neurons could be studied in vitro, for instance by patch-clamp and live imaging to characterize signaling pathways, electrophysiological properties and drug-induced adaptations within the neurons. In

addition, the application of neurotoxins that might selectively “turn off” THIP-activated cells may be able to clarify the functional importance of THIP-activated pathway.

Probably, the most interesting finding from this study was the behavioral validity of THIP-induced BNST activation. It was found that treatment with THIP provoked anxiety-like behavior in mice seen in both light-dark choice and open field tests (*Study III, Figure 3, Table 2*), a result consistent with a recent optogenetic study demonstrating that BNST-VTA (glutamatergic) projections exhibited a net enhancement of firing during an aversive event (Jennings et al., 2013; Kim et al., 2013). Thus, there is anatomical and behavioral evidence propose a role of BNST in the aversive effects of THIP and/or VTA neuroplasticity.

5.4 AVERSIVE THIP EFFECTS IN ABUSERS. ITS LIMITATIONS TO TREAT PRIMARY INSOMNIA

Could the present results demonstrating anxiety-like after effects and aversive conditioning in THIP-treated mice (*Study I,III*) be related to aversive THIP effects in humans? If this were to be the case, the current battery of behavioural approaches (including CPP, anxiety-related tests) might be used in diagnostics to evaluate the potential aversive drug properties. In fact, THIP has been noted to provoke undesirable feeling of unreality and poor concentration in anxious patients (Hoehn-Saric et al., 1983). Moreover, THIP at supra-therapeutic doses exhibited certain psychiatric side effects in an abuse liability study involving drug abusers. Some of these patients experienced feelings such as “euphoria, feeling abnormal, dizziness, paresthesia, dissociation, restlessness, and thinking abnormal”, as well as “aversive effects like anxiety, fear, headache, nausea, vomiting, and muscle twitching” (Schoedel et al., 2009). The mechanisms underlying these aversive THIP effects have not yet been identified.

Regardless of the earlier studies success (Faulhaber et al., 1997; Mathias et al., 2005; Walsh et al., 2007; Lankford et al., 2008), recent three-month study revealed only limited or variable efficacy of THIP [38% of patients on THIP (15 mg) vs 15%

of placebo patients] (Roth et al., 2010). Thus, the risk-to-benefit ratio for THIP has been too unfavorable to meet the Food and Drug Administration's (FDA) requirements for marketing approval (drugs.com downloaded in November 2013). It is still unclear why the drug was ineffective in the above studies. One potential explanation may be related to results from a series of in vitro and in vivo studies on proton-coupled amino acid transporter (PAT1, Slc36a1). The PAT1 is thought to be a transporter that increases the intestinal absorption of THIP (Larsen et al., 2009; Larsen et al., 2010). In particular, in view of the control of THIP absorption, is the fact that serotonin, tryptamine, 5-hydroxy-L-tryptophan, and sertraline (selective serotonin reuptake inhibitor, SSRI, compound used in the clinic to treat depression) can drastically diminish absorption of the drug via some unknown indirect mechanism (Frolund et al., 2011; Nielsen et al., 2013). Given that compulsive use of the drugs of abuse disturb the normal functioning of the serotonergic system, THIP could have had an abnormal effect in drug abusers (Kirby et al., 2011).

A second possibility could arise from transporters through which THIP penetrates the BBB. Although there is no available literature on THIP- transporters, one of the possible candidates could be the large neutral amino acid transporter type 1 (LAT1), an important drug transporter (Huwlyer and Pardridge, 1998). The human LAT1 gene has several single-nucleotide polymorphisms (SNP's) in the open reading frame (e.g. NM_003486). Hypothetically this polymorphism could be envisaged to modify the penetration of THIP (i.e. either reducing or increasing BBB penetration) leading to variable brain concentrations and different effects between individuals.

Another possible explanation for the aversive and ineffective THIP treatment could arise from differences in food consumption. According to the Food and Agriculture Organization of the United Nations, meat consumption (source of amino acids) differs between the U.S. and European populations (in 2009: 120 vs 80 kg/capita/year, <http://faostat.fao.org>). Intriguingly, nutritionally-relevant mixtures of amino acids promote activation of orexin/hypocretine neurons via inhibition of KATP channels and activation of system-A amino acid transporters (Venner et al., 2011). Since these orexin/hypocretine neurons regulate the sleep-wake cycle, their activation might lead to further inhibition of ventrolateral preoptic nucleus (VLPO), the main target for THIP in promoting sleep (Lu and Greco, 2006). Thus, this orexin-induced

VLPO inhibition might make THIP ineffective in a population consuming a high-protein diet. Furthermore, orexin neurons directly modulate the mesocorticolimbic DA circuit expressing OX1- and OX2- receptors in VTA DA, as well as NAcc and mPFC (Borgland and Labouebe, 2010; Yan et al., 2012). There is growing evidence indicating that orexin neurons have also been implicated in the pathology of psychiatric disorders, including schizophrenia, depression, and addiction. This raises the interesting possibility that orexin receptor agonists, which are currently in development for the treatment of narcolepsy, may also have some antidepressant-like activity (Borgland and Labouebe, 2010). In summary, discovering new molecular targets for sedative drugs lacking side effects has proven difficult and it might be unrealistic to think that it will be possible to develop preparations suitable for everybody. Instead, further development of pharmacogenetics and personalized medicine could be one other promising strategy to open up entirely new clinical opportunities.

In conclusion, the experiments presented here have clearly demonstrated the obligatory role of extrasynaptic GABA_A receptors in the modulation of the mesolimbic DA system. By manipulating synaptic activity in the DA system (and/or in other neurotransmitter systems) via extrasynaptic stimulation, it may be possible to reverse the rewarding effects of addictive drugs. In fact, alcohol intake in rodents has been shown to be reduced after treatment with THIP and GAN (Ramaker et al., 2011; Ramaker et al., 2012). As well GAN is currently tested as a smoking cessation candidate in Phase II (clinicaltrials.gov, NCT01857531). On the other hand, chronic treatment with neurosteroids might accelerate development of Alzheimer's disease in several mouse models (Bengtsson et al., 2012; Bengtsson et al., 2013). Moreover, reduction of tonic inhibition has been shown to promote functional recovery after stroke (Clarkson et al., 2010; Santhakumar et al., 2010). However, studies far beyond the scope of this dissertation will be required to understand the true contribution of extrasynaptic GABA_A receptors and their modulators in the normal and pathological function of the brain. Development of new drugs, which can selectively activate/inhibit extrasynaptic GABA_A receptors, may contribute to the elimination of imbalance in tonic GABAergic signaling associated with several pathological conditions.

6 CONCLUSIONS

The results of this study provide some of the first evidence that tonic inhibition plays an important role in the modulation of reward dopamine system, and that its pharmacological induction leads to persistent neuroadaptations of excitatory transmission of VTA DA neurons and conditioned aversive behavior:

1. Enhanced tonic inhibition by THIP and GAN induces synaptic plasticity of glutamate synapses on VTA DA neurons. Despite having distinct modes of action, both drugs selectively target δ -containing GABA_A receptors located on VTA GABA neurons. The tonic inhibition induced in these neurons appears to be sufficient to disinhibit DA neurons. The subsequent synaptic plasticity in VTA DA neurons, results from insertion of new GluA2-lacking AMPA receptors.
2. Behaviorally, THIP produced conditioned place aversion in mice, which was still evident one month after the last conditioning. Furthermore, THIP failed to induce any reinforcement during self-administration in either mice or baboons. GAN, like THIP, was able to evoke conditioned place aversion, and this effect was absent in δ -KO mice. These findings led to the hypothesis that δ -containing GABA_A receptors mediate aversively conditioned behavior.
3. The activity of BNST neurons was increased acutely by THIP administration. Behaviorally, this could be seen as anxiety-like behavior in adult mice. These findings point to a selective set of subcortical nuclei which could take part in THIP-induced aversive behavioral effects and/or neuroplasticity on VTA DA neurons.

7 ACKNOWLEDGEMENTS

This work was carried out in the Institute of Biomedicine of the University of Helsinki, during the years 2008-2013. It was supported by the funds of the Center for International Mobility (CIMO), the Finnish Foundation for Alcohol Studies, Academy of Finland, Sigrid Juselius Foundation and the Finnish Graduate School of Neuroscience and Brain & Mind.

First and foremost I would like to thank my supervisor Esa Korpi for his continual support and advice throughout my studies. Esa's broad experience, wisdom, kindness and Finnish "sisu" (strength of will) never ceased to impress and educate me. Despite his never-ending hectic schedule, his door was always open to me. I could not have asked for a better mentor.

I would like to express my sincere thanks to Kimmo Jensen for agreeing to act as my opponent at the public defense of this dissertation.

I am grateful to Tarja Stenberg and Mikko Airavaara for their expert criticism and their help in improving this manuscript. I thank Ewen MacDonald for reviewing the language of my thesis.

I am grateful to Olga Vekovischeva. Our many conversations regarding science or personal matters will always be memorable. Olga truly was the ideal colleague and I could only wish that I will work with other people like her in the future. I wish to thank Anni-Maja Linden and Petri Hyytiä. I learned a great deal from them and benefited tremendously from their scientific advice.

I would like to thank Ilya Kirilkin, Svetlana Molchanova, and Holger Rabe who have patiently shared their knowledge and skills with me on intricacy of electrophysiology. I also thank our electrophysiology-team, Tommi Möykkynen,

Nobuyoshi Tajima, and Anne Panhelainen, who were always there to help me through any problems I encountered.

I wish to thank heartily all past and present personnel at Pharmacology for creating inspiring day-to-day scientific and joyful atmosphere. My special thanks are to Heidi Pehkonen for technical support. I could always count on her help and high professionalism in the lab.

I wish to thank Veera Alanen and Julia Johansson, who completed undergraduate projects within the scope of my studies. I hope my guidance was of value for your future careers.

I would like to thank all my friends in Saint Petersburg and Helsinki, who have supported and encouraged me through all these years and who filled my life with unforgettable moments. Thanks also to the high-speed train Allegro, which made it possible.

Finally, I must acknowledge the support of my family for putting up with the fact that I live hundreds kilometers away. Especially, I thank my parents who have put so much effort into ensuring that I received a good education during difficult times in modern Russia.

8 REFERENCES

- Adriani W, Laviola G (2003) Elevated levels of impulsivity and reduced place conditioning with d-amphetamine: two behavioral features of adolescence in mice. *Behav Neurosci* 117:695-703.
- Albanese A, Minciacchi D (1983) Organization of the ascending projections from the ventral tegmental area: a multiple fluorescent retrograde tracer study in the rat. *J Comp Neurol* 216:406-420.
- Argilli E, Sibley DR, Malenka RC, England PM, Bonci A (2008) Mechanism and time course of cocaine-induced long-term potentiation in the ventral tegmental area. *J Neurosci* 28:9092-9100.
- Atack JR (2011) GABA_A receptor subtype-selective modulators. II. $\alpha 5$ -selective inverse agonists for cognition enhancement. *Curr Top Med Chem* 11:1203-1214.
- Bagetta V, Sgobio C, Pendolino V, Del Papa G, Tozzi A, Ghiglieri V, Giampa C, Zianni E, Gardoni F, Calabresi P, Picconi B (2012) Rebalance of striatal NMDA/AMPA receptor ratio underlies the reduced emergence of dyskinesia during D2-like dopamine agonist treatment in experimental Parkinson's disease. *J Neurosci* 32:17921-17931.
- Bai D, Zhu G, Pennefather P, Jackson MF, MacDonald JF, Orser BA (2001) Distinct functional and pharmacological properties of tonic and quantal inhibitory postsynaptic currents mediated by γ -aminobutyric acid(A) receptors in hippocampal neurons. *Mol Pharmacol* 59:814-824.
- Barnard EA, Skolnick P, Olsen RW, Mohler H, Sieghart W, Biggio G, Braestrup C, Bateson AN, Langer SZ (1998) International Union of Pharmacology. XV. Subtypes of γ -aminobutyric acidA receptors: classification on the basis of subunit structure and receptor function. *Pharmacol Rev* 50:291-313.
- Belelli D, Callachan H, Hill-Venning C, Peters JA, Lambert JJ (1996) Interaction of positive allosteric modulators with human and Drosophila recombinant GABA receptors expressed in *Xenopus laevis* oocytes. *Br J Pharmacol* 118:563-576.
- Belelli D, Herd MB (2003) The contraceptive agent Provera enhances GABA_A receptor-mediated inhibitory neurotransmission in the rat hippocampus: evidence for endogenous neurosteroids? *J Neurosci* 23:10013-10020.
- Belelli D, Peden DR, Rosahl TW, Wafford KA, Lambert JJ (2005) Extrasynaptic GABA_A receptors of thalamocortical neurons: a molecular target for hypnotics. *J Neurosci* 25:11513-11520.
- Bellone C, Luscher C (2006) Cocaine triggered AMPA receptor redistribution is reversed in vivo by mGluR-dependent long-term depression. *Nat Neurosci* 9:636-641.
- Bengtsson SK, Johansson M, Backstrom T, Nitsch RM, Wang M (2013) Brief but chronic increase in allopregnanolone cause accelerated AD pathology differently in two mouse models. *Curr Alzheimer Res.* 2013 Jan;10(1):38-47.
- Bengtsson SK, Johansson M, Bäckström T, Wang M (2012) Chronic allopregnanolone treatment accelerates Alzheimer's disease development in A β PP(Swe)PSEN1(Δ E9) mice. *J Alzheimers Dis.* 2012;31(1):71-84.
- Biagini G, Panuccio G, Avoli M (2010) Neurosteroids and epilepsy. *Curr Opin Neurol* 23:170-176.
- Birnir B, Eghbali M, Everitt AB, Gage PW (2000) Bicuculline, pentobarbital and diazepam modulate spontaneous GABA_A channels in rat hippocampal neurons. *Br J Pharmacol* 131:695-704.
- Birnir B, Everitt AB, Lim MS, Gage PW (2000) Spontaneously opening GABA_A channels in CA1 pyramidal neurones of rat hippocampus. *J Membr Biol* 174:21-29.

- Boehm SL, 2nd, Homanics GE, Blednov YA, Harris RA (2006) δ -Subunit containing GABA_A receptor knockout mice are less sensitive to the actions of 4,5,6,7-tetrahydroisoxazolo-[5,4-c]pyridin-3-ol. *Eur J Pharmacol* 541:158-162.
- Bonin RP, Labrakakis C, Eng DG, Whissell PD, De Koninck Y, Orser BA (2011) Pharmacological enhancement of δ -subunit-containing GABA_A receptors that generate a tonic inhibitory conductance in spinal neurons attenuates acute nociception in mice. *Pain* 152:1317-1326.
- Borghese CM, Storustovu S, Ebert B, Herd MB, Belelli D, Lambert JJ, Marshall G, Wafford KA, Harris RA (2006) The δ subunit of γ -aminobutyric acid type A receptors does not confer sensitivity to low concentrations of ethanol. *J Pharmacol Exp Ther* 316:1360-1368.
- Borgland SL, Labouebe G (2010) Orexin/hypocretin in psychiatric disorders: present state of knowledge and future potential. *Neuropsychopharmacology* 35:353-354.
- Borgland SL, Malenka RC, Bonci A (2004) Acute and chronic cocaine-induced potentiation of synaptic strength in the ventral tegmental area: electrophysiological and behavioral correlates in individual rats. *J Neurosci* 24:7482-7490.
- Brickley SG, Cull-Candy SG, Farrant M (1996) Development of a tonic form of synaptic inhibition in rat cerebellar granule cells resulting from persistent activation of GABA_A receptors. *J Physiol* 497 (Pt 3):753-759.
- Brickley SG, Mody I (2012) Extrasynaptic GABA_A receptors: their function in the CNS and implications for disease. *Neuron* 73:23-34.
- Bright DP, Renzi M, Bartram J, McGee TP, MacKenzie G, Hosie AM, Farrant M, Brickley SG (2011) Profound desensitization by ambient GABA limits activation of δ -containing GABA_A receptors during spillover. *J Neurosci* 31:753-763.
- Brischoux F, Chakraborty S, Brierley DI, Ungless MA (2009) Phasic excitation of dopamine neurons in ventral VTA by noxious stimuli. *Proc Natl Acad Sci U S A* 106:4894-4899.
- Brown N, Kerby J, Bonnert TP, Whiting PJ, Wafford KA (2002) Pharmacological characterization of a novel cell line expressing human $\alpha 4\beta 3\delta$ GABA_A receptors. *Br J Pharmacol* 136:965-974.
- Budygin EA, Park J, Bass CE, Grinevich VP, Bonin KD, Wightman RM (2012) Aversive stimulus differentially triggers subsecond dopamine release in reward regions. *Neuroscience* 201:331-337.
- Caraiscos VB, Elliott EM, You-Ten KE, Cheng VY, Belelli D, Newell JG, Jackson MF, Lambert JJ, Rosahl TW, Wafford KA, MacDonald JF, Orser BA (2004) Tonic inhibition in mouse hippocampal CA1 pyramidal neurons is mediated by $\alpha 5$ subunit-containing γ -aminobutyric acid type A receptors. *Proc Natl Acad Sci U S A* 101:3662-3667.
- Carr DB, Sesack SR (2000) Projections from the rat prefrontal cortex to the ventral tegmental area: target specificity in the synaptic associations with mesoaccumbens and mesocortical neurons. *J Neurosci* 20:3864-3873.
- Carter RB, Wood PL, Wieland S, Hawkinson JE, Belelli D, Lambert JJ, White HS, Wolf HH, Mirsadeghi S, Tahir SH, Bolger MB, Lan NC, Gee KW (1997) Characterization of the anticonvulsant properties of ganaxolone (CCD 1042; 3 α -hydroxy-3 β -methyl-5 α -pregnan-20-one), a selective, high-affinity, steroid modulator of the γ -aminobutyric acid(A) receptor. *J Pharmacol Exp Ther* 280:1284-1295.
- Chandra D, Halonen LM, Linden AM, Procaccini C, Hellsten K, Homanics GE, Korpi ER (2010) Prototypic GABA_A receptor agonist muscimol acts preferentially through forebrain high-affinity binding sites. *Neuropsychopharmacology* 35:999-1007.
- Chandra D, Jia F, Liang J, Peng Z, Suryanarayanan A, Werner DF, Spigelman I, Houser CR, Olsen RW, Harrison NL, Homanics GE (2006) GABA_A receptor $\alpha 4$ subunits mediate extrasynaptic inhibition in thalamus and dentate gyrus and the action of gaboxadol. *Proc Natl Acad Sci U S A* 103:15230-15235.
- Chandra D, Werner DF, Liang J, Suryanarayanan A, Harrison NL, Spigelman I, Olsen RW, Homanics GE (2008) Normal acute behavioral responses to moderate/high dose ethanol in GABA_A receptor $\alpha 4$ subunit knockout mice. *Alcohol Clin Exp Res* 32:10-18.

- Chen BT, Bowers MS, Martin M, Hopf FW, Guillory AM, Carelli RM, Chou JK, Bonci A (2008) Cocaine but not natural reward self-administration nor passive cocaine infusion produces persistent LTP in the VTA. *Neuron* 59:288-297.
- Chen BT, Hopf FW, Bonci A (2010) Synaptic plasticity in the mesolimbic system: therapeutic implications for substance abuse. *Ann N Y Acad Sci* 1187:129-139.
- Chieng B, Azriel Y, Mohammadi S, Christie MJ (2011) Distinct cellular properties of identified dopaminergic and GABAergic neurons in the mouse ventral tegmental area. *J Physiol* 589:3775-3787.
- Chuhma N, Zhang H, Masson J, Zhuang X, Sulzer D, Hen R, Rayport S (2004) Dopamine neurons mediate a fast excitatory signal via their glutamatergic synapses. *J Neurosci* 24:972-981.
- Clarkson AN, Huang BS, Macisaac SE, Mody I, Carmichael ST (2010) Reducing excessive GABA-mediated tonic inhibition promotes functional recovery after stroke. *Nature* 468:305-309.
- Cohen JY, Haesler S, Vong L, Lowell BB, Uchida N (2012) Neuron-type-specific signals for reward and punishment in the ventral tegmental area. *Nature* 482:85-88.
- Collinson N, Kuenzi FM, Jarolimek W, Maubach KA, Cothliff R, Sur C, Smith A, Otu FM, Howell O, Atack JR, McKernan RM, Seabrook GR, Dawson GR, Whiting PJ, Rosahl TW (2002) Enhanced learning and memory and altered GABAergic synaptic transmission in mice lacking the $\alpha 5$ subunit of the GABA_A receptor. *J Neurosci* 22:5572-5580.
- Concas A, Pierobon P, Mostallino MC, Porcu P, Marino G, Minei R, Biggio G (1998) Modulation of γ -aminobutyric acid (GABA) receptors and the feeding response by neurosteroids in *Hydra vulgaris*. *Neuroscience* 85:979-988.
- Conde V, Palomar FJ, Lama MJ, Martinez R, Carrillo F, Pintado E, Mir P (2013) Abnormal GABA-mediated and cerebellar inhibition in women with the fragile X premutation. *J Neurophysiol* 109:1315-1322.
- Crawley J, Goodwin FK (1980) Preliminary report of a simple animal behavior model for the anxiolytic effects of benzodiazepines. *Pharmacol Biochem Behav* 13:167-170.
- Criswell HE, Ridings A (1983) Intravenous self-administration of morphine by naive mice. *Pharmacol Biochem Behav* 18:467-470.
- Crunelli V, Leresche N (2002) Childhood absence epilepsy: genes, channels, neurons and networks. *Nat Rev Neurosci* 3:371-382.
- Cullinan WE, Herman JP, Watson SJ (1993) Ventral subicular interaction with the hypothalamic paraventricular nucleus: evidence for a relay in the bed nucleus of the stria terminalis. *J Comp Neurol* 332:1-20.
- Cunningham CL, Gremel CM, Groblewski PA (2006) Drug-induced conditioned place preference and aversion in mice. *Nat Protoc* 1:1662-1670.
- D'Ardenne K, McClure SM, Nystrom LE, Cohen JD (2008) BOLD responses reflecting dopaminergic signals in the human ventral tegmental area. *Science* 319:1264-1267.
- Dingledine R, Borges K, Bowie D, Traynelis SF (1999) The glutamate receptor ion channels. *Pharmacol Rev* 51:7-61.
- Dobi A, Margolis EB, Wang HL, Harvey BK, Morales M (2010) Glutamatergic and nonglutamatergic neurons of the ventral tegmental area establish local synaptic contacts with dopaminergic and nondopaminergic neurons. *J Neurosci* 30:218-229.
- Dobrunz LE, Stevens CF (1997) Heterogeneity of release probability, facilitation, and depletion at central synapses. *Neuron* 18:995-1008.
- Dong Y, Saal D, Thomas M, Faust R, Bonci A, Robinson T, Malenka RC (2004) Cocaine-induced potentiation of synaptic strength in dopamine neurons: behavioral correlates in GluRA(-/-) mice. *Proc Natl Acad Sci U S A* 101:14282-14287.
- Drasbek KR, Hoestgaard-Jensen K, Jensen K (2007) Modulation of extrasynaptic THIP conductances by GABA_A-receptor modulators in mouse neocortex. *J Neurophysiol* 97:2293-2300.

- Ebert B, Thompson SA, Saounatsou K, McKernan R, Krosggaard-Larsen P, Wafford KA (1997) Differences in agonist/antagonist binding affinity and receptor transduction using recombinant human γ -aminobutyric acid type A receptors. *Mol Pharmacol* 52:1150-1156.
- Ebert B, Wafford KA, Deacon S (2006) Treating insomnia: Current and investigational pharmacological approaches. *Pharmacol Ther* 112:612-629.
- Ebert B, Wafford KA, Whiting PJ, Krosggaard-Larsen P, Kemp JA (1994) Molecular pharmacology of γ -aminobutyric acid type A receptor agonists and partial agonists in oocytes injected with different α , β , and γ receptor subunit combinations. *Mol Pharmacol* 46:957-963.
- El Mestikawy S, Wallen-Mackenzie A, Fortin GM, Descarries L, Trudeau LE (2011) From glutamate co-release to vesicular synergy: vesicular glutamate transporters. *Nat Rev Neurosci* 12:204-216.
- Engblom D, Bilbao A, Sanchis-Segura C, Dahan L, Perreau-Lenz S, Bolland B, Parkitna JR, Lujan R, Halbout B, Mameli M, Parlato R, Sprengel R, Luscher C, Schutz G, Spanagel R (2008) Glutamate receptors on dopamine neurons control the persistence of cocaine seeking. *Neuron* 59:497-508.
- Enoch MA (2008) The role of GABA_A receptors in the development of alcoholism. *Pharmacol Biochem Behav* 90:95-104.
- Fallon JH (1981) Collateralization of monoamine neurons: mesotelencephalic dopamine projections to caudate, septum, and frontal cortex. *J Neurosci* 1:1361-1368.
- Fancsik A, Linn DM, Tasker JG (2000) Neurosteroid modulation of GABA IPSCs is phosphorylation dependent. *J Neurosci* 20:3067-3075.
- Fariello RG, Golden GT (1987) The THIP-induced model of bilateral synchronous spike and wave in rodents. *Neuropharmacology* 26:161-165.
- Farrant M, Nusser Z (2005) Variations on an inhibitory theme: phasic and tonic activation of GABA_A receptors. *Nat Rev Neurosci* 6:215-229.
- Faulhaber J, Steiger A, Lancel M. (1997) The GABA_A agonist THIP produces slow wave sleep and reduces spindling activity in NREM sleep in humans. *Psychopharmacology*:130(3):285-91.
- Feng Y, Kapornai K, Kiss E, Tamas Z, Mayer L, Baji I, Daroczi G, Benak I, Kothencne VO, Dombovari E, Kaczvinszk E, Besnyo M, Gadoros J, Szekely J, Kovacs M, Vetro A, Kennedy JL, Barr CL (2010) Association of the GABRD gene and childhood-onset mood disorders. *Genes Brain Behav* 9:668-672.
- Ferre S, Cortes R, Artigas F (1994) Dopaminergic regulation of the serotonergic raphe-striatal pathway: microdialysis studies in freely moving rats. *J Neurosci* 14:4839-4846.
- Fields HL, Hjelmstad GO, Margolis EB, Nicola SM (2007) Ventral tegmental area neurons in learned appetitive behavior and positive reinforcement. *Annu Rev Neurosci* 30:289-316.
- Fiorillo CD, Yun SR, Song MR (2013) Diversity and homogeneity in responses of midbrain dopamine neurons. *J Neurosci* 33:4693-4709.
- Fodor L, Biro T, Maksay G (2005) Nanomolar allopregnanolone potentiates rat cerebellar GABA_A receptors. *Neurosci Lett* 383:127-130.
- Franklin K., Paxinos G. (2008) *The mouse brain in stereotaxic coordinates*. Academic Press, San Diego.
- Fritschy JM, Benke D, Mertens S, Oertel WH, Bachi T, Mohler H (1992) Five subtypes of type A γ -aminobutyric acid receptors identified in neurons by double and triple immunofluorescence staining with subunit-specific antibodies. *Proc Natl Acad Sci U S A* 89:6726-6730.
- Frolund S, Rapin N, Nielsen CU (2011) Gaboxadol has affinity for the proton-coupled amino acid transporter 1, SLC36A1 (hPAT1)--A modelling approach to determine IC(50) values of the three ionic species of gaboxadol. *Eur J Pharm Sci* 42:192-198.
- Fujihara H, Ueta Y, Suzuki H, Katoh A, Ohbuchi T, Otsubo H, Dayanithi G, Murphy D (2009) Robust up-regulation of nuclear red fluorescent-tagged fos marks neuronal

- activation in green fluorescent vasopressin neurons after osmotic stimulation in a double-transgenic rat. *Endocrinology* 150:5633-5638.
- Garris PA, Christensen JR, Rebec GV, Wightman RM (1997) Real-time measurement of electrically evoked extracellular dopamine in the striatum of freely moving rats. *J Neurochem* 68:152-161.
- Gasparly HL, Wang W, Richerson GB (1998) Carrier-mediated GABA release activates GABA receptors on hippocampal neurons. *J Neurophysiol* 80:270-281.
- George O, Koob GF. (2010) Individual differences in prefrontal cortex function and the transition from drug use to drug dependence. *Neurosci Biobehav Rev.*:232-47.
- Georges F, Aston-Jones G (2002) Activation of ventral tegmental area cells by the bed nucleus of the stria terminalis: a novel excitatory amino acid input to midbrain dopamine neurons. *J Neurosci* 22:5173-5187.
- Georges F, Aston-Jones G (2001) Potent regulation of midbrain dopamine neurons by the bed nucleus of the stria terminalis. *J Neurosci* 21:RC160.
- Glykys J, Peng Z, Chandra D, Homanics GE, Houser CR, Mody I (2007) A new naturally occurring GABA_A receptor subunit partnership with high sensitivity to ethanol. *Nat Neurosci* 10:40-48.
- Gong S, Zheng C, Doughty ML, Losos K, Didkovsky N, Schambra UB, Nowak NJ, Joyner A, Leblanc G, Hatten ME, Heintz N (2003) A gene expression atlas of the central nervous system based on bacterial artificial chromosomes. *Nature* 425:917-925.
- Grace AA (1991) Regulation of spontaneous activity and oscillatory spike firing in rat midbrain dopamine neurons recorded in vitro. *Synapse* 7:221-234.
- Grace AA, Floresco SB, Goto Y, Lodge DJ (2007) Regulation of firing of dopaminergic neurons and control of goal-directed behaviors. *Trends Neurosci* 30:220-227.
- Gutlerner JL, Penick EC, Snyder EM, Kauer JA (2002) Novel protein kinase A-dependent long-term depression of excitatory synapses. *Neuron* 36:921-931.
- Hanchar HJ, Wallner M, Olsen RW (2004) Alcohol effects on γ -aminobutyric acid type A receptors: are extrasynaptic receptors the answer? *Life Sci* 76:1-8.
- Hattori K, Oomura Y, Akaike N (1986) Diazepam action on γ -aminobutyric acid-activated chloride currents in internally perfused frog sensory neurons. *Cell Mol Neurobiol* 6:307-323.
- Hayashi Y, Shi SH, Esteban JA, Piccini A, Poncer JC, Malinow R (2000) Driving AMPA receptors into synapses by LTP and CaMKII: requirement for GluR1 and PDZ domain interaction. *Science* 287:2262-2267.
- Heikkinen AE, Moykkynen TP, Korpi ER (2009) Long-lasting modulation of glutamatergic transmission in VTA dopamine neurons after a single dose of benzodiazepine agonists. *Neuropsychopharmacology* 34:290-298.
- Heulens I, D'Hulst C, Van Dam D, De Deyn PP, Kooy RF (2012) Pharmacological treatment of fragile X syndrome with GABAergic drugs in a knockout mouse model. *Behav Brain Res* 229:244-249.
- Hikosaka O, Bromberg-Martin E, Hong S, Matsumoto M (2008) New insights on the subcortical representation of reward. *Curr Opin Neurobiol* 18:203-208.
- Hjelmstad GO, Xia Y, Margolis EB, Fields HL (2013) Opioid modulation of ventral pallidal afferents to ventral tegmental area neurons. *J Neurosci* 33:6454-6459.
- Hnasko TS, Hjelmstad GO, Fields HL, Edwards RH (2012) Ventral tegmental area glutamate neurons: electrophysiological properties and projections. *J Neurosci* 32:15076-15085.
- Hoehn-Saric R. (1983) Effects of THIP on chronic anxiety. *Psychopharmacology*; 80(4):338-41.
- Hoestgaard-Jensen K, Dalby NO, Wolinsky TD, Murphey C, Jones KA, Rottlander M, Frederiksen K, Watson WP, Jensen K, Ebert B (2010) Pharmacological characterization of a novel positive modulator at $\alpha 4\beta 3\delta$ -containing extrasynaptic GABA_A receptors. *Neuropharmacology* 58:702-711.

- Hortnagl H, Tasan RO, Wieselthaler A, Kirchmair E, Sieghart W, Sperk G (2013) Patterns of mRNA and protein expression for 12 GABA_A receptor subunits in the mouse brain. *Neuroscience* 236:345-372.
- Hosie AM, Wilkins ME, da Silva HM, Smart TG (2006) Endogenous neurosteroids regulate GABA_A receptors through two discrete transmembrane sites. *Nature* 444:486-489.
- Hughes P, Dragunow M (1995) Induction of immediate-early genes and the control of neurotransmitter-regulated gene expression within the nervous system. *Pharmacol Rev* 47:133-178.
- Huwylar J, Pardridge WM (1998) Examination of blood-brain barrier transferrin receptor by confocal fluorescent microscopy of unfixed isolated rat brain capillaries. *J Neurochem* 70:883-886.
- Imaizumi M, Takeda M, Fushiki T. (2000) Effects of oil intake in the conditioned place preference test in mice. *Brain Res.* 870(1-2):150-6.
- Jalabert M, Aston-Jones G, Herzog E, Manzoni O, Georges F (2009) Role of the bed nucleus of the stria terminalis in the control of ventral tegmental area dopamine neurons. *Prog Neuropsychopharmacol Biol Psychiatry* 33:1336-1346.
- Jay TM (2003) Dopamine: a potential substrate for synaptic plasticity and memory mechanisms. *Prog Neurobiol* 69:375-390.
- Jennings JH, Sparta DR, Stamatakis AM, Ung RL, Pleil KE, Kash TL, Stuber GD (2013) Distinct extended amygdala circuits for divergent motivational states. *Nature* 496:224-228.
- Jensen ML, Wafford KA, Brown AR, Belelli D, Lambert JJ, Mirza NR (2013) A study of subunit selectivity, mechanism and site of action of the δ selective compound 2 (DS2) at human recombinant and rodent native GABA_A receptors. *Br J Pharmacol* 168:1118-1132.
- Jhou TC, Fields HL, Baxter MG, Saper CB, Holland PC (2009) The rostromedial tegmental nucleus (RMTg), a GABAergic afferent to midbrain dopamine neurons, encodes aversive stimuli and inhibits motor responses. *Neuron* 61:786-800.
- Jia F, Goldstein PA, Harrison NL (2009) The modulation of synaptic GABA_A receptors in the thalamus by eszopiclone and zolpidem. *J Pharmacol Exp Ther* 328:1000-1006.
- Jin P, Walther D, Zhang J, Rowe-Teeter C, Fu GK (2004) Serine 171, a conserved residue in the γ -aminobutyric acid type A (GABA_A) receptor γ 2 subunit, mediates subunit interaction and cell surface localization. *J Biol Chem* 279:14179-14183.
- Jin Z, Mendu SK, Birnir B (2013) GABA is an effective immunomodulatory molecule. *Amino Acids* 45:87-94.
- Jones S, Kornblum JL, Kauer JA (2000) Amphetamine blocks long-term synaptic depression in the ventral tegmental area. *J Neurosci* 20:5575-5580.
- Kaila K, Lamsa K, Smirnov S, Taira T, Voipio J (1997) Long-lasting GABA-mediated depolarization evoked by high-frequency stimulation in pyramidal neurons of rat hippocampal slice is attributable to a network-driven, bicarbonate-dependent K⁺ transient. *J Neurosci* 17:7662-7672.
- Kalivas PW, Churchill L, Klitenick MA (1993) GABA and enkephalin projection from the nucleus accumbens and ventral pallidum to the ventral tegmental area. *Neuroscience* 57:1047-1060.
- Kalivas PW, Duffy P, Eberhardt H (1990) Modulation of A10 dopamine neurons by γ -aminobutyric acid agonists. *J Pharmacol Exp Ther* 253:858-866.
- Kaneda M, Farrant M, Cull-Candy SG (1995) Whole-cell and single-channel currents activated by GABA and glycine in granule cells of the rat cerebellum. *J Physiol* 485 (Pt 2):419-435.
- Kasper S, Ebert B, Larsen K, Tonnoir B (2012) Combining escitalopram with gaboxadol provides no additional benefit in the treatment of patients with severe major depressive disorder. *Int J Neuropsychopharmacol* 15:715-725.
- Kauer JA, Malenka RC (2007) Synaptic plasticity and addiction. *Nat Rev Neurosci* 8:844-858.

- Kempadoo KA, Tourino C, Cho SL, Magnani F, Leininger GM, Stuber GD, Zhang F, Myers MG, Deisseroth K, de Lecea L, Bonci A (2013) Hypothalamic neurotensin projections promote reward by enhancing glutamate transmission in the VTA. *J Neurosci* 33:7618-7626.
- Kennedy RT, Thompson JE, Vickroy TW (2002) In vivo monitoring of amino acids by direct sampling of brain extracellular fluid at ultralow flow rates and capillary electrophoresis. *J Neurosci Methods* 114:39-49.
- Kim SY, Adhikari A, Lee SY, Marshel JH, Kim CK, Mallory CS, Lo M, Pak S, Mattis J, Lim BK, Malenka RC, Warden MR, Neve R, Tye KM, Deisseroth K (2013) Diverging neural pathways assemble a behavioural state from separable features in anxiety. *Nature* 496:219-223.
- Kirby LG, Zeeb FD, Winstanley CA (2011) Contributions of serotonin in addiction vulnerability. *Neuropharmacology* 61:421-432.
- Kirkness EF, Fraser CM (1993) A strong promoter element is located between alternative exons of a gene encoding the human γ -aminobutyric acid-type A receptor β 3 subunit (GABRB3). *J Biol Chem* 268:4420-4428.
- Klausberger T, Somogyi P (2008) Neuronal diversity and temporal dynamics: the unity of hippocampal circuit operations. *Science* 321:53-57.
- Koob GF, Le Moal M. (2001) Drug addiction, dysregulation of reward, and allostasis. *Neuropsychopharmacology*; 24(2):97-129.
- Korpi ER, Debus F, Linden AM, Malecot C, Leppa E, Vekovischeva O, Rabe H, Bohme I, Aller MI, Wisden W, Lüddens H (2007) Does ethanol act preferentially via selected brain GABA_A receptor subtypes the current evidence is ambiguous. *Alcohol* 41:163-176.
- Korpi ER, Grunder G, Lüddens H (2002) Drug interactions at GABA_A receptors. *Prog Neurobiol* 67:113-159.
- Korpi ER, Kuner T, Kristo P, Kohler M, Herb A, Lüddens H, Seeburg PH (1994) Small N-terminal deletion by splicing in cerebellar α 6 subunit abolishes GABA_A receptor function. *J Neurochem* 63:1167-1170.
- Korpi ER, Mihalek RM, Sinkkonen ST, Hauer B, Hevers W, Homanics GE, Sieghart W, Lüddens H (2002) Altered receptor subtypes in the forebrain of GABA_A receptor δ subunit-deficient mice: recruitment of γ 2 subunits. *Neuroscience* 109:733-743.
- Korpi ER, Seeburg PH, Lüddens H (1996) Modulation of GABA_A receptor tert-[35S]butylbicyclophosphorothionate binding by antagonists: relationship to patterns of subunit expression. *J Neurochem* 66:2179-2187.
- Kovacs KJ (1998) c-Fos as a transcription factor: a stressful (re)view from a functional map. *Neurochem Int* 33:287-297.
- Kramer PF, Christensen CH, Hazelwood LA, Dobi A, Bock R, Sibley DR, Mateo Y, Alvarez VA (2011) Dopamine D2 receptor overexpression alters behavior and physiology in *Drd2-EGFP* mice. *J Neurosci* 31:126-132.
- Krogsgaard-Larsen P, Frolund B, Liljefors T, Ebert B (2004) GABA_A agonists and partial agonists: THIP (Gaboxadol) as a non-opioid analgesic and a novel type of hypnotic. *Biochem Pharmacol* 68:1573-1580.
- Krogsgaard-Larsen P, Hjeds H, Curtis DR, Lodge D, Johnston GA (1979) Dihydromuscimol, thiomuscimol and related heterocyclic compounds as GABA analogues. *J Neurochem* 32:1717-1724.
- Kuzmin A, Johansson B (2000) Reinforcing and neurochemical effects of cocaine: differences among C57, DBA, and 129 mice. *Pharmacol Biochem Behav* 65:399-406.
- Kuzmin AV, Zvartau EE (1991) The intravenous self-administration of narcotics in mice]. *Zh Vyssh Nerv Deiat Im I P Pavlova* 41:1253-1260.
- Kuzmin AV, Patkina NA, Zvartau EE (1994) Analgesic and reinforcing effects of morphine in mice. Influence of Bay K-8644 and nimodipine. *Brain Res* 652:1-8.
- Lalive AL, Rudolph U, Luscher C, Tan KR (2011) Is there a way to curb benzodiazepine addiction? *Swiss Med Wkly* 141:w13277.

- Lankford DA, Corser BC, Zheng YP, Li Z, Snavely DB, Lines CR, Deacon S. (2008) Effect of gaboxadol on sleep in adult and elderly patients with primary insomnia: results from two randomized, placebo-controlled, 30-night polysomnography studies. *Sleep* 31(10):1359-70.
- Lambert JJ, Cooper MA, Simmons RD, Weir CJ, Belelli D (2009) Neurosteroids: endogenous allosteric modulators of GABA_A receptors. *Psychoneuroendocrinology* 34 Suppl 1:S48-58.
- Lammel S, Ion DI, Roeper J, Malenka RC (2011) Projection-specific modulation of dopamine neuron synapses by aversive and rewarding stimuli. *Neuron* 70:855-862.
- Lammel S, Lim BK, Malenka RC (2013) Reward and aversion in a heterogeneous midbrain dopamine system. *Neuropharmacology*
- Lammel S, Lim BK, Ran C, Huang KW, Betley MJ, Tye KM, Deisseroth K, Malenka RC (2012) Input-specific control of reward and aversion in the ventral tegmental area. *Nature* 491:212-217.
- Larsen M, Holm R, Jensen KG, Brodin B, Nielsen CU (2009) Intestinal gaboxadol absorption via PAT1 (SLC36A1): modified absorption in vivo following co-administration of L-tryptophan. *Br J Pharmacol* 157:1380-1389.
- Larsen M, Holm R, Jensen KG, Sveigaard C, Brodin B, Nielsen CU (2010) 5-Hydroxy-L-tryptophan alters gaboxadol pharmacokinetics in rats: involvement of PAT1 and rOat1 in gaboxadol absorption and elimination. *Eur J Pharm Sci* 39:68-75.
- Laurie DJ, Wisden W, Seeburg PH (1992) The distribution of thirteen GABA_A receptor subunit mRNAs in the rat brain. III. Embryonic and postnatal development. *J Neurosci* 12:4151-4172.
- Lee S, Yoon BE, Berglund K, Oh SJ, Park H, Shin HS, Augustine GJ, Lee CJ (2010) Channel-mediated tonic GABA release from glia. *Science* 330:790-796.
- Leite JF, Cascio M (2001) Structure of ligand-gated ion channels: critical assessment of biochemical data supports novel topology. *Mol Cell Neurosci* 17:777-792.
- Lewis RW, Mabry J, Polisar JG, Eagen KP, Ganem B, Hess GP (2010) Dihydropyrimidinone positive modulation of δ -subunit-containing γ -aminobutyric acid type A receptors, including an epilepsy-linked mutant variant. *Biochemistry* 49:4841-4851.
- Li C, McCall NM, Lopez AJ, Kash TL (2013) Alcohol effects on synaptic transmission in periaqueductal gray dopamine neurons. *Alcohol* 47:279-287.
- Linden AM, Schmitt U, Leppa E, Wulff P, Wisden W, Lüddens H, Korpi ER (2011) Ro 15-4513 Antagonizes Alcohol-Induced Sedation in Mice Through $\alpha\beta\gamma 2$ -type GABA_A Receptors. *Front Neurosci* 5:3.
- Link W, Konietzko U, Kauselmann G, Krug M, Schwanke B, Frey U, Kuhl D (1995) Somatodendritic expression of an immediate early gene is regulated by synaptic activity. *Proc Natl Acad Sci U S A* 92:5734-5738.
- Liu QY, Schaffner AE, Chang YH, Maric D, Barker JL (2000) Persistent activation of GABA_A receptor/Cl⁻ channels by astrocyte-derived GABA in cultured embryonic rat hippocampal neurons. *J Neurophysiol* 84:1392-1403.
- Lodge DJ, Grace AA (2006) The laterodorsal tegmentum is essential for burst firing of ventral tegmental area dopamine neurons. *Proc Natl Acad Sci U S A* 103:5167-5172.
- LoTurco JJ, Owens DF, Heath MJ, Davis MB, Kriegstein AR (1995) GABA and glutamate depolarize cortical progenitor cells and inhibit DNA synthesis. *Neuron* 15:1287-1298.
- Lu J, Greco MA (2006) Sleep circuitry and the hypnotic mechanism of GABA_A drugs. *J Clin Sleep Med* 2:S19-26.
- Lüddens H, Korpi ER (1995) GABA antagonists differentiate between recombinant GABA_A/benzodiazepine receptor subtypes. *J Neurosci* 15:6957-6962.
- Lummis SC, Nicoletti G, Johnston GA, Holan G (1991) Γ -aminobutyric acid-modulated benzodiazepine binding sites in bacteria. *Life Sci* 49:1079-1086.
- Luscher C, Malenka RC (2011) Drug-evoked synaptic plasticity in addiction: from molecular changes to circuit remodeling. *Neuron* 69:650-663.

- Macdonald RL, Kang JQ, Gallagher MJ (2010) Mutations in GABA_A receptor subunits associated with genetic epilepsies. *J Physiol* 588:1861-1869.
- Maguire J, Mody I (2007) Neurosteroid synthesis-mediated regulation of GABA_A receptors: relevance to the ovarian cycle and stress. *J Neurosci* 27:2155-2162.
- Maguire J, Mody I (2007) Neurosteroid synthesis-mediated regulation of GABA_A receptors: relevance to the ovarian cycle and stress. *J Neurosci* 27:2155-2162.
- Maguire JL, Stell BM, Rafizadeh M, Mody I (2005) Ovarian cycle-linked changes in GABA_A receptors mediating tonic inhibition alter seizure susceptibility and anxiety. *Nat Neurosci* 8:797-804.
- Malenka RC, Bear MF (2004) LTP and LTD: an embarrassment of riches. *Neuron* 44:5-21.
- Mallart A, Martin AR (1968) The relation between quantum content and facilitation at the neuromuscular junction of the frog. *J Physiol* 196:593-604.
- Mameli M, Balland B, Lujan R, Luscher C (2007) Rapid synthesis and synaptic insertion of GluR2 for mGluR-LTD in the ventral tegmental area. *Science* 317:530-533.
- Mameli M, Halbout B, Creton C, Engblom D, Parkitna JR, Spanagel R, Luscher C (2009) Cocaine-evoked synaptic plasticity: persistence in the VTA triggers adaptations in the NAc. *Nat Neurosci* 12:1036-1041.
- Maren S, Fanselow MS (1995) Synaptic plasticity in the basolateral amygdala induced by hippocampal formation stimulation in vivo. *J Neurosci* 15:7548-7564.
- Margolis EB, Lock H, Hjelmstad GO, Fields HL (2006) The ventral tegmental area revisited: is there an electrophysiological marker for dopaminergic neurons? *J Physiol* 577:907-924.
- Margolis EB, Mitchell JM, Ishikawa J, Hjelmstad GO, Fields HL (2008) Midbrain dopamine neurons: projection target determines action potential duration and dopamine D(2) receptor inhibition. *J Neurosci* 28:8908-8913.
- Margolis EB, Toy B, Himmels P, Morales M, Fields HL (2012) Identification of rat ventral tegmental area GABAergic neurons. *PLoS One* 7:e42365.
- Marowsky A, Rudolph U, Fritschy JM, Arand M (2012) Tonic inhibition in principal cells of the amygdala: a central role for $\alpha 3$ subunit-containing GABA_A receptors. *J Neurosci* 32:8611-8619.
- Martellotta MC, Kuzmin A, Zvartau E, Cossu G, Gessa GL, Fratta W (1995) Isradipine inhibits nicotine intravenous self-administration in drug-naive mice. *Pharmacol Biochem Behav* 52:271-274.
- Martyniuk CJ, Aris-Brosou S, Drouin G, Cahn J, Rudeau VL (2007) Early evolution of ionotropic GABA receptors and selective regimes acting on the mammalian-specific theta and epsilon subunits. *PLoS One* 2:e894.
- Marx CE, Stevens RD, Shampine LJ, Uzunova V, Trost WT, Butterfield MI, Massing MW, Hamer RM, Morrow AL, Lieberman JA (2006) Neuroactive steroids are altered in schizophrenia and bipolar disorder: relevance to pathophysiology and therapeutics. *Neuropsychopharmacology* 31:1249-1263.
- Mathias S, Zihl J, Steiger A, Lancel M. (2005) Effect of repeated gaboxadol administration on night sleep and next-day performance in healthy elderly subjects. *Neuropsychopharmacology*: 30(4):833-41.
- Mathon DS, Kamal A, Smidt MP, Ramakers GM (2003) Modulation of cellular activity and synaptic transmission in the ventral tegmental area. *Eur J Pharmacol* 480:97-115.
- Matsumoto M, Hikosaka O (2009) Two types of dopamine neuron distinctly convey positive and negative motivational signals. *Nature* 459:837-841.
- McKernan RM, Whiting PJ (1996) Which GABA_A-receptor subtypes really occur in the brain? *Trends Neurosci* 19:139-143.
- Meera P, Wallner M, Otis TS (2011) Molecular basis for the high THIP/gaboxadol sensitivity of extrasynaptic GABA_A receptors. *J Neurophysiol* 106:2057-2064.
- Melcangi RC, Magnaghi V, Galbiati M, Martini L (2001) Formation and effects of neuroactive steroids in the central and peripheral nervous system. *Int Rev Neurobiol* 46:145-176.

- Melis M, Camarini R, Ungless MA, Bonci A (2002) Long-lasting potentiation of GABAergic synapses in dopamine neurons after a single in vivo ethanol exposure. *J Neurosci* 22:2074-2082.
- Meloni EG, Gerety LP, Knoll AT, Cohen BM, Carlezon WA, Jr (2006) Behavioral and anatomical interactions between dopamine and corticotropin-releasing factor in the rat. *J Neurosci* 26:3855-3863.
- Mendu SK, Akesson L, Jin Z, Edlund A, Cilio C, Lernmark A, Birnir B (2011) Increased GABA_A channel subunits expression in CD8(+) but not in CD4(+) T cells in BB rats developing diabetes compared to their congenic littermates. *Mol Immunol* 48:399-407.
- Mihalek RM, Banerjee PK, Korpi ER, Quinlan JJ, Firestone LL, Mi ZP, Lagenaur C, Tretter V, Sieghart W, Anagnostaras SG, Sage JR, Fanselow MS, Guidotti A, Spigelman I, Li Z, DeLorey TM, Olsen RW, Homanics GE (1999) Attenuated sensitivity to neuroactive steroids in γ -aminobutyrate type A receptor δ subunit knockout mice. *Proc Natl Acad Sci U S A* 96:12905-12910.
- Mihalek RM, Bowers BJ, Wehner JM, Kralic JE, VanDoren MJ, Morrow AL, Homanics GE (2001) GABA_A-receptor δ subunit knockout mice have multiple defects in behavioral responses to ethanol. *Alcohol Clin Exp Res* 25:1708-1718.
- Mody I, Pearce RA (2004) Diversity of inhibitory neurotransmission through GABA_A receptors. *Trends Neurosci* 27:569-575.
- Naik SR, Guidotti A, Costa E (1976) Central GABA receptor agonists: comparison of muscimol and baclofen. *Neuropharmacology* 15:479-484.
- Nair-Roberts RG, Chatelain-Badie SD, Benson E, White-Cooper H, Bolam JP, Ungless MA (2008) Stereological estimates of dopaminergic, GABAergic and glutamatergic neurons in the ventral tegmental area, substantia nigra and retrorubral field in the rat. *Neuroscience* 152:1024-1031.
- Nakamura T, Uramura K, Nambu T, Yada T, Goto K, Yanagisawa M, Sakurai T (2000) Orexin-induced hyperlocomotion and stereotypy are mediated by the dopaminergic system. *Brain Res* 873:181-187.
- Nestler EJ. (2005) Is there a common molecular pathway for addiction? *Nat Neurosci*. 8(11):1445-9.
- Nie H, Rewal M, Gill TM, Ron D, Janak PH (2011) Extrasynaptic δ -containing GABA_A receptors in the nucleus accumbens dorsomedial shell contribute to alcohol intake. *Proc Natl Acad Sci U S A* 108:4459-4464.
- Niehaus JL, Murali M, Kauer JA (2010) Drugs of abuse and stress impair LTP at inhibitory synapses in the ventral tegmental area. *Eur J Neurosci* 32:108-117.
- Nielsen CU, Frolund S, Abdulhadi S, Sari H, Langthaler L, Nohr MK, Kall MA, Brodin B, Holm R (2013) Sertraline inhibits transport of PAT1 substrates in vivo and in vitro. *Br J Pharmacol*
- Nohria V, Giller E (2007) Ganaxolone. *Neurotherapeutics* 4:102-105.
- Nugent FS, Kauer JA (2008) LTP of GABAergic synapses in the ventral tegmental area and beyond. *J Physiol* 586:1487-1493.
- Nugent FS, Penick EC, Kauer JA (2007) Opioids block long-term potentiation of inhibitory synapses. *Nature* 446:1086-1090.
- Nusser Z, Mody I (2002) Selective modulation of tonic and phasic inhibitions in dentate gyrus granule cells. *J Neurophysiol* 87:2624-2628.
- Okada H, Matsushita N, Kobayashi K, Kobayashi K (2004) Identification of GABA_A receptor subunit variants in midbrain dopaminergic neurons. *J Neurochem* 89:7-14.
- Olds J, Milner P (1954) Positive reinforcement produced by electrical stimulation of septal area and other regions of rat brain. *J Comp Physiol Psychol* 47:419-427.
- Olmos-Serrano JL, Corbin JG, Burns MP (2011) The GABA_A receptor agonist THIP ameliorates specific behavioral deficits in the mouse model of fragile X syndrome. *Dev Neurosci* 33:395-403.
- Olmos-Serrano JL, Paluszkiwicz SM, Martin BS, Kaufmann WE, Corbin JG, Huntsman MM (2010) Defective GABAergic neurotransmission and pharmacological rescue of

- neuronal hyperexcitability in the amygdala in a mouse model of fragile X syndrome. *J Neurosci* 30:9929-9938.
- Olsen RW, Sieghart W (2009) GABA_A receptors: subtypes provide diversity of function and pharmacology. *Neuropharmacology* 56:141-148.
- Olesen J, Gustavsson A, Svensson M, Wittchen HU, Jonsson B, CDBE2010 study group; European Brain Council (2012). The economic cost of brain disorders in Europe. *Eur J Neurol* 19: 155-162.
- Omelchenko N, Sesack SR (2006) Cholinergic axons in the rat ventral tegmental area synapse preferentially onto mesoaccumbens dopamine neurons. *J Comp Neurol* 494:863-875.
- Ortells MO, Lunt GG (1995) Evolutionary history of the ligand-gated ion-channel superfamily of receptors. *Trends Neurosci* 18:121-127.
- Overstreet LS, Westbrook GL (2001) Paradoxical reduction of synaptic inhibition by vigabatrin. *J Neurophysiol* 86:596-603.
- Panhelainen AE, Korpi ER (2012) Evidence for a role of inhibition of orexinergic neurons in the anxiolytic and sedative effects of diazepam: A c-Fos study. *Pharmacol Biochem Behav* 101:115-124.
- Panhelainen AE, Vekovischeva OY, Aitta-Aho T, Rasanen I, Ojanpera I, Korpi ER (2011) Diazepam-induced neuronal plasticity attenuates locomotor responses to morphine and amphetamine challenges in mice. *Neuroscience* 192:312-321.
- Parsons LH, Justice JB, Jr (1992) Extracellular concentration and in vivo recovery of dopamine in the nucleus accumbens using microdialysis. *J Neurochem* 58:212-218.
- Peng HY, Chen GD, Lee SD, Lai CY, Chiu CH, Cheng CL, Chang YS, Hsieh MC, Tung KC, Lin TB (2009) Neuroactive steroids inhibit spinal reflex potentiation by selectively enhancing specific spinal GABA_A receptor subtypes. *Pain* 143:12-20.
- Peng Z, Hauer B, Mihalek RM, Homanics GE, Sieghart W, Olsen RW, Houser CR (2002) GABA_A receptor changes in δ subunit-deficient mice: altered expression of $\alpha 4$ and $\gamma 2$ subunits in the forebrain. *J Comp Neurol* 446:179-197.
- Perovic S, Krasko A, Prokic I, Muller IM, Muller WE (1999) Origin of neuronal-like receptors in Metazoa: cloning of a metabotropic glutamate/GABA-like receptor from the marine sponge *Geodia cydonium*. *Cell Tissue Res* 296:395-404.
- Phillips AG, Fibiger HC (1978) The role of dopamine in maintaining intracranial self-stimulation in the ventral tegmentum, nucleus accumbens, and medial prefrontal cortex. *Can J Psychol* 32:58-66.
- Pibiri F, Nelson M, Guidotti A, Costa E, Pinna G (2008) Decreased corticolimbic allopregnanolone expression during social isolation enhances contextual fear: A model relevant for posttraumatic stress disorder. *Proc Natl Acad Sci U S A* 105:5567-5572.
- Pieribone VA, Tsai J, Soufflet C, Rey E, Shaw K, Giller E, Dulac O (2007) Clinical evaluation of ganaxolone in pediatric and adolescent patients with refractory epilepsy. *Epilepsia* 48:1870-1874.
- Pirker S, Schwarzer C, Wieselthaler A, Sieghart W, Sperk G (2000) GABA_A receptors: immunocytochemical distribution of 13 subunits in the adult rat brain. *Neuroscience* 101:815-850.
- Porcello DM, Huntsman MM, Mihalek RM, Homanics GE, Huguenard JR (2003) Intact synaptic GABAergic inhibition and altered neurosteroid modulation of thalamic relay neurons in mice lacking δ subunit. *J Neurophysiol* 89:1378-1386.
- Prenosil GA, Schneider Gasser EM, Rudolph U, Keist R, Fritschy JM, Vogt KE (2006) Specific subtypes of GABA_A receptors mediate phasic and tonic forms of inhibition in hippocampal pyramidal neurons. *J Neurophysiol* 96:846-857.
- Procaccini C, Aitta-aho T, Jaako-Movits K, Zharkovsky A, Panhelainen A, Sprengel R, Linden AM, Korpi ER (2011) Excessive novelty-induced c-Fos expression and altered neurogenesis in the hippocampus of GluA1 knockout mice. *Eur J Neurosci* 33:161-174.
- Ramaker MJ, Ford MM, Fretwell AM, Finn DA (2011) Alteration of ethanol drinking in mice via modulation of the GABA_A receptor with ganaxolone, finasteride, and gaboxadol. *Alcohol Clin Exp Res* 35:1994-2007.

- Ramaker MJ, Strong MN, Ford MM, Finn DA (2012) Effect of ganaxolone and THIP on operant and limited-access ethanol self-administration. *Neuropharmacology* 63:555-564.
- Reddy DS (2013) Role of hormones and neurosteroids in epileptogenesis. *Front Cell Neurosci* 7:115.
- Reddy DS, Rogawski MA (2009) Neurosteroid replacement therapy for catamenial epilepsy. *Neurotherapeutics* 6:392-401.
- Rewal M, Jurd R, Gill TM, He DY, Ron D, Janak PH (2009) A4-containing GABA_A receptors in the nucleus accumbens mediate moderate intake of alcohol. *J Neurosci* 29:543-549.
- Rivera C, Voipio J, Payne JA, Ruusuvuori E, Lahtinen H, Lamsa K, Pirvola U, Saarma M, Kaila K (1999) The K⁺/Cl⁻ co-transporter KCC2 renders GABA hyperpolarizing during neuronal maturation. *Nature* 397:251-255.
- Robel P, Young J, Corpechot C, Mayo W, Perche F, Haug M, Simon H, Baulieu EE (1995) Biosynthesis and assay of neurosteroids in rats and mice: functional correlates. *J Steroid Biochem Mol Biol* 53:355-360.
- Rosin DL, Weston MC, Sevigny CP, Stornetta RL, Guyenet PG (2003) Hypothalamic orexin (hypocretin) neurons express vesicular glutamate transporters VGLUT1 or VGLUT2. *J Comp Neurol* 465:593-603.
- Rossi DJ, Hamann M, Attwell D (2003) Multiple modes of GABAergic inhibition of rat cerebellar granule cells. *J Physiol* 548:97-110.
- Roth T, Lines C, Vandormael K, Ceesay P, Anderson D, Snavely D (2010) Effect of gaboxadol on patient-reported measures of sleep and waking function in patients with Primary Insomnia: results from two randomized, controlled, 3-month studies. *J Clin Sleep Med* 6:30-39.
- Rouge-Pont F, Mayo W, Marinelli M, Gingras M, Le Moal M, Piazza PV (2002) The neurosteroid allopregnanolone increases dopamine release and dopaminergic response to morphine in the rat nucleus accumbens. *Eur J Neurosci* 16:169-173.
- Rudolph U, Mohler H (2004) Analysis of GABA_A receptor function and dissection of the pharmacology of benzodiazepines and general anesthetics through mouse genetics. *Annu Rev Pharmacol Toxicol* 44:475-498.
- Ryan TJ, Grant SG (2009) The origin and evolution of synapses. *Nat Rev Neurosci* 10:701-712.
- Saal D, Dong Y, Bonci A, Malenka RC (2003) Drugs of abuse and stress trigger a common synaptic adaptation in dopamine neurons. *Neuron* 37:577-582.
- Saarelainen KS, Ranna M, Rabe H, Sinkkonen ST, Moykkynen T, Uusi-Oukari M, Linden AM, Lüddens H, Korpi ER (2008) Enhanced behavioral sensitivity to the competitive GABA agonist, gaboxadol, in transgenic mice over-expressing hippocampal extrasynaptic $\alpha\beta$ GABA_A receptors. *J Neurochem* 105:338-350.
- Sakmann B, Neher E (1984) Patch clamp techniques for studying ionic channels in excitable membranes. *Annu Rev Physiol* 46:455-472.
- Salin PA, Prince DA (1996) Electrophysiological mapping of GABA_A receptor-mediated inhibition in adult rat somatosensory cortex. *J Neurophysiol* 75:1589-1600.
- Santhakumar V, Jones RT, Mody I (2010) Developmental regulation and neuroprotective effects of striatal tonic GABA_A currents. *Neuroscience* 167:644-655.
- Sara SJ (2009) The locus coeruleus and noradrenergic modulation of cognition. *Nat Rev Neurosci* 10:211-223.
- Sarti F, Borgland SL, Kharazia VN, Bonci A (2007) Acute cocaine exposure alters spine density and long-term potentiation in the ventral tegmental area. *Eur J Neurosci* 26:749-756.
- Schoedel K, Rosen L, Alexander R (2009) A single-dose randomized, double-blind, crossover abuse liability study to evaluate the subjective and objective effects of gaboxadol and zolpidem in recreational drug users. 85(Suppl 1):S22:Abstract PI-44.
- Schultz W (2013) Updating dopamine reward signals. *Curr Opin Neurobiol* 23:229-238.

- Schultz W (2007) Multiple dopamine functions at different time courses. *Annu Rev Neurosci* 30:259-288.
- Schultz W, Dayan P, Montague PR (1997) A neural substrate of prediction and reward. *Science* 275:1593-1599.
- Semyanov A, Walker MC, Kullmann DM (2003) GABA uptake regulates cortical excitability via cell type-specific tonic inhibition. *Nat Neurosci* 6:484-490.
- Serwanski DR, Miralles CP, Christie SB, Mehta AK, Li X, De Blas AL (2006) Synaptic and nonsynaptic localization of GABA_A receptors containing the $\alpha 5$ subunit in the rat brain. *J Comp Neurol* 499:458-470.
- Shen H, Gong QH, Yuan M, Smith SS (2005) Short-term steroid treatment increases δ GABA_A receptor subunit expression in rat CA1 hippocampus: pharmacological and behavioral effects. *Neuropharmacology* 49:573-586.
- Shen H, Sabaliauskas N, Sherpa A, Fenton AA, Stelzer A, Aoki C, Smith SS (2010) A critical role for $\alpha 4\beta\delta$ GABA_A receptors in shaping learning deficits at puberty in mice. *Science* 327:1515-1518.
- Sigel E, Luscher BP (2011) A closer look at the high affinity benzodiazepine binding site on GABA_A receptors. *Curr Top Med Chem* 11:241-246.
- Simon J, Wakimoto H, Fujita N, Lalande M, Barnard EA. (2004) Analysis of the set of GABA_A receptor genes in the human genome. *J Biol Chem*. 279(40):41422-35. Epub 2004 Jul 16.
- Skolnick P (2013) Response to W. Sieghart. *Trends Pharmacol Sci* 34:146.
- Smith BR, Robidoux J, Amit Z (1992) GABAergic involvement in the acquisition of voluntary ethanol intake in laboratory rats. *Alcohol Alcohol* 27:227-231.
- Smith CG, Bowery NG, Whitehead KJ (2007) GABA transporter type 1 (GAT-1) uptake inhibition reduces stimulated aspartate and glutamate release in the dorsal spinal cord in vivo via different GABAergic mechanisms. *Neuropharmacology* 53:975-981.
- Sommer B, Poustka A, Spurr NK, Seeburg PH (1990) The murine GABA_A receptor δ -subunit gene: structure and assignment to human chromosome 1. *DNA Cell Biol* 9:561-568.
- Song M, Wang XY, Zhao M, Wang XY, Zhai HF, Lu L (2007) Role of stress in acquisition of alcohol-conditioned place preference in adolescent and adult mice. *Alcohol Clin Exp Res* 31:2001-2005.
- Sparta DR, Jennings JH, Ung RL, Stuber GD (2013) Optogenetic strategies to investigate neural circuitry engaged by stress. *Behav Brain Res*
- Spigelman I, Li Z, Liang J, Cagetti E, Samzadeh S, Mihalek RM, Homanics GE, Olsen RW (2003) Reduced inhibition and sensitivity to neurosteroids in hippocampus of mice lacking the GABA_A receptor δ subunit. *J Neurophysiol* 90:903-910.
- Stamatakis AM, Stuber GD (2012) Activation of lateral habenula inputs to the ventral midbrain promotes behavioral avoidance. *Nat Neurosci* 15:1105-1107.
- Storustovu SI, Ebert B (2006) Pharmacological characterization of agonists at δ -containing GABA_A receptors: Functional selectivity for extrasynaptic receptors is dependent on the absence of $\gamma 2$. *J Pharmacol Exp Ther* 316:1351-1359.
- Stuber GD, Klanker M, de Ridder B, Bowers MS, Joosten RN, Feenstra MG, Bonci A (2008) Reward-predictive cues enhance excitatory synaptic strength onto midbrain dopamine neurons. *Science* 321:1690-1692.
- Svarnik OE, Alexandrov YI, Gavrilov VV, Grinchenko YV, Anokhin KV (2005) Fos expression and task-related neuronal activity in rat cerebral cortex after instrumental learning. *Neuroscience* 136:33-42.
- Swanson LW (1982) The projections of the ventral tegmental area and adjacent regions: a combined fluorescent retrograde tracer and immunofluorescence study in the rat. *Brain Res Bull* 9:321-353.
- Tamamaki N, Yanagawa Y, Tomioka R, Miyazaki J, Obata K, Kaneko T (2003) Green fluorescent protein expression and colocalization with calretinin, parvalbumin, and somatostatin in the GAD67-GFP knock-in mouse. *J Comp Neurol* 467:60-79.

- Tan KR, Brown M, Labouebe G, Yvon C, Creton C, Fritschy JM, Rudolph U, Luscher C (2010) Neural bases for addictive properties of benzodiazepines. *Nature* 463:769-774.
- Thierry AM, Deniau JM, Feger J (1979) Effects of stimulation of the frontal cortex on identified output VMT cells in the rat. *Neurosci Lett* 15:102-107.
- Thomas MJ, Malenka RC, Bonci A (2000) Modulation of long-term depression by dopamine in the mesolimbic system. *J Neurosci* 20:5581-5586.
- Tossman U, Jonsson G, Ungerstedt U (1986) Regional distribution and extracellular levels of amino acids in rat central nervous system. *Acta Physiol Scand* 127:533-545.
- Tritsch NX, Ding JB, Sabatini BL (2012) Dopaminergic neurons inhibit striatal output through non-canonical release of GABA. *Nature* 490:262-266.
- Ungless MA, Argilli E, Bonci A (2010) Effects of stress and aversion on dopamine neurons: implications for addiction. *Neurosci Biobehav Rev* 35:151-156.
- Ungless MA, Whistler JL, Malenka RC, Bonci A (2001) Single cocaine exposure in vivo induces long-term potentiation in dopamine neurons. *Nature* 411:583-587.
- Uusi-Oukari M, Korpi ER (2010) Regulation of GABA_A receptor subunit expression by pharmacological agents. *Pharmacol Rev* 62:97-135.
- Valenti O, Lodge DJ, Grace AA (2011) Aversive stimuli alter ventral tegmental area dopamine neuron activity via a common action in the ventral hippocampus. *J Neurosci* 31:4280-4289.
- Van Bockstaele EJ, Pickel VM (1995) GABA-containing neurons in the ventral tegmental area project to the nucleus accumbens in rat brain. *Brain Res* 682:215-221.
- van Rijn RM, Brissett DI, Whistler JL (2010) Dual efficacy of δ opioid receptor-selective ligands for ethanol drinking and anxiety. *J Pharmacol Exp Ther* 335:133-139.
- Vardya I, Drasbek KR, Dosa Z, Jensen K (2008) Cell type-specific GABA_A receptor-mediated tonic inhibition in mouse neocortex. *J Neurophysiol* 100:526-532.
- Vardya I, Hoestgaard-Jensen K, Nieto-Gonzalez JL, Dosa Z, Boddum K, Holm MM, Wolinsky TD, Jones KA, Dalby NO, Ebert B, Jensen K (2012) Positive modulation of δ -subunit containing GABA_A receptors in mouse neurons. *Neuropharmacology* 63:469-479.
- Vekovischeva OY, Peuhkuri K, Backstrom P, Sihvola N, Pilvi T, Korpela R (2013) The effects of native whey and α -lactalbumin on the social and individual behaviour of C57BL/6J mice. *Br J Nutr* 1-11.
- Venner A, Karnani MM, Gonzalez JA, Jensen LT, Fugger L, Burdakov D (2011) Orexin neurons as conditional glucosensors: paradoxical regulation of sugar sensing by intracellular fuels. *J Physiol* 589:5701-5708.
- Volkow ND, Fowler JS, Wang GJ (1999) Imaging studies on the role of dopamine in cocaine reinforcement and addiction in humans. *J Psychopharmacol* 13:337-345.
- Wafford KA, Ebert B (2006) Gaboxadol—a new awakening in sleep. *Curr Opin Pharmacol* 6:30-36.
- Wafford KA, van Niel MB, Ma QP, Horridge E, Herd MB, Peden DR, Belelli D, Lambert JJ (2009) Novel compounds selectively enhance δ subunit containing GABA_A receptors and increase tonic currents in thalamus. *Neuropharmacology* 56:182-189.
- Wagner DA, Goldschen-Ohm MP, Hales TG, Jones MV (2005) Kinetics and spontaneous open probability conferred by the epsilon subunit of the GABA_A receptor. *J Neurosci* 25:10462-10468.
- Walsh JK, Deacon S, Dijk DJ, Lundahl J. (2007) The selective extrasynaptic GABA_A agonist, gaboxadol, improves traditional hypnotic efficacy measures and enhances slow wave activity in a model of transient insomnia. *Sleep*: 30(5):593-602.
- Walker MC, Kullmann DM (2012) Tonic GABA_A Receptor-Mediated Signaling in Epilepsy. In: Jasper's Basic Mechanisms of the Epilepsies, 4th edition (Noebels JL, Avoli M, Rogawski MA, Olsen RW, Delgado-Escueta AV eds), Bethesda (MD): Michael A Rogawski, Antonio V Delgado-Escueta, Jeffrey L Noebels, Massimo Avoli and Richard W Olsen.

- Wallner M, Hancher HJ, Olsen RW (2003) Ethanol enhances $\alpha 4\beta 3\delta$ and $\alpha 6\beta 3\delta$ γ -aminobutyric acid type A receptors at low concentrations known to affect humans. *Proc Natl Acad Sci U S A* 100:15218-15223.
- Wanat MJ, Bonci A, Phillips PE (2013) CRF acts in the midbrain to attenuate accumbens dopamine release to rewards but not their predictors. *Nat Neurosci* 16:383-385.
- Wang DV, Tsien JZ (2011) Convergent processing of both positive and negative motivational signals by the VTA dopamine neuronal populations. *PLoS One* 6:e17047.
- Waszczak BL, Hruska RE, Walters JR (1980) GABAergic actions of THIP in vivo and vitro: a comparison with muscimol and GABA. *Eur J Pharmacol* 65:21-29.
- Watabe-Uchida M, Zhu L, Ogawa SK, Vamanrao A, Uchida N (2012) Whole-brain mapping of direct inputs to midbrain dopamine neurons. *Neuron* 74:858-873.
- Wiltgen BJ, Sanders MJ, Ferguson C, Homanics GE, Fanselow MS (2005) Trace fear conditioning is enhanced in mice lacking the δ subunit of the GABA_A receptor. *Learn Mem* 12:327-333.
- Windpassinger C, Kroisel PM, Wagner K, Petek E (2002) The human γ -aminobutyric acid A receptor δ (GABRD) gene: molecular characterisation and tissue-specific expression. *Gene* 292:25-31.
- Winsky-Sommerer R, Vyazovskiy VV, Homanics GE, Tobler I (2007) The EEG effects of THIP (Gaboxadol) on sleep and waking are mediated by the GABA_A δ -subunit-containing receptors. *Eur J Neurosci* 25:1893-1899.
- Wohlfarth KM, Bianchi MT, Macdonald RL (2002) Enhanced neurosteroid potentiation of ternary GABA_A receptors containing the δ subunit. *J Neurosci* 22:1541-1549.
- Volkow ND, Wang GJ, Fowler JS, Tomasi D. (2011) Addiction circuitry in the human brain. *Annu Rev Pharmacol Toxicol*.52:321-36.
- Wu Y, Wang W, Richerson GB (2006) The transmembrane sodium gradient influences ambient GABA concentration by altering the equilibrium of GABA transporters. *J Neurophysiol* 96:2425-2436.
- Xia Y, Driscoll JR, Wilbrecht L, Margolis EB, Fields HL, Hjelmstad GO (2011) Nucleus accumbens medium spiny neurons target non-dopaminergic neurons in the ventral tegmental area. *J Neurosci* 31:7811-7816.
- Xiao C, Zhou C, Li K, Ye JH (2007) Presynaptic GABA_A receptors facilitate GABAergic transmission to dopaminergic neurons in the ventral tegmental area of young rats. *J Physiol* 580:731-743.
- Yamaguchi T, Wang HL, Li X, Ng TH, Morales M (2011) Mesocorticolimbic glutamatergic pathway. *J Neurosci* 31:8476-8490.
- Yan J, He C, Xia JX, Zhang D, Hu ZA (2012) Orexin-A excites pyramidal neurons in layer 2/3 of the rat prefrontal cortex. *Neurosci Lett* 520:92-97.
- Yee BK, Hauser J, Dolgov VV, Keist R, Mohler H, Rudolph U, Feldon J (2004) GABA receptors containing the $\alpha 5$ subunit mediate the trace effect in aversive and appetitive conditioning and extinction of conditioned fear. *Eur J Neurosci* 20:1928-1936.
- Zweifel LS, Fadok JP, Argilli E, Garelick MG, Jones GL, Dickerson TM, Allen JM, Mizumori SJ, Bonci A, Palmiter RD (2011) Activation of dopamine neurons is critical for aversive conditioning and prevention of generalized anxiety. *Nat Neurosci* 14:620-626.