

Division of Pharmacology and Toxicology
Faculty of Pharmacy
University of Helsinki
Finland

**The DAG-responsive C1 domain as a drug target: structure-
activity and *in vitro* pharmacology of isophthalate derivatives**

Virpi Talman

ACADEMIC DISSERTATION

To be presented, with the permission of the Faculty of Pharmacy,
University of Helsinki, for public examination in auditorium 1041,
Viikki Biocenter 2, on November 22nd 2013, at 12 noon.

Supervisors Professor Raimo K. Tuominen
Division of Pharmacology and Toxicology
Faculty of Pharmacy
University of Helsinki
Finland

Dr Elina Ekokoski
Division of Pharmacology and Toxicology
Faculty of Pharmacy
University of Helsinki
Finland

Current address:
Finnish Safety and Chemicals Agency
Helsinki, Finland

Reviewers Professor Jyrki Kukkonen
Department of Veterinary Biosciences
Faculty of Veterinary Medicine
University of Helsinki
Finland

Adj. professor Päivi Koskinen
Department of Biology
University of Turku
Finland

Opponent Professor Kid Törnquist
Department of Biosciences/Cell Biology
Åbo Akademi University
Finland

© Virpi Talman
ISBN 978-952-10-9408-8 (paperback)
ISBN 978-952-10-9409-5 (PDF)
ISSN 1799-7372

Unigrafia - Helsinki University Print
Helsinki 2013

*“Research is the process of going up
alleys to see if they are blind.”*

- Marston Bates -

CONTENTS

1. INTRODUCTION	1
2. REVIEW OF THE LITERATURE	3
2.1 DIACYLGLYCEROL (DAG) SIGNALLING	3
2.2 PROTEIN KINASE C (PKC), THE PRIMARY DAG EFFECTOR.....	4
2.2.1 PKC family members and domain structure	4
2.2.2 Structure and function of PKC C1 domains	5
2.2.3 Regulation of PKC activity.....	7
2.2.4 PKC-mediated signal transduction.....	9
2.3 OTHER DAG EFFECTORS	11
2.3.1 Protein kinase D (PKD)	11
2.3.2 Diacylglycerol kinases (DGKs)	13
2.3.3 Myotonic dystrophy kinase-related Cdc42-binding kinases (MRCKs).....	14
2.3.4 Munc13 proteins.....	15
2.3.5 Chimaerins	17
2.3.6 Ras guanyl-releasing proteins (RasGRPs)	18
2.4 POTENTIAL THERAPEUTIC INDICATIONS FOR DAG EFFECTOR-TARGETED DRUGS	18
2.4.1 Cancer.....	19
2.4.2 Alzheimer's disease (AD).....	21
2.4.3 Other therapeutic indications.....	23
2.5 C1 DOMAIN LIGANDS.....	25
2.5.1 Phorbol esters and phorbol derivatives	25
2.5.2 Bryostatins and their synthetic analogues	26
2.5.2 Ingenol derivatives.....	27
2.5.3 DAG lactones	28
2.5.4 Indolactams and benzolactams	28
2.5.5 Other C1 domain ligands	29
3. AIMS OF THE STUDY	30
4. MATERIALS AND METHODS	31
4.1 DRUGS.....	31
4.2 PRODUCTION AND PURIFICATION OF RECOMBINANT PROTEINS	32
4.2.1 Production of PKC α , PKC δ and β 2-chimaerin in Sf9 insect cells (I, III).....	32
4.2.2 Preparation of Sf9 cell homogenates (I, III)	32
4.2.3 Production of the C1 domain of MRCK α in E. coli (III).....	32
4.2.4 Purification the C1 domain of MRCK α (III).....	32
4.3 PHORBOL ESTER DISPLACEMENT ASSAYS	33
4.3.1 Filtration method for [³ H]PDBu binding (I, III, IV)	33
4.3.2 Centrifugation method for [³ H]PDBu binding (I, III).....	33
4.4 CELL CULTURE (I-IV)	33
4.4.1 RNA interference (III)	34
4.5 CELL VIABILITY AND PROLIFERATION ASSAYS	34
4.5.1 LDH assay (II)	34
4.5.2 MTT assay (II, III).....	35
4.5.3 Thymidine incorporation assay (II)	35
4.5.4 Cell proliferation and morphology analysis with Cell-IQ [®] (II, III, IV)	35
4.6 WESTERN BLOTTING	36
4.6.1 Sample preparation (I-IV)	36

4.6.2 Protein separation and detection (I-IV)	36
4.7 IMMUNOCYTOCHEMISTRY AND FLUORESCENCE MICROSCOPY (III)	37
4.8 GENOME-WIDE GENE EXPRESSION ANALYSIS (III, IV)	38
4.9 STATISTICAL ANALYSIS (I-IV)	38
5. RESULTS	39
5.1 STRUCTURE-ACTIVITY RELATIONSHIP STUDIES ON ISOPHTHALATE DERIVATIVES (I, III)	39
5.1.1 Binding to the C1 domain of PKC (I).....	39
5.1.2 Binding affinity constants for PKC α and PKC δ (I).....	39
5.1.3 Binding to other DAG effectors (III)	40
5.1.4 Effects on ERK1/2 signalling in HeLa cells (I)	41
5.2 EFFECTS OF ISOPHTHALATE DERIVATIVES IN HELA CELLS (II, III)	42
5.2.1 Viability and proliferation (II).....	42
5.2.2 Morphology and cytoskeleton (II, III).....	43
5.2.3 Mechanistic studies on isophthalate-induced effects in HeLa cells (II, III).....	45
5.3 EFFECTS OF ISOPHTHALATE DERIVATIVES IN SH-SY5Y CELLS (IV)	46
5.3.1 Cell proliferation, viability and morphology (IV).....	47
5.3.2 Genome-wide gene expression and GSEA (IV).....	48
5.3.3 PKC and ERK1/2 signalling and GAP-43 expression (IV)	48
5.4 EFFECTS OF ISOPHTHALATE DERIVATIVES ON PKC PROTEIN LEVELS (UNPUBLISHED)	49
6. DISCUSSION.....	50
6.1 STRUCTURE-ACTIVITY RELATIONSHIPS OF ISOPHTHALATE DERIVATIVES.....	50
6.2 EFFECTS OF ISOPHTHALATE DERIVATIVES ON PKC-MEDIATED SIGNALLING	51
6.3 EFFECTS OF ISOPHTHALATE DERIVATIVES ON CELL VIABILITY AND PROLIFERATION	52
6.4 EFFECTS OF ISOPHTHALATE DERIVATIVES ON CELL MORPHOLOGY AND CYTOSKELETON.....	55
6.5 GENERAL DISCUSSION.....	58
7. SUMMARY AND CONCLUSIONS	61
8. ACKNOWLEDGEMENTS.....	62
9. REFERENCES	64

ABSTRACT

Diacylglycerol (DAG) is a ubiquitous lipid second messenger that transmits signals from cell membrane receptors to intracellular effector proteins containing a specialized DAG recognition motif, the C1 domain. The protein kinase C (PKC) family of serine/threonine kinases is the best-characterized member of DAG effectors, but there are also six other families of proteins with a DAG-responsive C1 domain: (1) the protein kinase D (PKD) family; (2) the myotonic dystrophy kinase-related Cdc42-binding kinases (MRCKs); (3) the DAG kinases (DGKs); (4) the Munc13 proteins; (5) the chimaerins; and (6) the Ras guanyl-releasing proteins (RasGRPs). DAG-mediated signalling regulates many cellular functions such as cell proliferation, survival, differentiation, apoptosis and motility – processes that are often deregulated in cancer. As key mediators of these processes, several of the DAG effectors are regarded as promising targets for cancer drug development. Furthermore, PKC contributes to neuronal plasticity and inhibits many pathophysiological processes related to Alzheimer's disease. Activation of PKC is therefore considered a potential future therapeutic strategy for the treatment of Alzheimer's disease. The C1 domain thus represents a well-recognized drug target. However, the existing C1 domain ligands are extremely complex in their chemical structure and from the drug development point of view new C1 domain ligands with a feasible synthesis route are needed.

The purpose of these studies was to characterize the structure-activity relationships (SAR) of a novel group of C1 domain ligands, derivatives of 5-(hydroxymethyl)isophthalic acid. These compounds have a simple chemical structure and they are easy to synthesize. Furthermore, these studies aimed to investigate the *in vitro* pharmacology of the isophthalate derivatives especially focusing on their effects on cell proliferation and morphology.

The SAR studies revealed the structural elements indispensable for binding to the C1 domain of PKC: the hydroxymethyl group, both of the ester groups and sufficiently hydrophobic ester substituents. Importantly, the SAR model also held true with β 2-chimaerin, another C1-domain containing DAG effector. The active isophthalates bound to PKC with low micromolar affinities, and a selected example of these, HMI-1a3, was also shown to bind to the C1 domains of PKD1 and MRCK α at similar concentrations.

Several isophthalates had an antiproliferative effect in HeLa human cervical carcinoma cells. HMI-1a3 exhibited the most potent cytotoxic and antiproliferative effect of the derivatives tested. The isophthalates with no affinity to the C1 domain (e.g. NI-15e, the inactive derivative of HMI-1a3) had no effect on HeLa cell viability or proliferation, suggesting a C1 domain-mediated effect. HMI-1a3 also induced a morphological change characterized by cell elongation. It was accompanied with a marked reorganization of actin cytoskeleton: loss of focal adhesions and actin stress fibres. The elongation-inducing effect of HMI-1a3 was inhibited by an MRCK inhibitor, and thus seems to be at least partially mediated by MRCK. However, the mechanism of its antiproliferative effect remains unclear and may be mediated by several of the DAG effectors.

In SH-SY5Y neuroblastoma cells, which are widely used as an *in vitro* model for neuronal differentiation, HMI-1b11 inhibited cell proliferation and supported neurite growth. HMI-1a3 induced SH-SY5Y cell differentiation as well, but unlike HMI-1b11 it also induced cell death. Again, derivatives with poor binding affinity to the C1 domain had no effect. The HMI-1b11-induced response was accompanied by PKC-dependent ERK1/2 phosphorylation and up-regulation of GAP-43, which is known to mediate neuronal differentiation and to contribute to neurite outgrowth.

In conclusion, these studies identify derivatives of 5-(hydroxymethyl)isophthalic acid as a promising novel group of C1 domain ligands. The antiproliferative and cytotoxic HMI-1a3 serves as a potential lead molecule for cancer-related drug discovery. HMI-1b11 on the other hand may be useful in drug development related to neurodegenerative diseases because of its non-toxic and differentiation-inducing properties in SH-SY5Y cells. More studies using cell-based and *in vivo* models are, however, needed to fully assess the potential of isophthalates in drug development.

ABBREVIATIONS

[³ H]PDBu	[20- ³ H]phorbol -12,13-dibutyrate
Aβ	Amyloid β protein
AD	Alzheimer's disease
AML	Acute myeloid leukaemia
ANOVA	Analysis of variance
aPKC	Atypical protein kinase C
APP	Amyloid precursor protein
ATP	Adenosine-5'-triphosphate
BAF	Boc-Asp(OMe) fluoromethyl ketone
CC (domain)	Coiled-coil (domain)
CNH (domain)	Citron homology (domain)
CNS	Central nervous system
cPKC	Classical/conventional protein kinase C
DB	Dulbecco's phosphate-buffered saline with 0.2% (w/v) BSA
DAG	Diacylglycerol
DAPI	4',6-Diamidino-2-phenylindole
DGK	Diacylglycerol kinase
DMEM	Dulbecco's modified Eagle's medium
DMSO	Dimethyl sulfoxide
DOG	1,2-Dioctanoyl- <i>sn</i> -glycerol
ECE	Endothelin-converting enzyme
ECL	Enhanced chemiluminescence
EDTA	Ethylenediaminetetraacetic acid
EGTA	Ethylene glycol tetraacetic acid
ERK	Extracellular signal-regulated kinase
ERM	Ezrin-radixin-moesin (a protein family)
FBS	Foetal bovine serum
GABA	γ-Aminobutyric acid
GAP-43	Growth-associated protein 43
GPCR	G protein-coupled receptor
GSEA	Gene set enrichment analysis
GSK3	Glycogen synthase kinase 3
GST	Glutathione S-transferase
GTP	Guanosine-5'-triphosphate
GTPase	Guanosine-5'-triphosphate hydrolase
HDAC	Histone deacetylase
HMI-1a3	Bis(3-trifluoromethylbenzyl) 5-(hydroxymethyl)isophthalate
HMI-1b10	Bis(1-ethylbutyl) 5-(hydroxymethyl)isophthalate
HMI-1b11	Bis(1-ethylpentyl) 5-(hydroxymethyl)isophthalate
HSD	Honestly significant difference
IC ₅₀	Half maximal inhibitory concentration
ICH	Immunocytochemistry
IgG	Immunoglobulin G
IKK	Inhibitor of NF-κB kinase
IP ₃	Inositol-1,4,5-trisphosphate
JNK	c-Jun N-terminal kinase
K _d	Equilibrium dissociation constant
K _i	Dissociation constant of the inhibitor
KIM	Kinase inhibitory motif
LDH	Lactate dehydrogenase
LIMK	LIM (domain) kinase
MAPK	Mitogen-activated protein kinase
MARCKS	Myristoylated alanine-rich C-kinase substrate
mDIA	Protein diaphanous homolog
MEF-2	Myocyte enhancer factor 2
MEK	MAPK/ERK kinase

MI-40	Bis(1-ethylpentyl) 5-methylisophthalate
MLC	Myosin light chain
MRCK	Myotonic dystrophy kinase-related Cdc42-binding kinase
mRNA	Messenger RNA
MTT	3-(4,5-Dimethylthiazol-2-yl)-2,5-diphenyltetrazolium bromide
MUN (domain)	Minimal region for Munc13 activity
nELAV	Neuronal embryonic lethal abnormal vision (protein)
NFD motif	Asparagine-phenylalanine-aspartate motif
NF- κ B	Nuclear factor kappa-B
NI-15e	Bis(3-trifluoromethylbenzyl) 5-nitroisophthalate
nPKC	Novel protein kinase C
p38	p38 MAPK (mitogen-activated protein kinases 11-14)
PA	Phosphatidic acid
PAK4	p21-activated kinase 4
PAP	Phosphatidic acid phosphohydrolase
PB1 (domain)	Phox and Bem 1 (domain)
PBD	p21-binding domain
PBS	Phosphate-buffered saline
PC	Phosphatidylcholine
PDBu	Phorbol-12,13-dibutyrate
PH (domain)	Pleckstrin homology (domain)
PIP ₂	Phosphatidylinositol-4,5-bisphosphate
PKB	Protein kinase B (aka Akt)
PKC	Protein kinase C
PKD	Protein kinase D
PLC	Phospholipase C
PLD	Phospholipase D
PMA	Phorbol-12-myristate-13-acetate
PS	Phosphatidylserine
PSS	Pseudosubstrate sequence
Rac-GAP	Rac GTPase-activating protein
RACK	Receptor for activated C kinase
RasGEF	Ras guanine nucleotide exchange factor
RasGRP	Ras guanyl-releasing protein
REM	Ras exchange motif
RIN1	Ras and Rab interactor 1
RNAi	RNA interference
ROCK	Rho-associated protein kinase
RT	Room temperature
RTK	Receptor tyrosine kinase
RVH (domain)	recoverin homology (domain)
sAPP α	Soluble amyloid precursor protein α
SAR	Structure-activity relationship
SDS	Sodium dodecyl sulphate
SDS-PAGE	SDS polyacrylamide gel electrophoresis
SEM	Standard error of mean
Sf9	<i>Spodoptera frugiperda</i> 9
SH2 (domain)	Src homology 2 (domain)
siRNA	Small interfering RNA
SNARE	Soluble N-ethylmaleimide sensitive fusion protein (NSF) attachment protein receptor
STAT	Signal transducer and activator of transcription
SSH	Protein phosphatase Slingshot homolog
TBS	Tris-buffered saline
TGN	Trans-Golgi network
Tris	Tris(hydroxymethyl)aminomethane
TTBS	0.1% Tween 20 in Tris-buffered saline
WAVE	Wiskott-Aldrich syndrome protein (WASP) family member

ORIGINAL PUBLICATIONS

This dissertation is based on the following original publications:

- I Boije af Gennäs Gustav*, Talman Virpi*, Aitio Olli*, Ekokoski Elina, Finel Moshe, Tuominen Raimo K, Yli-Kauhaluoma Jari (2009) Design, synthesis and biological activity of isophthalic acid derivatives targeted to the C1 domain of PKC. *J Med Chem* 52: 3969-81.
*equal contribution
- II Talman Virpi, Tuominen Raimo K, Boije af Gennäs Gustav, Yli-Kauhaluoma Jari, Ekokoski Elina (2011) C1 domain-targeted isophthalate derivatives induce cell elongation and cell cycle arrest in HeLa cells. *PLoS ONE* 6(5): e20053.
- III Talman Virpi, Gateva Gergana, Ahti Marja, Ekokoski Elina, Lappalainen Pekka, Tuominen Raimo K. HeLa cell elongation induced by the C1 domain-binding isophthalate HMI-1a3 is inhibited by the MRCK inhibitor chelerythrine. *Submitted*.
- IV Talman Virpi*, Amadio Marialaura*, Osera Cecilia, Sorvari Salla, Boije af Gennäs Gustav, Yli-Kauhaluoma Jari, Rossi Daniela, Govoni Stefano, Collina Simona, Ekokoski Elina, Tuominen Raimo K, Pascale Alessia (2013) The C1 domain-targeted isophthalate derivative HMI-1b11 promotes neurite outgrowth and GAP-43 expression through PKC α activation in SH-SY5Y cells. *Pharmacol Res* 73: 44-54.
*equal contribution

The publications are referred to in the text by their roman numerals. The supporting information of original publications I and IV is not included in this thesis. The material is available from the author or via the internet at <http://pubs.acs.org/doi/suppl/10.1021/jm900229p> (46 pages) for the original publication I and at <http://www.sciencedirect.com/science/article/pii/S1043661813000820> (3 pages) for the original publication IV. The original publications were reproduced with permission from the copyright holders.

1. INTRODUCTION

Protein kinases are enzymes that transfer phosphate groups from adenosine-5'-triphosphate (ATP) to their substrate proteins, generally resulting in a functional change (activation or inactivation) of the substrate. The human genome contains 518 protein kinase genes, which is 2% of all genes (Manning et al., 2002). Most eukaryotic protein kinases phosphorylate specifically serine and threonine residues in their substrates (serine/threonine kinases); some phosphorylate specifically tyrosine residues (tyrosine kinases); and a small number of kinases are able to phosphorylate all three of them (dual-specificity kinases). Protein kinases are important components of signalling cascades that regulate cell proliferation, survival, differentiation, migration and apoptosis – processes that are deregulated in for example cancer and neurodegenerative diseases.

In 1977, Yasutomi Nishizuka's group from the University of Kobe, Japan, published the first reports of a cyclic nucleotide-independent protein kinase and named it protein kinase M (M for magnesium-dependent activation) (Inoue et al., 1977; Takai et al., 1977). The enzyme was subsequently found to be activated by calcium and phospholipids and renamed protein kinase C (PKC), where C stands for calcium-dependent activation (Takai et al., 1979). Furthermore, the same group also identified diacylglycerol (DAG) as the second messenger regulating PKC activity (Kishimoto et al., 1980). Later on, it was found that PKC is not a single protein species, but actually a family of several isoforms that to some extent differ from each other both structurally and functionally.

PKC was initially shown to mediate thrombin-induced release of serotonin in human platelets (Kawahara et al., 1980). However, it was the discovery of PKC being the receptor for the tumour-promoting phorbol esters that implicated a role for PKC in controlling cell proliferation and cancer development (Castagna et al., 1982; Nishizuka, 1984). Since then, PKC has attracted enormous interest as a drug target first in cancer and later in many other diseases. Changes in PKC activity and increased or decreased expression levels of different PKC isoforms have been found in many types of cancer (Hofmann, 2004; Griner and Kazanietz, 2007). Depending on the cell type, the tissue of origin and the PKC isoform, PKCs can act as tumour promoters or tumour suppressors; thus both PKC inhibitors and activators may have potential in cancer therapy. Furthermore, vast evidence implies a role for PKC in the pathophysiology of numerous other diseases, such as Alzheimer's disease (AD), cardiac failure, autoimmune disorders and vascular complications of diabetes (Mochly-Rosen et al., 2012).

There are several possible binding sites for drugs within PKC. The conventional route of producing kinase inhibitors – by targeting the ATP binding site within the catalytic domain – has not been successful with PKC due to lack of specificity (Mochly-Rosen et al., 2012). Many PKC inhibitors have been studied in clinical trials, but none of them have yet reached the market. Problems with selectivity are not surprising, taking into account the vast number of protein kinases with relatively identical ATP-binding clefts. The regulatory region of PKC, and especially the C1 domain, may provide a possibility to develop compounds that are more selective. This approach also enables the development of PKC activators, since the C1 domain is the binding site for DAG and phorbol esters. Even though PKCs are not the only proteins containing a DAG- and phorbol ester-responsive C1 domain, the number of such proteins is considerably smaller than the number of protein kinases, and thus selectivity may be easier to achieve.

A number of C1 domain ligands have been described in the literature: some of them are derived directly from nature, and some are derivatives or analogues of naturally occurring compounds (Boije af Gennäs et al., 2011). As most of the C1 domain ligands from natural sources are highly complex in their chemical structure, their commercial production and chemical modification (e.g. for improving selectivity) is generally unfeasible. The aim of this work was to study structure-activity relationships of a novel group of C1 domain ligands, 5-(hydroxymethyl)isophthalates. The isophthalate derivatives are based on a simple C1 domain-binding template which enables easy synthesis and chemical modification. Furthermore, this work aimed at characterizing the pharmacological effects of the most promising compounds in HeLa human cervical cancer cells and in SH-SY5Y neuroblastoma cells, focusing especially on cell proliferation and morphology.

2. REVIEW OF THE LITERATURE

2.1 Diacylglycerol (DAG) signalling

Phospholipids are major components of cell membrane lipid bilayers. First clues of their role in signal transduction were brought forward in 1953, when ^{32}P from radiolabelled ATP was found to be incorporated into phospholipids after acetylcholine-mediated stimulation of pancreatic slices (Hokin and Hokin, 1953). Later work has shown that phospholipid hydrolysis is a common phenomenon following stimulation of cells by a variety of extracellular signals.

Diacylglycerol (DAG) is a simple lipid consisting of two fatty acids linked to a glycerol molecule through ester bonds. The combinations of fatty acid chains linked to the positions 1 and 2 of the glycerol backbone may vary, and thus DAG represents a family of heterogenic species (Carrasco and Merida, 2007). It is a constituent of biological membranes, intermediate in the synthesis of more complex lipids, and a source of free fatty acids. First and foremost, DAG plays a major role as a ubiquitous second messenger in signal transduction. It was initially found to activate PKC (Kishimoto et al., 1980; Nishizuka, 1992). Thereafter, it has been found to transmit signals from more than 100 cell surface receptors to its effector proteins inside the cell (Rhee, 2001).

Agonist-induced activation of various G protein-coupled receptors (GPCRs) and receptor tyrosine kinases (RTKs) leads to activation of phospholipase C (PLC), which hydrolyses phosphatidylinositol-4,5-bisphosphate (PIP_2) within the cell membrane (Rhee, 2001). As a result, DAG and inositol-1,4,5-trisphosphate (IP_3) are formed. DAG remains at the inner layer of the phospholipid membrane and IP_3 diffuses throughout the cytosol and acts to release calcium from the endoplasmic reticulum. Alternatively, DAG can also be produced indirectly from phosphatidylcholine (PC) via phospholipase D (PLD) and phosphatidic acid phosphohydrolase (PAP) (Martin, 1988): First PLD hydrolyses PC to yield choline and phosphatidic acid (PA), and PA is then further converted to DAG by PAP. DAG production through PLD and PAP is slower and longer-lasting than direct production via PLC, thus providing a DAG synthesis route with a different temporal pattern. At Golgi membranes, DAG can also be produced by sphingomyelin synthase, which transforms ceramide and PC into sphingomyelin and DAG (Villani et al., 2008). In lipid metabolism DAG is further converted to monoacylglycerols by DAG lipases or to triacylglycerols by diacylglycerol acyltransferases (Carrasco and Merida, 2007). It can also be transformed to PC or phosphatidylethanolamine, both of which can be further metabolized to phosphatidylserine (PS). However, the main route for terminating the DAG signalling after phospholipid hydrolysis is diacylglycerol kinase (DGK)-catalysed phosphorylation of DAG to yield PA (Topham and Epand, 2009).

Increased DAG concentration within cellular membranes recruits its target proteins to the membrane, where they bind DAG by a specialized recognition module, the C1 domain. C1 domains were first characterized in PKC (Nishizuka, 1988), but since then six additional classes of proteins have been reported to contain DAG-responsive C1 domains (see chapter 2.3). While the C1 domain is regarded as the major receptor for DAG, also other protein domains, such as the catalytic domains of DAG kinases and DAG lipases, can bind DAG. With numerous routes for synthesis and degradation and various effector proteins, precise control of DAG production and clearance is crucial for appropriate cellular function. DAG-mediated signal transduction requires rapid and transient

changes in DAG pools at specific cellular compartments. Together with other intracellular responses, the spatiotemporal control of DAG production determines the nature, intensity and duration of signals initiated. Localized DAG synthesis at specific cellular compartments, such as plasma membrane, Golgi or mitochondria, also serves as a means of regulating downstream signalling. Furthermore, DAG production via PLC- or PLD-mediated pathways differ not only in temporal aspect but also in DAG species generated, and this may affect downstream signalling (Carrasco and Merida, 2007). How DAG signalling is targeted to a specific DAG effector is, however, not known.

Phorbol esters, such as phorbol-12-myristate-13-acetate (PMA) and phorbol-12,13-dibutyrate (PDBu) are natural toxins that mimic the actions of DAG and induce translocation of PKC and other DAG effectors to the membrane via binding to the C1 domain (Goel et al., 2007). They have been widely used as research tools to decipher the physiological roles of PKC and other DAG effectors. However, since phorbol esters are more potent and stable than DAG, the responses evoked by them in the cellular environment differ greatly from those initiated by the physiological ligand DAG.

2.2 Protein kinase C (PKC), the primary DAG effector

2.2.1 PKC family members and domain structure

The family of PKC serine/threonine kinases consists of ten isoenzymes making up 2% of the human kinome, and is classified under the group of AGC kinases (named AGC after protein kinases A, G and C) (Manning et al., 2002). PKC isoforms are formed of a single polypeptide chain containing a conserved catalytic domain and a more variable regulatory region that are linked together with a so-called hinge region (Newton, 2001). They are divided into three classes based on their regulatory domain structure and activation requirements (Fig. 1). The classical/conventional PKCs (cPKCs) α , β and γ were the first individual isoforms discovered (Coussens et al., 1986). Due to alternative splicing, the gene encoding PKC β produces two protein transcripts, PKC β I and PKC β II that differ at their C terminus (Coussens et al., 1987). The calcium-independent subgroup of novel PKCs (nPKCs) comprises of isoforms δ , ϵ , η and θ (Ono et al., 1987; Osada et al., 1990; Osada et al., 1992); and the isoforms ζ and ι/λ (human/mouse homologues, respectively) belong to the subgroup of atypical PKCs (aPKCs) (Newton, 2001). The atypical PKC isoforms are more distant members of the PKC family and are not activated by DAG, like cPKCs and nPKCs. Therefore, they are not covered in this literature review.

The PKC catalytic domain resides in the C-terminal end of the polypeptide and shares substantial similarity with other serine/threonine as well as tyrosine kinases (Newton, 2001). It follows a classical bilobal kinase fold consisting of a smaller N-terminal lobe that is mainly composed of β sheets and contains the glycine-rich ATP binding site (C3 domain), and a larger predominantly α helical C-terminal lobe with binding sites for magnesium and substrates (C4 domain) (Xu et al., 2004; Grodsky et al., 2006). The C-terminal end of the catalytic domain, (V5 sequence), is more variable among PKC isoforms and participates e.g. in the regulation of the subcellular localization of the enzyme (Newton, 2001).

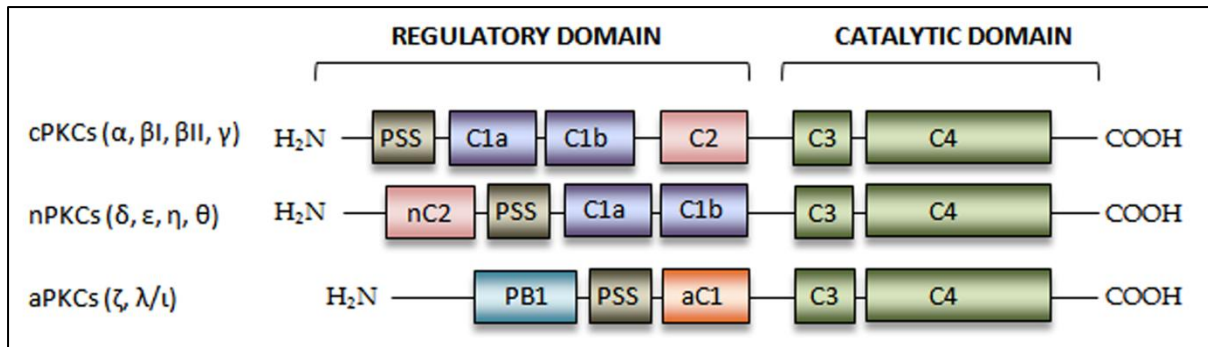

Figure 1. Schematic domain structures of protein kinase C (PKC) family members. The regulatory domains in the N-terminal part of classical and novel PKC isoforms (cPKCs and nPKCs, respectively) contain the C1a and C1b domains that are receptors for diacylglycerol (DAG), while the atypical C1 domain (aC1) of atypical PKCs (aPKCs) is unresponsive to DAG. The C2 domains bind anionic phospholipids and, in the case of cPKCs, Ca^{2+} . The C2 domain of nPKCs (nC2) is insensitive to Ca^{2+} . All PKC isoforms have a pseudosubstrate sequence (PSS) in the regulatory region and aPKCs also contain a Phox and Bem 1 (PB1) domain. The catalytic domain consists of two conserved subdomains: the C3 motif contains the ATP binding site, and the C4 motif binds substrates and magnesium. Reprinted with colours from IV with permission from Elsevier.

All PKC isoforms contain an autoinhibitory pseudosubstrate sequence (PSS) in their regulatory region (Newton, 2001). The sequence of the pseudosubstrate resembles that of substrate peptides, but the threonine or serine in the phosphoacceptor position is replaced by alanine. It regulates PKC enzymatic activity by binding to the substrate binding site and thus blocking the entry of substrates into the active cleft (House and Kemp, 1987). The regulatory regions of cPKCs and nPKCs also contain a tandem repeat of cysteine-rich C1-domains designated C1a and C1b (Hurley et al., 1997), which participate in the allosteric regulation and membrane targeting of PKC. Their structure and function are described in section 2.2.2.

The C2 domain found in the regulatory region of cPKCs and nPKCs, as well as in a large number of unrelated proteins, is a globular domain that is mainly composed of anti-parallel β strands (Sutton et al., 1995). It is a membrane-targeting module with affinity for anionic phospholipids and phosphatidylinositols (Rizo and Südhof, 1998). The C2 domains of cPKCs bind Ca^{2+} : crystal structures of PKC α and PKC β C2 domains revealed binding of two or three Ca^{2+} ions to conserved aspartic acid (Asp) residues and coordination of a PS directly to one of the Ca^{2+} ions (Sutton and Sprang, 1998; Verdaguer et al., 1999; Ochoa et al., 2002). The Ca^{2+} -insensitive nPKC isoforms have C2 domains that lack the Asp residues critical for Ca^{2+} binding and are thus insensitive to Ca^{2+} (Ochoa et al., 2001). They possess a different topology and their Ca^{2+} -independent binding to anionic lipids is mediated by loops 1 and 3 (Pappa et al., 1998; Ochoa et al., 2001). Besides serving as membrane-targeting modules, the PKC C2 domains are involved in PKC autoinhibition by intramolecular interactions with the C1 domain and in mediating protein-protein interactions (Kirwan et al., 2003; Benes et al., 2005).

2.2.2 Structure and function of PKC C1 domains

The PKC C1 domain was first identified as the conserved binding site for DAG and phorbol esters (Ono et al., 1989). It is a cysteine-rich structure of approximately 50 amino acids, with a characteristic $HX_{12}CX_2CX_{13-14}CX_2CX_4HX_2CX_7C$ motif, where H is histidine, C is cysteine, and X is any

amino acid (Ono et al., 1989; Steinberg, 2008). The sequence resembles that of the zinc finger motif in some DNA-binding proteins (Ono et al., 1989), and correct folding of the domain requires coordinated binding of two zinc ions (Hommel et al., 1994). However, the C1 domain adopts a globular fold distinct from the DNA-binding zinc finger motifs. The crystal structure of PKC δ C1b domain with bound phorbol ester revealed that the binding site for DAG and phorbol esters is a polar groove in an otherwise hydrophobic surface of the “top” part of the C1 domain (Zhang et al., 1995). Phorbol ester binding covers the polar surface of the binding groove and completes a continuous hydrophobic surface enabling the C1 domain to penetrate partially into the lipid bilayer. The positively-charged residues in the middle part of the domain may then further stabilize the membrane insertion by interacting with negatively-charged head groups of acidic phospholipids at the membrane.

All full-length cPKC and nPKC isoforms exhibit similar affinities for DAG (dissociation constant for [3 H]PDBu binding $K_i=0.2-0.4 \mu\text{M}$) and phorbol esters (equilibrium dissociation constant K_d for PDBu $<1 \text{ nM}$) (Kazanietz et al., 1993). Binding is fully dependent on phospholipids, particularly on PS. However, depending on the isoform, the individual C1a and C1b domains play either equivalent or non-equivalent roles in ligand binding and membrane targeting. The classical PKC γ and the novel PKC ϵ have C1a and C1b domains that bind both DAG and phorbol esters with high affinity and both C1 domains contribute to membrane binding of these isoforms (Irie et al., 1998; Ananthanarayanan et al., 2003; Stahelin et al., 2005). The individual C1 domains of other PKC isoforms, however, seem to play unequal roles. For example, the C1a domains of cPKC α and nPKC δ have a higher affinity for DAG, while the phorbol ester-induced activation is mediated by high affinity binding to the C1b domains (Slater et al., 1996; Ananthanarayanan et al., 2003; Stahelin et al., 2004). By contrast, the C1b domain plays a dominant role in DAG-induced membrane targeting of PKC θ (Melowic et al., 2007), which may be mediated by a differentially oriented tryptophan residue at the rim of the ligand-binding cleft (Rahman et al., 2013).

The C1 domains also play important roles in determining the subcellular destination of PKC translocation. The hydrophilicity/lipophilicity of the lipid activator can affect PKC distribution (Wang et al., 2000). Although the binding of PKC to PS and other anionic phospholipids is mediated by the C2 domain, the PS-specificity of cPKCs is mediated by their C1 domains (Bittova et al., 2001). Furthermore, additional lipid cofactors, such as ceramide and arachidonic acid can translocate PKCs to different cell membranes (Huwiler et al., 1998; Kashiwagi et al., 2002). At least for PKC δ and PKC ϵ this has been shown to be mediated via the C1b domain (Kashiwagi et al., 2002).

An emerging role for the C1 domains is in mediating protein-protein interactions. For example, several isoforms are targeted to Golgi via a conserved methionine in the C1b domain (Schultz et al., 2004). The binding partner for C1 domains in the Golgi compartment has been identified as Golgi/endoplasmic reticulum protein p23 (Tnp21) (Wang and Kazanietz, 2010). Furthermore, PKC β II binds the centrosomal protein pericentrin via its C1a domain and thereby regulates microtubule organization (Chen et al., 2004), and PKC ϵ interacts with the intermediate filament protein peripherin via its C1b domain (Sunesson et al., 2008). The C1 domain-mediated protein-protein interactions play a role in targeting PKC activity to a certain subcellular compartment, but they may also account for some of the non-catalytic functions of PKCs (see section 2.2.4). However, the extent and significance of protein-protein interactions in regulating PKC functions is not thoroughly understood.

2.2.3 Regulation of PKC activity

The activity of PKC is under strict regulation, and its phosphorylation state, conformation, and subcellular localization must be correct for its proper function. Newly synthesized PKC is catalytically incompetent and requires a series of priming phosphorylations to gain catalytic competence and appropriate intracellular localization (Newton, 2001; Steinberg, 2008). The three conserved phosphorylation sites lie within the catalytic domain: the activation loop (T497 in PKC α), the turn motif (T638 in PKC α) and the hydrophobic motif (T657 in PKC α). The mature (phosphorylated) PKC is maintained in an inactive conformation in cytosol and its activation is regulated allosterically by C1 and C2 domains. The allosteric activation mechanisms of classical and novel PKC subfamilies differ substantially from each other and are therefore presented separately.

The activity of cPKCs is predominantly regulated by intracellular levels of Ca²⁺ and DAG, and the additional lipid cofactors, such as PS, play a role in membrane targeting (Nishizuka, 1988; Nishizuka, 1992). A schematic model of cPKC activation is presented in Figure 2. Upon phospholipid hydrolysis, increased intracellular Ca²⁺ concentration first leads to binding of Ca²⁺ to the C2 domain, which increases the affinity of the C2 domain for anionic lipids and induces a rapid translocation of PKC from the cytosol to the cell membrane (Oancea and Meyer, 1998; Medkova and Cho, 1999; Bittova et al., 2001). The C2 domain-membrane interactions are mediated by PS and PIP₂ (Verdaguer et al., 1999; Corbalán-García et al., 2003a). At the membrane, cPKCs diffuse in a two-dimensional manner and the probability for encountering the rarer DAG molecules is thus increased (Nalefski and Newton, 2001). Increased DAG concentration at the membrane allows binding of DAG by the C1a domain thus inducing partial penetration of the C1a domain into the lipid bilayer and a conformational change that releases the PSS from the catalytic site (Leonard et al., 2011). The conformational change also uncovers the DAG binding site within the C1b domain, which in the inactive conformation is clamped by the C-terminal part of the catalytic domain: the so-called NFD (asparagine-phenylalanine-aspartate) motif and the amino acid residues immediately preceding it. Binding of another DAG molecule to the C1b domain releases the NFD motif thus enabling enzyme activation.

Notwithstanding the general requirement for Ca²⁺ in the activation of cPKCs, increased intracellular Ca²⁺ is dispensable for cPKC activation: a tight interaction of the C1 domain with phorbol esters or DAG can induce membrane penetration of the C1 domain and cPKC activation even in the absence of Ca²⁺ (Kazanietz et al., 1992). However, simultaneous Ca²⁺ signalling has been shown to accelerate DAG and phorbol ester binding and activation of PKC γ (Oancea and Meyer, 1998), and the interplay of calcium and phospholipids thus provides a way for spatial and temporal regulation of cPKCs.

Because of the Ca²⁺-insensitivity of their C2 domains, nPKCs are mainly regulated by DAG (Nishizuka, 1988; Newton, 2001). An increase in DAG level at cellular membranes induces nPKC translocation to the membrane, where the C1 domains bind DAG and penetrate partially into the membrane releasing the PSS from the catalytic site (Lehel et al., 1995). Whether a conformational change including the NFD motif is involved also in nPKC activation is not known. Depending on the nPKC isoform, their C2 domains play diverging roles in membrane binding. The C2 domain of PKC ϵ participates in membrane docking by binding to anionic phospholipids (Ochoa et al., 2001). In contrast to cPKCs, it shows however no selectivity for PS and actually binds PA-containing membranes with a slightly higher affinity than those containing PS (Corbalán-García et al., 2003b). The C2 domains of PKC δ and PKC θ are structurally different from those of PKC ϵ and PKC η (see

Corbalán-García and Gomez-Fernandez, 2010), and at least the PKC δ C2 domain does not participate in membrane recruitment (Giorgione et al., 2006). The lack of C2 domain-membrane interaction is compensated by increased affinity of the C1 domain for DAG-containing membranes (Dries et al., 2007).

In addition to the general activation by Ca²⁺ and lipid cofactors, alternative ways of PKC regulation exist. The nPKC isoforms δ , ϵ and θ can be cleaved in the hinge region by caspases 3 and 7 during apoptosis, leading to the release of constitutively active catalytic fragments (Emoto et al., 1995; Datta et al., 1997; Basu et al., 2002). Furthermore, oxidative modifications can also modulate PKC activity (Gopalakrishna and Jaken, 2000).

Physiological DAG-induced PKC activation is generally transient and is terminated when DAG is metabolized. However, in the case of prolonged PKC activation e.g. after phorbol ester exposure, the activity is terminated via down-regulation at the protein level (Newton, 2001). At least two pathways for agonist-induced PKC down-regulation have been identified: ubiquitination followed by degradation by the proteasome (Lee et al., 1996b) and degradation via a proteasome-independent mechanism (Leontieva and Black, 2004). Dephosphorylation plays a major role in directing PKC for down-regulation (Lee et al., 1996a). The serine/threonine phosphatase PHLPP (pleckstrin homology (PH) domain and leucine-rich repeat protein phosphatase) is known to dephosphorylate the hydrophobic motif of cPKCs and nPKCs, thus directing them to degradation by the proteasome-dependent pathway (Gao et al., 2008).

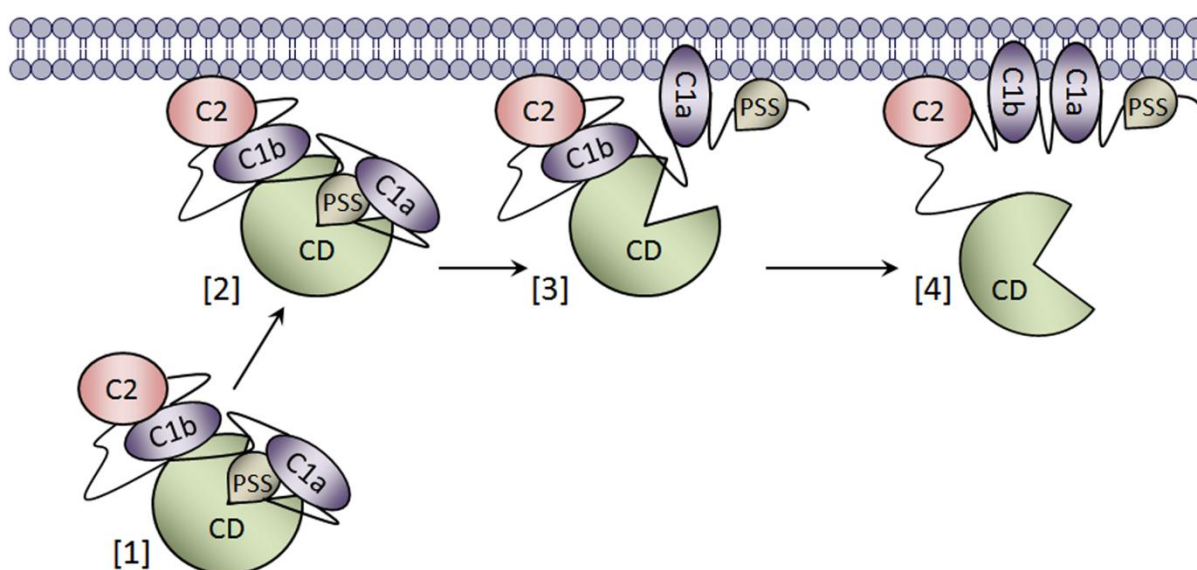

Figure 2. Schematic model for cPKC activation. Inactive PKC resides in cytosol with the pseudosubstrate sequence (PSS) and C1a domains masking the catalytic site within the catalytic domain (CD) [1]. Increased intracellular calcium concentration induces translocation of PKC to the membrane, where the C2 domain mediates binding to PS and PIP₂ [2]. Binding of DAG to the C1a domain induces a conformational change releasing the C1a domain and subsequently removing PSS from the catalytic cleft [3]. Binding of a second DAG molecule to the C1b domain results in unclamping of the C1b-kinase assembly thus activating the enzyme [4].

2.2.4 PKC-mediated signal transduction

Classical and novel PKCs are involved in an overwhelming variety of biological processes in eukaryotic organisms. Most importantly, they participate in signalling pathways controlling cell proliferation, survival, transformation, differentiation, inflammation and apoptosis (Fig. 3). Signalling routes that are controlled by PKC-mediated phosphorylation include, for instance, mitogen-activated protein kinase (MAPK) and stress-activated protein kinase (SAPK) cascades, nuclear factor κ B (NF- κ B) signalling, glycogen synthase kinase 3 (GSK3) signalling, protein kinase B (PKB) signalling, as well as signal transducer and activator of transcription (STAT)-regulated gene expression (Yang and Kazanietz, 2003; Mackay and Twelves, 2007). Although PKC isoforms are activated by the same second messengers and they have overlapping substrate specificities, PKC-mediated signal transduction is often specific for the isoform, for the cell type and for the stimulus. Different PKC isoforms can even have opposing effects on the same process (Chen et al., 2001; Tourkina et al., 2005). The reasons and mechanisms of such diversity are not thoroughly understood, but the unique compartmentalisation of PKC isoforms is thought to play an important role in mediating the isoform-specific effects (Yang and Kazanietz, 2003). Protein-protein interactions with a group of proteins called RACKs (receptors for activated C kinases) and other anchoring proteins participate in targeting specific PKC isoforms in close proximity to their substrates and thus control isoform-specific functions of PKCs (Mochly-Rosen, 1995). As an example, activation of c-Jun N-terminal kinase 1 (JNK1) signalling by PKC requires the presence of RACK1 (López-Bergami et al., 2005).

The Raf – MEK1/2 - ERK1/2 pathway is a good example of a signalling cascade, which can be activated by most PKC isoforms (Schönwasser et al., 1998; Mackay and Twelves, 2007). It controls cell cycle progression and cell differentiation and is implicated in induction of abnormal cell proliferation and oncogenic transformation (Roskoski, 2012). However, the outcome of PKC-induced ERK1/2 activation depends not only on the PKC isoforms, but also on the cell type and on the duration of activation. For example, PKC α activation leads to activation of ERK1/2, p38 MAPK and JNK, and subsequent cell differentiation and inhibition of proliferation in rhabdomyosarcoma cells (Mauro et al., 2002). However, in NIH3T3 mouse fibroblast cells PMA-induced PKC α activation initiates the ERK1/2 cascade and induces cell proliferation (Kolch et al., 1993). Furthermore, in cultured primary pituitary cells, a short (15 min) PMA exposure leads to PKC ϵ -mediated ERK1/2 activation and cell proliferation, while a longer (3 h) PMA treatment activates PKC α and attenuates the PMA-induced ERK1/2 activation and cell proliferation (Petiti et al., 2008). Moreover, the Raf-MEK-ERK1/2 cascade can be activated by PKCs in a Ras-dependent or independent manner. PKC δ activation by PMA leads to Ras-independent but Raf-dependent ERK1/2 activation in COS and NIH3T3 cells (Ueda et al., 1996), while estradiol induces PKC δ - and Ras-dependent ERK1/2 activation in MCF-7 breast cancer cells (Keshamouni et al., 2002).

An emerging role for PKC-mediated signalling lies in their non-catalytic functions, which are predominantly attributed to protein-protein interactions mediated by the regulatory domains. As an illustration, PKC ϵ induces neurite outgrowth in neuroblastoma cells via its C1b domain independently of catalytic activity (Zeidman et al., 1999a; Ling et al., 2007). Moreover, PKC α protein but not kinase activity is pivotal for glioma cell survival and proliferation (Cameron et al., 2008). The effect is mediated by the fully phosphorylated, folded form of PKC α , and it can be blocked with a C1 domain-targeted PKC inhibitor calphostin C, but not with an ATP-competitive inhibitor. However, the physiological relevance of these non-catalytic functions still remains to be clarified.

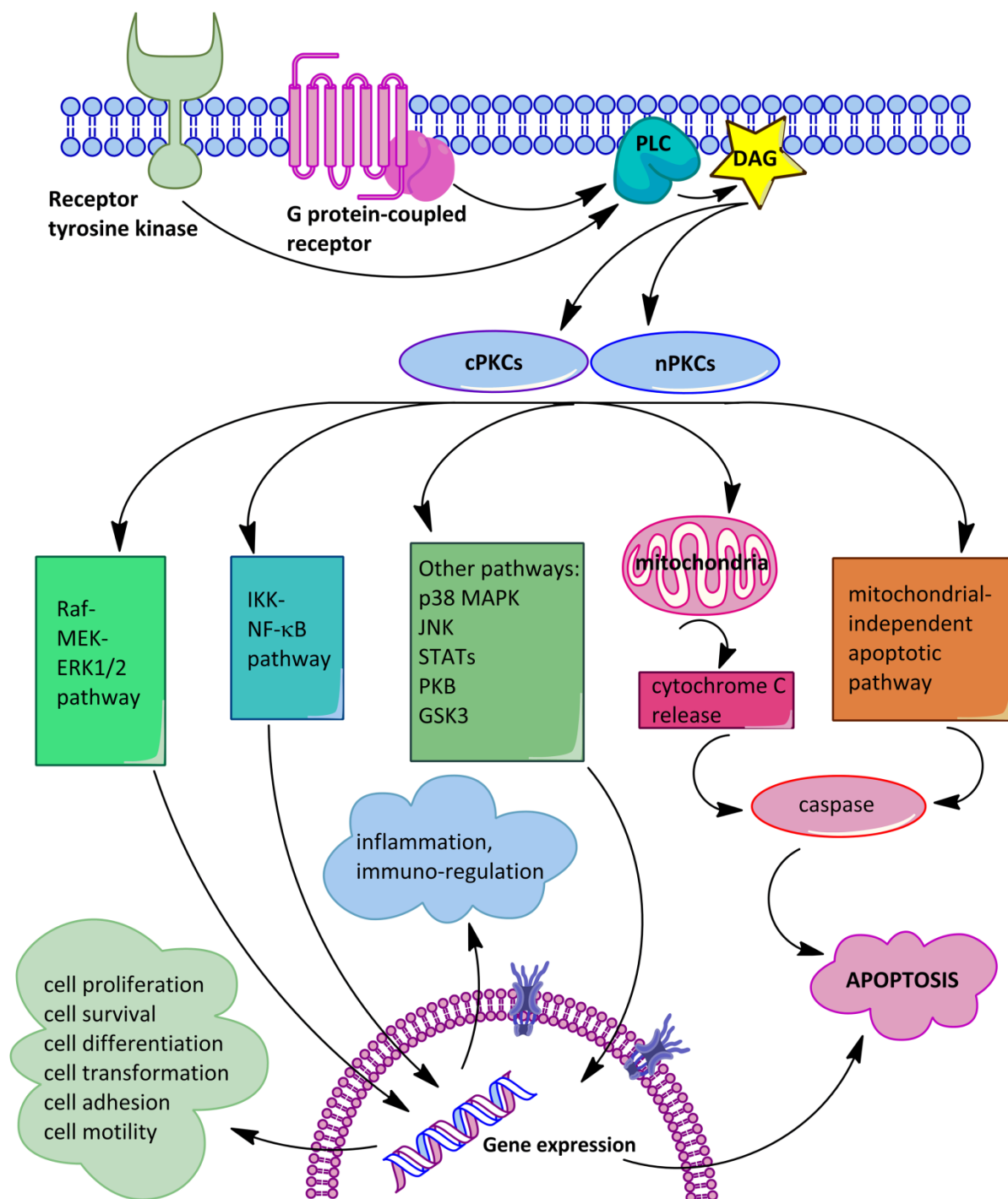

Figure 3. Signalling pathways regulated by DAG-responsive PKC isoforms. Transient diacylglycerol (DAG) generation after activation of receptor tyrosine kinases or G protein-coupled receptors activates classical and novel PKC isoforms. PKC activation modulates numerous signalling pathways that control for example cell survival, cell proliferation and apoptosis. ERK, extracellular signal-regulated protein kinase; GSK3, glycogen synthase kinase 3; IKK, inhibitor of κ B kinase; JNK, c-JUN N-terminal kinase; MAPK, mitogen-activated protein kinase; MEK, MAPK kinase; NF- κ B, nuclear factor κ B; PKB, protein kinase B; PLC, phospholipase C; STAT, signal transducer and activator of transcription.

A vast number of knock-out animal studies have been carried out to resolve the physiological importance of each PKC isoform. However, it seems that in many cases other PKC isoforms are able to substitute for the lacking one: despite the central role for PKC in signal transduction, all PKC

knock-outs are viable and exhibit only mild phenotypic changes (reviewed in Roffey et al., 2009). Therefore, only broad and non-specific assumptions of isoform-specific physiological roles can be made based on studies with genetically modified animals. Studies with PKC α -deficient mice suggest that PKC α plays an important role in insulin signalling through the phosphoinositide 3-kinase (PI3K) cascade (Leitges et al., 2002) and in tumour formation in the two-stage skin carcinogenesis model (Hara et al., 2005). PKC γ is prominently expressed in the CNS and plays a role in learning and memory: PKC γ -deficient mice have altered long-term potentiation of synaptic transmission in hippocampus and exhibit deficits in spatial and contextual learning (Abeliovich et al., 1993). Also PKC ϵ plays a role in the CNS: mice lacking PKC ϵ exhibit altered GABA $_A$ receptor signalling and attenuated hyperalgesia (Hodge et al., 1999; Khasar et al., 1999). Deficiency of PKC η has been reported to impair wound healing and enhance tumour formation in the two-stage skin carcinogenesis model (Chida et al., 2003), whereas PKC isoforms β , δ and θ seem to be important for correct operation of the immune system. PKC β and PKC δ play indispensable but opposing roles in B cell-mediated immunity: mice deficient in PKC β I and PKC β II develop B cell immunodeficiency, while knocking out PKC δ induces B cell proliferation and autoimmunity (Leitges et al., 1996; Miyamoto et al., 2002). As for PKC θ , mice deficient in this isoform exhibit impaired T cell receptor signalling (Sun et al., 2000).

2.3 Other DAG effectors

In addition to PKC, six other classes of proteins contain DAG- and phorbol ester-responsive C1 domains. Their schematic domain structures are presented in Figure 4. Many other proteins have atypical C1 domains that do not respond to DAG or phorbol esters. They are however not included in this literature review. Furthermore, DAG effectors that do not contain a C1 domain, such as transient receptor potential (TRP) channels, are not covered.

2.3.1 Protein kinase D (PKD)

The protein kinase D (PKD) family of serine/threonine kinases consists of three members: PKD1 (PKC μ), PKD2 and PKD3 (PKC ν) (Wang, 2006; Fu and Rubin, 2011). PKC μ and PKC ν were initially considered as members of the PKC family, but now PKD isoforms are classified as a subgroup of calcium/calmodulin-dependent protein kinase (CAMK) family based on sequence similarities of the catalytic domains (Manning et al., 2002). Similarly to PKC, PKD isoforms consist of an N-terminal regulatory region and a C-terminal catalytic domain (Fig. 4). The autoinhibitory regulatory domains include a tandem repeat of C1 domains (C1a and C1b) and a PH domain. Deletion of both C1 domains, the PH domain or the whole regulatory region leads to fully activated PKD1 (Iglesias and Rozengurt, 1998; Iglesias and Rozengurt, 1999; Vertommen et al., 2000). The individual C1 domains exhibit different ligand-binding affinities towards phorbol esters and DAG (Iglesias et al., 1998). The C1b domains of all PKD isoforms bind [3 H]PDBu with high affinity ($K_d < 1$ nM), while their affinities for the synthetic DAG analogue 1,2-dioleoyl-sn-glycerol (DOG) are substantially lower ($K_i = 154$ -168 nM) (Chen et al., 2008a). The C1a domains of PKD1 and PKD2 have very weak affinities for PDBu or DOG, while the PKD3 C1a domain exhibits high affinity for both PDBu ($K_d = 1.6$ nM) and DOG ($K_i = 44$ nM). The lipid requirements for ligand binding to the PKD C1 domains do not differ significantly from

those of PKCs despite different additional membrane-targeting domains (PH domain in PKD vs. C2 domain in PKC) (Wang et al., 2003).

The activation mechanisms are best known for PKD1, but based on the similar molecular architecture PKD2 and PKD3 are likely to share common regulation with PKD1. Binding of DAG to the C1 domain results in translocation of PKD to the membrane, but generally the translocation *per se* is not sufficient for PKD activation (Wang, 2006; Fu and Rubin, 2011). PKD1 can be activated by at least two mechanisms: (I) by phosphorylation of two conserved serines (S738 and S742 in PKD1) in the activation loop (Rozenfurt et al., 2005; Steinberg, 2012), and (II) by caspase-mediated cleavage resulting in the release of a constitutively active kinase domain (Endo et al., 2000).

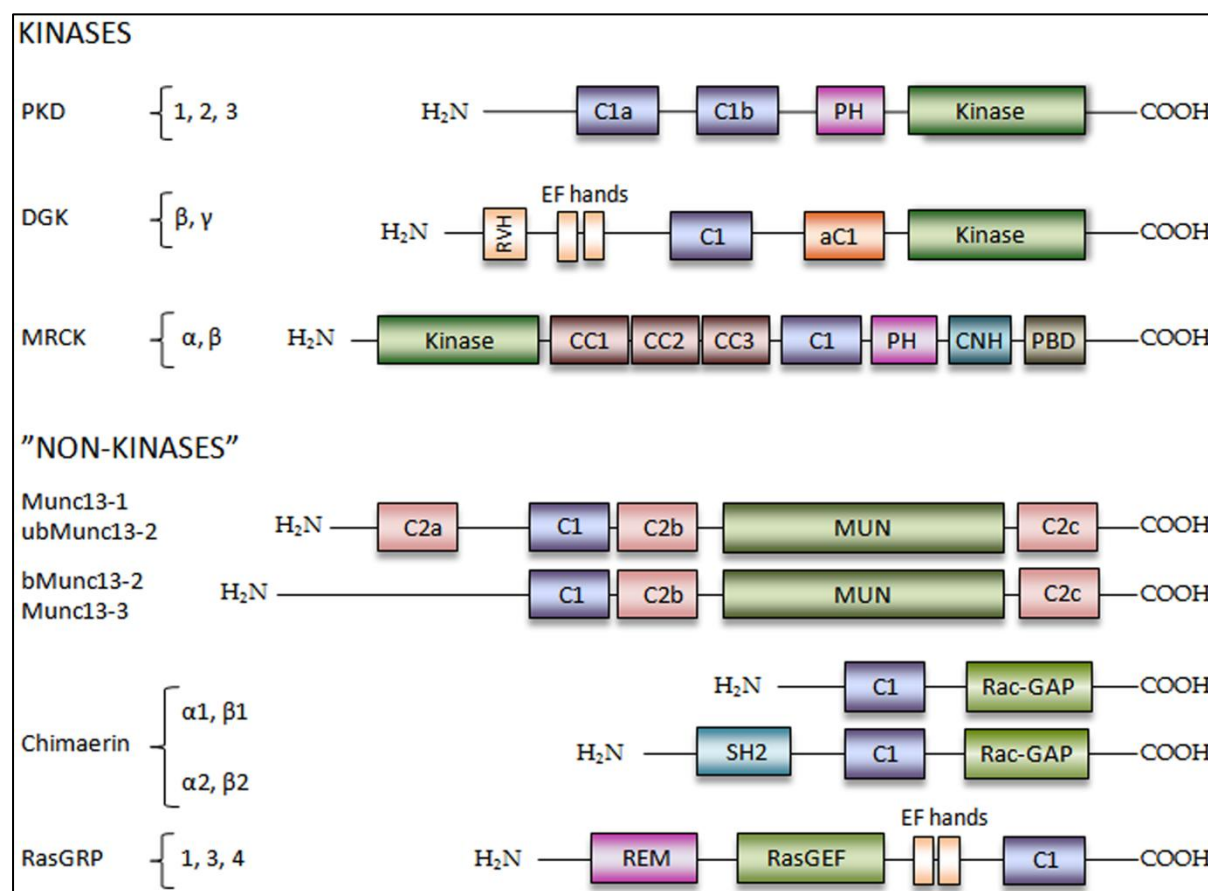

Figure 4. Schematic domain structures of “non-PKC” DAG effectors. All protein kinase D (PKD) isoforms (1-3) contain two diacylglycerol (DAG)-responsive C1 domains, whereas only diacylglycerol kinase (DGK) isoforms β and γ have C1 domains that bind DAG. The myotonic dystrophy kinase-related Cdc42-binding kinase (MRCK) isoforms α and β have been shown to bind DAG. All Munc13 isoforms (1-3) are physiological effectors of DAG. Both chimaerin genes, α - and β -chimaerin, produce two splice variants, all of which contain a DAG-responsive C1 domain. The Ras guanyl-releasing protein (RasGRP) isoforms 1, 3 and 4 are DAG-responsive, while RasGRP2 is not. aC1, atypical C1 domain; CC, coiled-coil domain; CNH, citron homology domain; C2, calcium-responsive C2 domain; MUN, MUN domain; PBD, p21-binding domain; PH, pleckstrin homology domain; Rac-GAP, Rac GTPase-activating protein (domain); RasGEF, Ras guanine nucleotide exchange factor (domain); REM, Ras exchange motif; RVH, recoverin homology domain; SH2, Src homology 2 domain.

Activation of PKD by phosphorylation is predominantly mediated by nPKCs, (Rozenfurt et al., 2005), but also PKC α can phosphorylate and activate PKD (Wong and Jin, 2005). DAG production at the plasma membrane thus activates PKD by activating its upstream kinase (PKC) and by inducing its colocalization with PKC, thus enabling phosphorylation (Matthews et al., 2000; Waldron and Rozenfurt, 2003). Several other phosphorylation sites and upstream kinases also regulate PKD1 activity and signalling in cells (see Steinberg, 2012). Selective activation of PKD isoforms may be mediated by colocalization of PKDs and receptor-PLC signalling modules in distinct membrane microdomains, as suggested by the Steinberg group (Guo et al., 2011). They showed that even though norepinephrine, endothelin 1 and thrombin all activate PLC β , norepinephrine selectively stimulates PKD1; thrombin selectively stimulates PKD2; and endothelin 1 stimulates both PKD1 and PKD2. However, the significance of this kind of selective regulation is unclear - especially since pathway-specific substrates are yet to be identified.

PKD isoforms promote cell survival and cell proliferation e.g. by phosphorylating heat shock protein 27 (Hsp27) and by inducing ERK1/2 phosphorylation (Wang, 2006; Guha et al., 2010). They control cytoskeleton reorganization and inhibit directed cell movement by phosphorylating and inactivating protein phosphatase SSH1L, which leads to accumulation of phosphorylated and inactive cofilin and thus inhibition of actin depolymerization (Eiseler et al., 2009). They also phosphorylate cortactin, which leads to inhibition of actin polymerization at the leading edge (Eiseler et al., 2010). PKDs can also suppress cell motility by phosphorylating the Ras and Rab interactor 1 (RIN1), E-cadherin and the transcription factor SNAI1, or by down-regulating matrix metalloproteinase (MMP) expression (Fu and Rubin, 2011; Olayioye et al., 2013). DAG-mediated recruitment of PKD to trans-Golgi network (TGN) regulates fission of protein and lipid transport vesicles that carry cargo from TGN to the cell surface (Liljedahl et al., 2001; Baron and Malhotra, 2002). PKD isoforms also participate in the control of gene expression by phosphorylating class II histone deacetylases (HDACs) 5 and 7 thereby attenuating HDAC-mediated repression of gene expression (see Fu and Rubin, 2011).

The physiological roles of individual PKD isoforms are still mostly unknown, but studies in genetically modified mice have shown that PKD1 is indispensable for embryonic development, since deficiency of catalytically active PKD1 causes embryonic lethality (Fielitz et al., 2008). Furthermore, cardiac-specific deletion of *Pkd1* revealed that PKD1 plays a key role in cardiac remodelling induced by stress stimuli (Fielitz et al., 2008). Mice deficient in PKD2 develop normally, but their T cell-dependent immunoglobulin G (IgG), immunoglobulin M and cytokine production is inhibited, implying that PKD2 plays a unique role in the regulation of mature peripheral lymphocytes (Matthews et al., 2010). No studies with PKD3 knock-out animals have been reported, but PKD3 has been suggested to play a role in pathological cardiac remodelling (Li et al., 2011) and in invasiveness of prostate cancer (Chen et al., 2008b).

2.3.2 Diacylglycerol kinases (DGKs)

DGKs are a family of lipid kinases that modulate intracellular levels of DAG and PA by phosphorylating DAG to yield PA (Shulga et al., 2011). The ten isoforms are divided into five subtypes based on their domain structure. In addition to the DAG-binding catalytic domain, all isoforms contain two or three C1 domains in their N-terminal regulatory region. However, only the C1a domains of DGK β and DGK γ respond to DAG and phorbol esters (Shindo et al., 2003), and therefore only these isoforms are covered in this literature review.

DGKs β and γ are classified into type I DGKs, and their schematic domain structure is presented in Figure 4 (Shulga et al., 2011). Interactions between the regulatory domains and the catalytic domain keep DGKs in an inactive state when no cofactors are present (Takahashi et al., 2012). Binding of Ca^{2+} to the EF hand motifs induces a conformational change that allows membrane binding and activation of the enzyme. The DGK C1 domains serve as membrane-targeting and protein-protein interaction modules. The affinities of PDBu and other C1 domain ligands for the individual DGK β and DGK γ C1a domains as well as for the whole DGK γ protein are in the same range as those observed for PKC (Shindo et al., 2003). DGK activity is also regulated by phosphorylation: for example, DGK γ can be activated via direct phosphorylation by PKC γ (Yamaguchi et al., 2006). DGK β has been reported to localize in cell periphery and to associate with actin cytoskeleton (Caricasole et al., 2002; Kobayashi et al., 2007), while DGK γ has been detected in the Golgi and nucleus (Matsubara et al., 2006; Kobayashi et al., 2007), suggesting isoform-specific physiological functions. Both isoforms, however, translocate to plasma membrane upon phorbol ester treatment (Shirai et al., 2000; Caricasole et al., 2002).

All DGK isoforms interfere with DAG signalling by ending the effects of elevated DAG levels, and thus their activity terminates DAG-initiated signalling mediated by other DAG effectors. Additionally, their influence extends to signalling cascades and proteins whose activity is regulated by PA (see Shulga et al., 2011). Although the cellular and physiological functions of DGKs have not been well characterized, several isoforms have been implicated in controlling cell proliferation and morphology and immune cell signalling (Sakane et al., 2007; Shulga et al., 2011). DGK β is prominently expressed in neurons and plays an important role in dendritic outgrowth and neurite spine formation, thereby contributing to cognitive processes and behaviour (Hozumi et al., 2009; Kakefuda et al., 2010; Shirai et al., 2010). DGK γ , which is also predominantly expressed in the CNS, has been implicated in cytoskeletal reorganization. It binds to and activates β 2-chimaerin (see section 2.3.5) thus inhibiting the formation of lamellipodia (Tsushima et al., 2004; Yasuda et al., 2007). It has also been suggested to play a role in the induction of filopodia-like protrusions independent of its catalytic activity (Tanino et al., 2012). Outside the CNS, DGK γ has been linked to macrophage differentiation (Yamada et al., 2003).

2.3.3 Myotonic dystrophy kinase-related Cdc42-binding kinases (MRCKs)

Myotonic dystrophy kinase-related Cdc42-binding kinases (MRCKs) are serine/threonine kinases that were first identified and characterized in 1998 (Leung et al., 1998). Originally two isoforms (MRCK α and MRCK β) were identified, and MRCK γ was described in 2004 (Ng et al., 2004). MRCKs are structurally related to dystrophin myotonic protein kinases and RhoA-binding kinases (Leung et al., 1998), and their domain organization differs substantially from that of other DAG-responsive protein kinases (Fig. 4) (Leung et al., 1998; Tan et al., 2001b). The catalytic domain lies in the N-terminal end and is followed by numerous regulatory domains. The coiled-coil (CC) domains, and especially a motif termed KIM (kinase inhibitory motif) within the CC domains 2-3, have an autoinhibitory role on MRCK kinase activity, and they are suggested to keep the dimeric kinase in an inactive closed conformation (Tan et al., 2001b). The CC domains are followed by a single C1 domain (see below) and a PH domain, which participates in controlling the localization of the enzyme by interacting with lipids and cytoskeleton. The p21-binding domain (PBD) is responsible for binding to the small GTPase Cdc42. This interaction is not essential for kinase activity, and thus probably serves to target MRCK to its activators and/or substrates (Leung et al., 1998). The crystal structure of MRCK β revealed that

in the active conformation the MRCK dimer is held together by interactions between four N-terminal helices and the C-termini of the kinase domains (Heikkilä et al., 2011).

The phorbol ester binding affinities of the isolated C1 domains of MRCK α and MRCK β are weaker (K_d values for PDBu 10 and 17 nM, respectively) as compared with those of C1b domains of PKC α or PKC δ (K_d values for PDBu 3.4 and 0.18 nM, respectively) (Choi et al., 2008). Furthermore, ligand selectivity of MRCK C1 domains resembles more that of PKC α C1b domain than that of PKC δ C1b, and the binding is fully dependent on PS. No information on the DAG/phorbol ester binding properties of MRCK γ C1 domain is available. Exposure of cells to PMA increased the kinase activity of immunoprecipitated MRCK α , and therefore it was proposed that ligand binding to the C1 domain induces a conformational change that disrupts the interaction between KIM and the catalytic domain and allows activation of the kinase (Tan et al., 2001b). However, no evidence of DAG-mediated activation of MRCKs in cellular context has been published. Due to the lower affinity of MRCK C1 domains for DAG it has been suggested that additional elements within the MRCK structure may be required to render the enzyme DAG-responsive (Choi et al., 2008). Alternatively, other physiological mechanisms may be more important in regulating MRCK activity. Indeed, direct interaction between KIM and leucine repeat adaptor protein 35a was shown to abrogate KIM-mediated MRCK autoinhibition and activate MRCK (Tan et al., 2008). Furthermore, alternative splicing of MRCK α may affect its activity and Cdc42 binding (Tan et al., 2003).

Although not as extensively studied as many other DAG effectors, the physiological role of MRCKs in regulating cytoskeletal proteins is quite well established. Upon identification, MRCKs were already described as effectors of the small GTPase Cdc42 in promoting cytoskeletal reorganization by phosphorylating myosin light chain (MLC) 2 (Leung et al., 1998). Furthermore, MRCKs have been shown to phosphorylate a number of other cytoskeleton-associated substrates, such as myosin 18 (Tan et al., 2008), myosin binding subunit of MLC phosphatase (Tan et al., 2001a), moesin (Nakamura et al., 2000) and LIM domain kinase (LIMK) (Sumi et al., 2001), which in turn phosphorylates and inactivates cofilin, an actin-depolymerizing protein. By controlling the actomyosin cytoskeleton reorganization, MRCKs have been shown to play a role in neurite outgrowth in PC12 cells (Chen et al., 1999) and in filopodia formation in NIH3T3 fibroblasts (Nakamura et al., 2000). They also control cell migration by regulating cell contractility (Groeger and Nobes, 2007) and by modulating lamellar actomyosin retrograde flow (Gomes et al., 2005). Furthermore, tumour cell invasion with rounded morphology is regulated by cooperated Cdc42/MRCK and Rho/Rho-associated protein kinase (ROCK) signalling, while invasion with elongated cell morphology depends on Cdc42/MRCK signalling (Wilkinson et al., 2005). Isoform-specific functions for MRCKs have not been reported; on the contrary, high functional redundancy seems to exist at least among isoforms α and β (Wilkinson et al., 2005; Lefort et al., 2007).

2.3.4 Munc13 proteins

Munc13s are a family of four mammalian homologues of *Caenorhabditis elegans* Unc-13 scaffolding protein that regulate synaptic vesicle exocytosis (Brose et al., 2000; Brose et al., 2004). The Munc13 isoforms 1–3 consist of two or three C2 domains depending on the isoform, a single C1 domain and a large MUN domain (Fig. 4) (Basu et al., 2005). Munc13-4 is truncated from the N-terminus so that it lacks the C1 domain and is therefore insensitive to DAG and phorbol esters (Koch et al., 2000).

The Munc13 C2 domains play a role in phospholipid recognition in a calcium-independent or calcium-dependent manner, depending on the C2 domain: only the C2b domains are sensitive to Ca^{2+} (Brose et al., 1995; Shin et al., 2010). Immediately N-terminal of the C1 domain lies a short sequence that serves as a calmodulin binding site and participates in the Ca^{2+} -dependent regulation of Munc13 function (Junge et al., 2004). The large MUN domain between the central and the C-terminal C2 domains is the minimal region for Munc13 activity and it exerts its effects via protein-protein interactions (Basu et al., 2005; Li et al., 2011). However, other domains also contribute, since expression of the isolated MUN domain results in only 50% rescue of Munc13 functions in neurons from Munc13-1 and Munc13-2 double knock-out mice (Basu et al., 2005).

The C1 domains of Unc-13 and Munc13-1 bind [^3H]PDBu in a phospholipid-dependent manner with low nanomolar affinity (Kazanietz et al., 1995; Betz et al., 1998). They also bind diacylglycerol and other C1 domain ligands with affinities close to that of PKC δ C1b domain, and Munc13 isoforms translocate to plasma membrane upon PMA treatment. The nuclear magnetic resonance (NMR) structure of Munc13-1 C1 domain showed an intramolecular occlusion of the DAG binding site caused by a tryptophan side chain, which was hypothesized to lead to lower affinities for the C1 domain ligands in cellular context (Shen et al., 2005). Such an effect has however not been reported in experimental conditions, and the relevance of the occlusion remains unclear.

Differential expression patterns of Munc13 isoforms implies that they may regulate cellular functions in a cell-type-specific manner. Munc13-1 is expressed in brain and in pancreatic islet cells; Munc13-2 is expressed as two splice variants (see Fig. 4): brain-specific bMunc13-2 and ubiquitous ubMunc13-2; while Munc13-3 is exclusively expressed in brain (Brose et al., 2000; Sheu et al., 2003). The physiological role of unc-13 and Munc13s is tightly bound to regulation of exocytosis, and their effects have mainly been studied in the CNS. In neurons, Munc13s participate in the regulation of calcium-triggered exocytotic fusion of synaptic vesicles by controlling the essential and rate-limiting step of exocytosis called priming (see Brose et al., 2000). It has been shown that Munc13-1 is indispensable for fusion competence of glutamatergic synaptic vesicles (Augustin et al., 1999), and that it regulates glutamatergic transmission together with Munc13-2 (Varoqueaux et al., 2002).

Genetically modified mice with deficiency in Munc13-1 or both Munc13-1 and Munc13-2, or mice that express a DAG-unresponsive Munc13-1 variant instead of the wild-type protein, die 2–3 hours after birth, even though their brains and synapses have developed normally (Augustin et al., 1999; Rhee et al., 2002; Varoqueaux et al., 2002), showing that Munc13s and their DAG-dependent regulation is essential for normal function of synapses in the CNS. Munc13s control synaptic vesicle priming by binding to syntaxin and promoting its open conformation, which then allows the formation of the SNARE (soluble NSF attachment protein receptor) complex and exocytosis (Ma et al., 2011). The Munc13-regulated pathway cooperates with DAG-mediated PKC signalling, and both pathways contribute to initiation of presynaptic potentiation (Wierda et al., 2007; Lou et al., 2008). Furthermore, by regulating vesicle fusion Munc13s also regulate neurite outgrowth prior to synaptogenesis (Broeke et al., 2010). Outside CNS, Munc13-1 has been shown to regulate insulin secretion in pancreatic beta cells (Sheu et al., 2003; Kang et al., 2006) and Munc13-2 has been reported to play a role in apoptosis (Song et al., 1999).

2.3.5 Chimaerins

The four chimaerin isoforms are Rac GTPase-activating proteins (Rac-GAPs) that are generated by alternative splicing of two genes (Yang and Kazanietz, 2007). The shorter splice variants, α 1- and β 1-chimaerins, possess a single C1 domain in the N-terminus and a C-terminal Rac-GAP domain, while the longer variants, α 2- and β 2-chimaerins, contain an additional Src homology 2 (SH2) domain in their N-terminus (Fig. 4). The C-terminal Rac-GAP domain is responsible for interactions with and selectivity for the Rac GTPase; it accelerates the hydrolysis of Rac-bound GTP thus leading to Rac inactivation (Caloca et al., 2003; Yang and Kazanietz, 2007).

The chimaerins bind phorbol esters in a C1 domain-dependent manner (Ahmed et al., 1990; Caloca et al., 1997). The binding properties of α -chimaerin C1 domain are virtually indistinguishable from PKC α in regarding their ligand-binding properties and phospholipid requirements (Arecas et al., 1994), while β 2-chimaerin exhibits different ligand selectivity compared with that of PKC α (Caloca et al., 1997). Exposure to phorbol esters or DAG analogues or stimulation of cells with epidermal growth factor induce redistribution of chimaerins from cytosol to the plasma membrane and to the Golgi (Caloca et al., 1997; Caloca et al., 1999; Caloca et al., 2001; Wang et al., 2006). However, the interaction of the β 2-chimaerin C1 domain with cellular membranes requires higher concentrations of DAG or phorbol esters than for example for PKC α (Caloca et al., 2001). This difference was explained by the crystal structure: the DAG binding site of β 2-chimaerin is concealed by interactions of the C1 domain with the N-terminus, the SH2 domain, the Rac-GAP domain and the SH2-C1 linker region (Canagarajah et al., 2004). Consistently, β 1-chimaerin, the splice variant lacking the SH2 domain, translocates to membranes at 60-fold lower phorbol ester concentrations than β 2-chimaerin due to fewer intramolecular interactions constraining its C1 domain.

The role of DAG seems to be more in targeting α 2- and β 2-chimaerins to the membrane than in activating them (Yang and Kazanietz, 2007). The functions of the shorter splice variants α 1- and β 1-chimaerins may, however, be regulated differently due to the lack of SH2 domain-mediated autoinhibition. Indeed, protein levels of α 1-chimaerin in neurons are actively controlled by proteasomal degradation: DAG signalling or exposure of neurons to phorbol esters stabilizes the protein, allowing α 1-chimaerin accumulation and thus enhancing chimaerin-mediated Rac inhibition (Marland et al., 2011).

The target of chimaerin actions, the small GTPase Rac, is a central regulator of actin cytoskeleton organization, cell migration, transformation, cell cycle progression and gene expression (Etienne-Manneville and Hall, 2002), and chimaerins participate in regulating these phenomena by inhibiting Rac activity in response to GPCR- or RTK-initiated DAG production. The α 1-, α 2- and β 2-chimaerins are highly expressed in the brain, while the expression of β 1-chimaerin is largely limited to testis (Yang and Kazanietz, 2007). The high expression levels in brain suggest that chimaerins play important roles in regulating Rac-mediated responses in the CNS. Indeed, α -chimaerins were recently shown to control neuronal migration and oculomotor axon guidance (Ip et al., 2011; Ferrario et al., 2012), and β 2-chimaerin was reported to be required for axonal pruning both *in vitro* and *in vivo* in hippocampus (Riccomagno et al., 2012). Earlier reports had already identified α 2- and β 2-chimaerins as effectors for ephrin receptors in the CNS (Beg et al., 2007; Takeuchi et al., 2009), and α 1-chimaerin had been reported to control dendritic pruning and morphology (Buttery et al., 2006). Outside the CNS, α 2- and β 2-chimaerins are expressed in various cell lines and in T cells, where they regulate T cell receptor signalling, adhesion and chemotaxis (Yang and Kazanietz, 2007).

2.3.6 Ras guanyl-releasing proteins (RasGRPs)

Ras guanyl-releasing proteins (RasGRPs; also known as CalDAG-GEFs) are a family of four guanine nucleotide exchange factors (GEFs) that activate Ras and related small GTPases by catalysing the exchange of GDP to GTP (Stone, 2011). They are characterized by a common domain structure: The N-terminal catalytic region consists of a Ras exchange motif (REM) and a RasGEF domain, and the C-terminal regulatory region contains two EF hand motifs and a single C1 domain (Fig. 4). The EF hand motifs of RasGRPs are homologous with calcium-binding EF hand motifs of other proteins, and the original report demonstrated that the RasGRP EF hand motifs also bind Ca^{2+} (Ebinu et al., 1998). However, they have also been reported to regulate plasma membrane association of RasGRPs together with the RasGEF domain in a Ca^{2+} -independent manner (Tazmini et al., 2009), and the role of Ca^{2+} in the control of RasGRP functions is thus unclear. The C1 domains of RasGRP isoforms 1, 3 and 4 are high-affinity receptors for phorbol esters and DAG, while the C1 domain of RasGRP2 is not, even though its sequence contains many of the amino acids critical for DAG/phorbol ester binding (Lorenzo et al., 2000; Johnson et al., 2007). Similarly, isoforms 1, 3 and 4 translocate to cellular membranes after DAG or PMA treatment, while RasGRP2 remains in the cytosol (Johnson et al., 2007).

The C1 domain-mediated membrane binding of RasGRPs 1, 3 and 4 seems to play a major role in their activation (Ebinu et al., 1998; Tognon et al., 1998; Reuther et al., 2002). Additionally, RasGRPs 1 and 3 are regulated by PKC-dependent phosphorylation (Teixeira et al., 2003; Roose et al., 2005). RasGRP4 contains a proline-rich region instead of the PKC phosphorylation sequence, and is therefore not phosphorylated by PKC (Zheng et al., 2005).

The functions of RasGRPs have been best characterized in the cells of the immune system. RasGRP1 is a central mediator of T cell receptor signalling (Dower et al., 2000; Ebinu et al., 2000), and indispensable for natural killer (NK) cell cytotoxicity and cytokine production (Lee et al., 2009). It also mediates B cell receptor signalling together with RasGRP3 (Coughlin et al., 2005). RasGRP4 is the only isoform expressed in mast cells, where it regulates prostaglandin D2 expression (Yang et al., 2002; Li et al., 2003). It has also been reported to mediate GPCR-mediated Ras activation in neutrophils (Suire et al., 2012). RasGRPs 1 and 3 are also expressed outside the immune system: RasGRP1 has been reported to exist in a subset of neurons (Toki et al., 2001) and RasGRP3 has been found in endothelial cells and some cancer cell lines (Yang et al., 2010; Randhawa et al., 2011; Yang et al., 2011). The exact roles of RasGRPs in these tissues and cells are however not clear.

2.4 Potential therapeutic indications for DAG effector-targeted drugs

As a consequence of the central role for DAG in mediating cellular signal transduction, PKC and other DAG effectors are important regulators of processes that contribute to pathophysiology of numerous important human diseases. PKC isoforms are implicated in cancer (Hofmann, 2004; Griner and Kazanietz, 2007), diabetes (Geraldine and King, 2010), cardiovascular diseases (Churchill et al., 2008), autoimmune diseases (Baier and Wagner, 2009), neurodegenerative diseases such as AD (Sun and Alkon, 2010) and stroke (Bright and Mochly-Rosen, 2005), among others. The other DAG effectors also mediate various pathophysiological processes. Reputed roles for DAG effectors in selected examples of such pathologies are presented below.

2.4.1 Cancer

Cancer is a large group of diseases, in which uncontrolled cell proliferation leads to formation of malignant tumours. It is one of the leading causes of death worldwide: an estimated 7.6 million cancer deaths occurred and 12.7 million new cancer cases were diagnosed in 2008 (Ferlay et al., 2010). In Finland approximately 28 000 people are diagnosed with cancer each year (Finnish Cancer Registry, 2013). Cancer arises when a single cell in a normal tissue progressively accumulates mutations that lead, first, to uncontrolled cell proliferation and inhibition of apoptosis. If the resulting malignant cells escape the immune response, they form a tumour, which is eventually becomes capable of invading to adjacent tissues and metastasizing via lymphatic or blood vessels to other sites of the body. These gained malignant properties result from disturbances in regulatory signalling pathways, which are normally under strict control. Protein kinases are examples of key regulators that are often deregulated in cancer cells (Blume-Jensen and Hunter, 2001).

The role of PKC in cancer development and progression has been extensively studied, since it was the first recognized receptor for the most potent tumour promoters known, the phorbol esters. PKC is known to co-operate with the oncogene *ras* during transformation and functional connections between PKC and several other oncogenes, such as *fos* and *myc*, have been identified (see Griner and Kazanietz, 2007). Mutations in PKC isoforms are rarely the cause of a cancer, but altered PKC expression has been observed in many cancers, such as breast, prostate, bladder, colon and brain cancers as well as leukaemia (reviewed in Hofmann, 2004; Griner and Kazanietz, 2007). However, the roles of individual isoforms and their relative contribution to the role of PKC in carcinogenesis seem to depend on the original tissue and the cell type. Depending on the cancer, individual PKC isoforms may be either up-regulated/down-regulated or activated/inhibited, and thus both PKC inhibitors and activators possess potential as anticancer agents. Of the DAG-responsive PKC isoforms, PKC ϵ has a well-established role as a tumour promoter and a transforming oncogene, and it also promotes tumour invasion and metastasis (Gorin and Pan, 2009). On the other hand, PKC δ is mostly considered a tumour suppressor, although exceptions do exist (see Jackson and Foster, 2004). The roles of other DAG-responsive PKC isoforms in cancer are more conflicting and depend on the cell type and the tissue of origin. The issue is further complicated by the fact that it is not always kinase activity that mediates the PKC-dependent response. For example, in glioma cells PKC α plays an essential pro-proliferative and pro-survival role independently of its catalytic activity (Cameron et al., 2008).

Due to decades of intensive research, a vast number of PKC-targeted compounds have been developed and many of them have also been studied in clinical trials. The most popular approach has been to target the catalytic site, and several ATP-competitive PKC inhibitors (such as midostaurin and enzastaurin) have been studied for their efficacy against cancer in clinical trials. They have, however, shown no remarkable efficacy either alone or in combination with other anti-cancer agents (Mackay and Twelves, 2007; Mochly-Rosen et al., 2012). The PKC α antisense oligonucleotide aprinocarsen reached phase III clinical trials, but due to lack of efficacy and serious toxicities, its development was discontinued (Mochly-Rosen et al., 2012). Additionally, multiple classes of C1 domain-targeted PKC modulators (see chapter 2.5) and peptides inhibiting PKC protein-protein interactions have been developed (reviewed in Churchill et al., 2009).

In addition to PKC, most of the other DAG effectors also play a role in regulating processes associated with cancer development (Table 1). PKD isoforms regulate many signalling pathways

associated with cell proliferation, motility, invasion, and angiogenesis, and are thus considered potential targets for cancer therapy (reviewed in Lavallo et al., 2010; Sundram et al., 2011). However, similarly to PKC, the role of PKD in cancer seems to depend on the isoform and on the cancer type studied. PKDs have been implicated for example in breast cancer, prostate cancer, gastrointestinal cancers, lung cancer and lymphoma. Of particular interest is the proposed role for PKD in pancreatic cancer, which is a devastatingly aggressive cancer with a poor prognosis (Guha et al., 2010). PKD1 protein levels were shown to be up-regulated in pancreatic ductal adenocarcinoma tissue when compared to normal pancreatic tissue (Trauzold et al., 2003). PKD1 overexpression also increased proliferation rate and prevented apoptosis of Colo357 pancreatic adenocarcinoma cells *in vitro*. Furthermore, the PKD inhibitor CRT0066101 inhibited pancreatic cancer cell proliferation and induced apoptosis *in vitro*, and inhibited pancreatic cancer growth *in vivo* in orthotopic and subcutaneous xenograft cancer models (Harikumar et al., 2010). Inhibition of PKD may thus be a useful therapeutic strategy in pancreatic cancer.

As activators of the oncogene Ras, RasGRPs are attractive cancer drug targets. Indeed, all of the DAG-responsive RasGRP isoforms 1, 3 and 4 have been associated with cancer. The gene encoding RasGRP1 functions as an oncogene in murine lymphomas and its deregulated expression induces transformation of thymocytes and initiates lymphoma in mice (Kim et al., 2003; Klinger et al., 2005). RasGRP1 has also been shown to mediate PMA-induced Ras activation in mouse keratinocytes and thus potentially contribute to phorbol ester-induced tumour promotion in the two-stage skin carcinogenesis model (Tuthill et al., 2006). Elevated RasGRP3 levels have been demonstrated to contribute to malignant phenotype of prostate cancer and melanoma cell lines *in vitro* and in mouse xenograft tumours (Yang et al., 2010; Yang et al., 2011). Moreover, RasGRP4 was initially discovered in a screen for transforming genes in acute myeloid leukaemia (Reuther et al., 2002). Conversely, a proapoptotic signalling pathway involving RasGRPs 1 and 3 in non-Hodgkin's B cell lymphoma cells has also been described (Stang et al., 2009).

Like RasGRPs, chimaerins also mediate their signals by regulating the activity of a small GTPase. However, since the chimaerins act to inhibit Rac, they are mainly considered tumour suppressors (Griner and Kazanietz, 2007; Yang and Kazanietz, 2007). Lower β 2-chimaerin expression levels have been reported in high-grade gliomas when compared with normal brain tissue or low-grade brain tumours (Yuan et al., 1995), and β 2-chimaerin mRNA transcript levels are also lower in breast cancer tissue compared with normal breast tissue from the same patients (Yang et al., 2005). Moreover, overexpression of β 2-chimaerin in cancer cell lines inhibits cell proliferation *in vitro* and *in vivo*, and reduces invasiveness of cancer cells *in vivo* (Yang et al., 2005). Activation or up-regulation of β 2-chimaerin could thus be beneficial in the treatment of cancer.

Although not much is known about the role of DAG-responsive DGKs in regulating processes related to cancer progression, as terminators of DAG signalling they are likely to contribute to both pro-survival and pro-apoptotic signalling. DGK β was identified as a survival kinase in HeLa cells in an RNA interference (RNAi) screen on human kinases and phosphatases (MacKeigan et al., 2005). DGK γ has been reported to positively regulate cell cycle progression in several cell lines (Matsubara et al., 2006). However, it has also been shown to activate β 2-chimaerin and thus it may function as a tumour suppressor (Yasuda et al., 2007; Sakane et al., 2008).

Based on the limited number of publications, the MRCKs seem to consistently promote tumour cell survival, proliferation and invasion. MRCK α was identified as a survival kinase in HeLa cells in a

kinome-wide RNAi screen (MacKeigan et al., 2005). Combined knock-down of MRCK α and MRCK β using RNAi inhibits invasion of colorectal cancer cells and breast cancer cells, and this combined with knock-down of ROCK further potentiates the anti-invasive effect (Wilkinson et al., 2005; Heikkilä et al., 2011). Furthermore, a combined knock-down of MRCKs and ROCK inhibits tumour development in mice injected with retrovirus-transformed keratinocytes (Lefort et al., 2007). The small GTPase Cdc42, upstream of MRCK, has also been implicated in cancer. Its effects are however complex and depend on the cell type (Stengel and Zheng, 2011).

Table 1. Roles of DAG effectors in cancer-related cellular processes.

DAG effector	Cellular response		Putative role in cancer	References
PKC	proliferation	↑↓	tumour promotion or	(Hofmann, 2004) ^a
	survival	↑↓	tumour suppression	(Jackson and Foster, 2004) ^a
	apoptosis	↑↓		(Gorin and Pan, 2009) ^a
	angiogenesis	↑		(Konopatskaya and Poole, 2010) ^a
	motility	↑		(Mochly-Rosen et al., 2012) ^a
PKD	proliferation	↑↓	tumour promotion or	(Trauzold et al., 2003)
	survival	↑↓	tumour suppression	(MacKeigan et al., 2005)
	apoptosis	↑↓	inhibition of invasion	(Eiseler et al., 2009)
	motility	↓		(Lavalle et al., 2010) ^a
	angiogenesis	↑		(Sundram et al., 2011) ^a
DGKs β and γ	survival	↑	tumour promotion or	(MacKeigan et al., 2005)
	proliferation	↑↓	tumour suppression	(Matsubara et al., 2006) (Yasuda et al., 2007) (Sakane et al., 2008) ^a
MRCK	survival	↑	tumour promotion and	(MacKeigan et al., 2005)
	motility	↑	invasion	(Wilkinson et al., 2005) (Lefort et al., 2007) (Heikkilä et al., 2011)
RasGRP	proliferation	↑	tumour promotion or	(Kim et al., 2003)
	survival	↑	tumour suppression	(Klinger et al., 2005)
	apoptosis	↑		(Stang et al., 2009) (Yang et al., 2010) (Yang et al., 2011)
Chimaerins	proliferation	↓	tumour suppression	(Yuan et al., 1995)
	invasiveness	↓		(Yang et al., 2005)
	motility	↓		(Maeda et al., 2006)
Munc13			not reported	

^a and references herein

2.4.2 Alzheimer's disease (AD)

AD is a progressive neurodegenerative disease that leads to severe impairment of memory and cognitive functions, alterations in behaviour, incapacity for independent living and, finally, death. It is the leading cause of dementia (Barker et al., 2002). According to an estimate 35.6 million people lived with dementia in 2010, and the numbers are expected to almost double approximately every 20 years, reaching 115 million in 2050 (Prince et al., 2013). Currently, there is no treatment that could cure or even inhibit the progression of AD, and therefore new disease-modifying therapies are needed.

The main neuropathological change characteristic to AD is the loss of neurons and synapses, in particular in cerebral cortex, hippocampus and other subcortical structures that contribute to

memory formation (Mann et al., 1986; Roh et al., 2011). The neuronal loss is a consequence of accumulation of predominantly extracellular β amyloid ($A\beta$) deposits (plaques) and intracellular neurofibrillary tangles consisting of hyperphosphorylated tau protein (Selkoe, 2001). Oxidative stress, microglia activation and inflammation also contribute to neuronal damage (Kitazawa et al., 2004). The amyloid plaques result from abnormal processing of the amyloid precursor protein (APP) and consequent accumulation and aggregation of β -amyloid peptides $A\beta_{1-40}$ and $A\beta_{1-42}$ (Selkoe, 2001). APP is processed by α -, β - and γ -secretases: cleavage by α -secretase and subsequently by γ -secretase produces the nontoxic soluble APP fragment (sAPP α) and the N-terminally truncated $A\beta$ (p3), which does not aggregate. By contrast, cleavage of APP first by β -secretase and thereafter by γ -secretase produces the pathogenic $A\beta_{1-40}$ and $A\beta_{1-42}$ that aggregate to form toxic oligomers and amyloid plaques. Intracellular neurofibrillary tangles result from hyperphosphorylation of tau protein, which normally functions to stabilize microtubules. Hyperphosphorylated tau aggregates and forms paired helical filaments, which build up the neurofibrillary tangles (Duff and Planel, 2005). According to the amyloid cascade hypothesis the amyloid pathology precedes tau-related pathology (Hardy and Higgins, 1992), but the issue is controversial and the initiating pathophysiological changes remain unresolved. However, strong evidence suggests that the synaptic dysfunction present prior to neuronal degeneration is caused by $A\beta$ oligomers (see Selkoe, 2002).

PKC is involved in synaptic neurotransmission and plays major roles in learning and memory (Sun and Alkon, 2010). Several PKC substrates, including myristoylated alanine-rich C-kinase substrate (MARCKS), growth-associated protein 43 (GAP-43) and the *N*-methyl-D-aspartate (NMDA) receptor, are involved in information processing and storage. PKC protein levels are reduced in the brains of AD patients and abnormal PKC signalling in the brain has been identified as an early change in AD as well as in memory deficits related to ischemia or stroke (Alkon et al., 2007; Sun and Alkon, 2010). Such changes include PKC translocation defects, reduced levels of PKC anchoring protein RACK1, and decreased PKC activity (Wang et al., 1994; Battaini et al., 1999).

PKC isoforms regulate several pathways relevant for AD pathophysiology *in vitro* and *in vivo* (Fig. 5) (Pascale et al., 2005; Hooper et al., 2008; Amadio et al., 2009; Kim et al., 2011). For example, PKC activation has been shown to direct APP processing to the non-pathogenic α -secretase pathway, thus increasing the production of neuroprotective sAPP α and reducing the production of neurotoxic $A\beta$ protein (Jacobsen et al., 1994; Etcheberrigaray et al., 2004). PKC activation also increases $A\beta$ clearance and reduces tau hyperphosphorylation (Isagawa et al., 2000; Kim et al., 2011). Furthermore, PKC has been shown to protect hippocampal neurons from $A\beta$ toxicity (Garrido et al., 2002). Additionally, PKC α phosphorylates and up-regulates nELAV (neuronal Embryonic Lethal Abnormal Vision) proteins, which regulate mRNA stability and translation (Pascale et al., 2005; Pascale et al., 2008). One of the target proteins of nELAVs is GAP-43, and both nELAVs and GAP-43 are up-regulated *in vivo* following PKC activation and during spatial learning (Quattrone et al., 2001; Pascale et al., 2004; Pascale et al., 2005). Neuronal ELAV proteins have also been implicated in AD pathology: nELAV levels are decreased in the brains of AD patients along with disease progression, and $A\beta_{1-42}$ causes nELAV down-regulation in SH-SY5Y neuroblastoma cells, thereby leading to down-regulation of ADAM10, the best-characterized α -secretase mediating non-amyloidogenic processing of APP (Amadio et al., 2009). For these numerous reasons PKC activators are considered potential future therapeutics for the treatment of AD (Sun and Alkon, 2010).

In addition to PKC, also Munc13s play a role in APP processing: α -secretase mediated processing of APP was impaired in the brains of Munc13-1 knock-out mice, and phorbol-induced sAPP α secretion

was less pronounced in brain slices of Munc13-1 knock-out mice than in wild type mice (Rossner et al., 2004). Consistently, phorbol ester-induced sAPP α secretion was only partially inhibited by the pan-PKC inhibitor Gö6983 in neuroblastoma cells, and overexpression of Munc13-1 augmented phorbol-induced increase of sAPP α secretion. Stimulation of postsynaptic glutamate receptors rescued the defective sAPP α secretion in organotypic brain slice cultures from Munc13 knock-out mice, implying that the defective APP processing results from the lack of postsynaptic glutamatergic stimulation (Hartlage-Rübsamen et al., 2013). Treatments that activate Munc13s may thus have potential in directing APP processing to the non-amyloidogenic α -secretase route.

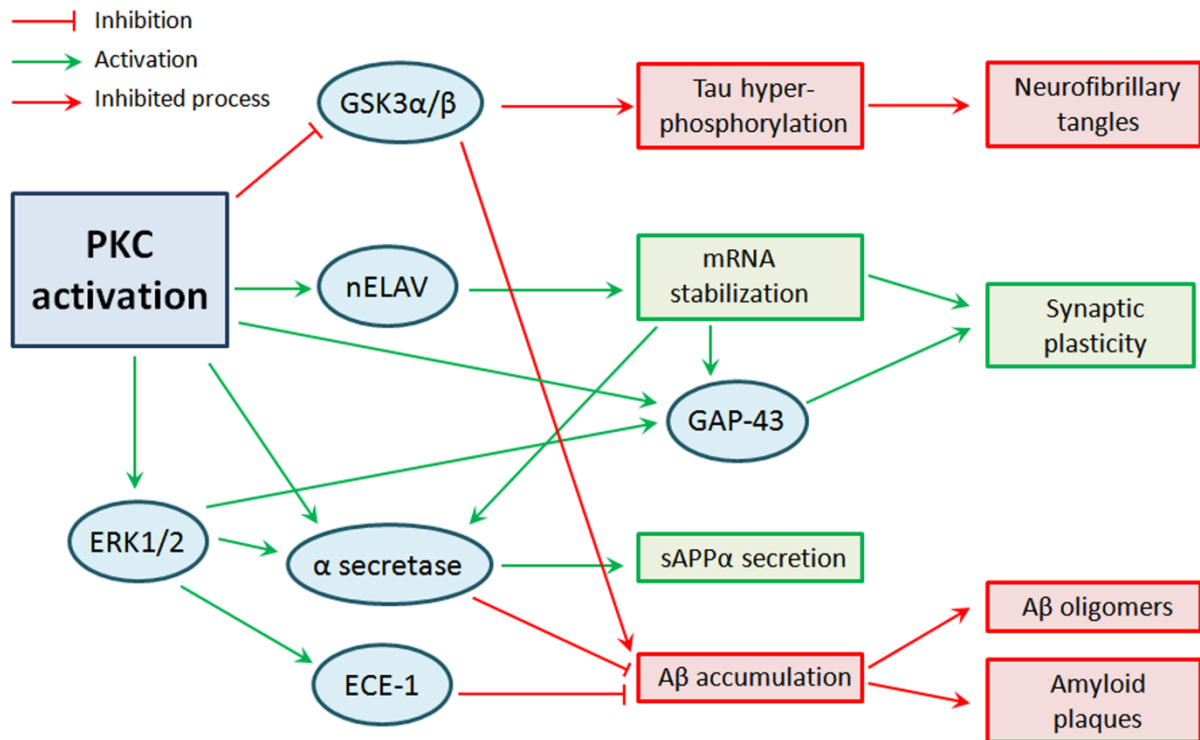

Figure 5. Postulated effects of PKC activation in Alzheimer's disease. Activation of PKC leads to: 1) inhibition of glycogen synthase kinase 3 (GSK3) activity, which in turn reduces hyperphosphorylation of tau protein and inhibits production of A β peptides; 2) phosphorylation and activation of nELAV proteins leading to stabilization of mRNAs and thereby positively influencing expression of genes (e.g. GAP-43 and the α -secretase ADAM10) that are important in neuritogenesis, memory formation and non-amyloidogenic APP processing; 3) increased processing of amyloid precursor protein (APP) via the α -secretase route leading to increased secretion of soluble and non-toxic sAPP α and decreased accumulation of neurotoxic β amyloid protein (A β); 4) activation of endothelin-converting enzyme 1 (ECE-1) which degrades A β . ERK1/2, extracellular signal-regulated kinase 1/2.

2.4.3 Other therapeutic indications

PKCs and other DAG effectors are also implicated in numerous other pathological conditions, such as cardiovascular diseases, immunological diseases and diabetes. Cardiovascular diseases are one of the leading causes of death world-wide. PKC isoforms have been implicated in numerous cardiac pathologies, such as myocardial infarction and ischaemia-reperfusion injury, cardiac arrhythmia, hypertension-induced compensatory hypertrophy and heart failure (Mochly-Rosen et al., 2012). The role of PKC however depends on the pathology and on the isoform. For example, in the ischaemic

heart activation of PKC δ mediates the acute myocardial injury, while activation of PKC ϵ exhibits a cardioprotective effect (Chen et al., 2001). By contrast, activation of PKC ϵ plays a pathological role during pathological compensatory cardiac hypertrophy and heart failure (Ferreira et al., 2011). Cardioprotective effects against pathological cardiac remodelling have been achieved in preclinical studies with PKC β and PKC ϵ inhibitors. Also PKD is implicated in cardiac diseases (reviewed in Avkiran et al., 2008). Particularly, PKD isoforms 1 and 3 mediate cardiac remodelling and hypertrophy in a cooperative manner by influencing distinct hypertrophic cardiac transcription factors. PKD1 is required for pathological cardiac remodelling and it regulates cardiomyocyte hypertrophy by phosphorylating HDACs that upon phosphorylation disengage from the transcription factor MEF2 (myocyte enhancer factor-2) leading to relieved transcription repression and subsequent foetal gene activation and cardiac hypertrophy (Fielitz et al., 2008). PKD3 increases the expression of cardiac transcription factors NFATc4 (nuclear factor of activated T cells 4), Nkx2.5 (homeobox protein Nkx-2.5) and GATA-4, and thereby activates foetal gene expression and cardiac remodelling (Li et al., 2011). Since there is no treatment available that could prevent the remodelling process, inhibition of PKC ϵ and/or PKD isoforms 1 and 3 possess potential as novel therapeutic strategies for pathological cardiac remodelling.

DAG is one of the key second messengers mediating immune cell signalling, and several families of DAG effectors, particularly PKC and RasGRPs, have been implicated in regulating immune responses (see Tan and Parker, 2003; Stone, 2011). Many PKC isoforms participate in controlling immune cell responses: PKC α plays a role in thymocyte maturation; PKC β regulates B cell survival; PKC δ controls B cell tolerance to self-antigens; and PKC ϵ mediates macrophage activation (Tan and Parker, 2003). In particular, PKC θ seems to be central for pathologic immune responses (e.g. autoimmunity), while being dispensable for beneficial immune responses such as protection against pathogen infection (reviewed in Zhang et al., 2013). Therefore it is considered a promising target for selective immunosuppressive therapy. RasGRPs 1 and 3 are implicated in B cell proliferation, RasGRP1 is an essential regulator of NK cell function, and RasGRP4 mediates eicosanoid production in mast cells (Stone, 2011). RasGRP4-null mice exhibit diminished inflammatory responses in experimental models of arthritis and colitis, and inhibition of RasGRP4 could thus be a potential therapeutic strategy for these diseases (Adachi et al., 2012).

Several PKC isoforms have been implicated in controlling insulin signalling and thus glucose homeostasis (Sampson and Cooper, 2006). Insulin receptor activation leads to activation of PKC, which may then regulate insulin signalling by phosphorylating e.g. the insulin receptor, insulin receptor substrate 1 (IRS-1), and GSK3. PKC may thus play a role in the development of insulin resistance (Turban and Hajduch, 2011). Furthermore, hyperglycaemia induces chronic activation of PKC isoforms, and this has been associated with development of pathological vascular complications such as atherosclerosis, nephropathy and retinopathy (Geraldes and King, 2010). The vascular complications are at least partially mediated by PKC β II, and the PKC β -selective inhibitor ruboxistaurin (LY333531) has proceeded to clinical trials against diabetic retinopathy and nephropathy (Geraldes and King, 2010). Although best known for their role in CNS, Munc13s also regulate insulin vesicle release from pancreatic β cells (Sheu et al., 2003). Insulin release from pancreatic islets of Munc13-1 null mice is severely impaired, and Munc13-1 levels are significantly reduced in pancreatic islets of type 2 diabetes patients (Kang et al., 2006; Ostenson et al., 2006). Activation of Munc13-1 may thus provide a means to restore defective insulin secretion in diabetes. Munc13s may also play a role in the development of diabetic nephropathy (Song et al., 1999).

2.5 C1 domain ligands

Since PKC and other DAG effectors participate in the pathophysiology of various severe diseases, the C1 domain is considered an attractive target for drug development. A vast amount of work has been carried out to find compounds that specifically target the DAG binding site (reviewed in Boije af Gennäs et al., 2011). The main classes of C1 domain ligands are presented in Figure 6.

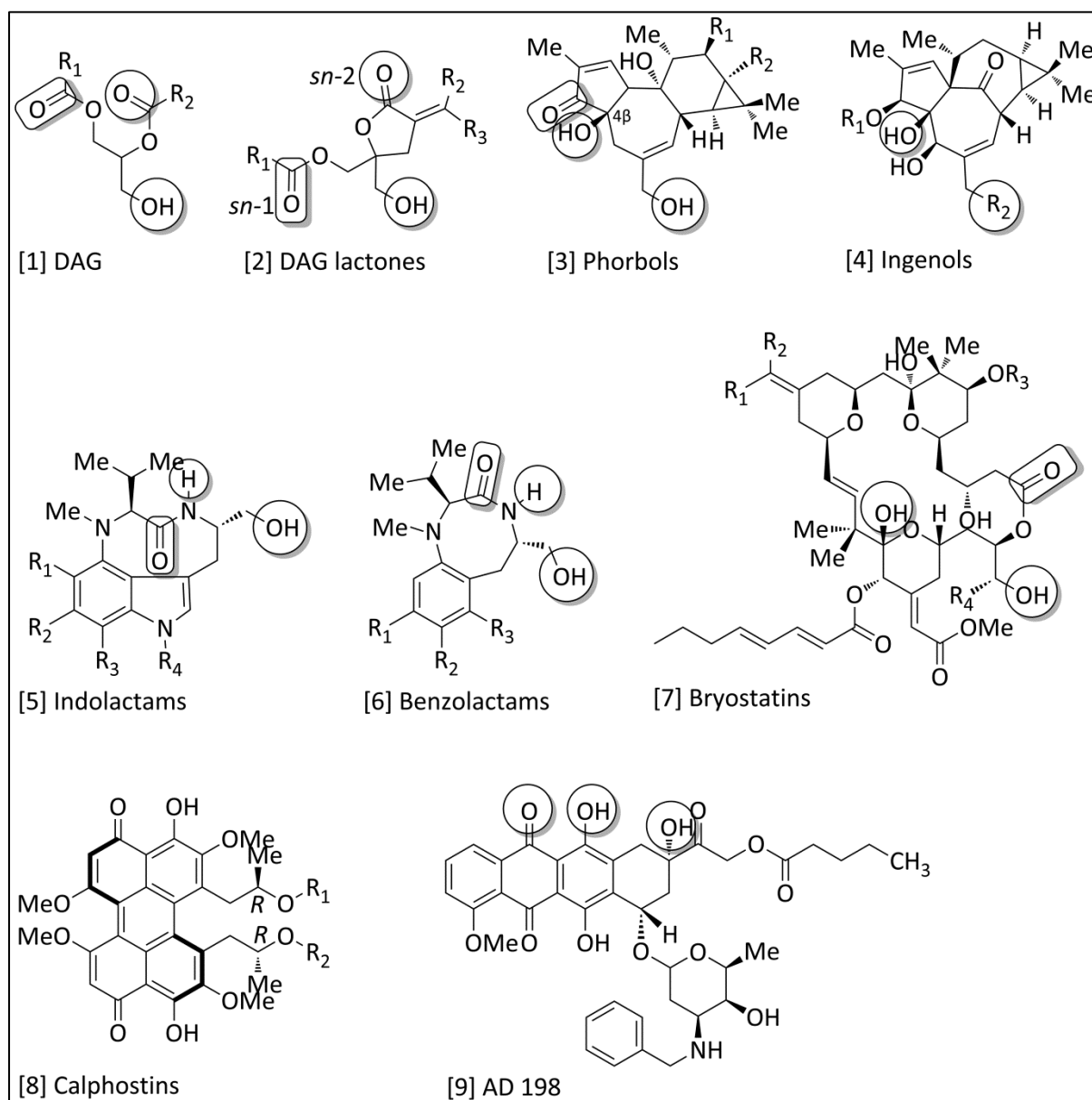

Figure 6. Structures of C1 domain ligands. Functional groups that interact with the C1 domain are circled.

2.5.1 Phorbol esters and phorbol derivatives

The most widely studied C1 domain ligands and PKC activators are phorbol esters ([3] in Fig. 6), tetracyclic diterpenoids that occur naturally in many plants of the families *Euphorbiaceae* and *Thymelaeaceae* (Goel et al., 2007). The two types of phorbol esters, the active (4 β) and the inactive

(4 α) differ only by the orientation of the hydroxyl group at position 4. The active β -phorbol esters bind to the C1 domains with high affinity and are extremely potent tumour promoters in the 2-stage mouse skin carcinogenesis model, while the inactive α -phorbol esters exhibit no affinity for the C1 domain and are devoid of tumour-promoting activity (van Duuren et al., 1979). The 4 β -phorbol esters compete with DAG upon binding to the C1 domain (Sharkey et al., 1984) and mimic the actions of DAG albeit with 3 orders of magnitude higher affinity. In contrast to DAG, phorbol ester-induced PKC activation is persistent and leads to down-regulation (see 2.2.3). PMA (also known as 12-*O*-tetradecanoylphorbol-13-acetate [TPA]) and PDBu are the best characterized tumour-promoting phorbol esters, and they have been used universally as prototypes of PKC activators and as research tools in elucidating physiological and pathophysiological roles of PKCs and other DAG effectors. Furthermore, the binding affinities of other C1 domain ligands are generally measured as their ability to displace tritiated PDBu ($[^3\text{H}]\text{PDBu}$), which binds to cPKC and nPKC isoforms with K_d values in the range of 0.15-0.94 nM (Kazanietz et al., 1993).

Despite their tumour-promoting activity, phorbol esters have antiproliferative, differentiating and proapoptotic effects in various cancer cell lines (Rovera et al., 1979; Day et al., 1994; Troll r et al., 2001; Afrasiabi et al., 2008). The effects of PMA have even been studied in a clinical setting in patients with myelocytic leukaemia with some short-term therapeutic effects (Han et al., 1998). In addition to phorbol diesters, several other phorbol derivatives also bind to the C1 domain. Of these, prostratin (12-deoxyphorbol-13-acetate) and DPP (12-deoxyphorbol-13-phenylacetate) are non-tumour-promoting phorbol derivatives that also activate PKCs and exhibit potent *in vitro* efficacy in the activation of latent HIV reservoirs and thus represent promising adjuvants for antiretroviral therapy (Kulkosky et al., 2001; Wender et al., 2008).

2.5.2 Bryostatins and their synthetic analogues

Bryostatins ([7] in Fig. 6), natural products originally isolated from the marine bryozoan *Bugula neritina*, but actually produced by its symbiont bacteria, are a family of at least 20 macrocyclic lactones (Mutter and Wills, 2000; Davidson et al., 2001). Bryostatin 1 is the best-characterized member of the family, with nanomolar affinity for the C1 domains of PKC ($K_i=1.35$ nM for PKC α) (Kazanietz et al., 1994). It binds to and activates classical and novel PKC isoforms without considerable isoform selectivity. It has also been reported to activate PKD (Matthews et al., 1997), to bind to and modulate RasGRPs (Lorenzo et al., 2000; Tuthill et al., 2006), and to bind to $\beta 2$ -chimaerin and induce its translocation (Caloca et al., 1997; Caloca et al., 2001).

Despite being a potent PKC activator, bryostatin 1 does not mimic all phorbol ester-induced responses in cellular models. Instead, it often antagonizes such phorbol-induced effects that it does not elicit (Kraft et al., 1986; Sz ll si et al., 1994a; Tuthill et al., 2006). Most importantly, bryostatin 1 is totally devoid of tumour-promoting activity and even antagonizes phorbol ester-induced tumour-promotion (Hennings et al., 1987). The opposing cellular responses to phorbol esters and bryostatins may be explained by their diverging effects on PKCs in cellular context. The patterns of down-regulation of individual PKC isoforms are different between bryostatin 1 and phorbol esters (Sz ll si et al., 1994b; Choi et al., 2006). Bryostatin 1-induced translocation of PKC δ is dependent on both C1a and C1b domains, while phorbol ester-induced PKC δ translocation requires only the C1b domain (B gi et al., 1998). Moreover, typical of bryostatin 1 are its biphasic concentration-dependent effects

in many biological responses such as PKC δ down-regulation and PKD activation (Szállási et al., 1994a; Matthews et al., 1997).

Bryostatin 1 exhibits characteristic anticancer effects in many experimental *in vitro* and *in vivo* models of cancer: it inhibits tumour growth and invasion (reviewed in Clamp and Jayson, 2002), but also stimulation of proliferation and antiapoptotic effects have also been reported (Choi et al., 2006). However, the numerous phase I and phase II clinical trials against many types of cancer, both alone and as a combination therapy with other antineoplastic agents, have shown only modest responses to bryostatin 1 (Clamp and Jayson, 2002). As a non-tumour-promoting PKC activator bryostatin 1 also possesses potential in the treatment of AD: it has been reported to enhance secretion of sAPP α both *in vitro* and *in vivo*, to reduce levels of pathologic A β fragments in brains of transgenic AD mice, and to reduce premature mortality of AD mice (Etcheberrigaray et al., 2004). Furthermore, bryostatin 1 has shown promising neuroprotective and neurorestorative efficacy in a rat model of cerebral ischemia, and it may thus have potential in the treatment of e.g. ischemic stroke (Sun et al., 2009). However, no clinical trials in these indications have been reported.

Because of the complex chemical structure of bryostatins and their scarceness in the natural material, synthetic bryostatin analogues, “bryologues”, with varying affinities and selectivity for PKC isoforms and individual C1 domains have been developed (Wender et al., 1999; Wender et al., 2011). Some bryologues have shown potential as anticancer agents and some show promise as activators of latent HIV reservoirs in the eradication of HIV (Stone et al., 2004; DeChristopher et al., 2012).

2.5.2 Ingenol derivatives

Ingenol derivatives ([4] in Fig. 6) are tumour-promoting macrocyclic diterpenes that are structurally closely related to phorbol esters (Nakamura et al., 1989; Boije af Gennäs et al., 2011). Ingenol-3-angelate (PEP005, ingenol mebutate) is the most studied ingenol derivative initially extracted from the sap of the plant *Euphorbia peplus*. It binds to the PKC C1 domains with subnanomolar affinity and shows no selectivity for individual PKC isoforms *in vitro* (Kedei et al., 2004). Patterns of PKC isoform translocation and down-regulation induced by ingenol-3-angelate differ from those induced by PMA, sometimes in a cell line-dependent manner (Kedei et al., 2004; Hampson et al., 2005).

Ingenol-3-angelate inhibits proliferation of various cancer cell lines and primary acute myeloid leukaemia (AML) cells (Gillespie et al., 2004; Kedei et al., 2004; Hampson et al., 2005). In leukemic cell lines and primary AML cells, it induces apoptosis by activating PKC δ and by subsequently inducing sustained activation of ERK1/2 (Hampson et al., 2005; Hampson et al., 2010). In contrast to its apoptosis-inducing effect in leukemic cells, it promotes survival of resting and activated human T cells by activating PKC θ (Lee et al., 2010).

Ingenol-3-angelate has undergone numerous clinical trials as topical treatment for actinic skin keratosis (a preliminary stage of squamous cell carcinoma) and for superficial basal cell carcinoma (Martin and Swanson, 2013), and it has recently been approved by the U.S. Food and Drug Administration (FDA) and by the European Medicines Agency (EMA) for the treatment of actinic keratosis (EMA, 2012; FDA, 2012). Its efficacy in other potential indications, such as non-melanoma skin cancers and leukaemia remains to be elucidated.

2.5.3 DAG lactones

DAG lactones ([2] in Fig. 6) are synthetic analogues of endogenous DAG with conformationally constrained backbones to surmount the entropic penalty caused by the flexible DAG structure (Marquez and Blumberg, 2003). They also contain lipophilic side chains that improve their interactions with the conserved lipophilic amino acid residues in the DAG binding cleft of the C1 domain. The most potent DAG lactones displace [³H]PDBu from PKC C1 domains with K_i values lower than 10 nM (Nacro et al., 2000; Marquez and Blumberg, 2003; Comin et al., 2009), and the remarkable series of derivatives also includes some compounds with moderate selectivity for individual PKC isoforms (Pu et al., 2005; Comin et al., 2009). Furthermore, by carefully balancing the lipophilicity and hydrophilicity of the acyl fragments for the DAG-lactones, a 100-fold selectivity for RasGRP ($K_i=0.18$ nM) over PKC α ($K_i=39.7$ nM) was achieved (El Kazzouli et al., 2008). A DAG lactone has also been shown to bind to the C1 domains of MRCK α and β , although only at significantly higher concentrations (K_i values of 23 μ M and 26 μ M for α and β isoforms, respectively) than to PKC C1 domains (Choi et al., 2008).

Various DAG lactones have shown antiproliferative and proapoptotic effects in several cancer cell lines *in vitro* (Garcia-Bermejo et al., 2002; Duan et al., 2008; Kang et al., 2010), and at least two of them potentiated the anti-cancer effect of γ irradiation in the orthotopic prostate cancer model in mice (Duan et al., 2008; Truman et al., 2009). Some of the DAG lactones have also been demonstrated to direct APP processing into the non-pathologic α secretase route by activating PKC (Lee et al., 2006; Duan et al., 2008). Besides their potential in drug development, the DAG lactone template has been a powerful research tool, and DAG lactones have been used in extensive studies exploring ligand-C1 domain interactions and interactions of the ligand-C1 domain complex with cellular membranes, thus providing useful information for the design of novel C1 domain ligands (see, for example, Nacro et al., 2000; Pu et al., 2005; Choi et al., 2007; Comin et al., 2009).

2.5.4 Indolactams and benzolactams

The tumour-promoting indole alkaloids of the teleocidin family were first isolated from *Streptomyces mediocidicus*, and subsequently shown to bind to the same receptors as phorbol esters (see Boije af Gennäs et al., 2011). The structurally simplest member of the family, (-)-indolactam V is a weak tumour promoter, and it has been used as a starting point to synthesize new derivatives with indolactam and benzolactam structures ([5] and [6] in Fig. 6, respectively) that bind the C1 domains of PKCs with low nanomolar affinities (Endo et al., 1996; Kozikowski et al., 1997; Nakagawa et al., 1998; Irie et al., 2005; Nakagawa et al., 2006). Extensive structure-activity studies have revealed derivatives with some selectivity for certain PKC isoforms (Kozikowski et al., 1997; Nakagawa et al., 2006). However, increased selectivity has only been achieved at the cost of binding affinity. Like many PKC-activating C1 domain ligands, indolactams and benzolactams induce PKC translocation and down-regulation (Kozikowski et al., 1997; Nakagawa et al., 2006). They have also been shown to bind to the C1 domains of RasGRPs, PKD, phorbol-responsive DGKs, Munc13 and chimaerins (Caloca et al., 2001; Rong et al., 2002; Irie et al., 2004).

Indolactam and benzolactam derivatives have been reported to inhibit proliferation of several cancer cell lines (Kozikowski et al., 1997; Endo et al., 1998). Benzolactam derivatives have also shown potential efficacy in cell-based models of Alzheimer's disease as measured by APP processing and secretion of sAPP α (Ibarreta et al., 1999), as well as *in vivo* in a transgenic mouse model of AD

(Etcheberrigaray et al., 2004). However, the efficacy of a benzolactam derivative, TPPB [(2S,5S)-(E,E)-8-(5-(4-(trifluoromethyl) phenyl)-2,4-pentadienoylamino)benzolactam], and bryostatin 1 was recently compared in a SH-SY5Y neuroblastoma cell-based model, and bryostatin 1 was found to be 10–100 times more potent than TPPB in activating the α -secretase pathway of APP processing (Yi et al., 2012). The difference in potency was estimated to be due to lower potency of TPPB in activating PKC isoforms δ and ϵ . Furthermore, (–)-indolactam V has been identified as an inducer of human embryonic stem cell differentiation to the pancreatic lineage (Chen et al., 2009). The effect is at least partly mediated by PKC activation, and the discovery may provide a means to produce insulin-secreting pancreatic β cells for cell replacement therapy in diabetes mellitus with the help of small molecules.

2.5.5 Other C1 domain ligands

Calphostin C ([8] in Fig. 6) is a polycyclic aromatic perylenequinone originally isolated from the fungus *Cladosporium cladosporioides*. It inhibits PKC in a light-dependent manner (Chiarini et al., 2010) and it has been reported to bind to the active conformation of PKC and target the C1 domain (Rotenberg et al., 1995). The mechanism seems to involve an irreversible oxidative modification of PKC that leads to a conformational change that inhibits both phorbol ester binding and phosphotransferase activity (Gopalakrishna et al., 1992a). It has also been shown to inhibit DGK activity (Redman et al., 1995) and to inhibit [3 H]PDBu binding to the C1 domains of RasGRP, β -chimaerin and Unc-13 (Arecas et al., 1994; Kazanietz et al., 1995; Lorenzo et al., 2000). Calphostin C exhibits proapoptotic effects in several cancer cell lines and it has been proposed to be a candidate for photodynamic cancer therapy; however, growing body of evidence suggests that the mechanism of action mediating calphostin C-mediated cytotoxicity is independent of PKC (Gopalakrishna et al., 1992a; Chiarini et al., 2010). Moreover, there are few or no reports describing its effects in *in vivo* cancer models.

N-benzyladriamycin-14-valerate (AD 198; [9] in Fig. 6), a semisynthetic anthracycline derivative developed to overcome doxorubicin resistance, exhibits its cytotoxicity at least partially by modulating PKC. It binds to the phorbol ester binding groove within the C1 domain, although not as deeply as phorbol esters (Roaten et al., 2001), while the parent compound doxorubicin or the primary metabolite, AD288, exhibit no affinity for the C1 domain. It has been shown to displace [3 H]PDBu from rat brain PKC, PKC δ , the C1b domain of PKC δ as well as the from C1 domain of β 2-chimaerin (Roaten et al., 2002). Although AD198 was shown to inhibit PKC activity *in vitro* (Roaten et al., 2002), the majority of reports suggest that in cellular context it functions as a PKC activator. It activates PKC δ and triggers the mitochondrial apoptotic cascade (He et al., 2005) thus inducing apoptosis in several treatment-resistant cancer cell lines (Harstrick et al., 1995; Lothstein et al., 2007). Furthermore, in contrast to cardiotoxic doxorubicin, it exhibits cardioprotective properties by activating PKC ϵ (Hofmann et al., 2007).

Other nature-derived C1 domain ligands include the tumour-promoting aplysiatoxins, debromoaplysiatoxins, iridals, resveratrol and curcumin (Boije af Gennäs et al., 2011). Recently described synthetic C1 domain ligands include diacyltetrol lipids (Mamidi et al., 2012a) and curcumin derivatives alkyl cinnamates (Mamidi et al., 2012b).

3. AIMS OF THE STUDY

The mitogenic signalling mediated by DAG and the contribution of DAG effectors in the control of cell proliferation, survival, death, morphology, differentiation, and motility makes PKC and several other DAG effectors attractive cancer drug targets. Furthermore, the role of PKC isoforms in central nervous system, especially in the regulation of memory and learning, speaks for their potential as drug targets for neurological and neurodegenerative diseases. Many classes of compounds targeted to the DAG binding site, the C1 domain, have been discovered. However, the chemical structures of most C1 domain ligands are extremely complex and therefore there is a need for simple, easily synthesisable C1 domain ligands. In this context, this PhD project aimed at characterizing a group of novel C1 domain ligands, derivatives of 5-(hydroxymethyl)isophthalic acid, *in vitro* and in HeLa and SH-SY5Y cells. More specifically, the aims were:

- To resolve the structure-activity relationships of the isophthalate template and to characterize the affinity of the compounds for different PKC isoforms as well as for other DAG effectors (I, III).
- To characterize effects of the isophthalates on cell viability, proliferation and morphology using HeLa cervical cancer cells (II, III).
- To investigate the effects of isophthalate derivatives on cell differentiation and PKC signalling in SH-SY5Y neuroblastoma cells (IV).

4. MATERIALS AND METHODS

This chapter describes the materials and methods used the studies presented. More detailed descriptions are given in the respective original publications I–IV.

4.1 Drugs

Isophthalic acid derivatives were designed and synthesized at the Division of Pharmaceutical Chemistry, University of Helsinki (Helsinki, Finland). Molecular modelling was performed using the X-ray crystal structure of PKC δ C1b domain (Zhang et al., 1995) as described in I, and the compounds were synthesized as described in I and IV. Stock solutions (10–100 mM) were prepared in dimethyl sulfoxide (DMSO; esters) or in 50% DMSO in H₂O (amides) and stored at -20 °C. The structures of isophthalate derivatives discussed in this thesis are presented in Figure 7.

The pan-caspase inhibitor Boc-Asp(OMe) fluoromethyl ketone (BAF), PDBu, PMA, bryostatin 1, the MEK inhibitor U0126 and chelerythrine chloride were purchased from Sigma-Aldrich (Steinheim, Germany). The pan-PKC inhibitor Gö6983 and the cPKC inhibitor Gö6976 were acquired from Calbiochem (EMD Millipore Corporation, Billerica, MA, USA), and the PKD inhibitor CID755673 was bought from Millipore (Merck Millipore, Dundee, UK). All drugs were dissolved in DMSO, except for chelerythrine chloride, which was dissolved in 50% DMSO in H₂O, and stored at -20 °C.

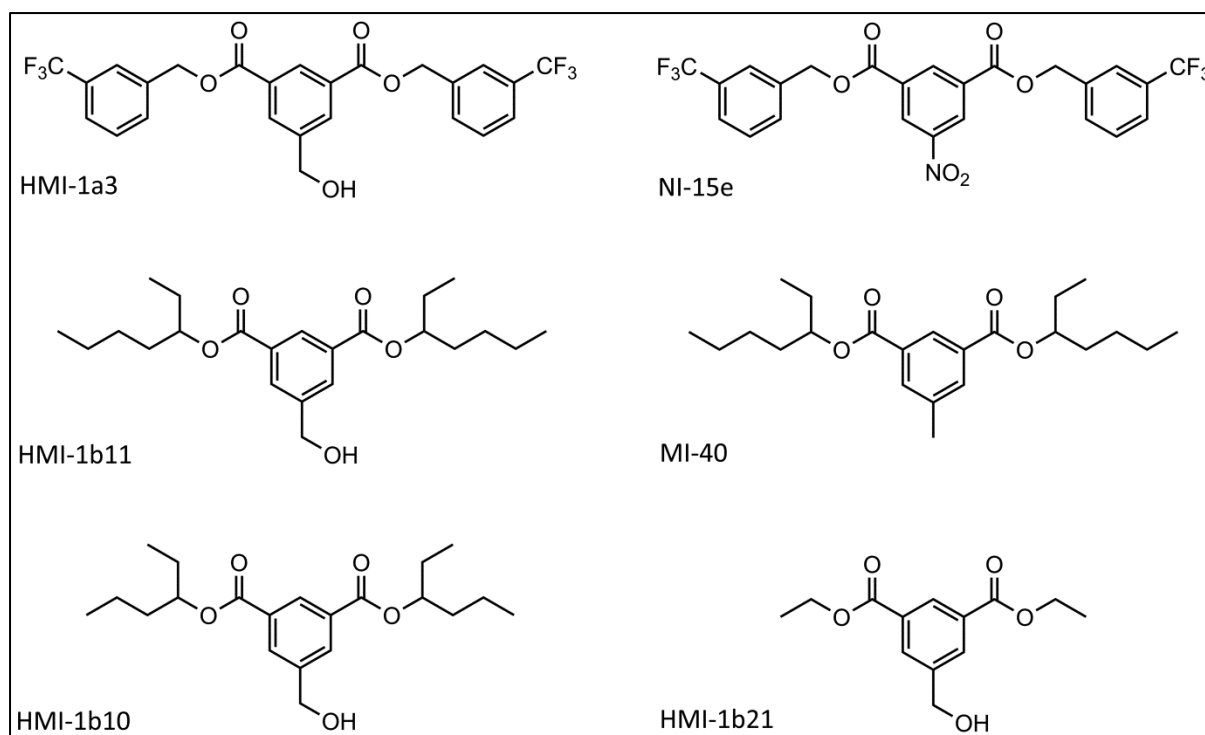

Figure 7. Structures of selected isophthalate derivatives.

4.2 Production and purification of recombinant proteins

4.2.1 Production of PKC α , PKC δ and β 2-chimaerin in Sf9 insect cells (I, III)

Recombinant human PKC α , PKC δ and β 2-chimaerin were produced in *Spodoptera frugiperda* Sf9 cells (Invitrogen, Carlsbad, CA, USA) using Bac-to-bac[®] baculovirus expression system (Invitrogen) with previously cloned expression vectors for PKC α and PKC δ (Tammela et al., 2004; Sandler et al., 2005). The plasmid for β 2-chimaerin expression was a gift from prof. Marcelo G. Kazanietz (University of Pennsylvania, Philadelphia, PA, USA) (Caloca et al., 1997). For production of recombinant PKC and chimaerin proteins, Sf9 cells were infected with an optimized amount of the recombinant baculovirus, harvested 2 days postinfection, washed with phosphate-buffered saline (PBS) and frozen at -20 °C.

4.2.2 Preparation of Sf9 cell homogenates (I, III)

Crude lysates were prepared by suspending melted Sf9 cell pellets in lysis buffer [25 mM Tris-HCl pH 7.5, 0.5 mM ethylene glycol tetraacetic acid (EGTA), 0.1% Triton-X 100] supplemented with protease inhibitors (Complete Protease Inhibitor Cocktail; Roche, Mannheim, Germany) and by incubating them on ice for 30 min. The lysates were then centrifuged (16000 *g*, 15 min, 4 °C) and the supernatants were collected. The protein content was determined according to Bradford (Bradford, 1976) and the supernatants were used for [³H]PDBu binding experiments.

4.2.3 Production of the C1 domain of MRCK α in *E. coli* (III)

The pGEX plasmid encoding the glutathione S-transferase (GST)-fused C1 domain of MRCK α was a gift from prof. Peter M. Blumberg (Center for Cancer Research, NCI, Bethesda, MD, USA) (Choi et al., 2008). Competent *E. coli* cells (strain BL21) were transfected with the plasmid and grown overnight at 37 °C on ampicillin-containing Luria Bertani agar plates. Ampicillin-resistant colonies were picked and grown overnight at 37 °C in Luria Bertani medium supplemented with 100 μ g/ml ampicillin. Large-scale cultures were set up the next day and the expression of recombinant protein was induced when the optical density of the medium containing bacteria had reached 0.5–0.6. For induction, isopropyl-*O*-d-thiogalactopyranoside (Sigma-Aldrich) was added to a final concentration of 0.5 mM and the bacteria were grown for 4 h at 37 °C. The bacteria were then harvested, washed twice with PBS, frozen and stored at -70 °C until purification.

4.2.4 Purification the C1 domain of MRCK α (III)

The frozen pellets of *E. coli* were thawed and suspended into lysis buffer (Tris-HCl 20 mM pH 7.8, 50 mM NaCl, 1% Triton X-100, 0.5% Igepal, 2 mM ethylenediaminetetraacetic acid (EDTA), 2 mM EGTA, 1 mM dithiothreitol, 2 mM phenylmethanesulfonylfluoride). Cell suspensions were incubated on ice for 30 min and cells were disrupted by two passes with French press. After centrifugation (11200 *g*, 30 min, 4 °C) the supernatant was incubated with glutathione beads (Sigma-Aldrich) for 2 h at 4 °C. Beads were then washed and bound proteins were eluted at 4 °C with lysis buffer containing 10 mM reduced L-glutathione (from Sigma-Aldrich).

4.3 Phorbol ester displacement assays

The ability of the compounds to compete with radioactively labelled PDBu for binding to the C1 domain of PKC α and δ was determined using two modifications of the binding assay. The initial testing for all compounds was performed with a 96-well plate filtration assay (Gopalakrishna et al., 1992b) using cell homogenates from Sf9 cells overexpressing recombinant human PKC isoforms. The filtration method was also used in binding studies with β 2-chimaerin and MRCK α . Binding affinity constants were determined using commercial purified recombinant human PKC isoforms α and δ (Invitrogen, Carlsbad, CA, USA) and the centrifugation method (Lewin and Blumberg, 2003). Binding of HMI-1a3 to PKD was similarly determined using commercial purified PKC μ /PKD1 (Merck Millipore, Dundee, UK) and the centrifugation method. [20- 3 H]Phorbol-12,13-dibutyrate ([3 H]PDBu) was acquired from Amersham Radiolabeling Service (GE Healthcare, Little Chalfont, UK).

4.3.1 Filtration method for [3 H]PDBu binding (I, III, IV)

Twenty micrograms of protein from homogenates of Sf9 cells overexpressing PKC α , PKC δ or β 2-chimaerin, or 40 ng of purified MRCK α C1 domain was incubated with test compounds and [3 H]PDBu for 10 min at RT in a 96-well Durapore filter plate (Millipore, Bedford, MA, USA). The final volume was 125 μ l and the concentrations in the reaction mixture were as follows: 20 mM Tris-HCl (pH 7.5), 40 μ M CaCl $_2$, 10 mM MgCl $_2$, 400 μ g/ml bovine IgG, 25 nM [3 H]PDBu, and 0.1 mg/ml phosphatidyl-L-serine. Proteins were precipitated by the addition of 125 μ l of cold 20% poly(ethylene glycol) 6000, and after a 15-min incubation on a plate shaker at RT the filters were washed and the plates were dried. Liquid scintillant was then added and radioactivity was measured using Wallac Microbeta Trilux microplate liquid scintillation counter (PerkinElmer, Waltham, MA, USA). Half maximal inhibitory concentrations (IC $_{50}$) were calculated with GraphPad Prism 4 software (GraphPad Software Inc., La Jolla, USA).

4.3.2 Centrifugation method for [3 H]PDBu binding (I, III)

Purified human recombinant PKC α , PKC δ or PKC μ /PKD1 (20 ng/tube) was incubated with test compounds for 10 min at 37 °C in a reaction mixture consisting of 50 mM Tris-HCl (pH 7.4), 0.1 mg/ml phosphatidyl-L-serine, 1.8 mg/ml bovine IgG, 25 nM [3 H]PDBu, and 0.1 mM CaCl $_2$ (for PKC α) or 1 mM EGTA (for PKC δ). Samples were chilled on ice for 10 min, and 200 μ l of 35% poly(ethylene glycol) 6000 in 50 mM Tris-HCl (pH 7.4) was added. The samples were mixed, incubated on ice for 15 min, and centrifuged (15000 *g*, 15 min, 4 °C). Radioactivity was determined from 100 μ l aliquots of supernatants and from dried pellets. The dissociation constants (K_d) for the individual PKC isoenzymes, the IC $_{50}$ values and the inhibitory dissociation constants (K_i) for the compounds were calculated with GraphPad Prism4 software.

4.4 Cell culture (I-IV)

Cell culture solutions and reagents were from Invitrogen, unless otherwise stated. Human cervical adenocarcinoma cell line HeLa (CCL-2) was acquired from American Type Culture Collection (ATCC,

Manassas, VA, USA) and cultured in Dulbecco's modified Eagle's medium (DMEM; from Sigma-Aldrich) supplemented with 10% foetal bovine serum (FBS), 100 U/ml of penicillin, and 100 µg/ml of streptomycin. Human neuroblastoma SH-SY5Y cells (CRL-2266; from ATCC) were cultured in DMEM/Ham's F-12 (1:1) medium supplemented with 15% FBS, 1% non-essential amino acids, 100 U/ml of penicillin, and 100 µg/ml of streptomycin. All cell cultures were maintained at 37 °C in a humidified atmosphere of 5% CO₂ and 95% air and verified negative for mycoplasma using MycoAlert® Mycoplasma detection Kit (Lonza, Verviers, Belgium).

4.4.1 RNA interference (III)

RNAi was used to knock down PKC isoforms α and δ in order to evaluate their role in mediating isophthalate-induced effects in HeLa cells. HeLa cells were seeded onto 12-well plates (2×10^5 cells/well) and transfected the next day with small interfering RNA (siRNA) constructs (ON-TARGETplus SMARTpool PRKCA for PKC α , ON-TARGETplus SMARTpool PRKCD for PKC δ , or the scrambled siRNA ON-TARGETplus siCONTROL non-targeting pool; all from Dharmacon RNA technologies, Lafayette, CO, USA) using X-tremeGENE transfection reagent (Roche). Cells were detached after 4 h, seeded onto 48-well plates (2500 cells/well) and grown for 3 days preceding drug treatments to allow for optimal silencing of target genes. Cells were then exposed to HMI-1a3 and imaged with Cell-IQ® as described in section 4.5.4. Down-regulation of PKC α and PKC δ expression was verified using Western blotting from cells harvested 1, 2, 3 and 6 days after siRNA transfection.

4.5 Cell viability and proliferation assays

For studying the effects of isophthalate derivatives on HeLa or SH-SY5Y cell viability, proliferation and morphology, several assays were used: the lactate dehydrogenase (LDH) assay was used to assess cell membrane integrity and the 3-(4,5-dimethylthiazol-2-yl)-2,5-diphenyltetrazolium bromide (MTT) assay was used to study mitochondrial reduction capacity of the cells (corresponding to both cell viability and proliferation). The rate of DNA synthesis was assessed by measuring the incorporation of [methyl-³H]thymidine into the DNA of HeLa cells. Furthermore, cell proliferation and morphology of both cell lines were studied by using a continuous cell culturing platform with integrated optics and computer vision technology (Cell-IQ®, CM Technologies Ltd, Tampere, Finland) (Toimela et al., 2008). All drug exposures were conducted in normal culture medium to provide optimal growth conditions for the cells.

4.5.1 LDH assay (II)

HeLa cells were seeded onto 96-well plates (10 000 cells/well) 16–24 hours before drug treatments to allow attachment. After drug exposures, 50 µl of medium from each well was transferred onto a new 96-well plate followed by addition of 50 µl/well of substrate solution [1.3 mM β -nicotinamide-adenine dinucleotide, 660 µM iodonitrotetrazolium, 54 mM L(+)-lactic acid, 280 µM phenazine methosulfate, 0.2 M Tris-HCl (pH 8.2)]. Plates were gently shaken for 10 min and incubated for another 20 min at RT, whereafter 50 µl of 1 M acetic acid was added to stop the reaction and absorbance was measured at 490 nm.

4.5.2 MTT assay (II, III)

HeLa cells were seeded onto 96-well plates (10 000 cells/well) 16–24 hours before drug treatments. After exposure to test compounds, MTT was added to the cells to a final concentration of 0.5 mg/ml. Plates were then incubated for 2 h at 37 °C in a humidified 5%-CO₂ atmosphere, whereafter the medium was aspirated and 200 µl of DMSO was added to each well. Absorbance was measured at 550 nm with absorbance at 650 nm extracted as background.

4.5.3 Thymidine incorporation assay (II)

HeLa cells were seeded onto 6-well plates (4 x 10⁵ cells/well) and let to attach for 16 h. Cells were then exposed to test compounds, and 0.5 µCi/ml [methyl-³H]thymidine was added to the medium for the last 6 h of the drug exposure. The cells were then washed three times with cold PBS, ice-cold 5% trichloroacetic acid was added and plates were incubated on ice for 10 min to extract residual thymidine. The trichloroacetic acid solution was discarded, cells were lysed with 0.1 M NaOH and radioactivity was measured by liquid scintillation counting.

4.5.4 Cell proliferation and morphology analysis with Cell-IQ® (II, III, IV)

HeLa cells (5000 cells/well) or SH-SY5Y cells (7500 cells/well) were seeded onto Nunc® 48-well plates (Thermo Scientific, Rockford, IL, USA) and allowed to attach overnight. The cells were then exposed to test compounds and grown in a continuous cell culturing platform with integrated optics (Cell-IQ®) in a humidified 5%-CO₂ atmosphere at 37 °C for 72 h. Phase contrast microscopic images were captured automatically from 3–4 positions per well at 1 h intervals. Protocols for analysing cell numbers and cell morphology with Cell-IQ Analyzer® software were created according to manufacturer's instructions separately for both cell lines. First, segmentation parameters (maximum cell diameter, distance between cells, cell symmetry, and segmentation gradient threshold representing the sensitivity of the system for intensity changes in cell structures) were adjusted to achieve optimal cell recognition. Then a sample library of different cell morphologies was created and based on that the software learned to classify recognized cells into dead, dividing, and healthy cells. In addition, a class was added for false recognitions of background, and for HeLa cell analysis, a class for elongated cells was included. For SH-SY5Y cell analysis neurite finder was included in the protocol. The protocols were optimized several times by analysing a set of sample images and by thereafter changing the analysis parameters or adding classification samples according to the results. The protocols were also tested for accuracy by comparing classifications from a set of sample images to classifications made visually by three researchers. Finally, images captured during the experiments were analysed with the protocol. An example of HeLa cell classification is provided in Figure 8.

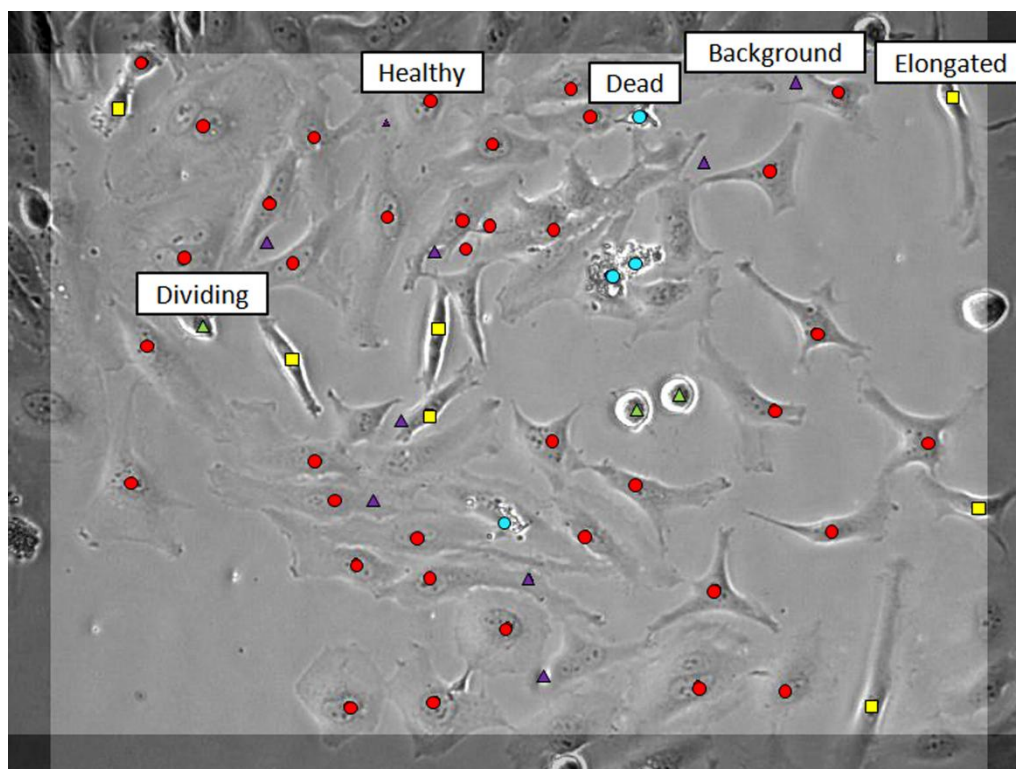

Figure 8. Classification of HeLa cells with Cell-IQ®. Cells classified as normal, “healthy”, are marked with red circles, dividing with green triangles, dead with blue circles, and elongated with yellow squares. Recognitions classified as background are marked with lilac triangles.

4.6 Western blotting

4.6.1 Sample preparation (I-IV)

For immunoblotting experiments, 85–95% confluent 6-well plates of HeLa or SH-SY5Y cells were exposed to test compounds and homogenised. For the preparation of whole-cell homogenates, cells were lysed with 1% sodium dodecyl sulphate (SDS) in 10 mM Tris-HCl (pH 7.5), genomic DNA was sheared with a 25 gauge needle, lysates were centrifuged (16 000 *g*, 15 min, 4 °C) and protein concentrations were determined from the supernatants with bicinchoninic acid assay (Pierce BCA Protein Assay Kit, Thermo Scientific). For extracting the soluble fractions, the cells were harvested in ice-cold lysis buffer containing 20 mM Tris-HCl (pH 7.4), 0.1% Triton X-100, 2 mM EDTA, 10 mM EGTA, and protease inhibitors (Complete Protease Inhibitor Cocktail, Roche). If phosphoproteins were studied, phosphatase inhibitors (PhosSTOP Phosphatase Inhibitor Cocktail Tablets, Roche) were added to the buffer prior to use. After a 30-min incubation on ice, the lysates were centrifuged (16 000 *g*, 15 min, 4 °C) and the protein concentrations of the supernatants were determined using Bradford’s method (Bradford, 1976).

4.6.2 Protein separation and detection (I-IV)

Equal amounts of protein were loaded onto SDS-polyacrylamide (SDS-PAGE) gels and separated under constant voltage. Proteins were then transferred onto Protran® nitrocellulose membranes

(Schleicher & Schuell, Dassel, Germany) and non-specific binding was blocked with 5% powdered non-fat milk or bovine serum albumin (BSA) in Tris-buffered saline containing 0.1% Tween 20 (TTBS) at RT. The membranes were then incubated with primary antibody (see Table 2) overnight at 4 °C and thereafter with horseradish peroxidase (HRP)-conjugated secondary antibody (see Table 2) for 1 h at RT. Immunoreactive bands were detected with enhanced chemiluminescence (ECL; SuperSignal West Pico Chemiluminescent Substrate Kit, Thermo Scientific) using GeneGnome imaging system (Syngene, Cambridge, UK). Relative densities were quantified using Scion Image or ImageJ software.

Table 2. Antibodies used in studies I–IV.

Primary antibodies, species	Dilution in ICH	Dilution in WB	Blocking in WB	Producer, product no.
β actin, r		1:1000	milk	CST, #4967
cofilin-1, r	1:50	1:1000	BSA	(Hotulainen et al., 2005)
cyclin A, m		1:2000	milk	CST, #4656
cyclin B1, m		1:2000	milk	CST, #4135
cyclin D1, m		1:2000	milk	CST, #2926
cyclin E, m		1:1000	milk	CST, #4129
ERK1, r		1:1000	milk	SCBT, sc-94
GAPDH, m		1:2500	milk	SCBT, sc-47724
p21 ^{waf1/cip1} , m		1:2000	milk	CST, #2946
p27 ^{kip1} , m		1:1000	milk	CST, #3698
phospho-Cofilin-1 (Ser3), r	1:50	1:1000	BSA	CST, #3313
phospho-ERK1/2 (Thr202/Tyr204), r		1:1000	BSA	CST, #9101
phospho-Rb (Ser795), m		1:1000	milk	CST, #9301
PKCα, m		1:1000	milk	SCBT, sc-8393
PKCβ, m		1:1000	milk	SCBT, sc-8049
PKCδ, r		1:1000	milk	SCBT, sc-213
Rb, m		1:2000	milk	CST, #9309
vinculin, m	1:100			Sigma-Aldrich, V9131
Secondary antibodies	Dilution in ICH	Dilution in WB	Blocking in WB	Producer, product no.
Alexa Fluor®488 goat anti-mouse	1:200			Invitrogen, A-11001
Alexa Fluor®594 goat anti-mouse	1:200			Invitrogen, A-21125
Alexa Fluor®488 goat anti-rabbit	1:200			Invitrogen, A-11034
Alexa Fluor®647 goat anti-rabbit	1:200			Invitrogen, A-21245
HRP-linked horse anti-mouse		1:2000	milk	CST, #7076
HRP-linked goat anti-rabbit		1:2000	milk/BSA	CST, #7074

BSA, bovine serum albumin; CST, Cell Signaling Technology (Danvers, MA, USA); GAPDH, glyceraldehyde 3-phosphate dehydrogenase; ICH, immunocytochemistry; m, mouse; r, rabbit; Rb, retinoblastoma; SCBT, Santa Cruz Biotechnology (Santa Cruz, CA, USA); WB, Western blotting.

4.7 Immunocytochemistry and fluorescence microscopy (III)

HeLa cells were seeded onto 13 mm cover slips in 35 mm culture dishes, grown overnight and exposed to test compounds. After drug exposure, the coverslips were washed with PBS and fixed with 4% paraformaldehyde for 20 min at RT. Coverslips were then washed 2 times with Dulbecco's phosphate buffered saline containing 0.2% BSA (DB) and the cells were permeabilized with 0.1% Triton X-100 for 7 min. Cells were then washed, incubated with primary antibodies (see Table 2) in DB for 60 min at RT, washed again and incubated with secondary antibodies (see Table 2), phalloidin (Alexa Fluor® 488 phalloidin or Alexa Fluor® 568 phalloidin; Invitrogen) and/or 4',6-diamidino-2-phenylindole (DAPI; Sigma-Aldrich) in DB for 45 min at RT. After washing, the coverslips were

mounted onto Mowiol® (Sigma-Aldrich) containing 1,4-diazabicyclo[2.2.2]octane (DABCO; Sigma-Aldrich). Cells were imaged with a charge-coupled device camera (AxioCam HRm; Carl Zeiss Microscopy GmbH, Jena, Germany) on Axio Imager.M2 microscope (Zeiss) using PlanApo 63x/1.40 (oil) objective (Zeiss) and AxioVision Rel. 4.8 software (Zeiss).

4.8 Genome-wide gene expression analysis (III, IV)

HeLa and SH-SY5Y cells were grown to 80–90% confluence on 6-well plates and exposed to test compounds or DMSO for 12 h. The cells were then washed with PBS, detached with Trypsin-EDTA, washed again with PBS, snap-frozen in liquid nitrogen and stored at -70 °C. RNA extraction, RNA purification and genome-wide gene expression analysis were performed in the Biomedicum Functional Genomics Unit, University of Helsinki (Helsinki, Finland). Briefly, RNA was extracted and purified with RNeasy kit (Qiagen, Hilden, Germany). Total RNA was amplified and labelled with Illumina® TotalPrep RNA Labeling Kit (Life Technologies Ltd, Paisley, UK). Purified biotinylated cRNA was hybridized to HumanHT-12 v4 Expression BeadChips (Illumina®, Life Technologies) for 18 hours at 58 °C. BeadChips were then washed, blocked and stained with streptavidin-Cy3 and scanned with Illumina® iScan. The data was exported using Illumina® BeadStudio and further processed and analyzed with R/bioconductor, BeadStudio, RankProd and biomaRt. Microarray quality was evaluated using hierarchical clustering, principal component analysis and control probe analysis. The relative reliability of each array was assessed using the arrayWeights function of Limma. Gene expression levels between sample sets were compared using moderated paired t-test (package IBMT, $p < 0.05$) with a Benjamini-Hochberg multiple test correction to minimize selection of false positives. Gene set enrichment analysis (GSEA) was performed using GOrilla (<http://cbl-gorilla.cs.technion.ac.il>) (Eden et al., 2009).

4.9 Statistical analysis (I-IV)

All statistical analyses were carried out with SPSS 16 or PASW statistics 18 software (SPSS Inc., Chicago, IL, USA). Statistical analysis for dose-response data from [³H]PDBu binding assays (I), and cell viability and proliferation assays (II, III) as well as for immunoblotting quantification data (I - IV) was performed using one-way analysis of variance (ANOVA) followed by Tukey's honestly significant difference (HSD) post hoc test. Dunnett's multiple comparison test was used to analyse GAP-43 quantifications (IV), and PKC α protein levels after cellular fractionation (IV) was analysed with Student's *t*-test. Comparison of time-response curves from Cell-IQ® (in IV) was performed with repeated measures ANOVA followed by Tukey's HSD.

5. RESULTS

5.1 Structure-activity relationship studies on isophthalate derivatives (I, III)

A starting point for the design of C1 domain ligands was the commercially available diethyl (5-hydroxymethyl)isophthalate (HMI-1b21, Fig. 7), a hit molecule from a virtual screening campaign of commercially available small molecules using the crystal structure of the PKC δ C1b domain (Zhang et al., 1995). Its structure complied with the pharmacophore model created based on phorbol (Wang et al., 1994), and it provided an easily modifiable template for the synthesis of various derivatives. Preliminary binding studies demonstrated that while HMI-1b21 did not bind to the PKC C1 domain, dipentyl (5-hydroxymethyl)isophthalate displaced [3 H]PDBu from PKC (unpublished). These studies aimed to find out, which functional groups are needed and how different substituents affect binding. Furthermore, these experiments aimed at providing evidence of isophthalate binding to the PKC C1 domain in cellular context.

5.1.1 Binding to the C1 domain of PKC (I)

For studying structure-activity relationships (SAR) of the template, 42 first-generation isophthalic acid derivatives were assayed for binding to C1 domains of recombinant full-length human PKC α and PKC δ produced in Sf9 cells. A schematic presentation of the SAR studies is provided in Figure 9 (for numerical data and results of individual compounds, see Tables 1 and 2 in I). The SAR studies revealed that the 5-hydroxymethyl group and the ester groups of the template are indispensable. Additionally, sufficient hydrophobicity of the side chains is required: The dialkyl (5-hydroxymethyl)isophthalates that displaced [3 H]PDBu from PKC α and PKC δ in a concentration-dependent manner with low micromolar concentrations had clogP values of 5.0 or higher.

5.1.2 Binding affinity constants for PKC α and PKC δ (I)

Three isophthalate derivatives (HMI-1a3, HMI-1b10 and HMI-1b11) were selected for more detailed analysis of binding affinity. First the K_d of the radioligand [3 H]PDBu was determined for both PKC α and PKC δ (1.29 nM and 2.35 nM, respectively), and the validity and accuracy of the assay was confirmed by determining the K_i values of DOG for PKC α (40.1 ± 6.0 nM, $n=4$) and of bryostatin 1 for PKC δ (0.44 ± 0.08 nM, $n=5$). These values are in accordance with published data (Wender et al., 1998; Ananthanarayanan et al., 2003).

The isophthalate derivatives displaced [3 H]PDBu from PKC α and PKC δ with K_i values in the range of 205–915 nM (Fig. 10). No significant differences in affinities (potencies) between the ligands were detected. However, differences in the magnitude of maximal [3 H]PDBu displacement were observed. HMI-1a3 was the least effective isophthalate: It only displaced 55% and 37% of [3 H]PDBu from PKC α and PKC δ , respectively (Fig. 10). In comparison, HMI-1b10 was the most effective derivative displacing 84% and 88% of [3 H]PDBu from PKC α and PKC δ , respectively (Fig. 10). While HMI-1a3 was more effective in displacing [3 H]PDBu from PKC α than from PKC δ , no difference in maximal [3 H]PDBu displacement for the two PKC isoforms were observed with HMI-1b10 and HMI-1b11 (Fig. 10).

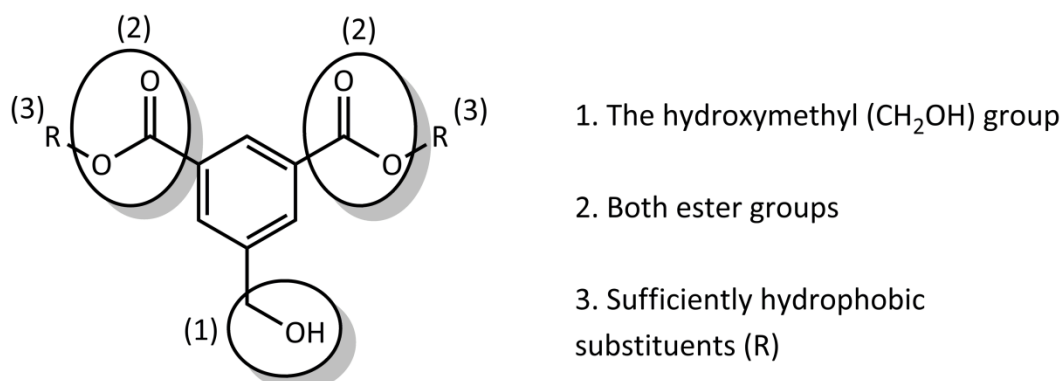
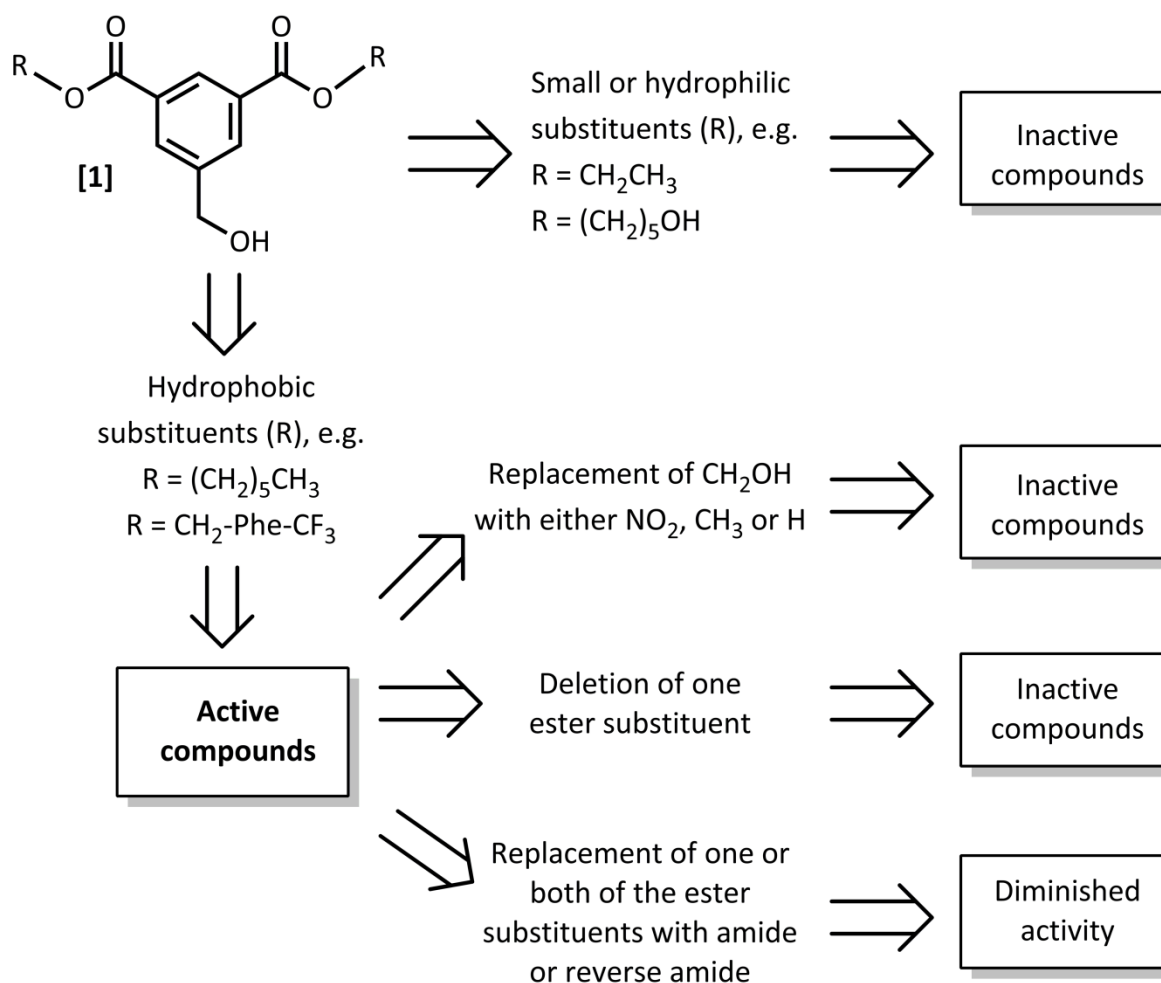

Figure 9. Schematic presentation of the structure activity relationship (SAR) studies with the isophthalate template [1]. Compounds with low micromolar binding affinity are designated as active compounds and those with no affinity for the C1 domain as inactive compounds. The lower panel presents the structural elements required for binding.

5.1.3 Binding to other DAG effectors (III)

To confirm the SAR model created based on the binding experiments with PKC, binding of 15 active and 4 inactive isophthalate derivatives to recombinant full-length $\beta 2$ -chimaerin from Sf9 cell lysates was studied. The results followed the SAR model generated based on binding experiments with PKC.

The active isophthalates displaced [^3H]PDBu from $\beta 2$ -chimaerin in a concentration-dependent manner with submicromolar and low micromolar concentrations, and the inactive derivatives had no affinity for the C1 domain of $\beta 2$ -chimaerin (not shown, unpublished). As an example, HMI-1a3 displaced [^3H]PDBu from $\beta 2$ -chimaerin with an IC_{50} of 1.2 μM (Table 3, Fig. 6 in III). To further characterize the binding properties of HMI-1a3, its affinity to the C1 domains of PKD and MRCK was studied. HMI-1a3 displaced [^3H]PDBu from PKD1 in a concentration-dependent manner in a similar concentration range as with PKCs (Table 3, Fig. 6 in III), while NI-15e exhibited no binding at concentrations up to 100 μM (not shown, unpublished). Furthermore, HMI-1a3 bound to the C1 domain of MRCK α produced in *E. coli* in a similar low micromolar concentration range (Table 3, Fig. 6 in III).

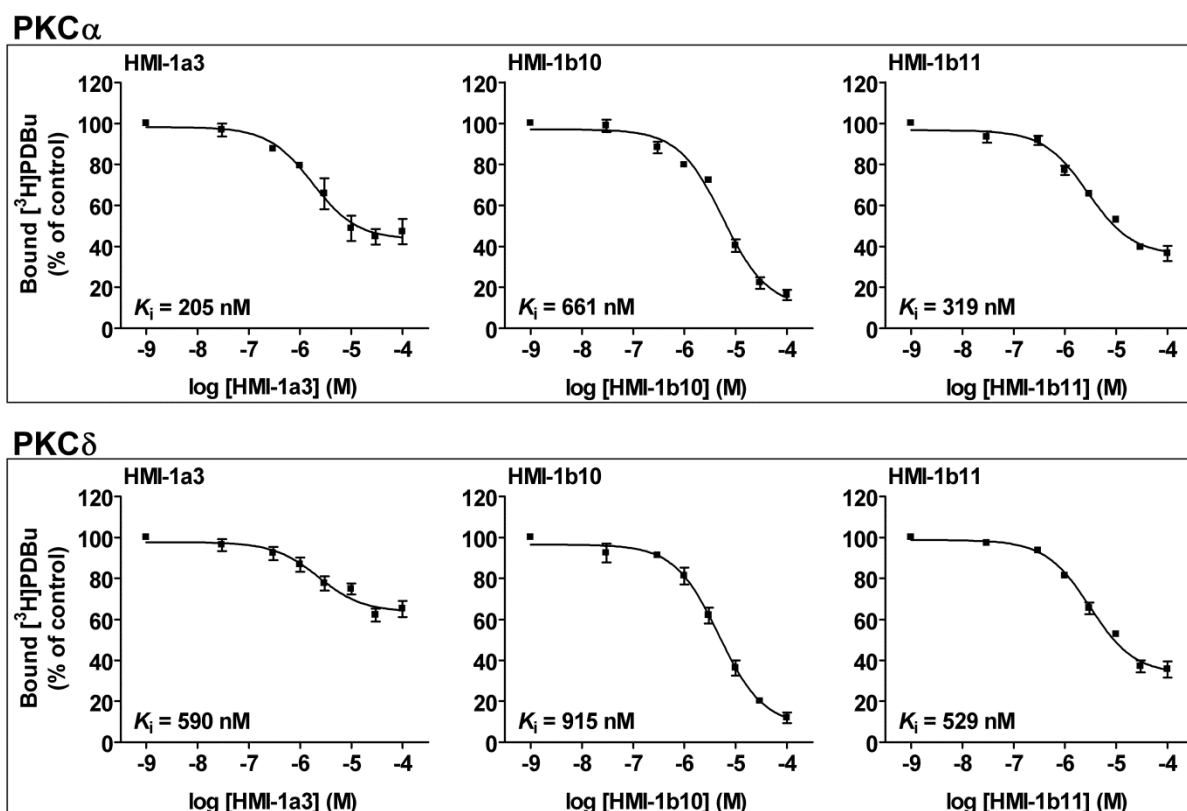

Figure 10. Binding of HMI-1a3, HMI-1b10 and HMI-1b11 to purified PKC α and PKC δ . Displacement of 10 nM [^3H]PDBu was measured with the centrifugation method in the presence of graded concentrations of isophthalates. The data was analysed with GraphPad Prism 4 using a one-site competition equation. Results are presented as mean \pm SEM from 3–5 independent experiments.

5.1.4 Effects on ERK1/2 signalling in HeLa cells (I)

To investigate whether the isophthalates regulate PKC-mediated signalling in cellular context, we studied their effects on ERK1/2 phosphorylation in HeLa cells. When added to cell culture medium, HMI-1a3 and HMI-1b10 induced PKC-dependent ERK1/2 phosphorylation, but HMI-1b11 alone had no effect (Fig. 4 in I). Instead, HMI-1b11 inhibited PMA-induced ERK1/2 phosphorylation in a concentration-dependent manner showing that it does bind to the PKC C1 domain in cellular context as well (Fig. 4 in I).

Table 3. Binding affinity of HMI-1a3 to the C1 domains of β 2-chimaerin, PKD and MRCK α . The IC_{50} value for PKC α is provided for comparison.

DAG effector	IC_{50} (μ M)	Receptor protein	Purification	Method
β 2-chimaerin	1.2	recombinant full length β 2-chimaerin	crude Sf9 cell lysate (not purified)	filtration
PKD1	6.3	recombinant 6His-tagged full length PKD1 (#14-508, Millipore)	commercially purified (72% pure)	centrifugation
MRCK α	1.3	recombinant GST-tagged C1 domain of MRCK α	affinity purified (\approx 80% pure)	filtration
PKC α	1.8	recombinant full length PKC α (P2232, Invitrogen)	commercially purified (95% pure)	centrifugation

The data was analysed with GraphPad Prism 4 with one-site competition equation using mean and SEM values from 3-4 independent experiments.

5.2 Effects of isophthalate derivatives in HeLa cells (II, III)

5.2.1 Viability and proliferation (II)

Effects of five active and four inactive isophthalate derivatives on HeLa cell viability were studied using MTT and LDH tests after 24 and 48-hour exposures. None of the isophthalates induced necrosis as indicated by <10% cytotoxicity in the LDH assay (not shown). However, several of the active compounds induced a decrease in mitochondrial reduction capacity according to the MTT assay (Fig. 2 in II). HMI-1a3 was the most potent compound inhibiting the metabolic activity of HeLa cells with an IC_{50} of 0.3 μ M ($p < 0.001$) (Fig. 2 in II). HMI-1b10 and HMI-1b11, on the other hand, had only a slight effect at 20 μ M, the highest concentration tested (Fig. 2 in II), and the inactive isophthalate derivatives had no effect (Fig. 2 in II). PMA (at concentrations 0.1 nM - 1 μ M) inhibited MTT reduction only at 10 nM ($p < 0.01$), but exhibited no cytotoxicity according to the LDH test (Fig. 2 in II). Bryostatin 1 had no influence on HeLa cell viability at concentrations 0.1-100 nM (Fig. 2 in II).

According to Cell-IQ[®] analysis isophthalate derivatives with low micromolar binding affinity to PKC exhibited a concentration-dependent antiproliferative effect. HMI-1a3 was the most potent derivative: It inhibited proliferation with an IC_{50} of 2.0 μ M (Fig. 11A). The inactive isophthalates had no effect (NI-15e shown in Fig. 11A, Fig. 4 in II). PMA (at 1-1000 nM) had no significant effect on proliferation (Fig. 4 in II).

Effects of HMI-1a3 were further characterized by studying its effects on DNA synthesis. HMI-1a3 inhibited thymidine incorporation in a concentration-dependent manner after 6-hour and 24-hour exposures (IC_{50} values 5.8 μ M and 4.5 μ M, respectively) (Fig. 3 in II). Furthermore, to investigate the influence of HMI-1a3 on cell cycle progression, its effects on various cell cycle markers was studied with Western blotting. A 24-hour exposure to 10 μ M or 20 μ M HMI-1a3 induced down-regulation of cyclins A, B1, D1 and E, and total and phosphorylated retinoblastoma protein (II, not shown). At 10 μ M (but not at 20 μ M) HMI-1a3 also down-regulated p21^{waf1/cip1} and p27^{kip1} proteins (Fig. 7 in II). In contrast, PMA and bryostatin 1 (both at 100 nM) induced prominent up-regulation of cyclin D1 and p21^{waf1/cip1}, and down-regulation of 27^{kip1} (Fig. 7 in II).

5.2.2 Morphology and cytoskeleton (II, III)

The antiproliferative isophthalate derivatives, including HMI-1a3, induced a morphological change that was characterized by cell elongation and reduced cell-to-cell contacts (Fig. 11D–F). A more detailed analysis revealed that after exposure to active isophthalates at antiproliferative concentrations the proportion of apparently healthy cells decreased and the proportion of elongated cells increased rapidly, followed by a delayed increase in the proportion of dead cells (HMI-1a3 shown in Fig. 11C). In contrast, the morphology of untreated cells and cells exposed to vehicle (DMSO) or inactive isophthalates remained unchanged (untreated cells shown in Fig. 11B). PMA induced a transient cell elongation followed by a more rounded cell morphology (Fig. 6 in II).

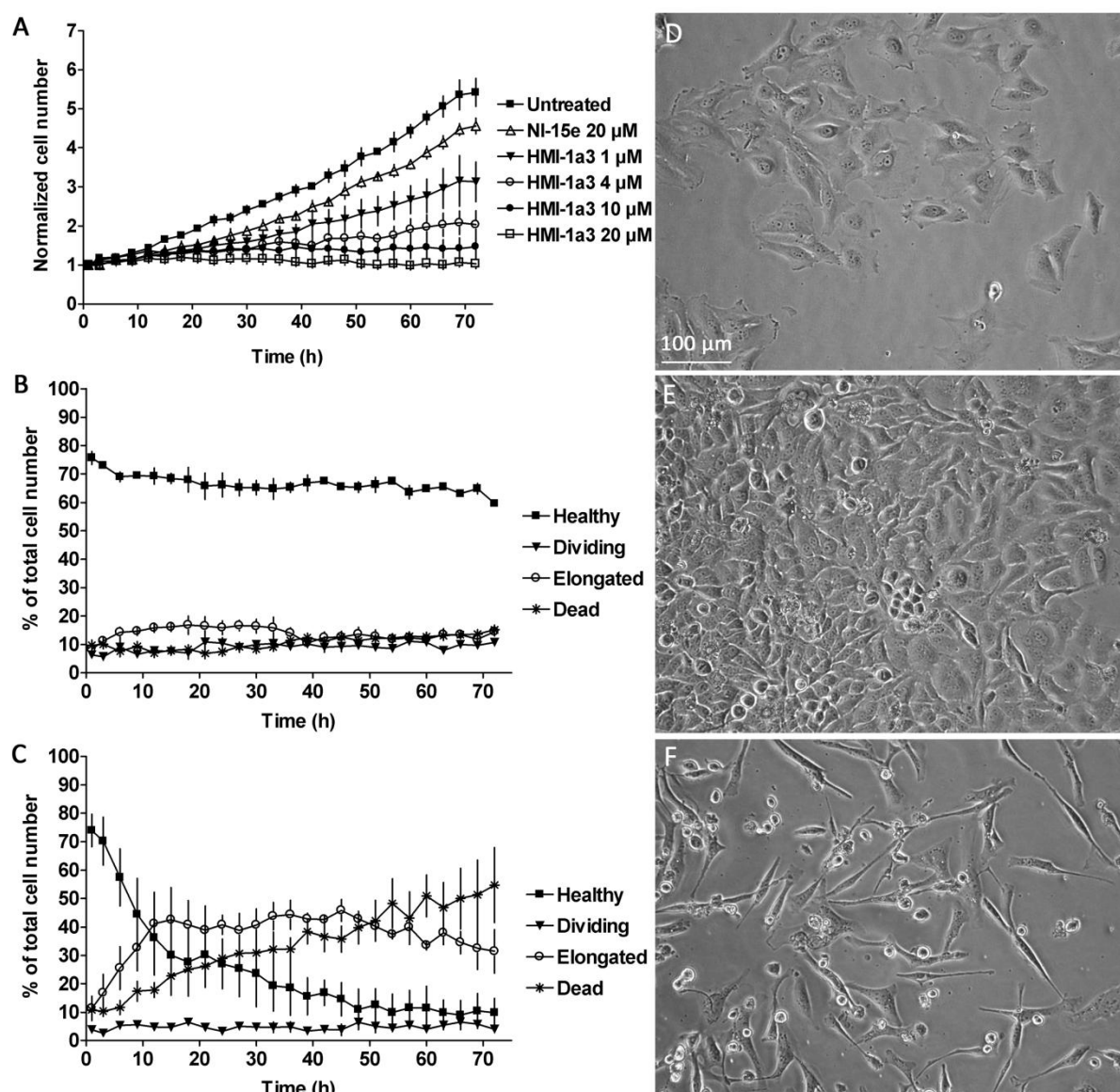

Figure 11. Effects of HMI-1a3 on HeLa cell proliferation and morphology. HeLa cells were exposed to test compounds, imaged with Cell-IQ[®] and analysed with Cell-IQ Analyzer[®] software. Quantifications from images captured with 3-hour intervals are presented in A–C (mean \pm SEM, $n=3$). A, normalized total cell numbers of untreated cells and cells exposed to HMI-1a3 or NI-15e; B, classification results of untreated cells; C, classification results of cells exposed to 20 μ M HMI-1a3. D–F, representative photomicrographs of untreated cells at time points 1 h (D) and 72 h (E), and of cells exposed to 20 μ M HMI-1a3 for 72 h (F).

The effects of HMI-1a3 and NI-15e on cytoskeleton were studied further using immunocytochemistry. Filamentous actin (F-actin) forms microfilaments that are a central part of the cytoskeleton and regulate cell shape and motility. The effects of HMI-1a3 and NI-15e on actin cytoskeleton were visualized using phalloidin, a toxin that binds to F-actin. Focal adhesions are protein complexes that connect the cytoskeleton to the extracellular matrix. They were visualized by staining one of their important constituents, vinculin. HMI-1a3-induced cell elongation was accompanied with loss of focal adhesions and actin stress fibres (Fig. 12), while exposure to NI-15e had no effect (not shown).

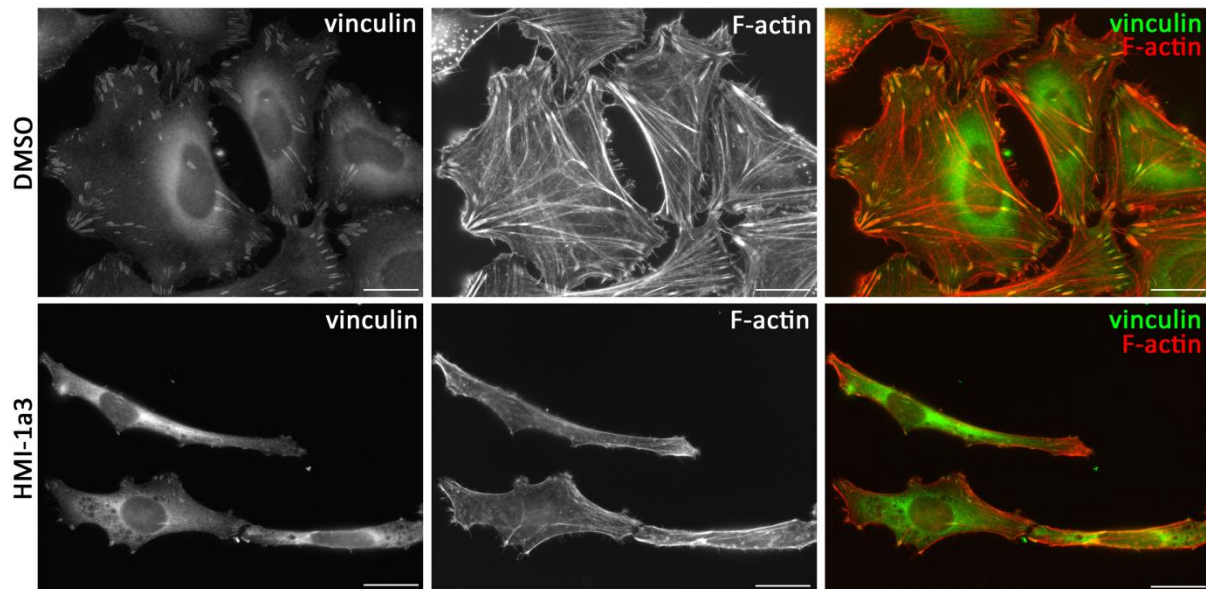

Figure 12. Effects of HMI-1a3 on HeLa cell cytoskeleton. HeLa cells were exposed to 0.2% DMSO or 20 μ M HMI-1a3 for 24, fixed and stained. Focal adhesions were visualized using an antibody against vinculin and stress fibres (F-actin) were detected with phalloidin. Representative epifluorescence microscopic images are presented ($n=2$ for focal adhesions, $n=8$ for F-actin). Scale bar, 20 μ m.

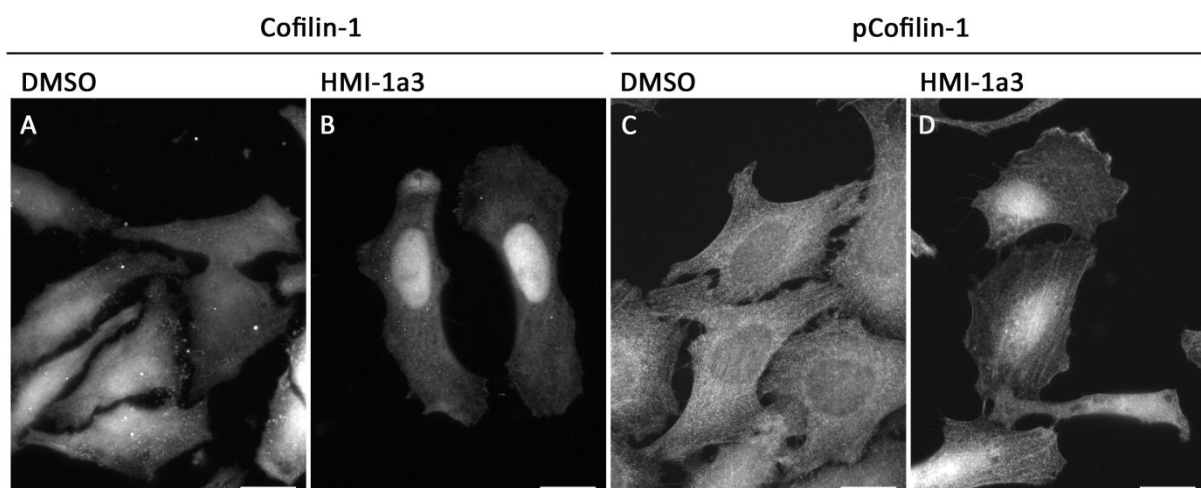

Figure 13. Effect of HMI-1a3 on the localization of cofilin-1 and phosphorylated cofilin-1 (pCofilin-1). HeLa cells were exposed to 0.1% DMSO or 10 μ M HMI-1a3 for 24 h, fixed and stained with antibodies recognizing either total cofilin-1 (A, B) or phosphorylated cofilin-1 (C, D). Representative epifluorescence microscopic images are presented ($n=3$). Scale bar, 20 μ m.

The prominent changes in actin cytoskeleton lead us to investigate the effects of HMI-1a3 on the phosphorylation status and intracellular localization of the actin-depolymerizing protein cofilin-1, which is the cofilin isoform present in non-muscle cells (Bernstein and Bamburg, 2010). In untreated cells or in cells treated with 0.2% DMSO or 20 μM NI-15e cofilin-1 was localized either in the cytosol or diffusely in both cytosol and nucleus (DMSO shown in Fig. 13A, Fig. 3 and 4A in **III**). A 24-hour exposure to 10 μM or 20 μM HMI-1a3 induced a clear relocation of cofilin-1 regardless of cell morphology: Cofilin-1 was predominantly localized in the nucleus of both elongated and normal-looking cells (10 μM HMI-1a3 shown in Fig. 13B, Fig. 3 and 4A in **III**). A similar pattern of localization was observed for phosphorylated cofilin-1 (Fig. 13C–D, unpublished). However, HMI-1a3 had no effect on the phosphorylation state of cofilin-1 as determined by Western blotting (Fig. 4B in **III**).

5.2.3 Mechanistic studies on isophthalate-induced effects in HeLa cells (II, III)

Genome-wide gene expression microarray and subsequent GSEA (Subramanian et al., 2005) were carried out to identify signalling pathways that may be responsible for mediating the effects of isophthalates in HeLa cells. Numerical comparison of genes, whose expression was statistically significantly different between the treatments, is presented in Table 4. A 12-h exposure to HMI-1a3 induced changes in a remarkably greater number of genes than HMI-1b11 or NI-15e. Based on GSEA, the biological processes that were most significantly altered in HMI-1a3-exposed cells were related to cell cycle and proliferation as well as cell motility, migration and cytoskeleton reorganization (Table 1 in **III**), consistent with the antiproliferative and elongation-inducing effects of HMI-1a3. Other biological processes significantly altered in HMI-1a3-exposed cells compared to NI-15e-exposed cells included for example RNA processing, cholesterol biosynthesis and small GTPase-mediated signal transduction (Table 1 in **III**).

Since the cell viability assays pointed to a non-necrotic mechanism of cell death, the effect of caspase inhibition on HeLa cell response to HMI-1a3 was examined. The pan-caspase inhibitor BAF (at 40 μM) had no effect on HMI-1a3-induced changes in HeLa cell proliferation and viability when assessed with Cell-IQ[®] imaging (Table 5, Fig. 5 in **II**).

Table 4. Differential regulation of gene expression by isophthalate derivatives in HeLa cells. The table presents the numbers of genes whose mRNA level were statistically significantly different between the indicated treatments (12 h).

	DMSO (0.1%)	NI-15e (10 μM)	HMI-1b11 (10 μM)
HMI-1a3 (10 μM)	1411	1277	1396
HMI-1b11 (10 μM)	304	85	-
NI-15e (10 μM)	9	-	-

To clarify the signalling pathways responsible for mediating the antiproliferative and elongation-inducing effects of HMI-1a3, the involvement of PKC and ERK1/2 signalling pathways was first investigated. Co-exposure to the pan-PKC inhibitor Gö6986 (1 μM) or the PKC activator PMA (at 10 or 100 nM) did not modify the cytotoxic and antiproliferative effect of HMI-1a3 as determined by MTT assay (Table 5, Fig. 5 in **III**). Gö6983 alone had no effect on HeLa cell proliferation and it did not modify the effects of HMI-1a3 on cell proliferation, morphology or viability as assessed by Cell-IQ[®] imaging (Table 5, Fig. 5 in **III**). Furthermore, knock-down of PKC α or PKC δ with RNAi did not influence

the antiproliferative effect of HMI-1a3 (Table 5, Fig. 5 in III). The MEK inhibitor U0126 (10 μ M) was unable to inhibit HMI-1a3-induced responses as determined by the MTT assay or Cell-IQ[®] analysis (Table 5, Fig. 5 in III).

Based on results from gene expression microarray and GSEA indicating changes in processes linked to small GTPase-mediated signalling, PKD and MRCK were considered potential mediators of isophthalate-induced effects in HeLa cells. To investigate their role in mediating HMI-1a3-induced changes in cell morphology and proliferation, effects of the PKD inhibitor CID755673 and the MRCK inhibitor chelerythrine on HeLa cell response to HMI-1a3 were studied with Cell-IQ[®] imaging. CID755673 (at 1 μ M or 10 μ M) had no effect on HeLa cell proliferation or morphology, or on HMI-1a3-induced responses (Table 5, Fig. 7 in III). The MRCK inhibitor chelerythrine was toxic to HeLa cells: concentrations of 4 μ M and 10 μ M induced rapid cell death and prevented analysis with these concentrations (not shown). However, at the lower concentrations of 1 μ M and 2 μ M chelerythrine inhibited HMI-1a3-induced cell elongation: The inhibition was most prominent (38% and 42%, respectively) at the time point 24 h (table ZX, Fig. 7 in III). No significant differences were observed in the proportions of healthy, dividing or dead cells (Fig. 7 in III).

Table 5. Summary of mechanistic studies on HMI-1a3-induced effects in HeLa cells. Effects of modulation of PKC, PKD, MRCK, or ERK1/2 signalling pathways or inhibition of caspases on HMI-1a3-induced changes in HeLa cell proliferation, viability and morphology.

Target	Treatment	Response			
		Inhibition of proliferation	Cell elongation	% of dead cells	Cytotoxicity (MTT)
PKC	Co-exposure to HMI-1a3 (at 0.1-20 μ M) and Gö6983 1 μ M	–	–	–	–
	PMA 10 nM, 100 nM	–	–	–	–
	PKC α siRNA	–	–	–	n/a
	PKC δ siRNA	–	–	–	n/a
PKD	CID-755673 1 μ M, 10 μ M	–	–	–	n/a
MRCK	Chelerythrine 1 μ M, 2 μ M	–	↓	–	n/a
MEK	U0126 10 μ M	–	–	–	–
caspases	BAF 40 μ M	–	–	–	n/a

–, no effect on HMI-1a3-induced response; ↓, inhibition of HMI-1a3-induced response ($p < 0.05$); n/a, not analysed

5.3 Effects of isophthalate derivatives in SH-SY5Y cells (IV)

The human neuroblastoma cell line SH-SY5Y, which is widely used as an *in vitro* model of neuronal function and differentiation (Påhlman et al., 1990; Agholme et al., 2010), was used to characterize the effects of two active isophthalates (HMI-1a3 and HMI-1b11) and their corresponding inactive derivatives (NI-15e and MI-40, respectively) on neuronal-like cells. The active isophthalates HMI-1a3 and HMI-1b11 were selected based on their divergent effects on ERK1/2 phosphorylation in HeLa cells and on HeLa cell viability and proliferation.

5.3.1 Cell proliferation, viability and morphology (IV)

Both HMI-1a3 and HMI-1b11 inhibited SH-SY5Y cell proliferation in a concentration-dependent manner, whereas MI-40 had no effect (Fig. 14A). At the end of the experiment, inhibition of proliferation was statistically significant with 20 μ M HMI-1a3 ($p < 0.01$) and with 10–20 μ M HMI-1b11 ($p < 0.05$). PMA was antiproliferative only at 10 nM (30% inhibition of proliferation), but not with other concentrations studied (0.1, 1, 100 and 1000 nM) (not shown and Fig. 3 in IV). HMI-1a3 induced toxicity at the highest concentration tested (20 μ M; 31% of cells were dead at 48 h), while HMI-1b11, MI-40 or PMA had no effect on cell viability (not shown, IV).

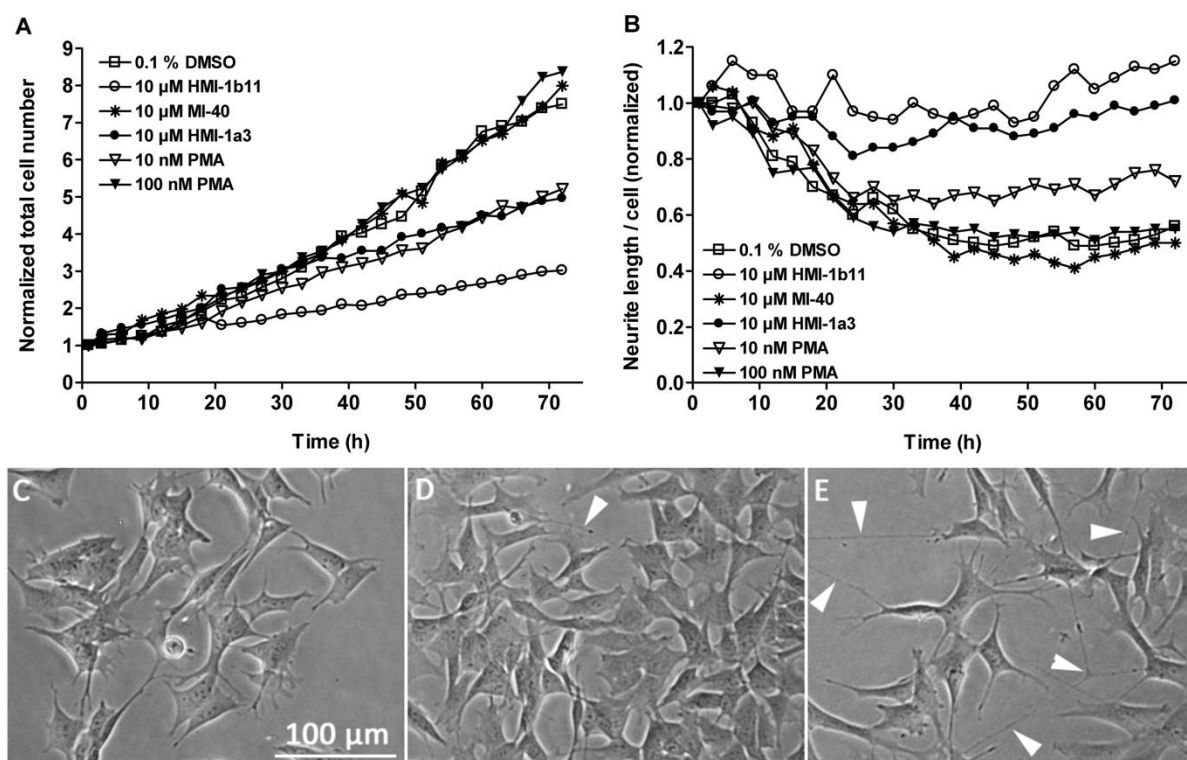

Figure 14. Effects of isophthalate derivatives on SH-SY5Y cell proliferation and morphology. Cells were exposed to vehicle (DMSO) or test compounds as indicated and imaged for 72 h with Cell-IQ[®]. Cell numbers and neurite lengths were analysed from each image using Cell-IQ Analyzer[®]. Quantifications of images taken at 3 hour intervals are shown as mean of 3 independent experiments (each with 4 images from different positions within the same well). A, quantification of SH-SY5Y cell proliferation; B, quantification of average neurite length; C, a representative photomicrograph of untreated cells (t=1 h); D, a representative photomicrograph of cells exposed to 0.1% DMSO (t=70 h); E, a representative photomicrograph of cells exposed to 10 μ M HMI-1b11 (t=70 h). Arrowheads indicate examples of neurites.

Based on visual observation, SH-SY5Y cells exposed to HMI-1a3 or HMI-1b11 exhibited more pronounced (longer and also branched) neurites when compared with untreated cells or cells exposed to DMSO, MI-40 or PMA (Fig. 14C–E and not shown). Quantification showed that the average neurite length of untreated cells or cells exposed to DMSO, MI-40 or PMA decreased during the first 30–40 hours of the experiment and thereafter remained constant (Fig. 14B, Fig. 3 in IV). HMI-1a3 and HMI-1b11 inhibited the decrease in neurite length in a concentration-dependent manner (Fig. 14B, Fig. 3 in IV). There was a statistically significant time-dependent change in neurite length ($p < 0.001$, repeated measures ANOVA) and a time and treatment interaction ($p < 0.05$), but no statistical significance for a treatment-dependent effect in post-hoc tests.

5.3.2 Genome-wide gene expression and GSEA (IV)

Because HMI-1b11 was non-toxic and supported neurite outgrowth, it was selected for gene expression microarray studies. A 12-hour exposure to 10 μ M HMI-1b11 induced statistically significant changes in the expression of 1071 genes when compared with cells exposed to vehicle (not shown). GSEA suggested that the gene expression changes may be linked to nucleic acid and/or RNA processing and vesicle transport (not shown). It also revealed statistically significant enrichments in numerous biological processes linked to cell differentiation, small GTPase-mediated signalling, ERK1/2 cascade and Wnt signalling (Table 2 in IV).

5.3.3 PKC and ERK1/2 signalling and GAP-43 expression (IV)

Since the previous experiments suggested that isophthalates modulate ERK1/2 activation, and since ERK1/2 activation has been linked to differentiation of SH-SY5Y cells (Monaghan et al., 2008), the effects of isophthalates on ERK1/2 phosphorylation in SH-SY5Y cells was investigated. Exposure to either HMI-1a3 or HMI-1b11 at 10 μ M induced a rapid and strong ERK1/2 phosphorylation that was efficiently inhibited by co-exposure to the pan-PKC inhibitor Gö6983 at 1 μ M (Fig. 14A, Fig. 4 in IV). PMA (at 100 nM) also induced ERK1/2 phosphorylation, while 10 μ M NI-15e had no effect (Fig. 15A, Fig. 4 in IV). Since the cellular outcome of ERK1/2 activation may depend on the duration of the signalling, ERK1/2 phosphorylation levels were also studied after a 12-hour exposure. At this later time point, the level of phosphorylated ERK1/2 was increased in cells exposed to 10 μ M HMI-1b11 or 100 nM PMA, but not in cells exposed to 10 μ M HMI-1a3, NI-15e or MI-40 (Fig. 15A). No change in total ERK1/2 protein level was observed with isophthalate exposure times up to 24 h (not shown).

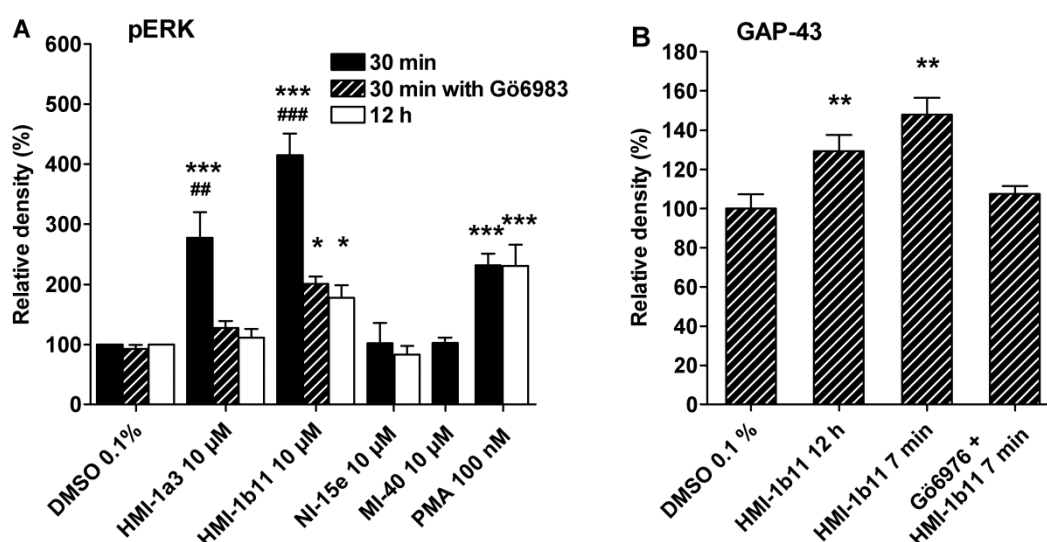

Figure 15. Effects of isophthalates on ERK1/2 phosphorylation and GAP-43 protein level in SH-SY5Y cells. A, Levels of phosphorylated ERK1/2 were determined with Western blotting from soluble fractions of cell homogenates ($n=3-4$; ***, $p<0.001$ vs. DMSO; *, $p<0.05$ vs. DMSO; ###, $p<0.001$ vs. the corresponding Gö6983-treated sample; ##, $p<0.01$ vs. the corresponding Gö6983-treated sample; one-way ANOVA followed by Tukey's HSD). B, SH-SY5Y cells were exposed to 10 μ M HMI-1b11 with or without the cPKC inhibitor Gö6976 (2 μ M) for indicated times, and total cell homogenates were collected 12 hours after the beginning of the exposure. Level of GAP-43 protein was determined with Western blotting ($n=4-6$; **, $p<0.01$ vs. DMSO; Dunnett's multiple comparison test).

The effect of HMI-1b11 on intracellular localization of PKC α on was studied using cell fractionation and immunoblotting. A 7-minute exposure to HMI-1b11 induced an increase of 53% (\pm 13.4%) in PKC α in the cytoskeletal fraction, and an increase of 39% (\pm 14.3%) in total PKC α protein level (Fig. 6 in IV). PKC α levels in soluble or membrane fractions remained unchanged (not shown).

PKC α activation is known to induce activation of nELAV proteins and subsequent RNA stabilization (Pascale et al., 2005). One of the target proteins of nELAVs is GAP-43, a central regulator of neuronal differentiation and plasticity (reviewed in Benowitz and Routtenberg, 1997). Based on the ERK1/2 phosphorylation studies suggesting that HMI-1b11 activates PKC and on GSEA results indicating that RNA processing may be significantly altered in HMI-1b11-treated cells, it was hypothesized that HMI-1b11 exposure could lead to up-regulation of GAP-43. Indeed, exposure to 10 μ M HMI-1b11 induced a clear increase in GAP-43 mRNA (Fig. 5 in IV), consistent with gene expression microarray data showing a 70% increase in GAP-43 mRNA (not shown). GAP-43 protein level was also increased in response to HMI-1b11 exposure, and the effect was diminished by co-exposure to the cPKC selective inhibitor Gö6976 (Fig. 15B, Fig. 5 and 7 in IV).

5.4 Effects of isophthalate derivatives on PKC protein levels (unpublished)

Most C1 domain binding PKC activators are known to induce PKC down-regulation. Since the previous data indicated that the isophthalates activate PKC in both HeLa and SH-SY5Y cells, the protein levels of selected PKC isoforms after 24-hour isophthalate exposures were investigated. In HeLa cells, HMI-1a3 and HMI-1b11 had no effect on the levels of PKC α , PKC β I or PKC δ , while PMA induced a clear down-regulation of PKC α and PKC β I, and a slight down-regulation of PKC δ (Fig. 16A, unpublished). Similarly, exposure to either HMI-1a3 or HMI-1b11 had no significant effect on PKC α , PKC β I or PKC δ protein levels in SH-SY5Y cells. However, in these cells PMA induced a strong down-regulation of PKC isoforms α and δ , but had no effect on the levels of PKC β I (Fig. 16B, unpublished).

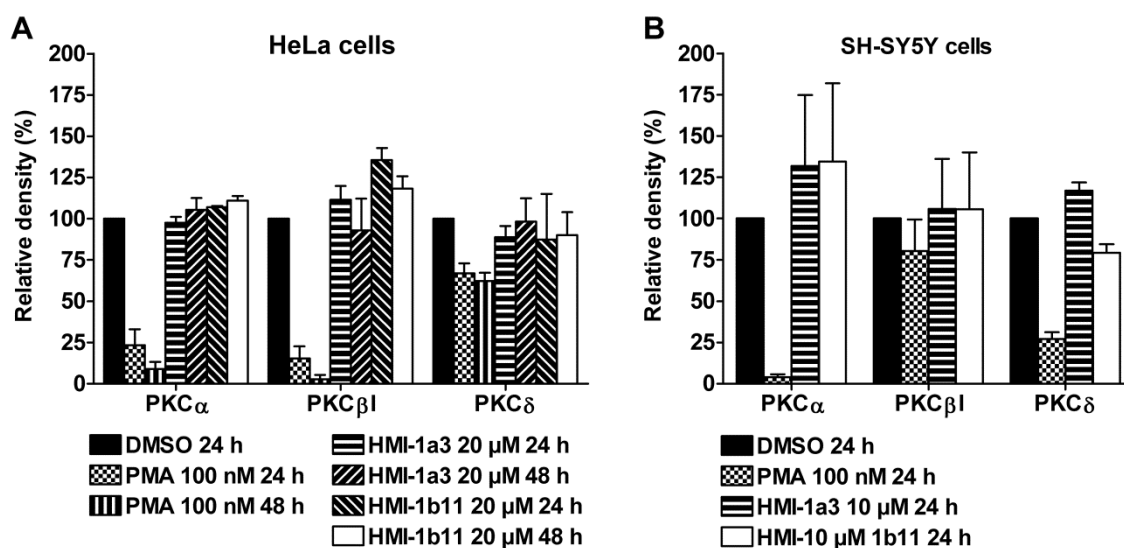

Figure 16. Effects of isophthalates on PKC protein levels in HeLa and SH-SY5Y cells. Cells were exposed to test compounds as indicated and PKC protein levels were analysed from total cell homogenates of (A) HeLa cells and (B) SH-SY5Y cells with Western blotting. Relative densities normalized to densities of β -actin bands are presented as percentage of control (mean + SEM; $n=3-6$, except for HMI-1b11 in HeLa cells, where $n=2$).

6. DISCUSSION

6.1 Structure-activity relationships of isophthalate derivatives

Most of the existing C1 domain ligands are highly complex in their chemical structure and therefore their synthesis and chemical modification in order to achieve selectivity is difficult and laborious (Blumberg et al., 2008; Boije af Gennäs et al., 2011). Therefore, the simple isophthalate template offers an attractive possibility for the development of C1 domain ligands with an easy and effective synthesis route. The indispensable functional groups highlighted in binding experiments were consistent with results from docking experiments and the pharmacophore model. Furthermore, analogous hydroxyl and carbonyl groups are present in other well-characterized C1 domain ligands, such as phorbol esters and DAG lactones (Wang et al., 1994; Benzaria et al., 1998). The contribution of the side chains to binding affinity is difficult to assess in docking experiments, because modelling the interaction between the C1 domain and the lipid bilayer of cell membrane is unfeasible. However, it is known that hydrophobic interactions of the side chains are crucial for high affinity binding and biological effects of phorbol esters, DAG and their analogues (Zhang et al., 1995; Nacro et al., 2000; Wang et al., 2000; Blumberg et al., 2008). The present results showing that a certain level of hydrophobicity of the side chains is essential thus comply with the prevailing understanding of binding requirements. The optimal $\log P$ values for isophthalates (>5.0) are also in line with those reported for DAG lactones (5.0–6.0) (Nacro et al., 2000).

Determination of binding affinity constants (K_i) for the selected isophthalates enables the comparison of isophthalates with other C1 domain ligands. The submicromolar K_i values of isophthalates are 100–1000 fold higher than those of phorbol esters, bryostatins or the best DAG lactones, all of which replace [^3H]PDBu with low nanomolar or subnanomolar affinities (see chapter 2.5 and Boije af Gennäs et al., 2011). The difference to the endogenous ligand DAG was smaller: approximately 10-fold. Modification of the isophthalate structure is thus needed to achieve affinities comparable to the more potent C1 domain ligands.

The finding that HMI-1a3 is somewhat less effective in displacing [^3H]PDBu from PKC δ than from PKC α (although possessing similar potency for both isoforms) may suggest that it has some selectivity for cPKCs over nPKCs. Since no such difference was observed with HMI-1b10 or HMI-1b11, the most probable structural determinant for the difference is the rigidity of the aromatic side chains of HMI-1a3, which are more constrained than the flexible aliphatic side chains of HMI-1b10 and HMI-1b11. The C1 domains of classical and novel PKCs are known to differ in their ligand affinities (Pu et al., 2005; Giorgione et al., 2006; Dries et al., 2007), and the structures of their DAG binding sites may thus differ to a degree that contributes to the observed phenomenon. However, more studies are needed to clarify the mechanism behind the differences in maximal [^3H]PDBu displacement.

Since PKCs are not the only proteins with a C1 domain responsive to phorbol esters and DAG, it was essential to investigate, whether isophthalates bind to other DAG/phorbol ester-responsive C1 domains as well. Based on the high similarity among DAG-responsive C1 domains, the observed binding of isophthalates to the other DAG effectors was expected. Binding studies with $\beta 2$ -chimaerin confirmed the SAR model created with PKC, and binding of HMI-1a3 to PKD and the C1 domain of

MRCK further indicated that isophthalates can be considered non-selective among the DAG-responsive C1 domains. Based on these studies, the affinity of HMI-1a3 to the C1 domains of PKC, PKD, β 2-chimaerin and MRCK cannot however be directly compared, since the K_i values were not determined for the “non-PKC” DAG effectors. However, the similar IC_{50} values suggest that there are no major differences in its affinity to these proteins. Although the affinity of isophthalates to C1 domains of RasGRPs, DGKs and Munc13s was not investigated, based on high structural and sequence similarity of their C1 domains, it can be speculated that the same SAR model holds true with these DAG effectors as well.

Despite high conservation of the phorbol ester binding sites in C1 domain-containing proteins, there are some structural differences that lead to divergent ligand affinities of individual C1 domains (Dries et al., 2007; Rahman et al., 2013), suggesting that it may be possible to develop C1 domain ligands that are selective for a specific DAG effector. Although their development has proven difficult, some degree of selectivity has been achieved with e.g. DAG lactones (El Kazzouli et al., 2008; Comin et al., 2009). However, since the phospholipid composition of the cell membrane and the C1 domain-cell membrane interactions affect ligand recognition by the C1 domain in a significant manner, rational development of such selective compounds may be unfeasible. It has thus been suggested that a more practical approach would instead be semi-rational and based on assessing a desired biological response as a supplement or alternative to binding affinity (Blumberg et al., 2008).

6.2 Effects of isophthalate derivatives on PKC-mediated signalling

Although most of the known C1 domain ligands are PKC activators, some of them, such as AD198 and calphostin C, have been reported to inhibit PKC activity (Gopalakrishna et al., 1992a; Roaten et al., 2002). The binding studies discussed above do not clarify the functional outcome of isophthalate binding to PKC, and therefore it was necessary to investigate whether isophthalate binding leads to PKC inhibition or activation. Instead of determining the effects of isophthalates on PKC kinase activity *in vitro*, effects of isophthalates on PKC-mediated signalling were investigated in cellular context. The cell-based approach provides information in a more physiological environment, which is especially important with PKC because of its complex regulation including, for instance, translocation to different subcellular compartments. Moreover, as demonstrated with AD198, results from *in vitro* kinase activity assay do not necessarily illustrate the functional outcome in cellular context (see section 2.5.5) (Roaten et al., 2002; He et al., 2005).

The Raf–MEK–ERK1/2 cascade, which is widely involved in the regulation of cell proliferation and differentiation, represents one of the ubiquitous signalling cascades downstream of PKC. The finding that, in HeLa cells, HMI-1a3 and HMI-1b10 induced a rapid ERK1/2 phosphorylation that was at least partially dependent on PKC activity was the first proof of a PKC-modulating effect for the isophthalates. Furthermore, it demonstrated that the isophthalates can diffuse into the cell membrane and reach their intracellular target proteins. The observation that HMI-1b11 alone was unable to induce ERK1/2 phosphorylation, pointed to an unexpected difference between the highly similar isophthalate derivatives HMI-1b10 and HMI-1b11. The inhibition of PMA-induced ERK1/2 phosphorylation by HMI-1b11 suggested that HMI-1b11 may either function as a PKC antagonist or possess such a weak activating effect that it could not be detected with the method employed. Antagonism among the C1 domain-binding PKC activators has been previously reported at least

between bryostatin 1 and PMA (Szállási et al., 1994a; Szállási et al., 1994b). Contrastingly, both HMI-1a3 and HMI-1b11 induced a strong, PKC-dependent ERK1/2 phosphorylation in SH-SY5Y cells, showing that the signalling cascades activated by isophthalates differ depending on the cell line. PKC-mediated activation of the ERK1/2 cascade is known to be dependent on cell type, PKC isoforms and the nature of the stimulus (see section 2.2.4), offering an explanation for the divergent responses to HMI-1b11 in HeLa and SH-SY5Y cells, as well as for the difference observed in the prolonged ERK1/2 phosphorylation between the isophthalates.

In both cell lines, isophthalate-induced activation of the ERK1/2 cascade seems to be dependent on PKC activation. However, other signalling pathways may also contribute, since simultaneous exposure to the pan-PKC inhibitor Gö6983 was not always sufficient to achieve total inhibition of ERK1/2 phosphorylation. The fact that neither of the inactive isophthalates had an effect on ERK1/2 phosphorylation in SH-SY5Y cells however speaks for a C1 domain-dependent mechanism. Among DAG effectors, PKD represents a potential mediator for the “non-PKC” input, since it is ubiquitously expressed and known to regulate the Raf-MEK-ERK1/2 pathway in numerous cell types (Lavalle et al., 2010). The role of PKD in isophthalate-induced ERK1/2 phosphorylation was however not studied.

Effects of HMI-1b11 on PKC-dependent signalling were studied in more detail in SH-SY5Y cells. HMI-1b11 induced a rapid accumulation of PKC α into the cytoskeletal (Triton X-100-insoluble) fraction, where PKC α has previously been shown to associate with nELAV proteins and induce nELAV-dependent mRNA stabilization (Pascale et al., 2005). Also other C1 domain-targeting PKC activators are known to induce accumulation of PKC α in the cytoskeletal fraction (Szállási et al., 1994b; Pascale et al., 2005), although translocation to the plasma membrane is the most commonly observed phenomenon. Considering the cytoskeletal accumulation of PKC α in response to HMI-1b11, the subsequent finding of HMI-1b11-induced cPKC-dependent up-regulation of GAP-43 was logical. Although it was not demonstrated in these studies, the up-regulation probably occurs through PKC-dependent nELAV activation, as previously demonstrated in PC12 and SH-SY5Y cells (Mobarak et al., 2000; Pascale et al., 2005). It can also be further speculated that the effect may be specifically mediated by PKC α , since it has been shown to be the cPKC isoform responsible for activating the nELAV-mediated mRNA stabilization in SH-SY5Y cells (Pascale et al., 2005).

The above-discussed studies on PKC-mediated signalling demonstrate that the isophthalates induce PKC activation in both cell lines investigated. It is well known that prolonged PKC activation in response to C1 domain ligands leads to down-regulation of PKC protein levels by either a proteasome-independent mechanism or by the ubiquitin-proteasome pathway (Lee et al., 1996b; Leontieva and Black, 2004). However, isophthalates HMI-1a3 and HMI-1b11 did not induce down-regulation of PKC isoforms α , β , or δ in either of the cell lines studied. This may reflect their lower binding affinity for the C1 domain as compared with phorbol esters or bryostatin 1. The isophthalate-induced PKC activation may also be shorter-lived and thus insufficient to induce down-regulation thus resembling more DAG-induced than phorbol ester-evoked PKC activation.

6.3 Effects of isophthalate derivatives on cell viability and proliferation

As cancer is considered the best-validated therapeutic indication for C1 domain ligands, the effects of isophthalates on HeLa cervical carcinoma cell viability and proliferation were investigated. HeLa

cells are widely used in research focusing on signal transduction and cancer; however, they are generally not considered a proper cancer model. As the first-ever continuous cell line, HeLa cells have been grown *in vitro* for several decades in laboratories world-wide (Jones, 1997). Therefore, it is probable that numerous clones exist that diverge substantially from each other and from the primary tumour from which the cells were isolated in 1951. However, comprehensive spectral karyotyping of the HeLa CCL2 cell line used in these studies showed that the HeLa genome has been unexpectedly stable during years of cultivation (Macville et al., 1999). Moreover, the genomic alterations in HeLa cells correlated closely to alterations in samples from advanced stage cervical carcinoma, indicating that they may have been present already in the primary tumour and that they can be considered highly relevant to the pathology of cervical carcinoma. Additionally, the antiproliferative effects of isophthalates in SH-SY5Y neuroblastoma cells were assessed at the same time their effects on cell morphology were investigated.

In studies performed in HeLa cells various complementary methods were used in order to be able to interpret the results also from a mechanistic point of view (Kim et al., 2009). Of the cell viability tests used, the LDH assay measures cell membrane damage and can be considered a measure of necrotic cell death, while the MTT assay represents a measure of mitochondrial reduction capacity, which is attenuated in both necrosis and apoptosis, but also reflects cell proliferation. Thymidine incorporation assay that measures DNA replication is a gold standard method for assessing inhibition of cell proliferation (Griffiths and Sundaram, 2011). The Cell-IQ[®] analysis involves computer vision-based cell recognition from automatically acquired time-lapse series of phase contrast microscopic images of cell cultures. It also allows for classification of cells to e.g. healthy and dead according to cell morphology, thus providing information on cell proliferation, viability and morphology (Toimela et al., 2008; Pennanen et al., 2011). Quantification of cell proliferation and morphology with Cell-IQ[®] however requires development of a specific analysis protocol for each cell line to achieve optimal cell recognition. The present results with HMI-1a3 show close correlation between thymidine incorporation assay and cell proliferation analysis with Cell-IQ[®], as reported previously (Toimela et al., 2008), confirming the accuracy of Cell-IQ[®] analysis.

While many of the active isophthalates were antiproliferative and cytotoxic in HeLa cells, none of the isophthalate derivatives with poor affinity to the C1 domain inhibited cell proliferation or induced cytotoxicity, suggesting a C1 domain-dependent effect. Furthermore, the finding that not all active isophthalates shared the antiproliferative and cytotoxic properties of HMI-1a3 indicates that there are differences in signalling elicited by isophthalate exposure in HeLa cells, as observed in ERK1/2 phosphorylation studies. HMI-1a3-induced cytotoxicity emerged in the MTT assay at approximately 10-fold lower concentrations than the cytotoxic or antiproliferative effects in Cell-IQ[®] or thymidine incorporation assays suggesting that mitochondrial function is compromised also in cells that are not yet dead. The mechanism of HMI-1a3-induced toxicity may thus involve induction of mitochondrial dysfunction. HMI-1a3 also inhibited SH-SY5Y cell proliferation, although less potently than that of HeLa cells. However, while HMI-1b11 had little effect on HeLa cell proliferation, it exhibited a clear antiproliferative effect in SHSY-5Y cells without inducing cell death. This correlates with HMI-1b11-induced ERK1/2 phosphorylation and implies that also the antiproliferative responses to isophthalates are cell line-dependent.

The mechanistic studies employing a pharmacological approach with protein kinase inhibitors and PMA as well as a genetic approach with RNA interference against specific PKC isoforms were unable to decipher the antiproliferative mechanism of HMI-1a3. Since inhibition or activation of PKC or

inhibition of PKD or MRCK had no effect on the antiproliferative response to HMI-1a3, the response seems to be independent of the activity of these kinases. Also the ERK1/2 cascade seems to be dispensable for the isophthalate-induced response even though it is a well-known mediator of mitogenic signalling. Furthermore, PKC α and PKC δ are dispensable for HMI-1a3-induced inhibition of cell proliferation, since knocking down these proteins one by one with RNAi had no effect on the antiproliferative response. The C1 domain-containing proteins targeted by the isophthalates regulate numerous interconnecting and convergent signal transduction pathways, which contribute to cell survival, proliferation and apoptosis (Fig. 16) (Brose et al., 2004). Therefore, activation or inhibition of one of the isophthalate target proteins may be compensated by alterations in other pathways. Furthermore, since at least some of these pathways are regulated by several DAG effectors at different levels, isophthalates may interfere with a certain signalling route at several points. Moreover, as the C1 domain also plays an important role in mediating protein-protein interactions (Colón-González and Kazanietz, 2006), it is possible, that the effects of isophthalates result from alterations in protein-protein interactions independently of changes in enzyme activity. It may therefore be unfeasible to decipher the exact mechanism-of-action for the isophthalates.

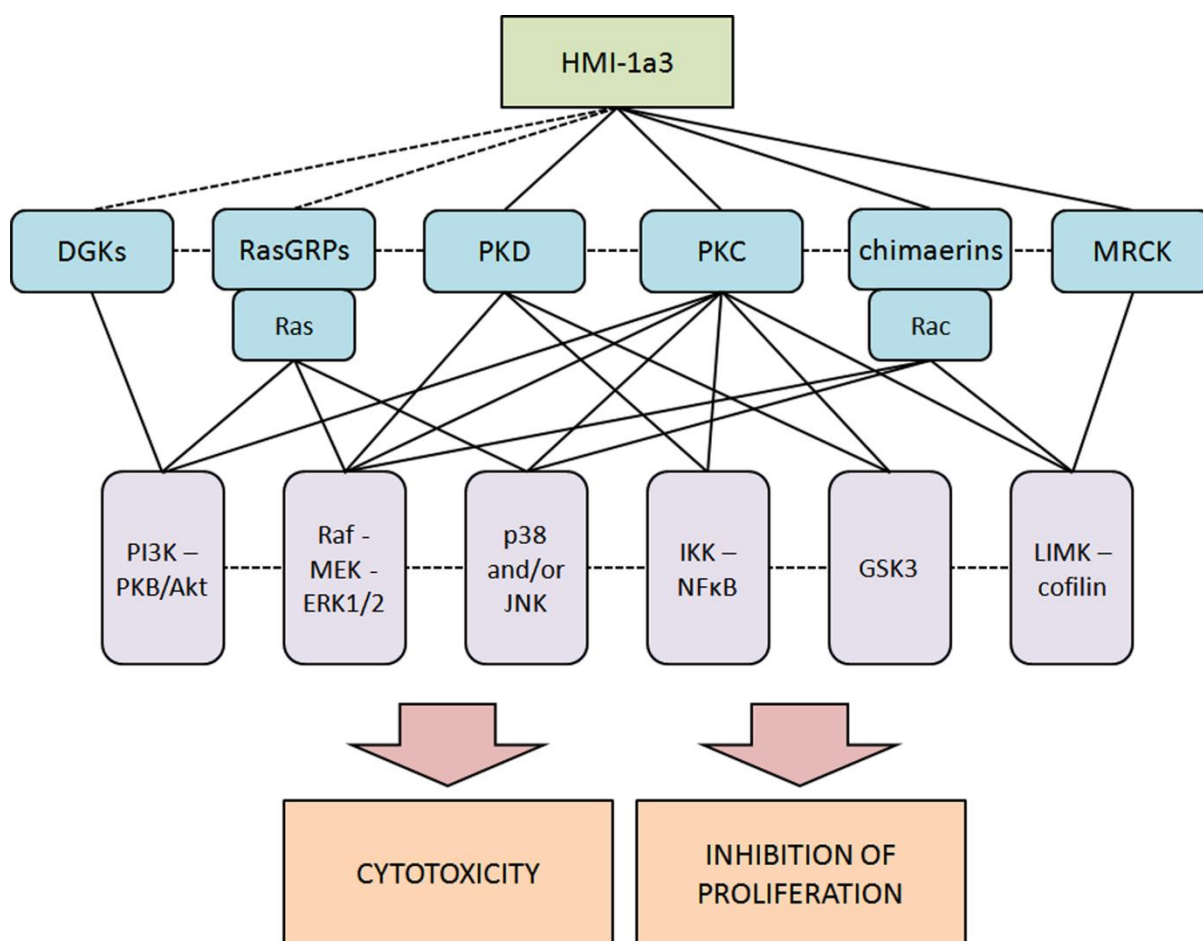

Figure 17. Potential signalling routes mediating the effects of HMI-1a3 on cell survival and proliferation. Demonstrated binding of HMI-1a3 to the targets presented is indicated with solid lines, and anticipated binding to other DAG effectors with dashed lines. The dashed lines connecting DAG effectors illustrate direct and indirect cross-talk among C1 domain-containing proteins. The following connections to signalling cascades symbolise the possible signalling routes by which the HMI-1a3-induced cytotoxic and antiproliferative effects may be mediated and are based on citations in chapters 2.2 and 2.3. The dashed lines connecting these signalling routes illustrate cross-talk among them.

Despite inconclusive results in mechanistic studies, the complete lack of cytotoxicity and antiproliferative effects in response to the inactive isophthalate derivatives strongly suggests that the effect is C1 domain-dependent and does not result from an unspecific effect related to the overall chemical structure of isophthalates. However, it seems probable that the antiproliferative and cytotoxic effects of HMI-1a3 are not mediated by a single C1 domain-containing protein, but rather that they result from modulation of several DAG effectors (Fig. 17). More studies are needed to identify the signalling routes by which HMI-1a3 induces its antiproliferative effects. Nevertheless, the results presented here suggest that HMI-1a3 exhibits potential as a lead molecule for cancer drug development, which is supported by a study reporting that it induces apoptosis in HL60 leukaemia cells but not in Swiss 3T3 fibroblasts (Galkin et al., 2008). To substantiate the potential of HMI-1a3 or other isophthalates as lead compounds for cancer drug development, further studies in other cancer cell lines and corresponding non-cancerous cell lines, as well as *in vivo* experiments with mouse xenograft models are required.

6.4 Effects of isophthalate derivatives on cell morphology and cytoskeleton

Cell morphology and motility are controlled by the organization of cytoskeletal components: the microfilaments (actin filaments), the intermediate filaments and the microtubules. Several classes of DAG effectors contribute to the regulation of cytoskeleton and may thereby influence cell shape, adhesion and motility. Moreover, phorbol esters are known to modulate cell morphology and motility through their effects on actin cytoskeleton (Larsson, 2006). Therefore, it was not a surprise that active isophthalates induced morphological changes in both cell lines studied. In HeLa cells HMI-1a3 induced prominent cell elongation, while HMI-1b11 had only a slight elongation-inducing effect at the highest concentration studied. Contrastingly, both compounds supported neurite outgrowth with similar potency in SH-SY5Y cells. Since none of the inactive isophthalate derivatives influenced cell morphology in either of the cell lines, the mechanism seems to be C1 domain-dependent. Although the effects on cell morphology correlate with the ability of isophthalates to induce ERK1/2 phosphorylation in the corresponding cell line, ERK1/2 signalling was found to be dispensable for the morphological change in HeLa cells. The role of ERK1/2 signalling in neurite outgrowth in SH-SY5Y cells was not investigated.

The morphological change was more striking in HeLa cells, where cell elongation, emergence of cellular protrusions and diminished cell spreading occurred as a result of major reorganization of actin cytoskeleton. The observed loss of focal adhesions may account for the diminished cell spreading, since focal adhesions, which connect the cytoskeleton to the extracellular matrix through integrins, are essential for cell adhesion and spreading (Wolfenson et al., 2009). The observed disruption of the contractile stress fibre network may increase the assembly of protrusive arrays of actin filaments thus inducing cellular protrusions; on the other it may decrease cell contractility resulting in cell elongation (Tojkander et al., 2012). Although not addressed in the present studies with SH-SY5Y cells, neurite outgrowth has been shown to be accompanied with loss of stress fibres in several cell lines (Ling et al., 2004; Troll r and Larsson, 2006), suggesting that similar changes in cytoskeleton may be behind the morphological responses in HeLa and SH-SY5Y cells.

The prominent nuclear translocation of cofilin-1 in response to HMI-1a3 suggests that cofilin-1 plays a role in mediating isophthalate-induced cellular effects. In addition to its well-established role in

regulating actin filament dynamics, cofilin is also implicated in nuclear import of actin, induction of apoptosis and phospholipid signalling (Paavilainen et al., 2004; Bernstein and Bamburg, 2010). Nuclear translocation of cofilin-1 is known to take place in cellular stress conditions and to regulate cofilin-actin rod formation, which is imperative for cell survival during stress (Munsie et al., 2012). Nuclear cofilin-1 also regulates transcription elongation by controlling dynamics of gene-associated actin (Obrdlik and Percipalle, 2011). The HMI-1a3-evoked nuclear accumulation of cofilin-1 may thus be connected to the prominent HMI-1a3-induced changes in gene expression and/or illustrate an unspecific response to stressful conditions.

The studies aimed to characterize the signalling pathways mediating HMI-1a3-induced cell elongation in HeLa cells pointed to a mechanism that is independent of ERK1/2 signalling, of the catalytic activity of PKC and PKD, and of the presence of PKC isoforms α and δ . However, the morphological response seems to be at least partially mediated by MRCK, since the MRCK inhibitor chelerythrine attenuated HMI-1a3-induced cell elongation. This is consistent with previous studies showing a crucial role for MRCK in cytoskeletal reorganization (Leung et al., 1998), cell spreading (Groeger and Nobes, 2007) and, particularly, in controlling elongated morphology of tumour cells (Wilkinson et al., 2005). Furthermore, Cdc42, the upstream regulator of MRCK has been reported to mediate stress fibre loss in NIH3T3 fibroblasts (Coghlan et al., 2000). The MRCK inhibitor chelerythrine has been shown not to inhibit 70 other protein kinases including PKC (Lee et al., 1998; Davies et al., 2000; Tan et al., 2011) and can thus be considered a fairly selective MRCK inhibitor. However, the role of MRCK in mediating HMI-1a3-induced cell elongation should be verified using RNAi or dominant negative MRCK constructs.

Interestingly, MRCK is one of the two DAG effectors (the other one being PKD) that regulate the phosphorylation state of cofilin-1 (see Fig. 18). MRCK α phosphorylates and activates LIM kinases, which in turn phosphorylate cofilin (Sumi et al., 2001; Bernstein and Bamburg, 2010). However, despite inducing prominent changes in cofilin-1 localization and potentially activating MRCK to induce cell elongation, HMI-1a3 had no significant effect on the level of phosphorylated cofilin-1. Spatial control of actin dynamics is crucial for appropriate function of the cytoskeleton, and cofilin phosphorylation has also been reported to occur in a highly localized manner (van Rheenen et al., 2009; Bernstein and Bamburg, 2010). Small but locally significant changes in cofilin-1 phosphorylation may not be detectable by the methods employed in this study, and the results do not rule out local changes in cofilin-1 phosphorylation. Further studies are needed to clarify the role of cofilin-1 in isophthalate-induced morphological changes.

The human neuroblastoma cell line SH-SY5Y is a well-characterized and widely used model for neuronal differentiation (Påhlman et al., 1990; Agholme et al., 2010), and PKC activation by phorbol esters is known to induce differentiation in neuroblastoma cell cultures (Söderholm et al., 2001; Trollér et al., 2001). Classical PKC isoforms have been suggested to play a role in regulating neuroblastoma cell proliferation and survival, while novel PKCs have been demonstrated to mediate neurite outgrowth (Zeidman et al., 1999a; Zeidman et al., 1999b). Furthermore, ERK1/2 signalling has been reported to contribute to SH-SY5Y cell differentiation (Monaghan et al., 2008). The isophthalate-induced responses in SH-SY5Y cells – neurite outgrowth, inhibition of cell proliferation and up-regulation of GAP-43 – are all hallmarks of neuroblastoma cell differentiation (Agholme et al., 2010).

Despite the fact that isophthalate-induced SH-SY5Y cell differentiation correlated with accumulation of PKC α in the cytoskeletal fraction, PKC-dependent activation of ERK1/2 signalling and GAP-43 up-regulation, a definite role for PKC in neurite outgrowth and inhibition of cell proliferation was not demonstrated. Based on the present results with GAP-43 expression and abundant literature implying an important role for PKC in neurite outgrowth, the response can however be speculated to be PKC-dependent. PKC-induced neurite outgrowth in neuroblastoma and non-malignant cells with neuronal differentiation potential is specifically dependent on the regulatory region of PKC (Zeidman et al., 1999a; Ling et al., 2004). Furthermore, Cdc42 has been identified as an important downstream factor mediating the morphological and cytoskeletal effects of PKC (Troll r and Larsson, 2006) raising the possibility that MRCK may also play a role in neurite outgrowth, which would be logical considering its central role in the regulation of actin cytoskeleton.

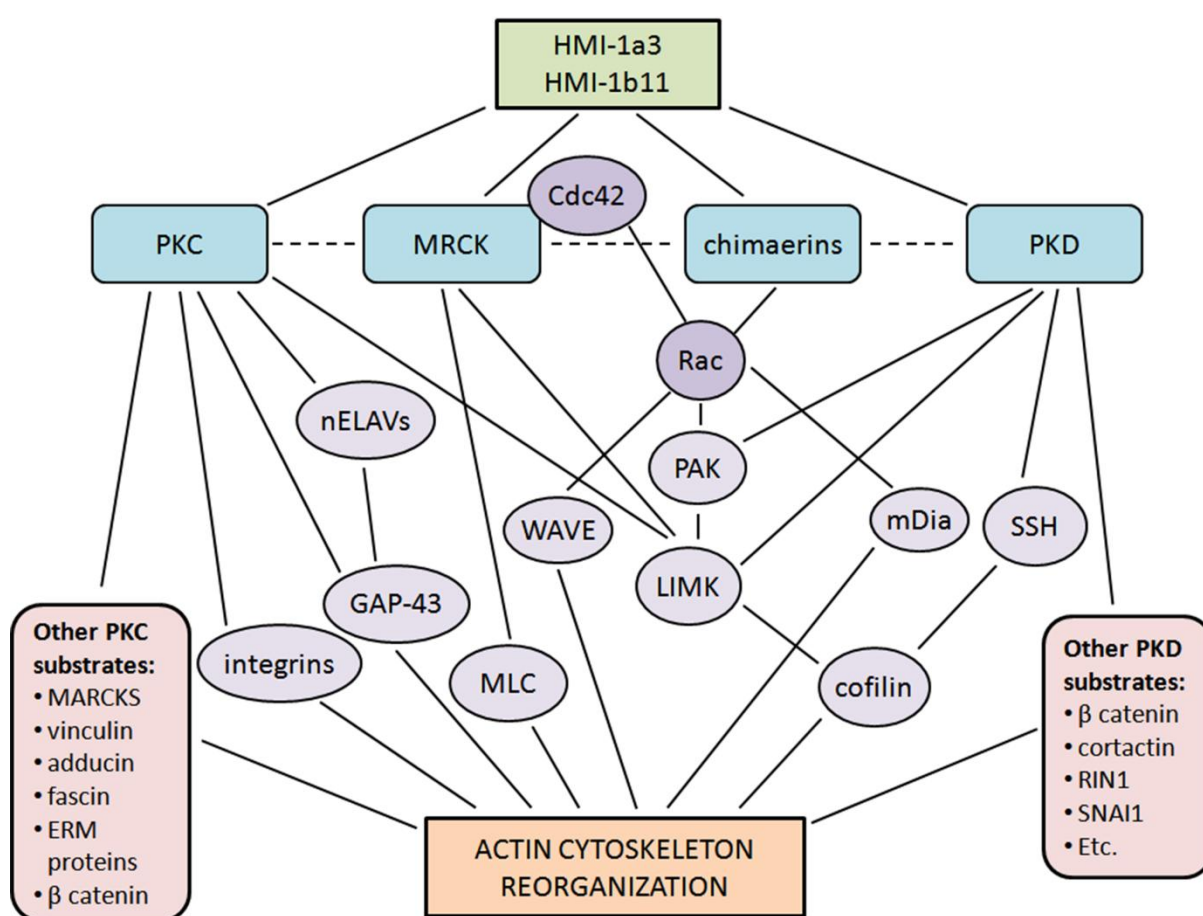

Figure 18. Potential signalling routes mediating the effects of isophthalates on actin cytoskeleton. Binding of isophthalates to the targets presented has been demonstrated in these studies. The following interactions symbolise the possible signalling routes by which the isophthalate-evoked cytoskeletal changes may be mediated. The dashed lines connecting DAG effectors illustrate direct and indirect cross-talk among the C1 domain-containing proteins. The Figure is based on citations in chapters 2.2 and 2.3. ERM, ezrin-radixin-moesin family of proteins; GAP-43, growth associated protein 43; LIMK, Lim domain kinase; MARCKS, myristoylated alanine-rich C-kinase substrate; mDIA, protein diaphanous homolog; MLC, myosin light chain; nELAVs, neuronal embryonic lethal vision proteins; PAK4, p21-activated kinase 4; RIN1, Ras and Rab interactor 1; SSH, slingshot family of phosphatases; WAVE, Wiskott-Aldrich syndrome protein family Verprolin-homologous protein.

Although probably representing different phenomena, the isophthalate-induced changes in HeLa and SH-SY5Y cell morphology include common features: HeLa cell elongation was accompanied with elongated cell processes resembling neurite outgrowth observed in SH-SY5Y cells. Furthermore, based on the present results with HeLa cells and the literature concerning neuroblastoma cells, stress fibre loss and involvement of MRCK are potential connecting factors. The mechanisms responsible for mediating the morphological changes in the two cell lines may thus be at least partially similar. The potential signalling routes by which isophthalate-induced morphological changes may be mediated are presented in Figure 18.

6.5 General discussion

Considering PKC-related drug development, the C1 domain provides several advantages over the kinase domain as a drug target. Firstly, the human genome contains more than 500 protein kinases (Manning et al., 2002) with highly conserved kinase domains, and therefore the development of specific compounds targeted to the catalytic site has proven to be extremely challenging (Karaman et al., 2008). In contrast, there are only seven families of proteins with a DAG-responsive C1 domain. Despite high conservation also among the C1 domains, the number of potential off-target interactions is considerably smaller with C1 domain-targeting compounds than with those targeting the catalytic site. Secondly, targeting the kinase domain only enables the development of inhibitors, while targeting the C1 domain provides a possibility to develop activators as well as inhibitors. By inducing a conformational change similar to that induced by DAG, C1 domain ligands can activate PKC; however, they can also inhibit its activity for example by targeting the protein to an inappropriate cellular compartment and thereby directing it away from its substrates (Blumberg et al., 2008). Furthermore, protein-protein interactions of the regulatory domains of PKCs seem to mediate biological responses independently of the catalytic activity of the enzyme (Zeidman et al., 1999a; Cameron et al., 2008; Cameron and Parker, 2009; Jacob et al., 2010), and compounds that bind to the C1 domain may be useful in modulating such interactions. Regarding PKC, the kinase domain and the C1 domain are not however the only potential drug targets. PKC isoform-specific inhibitors and activators have been developed by targeting the protein-protein interactions of e.g. PKCs and the respective RACKs (see Mochly-Rosen et al., 2012). These molecules are however peptides, which may hinder their feasibility as drugs.

Although pursuit of specificity has generally been the ultimate goal in rational drug development, it has become clear that cancer can rarely be beaten with a drug affecting only a single signalling pathway. Cancer cells usually exhibit deregulation in numerous signal transduction cascades, and drug resistance resulting from further alterations is a common cause of treatment failure. Therefore drugs that modulate several distinct molecular targets involved in the malignant pathology have been suggested to become a breakthrough in the treatment of malignancies (Daub et al., 2004; Sarkar and Li, 2009). As most of the DAG effectors participate in mediating mitogenic signalling, the possibility to modulate several of them simultaneously with compounds that bind to the C1 domain may be beneficial when targeting cancer. Furthermore, the cross-talk between DAG-mediated pathways (Brose et al., 2004; Spitaler and Cantrell, 2004; Troll er and Larsson, 2006) highlights an opportunity to intervene with a certain signalling cascade at more than one point and thereby reinforce the outcome. For example, PKC is known to phosphorylate and activate PKD (Waldron and Rozengurt, 2003), to phosphorylate and activate RasGRP3 thus enhancing Ras-ERK signalling

(Teixeira et al., 2003), and to phosphorylate and negatively regulate β 2-chimaerin facilitating Rac activation and mitogenic signalling (Griner et al., 2010). Consequently, C1 domain ligands may exhibit anti-cancer efficacy by affecting several mitogenic signalling routes and by targeting many of those at various levels. The non-selective binding profile of isophthalates among the C1 domains thus enables them to target simultaneously several proteins that play a role in cancer development.

Neurodegenerative diseases, such as AD, are a major cause of cognitive decline and mortality. Since there is no treatment that could stop the neuronal loss characteristic to these diseases, therapies that can help to preserve neurons and/or neuronal connections are urgently needed. Learning and memory are based on synaptic plasticity, and one of the key proteins mediating neuroplasticity is GAP-43 (reviewed in Benowitz and Routtenberg, 1997). PKC activity has been shown to control learning and memory by regulating GAP-43 functions at two different levels: its expression levels through nELAV-mediated mRNA stabilization and its activity through direct phosphorylation (Pascale et al., 2004; Pascale et al., 2005; Holahan and Routtenberg, 2008). PKC activation enhances cognition and improves learning also through other mechanisms, and PKC has therefore been classified as one of the “cognitive kinases” (Schwartz, 1993; Govoni et al., 2010). In addition to its beneficial effects on cognition, PKC regulates several processes linked to AD pathophysiology (Fig. 5), and the C1 domain-targeted PKC activator bryostatin 1 has been shown to reduce the A β burden and increase the lifespan of AD transgenic mice (Etcheberrigaray et al., 2004). C1 domain ligands, such as HMI-1b11, may thus both inhibit the progression of neurodegeneration in AD and help to restore lost neuronal connections by inducing neuronal sprouting and synaptogenesis. Further studies in both *in vitro* and *in vivo* models are, however, needed to clarify the potential of HMI-1b11 as a lead molecule for AD drug development.

Isophthalate derivatives characterized in this thesis do not bind to the C1 domain as potently as many other C1 domain ligands. However, their cellular effects occur at the same concentration range as binding *in vitro* implying good cell permeability and thus availability to their target proteins. It is however noteworthy that DAG lactones and benzolactams with low nanomolar affinities for the C1 domain *in vitro* produce their cellular effects (such as PKC translocation, inhibition of cancer cell proliferation or induction of apoptosis) at micromolar concentrations (Kozikowski et al., 1997; Garcia-Bermejo et al., 2002; Truman et al., 2009). Thus, based on the evidence presented in this thesis, in the cellular context the isophthalates work at similar concentrations as other synthetic C1 domain ligands.

Despite very similar chemical structures, the isophthalates studied here exert diverging effects in cells. Some of the differences correlate closely with binding affinity to the C1 domain: the compounds that exhibit no binding *in vitro* are devoid of cytotoxic, antiproliferative and differentiation-inducing effects in the cell lines studied. Also the gene expression microarray results highlight the differences between HMI-1a3 and its inactive derivative NI-15e. Although C1 domain-independent mechanisms cannot be excluded, these results strongly suggest a C1 domain-mediated mechanism of action for the active isophthalates. However, the divergent effects of HMI-1a3 and HMI-1b11 cannot be readily explained by the binding affinity. Whether the difference observed in maximal [3 H]PDBu displacement from PKC δ plays a role was not addressed. Furthermore, the differences in the responses observed in the two cell lines, exemplified by the effects of HMI-1b11 on ERK1/2 phosphorylation or gene expression (significant changes in 1071 vs. 304 genes in SH-SY5Y cells and HeLa cells, respectively), speak for cell line-specific modulation of downstream signalling typical for e.g. PKC. However, the cellular responses to isophthalates seem to differ substantially

from those induced by other C1 domain ligands, highlighting the need for further studies to elucidate the signalling pathways that mediate isophthalate-evoked responses.

When targeting the C1 domain, the potential for tumour-promotion has to be kept in mind. Although not all C1 domain ligands are tumour promoters like phorbol esters (Blumberg et al., 2008; Nelson and Alkon, 2009; Boije af Gennäs et al., 2011), such a property would hinder (although not totally preclude) the use of any therapeutic. The divergent patterns of PKC isoform translocation and down-regulation induced by C1 domain-targeting PKC activators correlate with tumour promotion (Nelson and Alkon, 2009). Particularly, there is substantial evidence that the pattern of PKC δ translocation and down-regulation is connected to tumour promotion (Lu et al., 1997; Bögi et al., 1998; Wang et al., 1999). The effects of isophthalates on PKC δ translocation were not investigated; however, since HMI-1a3 and HMI-1b11 did not induce down-regulation of PKC δ , it seems likely that they are devoid of tumour-promoting activity. On the other hand, phorbol ester-induced tumour promotion may also be regulated by other DAG effectors than PKC, such as RasGRPs (Tuthill et al., 2006).

Similarly to other xenobiotics, the use of dialkyl 5-(hydroxymethyl) isophthalates involves a risk of various other toxicities than tumour promotion discussed above. Isophthalates are chemically related to orthophthalates (commonly referred to as phthalates), which are widely used as plasticizers in polyvinyl chloride (PVC) plastics. Some, but not all, orthophthalates are suspected to disturb normal endocrine function in humans and some are known to cause reproductive and developmental toxicity in animals (Heudorf et al., 2007). Isophthalates are not used in chemical industry like orthophthalates, and their toxicological profiles have therefore not been investigated. Despite structural differences between iso- and orthophthalates, the risk of similar adverse effects cannot however be ruled out. Some of the isophthalate derivatives described in this thesis, including HMI-1a3, were shown to be devoid of mutagenic potential in a miniaturized Ames test (Galkin et al., 2008). Since the isophthalate derivatives act as allosteric modulators of various target proteins, their potential adverse effects are difficult to predict. For example, based on their PKC-activating properties, the isophthalates can be speculated to bear a risk for cardiotoxicity through activation of PKC δ (Inagaki et al., 2006). By contrast, activation of PKC ϵ would be cardioprotective, and thus the outcome of isophthalate exposure is unpredictable. The experience of C1 domain ligand-induced adverse effects in clinical settings is limited to ingenol-3-angelate and bryostatin 1. Ingenol-3-angelate is used topically and has mainly caused local skin reactions at the application site, while the dose-limiting adverse effect in the systemic use of bryostatin 1 has consistently been myalgia of an unknown aetiology (Clamp and Jayson, 2002). The studies in *in vivo* models will be important in deciphering the toxicological risks related to isophthalate derivatives.

7. SUMMARY AND CONCLUSIONS

The C1 domain of PKC and other DAG effectors represents an attractive drug target, especially for cancer and Alzheimer's disease. The aim of these studies was to investigate the structure-activity relationships and *in vitro* pharmacology of a novel group of C1 domain ligands, derivatives of isophthalic acid. The major findings are as follows:

- 1) The isophthalate derivatives bind to PKC and other DAG effectors studied in a low micromolar concentration range. The following structural elements are indispensable for binding to the C1 domain: a hydroxymethyl group at position C5 of the aromatic ring, ester groups on positions C1 and C3 of the aromatic ring, and sufficient hydrophobicity of the ester substituents.
- 2) Some of the active isophthalates, most potently HMI-1a3, inhibit proliferation of HeLa cervical cancer cells and induce non-necrotic death through a thus far unresolved mechanism.
- 3) Some of the active isophthalates, most potently HMI-1a3, induce prominent cytoskeleton reorganization and concomitant cell elongation in HeLa cells. The effect is at least partially mediated by MRCK.
- 4) Active isophthalates, exemplified by HMI-1b11, induce differentiation of SH-SY5Y neuroblastoma cells. The cellular response is associated with activation of PKC and ERK1/2 signalling as well as up-regulation of GAP-43.

In conclusion, dialkyl 5-(hydroxymethyl)isophthalates with a considerably simpler synthesis route compared to other C1 domain ligands represent a promising new template for PKC and C1 domain-targeted drug development. Of the first-generation isophthalates explored in this thesis, HMI-1a3 was identified as a potential lead molecule for cancer-related drug discovery because of its prominent antiproliferative activity in HeLa cells. HMI-1b11 was identified as a non-cytotoxic agent that induces differentiation and supports neurite growth in neuroblastoma cells, and it may thus have potential in drug development related to neurodegenerative diseases such as AD. However, further work is needed to improve the selectivity and potency of isophthalate derivatives, to clarify their mechanism of action in both HeLa and SH-SY5Y cells, and to assess their efficacy in cell-based and *in vivo* disease models.

8. ACKNOWLEDGEMENTS

The work described in this thesis has been carried out during years 2004-2013 at the Division of Pharmacology and Toxicology, Faculty of Pharmacy, University of Helsinki. It was a part of a multi-disciplinary research project, through which I had the opportunity to work with and learn from experts on various subjects. The work could not have been completed without the help and support of numerous persons, to whom I wish to express my sincere gratitude.

The research and doctoral training were financially supported by the 6th European Community Framework Programme "Protein Kinases – Novel Drug Targets of the Post-genomic Era" (research project 503467), the Finnish Pharmaceutical society, Alfred Kordelin Foundation, the Finnish Cultural Foundation, Päivikki and Sakari Sohlberg Foundation, Magnus Ehrnrooth Foundation, Oskar Öflund Foundation, Ida Montin Foundation, the FinPharma Doctoral Program and the Society for Drug Research, all of which are gratefully acknowledged.

I express my great appreciation to my supervisor Professor Raimo K. Tuominen, Head of Division of Pharmacology and Toxicology, for welcoming me into his group and for providing funding and excellent research facilities for this work. Raimo, your encouragement, support and guidance throughout the years were essential for the completion of this work. I especially value the perspective you have given and your advice on scientific writing. I also warmly acknowledge the fact that despite your busy schedule you always managed to find time for a discussion when I needed your support. Moreover, I am thankful for having had the opportunity to also take responsibility for teaching.

I am deeply indebted to my supervisor Dr Elina Ekokoski for her support and guidance during the years she worked at the division and for her dedication to this project also when working outside the university. Elina, I have learned so much from you and your enthusiasm in science has been the best example I could have asked for! It goes without saying that this thesis would not have been completed without your help. I also value your friendship and all the scientific and non-scientific discussions we have had during the years.

I thank the reviewers of my thesis, Professor Jyrki Kukkonen and Adjunct professor Päivi Koskinen, for devoting their time for thorough review of the manuscript and for their valuable comments and suggestions. I acknowledge Professor Pekka Lappalainen and Adjunct professor Katri Koli for their valuable remarks at the evaluation of my research plan. I also wish to express my appreciation to Professor Kid Törnquist for his constructive comments during the evaluation of my research plan and for agreeing to act as my opponent at the public defence of this dissertation.

Among my collaborators, I first and foremost wish to thank the members of the PKC club: Professor Jari Yli-Kauhaluoma, Adjunct professor Moshe Finel, Mr Olli Aitio and Dr Gustav Boije af Gennäs. Jari, your enthusiasm in science has been an inspiration to me and I warmly acknowledge your support throughout the project. Moshe, thank you for sharing your expertise in molecular biology and for your support and guidance especially during the first years of my research career. Olli, without your initial work on the design of the isophthalates this thesis would not exist; thank you for the collaboration. Gusse, your synthetic work was also essential for this project, and your constantly positive attitude is something I really look up to.

Among my other collaborators and coauthors, I thank Prof. Pekka Lappalainen and Ms Gergana Gateva for sharing their expertise on cytoskeleton during our collaboration on the HeLa cell project, as well as my collaborators at the University of Pavia, Italy - Prof. Alessia Pascale, Dr Lauramaria Amadio, Dr Cecilia Osera, Prof. Simona Collina, Prof. Daniela Rossi and Dr Raffaella Gaggeri - for the collaboration on the SH-SY5Y cell project and for their hospitality during my visit in Pavia. Also all the M.Sc. students who worked in the PKC project, in particular Marja Ahti and Salla Pankka (née Sorvari), are kindly acknowledged for their contribution. Although not all the results ended up in the publications, their projects and contributions played an important role in forming the bigger picture.

I appreciate the excellent technical assistance from Marjo Vaha, Kati Rautio, Johanna Mosorin, Minna Baarman and Tarja Välimäki. In particular, the optimized pipeline processing of binding assay samples and the hours spent pipetting and incubating in the isotope laboratory with Marjo will never be forgotten. I am thankful to Dr Kimmo Tanhuanpää and Mr Mika Molin for their help in imaging and image analysis. I also wish to thank Adjunct professor Petteri Piepponen for his advice on statistical analysis and Adjunct professor Outi Salminen for her support and for sharing her expertise in teaching. Dr Milla Summanen is warmly acknowledged for the fruitful discussions on PKC during the time she worked at the division to finalize her thesis.

I am grateful to all my current and former colleagues at the Faculty of Pharmacy, especially at the Division of Pharmacology and Toxicology for creating a pleasant and inspiring working environment. The fact that I don't remember a single boring workday during this project cannot be only attributed to the project itself (or my lousy memory), but also to the fact that I have had the pleasure of working with great people, all of whom I regrettably cannot mention by name. In particular, I wish to thank Tanja Kivinummi, Kristiina Kaste, Merja Voutilainen, Susanne Bäck, Reeta Talka, Kati Rautio and Marjo Vaha for their friendship and support during the scientific and non-scientific ups and downs of this journey.

I am thankful to all my friends outside the university for dragging me out of the lab every once in a while and for sticking by me all these years. Especially the support from Meri Sippel and Sanna Ruotsalainen is heartily acknowledged.

I am forever grateful to my parents Ritva and Risto Talman, my sister Iiris and my brother Aarne, as well as their spouses, for their unconditional encouragement and support. I also warmly acknowledge the love and support from my mother-in-law Anna-Kaisa Järvinen and my late father-in-law Ilkka Järvinen.

My dearest thanks belong to the love of my life, my best friend and my husband, Jussi Järvinen - this work would not have been completed without his support. Jussi, with you I've always known that I have a shoulder to lean on to, no matter what the life throws at me. Thank you for your confidence in me, for your patience with this project and for reminding me time and time again that life does also exist outside the academia.

Vantaa, October 2013



9. REFERENCES

- Abeliovich A, Paylor R, Chen C, Kim JJ, Wehner JM, Tonegawa S (1993) PKC γ mutant mice exhibit mild deficits in spatial and contextual learning. *Cell* 75: 1263-71.
- Adachi R, Krilis SA, Nigrovic PA, Hamilton MJ, Chung K, Thakurdas SM, Boyce JA, Anderson P, Stevens RL (2012) Ras guanine nucleotide-releasing protein-4 (RasGRP4) involvement in experimental arthritis and colitis. *J Biol Chem* 287: 20047-55.
- Afrasiabi E, Ahlgren J, Bergelin N, Törnquist K (2008) Phorbol 12-myristate 13-acetate inhibits FRO anaplastic human thyroid cancer cell proliferation by inducing cell cycle arrest in G1/S phase: Evidence for an effect mediated by PKC δ . *Mol Cell Endocrinol* 292: 26-35.
- Agholme L, Lindström T, Kågedal K, Marcusson J, Hallbeck M (2010) An *in vitro* model for neuroscience: Differentiation of SH-SY5Y cells into cells with morphological and biochemical characteristics of mature neurons. *J Alzheimers Dis* 20: 1069-82.
- Ahmed S, Kozma R, Monfries C, Hall C, Lim HH, Smith P, Lim L (1990) Human brain n-chimaerin cDNA encodes a novel phorbol ester receptor. *Biochem J* 272: 767-73.
- Alkon DL, Sun MK, Nelson TJ (2007) PKC signaling deficits: A mechanistic hypothesis for the origins of Alzheimer's disease. *Trends Pharmacol Sci* 28: 51-60.
- Amadio M, Pascale A, Wang J, Ho L, Quattrone A, Gandy S, Haroutunian V, Racchi M, Pasinetti GM (2009) nELAV proteins alteration in Alzheimer's disease brain: A novel putative target for amyloid- β reverberating on A β PP processing. *J Alzheimers Dis* 16: 409-19.
- Ananthanarayanan B, Stahelin RV, Digman MA, Cho W (2003) Activation mechanisms of conventional protein kinase C isoforms are determined by the ligand affinity and conformational flexibility of their C1 domains. *J Biol Chem* 278: 46886-94.
- Areces LB, Kazanietz MG, Blumberg PM (1994) Close similarity of baculovirus-expressed n-chimaerin and protein kinase C α as phorbol ester receptors. *J Biol Chem* 269: 19553-8.
- Augustin I, Rosenmund C, Südhof TC, Brose N (1999) Munc13-1 is essential for fusion competence of glutamatergic synaptic vesicles. *Nature* 400: 457-61.
- Avkiran M, Rowland AJ, Cuello F, Haworth RS (2008) Protein kinase D in the cardiovascular system: Emerging roles in health and disease. *Circ Res* 102: 157-63.
- Baier G, Wagner J (2009) PKC inhibitors: Potential in T cell-dependent immune diseases. *Curr Opin Cell Biol* 21: 262-7.
- Barker WW, Luis CA, Kashuba A, Luis M, Harwood DG, Loewenstein D, Waters C, Jimison P, Shepherd E, Sevush S, Graff-Radford N, Newland D, Todd M, Miller B, Gold M, Heilman K, Doty L, Goodman I, Robinson B, Pearl G, Dickson D, Duara R (2002) Relative frequencies of Alzheimer disease, Lewy body, vascular and frontotemporal dementia, and hippocampal sclerosis in the state of Florida brain bank. *Alzheimer Dis Assoc Disord* 16: 203-12.
- Baron CL, Malhotra V (2002) Role of diacylglycerol in PKD recruitment to the TGN and protein transport to the plasma membrane. *Science* 295: 325-8.
- Basu A, Lu D, Sun B, Moor AN, Akkaraju GR, Huang J (2002) Proteolytic activation of protein kinase C- ϵ by caspase-mediated processing and transduction of antiapoptotic signals. *J Biol Chem* 277: 41850-6.
- Basu J, Shen N, Dulubova I, Lu J, Guan R, Guryev O, Grishin NV, Rosenmund C, Rizo J (2005) A minimal domain responsible for Munc13 activity. *Nat Struct Mol Biol* 12: 1017-8.
- Battaini F, Pascale A, Lucchi L, Pasinetti GM, Govoni S (1999) Protein kinase C anchoring deficit in postmortem brains of Alzheimer's disease patients. *Exp Neurol* 159: 559-64.
- Beg AA, Sommer JE, Martin JH, Scheiffele P (2007) α 2-Chimaerin is an essential EphA4 effector in the assembly of neuronal locomotor circuits. *Neuron* 55: 768-78.
- Benes CH, Wu N, Elia AE, Dharia T, Cantley LC, Soltoff SP (2005) The C2 domain of PKC δ is a phosphotyrosine binding domain. *Cell* 121: 271-80.
- Benowitz LI, Routtenberg A (1997) GAP-43: An intrinsic determinant of neuronal development and plasticity. *Trends Neurosci* 20: 84-91.

- Benzaria S, Bienfait B, Nacro K, Wang S, Lewin NE, Beheshti M, Blumberg PM, Marquez VE (1998) Conformationally constrained analogues of diacylglycerol (DAG). 15. The indispensable role of the *sn*-1 and *sn*-2 carbonyls in the binding of DAG-lactones to protein kinase C (PK-C). *Bioorg Med Chem Lett* 8: 3403-8.
- Bernstein BW, Bamburg JR (2010) ADF/cofilin: A functional node in cell biology. *Trends Cell Biol* 20: 187-95.
- Betz A, Ashery U, Rickmann M, Augustin I, Neher E, Südhof TC, Rettig J, Brose N (1998) Munc13-1 is a presynaptic phorbol ester receptor that enhances neurotransmitter release. *Neuron* 21: 123-36.
- Bittova L, Stahelin RV, Cho W (2001) Roles of ionic residues of the C1 domain in protein kinase C- α activation and the origin of phosphatidylserine specificity. *J Biol Chem* 276: 4218-26.
- Blumberg PM, Kedeei N, Lewin NE, Yang D, Czifra G, Pu Y, Peach ML, Marquez VE (2008) Wealth of opportunity - the C1 domain as a target for drug development. *Curr Drug Targets* 9: 641-52.
- Blume-Jensen P, Hunter T (2001) Oncogenic kinase signalling. *Nature* 411: 355-65.
- Boije af Gennäs G, Talman V, Yli-Kauhala J, Tuominen RK, Ekokoski E (2011) Current status and future prospects of C1 domain ligands as drug candidates. *Curr Top Med Chem* 11: 1370-92.
- Bradford MM (1976) A rapid and sensitive method for the quantitation of microgram quantities of protein utilizing the principle of protein-dye binding. *Anal Biochem* 72: 248-54.
- Bright R, Mochly-Rosen D (2005) The role of protein kinase C in cerebral ischemic and reperfusion injury. *Stroke* 36: 2781-90.
- Broeke JH, Roelandse M, Luteijn MJ, Boiko T, Matus A, Toonen RF, Verhage M (2010) Munc18 and Munc13 regulate early neurite outgrowth. *Biol Cell* 102: 479-88.
- Brose N, Betz A, Wegmeyer H (2004) Divergent and convergent signaling by the diacylglycerol second messenger pathway in mammals. *Curr Opin Neurobiol* 14: 328-40.
- Brose N, Hofmann K, Hata Y, Südhof TC (1995) Mammalian homologues of *Caenorhabditis elegans unc-13* gene define novel family of C2-domain proteins. *J Biol Chem* 270: 25273-80.
- Brose N, Rosenmund C, Rettig J (2000) Regulation of transmitter release by Unc-13 and its homologues. *Curr Opin Neurobiol* 10: 303-11.
- Buttery P, Beg AA, Chih B, Broder A, Mason CA, Scheiffele P (2006) The diacylglycerol-binding protein α 1-chimaerin regulates dendritic morphology. *Proc Natl Acad Sci U S A* 103: 1924-9.
- Bögi K, Lorenzo PS, Szállási Z, Acs P, Wagner GS, Blumberg PM (1998) Differential selectivity of ligands for the C1a and C1b phorbol ester binding domains of protein kinase C δ : Possible correlation with tumor-promoting activity. *Cancer Res* 58: 1423-8.
- Caloca MJ, Fernandez N, Lewin NE, Ching D, Modali R, Blumberg PM, Kazanietz MG (1997) β 2-Chimaerin is a high affinity receptor for the phorbol ester tumor promoters. *J Biol Chem* 272: 26488-96.
- Caloca MJ, Garcia-Bermejo ML, Blumberg PM, Lewin NE, Kremmer E, Mischak H, Wang S, Nacro K, Bienfait B, Marquez VE, Kazanietz MG (1999) β 2-Chimaerin is a novel target for diacylglycerol: Binding properties and changes in subcellular localization mediated by ligand binding to its C1 domain. *Proc Natl Acad Sci U S A* 96: 11854-9.
- Caloca MJ, Wang H, Delemos A, Wang S, Kazanietz MG (2001) Phorbol esters and related analogs regulate the subcellular localization of β 2-chimaerin, a non-protein kinase C phorbol ester receptor. *J Biol Chem* 276: 18303-12.
- Caloca MJ, Wang H, Kazanietz MG (2003) Characterization of the Rac-GAP (Rac-GTPase-activating protein) activity of β 2-chimaerin, a 'non-protein kinase C' phorbol ester receptor. *Biochem J* 375: 313-21.
- Cameron AJ, Parker PJ (2009) Protein kinase C - A family of protein kinases, allosteric effectors or both? *Adv Enzyme Regul* 50: 169-77.
- Cameron AJ, Procyk KJ, Leitges M, Parker PJ (2008) PKC α protein but not kinase activity is critical for glioma cell proliferation and survival. *Int J Cancer* 123: 769-79.
- Canagarajah B, Leskow FC, Ho JY, Mischak H, Saidi LF, Kazanietz MG, Hurley JH (2004) Structural mechanism for lipid activation of the Rac-specific GAP, β 2-chimaerin. *Cell* 119: 407-18.
- Caricasole A, Bettini E, Sala C, Roncarati R, Kobayashi N, Caldara F, Goto K, Terstappen GC (2002) Molecular cloning and characterization of the human diacylglycerol kinase β (DGK β) gene: Alternative splicing generates DGK β isoforms with different properties. *J Biol Chem* 277: 4790-6.

- Carrasco S, Merida I (2007) Diacylglycerol, when simplicity becomes complex. *Trends Biochem Sci* 32: 27-36.
- Castagna M, Takai Y, Kaibuchi K, Sano K, Kikkawa U, Nishizuka Y (1982) Direct activation of calcium-activated, phospholipid-dependent protein kinase by tumor-promoting phorbol esters. *J Biol Chem* 257: 7847-51.
- Chen D, Purohit A, Halilovic E, Doxsey SJ, Newton AC (2004) Centrosomal anchoring of protein kinase C β II by pericentrin controls microtubule organization, spindle function, and cytokinesis. *J Biol Chem* 279: 4829-39.
- Chen J, Deng F, Li J, Wang QJ (2008a) Selective binding of phorbol esters and diacylglycerol by individual C1 domains of the PKD family. *Biochem J* 411: 333-42.
- Chen J, Deng F, Singh SV, Wang QJ (2008b) Protein kinase D3 (PKD3) contributes to prostate cancer cell growth and survival through a PKC ϵ /PKD3 pathway downstream of Akt and ERK 1/2. *Cancer Res* 68: 3844-53.
- Chen L, Hahn H, Wu G, Chen CH, Liron T, Schechtman D, Cavallaro G, Banci L, Guo Y, Bolli R, Dorn GW 2nd, Mochly-Rosen D (2001) Opposing cardioprotective actions and parallel hypertrophic effects of δ PKC and ϵ PKC. *Proc Natl Acad Sci U S A* 98: 11114-9.
- Chen S, Borowiak M, Fox JL, Maehr R, Osafune K, Davidow L, Lam K, Peng LF, Schreiber SL, Rubin LL, Melton D (2009) A small molecule that directs differentiation of human ESCs into the pancreatic lineage. *Nat Chem Biol* 5: 258-65.
- Chen XQ, Tan I, Leung T, Lim L (1999) The myotonic dystrophy kinase-related Cdc42-binding kinase is involved in the regulation of neurite outgrowth in PC12 cells. *J Biol Chem* 274: 19901-5.
- Chiarini A, Whitfield JF, Pacchiana R, Marconi M, Armato U, Dal Prà I (2010) Calphostin C, a remarkable multimodal photodynamic killer of neoplastic cells by selective nuclear lamin B1 destruction and apoptosis. *Oncol Rep* 23: 887-92.
- Chida K, Hara T, Hirai T, Konishi C, Nakamura K, Nakao K, Aiba A, Katsuki M, Kuroki T (2003) Disruption of protein kinase C η results in impairment of wound healing and enhancement of tumor formation in mouse skin carcinogenesis. *Cancer Res* 63: 2404-8.
- Choi SH, Czifra G, Kedei N, Lewin NE, Lazar J, Pu Y, Marquez VE, Blumberg PM (2008) Characterization of the interaction of phorbol esters with the C1 domain of MRCK (myotonic dystrophy kinase-related Cdc42 binding kinase) α/β . *J Biol Chem* 283: 10543-9.
- Choi SH, Hyman T, Blumberg PM (2006) Differential effect of bryostatin 1 and phorbol 12-myristate 13-acetate on HOP-92 cell proliferation is mediated by down-regulation of protein kinase C δ . *Cancer Res* 66: 7261-9.
- Choi Y, Pu Y, Peach ML, Kang JH, Lewin NE, Sigano DM, Garfield SH, Blumberg PM, Marquez VE (2007) Conformationally constrained analogues of diacylglycerol (DAG). 28. DAG-dioxolanones reveal a new additional interaction site in the C1b domain of PKC δ . *J Med Chem* 50: 3465-81.
- Churchill E, Budas G, Vallentin A, Koyanagi T, Mochly-Rosen D (2008) PKC isozymes in chronic cardiac disease: Possible therapeutic targets? *Annu Rev Pharmacol Toxicol* 48: 569-99.
- Churchill EN, Qvit N, Mochly-Rosen D (2009) Rationally designed peptide regulators of protein kinase C. *Trends Endocrinol Metab* 20: 25-33.
- Clamp A, Jayson GC (2002) The clinical development of the bryostatins. *Anticancer Drugs* 13: 673-83.
- Coghlan MP, Chou MM, Carpenter CL (2000) Atypical protein kinases C λ and - ζ associate with the GTP-binding protein Cdc42 and mediate stress fiber loss. *Mol Cell Biol* 20: 2880-9.
- Colón-González F, Kazanietz MG (2006) C1 domains exposed: From diacylglycerol binding to protein-protein interactions. *Biochim Biophys Acta* 1761: 827-37.
- Comin MJ, Czifra G, Kedei N, Telek A, Lewin NE, Kolusheva S, Velasquez JF, Kobylarz R, Jelinek R, Blumberg PM, Marquez VE (2009) Conformationally constrained analogues of diacylglycerol (DAG). 31. Modulation of the biological properties of diacylglycerol lactones (DAG-lactones) containing rigid-rod acyl groups separated from the core lactone by spacer units of different lengths. *J Med Chem* 52: 3274-83.
- Corbalán-García S, García-García J, Rodríguez-Alfaro JA, Gómez-Fernández JC (2003a) A new phosphatidylinositol 4,5-bisphosphate-binding site located in the C2 domain of protein kinase C α . *J Biol Chem* 278: 4972-80.
- Corbalán-García S, Gómez-Fernández JC (2010) The C2 domains of classical and novel PKCs as versatile decoders of membrane signals. *Biofactors* 36: 1-7.
- Corbalán-García S, Sánchez-Carrillo S, García-García J, Gómez-Fernández JC (2003b) Characterization of the membrane binding mode of the C2 domain of PKC ϵ . *Biochemistry* 42: 11661-8.

- Coughlin JJ, Stang SL, Dower NA, Stone JC (2005) RasGRP1 and RasGRP3 regulate B cell proliferation by facilitating B cell receptor-Ras signaling. *J Immunol* 175: 7179-84.
- Coussens L, Parker PJ, Rhee L, Yang-Feng TL, Chen E, Waterfield MD, Francke U, Ullrich A (1986) Multiple, distinct forms of bovine and human protein kinase C suggest diversity in cellular signaling pathways. *Science* 233: 859-66.
- Coussens L, Rhee L, Parker PJ, Ullrich A (1987) Alternative splicing increases the diversity of the human protein kinase C family. *DNA* 6: 389-94.
- Datta R, Kojima H, Yoshida K, Kufe D (1997) Caspase-3-mediated cleavage of protein kinase C θ in induction of apoptosis. *J Biol Chem* 272: 20317-20.
- Daub H, Specht K, Ullrich A (2004) Strategies to overcome resistance to targeted protein kinase inhibitors. *Nat Rev Drug Discov* 3: 1001-10.
- Davidson SK, Allen SW, Lim GE, Anderson CM, Haygood MG (2001) Evidence for the biosynthesis of bryostatins by the bacterial symbiont "*Candidatus Endobugula sertula*" of the bryozoan *Bugula neritina*. *Appl Environ Microbiol* 67: 4531-7.
- Davies SP, Reddy H, Caivano M, Cohen P (2000) Specificity and mechanism of action of some commonly used protein kinase inhibitors. *Biochem J* 351: 95-105.
- Day ML, Zhao X, Wu S, Swanson PE, Humphrey PA (1994) Phorbol ester-induced apoptosis is accompanied by NGFI-A and *c-fos* activation in androgen-sensitive prostate cancer cells. *Cell Growth Differ* 5: 735-41.
- DeChristopher BA, Loy BA, Marsden MD, Schrier AJ, Zack JA, Wender PA (2012) Designed, synthetically accessible bryostatin analogues potently induce activation of latent HIV reservoirs *in vitro*. *Nat Chem* 4: 705-10.
- Dower NA, Stang SL, Bottorff DA, Ebinu JO, Dickie P, Ostergaard HL, Stone JC (2000) RasGRP is essential for mouse thymocyte differentiation and TCR signaling. *Nat Immunol* 1: 317-21.
- Dries DR, Gallegos LL, Newton AC (2007) A single residue in the C1 domain sensitizes novel protein kinase C isoforms to cellular diacylglycerol production. *J Biol Chem* 282: 826-30.
- Duan D, Sigano DM, Kelley JA, Lai CC, Lewin NE, Kedei N, Peach ML, Lee J, Abeyweera TP, Rotenberg SA, Kim H, Kim YH, Kazzouli SE, Chung JU, Young HA, Young MR, Baker A, Colburn NH, Haimovitz-Friedman A, Truman JP, Parrish DA, Deschamps JR, Perry NA, Surawski RJ, Blumberg PM, Marquez VE (2008) Conformationally constrained analogues of diacylglycerol. 29. Cells sort diacylglycerol-lactone chemical zip codes to produce diverse and selective biological activities. *J Med Chem* 51: 5198-220.
- Duff K, Planel E (2005) Untangling memory deficits. *Nat Med* 11: 826-7.
- Ebinu JO, Bottorff DA, Chan EY, Stang SL, Dunn RJ, Stone JC (1998) RasGRP, a Ras guanyl nucleotide-releasing protein with calcium- and diacylglycerol-binding motifs. *Science* 280: 1082-6.
- Ebinu JO, Stang SL, Teixeira C, Bottorff DA, Hooton J, Blumberg PM, Barry M, Bleakley RC, Ostergaard HL, Stone JC (2000) RasGRP links T-cell receptor signaling to Ras. *Blood* 95: 3199-203.
- Eden E, Navon R, Steinfeld I, Lipson D, Yakhini Z (2009) *GOrilla*: A tool for discovery and visualization of enriched GO terms in ranked gene lists. *BMC Bioinformatics* 10: 48.
- Eiseler T, Döppler H, Yan IK, Kitatani K, Mizuno K, Storz P (2009) Protein kinase D1 regulates cofilin-mediated F-actin reorganization and cell motility through slingshot. *Nat Cell Biol* 11: 545-56.
- Eiseler T, Hausser A, De Kimpe L, Van Lint J, Pfizenmaier K (2010) Protein kinase D controls actin polymerization and cell motility through phosphorylation of cortactin. *J Biol Chem* 285: 18672-83.
- El Kazzouli S, Lewin NE, Blumberg PM, Marquez VE (2008) Conformationally constrained analogues of diacylglycerol. 30. An investigation of diacylglycerol-lactones containing heteroaryl groups reveals compounds with high selectivity for Ras guanyl nucleotide-releasing proteins. *J Med Chem* 51: 5371-86.
- EMA (2012) Picato. Updated on November 29, 2012. Accessed July 10, 2013 via the Internet at www.ema.europa.eu.
- Emoto Y, Manome Y, Meinhardt G, Kisaki H, Kharbanda S, Robertson M, Ghayur T, Wong WW, Kamen R, Weichselbaum R (1995) Proteolytic activation of protein kinase C δ by an ICE-like protease in apoptotic cells. *EMBO J* 14: 6148-56.

- Endo K, Oki E, Biedermann V, Kojima H, Yoshida K, Johannes FJ, Kufe D, Datta R (2000) Proteolytic cleavage and activation of protein kinase C μ by caspase-3 in the apoptotic response of cells to 1- β -D-arabinofuranosylcytosine and other genotoxic agents. *J Biol Chem* 275: 18476-81.
- Endo Y, Ohno M, Hirano M, Itai A, Shudo K (1996) Synthesis, conformation, and biological activity of teleocidin mimics, benzolactams. A clarification of the conformational flexibility problem in structure-activity studies of teleocidins. *J Am Chem Soc* 118: 1841-55.
- Endo Y, Takehana S, Ohno M, Driedger PE, Stabel S, Mizutani MY, Tomioka N, Itai A, Shudo K (1998) Clarification of the binding mode of teleocidin and benzolactams to the Cys2 domain of protein kinase C δ by synthesis of hydrophobically modified, teleocidin-mimicking benzolactams and computational docking simulation. *J Med Chem* 41: 1476-96.
- Etcheberrigaray R, Tan M, Dewachter I, Kuiperi C, Van der Auwera I, Wera S, Qiao L, Bank B, Nelson TJ, Kozikowski AP, Van Leuven F, Alkon DL (2004) Therapeutic effects of PKC activators in Alzheimer's disease transgenic mice. *Proc Natl Acad Sci U S A* 101: 11141-6.
- Etienne-Manneville S, Hall A (2002) Rho GTPases in cell biology. *Nature* 420: 629-35.
- FDA (2012) FDA approved drug products: Picato. Updated on January 23, 2012. Accessed July 10, 2013 via the Internet at <http://www.fda.gov/Drugs/default.htm>.
- Ferlay J, Shin HR, Bray F, Forman D, Mathers C, Parkin DM (2010) GLOBOCAN 2008 v2.0, cancer incidence and mortality worldwide: IARC CancerBase no. 10. 2013. Accessed July 9, 2013 via the Internet at <http://globocan.iarc.fr>.
- Ferrario JE, Baskaran P, Clark C, Hendry A, Lerner O, Hintze M, Allen J, Chilton JK, Guthrie S (2012) Axon guidance in the developing ocular motor system and duane retraction syndrome depends on semaphorin signaling via α 2-chimaerin. *Proc Natl Acad Sci U S A* 109: 14669-74.
- Ferreira JC, Brum PC, Mochly-Rosen D (2011) β IIPKC and ϵ PKC isozymes as potential pharmacological targets in cardiac hypertrophy and heart failure. *J Mol Cell Cardiol* 51: 479-84.
- Fielitz J, Kim MS, Shelton JM, Qi X, Hill JA, Richardson JA, Bassel-Duby R, Olson EN (2008) Requirement of protein kinase D1 for pathological cardiac remodeling. *Proc Natl Acad Sci U S A* 105: 3059-63.
- Finnish Cancer Registry (2013) Cancer statistics 2011. Updated on June 6, 2013. Accessed July 9, 2013 via the Internet at <http://www.cancerregistry.fi>.
- Fu Y, Rubin CS (2011) Protein kinase D: Coupling extracellular stimuli to the regulation of cell physiology. *EMBO Rep* 12: 785-96.
- Galkin A, Surakka A, Boije af Gennäs G, Ruotsalainen T, Kreander K, Tammela P, Sivonen K, Yli-Kauhaluoma J, Vuorela P (2008) Hydrophobic derivatives of 5-(hydroxymethyl)isophthalic acid that selectively induce apoptosis in leukemia cells but not in fibroblasts. *Drug Dev Res* 69: 185-95.
- Gao T, Brognard J, Newton AC (2008) The phosphatase PHLPP controls the cellular levels of protein kinase C. *J Biol Chem* 283: 6300-11.
- Garcia-Bermejo ML, Leskow FC, Fujii T, Wang Q, Blumberg PM, Ohba M, Kuroki T, Han KC, Lee J, Marquez VE, Kazanietz MG (2002) Diacylglycerol (DAG)-lactones, a new class of protein kinase C (PKC) agonists, induce apoptosis in LNCaP prostate cancer cells by selective activation of PKC α . *J Biol Chem* 277: 645-55.
- Garrido JL, Godoy JA, Alvarez A, Bronfman M, Inestrosa NC (2002) Protein kinase C inhibits amyloid β -peptide neurotoxicity by acting on members of the Wnt pathway. *FASEB J* 16: 1982-4.
- Geraldes P, King GL (2010) Activation of protein kinase C isoforms and its impact on diabetic complications. *Circ Res* 106: 1319-31.
- Gillespie SK, Zhang XD, Hersey P (2004) Ingenol 3-angelate induces dual modes of cell death and differentially regulates tumor necrosis factor-related apoptosis-inducing ligand-induced apoptosis in melanoma cells. *Mol Cancer Ther* 3: 1651-8.
- Giorgione JR, Lin JH, McCammon JA, Newton AC (2006) Increased membrane affinity of the C1 domain of protein kinase C δ compensates for the lack of involvement of its C2 domain in membrane recruitment. *J Biol Chem* 281: 1660-9.
- Goel G, Makkar HP, Francis G, Becker K (2007) Phorbol esters: Structure, biological activity, and toxicity in animals. *Int J Toxicol* 26: 279-88.

- Gomes ER, Jani S, Gundersen GG (2005) Nuclear movement regulated by Cdc42, MRCK, myosin, and actin flow establishes MTOC polarization in migrating cells. *Cell* 121: 451-63.
- Gopalakrishna R, Chen ZH, Gundimeda U (1992a) Irreversible oxidative inactivation of protein kinase C by photosensitive inhibitor calphostin C. *FEBS Lett* 314: 149-54.
- Gopalakrishna R, Chen ZH, Gundimeda U, Wilson JC, Anderson WB (1992b) Rapid filtration assays for protein kinase C activity and phorbol ester binding using multiwell plates with fitted filtration discs. *Anal Biochem* 206: 24-35.
- Gopalakrishna R, Jaken S (2000) Protein kinase C signaling and oxidative stress. *Free Radic Biol Med* 28: 1349-61.
- Gorin MA, Pan Q (2009) Protein kinase C ϵ : An oncogene and emerging tumor biomarker. *Mol Cancer* 8: 9.
- Govoni S, Amadio M, Battaini F, Pascale A (2010) Senescence of the brain: Focus on cognitive kinases. *Curr Pharm Des* 16: 660-71.
- Griffiths M, Sundaram H (2011) Drug design and testing: Profiling of antiproliferative agents for cancer therapy using a cell-based methyl- ^3H -thymidine incorporation assay. *Methods Mol Biol* 731: 451-65.
- Griner EM, Caino MC, Sosa MS, Colón-González F, Chalmers MJ, Mischak H, Kazanietz MG (2010) A novel cross-talk in diacylglycerol signaling: The Rac-GAP β 2-chimaerin is negatively regulated by protein kinase C δ -mediated phosphorylation. *J Biol Chem* 285: 16931-41.
- Griner EM, Kazanietz MG (2007) Protein kinase C and other diacylglycerol effectors in cancer. *Nat Rev Cancer* 7: 281-94.
- Grodsky N, Li Y, Bouzida D, Love R, Jensen J, Nodes B, Nonomiya J, Grant S (2006) Structure of the catalytic domain of human protein kinase C β II complexed with a bisindolylmaleimide inhibitor. *Biochemistry* 45: 13970-81.
- Groeger G, Nobes CD (2007) Co-operative Cdc42 and Rho signalling mediates ephrinB-triggered endothelial cell retraction. *Biochem J* 404: 23-9.
- Guha S, Tanasanvimon S, Sinnott-Smith J, Rozengurt E (2010) Role of protein kinase D signaling in pancreatic cancer. *Biochem Pharmacol* 80: 1946-54.
- Guo J, Gertsberg Z, Ozgen N, Sabri A, Steinberg SF (2011) Protein kinase D isoforms are activated in an agonist-specific manner in cardiomyocytes. *J Biol Chem* 286: 6500-9.
- Hampson P, Chahal H, Khanim F, Hayden R, Mulder A, Assi LK, Bunce CM, Lord JM (2005) PEP005, a selective small-molecule activator of protein kinase C, has potent antileukemic activity mediated via the delta isoform of PKC. *Blood* 106: 1362-8.
- Hampson P, Wang K, Milverton L, Ersvaer E, Bruserud O, Lord JM (2010) Kinetics of ERK1/2 activation determine sensitivity of acute myeloid leukaemia cells to the induction of apoptosis by the novel small molecule ingenol 3-angelate (PEP005). *Apoptosis* 15: 946-55.
- Han ZT, Zhu XX, Yang RY, Sun JZ, Tian GF, Liu XJ, Cao GS, Newmark HL, Conney AH, Chang RL (1998) Effect of intravenous infusions of 12-O-tetradecanoylphorbol-13-acetate (TPA) in patients with myelocytic leukemia: Preliminary studies on therapeutic efficacy and toxicity. *Proc Natl Acad Sci U S A* 95: 5357-61.
- Hara T, Saito Y, Hirai T, Nakamura K, Nakao K, Katsuki M, Chida K (2005) Deficiency of protein kinase C α in mice results in impairment of epidermal hyperplasia and enhancement of tumor formation in two-stage skin carcinogenesis. *Cancer Res* 65: 7356-62.
- Hardy JA, Higgins GA (1992) Alzheimer's disease: The amyloid cascade hypothesis. *Science* 256: 184-5.
- Harikumar KB, Kunnumakkara AB, Ochi N, Tong Z, Deorukhkar A, Sung B, Kelland L, Jamieson S, Sutherland R, Raynham T, Charles M, Bagherzadeh A, Foxton C, Boakes A, Farooq M, Maru D, Diagaradjane P, Matsuo Y, Sinnott-Smith J, Gelovani J, Krishnan S, Aggarwal BB, Rozengurt E, Ireson CR, Guha S (2010) A novel small-molecule inhibitor of protein kinase D blocks pancreatic cancer growth *in vitro* and *in vivo*. *Mol Cancer Ther* 9: 1136-46.
- Harstrick A, Vanhoefer U, Schleucher N, Schroeder J, Baumgart J, Scheulen ME, Wilke H, Seeber S (1995) Activity of *N*-benzyl-adriamycin-14-valerate (AD198), a new anthracycline derivate, in multidrug resistant human ovarian and breast carcinoma cell lines. *Anticancer Drugs* 6: 681-5.
- Hartlage-Rübsamen M, Waniek A, Rossner S (2013) Munc13 genotype regulates secretory amyloid precursor protein processing via postsynaptic glutamate receptors. *Int J Dev Neurosci* 31: 36-45.

- He Y, Liu J, Durrant D, Yang HS, Sweatman T, Lothstein L, Lee RM (2005) *N*-benzyladriamycin-14-valerate (AD198) induces apoptosis through protein kinase C- δ -induced phosphorylation of phospholipid scramblase 3. *Cancer Res* 65: 10016-23.
- Heikkilä T, Wheatley E, Crighton D, Schroder E, Boakes A, Kaye SJ, Mezna M, Pang L, Rushbrooke M, Turnbull A, Olson MF (2011) Co-crystal structures of inhibitors with MRCK β , a key regulator of tumor cell invasion. *PLoS One* 6: e24825.
- Hennings H, Blumberg PM, Pettit GR, Herald CL, Shores R, Yuspa SH (1987) Bryostatin 1, an activator of protein kinase C, inhibits tumor promotion by phorbol esters in SENCAR mouse skin. *Carcinogenesis* 8: 1343-6.
- Heudorf U, Mersch-Sundermann V, Angerer J (2007) Phthalates: Toxicology and exposure. *Int J Hyg Environ Health* 210: 623-34.
- Hodge CW, Mehmert KK, Kelley SP, McMahan T, Haywood A, Olive MF, Wang D, Sanchez-Perez AM, Messing RO (1999) Supersensitivity to allosteric GABA_A receptor modulators and alcohol in mice lacking PKC ϵ . *Nat Neurosci* 2: 997-1002.
- Hofmann J (2004) Protein kinase C isozymes as potential targets for anticancer therapy. *Curr Cancer Drug Targets* 4: 125-46.
- Hofmann PA, Israel M, Koseki Y, Laskin J, Gray J, Janik A, Sweatman TW, Lothstein L (2007) *N*-benzyladriamycin-14-valerate (AD 198): A non-cardiotoxic anthracycline that is cardioprotective through PKC- ϵ activation. *J Pharmacol Exp Ther* 323: 658-64.
- Hokin MR, Hokin LE (1953) Enzyme secretion and the incorporation of P³² into phospholipides of pancreas slices. *J Biol Chem* 203: 967-77.
- Holahan M, Routtenberg A (2008) The protein kinase C phosphorylation site on GAP-43 differentially regulates information storage. *Hippocampus* 18: 1099-102.
- Hommel U, Zurini M, Luyten M (1994) Solution structure of a cysteine rich domain of rat protein kinase C. *Nat Struct Biol* 1: 383-7.
- Hooper C, Killick R, Lovestone S (2008) The GSK3 hypothesis of Alzheimer's disease. *J Neurochem* 104: 1433-9.
- Hotulainen P, Paunola E, Vartiainen MK, Lappalainen P (2005) Actin-depolymerizing factor and cofilin-1 play overlapping roles in promoting rapid F-actin depolymerization in mammalian nonmuscle cells. *Mol Biol Cell* 16: 649-64.
- House C, Kemp BE (1987) Protein kinase C contains a pseudosubstrate prototope in its regulatory domain. *Science* 238: 1726-8.
- Hozumi Y, Watanabe M, Otani K, Goto K (2009) Diacylglycerol kinase β promotes dendritic outgrowth and spine maturation in developing hippocampal neurons. *BMC Neurosci* 10: 99.
- Hurley JH, Newton AC, Parker PJ, Blumberg PM, Nishizuka Y (1997) Taxonomy and function of C1 protein kinase C homology domains. *Protein Sci* 6: 477-80.
- Huwiler A, Fabbro D, Pfeilschifter J (1998) Selective ceramide binding to protein kinase C- α and - δ isoenzymes in renal mesangial cells. *Biochemistry* 37: 14556-62.
- Ibarreta D, Duchon M, Ma D, Qiao L, Kozikowski AP, Etcheberrigaray R (1999) Benzolactam (BL) enhances sAPP secretion in fibroblasts and in PC12 cells. *Neuroreport* 10: 1035-40.
- Iglesias T, Matthews S, Rozengurt E (1998) Dissimilar phorbol ester binding properties of the individual cysteine-rich motifs of protein kinase D. *FEBS Lett* 437: 19-23.
- Iglesias T, Rozengurt E (1998) Protein kinase D activation by mutations within its pleckstrin homology domain. *J Biol Chem* 273: 410-6.
- Iglesias T, Rozengurt E (1999) Protein kinase D activation by deletion of its cysteine-rich motifs. *FEBS Lett* 454: 53-6.
- Inagaki K, Churchill E, Mochly-Rosen D (2006) Epsilon protein kinase C as a potential therapeutic target for the ischemic heart. *Cardiovasc Res* 70: 222-30.
- Inoue M, Kishimoto A, Takai Y, Nishizuka Y (1977) Studies on a cyclic nucleotide-independent protein kinase and its proenzyme in mammalian tissues. II. Proenzyme and its activation by calcium-dependent protease from rat brain. *J Biol Chem* 252: 7610-6.
- Ip JP, Shi L, Chen Y, Itoh Y, Fu WY, Betz A, Yung WH, Gotoh Y, Fu AK, Ip NY (2011) α 2-Chimaerin controls neuronal migration and functioning of the cerebral cortex through CRMP-2. *Nat Neurosci* 15: 39-47.

- Irie K, Masuda A, Shindo M, Nakagawa Y, Ohigashi H (2004) Tumor promoter binding of the protein kinase C C1 homology domain peptides of RasGRPs, chimaerins, and Unc13s. *Bioorg Med Chem* 12: 4575-83.
- Irie K, Nakagawa Y, Ohigashi H (2005) Toward the development of new medicinal leads with selectivity for protein kinase C isozymes. *Chem Rec* 5: 185-95.
- Irie K, Oie K, Nakahara A, Yanai Y, Ohigashi H, Wender PA, Fukuda H, Konishi H, Kikkawa U (1998) Molecular basis for protein kinase C isozyme-selective binding: The synthesis, folding, and phorbol ester binding of the cysteine-rich domains of all protein kinase C isozymes. *J Am Chem Soc* 120: 9159-67.
- Isagawa T, Mukai H, Oishi K, Taniguchi T, Hasegawa H, Kawamata T, Tanaka C, Ono Y (2000) Dual effects of PKN α and protein kinase C on phosphorylation of tau protein by glycogen synthase kinase-3 β . *Biochem Biophys Res Commun* 273: 209-12.
- Jackson DN, Foster DA (2004) The enigmatic protein kinase C δ : Complex roles in cell proliferation and survival. *FASEB J* 18: 627-36.
- Jacob AI, Horovitz-Fried M, Aga-Mizrachi S, Brutman-Barazani T, Okhrimenko H, Zick Y, Brodie C, Sampson SR (2010) The regulatory domain of protein kinase C delta positively regulates insulin receptor signaling. *J Mol Endocrinol* 44: 155-69.
- Jacobsen JS, Spruyt MA, Brown AM, Sahasrabudhe SR, Blume AJ, Vitek MP, Muenkel HA, Sonnenberg-Reines J (1994) The release of Alzheimer's disease β amyloid peptide is reduced by phorbol treatment. *J Biol Chem* 269: 8376-82.
- Johnson JE, Goulding RE, Ding Z, Partovi A, Anthony KV, Beaulieu N, Tazmini G, Cornell RB, Kay RJ (2007) Differential membrane binding and diacylglycerol recognition by C1 domains of RasGRPs. *Biochem J* 406: 223-36.
- Jones HW Jr (1997) Record of the first physician to see Henrietta Lacks at the Johns Hopkins Hospital: History of the beginning of the HeLa cell line. *Am J Obstet Gynecol* 176: S227-8.
- Junge HJ, Rhee JS, Jahn O, Varoqueaux F, Spiess J, Waxham MN, Rosenmund C, Brose N (2004) Calmodulin and Munc13 form a Ca²⁺ sensor/effector complex that controls short-term synaptic plasticity. *Cell* 118: 389-401.
- Kakefuda K, Oyagi A, Ishisaka M, Tsuruma K, Shimazawa M, Yokota K, Shirai Y, Horie K, Saito N, Takeda J, Hara H (2010) Diacylglycerol kinase β knockout mice exhibit lithium-sensitive behavioral abnormalities. *PLoS One* 5: e13447.
- Kang JH, Kim Y, Won SH, Park SK, Lee CW, Kim HM, Lewin NE, Perry NA, Pearce LV, Lundberg DJ, Surawski RJ, Blumberg PM, Lee J (2010) Polar 3-alkylidene-5-pivaloyloxymethyl-5'-hydroxymethyl- γ -lactones as protein kinase C ligands and antitumor agents. *Bioorg Med Chem Lett* 20: 1008-12.
- Kang L, He Z, Xu P, Fan J, Betz A, Brose N, Xu T (2006) Munc13-1 is required for the sustained release of insulin from pancreatic β cells. *Cell Metab* 3: 463-8.
- Karaman MW, Herrgard S, Treiber DK, Gallant P, Atteridge CE, Campbell BT, Chan KW, Ciceri P, Davis MI, Edeen PT, Faraoni R, Floyd M, Hunt JP, Lockhart DJ, Milanov ZV, Morrison MJ, Pallares G, Patel HK, Pritchard S, Wodicka LM, Zarrinkar PP (2008) A quantitative analysis of kinase inhibitor selectivity. *Nat Biotechnol* 26: 127-32.
- Kashiwagi K, Shirai Y, Kuriyama M, Sakai N, Saito N (2002) Importance of C1B domain for lipid messenger-induced targeting of protein kinase C. *J Biol Chem* 277: 18037-45.
- Kawahara Y, Takai Y, Minakuchi R, Sano K, Nishizuka Y (1980) Phospholipid turnover as a possible transmembrane signal for protein phosphorylation during human platelet activation by thrombin. *Biochem Biophys Res Commun* 97: 309-17.
- Kazanietz MG, Areces LB, Bahador A, Mischak H, Goodnight J, Mushinski JF, Blumberg PM (1993) Characterization of ligand and substrate specificity for the calcium-dependent and calcium-independent protein kinase C isozymes. *Mol Pharmacol* 44: 298-307.
- Kazanietz MG, Krausz KW, Blumberg PM (1992) Differential irreversible insertion of protein kinase C into phospholipid vesicles by phorbol esters and related activators. *J Biol Chem* 267: 20878-86.
- Kazanietz MG, Lewin NE, Bruns JD, Blumberg PM (1995) Characterization of the cysteine-rich region of the *Caenorhabditis elegans* protein unc-13 as a high affinity phorbol ester receptor. Analysis of ligand-binding interactions, lipid cofactor requirements, and inhibitor sensitivity. *J Biol Chem* 270: 10777-83.
- Kazanietz MG, Lewin NE, Gao F, Pettit GR, Blumberg PM (1994) Binding of [26-³H]bryostatin 1 and analogs to calcium-dependent and calcium-independent protein kinase C isozymes. *Mol Pharmacol* 46: 374-9.

- Kedei N, Lundberg DJ, Toth A, Welburn P, Garfield SH, Blumberg PM (2004) Characterization of the interaction of ingenol 3-angelate with protein kinase C. *Cancer Res* 64: 3243-55.
- Keshamouni VG, Mattingly RR, Reddy KB (2002) Mechanism of 17- β -estradiol-induced Erk1/2 activation in breast cancer cells. A role for HER2 AND PKC- δ . *J Biol Chem* 277: 22558-65.
- Khasar SG, Lin YH, Martin A, Dadgar J, McMahon T, Wang D, Hundle B, Aley KO, Isenberg W, McCarter G, Green PG, Hodge CW, Levine JD, Messing RO (1999) A novel nociceptor signaling pathway revealed in protein kinase C ϵ mutant mice. *Neuron* 24: 253-60.
- Kim H, Yoon SC, Lee TY, Jeong D (2009) Discriminative cytotoxicity assessment based on various cellular damages. *Toxicol Lett* 184: 13-7.
- Kim R, Trubetsky A, Suzuki T, Jenkins NA, Copeland NG, Lenz J (2003) Genome-based identification of cancer genes by proviral tagging in mouse retrovirus-induced T-cell lymphomas. *J Virol* 77: 2056-62.
- Kim T, Hinton DJ, Choi DS (2011) Protein kinase C-regulated A β production and clearance. *Int J Alzheimers Dis* 2011: 857368.
- Kirwan AF, Bibby AC, Mvilongo T, Riedel H, Burke T, Millis SZ, Parissenti AM (2003) Inhibition of protein kinase C catalytic activity by additional regions within the human protein kinase C α -regulatory domain lying outside of the pseudosubstrate sequence. *Biochem J* 373: 571-81.
- Kishimoto A, Takai Y, Mori T, Kikkawa U, Nishizuka Y (1980) Activation of calcium and phospholipid-dependent protein kinase by diacylglycerol, its possible relation to phosphatidylinositol turnover. *J Biol Chem* 255: 2273-6.
- Kitazawa M, Yamasaki TR, LaFerla FM (2004) Microglia as a potential bridge between the amyloid β -peptide and tau. *Ann N Y Acad Sci* 1035: 85-103.
- Klinger MB, Guilbault B, Goulding RE, Kay RJ (2005) Deregulated expression of RasGRP1 initiates thymic lymphomagenesis independently of T-cell receptors. *Oncogene* 24: 2695-704.
- Kobayashi N, Hozumi Y, Ito T, Hosoya T, Kondo H, Goto K (2007) Differential subcellular targeting and activity-dependent subcellular localization of diacylglycerol kinase isozymes in transfected cells. *Eur J Cell Biol* 86: 433-44.
- Koch H, Hofmann K, Brose N (2000) Definition of Munc13-homology-domains and characterization of a novel ubiquitously expressed Munc13 isoform. *Biochem J* 349: 247-53.
- Kolch W, Heidecker G, Kochs G, Hummel R, Vahidi H, Mischak H, Finkenzeller G, Marmé D, Rapp UR (1993) Protein kinase C α activates RAF-1 by direct phosphorylation. *Nature* 364: 249-52.
- Konopatskaya O, Poole AW (2010) Protein kinase C α : Disease regulator and therapeutic target. *Trends Pharmacol Sci* 31: 8-14.
- Kozikowski AP, Wang S, Ma D, Yao J, Ahmad S, Glazer RI, Bögi K, Acs P, Modarres S, Lewin NE, Blumberg PM (1997) Modeling, chemistry, and biology of the benzolactam analogues of indolactam V (ILV). 2. Identification of the binding site of the benzolactams in the CRD2 activator-binding domain of PKC δ and discovery of an ILV analogue of improved isozyme selectivity. *J Med Chem* 40: 1316-26.
- Kraft AS, Smith JB, Berkow RL (1986) Bryostatin, an activator of the calcium phospholipid-dependent protein kinase, blocks phorbol ester-induced differentiation of human promyelocytic leukemia cells HL-60. *Proc Natl Acad Sci U S A* 83: 1334-8.
- Kulkosky J, Culnan DM, Roman J, Dornadula G, Schnell M, Boyd MR, Pomerantz RJ (2001) Prostratin: Activation of latent HIV-1 expression suggests a potential inductive adjuvant therapy for HAART. *Blood* 98: 3006-15.
- Larsson C (2006) Protein kinase C and the regulation of the actin cytoskeleton. *Cell Signal* 18: 276-84.
- Lavalle CR, George KM, Sharlow ER, Lazo JS, Wipf P, Wang QJ (2010) Protein kinase D as a potential new target for cancer therapy. *Biochim Biophys Acta* 1806: 183-92.
- Lee HW, Smith L, Pettit GR, Bingham Smith J (1996a) Dephosphorylation of activated protein kinase C contributes to downregulation by bryostatin. *Am J Physiol* 271: C304-11.
- Lee HW, Smith L, Pettit GR, Vinitzky A, Smith JB (1996b) Ubiquitination of protein kinase C- α and degradation by the proteasome. *J Biol Chem* 271: 20973-6.
- Lee J, Kang JH, Han KC, Kim Y, Kim SY, Youn HS, Mook-Jung I, Kim H, Lo Han JH, Ha HJ, Kim YH, Marquez VE, Lewin NE, Pearce LV, Lundberg DJ, Blumberg PM (2006) Branched diacylglycerol-lactones as potent protein kinase C ligands and α -secretase activators. *J Med Chem* 49: 2028-36.

- Lee SH, Yun S, Lee J, Kim MJ, Piao ZH, Jeong M, Chung JW, Kim TD, Yoon SR, Greenberg PD, Choi I (2009) RasGRP1 is required for human NK cell function. *J Immunol* 183: 7931-8.
- Lee SK, Qing WG, Mar W, Luyengi L, Mehta RG, Kawanishi K, Fong HH, Beecher CW, Kinghorn AD, Pezzuto JM (1998) Angoline and chelerythrine, benzophenanthridine alkaloids that do not inhibit protein kinase C. *J Biol Chem* 273: 19829-33.
- Lee WY, Hampson P, Coulthard L, Ali F, Salmon M, Lord JM, Scheel-Toellner D (2010) Novel antileukemic compound ingenol 3-angelate inhibits T cell apoptosis by activating protein kinase C θ . *J Biol Chem* 285: 23889-98.
- Lefort K, Mandinova A, Ostano P, Kolev V, Calpini V, Kolfshoten I, Devgan V, Lieb J, Raffoul W, Hohl D, Neel V, Garlick J, Chiorino G, Dotto GP (2007) Notch1 is a p53 target gene involved in human keratinocyte tumor suppression through negative regulation of ROCK1/2 and MRCK α kinases. *Genes Dev* 21: 562-77.
- Lehel C, Oláh Z, Jakab G, Szállási Z, Petrovics G, Harta G, Blumberg PM, Anderson WB (1995) Protein kinase C ϵ subcellular localization domains and proteolytic degradation sites. A model for protein kinase C conformational changes. *J Biol Chem* 270: 19651-8.
- Leitges M, Plomann M, Standaert ML, Bandyopadhyay G, Sajan MP, Kanoh Y, Farese RV (2002) Knockout of PKC α enhances insulin signaling through PI3K. *Mol Endocrinol* 16: 847-58.
- Leitges M, Schmedt C, Guinamard R, Davoust J, Schaal S, Stabel S, Tarakhovsky A (1996) Immunodeficiency in protein kinase C β -deficient mice. *Science* 273: 788-91.
- Leonard TA, Rozycki B, Saidi LF, Hummer G, Hurley JH (2011) Crystal structure and allosteric activation of protein kinase C β II. *Cell* 144: 55-66.
- Leontieva OV, Black JD (2004) Identification of two distinct pathways of protein kinase C α down-regulation in intestinal epithelial cells. *J Biol Chem* 279: 5788-801.
- Leung T, Chen XQ, Tan I, Manser E, Lim L (1998) Myotonic dystrophy kinase-related Cdc42-binding kinase acts as a Cdc42 effector in promoting cytoskeletal reorganization. *Mol Cell Biol* 18: 130-40.
- Lewin NE, Blumberg PM (2003) [3 H]phorbol 12,13-dibutyrate binding assay for protein kinase C and related proteins. *Methods Mol Biol* 233: 129-56.
- Li C, Li J, Cai X, Sun H, Jiao J, Bai T, Zhou XW, Chen X, Gill DL, Tang XD (2011) Protein kinase D3 is a pivotal activator of pathological cardiac hypertrophy by selectively increasing the expression of hypertrophic transcription factors. *J Biol Chem* 286: 40782-91.
- Li L, Yang Y, Stevens RL (2003) RasGRP4 regulates the expression of prostaglandin D2 in human and rat mast cell lines. *J Biol Chem* 278: 4725-9.
- Li W, Ma C, Guan R, Xu Y, Tomchick DR, Rizo J (2011) The crystal structure of a Munc13 C-terminal module exhibits a remarkable similarity to vesicle tethering factors. *Structure* 19: 1443-55.
- Liljedahl M, Maeda Y, Colanzi A, Ayala I, Van Lint J, Malhotra V (2001) Protein kinase D regulates the fission of cell surface destined transport carriers from the trans-Golgi network. *Cell* 104: 409-20.
- Ling M, Sunesson L, Larsson C (2007) Comparison of the PKC α and the PKC ϵ C1b domains: Identification of residues critical for PKC ϵ -mediated neurite induction. *J Mol Biol* 368: 951-65.
- Ling M, Trollér U, Zeidman R, Lundberg C, Larsson C (2004) Induction of neurites by the regulatory domains of PKC δ and ϵ is counteracted by PKC catalytic activity and by the RhoA pathway. *Exp Cell Res* 292: 135-50.
- López-Bergami P, Habelhah H, Bhoomik A, Zhang W, Wang LH, Ronai Z (2005) RACK1 mediates activation of JNK by protein kinase C. *Mol Cell* 19: 309-20.
- Lorenzo PS, Beheshti M, Pettit GR, Stone JC, Blumberg PM (2000) The guanine nucleotide exchange factor RasGRP is a high -affinity target for diacylglycerol and phorbol esters. *Mol Pharmacol* 57: 840-6.
- Lothstein L, Savranskaya L, Sweatman TW (2007) *N*-benzyladriamycin-14-valerate (AD 198) cytotoxicity circumvents Bcr-Abl anti-apoptotic signaling in human leukemia cells and also potentiates imatinib cytotoxicity. *Leuk Res* 31: 1085-95.
- Lou X, Korogod N, Brose N, Schneggenburger R (2008) Phorbol esters modulate spontaneous and Ca $^{2+}$ -evoked transmitter release via acting on both Munc13 and protein kinase C. *J Neurosci* 28: 8257-67.
- Lu Z, Hornia A, Jiang YW, Zang Q, Ohno S, Foster DA (1997) Tumor promotion by depleting cells of protein kinase C δ . *Mol Cell Biol* 17: 3418-28.

- Ma C, Li W, Xu Y, Rizo J (2011) Munc13 mediates the transition from the closed syntaxin-Munc18 complex to the SNARE complex. *Nat Struct Mol Biol* 18: 542-9.
- Mackay HJ, Twelves CJ (2007) Targeting the protein kinase C family: Are we there yet? *Nat Rev Cancer* 7: 554-62.
- MacKeigan JP, Murphy LO, Blenis J (2005) Sensitized RNAi screen of human kinases and phosphatases identifies new regulators of apoptosis and chemoresistance. *Nat Cell Biol* 7: 591-600.
- Macville M, Schrock E, Padilla-Nash H, Keck C, Ghadimi BM, Zimonjic D, Popescu N, Ried T (1999) Comprehensive and definitive molecular cytogenetic characterization of HeLa cells by spectral karyotyping. *Cancer Res* 59: 141-50.
- Maeda M, Kato S, Fukushima S, Kaneyuki U, Fujii T, Kazanietz MG, Oshima K, Shigemori M (2006) Regulation of vascular smooth muscle proliferation and migration by β 2-chimaerin, a non-protein kinase C phorbol ester receptor. *Int J Mol Med* 17: 559-66.
- Mamidi N, Gorai S, Mukherjee R, Manna D (2012a) Development of diacyltetrol lipids as activators for the C1 domain of protein kinase C. *Mol Biosyst* 8: 1275-85.
- Mamidi N, Gorai S, Sahoo J, Manna D (2012b) Alkyl cinnamates as regulator for the C1 domain of protein kinase C isoforms. *Chem Phys Lipids* 165: 320-30.
- Mann DM, Yates PO, Marcyniuk B (1986) A comparison of nerve cell loss in cortical and subcortical structures in Alzheimer's disease. *J Neurol Neurosurg Psychiatry* 49: 310-2.
- Manning G, Whyte DB, Martinez R, Hunter T, Sudarsanam S (2002) The protein kinase complement of the human genome. *Science* 298: 1912-34.
- Marland JR, Pan D, Buttery PC (2011) Rac GTPase-activating protein (Rac GAP) α 1-chimaerin undergoes proteasomal degradation and is stabilized by diacylglycerol signaling in neurons. *J Biol Chem* 286: 199-207.
- Marquez VE, Blumberg PM (2003) Synthetic diacylglycerols (DAG) and DAG-lactones as activators of protein kinase C (PK-C). *Acc Chem Res* 36: 434-43.
- Martin G, Swanson N (2013) Clinical findings using ingenol mebutate gel to treat actinic keratoses. *J Am Acad Dermatol* 68: S39-48.
- Martin TW (1988) Formation of diacylglycerol by a phospholipase D-phosphatidate phosphatase pathway specific for phosphatidylcholine in endothelial cells. *Biochim Biophys Acta* 962: 282-96.
- Matsubara T, Shirai Y, Miyasaka K, Murakami T, Yamaguchi Y, Ueyama T, Kai M, Sakane F, Kanoh H, Hashimoto T, Kamada S, Kikkawa U, Saito N (2006) Nuclear transportation of diacylglycerol kinase γ and its possible function in the nucleus. *J Biol Chem* 281: 6152-64.
- Matthews SA, Iglesias T, Rozengurt E, Cantrell D (2000) Spatial and temporal regulation of protein kinase D (PKD). *EMBO J* 19: 2935-45.
- Matthews SA, Navarro MN, Sinclair LV, Emslie E, Feijoo-Carnero C, Cantrell DA (2010) Unique functions for protein kinase D1 and protein kinase D2 in mammalian cells. *Biochem J* 432: 153-63.
- Matthews SA, Pettit GR, Rozengurt E (1997) Bryostatin 1 induces biphasic activation of protein kinase D in intact cells. *J Biol Chem* 272: 20245-50.
- Mauro A, Ciccarelli C, De Cesaris P, Scoglio A, Bouche M, Molinaro M, Aquino A, Zani BM (2002) PKC α -mediated ERK, JNK and p38 activation regulates the myogenic program in human rhabdomyosarcoma cells. *J Cell Sci* 115: 3587-99.
- Medkova M, Cho W (1999) Interplay of C1 and C2 domains of protein kinase C- α in its membrane binding and activation. *J Biol Chem* 274: 19852-61.
- Melowic HR, Stahelin RV, Blatner NR, Tian W, Hayashi K, Altman A, Cho W (2007) Mechanism of diacylglycerol-induced membrane targeting and activation of protein kinase C θ . *J Biol Chem* 282: 21467-76.
- Miyamoto A, Nakayama K, Imaki H, Hirose S, Jiang Y, Abe M, Tsukiyama T, Nagahama H, Ohno S, Hatakeyama S, Nakayama KI (2002) Increased proliferation of B cells and auto-immunity in mice lacking protein kinase C δ . *Nature* 416: 865-9.
- Mobarak CD, Anderson KD, Morin M, Beckel-Mitchener A, Rogers SL, Furneaux H, King P, Perrone-Bizzozero NI (2000) The RNA-binding protein HuD is required for GAP-43 mRNA stability, GAP-43 gene expression, and PKC-dependent neurite outgrowth in PC12 cells. *Mol Biol Cell* 11: 3191-203.

- Mochly-Rosen D (1995) Localization of protein kinases by anchoring proteins: A theme in signal transduction. *Science* 268: 247-51.
- Mochly-Rosen D, Das K, Grimes KV (2012) Protein kinase C, an elusive therapeutic target? *Nat Rev Drug Discov* 11: 937-57.
- Monaghan TK, Mackenzie CJ, Plevin R, Lutz EM (2008) PACAP-38 induces neuronal differentiation of human SH-SY5Y neuroblastoma cells via cAMP-mediated activation of ERK and p38 MAP kinases. *J Neurochem* 104: 74-88.
- Munsie LN, Desmond CR, Truant R (2012) Cofilin nuclear-cytoplasmic shuttling affects cofilin-actin rod formation during stress. *J Cell Sci* 125: 3977-88.
- Mutter R, Wills M (2000) Chemistry and clinical biology of the bryostatins. *Bioorg Med Chem* 8: 1841-60.
- Nacro K, Bienfait B, Lee J, Han KC, Kang JH, Benzaria S, Lewin NE, Bhattacharyya DK, Blumberg PM, Marquez VE (2000) Conformationally constrained analogues of diacylglycerol (DAG). 16. How much structural complexity is necessary for recognition and high binding affinity to protein kinase C? *J Med Chem* 43: 921-44.
- Nakagawa Y, Irie K, Nakamura Y, Ohigashi H, Hayashi H (1998) Synthesis and biological activities of (-)-6-n-octyl-indolactam-V, a new potent analogue of the tumor promoter (-)-indolactam-V. *Biosci Biotechnol Biochem* 62: 1568-73.
- Nakagawa Y, Irie K, Yanagita RC, Ohigashi H, Tsuda K, Kashiwagi K, Saito N (2006) Design and synthesis of 8-octyl-benzolactam-V9, a selective activator for protein kinase C ϵ and η . *J Med Chem* 49: 2681-8.
- Nakamura H, Kishi Y, Pajares MA, Rando RR (1989) Structural basis of protein kinase C activation by tumor promoters. *Proc Natl Acad Sci U S A* 86: 9672-6.
- Nakamura N, Oshiro N, Fukata Y, Amano M, Fukata M, Kuroda S, Matsuura Y, Leung T, Lim L, Kaibuchi K (2000) Phosphorylation of ERM proteins at filopodia induced by Cdc42. *Genes Cells* 5: 571-81.
- Nalefski EA, Newton AC (2001) Membrane binding kinetics of protein kinase C β II mediated by the C2 domain. *Biochemistry* 40: 13216-29.
- Nelson TJ, Alkon DL (2009) Neuroprotective versus tumorigenic protein kinase C activators. *Trends Biochem Sci* 34: 136-45.
- Newton AC (2001) Protein kinase C: Structural and spatial regulation by phosphorylation, cofactors, and macromolecular interactions. *Chem Rev* 101: 2353-64.
- Ng Y, Tan I, Lim L, Leung T (2004) Expression of the human myotonic dystrophy kinase-related Cdc42-binding kinase γ is regulated by promoter DNA methylation and Sp1 binding. *J Biol Chem* 279: 34156-64.
- Nishizuka Y (1984) The role of protein kinase C in cell surface signal transduction and tumour promotion. *Nature* 308: 693-8.
- Nishizuka Y (1988) The molecular heterogeneity of protein kinase C and its implications for cellular regulation. *Nature* 334: 661-5.
- Nishizuka Y (1992) Intracellular signaling by hydrolysis of phospholipids and activation of protein kinase C. *Science* 258: 607-14.
- Oancea E, Meyer T (1998) Protein kinase C as a molecular machine for decoding calcium and diacylglycerol signals. *Cell* 95: 307-18.
- Obrdlik A, Percipalle P (2011) The F-actin severing protein cofilin-1 is required for RNA polymerase II transcription elongation. *Nucleus* 2: 72-9.
- Ochoa WF, Corbalán-García S, Eritja R, Rodríguez-Alfaro JA, Gómez-Fernández JC, Fita I, Verdaguer N (2002) Additional binding sites for anionic phospholipids and calcium ions in the crystal structures of complexes of the C2 domain of protein kinase C α . *J Mol Biol* 320: 277-91.
- Ochoa WF, García-García J, Fita I, Corbalán-García S, Verdaguer N, Gómez-Fernández JC (2001) Structure of the C2 domain from novel protein kinase C ϵ . A membrane binding model for Ca²⁺-independent C2 domains. *J Mol Biol* 311: 837-49.
- Olayioye MA, Barisic S, Hausser A (2013) Multi-level control of actin dynamics by protein kinase D. *Cell Signal* 25: 1739-47.
- Ono Y, Fujii T, Igarashi K, Kuno T, Tanaka C, Kikkawa U, Nishizuka Y (1989) Phorbol ester binding to protein kinase C requires a cysteine-rich zinc-finger-like sequence. *Proc Natl Acad Sci U S A* 86: 4868-71.

- Ono Y, Fujii T, Ogita K, Kikkawa U, Igarashi K, Nishizuka Y (1987) Identification of three additional members of rat protein kinase C family: δ -, ϵ - and ζ -subspecies. *FEBS Lett* 226: 125-8.
- Osada S, Mizuno K, Saido TC, Akita Y, Suzuki K, Kuroki T, Ohno S (1990) A phorbol ester receptor/protein kinase, nPKC η , a new member of the protein kinase C family predominantly expressed in lung and skin. *J Biol Chem* 265: 22434-40.
- Osada S, Mizuno K, Saido TC, Suzuki K, Kuroki T, Ohno S (1992) A new member of the protein kinase C family, nPKC θ , predominantly expressed in skeletal muscle. *Mol Cell Biol* 12: 3930-8.
- Ostenson CG, Gaisano H, Sheu L, Tibell A, Bartfai T (2006) Impaired gene and protein expression of exocytotic soluble N-ethylmaleimide attachment protein receptor complex proteins in pancreatic islets of type 2 diabetic patients. *Diabetes* 55: 435-40.
- Paavilainen VO, Bertling E, Falck S, Lappalainen P (2004) Regulation of cytoskeletal dynamics by actin-monomer-binding proteins. *Trends Cell Biol* 14: 386-94.
- Pappa H, Murray-Rust J, Dekker LV, Parker PJ, McDonald NQ (1998) Crystal structure of the C2 domain from protein kinase C- δ . *Structure* 6: 885-94.
- Pascale A, Amadio M, Quattrone A (2008) Defining a neuron: Neuronal ELAV proteins. *Cell Mol Life Sci* 65: 128-40.
- Pascale A, Amadio M, Scapagnini G, Lanni C, Racchi M, Provenzani A, Govoni S, Alkon DL, Quattrone A (2005) Neuronal ELAV proteins enhance mRNA stability by a PKC α -dependent pathway. *Proc Natl Acad Sci U S A* 102: 12065-70.
- Pascale A, Gusev PA, Amadio M, Dottorini T, Govoni S, Alkon DL, Quattrone A (2004) Increase of the RNA-binding protein HuD and posttranscriptional up-regulation of the GAP-43 gene during spatial memory. *Proc Natl Acad Sci U S A* 101: 1217-22.
- Pennanen PT, Sarvilinna NS, Toimela T, Ylikomi TJ (2011) Inhibition of FOSL1 overexpression in antiestrogen-resistant MCF-7 cells decreases cell growth and increases vacuolization and cell death. *Steroids* 76: 1063-8.
- Petiti JP, De Paul AL, Gutiérrez S, Palmeri CM, Mukdsi JH, Torres AI (2008) Activation of PKC epsilon induces lactotroph proliferation through ERK1/2 in response to phorbol ester. *Mol Cell Endocrinol* 289: 77-84.
- Prince M, Bryce R, Albanese E, Wimo A, Ribeiro W, Ferri CP (2013) The global prevalence of dementia: A systematic review and metaanalysis. *Alzheimers Dement* 9: 63-75.
- Pu Y, Perry NA, Yang D, Lewin NE, Kedei N, Braun DC, Choi SH, Blumberg PM, Garfield SH, Stone JC, Duan D, Marquez VE (2005) A novel diacylglycerol-lactone shows marked selectivity in vitro among C1 domains of protein kinase C (PKC) isoforms α and δ as well as selectivity for RasGRP compared with PKC α . *J Biol Chem* 280: 27329-38.
- Påhlman S, Mamaeva S, Meyerson G, Mattsson ME, Bjelfman C, Ortoft E, Hammerling U (1990) Human neuroblastoma cells in culture: A model for neuronal cell differentiation and function. *Acta Physiol Scand Suppl* 592: 25-37.
- Quattrone A, Pascale A, Nogues X, Zhao W, Gusev P, Pacini A, Alkon DL (2001) Posttranscriptional regulation of gene expression in learning by the neuronal ELAV-like mRNA-stabilizing proteins. *Proc Natl Acad Sci U S A* 98: 11668-73.
- Rahman GM, Shanker S, Lewin NE, Kedei N, Hill CS, Prasad BV, Blumberg PM, Das J (2013) Identification of the activator-binding residues in the second cysteine-rich regulatory domain of protein kinase C θ (PKC θ). *Biochem J* 451: 33-44.
- Randhawa PK, Rylova S, Heinz JY, Kiser S, Fried JH, Dunworth WP, Anderson AL, Barber AT, Chappell JC, Roberts DM, Bautch VL (2011) The Ras activator RasGRP3 mediates diabetes-induced embryonic defects and affects endothelial cell migration. *Circ Res* 108: 1199-208.
- Redman C, Lefevre J, MacDonald ML (1995) Inhibition of diacylglycerol kinase by the antitumor agent calphostin C. evidence for similarity between the active site of diacylglycerol kinase and the regulatory site of protein kinase C. *Biochem Pharmacol* 50: 235-41.
- Reuther GW, Lambert QT, Rebhun JF, Caligiuri MA, Quilliam LA, Der CJ (2002) RasGRP4 is a novel Ras activator isolated from acute myeloid leukemia. *J Biol Chem* 277: 30508-14.
- Rhee JS, Betz A, Pyott S, Reim K, Varoqueaux F, Augustin I, Hesse D, Südhof TC, Takahashi M, Rosenmund C, Brose N (2002) β Phorbol ester- and diacylglycerol-induced augmentation of transmitter release is mediated by Munc13s and not by PKCs. *Cell* 108: 121-33.

- Rhee SG (2001) Regulation of phosphoinositide-specific phospholipase C. *Annu Rev Biochem* 70: 281-312.
- Riccomagno MM, Hurtado A, Wang H, Macopson JG, Griner EM, Betz A, Brose N, Kazanietz MG, Kolodkin AL (2012) The RacGAP β 2-chimaerin selectively mediates axonal pruning in the hippocampus. *Cell* 149: 1594-606.
- Rizo J, Südhof TC (1998) C2-domains, structure and function of a universal Ca^{2+} -binding domain. *J Biol Chem* 273: 15879-82.
- Roaten JB, Kazanietz MG, Caloca MJ, Bertics PJ, Lothstein L, Parrill AL, Israel M, Sweatman TW (2002) Interaction of the novel anthracycline antitumor agent *N*-benzyladriamycin-14-valerate with the C1-regulatory domain of protein kinase C: Structural requirements, isoform specificity, and correlation with drug cytotoxicity. *Mol Cancer Ther* 1: 483-92.
- Roaten JB, Kazanietz MG, Sweatman TW, Lothstein L, Israel M, Parrill AL (2001) Molecular models of *N*-benzyladriamycin-14-valerate (AD 198) in complex with the phorbol ester-binding C1b domain of protein kinase C- δ . *J Med Chem* 44: 1028-34.
- Roffey J, Rosse C, Linch M, Hibbert A, McDonald NQ, Parker PJ (2009) Protein kinase C intervention: The state of play. *Curr Opin Cell Biol* 21: 268-79.
- Roh JH, Qiu A, Seo SW, Soon HW, Kim JH, Kim GH, Kim MJ, Lee JM, Na DL (2011) Volume reduction in subcortical regions according to severity of Alzheimer's disease. *J Neurol* 258: 1013-20.
- Rong SB, Enyedy IJ, Qiao L, Zhao L, Ma D, Pearce LL, Lorenzo PS, Stone JC, Blumberg PM, Wang S, Kozikowski AP (2002) Structural basis of RasGRP binding to high-affinity PKC ligands. *J Med Chem* 45: 853-60.
- Roose JP, Mollenauer M, Gupta VA, Stone J, Weiss A (2005) A diacylglycerol-protein kinase C-RasGRP1 pathway directs Ras activation upon antigen receptor stimulation of T cells. *Mol Cell Biol* 25: 4426-41.
- Roskoski R Jr (2012) ERK1/2 MAP kinases: Structure, function, and regulation. *Pharmacol Res* 66: 105-43.
- Rossner S, Fuchsbrunner K, Lange-Dohna C, Hartlage-Rübsamen M, Bigl V, Betz A, Reim K, Brose N (2004) Munc13-1-mediated vesicle priming contributes to secretory amyloid precursor protein processing. *J Biol Chem* 279: 27841-4.
- Rotenberg SA, Huang MH, Zhu J, Su L, Riedel H (1995) Deletion analysis of protein kinase C inactivation by calphostin C. *Mol Carcinog* 12: 42-9.
- Rovera G, O'Brien TG, Diamond L (1979) Induction of differentiation in human promyelocytic leukemia cells by tumor promoters. *Science* 204: 868-70.
- Rozengurt E, Rey O, Waldron RT (2005) Protein kinase D signaling. *J Biol Chem* 280: 13205-8.
- Sakane F, Imai S, Kai M, Yasuda S, Kanoh H (2007) Diacylglycerol kinases: Why so many of them? *Biochim Biophys Acta* 1771: 793-806.
- Sakane F, Imai S, Kai M, Yasuda S, Kanoh H (2008) Diacylglycerol kinases as emerging potential drug targets for a variety of diseases. *Curr Drug Targets* 9: 626-40.
- Sampson SR, Cooper DR (2006) Specific protein kinase C isoforms as transducers and modulators of insulin signaling. *Mol Genet Metab* 89: 32-47.
- Sandler C, Ekokoski E, Lindstedt KA, Vainio PJ, Finel M, Sorsa T, Kovanen PT, Golub LM, Eklund KK (2005) Chemically modified tetracycline (CMT)-3 inhibits histamine release and cytokine production in mast cells: Possible involvement of protein kinase C. *Inflamm Res* 54: 304-12.
- Sarkar FH, Li Y (2009) Harnessing the fruits of nature for the development of multi-targeted cancer therapeutics. *Cancer Treat Rev* 35: 597-607.
- Schultz A, Ling M, Larsson C (2004) Identification of an amino acid residue in the protein kinase C C1b domain crucial for its localization to the Golgi network. *J Biol Chem* 279: 31750-60.
- Schwartz JH (1993) Cognitive kinases. *Proc Natl Acad Sci U S A* 90: 8310-3.
- Schönwasser DC, Marais RM, Marshall CJ, Parker PJ (1998) Activation of the mitogen-activated protein kinase/extracellular signal-regulated kinase pathway by conventional, novel, and atypical protein kinase C isotypes. *Mol Cell Biol* 18: 790-8.
- Selkoe DJ (2001) Alzheimer's disease: Genes, proteins, and therapy. *Physiol Rev* 81: 741-66.
- Selkoe DJ (2002) Alzheimer's disease is a synaptic failure. *Science* 298: 789-91.

- Sharkey NA, Leach KL, Blumberg PM (1984) Competitive inhibition by diacylglycerol of specific phorbol ester binding. *Proc Natl Acad Sci U S A* 81: 607-10.
- Shen N, Guryev O, Rizo J (2005) Intramolecular occlusion of the diacylglycerol-binding site in the C1 domain of Munc13-1. *Biochemistry* 44: 1089-96.
- Sheu L, Pasyk EA, Ji J, Huang X, Gao X, Varoquaux F, Brose N, Gaisano HY (2003) Regulation of insulin exocytosis by Munc13-1. *J Biol Chem* 278: 27556-63.
- Shin OH, Lu J, Rhee JS, Tomchick DR, Pang ZP, Wojcik SM, Camacho-Perez M, Brose N, Machius M, Rizo J, Rosenmund C, Südhof TC (2010) Munc13 C2B domain is an activity-dependent Ca²⁺ regulator of synaptic exocytosis. *Nat Struct Mol Biol* 17: 280-8.
- Shindo M, Irie K, Masuda A, Ohigashi H, Shirai Y, Miyasaka K, Saito N (2003) Synthesis and phorbol ester binding of the cysteine-rich domains of diacylglycerol kinase (DGK) isozymes. DGK γ and DGK β are new targets of tumor-promoting phorbol esters. *J Biol Chem* 278: 18448-54.
- Shirai Y, Kouzuki T, Kakefuda K, Moriguchi S, Oyagi A, Horie K, Morita SY, Shimazawa M, Fukunaga K, Takeda J, Saito N, Hara H (2010) Essential role of neuron-enriched diacylglycerol kinase (DGK), DGK β in neurite spine formation, contributing to cognitive function. *PLoS One* 5: e11602.
- Shirai Y, Segawa S, Kuriyama M, Goto K, Sakai N, Saito N (2000) Subtype-specific translocation of diacylglycerol kinase α and γ and its correlation with protein kinase C. *J Biol Chem* 275: 24760-6.
- Shulga YV, Topham MK, Epand RM (2011) Regulation and functions of diacylglycerol kinases. *Chem Rev* 111: 6186-208.
- Slater SJ, Ho C, Kelly MB, Larkin JD, Taddeo FJ, Yeager MD, Stubbs CD (1996) Protein kinase C α contains two activator binding sites that bind phorbol esters and diacylglycerols with opposite affinities. *J Biol Chem* 271: 4627-31.
- Song Y, Ailenberg M, Silverman M (1999) Human munc13 is a diacylglycerol receptor that induces apoptosis and may contribute to renal cell injury in hyperglycemia. *Mol Biol Cell* 10: 1609-19.
- Spitaler M, Cantrell DA (2004) Protein kinase C and beyond. *Nat Immunol* 5: 785-90.
- Stahelin RV, Digman MA, Medkova M, Ananthanarayanan B, Melowic HR, Rafter JD, Cho W (2005) Diacylglycerol-induced membrane targeting and activation of protein kinase C ϵ : Mechanistic differences between protein kinases C δ and C ϵ . *J Biol Chem* 280: 19784-93.
- Stahelin RV, Digman MA, Medkova M, Ananthanarayanan B, Rafter JD, Melowic HR, Cho W (2004) Mechanism of diacylglycerol-induced membrane targeting and activation of protein kinase C δ . *J Biol Chem* 279: 29501-12.
- Stang SL, Lopez-Campistrous A, Song X, Dower NA, Blumberg PM, Wender PA, Stone JC (2009) A proapoptotic signaling pathway involving RasGRP, Erk, and Bim in B cells. *Exp Hematol* 37: 122-34.
- Steinberg SF (2008) Structural basis of protein kinase C isoform function. *Physiol Rev* 88: 1341-78.
- Steinberg SF (2012) Regulation of protein kinase D1 activity. *Mol Pharmacol* 81: 284-91.
- Stengel K, Zheng Y (2011) Cdc42 in oncogenic transformation, invasion, and tumorigenesis. *Cell Signal* 23: 1415-23.
- Stone JC (2011) Regulation and function of the RasGRP family of Ras activators in blood cells. *Genes Cancer* 2: 320-34.
- Stone JC, Stang SL, Zheng Y, Dower NA, Brenner SE, Baryza JL, Wender PA (2004) Synthetic bryostatin analogues activate the RasGRP1 signaling pathway. *J Med Chem* 47: 6638-44.
- Subramanian A, Tamayo P, Mootha VK, Mukherjee S, Ebert BL, Gillette MA, Paulovich A, Pomeroy SL, Golub TR, Lander ES, Mesirov JP (2005) Gene set enrichment analysis: A knowledge-based approach for interpreting genome-wide expression profiles. *Proc Natl Acad Sci U S A* 102: 15545-50.
- Suire S, Lecureuil C, Anderson KE, Damoulakis G, Niewczas I, Davidson K, Guillou H, Pan D, Jonathan C, Phillip TH, Stephens L (2012) GPCR activation of Ras and PI3K γ in neutrophils depends on PLC β 2/ β 3 and the RasGEF RasGRP4. *EMBO J* 31: 3118-29.
- Sumi T, Matsumoto K, Shibuya A, Nakamura T (2001) Activation of LIM kinases by myotonic dystrophy kinase-related Cdc42-binding kinase α . *J Biol Chem* 276: 23092-6.
- Sun MK, Alkon DL (2010) Pharmacology of protein kinase C activators: Cognition-enhancing and antidementic therapeutics. *Pharmacol Ther* 127: 66-77.

- Sun MK, Hongpaisan J, Alkon DL (2009) Postischemic PKC activation rescues retrograde and anterograde long-term memory. *Proc Natl Acad Sci U S A* 106: 14676-80.
- Sun Z, Arendt CW, Ellmeier W, Schaeffer EM, Sunshine MJ, Gandhi L, Annes J, Petrzilka D, Kupfer A, Schwartzberg PL, Littman DR (2000) PKC- θ is required for TCR-induced NF- κ B activation in mature but not immature T lymphocytes. *Nature* 404: 402-7.
- Sundram V, Chauhan SC, Jaggi M (2011) Emerging roles of protein kinase D1 in cancer. *Mol Cancer Res* 9: 985-96.
- Sunesson L, Hellman U, Larsson C (2008) Protein kinase C ϵ binds peripherin and induces its aggregation, which is accompanied by apoptosis of neuroblastoma cells. *J Biol Chem* 283: 16653-64.
- Sutton RB, Davletov BA, Berghuis AM, Südhof TC, Sprang SR (1995) Structure of the first C2 domain of synaptotagmin I: A novel Ca²⁺/phospholipid-binding fold. *Cell* 80: 929-38.
- Sutton RB, Sprang SR (1998) Structure of the protein kinase C β phospholipid-binding C2 domain complexed with Ca²⁺. *Structure* 6: 1395-405.
- Szállási Z, Denning MF, Smith CB, Dlugosz AA, Yuspa SH, Pettit GR, Blumberg PM (1994a) Bryostatin 1 protects protein kinase C- δ from down-regulation in mouse keratinocytes in parallel with its inhibition of phorbol ester-induced differentiation. *Mol Pharmacol* 46: 840-50.
- Szállási Z, Smith CB, Pettit GR, Blumberg PM (1994b) Differential regulation of protein kinase C isozymes by bryostatin 1 and phorbol 12-myristate 13-acetate in NIH 3T3 fibroblasts. *J Biol Chem* 269: 2118-24.
- Söderholm H, Olsson A, Lavenius E, Rönstrand L, Nånberg E (2001) Activation of Ras, Raf-1 and protein kinase C in differentiating human neuroblastoma cells after treatment with phorbol ester and NGF. *Cell Signal* 13: 95-104.
- Takahashi M, Yamamoto T, Sakai H, Sakane F (2012) Calcium negatively regulates an intramolecular interaction between the N-terminal recoverin homology and EF-hand motif domains and the C-terminal C1 and catalytic domains of diacylglycerol kinase α . *Biochem Biophys Res Commun* 423: 571-6.
- Takai Y, Kishimoto A, Inoue M, Nishizuka Y (1977) Studies on a cyclic nucleotide-independent protein kinase and its proenzyme in mammalian tissues. I. Purification and characterization of an active enzyme from bovine cerebellum. *J Biol Chem* 252: 7603-9.
- Takai Y, Kishimoto A, Iwasa Y, Kawahara Y, Mori T, Nishizuka Y (1979) Calcium-dependent activation of a multifunctional protein kinase by membrane phospholipids. *J Biol Chem* 254: 3692-5.
- Takeuchi S, Yamaki N, Iwasato T, Negishi M, Katoh H (2009) β 2-Chimaerin binds to EphA receptors and regulates cell migration. *FEBS Lett* 583: 1237-42.
- Tammela P, Ekokoski E, García-Horsman A, Talman V, Finel M, Tuominen RK, Vuorela P (2004) Screening of natural compounds and their derivatives as potential protein kinase C inhibitors. *Drug Dev Res* 63: 76-87.
- Tan I, Cheong A, Lim L, Leung T (2003) Genomic organization of human myotonic dystrophy kinase-related Cdc42-binding kinase α reveals multiple alternative splicing and functional diversity. *Gene* 304: 107-15.
- Tan I, Lai J, Yong J, Li SF, Leung T (2011) Chelerythrine perturbs lamellar actomyosin filaments by selective inhibition of myotonic dystrophy kinase-related Cdc42-binding kinase. *FEBS Lett* 585: 1260-8.
- Tan I, Ng CH, Lim L, Leung T (2001a) Phosphorylation of a novel myosin binding subunit of protein phosphatase 1 reveals a conserved mechanism in the regulation of actin cytoskeleton. *J Biol Chem* 276: 21209-16.
- Tan I, Seow KT, Lim L, Leung T (2001b) Intermolecular and intramolecular interactions regulate catalytic activity of myotonic dystrophy kinase-related Cdc42-binding kinase α . *Mol Cell Biol* 21: 2767-78.
- Tan I, Yong J, Dong JM, Lim L, Leung T (2008) A tripartite complex containing MRCK modulates lamellar actomyosin retrograde flow. *Cell* 135: 123-36.
- Tan SL, Parker PJ (2003) Emerging and diverse roles of protein kinase C in immune cell signalling. *Biochem J* 376: 545-52.
- Tanino F, Maeda Y, Sakai H, Sakane F (2012) Induction of filopodia-like protrusions in N1E-115 neuroblastoma cells by diacylglycerol kinase γ independent of its enzymatic activity: Potential novel function of the C-terminal region containing the catalytic domain of diacylglycerol kinase γ . *Mol Cell Biochem* 373: 85-93.
- Tazmini G, Beaulieu N, Woo A, Zahedi B, Goulding RE, Kay RJ (2009) Membrane localization of RasGRP1 is controlled by an EF-hand, and by the GEF domain. *Biochim Biophys Acta* 1793: 447-61.

- Teixeira C, Stang SL, Zheng Y, Beswick NS, Stone JC (2003) Integration of DAG signaling systems mediated by PKC-dependent phosphorylation of RasGRP3. *Blood* 102: 1414-20.
- Tognon CE, Kirk HE, Passmore LA, Whitehead IP, Der CJ, Kay RJ (1998) Regulation of RasGRP via a phorbol ester-responsive C1 domain. *Mol Cell Biol* 18: 6995-7008.
- Toimela T, Tähti H, Ylikomi T (2008) Comparison of an automated pattern analysis machine vision time-lapse system with traditional endpoint measurements in the analysis of cell growth and cytotoxicity. *Altern Lab Anim* 36: 313-25.
- Tojkander S, Gateva G, Lappalainen P (2012) Actin stress fibers – assembly, dynamics and biological roles. *J Cell Sci* 125: 1855-64.
- Toki S, Kawasaki H, Tashiro N, Housman DE, Graybiel AM (2001) Guanine nucleotide exchange factors CalDAG-GEFI and CalDAG-GEFII are colocalized in striatal projection neurons. *J Comp Neurol* 437: 398-407.
- Topham MK, Epand RM (2009) Mammalian diacylglycerol kinases: Molecular interactions and biological functions of selected isoforms. *Biochim Biophys Acta* 1790: 416-24.
- Tourkina E, Gooz P, Pannu J, Bonner M, Scholz D, Hacker S, Silver RM, Trojanowska M, Hoffman S (2005) Opposing effects of protein kinase C α and protein kinase C ϵ on collagen expression by human lung fibroblasts are mediated via MEK/ERK and caveolin-1 signaling. *J Biol Chem* 280: 13879-87.
- Trauzold A, Schmiedel S, Sipos B, Wermann H, Westphal S, Röder C, Klapper W, Arlt A, Lehnert L, Ungefroren H, Johannes FJ, Kalthoff H (2003) PKC μ prevents CD95-mediated apoptosis and enhances proliferation in pancreatic tumour cells. *Oncogene* 22: 8939-47.
- Trollér U, Larsson C (2006) Cdc42 is involved in PKC ϵ - and δ -induced neurite outgrowth and stress fibre dismantling. *Biochem Biophys Res Commun* 349: 91-8.
- Trollér U, Zeidman R, Svensson K, Larsson C (2001) A PKC β isoform mediates phorbol ester-induced activation of Erk1/2 and expression of neuronal differentiation genes in neuroblastoma cells. *FEBS Lett* 508: 126-30.
- Truman JP, Rotenberg SA, Kang JH, Lerman G, Fuks Z, Kolesnick R, Marquez VE, Haimovitz-Friedman A (2009) PKC α activation downregulates ATM and radio-sensitizes androgen-sensitive human prostate cancer cells *in vitro* and *in vivo*. *Cancer Biol Ther* 8: 54-63.
- Tsushima S, Kai M, Yamada K, Imai S, Houkin K, Kanoh H, Sakane F (2004) Diacylglycerol kinase γ serves as an upstream suppressor of Rac1 and lamellipodium formation. *J Biol Chem* 279: 28603-13.
- Turban S, Hajdich E (2011) Protein kinase C isoforms: Mediators of reactive lipid metabolites in the development of insulin resistance. *FEBS Lett* 585: 269-74.
- Tuthill MC, Oki CE, Lorenzo PS (2006) Differential effects of bryostatin 1 and 12-O-tetradecanoylphorbol-13-acetate on the regulation and activation of RasGRP1 in mouse epidermal keratinocytes. *Mol Cancer Ther* 5: 602-10.
- Ueda Y, Hirai S, Osada S, Suzuki A, Mizuno K, Ohno S (1996) Protein kinase C activates the MEK-ERK pathway in a manner independent of Ras and dependent on Raf. *J Biol Chem* 271: 23512-9.
- van Duuren BL, Tseng SS, Segal A, Smith AC, Melchionne S, Seidman I (1979) Effects of structural changes on the tumor-promoting activity of phorbol myristate acetate on mouse skin. *Cancer Res* 39: 2644-6.
- van Rheenen J, Condeelis J, Glogauer M (2009) A common cofilin activity cycle in invasive tumor cells and inflammatory cells. *J Cell Sci* 122: 305-11.
- Varoqueaux F, Sigler A, Rhee JS, Brose N, Enk C, Reim K, Rosenmund C (2002) Total arrest of spontaneous and evoked synaptic transmission but normal synaptogenesis in the absence of Munc13-mediated vesicle priming. *Proc Natl Acad Sci U S A* 99: 9037-42.
- Verdaguer N, Corbalán-García S, Ochoa WF, Fita I, Gómez-Fernández JC (1999) Ca²⁺ bridges the C2 membrane-binding domain of protein kinase C α directly to phosphatidylserine. *EMBO J* 18: 6329-38.
- Vertommen D, Rider M, Ni Y, Waelkens E, Merlevede W, Vandenheede JR, Van Lint J (2000) Regulation of protein kinase D by multisite phosphorylation. Identification of phosphorylation sites by mass spectrometry and characterization by site-directed mutagenesis. *J Biol Chem* 275: 19567-76.
- Villani M, Subathra M, Im YB, Choi Y, Signorelli P, Del Poeta M, Luberto C (2008) Sphingomyelin synthases regulate production of diacylglycerol at the Golgi. *Biochem J* 414: 31-41.
- Waldron RT, Rozengurt E (2003) Protein kinase C phosphorylates protein kinase D activation loop Ser744 and Ser748 and releases autoinhibition by the pleckstrin homology domain. *J Biol Chem* 278: 154-63.

- Wang H, Kazanietz MG (2010) p23/Tmp21 differentially targets the Rac-GAP β 2-chimaerin and protein kinase C via their C1 domains. *Mol Biol Cell* 21: 1398-408.
- Wang H, Yang C, Leskow FC, Sun J, Canagarajah B, Hurley JH, Kazanietz MG (2006) Phospholipase C γ /diacylglycerol-dependent activation of β 2-chimaerin restricts EGF-induced Rac signaling. *EMBO J* 25: 2062-74.
- Wang HY, Pisano MR, Friedman E (1994) Attenuated protein kinase C activity and translocation in Alzheimer's disease brain. *Neurobiol Aging* 15: 293-8.
- Wang QJ (2006) PKD at the crossroads of DAG and PKC signaling. *Trends Pharmacol Sci* 27: 317-23.
- Wang QJ, Bhattacharyya D, Garfield S, Nacro K, Marquez VE, Blumberg PM (1999) Differential localization of protein kinase C δ by phorbol esters and related compounds using a fusion protein with green fluorescent protein. *J Biol Chem* 274: 37233-9.
- Wang QJ, Fang TW, Fenick D, Garfield S, Bienfait B, Marquez VE, Blumberg PM (2000) The lipophilicity of phorbol esters as a critical factor in determining the pattern of translocation of protein kinase C δ fused to green fluorescent protein. *J Biol Chem* 275: 12136-46.
- Wang QJ, Fang TW, Yang D, Lewin NE, Van Lint J, Marquez VE, Blumberg PM (2003) Ligand structure-activity requirements and phospholipid dependence for the binding of phorbol esters to protein kinase D. *Mol Pharmacol* 64: 1342-8.
- Wang S, Zaharevitz DW, Sharma R, Marquez VE, Lewin NE, Du L, Blumberg PM, Milne GW (1994) The discovery of novel, structurally diverse protein kinase C agonists through computer 3D-database pharmacophore search. Molecular modeling studies. *J Med Chem* 37: 4479-89.
- Wender PA, Baryza JL, Brenner SE, DeChristopher BA, Loy BA, Schrier AJ, Verma VA (2011) Design, synthesis, and evaluation of potent bryostatin analogs that modulate PKC translocation selectivity. *Proc Natl Acad Sci U S A* 108: 6721-6.
- Wender PA, DeBrabander J, Harran PG, Jimenez JM, Koehler MF, Lippa B, Park CM, Siedenbiedel C, Pettit GR (1998) The design, computer modeling, solution structure, and biological evaluation of synthetic analogs of bryostatin 1. *Proc Natl Acad Sci U S A* 95: 6624-9.
- Wender PA, Kee JM, Warrington JM (2008) Practical synthesis of prostratin, DPP, and their analogs, adjuvant leads against latent HIV. *Science* 320: 649-52.
- Wender PA, Lippa B, Park CM, Irie K, Nakahara A, Ohigashi H (1999) Selective binding of bryostatin analogues to the cysteine rich domains of protein kinase C isozymes. *Bioorg Med Chem Lett* 9: 1687-90.
- Wierda KD, Toonen RF, de Wit H, Brussaard AB, Verhage M (2007) Interdependence of PKC-dependent and PKC-independent pathways for presynaptic plasticity. *Neuron* 54: 275-90.
- Wilkinson S, Paterson HF, Marshall CJ (2005) Cdc42-MRCK and Rho-ROCK signalling cooperate in myosin phosphorylation and cell invasion. *Nat Cell Biol* 7: 255-61.
- Wolfenson H, Henis YI, Geiger B, Bershadsky AD (2009) The heel and toe of the cell's foot: A multifaceted approach for understanding the structure and dynamics of focal adhesions. *Cell Motil Cytoskeleton* 66: 1017-29.
- Wong C, Jin ZG (2005) Protein kinase C-dependent protein kinase D activation modulates ERK signal pathway and endothelial cell proliferation by vascular endothelial growth factor. *J Biol Chem* 280: 33262-9.
- Xu ZB, Chaudhary D, Olland S, Wolfrom S, Czerwinski R, Malakian K, Lin L, Stahl ML, Joseph-McCarthy D, Benander C, Fitz L, Greco R, Somers WS, Mosyak L (2004) Catalytic domain crystal structure of protein kinase C- θ (PKC θ). *J Biol Chem* 279: 50401-9.
- Yamada K, Sakane F, Imai S, Tsushima S, Murakami T, Kanoh H (2003) Regulatory role of diacylglycerol kinase γ in macrophage differentiation of leukemia cells. *Biochem Biophys Res Commun* 305: 101-7.
- Yamaguchi Y, Shirai Y, Matsubara T, Sanse K, Kuriyama M, Oshiro N, Yoshino K, Yonezawa K, Ono Y, Saito N (2006) Phosphorylation and up-regulation of diacylglycerol kinase γ via its interaction with protein kinase C γ . *J Biol Chem* 281: 31627-37.
- Yang C, Kazanietz MG (2003) Divergence and complexities in DAG signaling: Looking beyond PKC. *Trends Pharmacol Sci* 24: 602-8.
- Yang C, Kazanietz MG (2007) Chimaerins: GAPs that bridge diacylglycerol signalling and the small G-protein Rac. *Biochem J* 403: 1-12.

- Yang C, Liu Y, Leskow FC, Weaver VM, Kazanietz MG (2005) Rac-GAP-dependent inhibition of breast cancer cell proliferation by β 2-chimerin. *J Biol Chem* 280: 24363-70.
- Yang D, Kedei N, Li L, Tao J, Velasquez JF, Michalowski AM, Toth BI, Marincsak R, Varga A, Biro T, Yuspa SH, Blumberg PM (2010) RasGRP3 contributes to formation and maintenance of the prostate cancer phenotype. *Cancer Res* 70: 7905-17.
- Yang D, Tao J, Li L, Kedei N, Toth ZE, Czap A, Velasquez JF, Mihova D, Michalowski AM, Yuspa SH, Blumberg PM (2011) RasGRP3, a Ras activator, contributes to signaling and the tumorigenic phenotype in human melanoma. *Oncogene* 30: 4590-600.
- Yang Y, Li L, Wong GW, Krilis SA, Madhusudhan MS, Sali A, Stevens RL (2002) RasGRP4, a new mast cell-restricted Ras guanine nucleotide-releasing protein with calcium- and diacylglycerol-binding motifs. Identification of defective variants of this signaling protein in asthma, mastocytosis, and mast cell leukemia patients and demonstration of the importance of RasGRP4 in mast cell development and function. *J Biol Chem* 277: 25756-74.
- Yasuda S, Kai M, Imai S, Kanoh H, Sakane F (2007) Diacylglycerol kinase γ interacts with and activates β 2-chimaerin, a Rac-specific GAP, in response to epidermal growth factor. *FEBS Lett* 581: 551-7.
- Yi P, Schrott L, Castor TP, Alexander JS (2012) Bryostatin-1 vs. TPPB: Dose-dependent APP processing and PKC- α , - δ , and - ϵ isoform activation in SH-SY5Y neuronal cells. *J Mol Neurosci* 48: 234-44.
- Yuan S, Miller DW, Barnett GH, Hahn JF, Williams BR (1995) Identification and characterization of human β 2-chimaerin: Association with malignant transformation in astrocytoma. *Cancer Res* 55: 3456-61.
- Zeidman R, Löfgren B, Pählman S, Larsson C (1999a) PKC ϵ , via its regulatory domain and independently of its catalytic domain, induces neurite-like processes in neuroblastoma cells. *J Cell Biol* 145: 713-26.
- Zeidman R, Pettersson L, Sailaja PR, Truedsson E, Fagerström S, Pählman S, Larsson C (1999b) Novel and classical protein kinase C isoforms have different functions in proliferation, survival and differentiation of neuroblastoma cells. *Int J Cancer* 81: 494-501.
- Zhang EY, Kong KF, Altman A (2013) The yin and yang of protein kinase C-theta (PKC θ): A novel drug target for selective immunosuppression. *Adv Pharmacol* 66: 267-312.
- Zhang G, Kazanietz MG, Blumberg PM, Hurley JH (1995) Crystal structure of the cys2 activator-binding domain of protein kinase C δ in complex with phorbol ester. *Cell* 81: 917-24.
- Zheng Y, Liu H, Coughlin J, Zheng J, Li L, Stone JC (2005) Phosphorylation of RasGRP3 on threonine 133 provides a mechanistic link between PKC and Ras signaling systems in B cells. *Blood* 105: 3648-54.