



## **Studies and Applications of Metals for the Synthesis of Carbinols, Amides and Carbohydrates**

**Osztrovszky, Gyorgyi; Holm, Torkil; Madsen, Robert**

*Publication date:*  
2012

*Document Version*  
Publisher's PDF, also known as Version of record

[Link back to DTU Orbit](#)

*Citation (APA):*  
Osztrovszky, G., Holm, T., & Madsen, R. (2012). Studies and Applications of Metals for the Synthesis of Carbinols, Amides and Carbohydrates. Kgs. Lyngby: Technical University of Denmark (DTU).

## **DTU Library** Technical Information Center of Denmark

---

### **General rights**

Copyright and moral rights for the publications made accessible in the public portal are retained by the authors and/or other copyright owners and it is a condition of accessing publications that users recognise and abide by the legal requirements associated with these rights.

- Users may download and print one copy of any publication from the public portal for the purpose of private study or research.
- You may not further distribute the material or use it for any profit-making activity or commercial gain
- You may freely distribute the URL identifying the publication in the public portal

If you believe that this document breaches copyright please contact us providing details, and we will remove access to the work immediately and investigate your claim.

# **Studies and Applications of Metals for the Synthesis of Carbinols, Amides and Carbohydrates**

**PhD Thesis**

**Györgyi Osztrovszky  
November 2011**



**Department of Chemistry  
Technical University of Denmark**



## Acknowledgements

First, I would like to extend my gratitude to my family and my friends for their support and patience.

I am very grateful to Professor Robert Madsen for supervising me during the three years I have spent in his group and his careful guidance on both practical and theoretical aspects of organic chemistry.

I would like to thank Professor Mark von Itzstein for the opportunity to join to his group at the Institute for Glycomics at Griffith University for eight months. It was extremely inspiring to be part of his research group and he always supported me through the critical stages of the project. My time in Australia was very memorable and many people made my stay there not only educational, but also with lots of fun.

I am very grateful to Dr. Torkil Holm. He has always been very helpful and made my life a lot easier from the first time I came to Denmark.

At DTU I have had the pleasure of sharing the lab with Agnese Maggi. I would like to express my thanks to her for the great time we have had working together and for numerous discussions on chemical problems. Additionally, the entire Madsen group, as well as people at the Department of Chemistry, building 201, both past and present, are gratefully thanked for creating a good working atmosphere.

Special thanks go to Gyula Dekany for the invaluable help, for the in-depth discussions on the problems I have encountered along the way and for the occasional baguette dinners.

I would like to express my gratitude to Dr. Christoph Röhrig and Agnese Maggi for carefully proofreading this thesis. Of course, any errors or omissions that may remain are the sole responsibility of the author.

Finally, the Technical University of Denmark (DTU) and the Torkil Holm Foundation are acknowledged for a PhD fellowship.

Györgyi Osztrovszky

Kgs. Lyngby, November 2011

## Abstract

The present dissertation describes the research performed at the Technical University of Denmark and at the Institute for Glycomics in the period April 2008 – Oct 2011. The thesis involves four discrete topics related to organometallic and carbohydrate chemistry.

### Project 1: Ultrafast Grignard addition reactions in the presence of protic agents

The addition of allylmagnesium bromide and benzylmagnesium chloride to carbonyl compounds was studied in the presence of protic agents (e.g. water, methanol, ethanol, phenol). In a number of cases, especially by the use of allylmagnesium bromide the carbonyl addition was found to be faster or comparable to the protonation by the reagent.

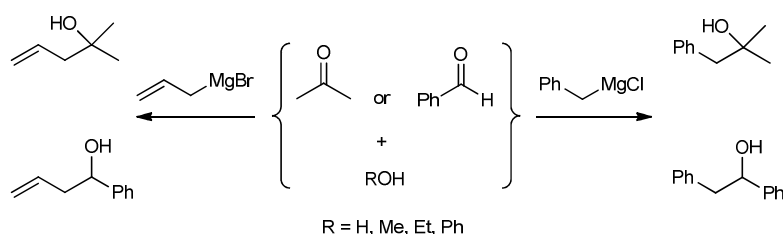

#### *Project 1: Competition experiments with the Grignard addition reaction*

### Project 2: Ruthenium catalyzed synthesis of amides from primary alcohols and amines

The direct synthesis of amides from alcohols and amines with the simultaneous liberation of dihydrogen was previously discovered in the Madsen group. Further development of the reaction conditions were investigated, in which stoichiometric additives or hydrogen acceptors were not required and the reactions were catalyzed by ruthenium *N*-heterocyclic carbene complexes. Two catalyst systems were found to be effective promoters for the amidation. These two systems do not show any significant differences in reactivity indicating that the same catalytically active species is operating.

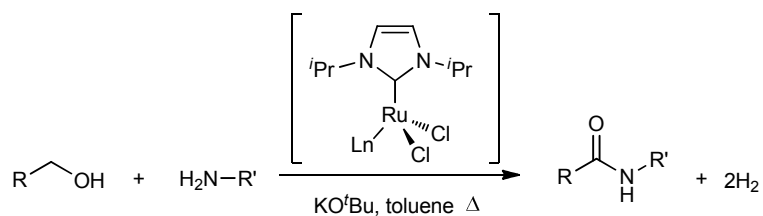

#### *Project 2: Amide synthesis catalyzed by N-heterocyclic carbene complexes*

### Project 3: Synthesis of a trisaccharide probe as a putative dengue virus receptor

At the Institute for Glycomics major research has been devoted to identify putative receptors for dengue virus (DENV). Based on previous studies the GlcNAc $\beta$ 1-3Gal $\beta$ 1-4GlcNAc trisaccharide was considered as a putative virus receptor. The synthesis of the trisaccharide probe has been achieved by the coupling of the corresponding D-glucosamine donor and the lactosamine acceptor, followed by deprotection. The biological investigation is in process.

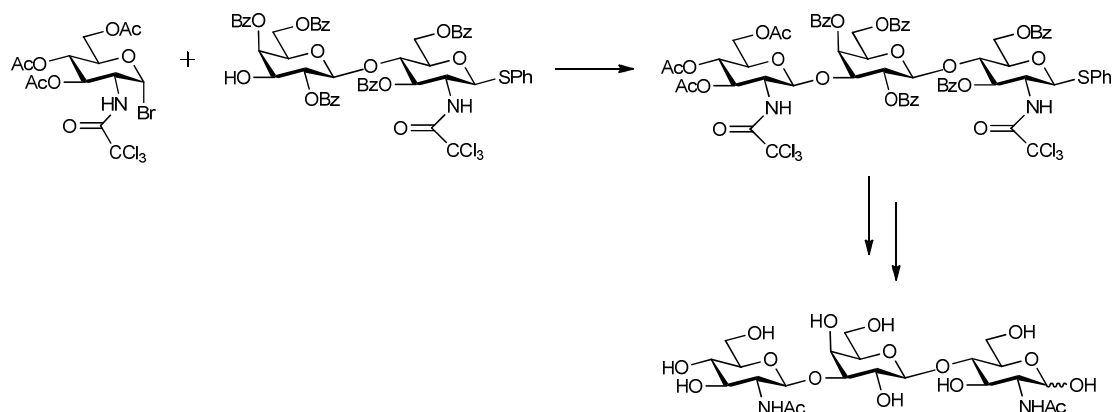

### *Project 3: Synthesis of GlcNAc $\beta$ 1-3Gal $\beta$ 1-4GlcNAc trisaccharide*

### Project 4: Glycosylation with unprotected acceptors

Regioselective Koenigs-Knorr glycosylation has been studied with a number of unprotected acceptors by means of organoboron derivatives, which can either activate or block *cis*-diols via ester formation. By means of phenylboronic acid high regioselective and stereospecific glycosidic bond formations were achieved.

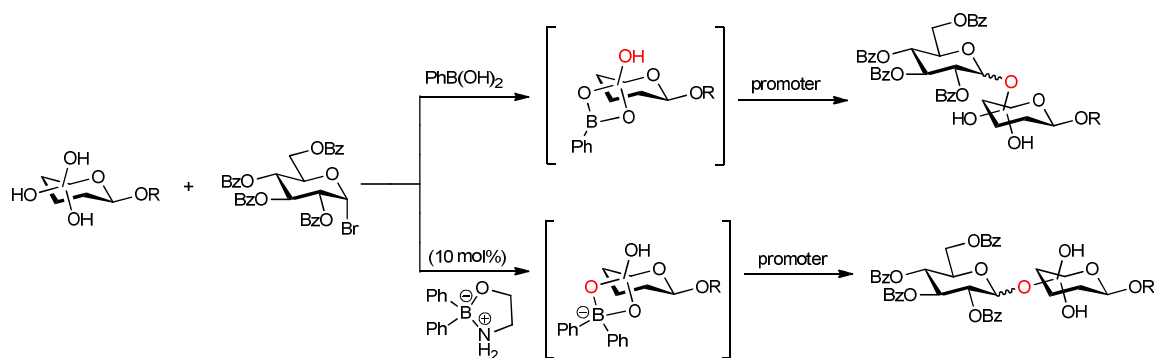

### *Project 4: Regioselective glycosylation of unprotected acceptors*

## Resumé (abstract in Danish)

Denne afhandling omhandler forskning, som er udført ved Danmarks Tekniske Universitet og Institute for Glycomics i perioden april 2008 – oktober 2011. Afhandlingen består af fire separate emner, som relaterer til metalorganisk kemi og kulhydratkemi.

### Projekt 1: Ultrahurtige Grignard additionsreaktioner i tilstedeværelse af protiske reagenser

Additionen af allylmagnesiumbromid og benzylmagnesiumchlorid til carbonylforbindelser blev studeret i tilstedeværelse af protiske reagenser (f. eks. vand, methanol, ethanol, phenol). I et antal tilfælde og især ved brug af allylmagnesiumbromid blev det observeret, at carbonyladditionen var hurtigere eller sammenlignelig med protoneringen via reagentet.

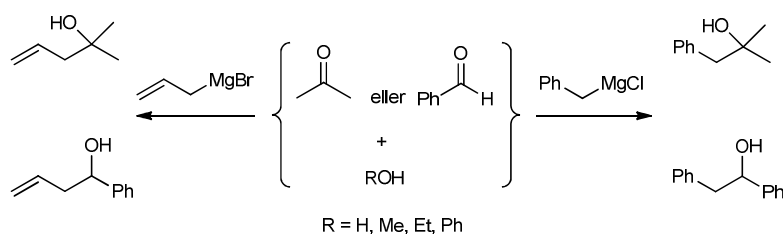

#### *Projekt 1: Konkurrence eksperimenter med Grignard additionsreaktionen*

### Projekt 2: Rutheniumkatalyseret syntese af amider fra primære alkoholer og aminer

Den direkte syntese af amider fra alkoholer og aminer med samtidig frigivelse af brint er tidligere blevet opdaget i Madsengruppen. Yderligere udvikling af reaktionsbetingelserne blev undersøgt, hvorunder støkiometriske additiver og hydrogenacceptorer ikke var nødvendige, og reaktionerne blev katalyseret af ruthenium N-heterocykliske carbenkomplekser. To katalysatorsystemer blev fundet effektive til at fremme amideringen. Disse to systemer viste ingen væsentlige forskelle i reaktivitet, som indikerer at den samme katalytisk aktive forbindelse er i spil.

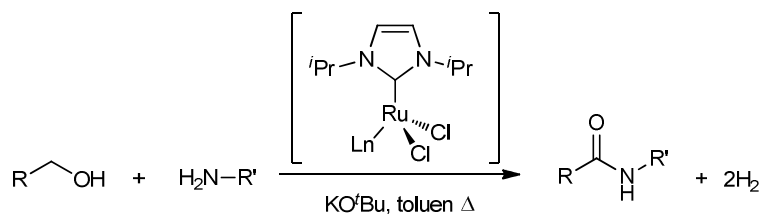

#### *Projekt 2: Amidsyntese katalyseret af N-heterocykliske carbenkomplekser*

### Projekt 3: Syntese af en trisakkaridprobe som formoden denguevirus receptor

Ved Institute for Glycomics har væsentlig forskning været fokuseret på at identificere mulige receptorer for denguevirus (DENV). Baseret på tidligere studier blev GlcNAc $\beta$ 1-3Gal $\beta$ 1-4GlcNAc trisakkaridet overvejet som en mulig virus receptor. Syntesen af trisakkaridproben er blevet gennemført ved kobling af den tilsvarende D-glucosamindonor og lactosaminacceptor efterfulgt af debeskyttelse. De biologiske undersøgelser er på vej.

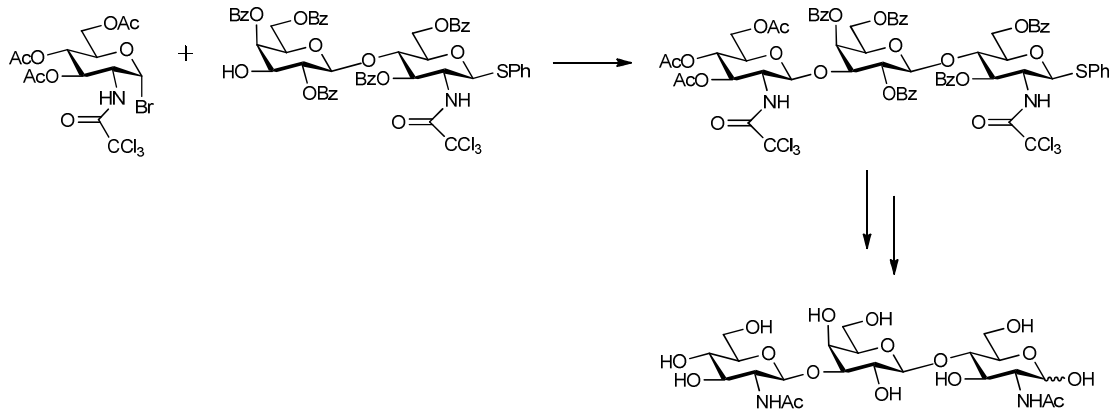

*Projekt 3: Syntese af GlcNAc $\beta$ 1-3Gal $\beta$ 1-4GlcNAc trisakkarid*

### Projekt 4: Glykosylering med ubeskyttede acceptorer

Regioselektiv Koenigs-Knorr glykosylering er blevet studeret med en række ubeskyttede acceptorer ved hjælp af organoborforbindelser, som enten kan aktivere eller blokere *cis*-dioler via esterdannelse. Ved hjælp af phenylborsyre er høj regioselektiv og stereospecifik dannelse af den glykosidiske binding blevet gennemført.

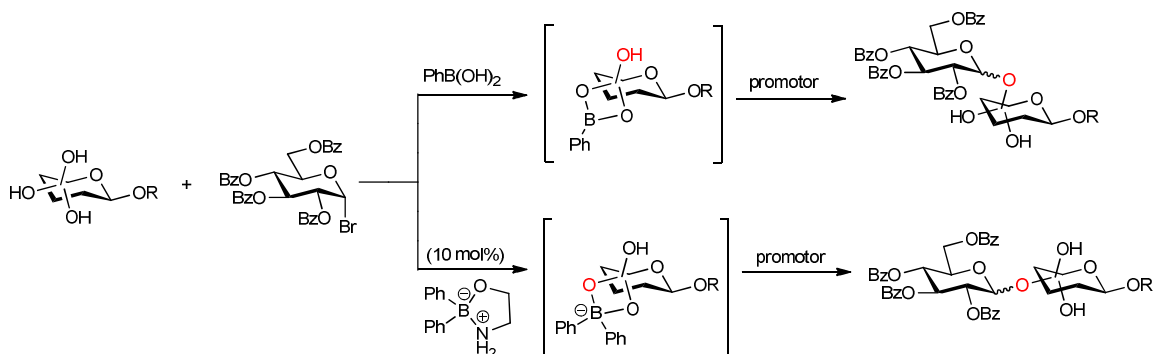

*Projekt 4: Regioselektiv glykosylering af ubeskyttede acceptorer*



## List of abbreviations

Ac	Acetyl	DMTST	Dimethyl-(methylthio)-sulfonium triflate
All	Allyl		
aq.	Aqueous	dppb	1,4-Bis(diphenylphosphino)butane
Ar	Aryl		
atm	Atmosphere	EGP	Envelope glycoprotein
Bn	Benzyl	eq.	Equation
Boc	<i>tert</i> -Butoxycarbonyl	equiv.	Equivalent(s)
Bu	Butyl	Et	Ethyl
Bz	Benzoyl	GAG	Glycosaminoglycan
Cer	Ceramide	Gal	Galactose
CM	Cross metathesis	GC	Gas chromatography
COD	1,5-Cyclooctadiene	GD	Grignard deficiency
COSY	Correlation spectroscopy	Glc	Glucose
Cp*	Pentamethylcyclopentadienyl	GlcA	Glucuronic acid
		GlcNAc	<i>N</i> -Acetylglucosamine
Cy	Cyclohexyl	Glc <sub>p</sub>	Glucopyranosyl
Cyp	Cyclopentyl	H	Heparin
D	Domain	h	Hour(s)
d	doublet (NMR)	HMBC	Heteronuclear multiple-bond correlation
DC	Dendritic cells		
DCC	<i>N,N'</i> -Dicyclohexylcarbodiimide	HS	Heparan Sulfate
DCM	Dichloromethane	HSQC	Heteronuclear single-quantum correlation
DENV	Dengue virus	<i>i</i>	Iso
DMAP	4-(Dimethylamino)pyridine	ICy	1,3-Dicyclohexylimidazol-2-ylidene
DME	1,2-Dimethoxyethane		
DMF	<i>N,N</i> -dimethylformamide	IdoA	Iduronic acid
DMSO	Dimethyl sulfoxide	<i>i</i> Pr	1,3-Di- <i>iso</i> -propylimidazol-2-ylidene

IR	Infrared spectroscopy	ppm	Parts per million
KHMDS	Potassium	Pr	Propyl
	bis(trimethylsilyl)amide	Pyr	Pyridine
LG	Leaving group	rt	Room temperature
<i>m</i>	Meta	s	Singlet (NMR)
M	Molar (mol/l)	sat.	Saturated
m	multiplet (NMR)	SD	Substrate deficiency
Me	Methyl	SET	Single Electron Transfer
Mes	Mesityl	t	Triplet (NMR)
MPh	<i>p</i> -Methoxyphenyl	<i>t, tert</i>	Tertiary
MS	Mass spectrometry	TCA	Trichloroacetyl
M.S.	Molecular sieves	Tf	Trifluoromethanesulfonyl
<i>n</i>	Normal	TFA	Trifluoroacetic acid
NBS	<i>N</i> -Bromosuccinimide	THF	Tetrahydrofuran
NHC	<i>N</i> -Heterocyclic carbene	TLC	Thin layer chromatography
NIS	<i>N</i> -Iodosuccinimide	TMS	Trimethylsilyl
nLc <sub>4</sub>	Lacto- <i>N</i> -neotetraose	tol	Tolyl
NMR	Nuclear magnetic resonance	Trop	5-H-dibenzo[a,d]- cyclohepten-5-yl
<i>o</i>	Ortho		
<i>p</i>	Para	Ts	Toluenesulfonyl; Tosyl
PDC	Pyridinium dichromate	UV	Ultraviolet spectroscopy
Pent	<i>n</i> -Pentenyl	WHO	World Health Organisation
Ph	Phenyl		

## Table of Contents

<b>1. Ultrafast Grignard addition reactions in the presence of protic agents.....</b>	<b>1</b>
<b>1.1. Literature background.....</b>	<b>1</b>
1.1.1. Grignard reagent and the Grignard addition reaction .....	1
1.1.2. Investigation of Barbier-Grignard type reactions in the presence of water .....	3
<b>1.2. Aim of the project .....</b>	<b>7</b>
<b>1.3. Results and discussion .....</b>	<b>8</b>
1.3.1. Competition experiments by adding allylmagnesium bromide .....	8
1.3.2. Competition experiments with benzylmagnesium chloride and butylmagnesium bromide .....	11
1.3.3. Intramolecular competition .....	13
1.3.4. Interpretation.....	17
<b>1.4. Conclusion .....</b>	<b>19</b>
<b>2. Ruthenium catalyzed synthesis of amides from primary alcohols and amines .....</b>	<b>20</b>
<b>2.1. Literature background.....</b>	<b>20</b>
2.1.1. The amide bond.....	20
2.1.2. Amide syntheses catalyzed by metal complexes .....	22
<b>2.2. Aim of the project .....</b>	<b>30</b>
<b>2.3. Results and discussion .....</b>	<b>31</b>
2.3.1. Synthesis and test of a well-defined pre-catalyst.....	31
2.3.2. Study of other pre-catalysts .....	32
2.3.4. Substrate scope.....	35
2.3.5. Tandem reaction with olefin cross metathesis and amidation .....	39
2.3.6. Mechanistic studies .....	42
<b>2.4. Conclusion .....</b>	<b>47</b>
<b>3. Synthesis of a trisaccharide probe as a putative virus receptor and a D-glucuronic acid thioglycoside building block.....</b>	<b>48</b>
<b>3.1. Literature background.....</b>	<b>48</b>
3.1.1. Dengue virus – epidemiology, infection.....	48
3.1.2. Molecular mechanism of infection .....	49

3.1.3. Synthesis of oligosaccharides .....	52
3.1.4. Thioglycosides .....	53
3.1.5. Glycosyl bromides .....	55
<b>3.2. Aim of the project .....</b>	<b>57</b>
<b>3.3. Results and discussion .....</b>	<b>59</b>
3.3.1. Retrosynthetic plan for the GlcNAc $\beta$ (1-3)Gal $\beta$ (1-4)GlcNAc trisaccharide .....	59
3.3.2. Synthesis of the glycosyl donor .....	62
3.3.3. Synthesis of the glycosyl acceptor .....	63
3.3.4. Glycosylation .....	65
3.3.5. Deprotection.....	67
3.3.6. Strategy for the synthesis of heparan sulfate oligosaccharides.....	68
3.3.7. Synthesis of D-glucuronic acid glycosyl donor.....	69
<b>3.4. Conclusion .....</b>	<b>73</b>
<b>4. Glycosylation with unprotected acceptors .....</b>	<b>75</b>
<b>4.1. Methods for glycosylation with unprotected carbohydrates .....</b>	<b>75</b>
<b>4.2. Aim of the project.....</b>	<b>80</b>
<b>4.3. Results and discussion .....</b>	<b>81</b>
4.3.1. Investigating the use of diphenylborinic acid as a catalyst.....	81
4.3.2. Investigating the use of phenylboronic acid as a masking group .....	85
<b>5. Summary .....</b>	<b>91</b>
<b>6. Experimental Section .....</b>	<b>93</b>
<b>6.1. Grignard addition reactions in the presence of protic agents .....</b>	<b>93</b>
<b>6.2. Ruthenium catalyzed synthesis of amides from primary alcohols and amines .....</b>	<b>97</b>
<b>6.3. Synthesis of a trisaccharide probe as a putative virus receptor and a D-glucuronic acid thioglycoside building block .....</b>	<b>110</b>
<b>6.4. Glycosylation with unprotected acceptors .....</b>	<b>126</b>
<b>References .....</b>	<b>135</b>
<b>Appendix - Publications</b>	



# 1. Ultrafast Grignard addition reactions in the presence of protic agents

## 1.1. Literature background

### 1.1.1. Grignard reagent and the Grignard addition reaction

In 1899 Barbier reported a one-pot coupling reaction between a carbonyl compound and an alkyl halide mediated by magnesium metal.<sup>1</sup> His student Victor Grignard turned the reaction into a more practical two step protocol by preparing the organometallic reagent prior to the addition reaction.<sup>2</sup> This discovery changed the course of organic chemistry and earned him the Nobel Prize in 1912.

The Grignard reaction was actually the first practical organometallic transformation to be discovered for forming a carbon-carbon bond.<sup>3</sup> Today, alkyl- and aryl magnesium halides are known as Grignard reagents and are synthesized by the direct reaction of magnesium with alkyl- or aryl halides.<sup>4</sup> The Grignard reagent does not react with ether type solvents, and as a result anhydrous diethyl ether and tetrahydrofuran are widely used as solvents. The magnesium center of the Grignard reagent can coordinate typically two molecules of diethyl ether or THF, although in high concentrated solution even more than 2 molecules of ether can be coordinated.<sup>5</sup> The solid-state molecular structure of the ethylmagnesium bromide bis(diethyl etherate) (**1**) was first determined by Guggenberger and Rundle in 1964 by an X-ray diffraction study (Figure 1).<sup>6</sup> The  $C_2H_5MgBr \cdot [(C_2H_5)_2O]_2$  crystals were isolated from a diethyl ether solution of an EtBr/Mg reaction mixture by slow cooling with a stream of cold nitrogen gas.<sup>7</sup> There are further reports in the literature, where the structure of other Grignard reagents have been identified by single crystal X-ray diffraction techniques.<sup>8,9</sup>

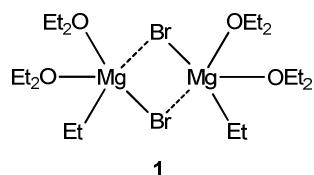

**Figure 1** Proposed structure of  $C_2H_5MgBr \cdot [(C_2H_5)_2O]_2$

But in fact, the structure of Grignard reagents in ether solution are more complicated than this simple formula suggests. Wilhelm Schlenk and his son discovered that more than one magnesium containing species exist in the diethyl ether solution of a Grignard reagent.<sup>10</sup> The Schlenk equation describes that a Grignard reagent in solution exists in a dynamic equilibrium between the alkylmagnesium halide, dialkylmagnesium and the magnesium halide (Scheme 1).



**Scheme 1** The Schlenk equilibrium

The first direct evidence for the Schlenk equilibrium was reported by Ashby *et al.* by means of <sup>1</sup>H-NMR spectroscopic measurements of the solutions of methylmagnesium bromide (CH<sub>3</sub>MgBr) in diethyl ether at -105 °C, where characteristic signals for both structures were measured.<sup>11</sup> Comparable evidence was also obtained when *tert*-butylmagnesium chloride in diethyl ether was studied.<sup>12</sup> The position of the equilibrium can be influenced by the solvent, the temperature, and the nature of the various substituents. For example, by adding dioxane the dihalide MgX<sub>2</sub> species precipitates from the solution, and the equilibrium is completely driven to the right side.<sup>13</sup> Moreover, a thorough study of the association factors of various Grignard reagents in diethyl ether and THF found that monomeric, dimeric and higher oligomeric species are present depending on the solvent, the halogen and the organic substituents on the magnesium atom.<sup>14</sup>

Consequently, there are many factors that influence the structure of a Grignard reagent in an ethereal solution:

- The Lewis basicity and steric properties of the ether solvent
- The electronegativity and size of the halogen atom
- The nature and steric properties of the organic substituent on the magnesium atom

However, in most applications of Grignard reagents in synthetic chemistry it appears coherent to use the simple RMgX formula to describe the reaction mechanism.

Due to the polarity of the carbon-magnesium bond ( $C^{\delta-}-Mg^{\delta+}$ ) the Grignard reagents act typically as nucleophiles and attack electrophilic carbon atoms during the Grignard addition reaction (e.g. in aldehydes, ketones, esters or nitriles). However, sterically hindered substrates may react according to a SET (Single Electron Transfer) mechanism.<sup>15</sup> Notably, the reaction often proceeds through a concerted nucleophilic addition mechanism (Scheme 2).

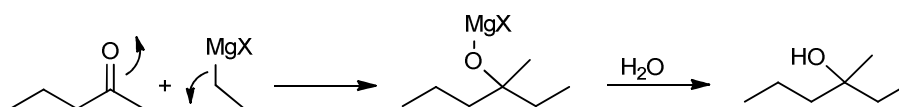

**Scheme 2** Concerted nucleophilic addition mechanism of the Grignard reaction

In the Grignard addition reaction the absence of water is crucial, since the Grignard reagent would otherwise react rapidly to produce the corresponding alkanes. Nevertheless, the stepwise protocol became one of the most important methods in organic chemistry to form carbon-carbon bonds.

### 1.1.2. Investigation of Barbier-Grignard type reactions in the presence of water

Recently, the one-pot Barbier procedure has gained renewed interest, especially for the coupling of more reactive allyl halides. Contrary to the Grignard addition reaction the Barbier procedure does not require strictly anhydrous solvents and can be performed very effectively in aqueous media. In fact, the allylation of aldehydes and ketones usually occurs faster under the Barbier conditions and gives rise to higher yields when water is used as a (co)solvent.<sup>16</sup> Moreover, a number of metals (e.g. zinc, tin, bismuth, indium, antimony, manganese) have been introduced to mediate the Barbier-type reaction.<sup>17-20</sup> Among these, the most widely used metals are zinc and indium.<sup>16,17</sup>

Whitesides *et al.* reported an efficient tin- and indium-mediated allylation of unprotected carbohydrates in aqueous media.<sup>21</sup> The Barbier type reaction takes place in aqueous ethanol by the use of tin or indium metal. The reaction occurs with 1,2-chelation control to afford the 1,2-*threo* isomer as the major product (Scheme 3).



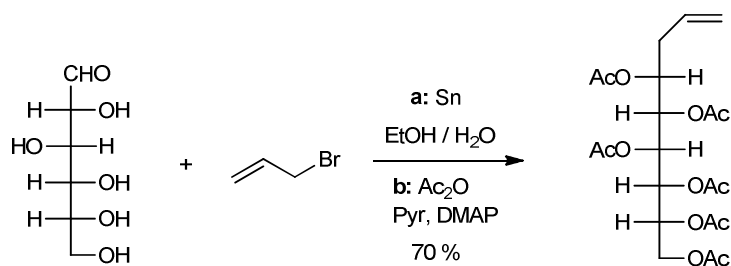

**Scheme 3** Alkylation of unprotected carbohydrates in aqueous media

Lately, Zhang and Li studied the classical Barbier reaction in water with magnesium metal.<sup>22</sup> The allyl halide was reacted with benzaldehyde in the presence of magnesium in different aqueous solvent systems (Scheme 4). Surprisingly, using 0.1 N HCl or 0.1 N NH<sub>4</sub>Cl solutions as the reaction solvent resulted in a quantitative conversion of the aldehyde, generating a mixture of the allylation and the pinacol coupling products. Subsequently, a variety of aldehydes were tested with this allylation method. Several aromatic aldehydes were allylated efficiently by allyl halides and magnesium in aqueous 0.1 N NH<sub>4</sub>Cl. However, aliphatic aldehydes were inert under the same reaction conditions. This result was attributed to the difference in reduction potentials between aliphatic and aromatic aldehydes.<sup>23</sup>

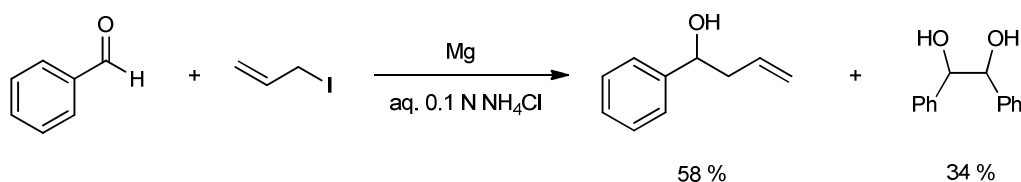

**Scheme 4** Magnesium-mediated Barbier-type allylation of aldehydes in aqueous media

In spite of many examples for applications of efficient Barbier-type reactions in aqueous media, it was not completely understood whether the mechanism follows a radical pathway or proceeds via a discrete allylmetal species. To this end, Madsen *et al.* reported a mechanistic study of the Barbier allylation of benzaldehyde derivatives with six different metals (Zn, In, Sb, Sn, Bi and Mg) in aqueous media.<sup>24</sup> It was found that all metals except magnesium form a discrete allylmetal species and the rate-determining step is the polar addition to the carbonyl group through a Zimmermann-Traxler transition state, while for

magnesium the turnover-limiting step is the generation of the radical anion of the benzaldehyde (Scheme 5).

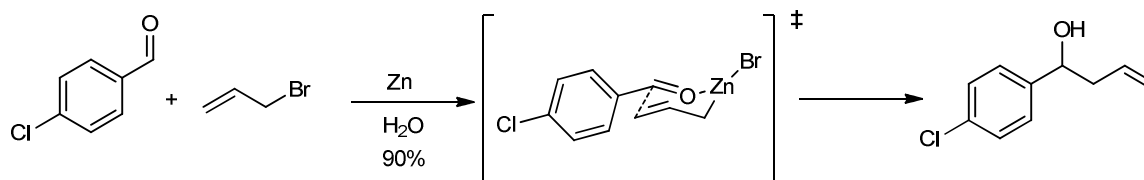

**Scheme 5** Mechanistic study of the Barbier-type allylation

However, some of the reactive intermediates are difficult to observe by experiments in a finite time in aqueous media. Therefore, quantum mechanical calculations have been carried out by Chung *et al.* for the reactions of a series of monomeric allylmetals with water and carbonyl compounds in the gas phase.<sup>25</sup> Based on the calculated structures of various allylmetal complexes these were separated into two major groups ( $\pi$ -allylmetal and  $\sigma$ -allylmetal complexes) (Figure 2). According to the calculated kinetic preferences, the two groups were divided into three subclasses (**A**, **B** and **C**). Class **A** consists of very reactive  $\pi$ -allylmetal complexes ( $M = K, Rb, CaBr, SrBr$  and  $BaBr$ ) which are highly ionic and hydrolyze much faster than they undergo allylation. Class **B** is made up of some  $\pi$ -complexes ( $Li, Na, Ga(I), In(I), Tl(I), Sn^{II}Br$  and  $Pb^{II}Br$ ) and polarized  $\sigma$ -complexes ( $BeBr, MgBr, Si^{II}Br$  and  $Ge^{II}Br$ ). These allylmetals are less polarized than the class **A** complexes and they may hydrolyze or allylate depending on the experimental conditions. The class **C** complexes (the rest of the  $\sigma$ -allylmetals) preferentially undergo allylation. However, the organometallic reaction in aqueous solution is more complicated. The effects of ligands, the explicit water solvent and aggregation on the intrinsic kinetic preference must also be considered.

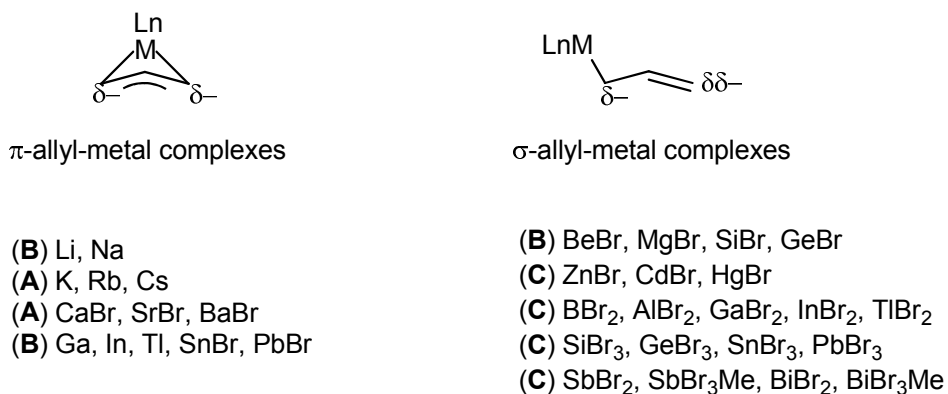

**Figure 2** Classification of allylmetal complexes

Torkil Holm has measured the reaction rates of various Grignard reagents with different ketones and aldehydes.<sup>26</sup> A series of competition experiments was performed using allylmagnesium bromide and benzylmagnesium bromide competing for the carbonyl compound at very dilute concentration. In all experiments the allylic addition product dominated and only trace amounts of the benzylic adduct was observed. Surprisingly, even at a ratio of allyl : benzyl = 1 : 128 the allylic product accounted for 97% of the product. The competition kinetics also indicated that the allyl Grignard reagent adds  $1.5 \times 10^5$  times faster than the corresponding butyl reagent. Furthermore, the reaction rates for several carbonyl compounds (e.g. benzophenone, acetone, benzaldehyde) did not differ significantly. The extremely reactive allylmagnesium bromide was suggested to react at a rate which is near the diffusion controlled maximum. In fact, the addition of the allylmagnesium bromide does not take place via the classical four-membered transition state but via a six-center cyclic concerted process (Scheme 6).<sup>27</sup>

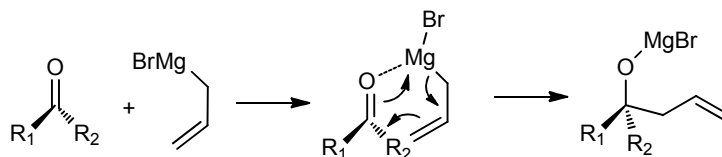

**Scheme 6** Addition of allylmagnesium bromide to a carbonyl compound

## 1.2. Aim of the project

A number of studies have reported that various metals such as zinc, tin, indium and magnesium can mediate Barbier-type allylation reactions effectively in aqueous media.<sup>16,28-30</sup> For several metals it is believed that a discrete allylated species is formed and the mechanism involves a rate-determining polar addition to the carbonyl moiety.<sup>24</sup> However, for magnesium it is not completely clear whether the corresponding allylmagnesium halide is actually formed. Surprisingly, quantum mechanical calculations suggested similar activation energies towards addition and protonation for the reaction of allylmagnesium bromide with acetone and water.<sup>25</sup> In addition, it has been proven that the addition reaction of allylmagnesium bromide is extremely fast<sup>26</sup> and it may therefore be able to compete with the protonation by a protic (co)solvent such as water.

However, classical Grignard addition reactions have never been carried out efficiently in the presence of water. Based on the observations described above we decided to compare the rate of addition to the rate of protonation for several Grignard reagents, especially allyl Grignard type reagents.

## 1.3. Results and discussion

### 1.3.1. Competition experiments by adding allylmagnesium bromide

Measuring competition kinetics is widely used to estimate reactivities of different Grignard reagents.<sup>26,31</sup> In this regard two powerful tools are the substrate deficiency (SD) experiment and the Grignard deficiency (GD) experiment. The SD experiment is carried out by adding a very low concentration of a substrate to a large excess of two competing Grignard reagents, while the GD experiment is performed by the addition of a small concentration of Grignard reagent to an excess of the competing substrates. Therefore, we decided to apply the GD competition experiments to study the reactivity of some Grignard reagents towards addition and protonation.

First, a 0.1 M ethereal solution of allylmagnesium bromide was reacted with an equimolar mixture of acetone and water in diethyl ether. Surprisingly, the yield of the addition product was found to be around 90% by GC (Table 1, entry 1). A similar observation was obtained using a more diluted Grignard solution (Table 1, entry 2). This unexpected result indicated that the addition reaction to acetone should be much faster than the reaction with water. Thus, the investigation was widened to study allylmagnesium bromide reacting with a number of protic reagents (Table 1). Accordingly, allylmagnesium bromide was reacted with acetone in the presence of methanol, ethanol and benzoic acid (equimolar to acetone). The yield of the addition products were in the 52 - 63% range indicating a higher degree of protonation as compared to water (entries 3-5). In another experiment, the allyl Grignard reagent showed slightly less reactivity towards benzaldehyde than acetone. The competition between benzaldehyde and water resulted in the addition product in 75 % yield (entry 6) while using methanol, phenol or benzoic acid gave 42-63 % yields (entries 7-10). Methyl benzoate, acetophenone and *p*-methoxybenzaldehyde furnished moderate yields of the addition product in competition with water, methanol and phenol (entries 11-15). With methyl benzoate only double addition was observed to afford the tertiary alcohol, while the ketone intermediate was not detected. The reaction of allylmagnesium bromide with valerolactone and water afforded the double addition product in a very low yield (entry 16).

**Table 1** Competitive reaction of allylmagnesium bromide with carbonyl compounds and protic compounds

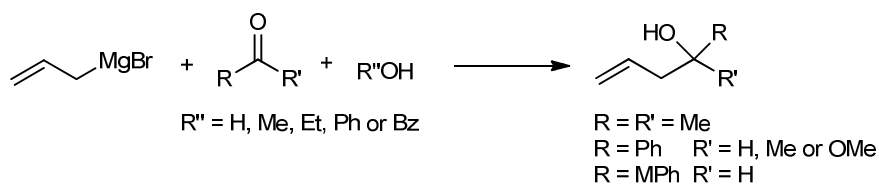

Entry	Allylmagnesium bromide	Carbonyl Compound (0.6 M)	Protic Compound (0.6 M)	GC Yield <sup>a</sup> [%]
1	0.1 M	acetone	H <sub>2</sub> O	91
2	0.01 M	acetone	H <sub>2</sub> O	90
3	0.1 M	acetone	MeOH	56
4	0.1 M	acetone	EtOH	63
5	0.1 M	acetone <sup>c</sup>	benzoic acid <sup>c</sup>	52
6	0.1 M	benzaldehyde	H <sub>2</sub> O	75 (73) <sup>b</sup>
7	0.25 M	benzaldehyde	MeOH	53
8	0.1 M	benzaldehyde <sup>c</sup>	MeOH <sup>c</sup>	42
9	0.16 M	benzaldehyde <sup>d</sup>	phenol <sup>d</sup>	43
10	0.1 M	benzaldehyde	benzoic acid	63
11	0.16 M	methyl benzoate	H <sub>2</sub> O	56
12	0.16 M	methyl benzoate	MeOH	40
13	0.16 M	methyl benzoate	phenol	47
14	0.16 M	acetophenone	phenol	31
15	0.1 M	<i>p</i> -methoxybenzaldehyde	phenol	35 (29) <sup>b</sup>
16	0.1 M	valerolactone	H <sub>2</sub> O	12 (8) <sup>b</sup>

<sup>a</sup> Based on Grignard reagent and determined using octane as internal standard

<sup>b</sup> Isolated yield

<sup>c</sup> 0.34 M

<sup>d</sup> 0.5 M

<sup>e</sup> 0.3 M

Due to the unexpected result in the competition between acetone and water, the addition of allylmagnesium bromide to acetone was further investigated using excess of the protic reagents (Table 2). Now the allylmagnesium bromide solution was added to the pure mixture of acetone and water (1:1) and the addition product was detected in 92% yield (entry 1). A

similar result was observed with the ratio of acetone : water = 1:2 (entry 2). When the Grignard reagent was added to the mixture of acetone : water = 1:4 the addition product accounted for 81% yield (entry 3). Surprisingly, the use of 21 equivalents of water still resulted in the desired product in 66% yield (entry 4), and even a 1:42 mixture of acetone and water afforded the carbonyl addition in 25% yield (entry 5). The mixture of acetone and methanol (1:1, 1:2) furnished a slightly higher yield than the ether solution of the two substrates (entries 6 and 7). The same effect was noticed by having acetone / ethanol (1:1, 1:2) mixtures (entries 8 and 9).

**Table 2** Competitive reaction of allylmagnesium bromide with a pure mixture of acetone and protic compound

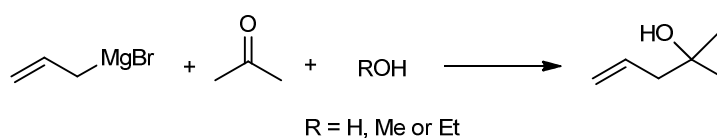

Entry	Grignard Reagent (0.1 M)	Mixture of Carbonyl and Protic Compounds	GC Yield <sup>a</sup> [%]
1	allylmagnesium bromide	acetone / H <sub>2</sub> O (1:1)	92
2	allylmagnesium bromide	acetone / H <sub>2</sub> O (1:2)	93
3	allylmagnesium bromide	acetone / H <sub>2</sub> O (1:4)	81
4	allylmagnesium bromide	acetone / H <sub>2</sub> O (1:21)	66
5	allylmagnesium bromide	acetone / H <sub>2</sub> O (1:42)	25
6	allylmagnesium bromide	acetone / MeOH (1:1)	74
7	allylmagnesium bromide	acetone / MeOH (1:2)	56
8	allylmagnesium bromide	acetone / EtOH (1:1)	68
9	allylmagnesium bromide	acetone / EtOH (1:2)	46

<sup>a</sup> Based on Grignard reagent and determined using octane as internal standard

From these experiments it can be concluded that the addition of the allylmagnesium bromide to acetone or benzaldehyde is faster than the protonation by the protic compound, independent of the presence of ether. However, with other types of carbonyl compounds such as *p*-anisaldehyde, methyl benzoate and acetophenone the protonation was found to dominate.

### 1.3.2. Competition experiments with benzylmagnesium chloride and butylmagnesium bromide

It has been shown that the relative reactivity of allyl Grignard reagents towards acetone is > 3000 times higher as compared to benzyl Grignard reagents.<sup>26</sup> Although the benzyl Grignard reagent is less reactive than the allyl Grignard we decided to carry out competition experiments with benzylmagnesium chloride in diethyl ether (Table 3).

We observed that benzylmagnesium chloride also reacted sufficiently fast with acetone in the presence of water (entry 1). Surprisingly, under competition with water protonation, the benzylmagnesium chloride addition to benzaldehyde was more effective than addition to acetone (entry 2). Preferred reactivity towards benzaldehyde was also observed in the presence of methanol and ethanol (entries 3 and 4). Competition between benzaldehyde and phenol gave the addition product in only 29 % yield (entry 5). Although the allyl Grignard reagent is known to add ca.  $1.5 \times 10^5$  faster than the corresponding butyl reagent<sup>26</sup> the reaction of butylmagnesium bromide with acetone or benzaldehyde in the competition with water was included in the study. The butyl Grignard, as anticipated, yielded only trace amounts of the addition products (entries 7 and 8). This indicates that butylmagnesium bromide reacts much slower and it undergoes complete protonation in the competition with carbonyl addition.



**Table 3** Competition reaction between carbonyl compounds and protic compounds for Grignard reagents

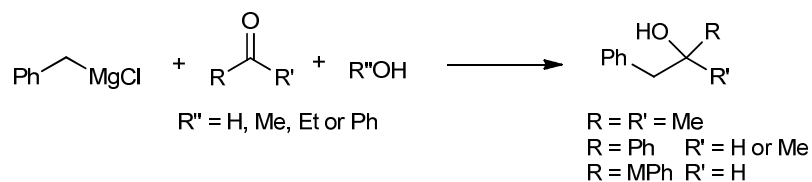

Entry	Grignard Reagent (0.1 M)	Carbonyl Compound (0.6 M)	Protic Compound (0.6 M)	GC Yield <sup>a</sup> [%]
1	benzylmagnesium chloride	acetone	H <sub>2</sub> O	30
2	benzylmagnesium chloride	benzaldehyde	H <sub>2</sub> O	89
3	benzylmagnesium chloride	benzaldehyde	MeOH	63
4	benzylmagnesium chloride	benzaldehyde	EtOH	46
5	benzylmagnesium chloride	benzaldehyde	phenol	29
6	benzylmagnesium chloride	<i>p</i> -methoxybenzaldehyde <sup>b</sup>	phenol <sup>b</sup>	18
7	butylmagnesium bromide	acetone	H <sub>2</sub> O	2
8	butylmagnesium bromide	benzaldehyde	MeOH	0

<sup>a</sup>Based on Grignard reagent and determined using octane as internal standard

<sup>b</sup> 0.2 M

The observed reactivities in acetone-water mixtures can be rationalized by the different reactivities of the three Grignard reagents: allylmagnesium bromide >> benzylmagnesium chloride >> butylmagnesium bromide. For allylmagnesium bromide the half-time for addition to acetone has been established to be around one  $\mu\text{s}$ .<sup>26</sup> Although there is no value reported for benzylmagnesium chloride, it can be estimated from the reported rate constant for benzylmagnesium bromide. A 10 fold rate increase has been estimated when comparing the bromide to the chloride.<sup>32</sup> Based on this, the half-time for addition of benzylmagnesium bromide is estimated to be around one ms. For butylmagnesium bromide the half-time for the addition to acetone is reported to be almost one second.<sup>33</sup> In conclusion, there is roughly a factor of 1000 for the reactivity between each of the allyl, benzyl and butyl reagents. Thus, in the case of the extremely reactive allylmagnesium bromide the addition can compete

efficiently with protonation while for the less reactive Grignard reagents the protonation becomes the predominant reaction.

### 1.3.3. Intramolecular competition

It has been reported that both SD and GD competition experiments can give misleading results when using Grignard reagents, even with rather slow reactions.<sup>26,31</sup> This has been explained by the effect that when the solutions get in contact a “meeting zone” is formed where the more reactive competitive agent gets depleted locally.<sup>34</sup> Therefore, the less reactive competitive agent gets a better chance to react with the substrate. In the case of a Grignard reagent meeting a mixture of acetone-water, and assuming that water is the more reactive competitive agent, the water molecules can be removed by the Grignard reagent leaving a local excess of acetone in a dry diethyl ether zone. Thus, in this zone the less reactive acetone can now be attacked by the Grignard reagent. It is practically impossible to predict the importance of this local “depletion” or “scavenging effect” since it depends on the concentrations, the way of mixing and the nature of the reaction products.

The scavenging effect can be almost completely avoided by presenting the two competing functional groups in the same molecule. Thus, in an intramolecular competition the two functional groups have the same local concentration and thus have identical chances to react with the Grignard reagent. The measured ratio of products depends exclusively on reactivity.

Consequently, a series of experiments were carried out in which the Grignard reagent was reacted with bifunctional substrates containing both a hydroxyl group and a carbonyl group (Table 4). Allylmagnesium bromide was added to *m*-hydroxybenzaldehyde and the addition product was observed in 30% yield (entry 1). When the allyl Grignard was reacted with a mixture of *p*-methoxybenzaldehyde and phenol, the addition/protonation ratio was 35:65 (Table 1, entry 15), while adding the same reagent to *p*-hydroxybenzaldehyde the ratio was 5:95 (Table 4, entry 3). The intramolecular competition with other hydroxyl-carbonyl compounds also resulted in low yields of the addition product (entries 4-6). When benzylmagnesium chloride was added to a mixture of *p*-methoxybenzaldehyde and phenol, the addition/protonation ratio was 18:82 (Table 3, entry 6), while with *p*-hydroxybenzaldehyde as the substrate no addition product was detected (Table 4, entry 7).

The reaction with *m*-hydroxybenzaldehyde and with *p*-hydroxyacetophenone did not give any addition products either (entries 8 and 9). This indicates that the rate of the protonation of benzylmagnesium chloride by the hydroxyl group is more than hundred times faster than the addition to the aldehyde.

**Table 4** Reaction of Grignard reagents with carbonyl compounds containing a hydroxyl group

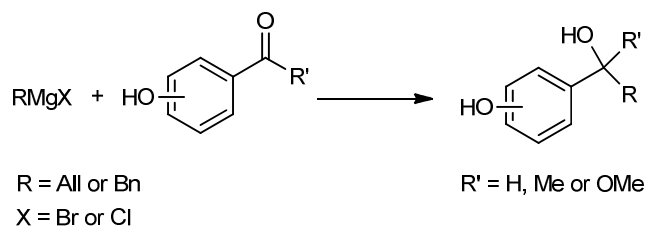

Entry	Grignard Reagent	Bifunctional Compound	GC Yield <sup>a</sup> [%]
1	allylmagnesium bromide (0.16 M)	<i>m</i> -hydroxybenzaldehyde (0.3 M)	30 (26) <sup>b</sup>
2	allylmagnesium bromide (0.25 M)	<i>m</i> -hydroxybenzaldehyde (0.6 M)	23
3	allylmagnesium bromide (0.16 M)	<i>p</i> -hydroxybenzaldehyde (0.3 M)	5
4	allylmagnesium bromide (0.16 M)	<i>o</i> -hydroxybenzaldehyde (0.3 M)	0
5	allylmagnesium bromide (0.16 M)	<i>p</i> -hydroxyacetophenone (0.3 M)	13
6	allylmagnesium bromide (0.16 M)	methyl <i>p</i> -hydroxybenzoate (0.3 M)	2
7	benzylmagnesium chloride (0.1 M)	<i>p</i> -hydroxybenzaldehyde (0.4 M)	0
8	benzylmagnesium chloride (0.1 M)	<i>m</i> -hydroxybenzaldehyde (0.4 M)	0
9	benzylmagnesium chloride (0.1 M)	<i>p</i> -hydroxyacetophenone (0.4 M)	0

<sup>a</sup>Based on Grignard reagent and determined using octane as internal standard

<sup>b</sup>Isolated yield

Remarkably, in the reaction of allylmagnesium bromide with *m*-hydroxybenzaldehyde a 30% yield of the addition product was observed while the reaction with *p*-hydroxybenzaldehyde resulted in only 5% yield. This pronounced difference in the reactivity of the two benzaldehyde derivatives can be explained by the Hammett equation.<sup>35</sup> The resonance forms show that the hydroxyl group at the *para* position has a positive mesomeric effect (+M) which decreases the electrophilicity of the carbon atom of the aldehyde group (Scheme 7). According to the Hammett equation a *p*-hydroxyl group is electron donating while a *m*-hydroxyl group is electron withdrawing. Thus, the *p*-hydroxybenzaldehyde is more stable and less reactive in a nucleophilic addition than the *meta* derivative.

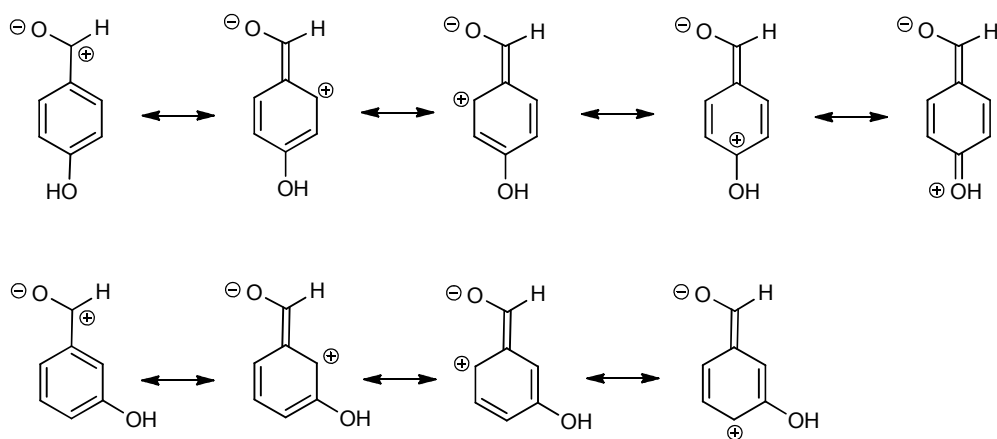

**Scheme 7** Resonance forms of *p*- and *m*-hydroxybenzaldehyde

Similar results were obtained with benzoic acid and octanoic acid, which can also react with the Grignard reagent in two different ways. In this case, we studied not the intramolecular completion between two functional groups, but two different reactivities of the same functional group. As shown in Table 5 the concentrations of the Grignard reagents and the carboxylic acid solution slightly affected the addition/protonation ratio (Table 5). The reaction of 0.2 M allylmagnesium bromide with 0.2 M benzoic acid solution resulted in 23% yield of the addition product (entry 1), while 0.4 M and 0.6 M solutions afforded 20% and 14% of the tertiary alcohol (entries 2 and 3). The intramolecular competition with octanoic acid gave very low yield (entry 4). When benzylmagnesium chloride was reacted with benzoic acid no addition was observed (entry 5). It should be noted that only the double

addition was observed to afford the corresponding tertiary alcohol, and the intermediate ketone was never detected.

**Table 5** Reaction of Grignard reagents with benzoic acid and octanoic acid

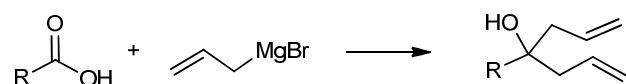

Entry	Grignard Reagent	Bifunctional Compound	GC Yield <sup>a</sup> [%]
1	allylmagnesium bromide (0.2 M)	benzoic acid (0.2 M)	23 (21) <sup>b</sup>
2	allylmagnesium bromide (0.2 M)	benzoic acid (0.4 M)	20
3	allylmagnesium bromide (0.2 M)	benzoic acid (0.6 M)	14
4	allylmagnesium bromide (0.1 M)	octanoic acid (0.25 M)	9
5	benzylmagnesium chloride (0.1 M)	benzoic acid (0.2 M)	0

<sup>a</sup>Based on Grignard reagent and determined using octane as internal standard

<sup>b</sup>Isolated yield

Notably, a higher ratio towards protonation was obtained for the benzoic acid as compared to *m*-hydroxybenzaldehyde. Using *m*-hydroxybenzaldehyde the addition/protonation ratio was 23:77 (Table 4, entry 2), while with benzoic acid the ratio was 14:86 (Table 5, entry 3). This observation can be explained by the higher acidity of the proton in benzoic acid or/and the higher reactivity of the carbonyl group in benzaldehyde.

Since an oxygen-hydrogen bond is broken in the protonation reaction a primary deuterium isotope effect might be expected. However, experiments with the reaction between allylmagnesium bromide and deuterated benzoic acid and octanoic acid showed no significant changes in the product distributions from those obtained with the non-deuterated acids. The ultrafast reactions most likely have early transition states in which case the  $k_H/k_D$  will be ~ 1.0.

Initially, one of the driving forces behind these investigations was the idea to allylate unprotected carbohydrates (i.e. gluconolactone) effectively using this chemistry. However,

due to the presence of the hydroxyl groups, acting as intramolecular protonation agents, the starting material was typically recovered quantitatively.

#### 1.3.4. Interpretation

It is puzzling that the intermolecular competition gives higher degree of addition vs. protonation than the intramolecular competition and the reason may lie in the nature of the experiment. As already described a Grignard reagent is a combination of an alkylmagnesium halide, dialkylmagnesium and a magnesium halide in a Lewis donor solvent (Schlenk equilibrium) (Scheme 8).

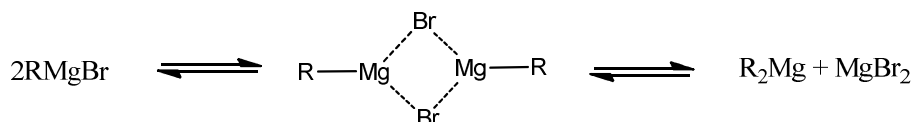

**Scheme 8** Schlenk equilibrium

The ligands around magnesium exchange rapidly and the position of the Schlenk equilibrium is shifted differently in weakly or strongly donating solvents. A shift in the position of the Schlenk equilibrium is a result of the differences in the Lewis acidity of the various components which increase in the order:  $\text{R}_2\text{Mg} \ll \text{RMgBr} < \text{MgBr}_2$ . Even though the Schlenk equilibrium is fast, it is still measurable. The rate of the ligand exchange around the individual magnesium atoms must be assumed to be diffusion controlled. In addition, the complexation energy of one water molecule to allylmagnesium bromide has been calculated to  $-23.1 \text{ kcal/mol}$ .<sup>25</sup> This reflects the strong Lewis acidity of the metal in the Grignard reagent.

Based on the aforementioned considerations in the reaction of Grignard reagents with a mixture of a carbonyl substrate and a protic compound, the addition can be more favored than the protonation if the reagent is extremely reactive like allylmagnesium bromide. Furthermore, the degree of protonation may decrease by coordinating water to any electrophilic magnesium compound including magnesium bromide. Therefore, it was decided to repeat some of the competition experiments with extra magnesium bromide added. When 0.1 M allylmagnesium bromide solution was mixed with one equivalent of  $\text{MgBr}_2$  and then reacted with the mixture of acetone and water in ether solution, the yield of the addition was

quantitative. This is a pronounced increase compared to the 91% yield in Table 1, entry 1. In addition, when allylmagnesium bromide with one equivalent of  $\text{MgBr}_2$  was added to the solution of benzaldehyde and water 85% yield of the addition product was observed which should be compared to the 75% yield in the Table 1, entry 6. This demonstrates that  $\text{MgBr}_2$  can influence the yield of the addition. It should be noted that before adding extra  $\text{MgBr}_2$  the concentration of the  $\text{MgBr}_2$  was already high in the Grignard solution and this can explain the slight increase of the yields. Thus, a 0.1 M allylmagnesium bromide solution containing 20% excess  $\text{MgBr}_2$  (compared to  $\text{RMgX}$ ) was prepared and mixed with the mixture of acetone/water (1:1) in ether solution to afford 56% addition and 44% protonation, while containing 100% extra  $\text{MgBr}_2$  gave nearly quantitative addition.

This confirms that magnesium compounds may serve as water scavengers to a great extent in fast Grignard addition reactions. In the case of the less reactive Grignard reagents like butylmagnesium bromide the protonation is faster than the addition even though water or the alcohol is coordinated to magnesium and have reduced reactivity.

## 1.4. Conclusion

In all experiments reported here the Grignard reagents were added to an excess of the competing substrates (inverse addition). When carbonyl and protic compounds were competing for the added Grignard reagent, rather high yields of the addition products were observed (intermolecular competition). Especially allylmagnesium bromide afforded a high degree of carbonyl addition, although also benzylmagnesium chloride was competitive to some extent. However, butylmagnesium bromide did not undergo carbonyl addition in the presence of a protic reagent.

In intramolecular competitions, in which the substrates contain both a carbonyl and a hydroxyl group only allylmagnesium bromide was able to form the addition product in low to moderate yield. For benzylmagnesium chloride and butylmagnesium bromide the protonation was exceedingly faster than the addition to the carbonyl group.

These contrasting outcomes can be explained by a scavenging effect. In the intermolecular competition the electrophilic magnesium compounds can coordinate with water or other protic compounds. Thus, the carbonyl group is left free to react with the Grignard reagent. When alcohols are used as competitors the higher degree of protonation can be accounted for by less efficient complexation of alcohols to magnesium. Although in the intramolecular competition the scavenging effect is nearly absent, it has been shown that the rate of the addition to carbonyl groups can still compare with the rate of protonation in the addition of the extremely reactive allylmagnesium bromide.



## 2. Ruthenium catalyzed synthesis of amides from primary alcohols and amines

### 2.1. Literature background

#### 2.1.1. The amide bond

The amide bond is one of the most important linkages in the organic chemistry of life. It is the key functional group in peptides and proteins and the peptide bond is essential for all living organisms. Amide formation is also fundamental for several polymers and the linkage is also often found in pharmaceuticals and natural products.<sup>36-38</sup> Thus, it is not surprising that numerous methods have been developed for the generation of amides.<sup>39</sup> Most frequently, amide synthesis is based on the condensation reaction between a carboxylic acid and an amine under formation of one molecule of water. In this case, the carboxylic acid must be activated *in situ* by a coupling reagent. Carbodiimides such as *N,N'*-dicyclohexylcarbodiimide (DCC) are dehydrating agents, and therefore they are often used to activate carboxylic acids toward amide formation (Scheme 9, pathway a). Alternatively, the carboxylic acid can be converted into a more reactive derivative (e.g. an acid chloride or an anhydride) (Scheme 9, pathway b).

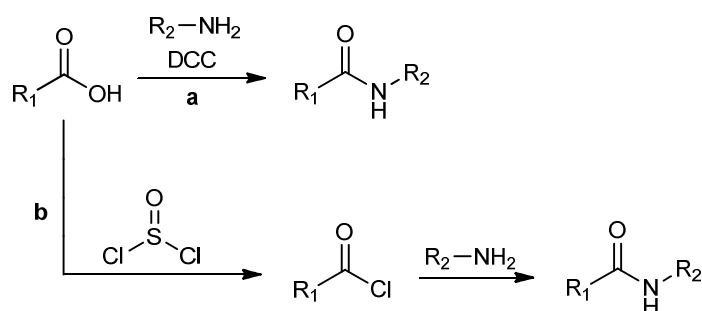

**Scheme 9** Amide synthesis by DCC coupling reagent *in situ* (a) and via acid chloride (b)

There are several other common procedures for the synthesis of amides (Scheme 10). The Beckmann rearrangement is an acid-catalyzed rearrangement of an oxime to an amide.<sup>40,41</sup> The Staudinger ligation also provides a way to form an amide bond between an

azide and an appropriately substituted triaryl phosphine.<sup>42,43</sup> In addition, nitriles can be transformed into amides in the presence of a strong acid by the Ritter reaction.<sup>44</sup> Furthermore, the coupling of  $\alpha$ -ketoacids and hydroxylamines,<sup>45</sup> amidation of ketones (Schmidt)<sup>46</sup> and thioacids with azides<sup>47</sup> are also valuable tools for amide formation.

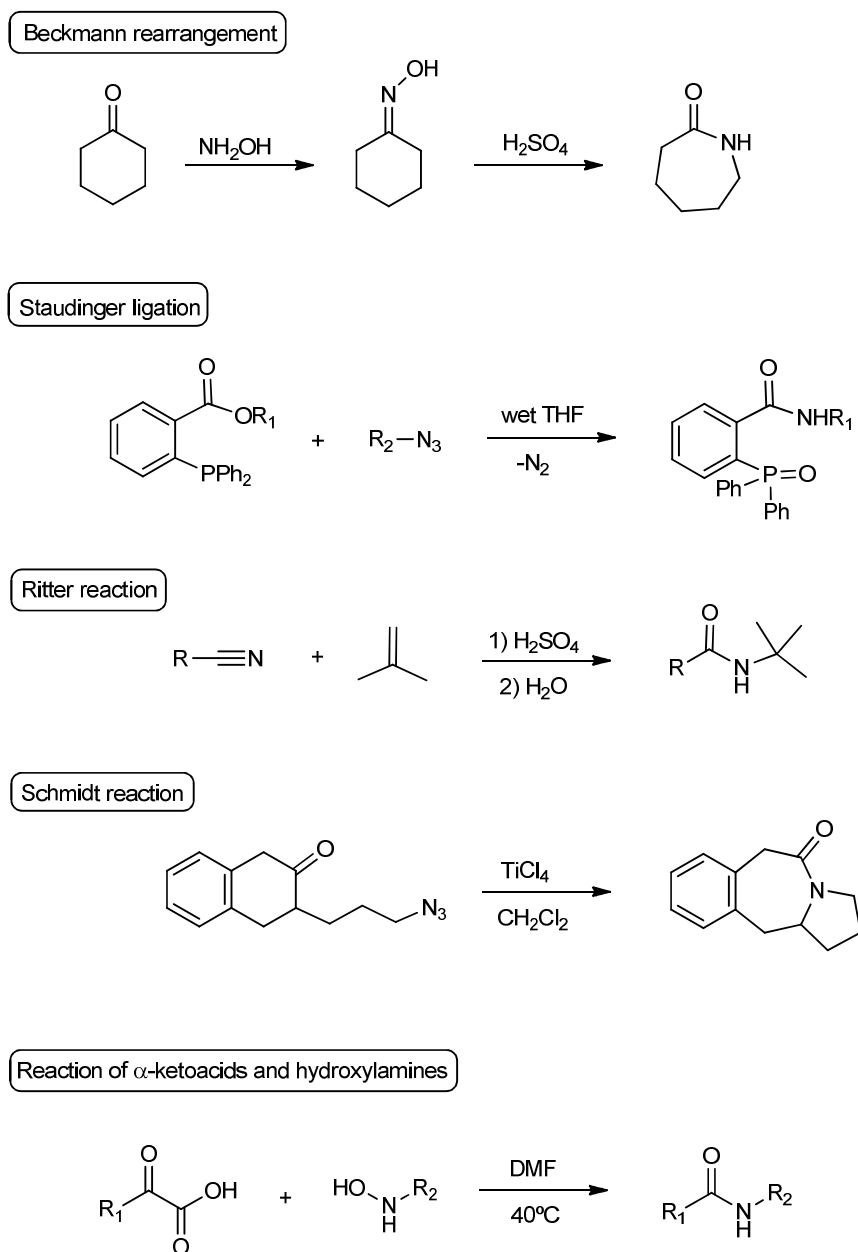

**Scheme 10** Several well known methods for amide syntheses

Although a number of methods are well known for the synthesis of amides, many of these produce stoichiometric amounts of byproducts which may be difficult to separate from the desired amide. This illustrates the importance of new and environmentally friendly ways for amide synthesis. However, the preparation of amides without generation of waste and the use of neutral conditions is a challenging goal.

### 2.1.2. Amide syntheses catalyzed by metal complexes

Lately, catalytic approaches that do not produce harmful byproducts have found much attention. A number of different systems have been developed and all of them are based on a variety of transition metal catalysts.

In 1986, Murahashi *et al.* reported a ruthenium-catalyzed condensation of nitriles with amines.<sup>48</sup> The reaction proceeds cleanly and with high efficiency under neutral conditions, although the reaction temperature is high and a sealed tube is needed (Scheme 11).

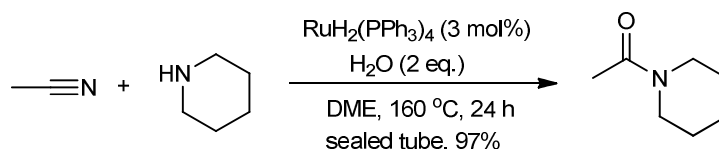

**Scheme 11** Ru-catalyzed condensation of nitriles with amines

Later, in 2008 the first catalytic oxygenation of primary amines to primary amides was reported.<sup>49</sup> The reaction is catalyzed by a readily prepared  $\text{Ru}(\text{OH})_x/\text{Al}_2\text{O}_3$  catalyst in the presence of molecular oxygen in water. This oxygenation offers significant advantages from the standpoint of green chemistry. However, the reaction had to be carried out inside an autoclave at 130-160 °C with 5 atmospheres of molecular oxygen (Scheme 12), which diminishes its general usefulness.

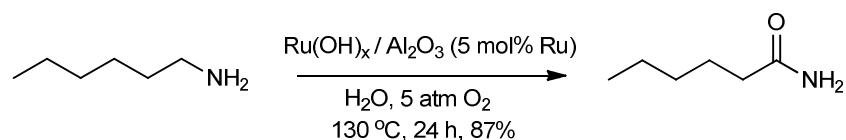

**Scheme 12** Oxygenation of primary amines

Recently, Milstein *et al.* presented an efficient homogeneous protocol for amide synthesis from alcohols and amines with the liberation of H<sub>2</sub>.<sup>50</sup> This was the first example that allowed for the direct amidation of alcohols with amines in an intermolecular fashion. The reaction is catalyzed by the ruthenium complex **2** based on a dearomatized PNN-type pincer ligand [2-(di-*tert*-butylphosphinomethyl)-6-(diethylaminomethyl)pyridine], and no base or acid promoters are required (Scheme 13). A number of different amides were synthesized from simple substrates without generating any stoichiometric byproducts, and thus with high atom economy. The disadvantages of this method are the relatively limited substrate scope and the complexity of the catalyst which must be synthesized via multiple steps. In addition, the reactions must be carried out under strict exclusion of oxygen, i.e. in a glove box. Although the mechanism of the reaction is not clearly understood, it has been proposed that during the catalytic cycle the aromatization of the pincer ligand occurs.

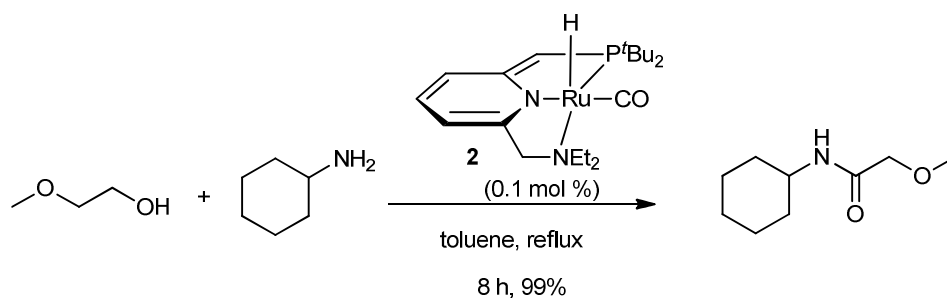

**Scheme 13** Synthesis of amides catalyzed by a PNN pincer complex

Since Milstein's initial report several *in situ* ruthenium catalysts for intermolecular amidation reactions have been developed. Williams *et al.* reported the formation of secondary amides using [Ru(*p*-cymene)Cl<sub>2</sub>]<sub>2</sub>, 1,4-bis(diphenylphosphino)butane (dppb), and Cs<sub>2</sub>CO<sub>3</sub> as the catalytic system in refluxing *tert*-butanol.<sup>51</sup> However, a hydrogen acceptor such as 3-

methyl-2-butanone (2.5 equiv. to the alcohol substrate) was required to promote the reaction (Scheme 14).

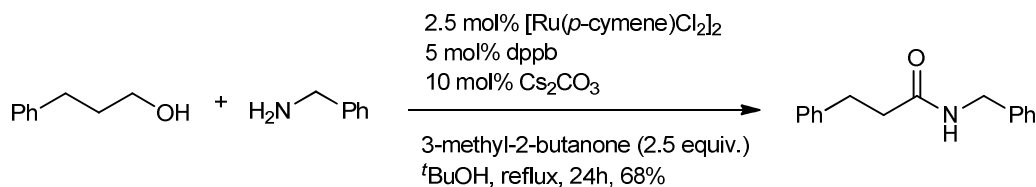

**Scheme 14** Synthesis of amides by Williams and co-workers

As a matter of fact, the ruthenium catalyzed amidation project was started by coincidence in the Madsen's group by the postdoctoral research fellow Henning Vogt. His actual goal was to develop a new ruthenium based catalyst for the alkylation of amines with alcohols. Surprisingly, when 2-phenylethanol and benzylamine were treated with an *in situ* formed Ru-phosphine-NHC complex the major product was the corresponding amide instead of the targeted amine (Scheme 15). After this first discovery Lars Ulrik Nordstrøm performed optimization studies and investigated the substrate scope for the reaction.<sup>52</sup>

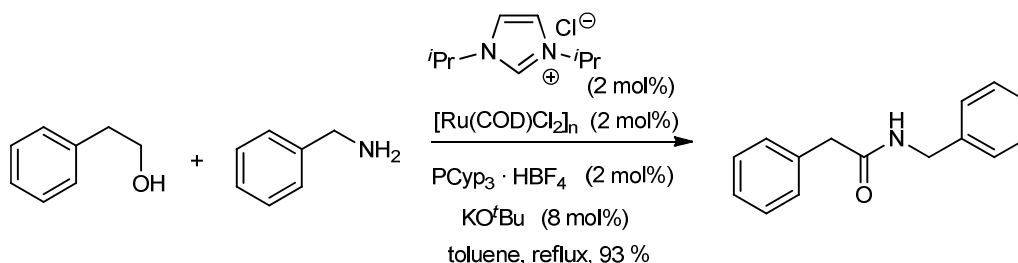

**Scheme 15** Synthesis of amides catalyzed by an *in situ* formed Ru-complex

Inspired by the results of Madsen *et al.* some different ruthenium catalyzed procedures have been developed since. One of the first contributions was from Hong *et al.* who reported a phosphine-free *in situ* generated ruthenium catalytic system, which consists of  $[\text{Ru}(p\text{-cymene})\text{Cl}_2]_2$  or  $[\text{Ru}(\text{benzene})\text{Cl}_2]_2$ , an NHC precursor, pyridine or acetonitrile and NaH.<sup>53</sup> The phosphine-free catalyst system showed similar activity as compared to the previous phosphine-based catalytic systems (Scheme 16).

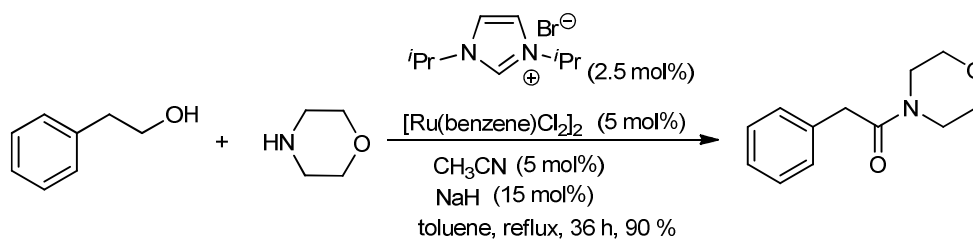

**Scheme 16** Phosphine-free catalyst system for amide synthesis

In addition, the Hong group has developed an *in situ* generated Ru catalyst (from  $RuH_2(PPh_3)_4$ , an NHC precursor, NaH and  $CH_3CN$ ) for the synthesis of amides from either alcohols or aldehydes with amines (Scheme 17).<sup>54</sup> It should be noted that this was the first example of a transition-metal-based catalytic system that efficiently transforms either alcohols or aldehydes into amides under the same reaction conditions. For the reaction mechanism a  $Ru(0)/Ru(II)$  cycle has been proposed based on the observation of hydrogen formation during the reaction.

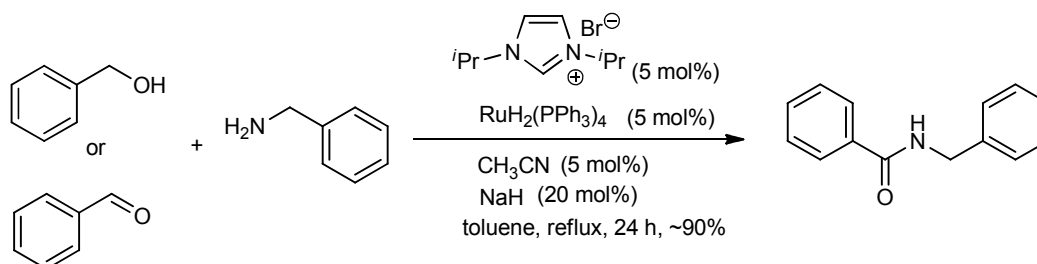

**Scheme 17** In situ Ru catalyst system by Hong for amidation

Most recently, well-defined 1,2,3-triazolylidene ruthenium complexes have also been identified as effective homogeneous catalysts for (1) base-free oxidation of benzylic alcohols to benzaldehydes, (2) homocoupling of amines and (3) the oxidative coupling of amines and alcohols to form amides (Scheme 18).<sup>55</sup> Nevertheless, only sterically unhindered alcohols and amines were tested for the amide synthesis.

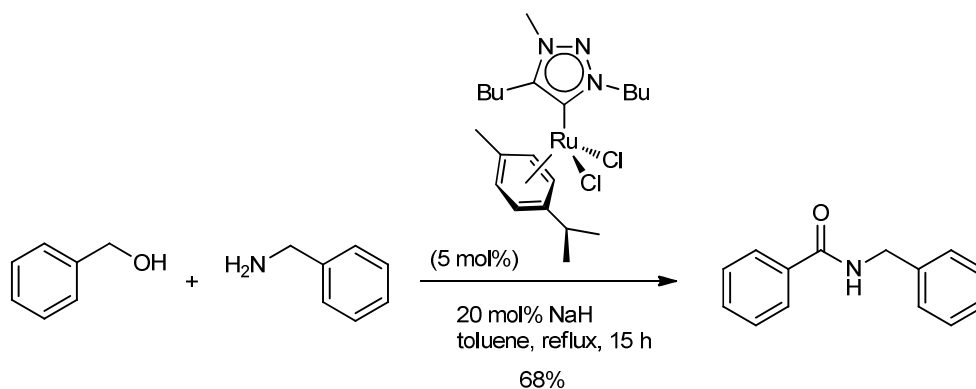

**Scheme 18** Formation of amides catalyzed by an isolated 1,2,3-triazolylidene ruthenium complex

The chemical rationale behind the recent examples of amide syntheses from alcohols and amines can be rationalized by considering the general mechanism illustrated in Scheme 19. An alcohol is initially oxidized to the corresponding aldehyde that reacts with the amine to produce a hemiaminal intermediate. Two possible pathways diverge after this: (1) the hemiaminal either would form an imine, which could be subsequently hydrogenated to an amine, (2) or would be further dehydrogenated to the corresponding amide. It is currently unexplored what properties of the catalytic systems affect the outcome of the intermediate toward the alkylation or the amidation.

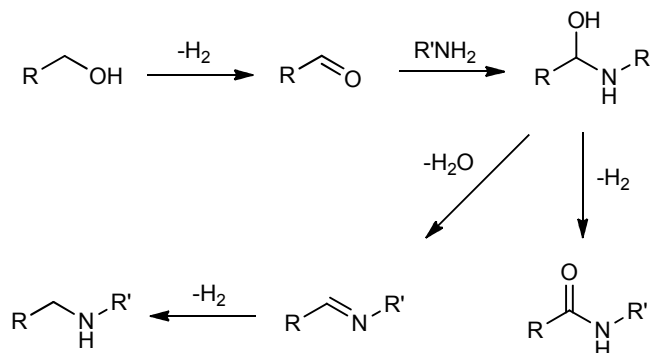

**Scheme 19** Proposed pathway for direct amide and amine synthesis from alcohols and amines

Interestingly, Eisenstein *et al.* have reported a ruthenium(II) diamine complex **3** which can catalyze the intramolecular cyclization of amino alcohols  $\text{H}_2\text{N}(\text{CH}_2)_n\text{OH}$  via two pathways:

one yields the cyclic secondary amide, while the other gives the corresponding cyclic amine (Scheme 20).<sup>56</sup>

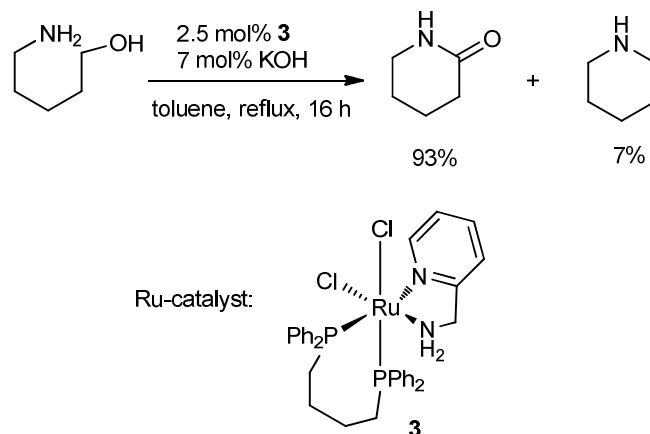

**Scheme 20** Ruthenium catalyzed intramolecular cyclization

In addition, computational studies have been performed to elucidate the mechanism of this transformation and to determine the factors that affect the switch between amide and amine formation. The computational investigations suggested that in both the amide and the amine formations the initial step is the oxidation of the amino-alcohol to the amino aldehyde, followed by the formation of the hemiaminal **4** which is a zwitterion protonated at the nitrogen. At this point a proton transfer occurs either between the nitrogen and the hydride to form complex **5** (Scheme 21, pathway a) or between the nitrogen and the oxygen in **6** (Scheme 21, pathway b). For amide formation the proton migrates to the hydride, while for the formation of the amine the proton is transferred to the oxygen. Therefore, the neutral hemiaminal **7** can be released from the metal, which undergoes dehydration followed by hydrogenation to yield the secondary amine. It has been calculated that the energy required for the H<sup>+</sup> transfer to the oxygen (Scheme 21, pathway b) is higher than that required for the H<sup>+</sup> migration to the hydride (Scheme 21, pathway a). This means that in the absence of an outer-sphere assistance for the proton transfer the energy of the transition state of **6** cannot be achieved and therefore the amide formation is favored.



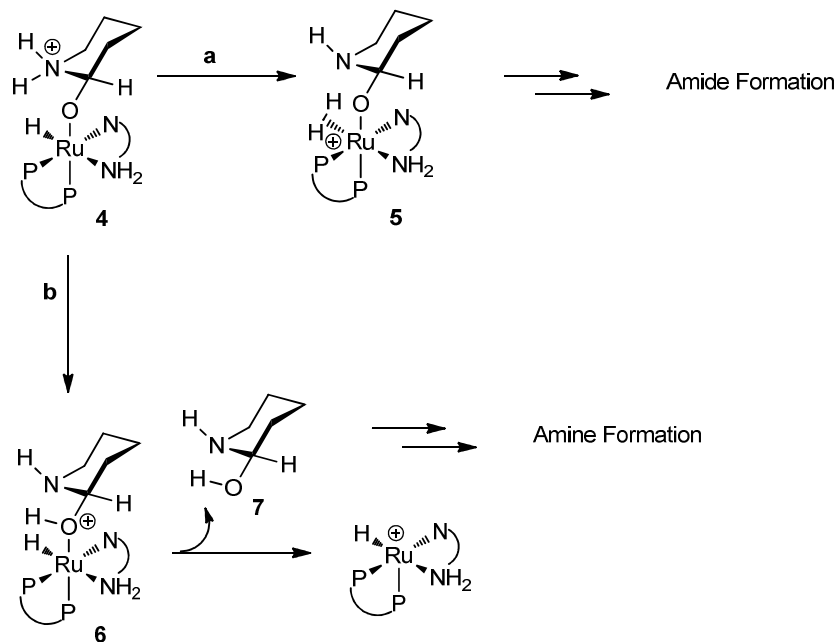

**Scheme 21** Mechanistic model for the switch between amide and amine formation

As a matter of fact, not only Ru-based catalyst but also Rh-based homogeneous and Ag-based heterogeneous catalysts have been developed for the direct amide synthesis (Scheme 22). Yamaguchi *et al.* have reported the first Rh-based catalytic system, using  $[\text{Cp}^*\text{RhCl}_2]_2$  and  $\text{K}_2\text{CO}_3$  in acetone, for lactamization of amino alcohols (Scheme 22, equation 1).<sup>57</sup> Acetone was used as a hydrogen acceptor as well as the solvent. According to the proposed mechanism a rhodium hydride species is generated by the  $\beta$ -hydride elimination from an alkoxide similar to the Ru catalysts. The Rh-based catalyst can also be exploited for intermolecular amide synthesis as was shown by Grützmacher *et al.* (Scheme 22, equation 2).<sup>58</sup> Like for the Yamaguchi system a hydrogen acceptor such as methyl methacrylate (MMA) is required to generate primary and secondary amides in excellent yields. Notably, the reaction occurs under much milder conditions than with the Ru-based catalyst systems, and can be achieved even at room temperature. Moreover, Shimizu *et al.* reported the first heterogeneously catalyzed amidation from alcohols with amines.<sup>59</sup> The catalyst is an alumina-supported silver cluster with  $\text{Cs}_2\text{CO}_3$  as the base (Scheme 22, equation 3).

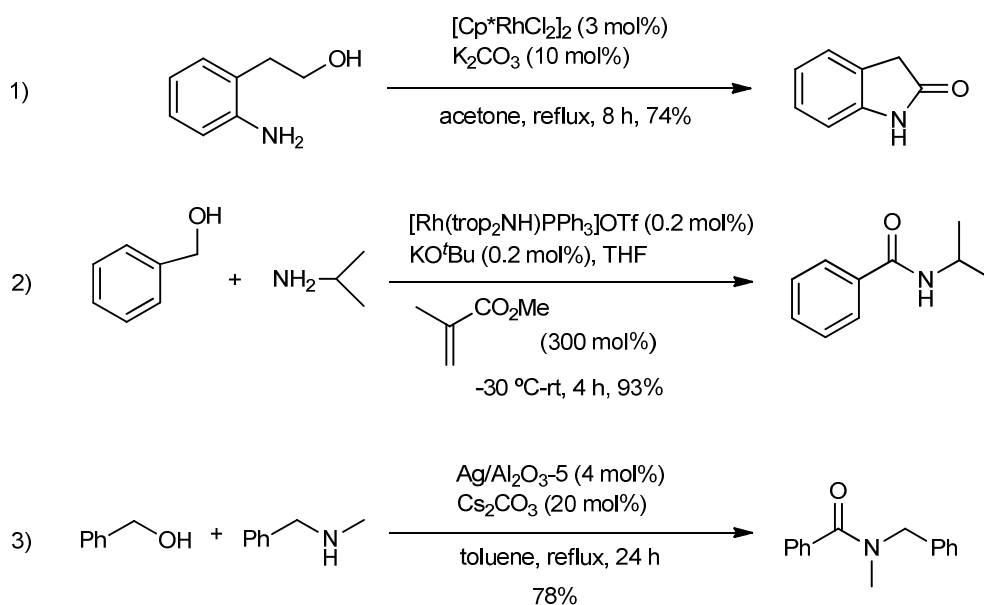

**Scheme 22** Amide syntheses catalyzed by Rh-based or Ag-based catalysts

Although several atom economical procedures are known for the formation of amides, there are still many challenges in this area in order for the emerging methodology to be widely applied for amide bond formation in organic synthesis.

## 2.2. Aim of the project

In recent years, a number of environmentally friendly transition metal catalyzed methods have been developed for coupling alcohols and amines. In Madsen's group major research has been done to investigate reactions including amide synthesis catalyzed by metal complexes. It has been shown that an *in situ* formed Ru-complex can catalyze the amidation reaction from alcohols and amines.<sup>52</sup> Since the catalyst was generated *in situ*, the mechanism of the reaction could not be fully elucidated. To better understand the exact role and nature of the catalyst, the development of a well-defined pre-catalyst is crucial.

On the other hand, a number of studies have reported that ruthenium is able to activate a C-H bond on a coordinated NHC-ligand.<sup>60</sup> In addition, in Milstein's report the PNN-pincer catalyst **2** was participating in the reaction by an aromatization / dearomatization shift.<sup>50</sup> Therefore, it raised the issue whether the NHC-ligand was involved in the catalytic cycle in a similar way.

According to these considerations, we decided to synthesize an effective ruthenium complex by installing a proper NHC ligand on the metal center. With a well-defined catalyst an actual mechanistic study can be performed and hopefully a more efficient catalyst be developed.

## 2.3. Results and discussion

### 2.3.1. Synthesis and test of a well-defined pre-catalyst

A pre-catalyst containing an NHC ligand with the same reactivity as the catalyst generated *in situ* is necessary to better understand the mechanism of the ruthenium-catalyzed amidation reaction. The ruthenium source used to generate the catalyst *in situ* was  $[\text{Ru}(\text{COD})\text{Cl}_2]_n$ . Thus, the simplest way to synthesize an efficient ruthenium complex seemed to introduce an NHC ligand on  $[\text{Ru}(\text{COD})\text{Cl}_2]_n$ . Different methods of carbene-addition or -transfer<sup>61,62</sup> were attempted, however, the ruthenium complex containing both an NHC ligand and a COD ligand was too sensitive to be isolated.

Numerous ruthenium(II)-*N*-heterocyclic carbene complexes with a *p*-cymene ligand are known to be stable, since these complexes form a saturated 18-electron system.<sup>63</sup> They have been used for hydrogenation and cyclopropanation of olefins.<sup>63</sup> In addition, it is known that the *p*-cymene ligand can be released at elevated temperature (85°C),<sup>64</sup> and since the amidation reaction takes place in refluxing toluene, the same catalytically active species can be generated.

In a number of preparations ruthenium(II)-*N*-heterocyclic carbene complexes are synthesized by transferring the free *N*-heterocyclic carbene ligand to  $[\text{Ru}(\textit{p}\text{-cymene})\text{Cl}_2]_2$ .<sup>65-67</sup> Alternatively, the complexes can also be prepared via silver carbene formation.<sup>66</sup> By applying this latter method, 1,3-diisopropylimidazolium chloride (*i*PrHCl) was treated with silver oxide ( $\text{Ag}_2\text{O}$ ) to form the corresponding silver carbene complex which was transmetallated with  $[\text{Ru}(\textit{p}\text{-cymene})\text{Cl}_2]_2$  in a one-pot reaction. The complex **8** was isolated by flash chromatography in 96% yield (Scheme 23).

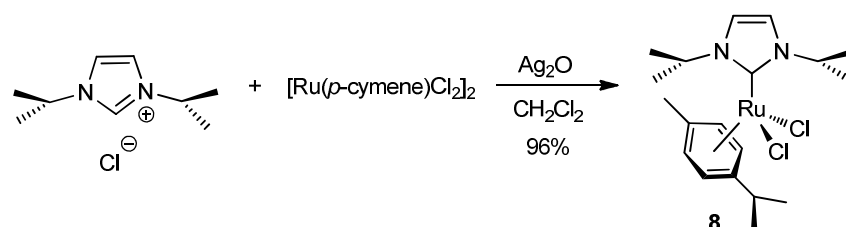

**Scheme 23** Synthesis of a well-defined pre-catalyst

At this point we could test the well-defined Ru complex **8** in the amidation reaction. According to the previous study in our group,<sup>52</sup> 2-phenylethanol and benzylamine were chosen as the standard substrates for optimizing the amidation reaction (Table 6). When the reaction was performed in the absence of base the imine deriving from the self-condensation of the amine was the only product observed (entry 1), while the reactions in the presence of 10 mol% potassium *tert*-butoxide (KO<sup>t</sup>Bu) afforded the amide exclusively (entry 2-5). Surprisingly, without phosphine ligand a yield below 70% of the amide was observed after 24 hours (entry 2). Although, in the previous study the PCyp<sub>3</sub>·HBF<sub>4</sub> salt<sup>69</sup> was chosen, this phosphine ligand was less effective with the complex **8** giving also less than 70% conversion (entry 3). On the contrary, the use of tricyclohexylphosphine (PCy<sub>3</sub>), as well as tricyclopentylphosphine (PCyp<sub>3</sub>), resulted in the amide in high yield (entries 4 and 5).

**Table 6** Amidation catalyzed by well-defined Ru NHC complex **8**

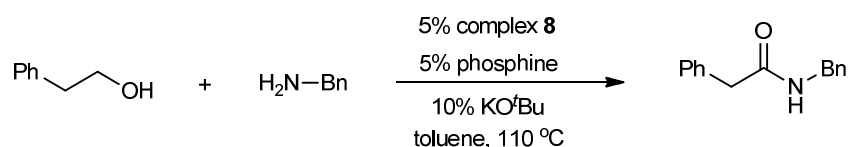

Entry	Phosphine	Base	GC yield (3 h)	GC yield (24 h)
1 <sup>a</sup>	PCyp <sub>3</sub> ·HBF <sub>4</sub>	-	-	-
2	-	KO <sup>t</sup> Bu	55%	70%
3	PCyp <sub>3</sub> ·HBF <sub>4</sub>	KO <sup>t</sup> Bu	19%	61%
4	PCy <sub>3</sub>	KO <sup>t</sup> Bu	65%	95%
5	PCyp <sub>3</sub>	KO <sup>t</sup> Bu	53%	100%

<sup>a</sup>Imine formation from the self-condensation of the amine was observed

### 2.3.2. Study of other pre-catalysts

Since the new pre-catalyst proved to be efficient in the amide formation other NHC ruthenium-cymene complexes were also synthesized to investigate the influence of the carbene ligand and the halide. In fact, we decided to replace the isopropyl wing tips in **8** with cyclohexyl groups and the chloride to iodide. Therefore, [RuCl<sub>2</sub>(*p*-cymene)ICy] (**9**) and [RuI<sub>2</sub>(*p*-cymene)ICy] (**10**) complexes were prepared via silver carbene transfer methodology

from 1,3-dicyclohexylimidazolium chloride (ICyHCl) and  $[\text{Ru}(p\text{-cymene})\text{I}_2]_2$  (Scheme 24). The corresponding ICyHCl is not commercially available, and it was therefore synthesized according to Mistryukov's procedure (Scheme 24, equation 1).<sup>70</sup> The reaction between ICyHCl and  $[\text{Ru}(p\text{-cymene})\text{I}_2]_2$  gave a mixture of the dichloride (**9**, yellow band on preparative TLC) and the diiodide (**10**, red band on preparative TLC) complexes which were easily separated by preparative TLC (Scheme 24, equation 2).

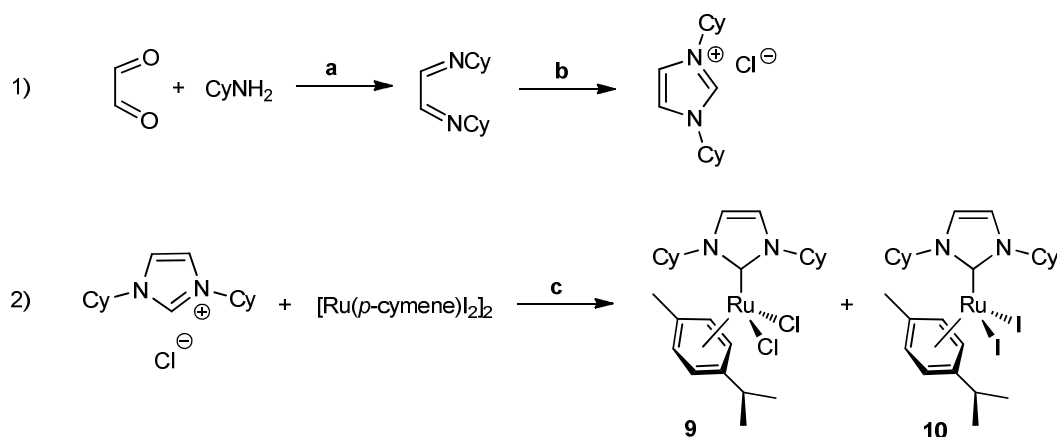

**a:**  $\text{CaCl}_2$ ,  $\text{CH}_2\text{Cl}_2$  (80%); **b:**  $\text{CH}_2(\text{NMe})_2$ ,  $\text{AcCl}$ ,  $\text{CH}_2\text{Cl}_2$ , (79%); **c:**  $\text{Ag}_2\text{O}$ ,  $\text{CH}_2\text{Cl}_2$  (43% **9** and 49% **10**)

**Scheme 24** Synthesis of 1,3-dicyclohexylimidazolium chloride and (NHC)Ru(*p*-cymene) complexes

Having the complexes **9** and **10** at hand the standard amidation reaction was tested with them using either  $\text{PCy}_3$  or  $\text{PCyp}_3$  as the phosphine ligand in the presence of  $\text{KO}^t\text{Bu}$  (Table 7). With added  $\text{PCy}_3$  and base complex **9** performed very well in the amidation resulting in 61% amide formation after 3 hours and 97% after 24 hours (entry 1). The use of  $\text{PCyp}_3$  afforded a slightly lower yield (entry 2). In contrast, the diiodide complex **10** was much less reactive and more byproducts were detected (entries 3 and 4). However, when the catalyst was generated *in situ* by the addition of  $[\text{Ru}(p\text{-cymene})\text{I}_2]_2$ , ICyHCl, phosphine and  $\text{KO}^t\text{Bu}$  a similar reactivity as of complex **9** was observed (entries 5 and 6). The *in situ* generated catalyst may be a mixture of **9** and **10**, but it shows that the influence of the halide is significant. The weaker coordinating iodide ligand makes complex **10** less stable than **9** and the reactivity difference could be explained by this difference in stability. Regardless of the phosphine ligand employed both complexes **8** (Table 6) and **9** (Table 7) performed almost equally well.

Due to some practical reasons we decided to select the catalyst system composed of complex **8**, PCy<sub>3</sub> and KO<sup>t</sup>Bu for further investigation.

**Table 7** Amidation reactions with (NHC)Ru(*p*-cymene) complexes

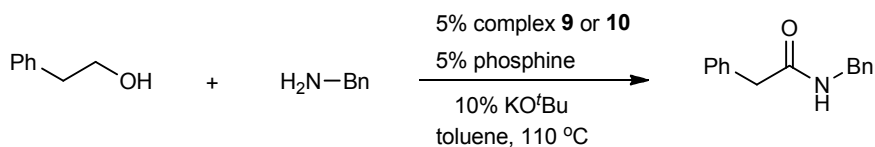

Entry	Complex	Phosphine	GC yield (3 h)	GC yield (24 h)
1	<b>9</b>	PCy <sub>3</sub>	61%	97%
2	<b>9</b>	PCyp <sub>3</sub>	56%	91%
3	<b>10</b>	PCy <sub>3</sub>	22%	50%
4	<b>10</b>	PCyp <sub>3</sub>	29%	44%
5	<b>10<sup>a</sup></b>	PCy <sub>3</sub>	56%	90%
6	<b>10<sup>a</sup></b>	PCyp <sub>3</sub>	63%	87%

<sup>a</sup> In situ generated catalyst from [Ru(*p*-cymene)I<sub>2</sub>]<sub>2</sub> and 1,3-dicyclohexylimidazolium chloride in the presence of 15 mol% KO<sup>t</sup>Bu.

At this point a report from 2001 attracted Dr. Johan Hygum Dam's attention. Grubbs *et al.* showed that the benzylidene ligand on Grubbs 2<sup>nd</sup> generation metathesis catalyst<sup>71</sup> can be removed by hydrogenation without affecting the *N*-heterocyclic carbene ligand.<sup>72</sup> According to this observation the liberation of dihydrogen in the amidation reaction may cleave the benzylidene ligand and afford an active species for the amide transformation. This fact prompted him to investigate the performance of different metathesis catalysts<sup>73</sup> in the amidation reaction (Table 8). Although no metathesis catalyst by its own brought any improvement, applying the Hoveyda-Grubbs 1<sup>st</sup> generation catalyst<sup>74</sup> without the NHC ligand resulted in the desired product in moderate yield (entry 1a), while the addition of I<sup>*i*</sup>PrHCl or ICyHCl considerably improved the yield and after 24 hours almost quantitative amide formation was obtained (entries 1b and 1c). Surprisingly, the newer Grubbs 3<sup>rd</sup> generation metathesis catalyst<sup>75</sup> containing a saturated NHC ligand had comparable reactivity to the complexes **8** and **9** and afforded the desired amides in 92% yield after 24 hours (entry 2). Even though the active species of the catalyst is still generated *in situ*, the catalyst system of

Hoveyda-Grubbs 1<sup>st</sup> generation, *i*PrHCl carbene ligand and KO<sup>t</sup>Bu base were chosen for further investigation.

**Table 8** Amidation reactions with metathesis catalysts

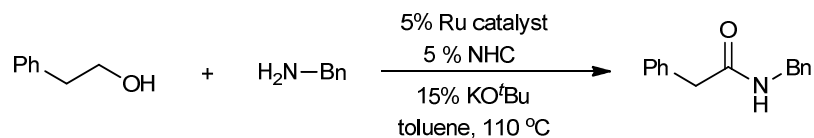

Entry	Metathesis catalyst	GC yield (3 h / 24h) [%]	Entry	Metathesis catalyst	GC yield (3 h / 24h) [%]
1a	 Hoveyda-Grubbs 1 <sup>st</sup>	41 / 60	2	 Grubbs 3 <sup>rd</sup>	63 / 92
1b		84 / 100 <sup>a</sup>			
1c		72 / 97 <sup>b</sup>			

<sup>a</sup>With 5 mol% ICyHCl and 15 mol% KO<sup>t</sup>Bu;

<sup>b</sup>With 5 mol% *i*PrHCl and 15 mol% KO<sup>t</sup>Bu

### 2.3.4. Substrate scope

Having two effective catalyst systems at hand the substrate scope and limitation of the reaction could now be studied. The first catalyst system (catalyst **A**) consists of complex **8**, PCy<sub>3</sub> and KO<sup>t</sup>Bu, while the second one (catalyst **B**) is composed of Hoveyda-Grubbs 1<sup>st</sup> generation catalyst, 1,3-diisopropylimidazolium chloride (*i*PrHCl) and KO<sup>t</sup>Bu (Figure 3).

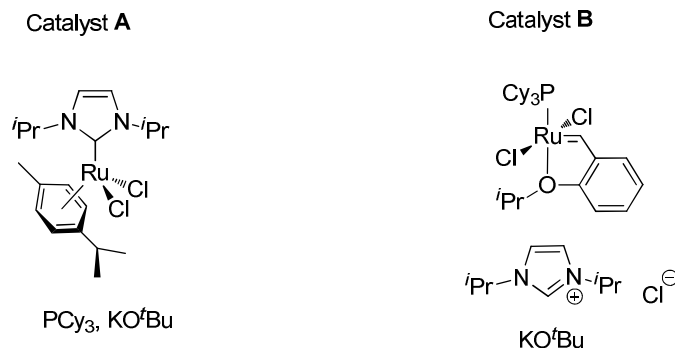
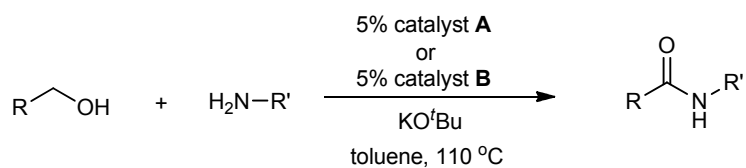

**Figure 3** Catalyst systems for the amidation



Equimolar amounts of different primary alcohols and amines were reacted with catalyst **A** and **B** to afford the desired amides (Table 9). In all reactions 5 mol% of the corresponding Ru-complex, and either 5 mol% of PCy<sub>3</sub> (with catalyst **A**) or 5 mol% of *t*-PrHCl (with catalyst **B**) were employed besides 10 mol% of base. With both of the catalysts the amidation reactions of sterically unhindered alcohols and amines gave excellent yield (entries 1-3), while benzyl alcohol with benzyl amine furnished the corresponding benzamide in moderate yield (entry 4). The *p*-chlorophenethyl alcohol performed well in the amidation (entry 5). However, the aryl bromide analogue and the *p*-nitro derivative gave very low yield (entries 6 and 7). On the other hand, the reaction between hex-5-en-1-ol and benzylamine resulted in the corresponding hexanamide in a very good yield, where the olefin was reduced with the liberated dihydrogen (entry 8). The reaction of *N*-benzylethanolamine with benzylamine afforded the corresponding amide in high yield, which shows that the amidation is selective for the primary amine in the presence of a secondary amine (entry 9). A sterically more hindered and optically pure amine also gave the desired amide in excellent yield with no sign of racemization (entry 10). Noteworthy, the preparation of the amide with a chiral center in the  $\alpha$ -position succeeded without racemization (entry 11). The reaction catalyzed by the two catalyst systems could also be performed in an intramolecular fashion to generate both five- and seven-membered lactams (entries 12 and 13). As shown in entries 14 and 15 with the use of aniline as well as a secondary amine the reaction did not take place under the standard conditions, however, increasing the temperature to 163 °C in mesitylene resulted in the formation of the desired products in moderate to good yield.

**Table 9** Substrate scope of the amidation reaction

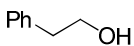
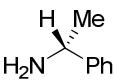
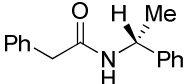
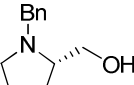
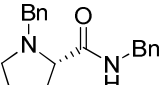
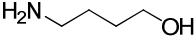
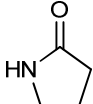
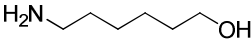
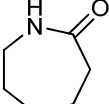
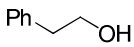
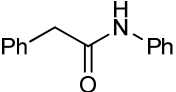
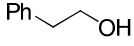
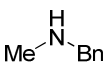
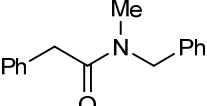

Entry	Alcohol	Amine	Amide	Isolated yield with catalyst <b>A</b>	Isolated yield with catalyst <b>B</b>
1		H <sub>2</sub> N-Bn		95%	88%
2		H <sub>2</sub> N-(CH <sub>2</sub> ) <sub>4</sub>		90%	95%
3		H <sub>2</sub> N-Bn		94%	86%
4		H <sub>2</sub> N-Bn		78%	67%
5		H <sub>2</sub> N-Bn		71%	73%
6		H <sub>2</sub> N-Bn		4%	-
7		H <sub>2</sub> N-Bn		3%	-
8		H <sub>2</sub> N-Bn		82%	78%
9		H <sub>2</sub> N-Bn		93%	87%

10				85%	78%
11		H <sub>2</sub> N-Bn		53%	44%
12				68%	60%
13				53%	48%
14 <sup>a</sup>		H <sub>2</sub> N-Ph		35%	33%
15 <sup>a</sup>				65%	70%

<sup>a</sup>In mesitylene at 163 °C

Obviously, the two catalysts (**A** and **B**) did not show any major differences in yield and reactivity. This indicates that the catalytically active species must be the same in both cases.

Additional substrates were tested by employing catalyst **A** and catalyst **B** (Table 10), however, most of them resulted in no conversion or only trace amounts of the amide products were observed by GC. These substrates have at least two Lewis basic heteroatoms in close proximity. Therefore, they could bind significantly stronger to the metal center and might inactivate the catalyst.

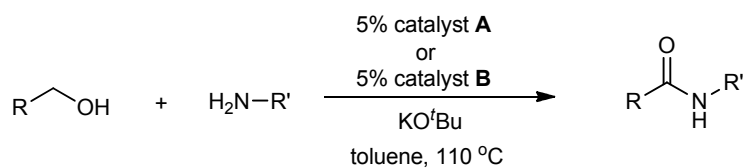
**Table 10** Substrates that did not lead to the corresponding amide formation

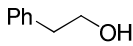
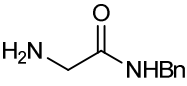
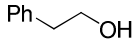
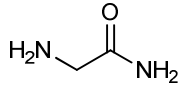
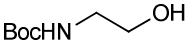
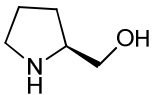
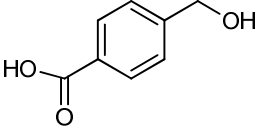
Entry	Alcohol	Amine	Amide
1			No conversion
2			No conversion
3		$\text{H}_2\text{N-Bn}$	Low conversion Trace product
4		$\text{H}_2\text{N-Bn}$	Low conversion Trace product
5		$\text{H}_2\text{N-Bn}$	No conversion

### 2.3.5. Tandem reaction with olefin cross metathesis and amidation

As shown by Johan Hygum Dam a few catalytic systems, in which the ruthenium complexes are active towards olefin metathesis,<sup>76</sup> are also efficient in the synthesis of amides. Therefore, we thought to combine the olefin cross metathesis (CM) reaction with the amidation in a tandem one-pot transformation (Scheme 25).

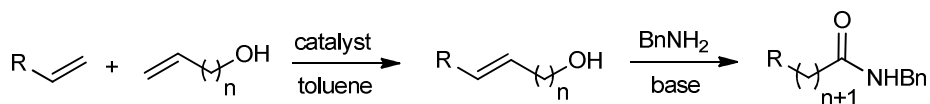

**Scheme 25** Tandem one-pot reaction with olefin cross metathesis and amidation reactions

Robert H. Grubbs *et al.* have established general rules for predicting the selectivity in CM reactions.<sup>77</sup> According to these rules olefins have been categorized into 4 groups based on their relative abilities to undergo homodimerization via cross metathesis and the susceptibility of their homodimers toward secondary metathesis reactions (Table 11).

**Table 11** Olefin categories for selective cross metathesis

Olefin type	Olefins (examples)
Type I (fast homodimerization)	terminal olefins, allylic alcohols, allylic esters, allyl silanes, allyl halides
Type II (slow homodimerization)	styrenes, acrylates, secondary allylic alcohols, vinyl ketones
Type III (no homodimerization)	1,1-disubstituted olefins, non-bulky trisubstituted olefins, vinyl phosphonates, acrylonitrile
Type IV (spectators to CM)	vinyl nitro olefins, trisubstituted allyl alcohols, disubstituted $\alpha,\beta$ -unsaturated carbonyls

Type I olefins can undergo a rapid homodimerization. The homodimers can be consumed in a cross metathesis reaction as well as their terminal olefin counterparts. Type II olefins homodimerize more slowly and their homodimers can hardly participate in subsequent metathesis reactions. Type III olefins are essentially unable to get homodimerized by the catalyst. However, they are still able to undergo CM with Type I and Type II olefins. Type IV olefins are not able to participate in CM with Grubbs 1<sup>st</sup> generation catalyst, but do not inhibit the activity of the catalyst toward other olefins.

Considering these rules, 5-hexen-1-ol (Type I) and 3,3-dimethyl-1-butene (Type III) were selected and tested in CM-amidation tandem reaction by the use of Hoveyda-Grubbs 1<sup>st</sup> generation catalyst. Surprisingly, the homodimer of 5-hexen-1-ol was obtained (Scheme 26).

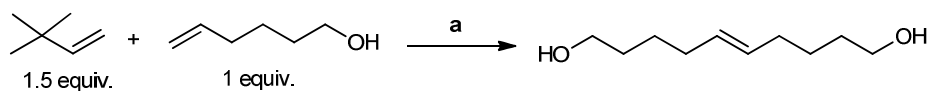

**a:** Hoveyda-Grubbs 1<sup>st</sup>, toluene (47 %)

**Scheme 26** Homodimerization of 5-hexen-1-ol

This result may be explained by the high steric hinderance of 3,3-dimethyl-1-butene resulting from the tert-butyl group in  $\alpha$ -position to the double-bond. The terminal olefin undergoes homodimerization very easily, thus the Type III olefin may have no chance to react. Therefore, the less sterically hindered vinylcyclohexane was chosen instead and reacted with 5-hexen-1-ol under the same reaction conditions. This time the olefin cross metathesis reaction succeeded smoothly and afforded the cross product in 85% yield (Scheme 27).

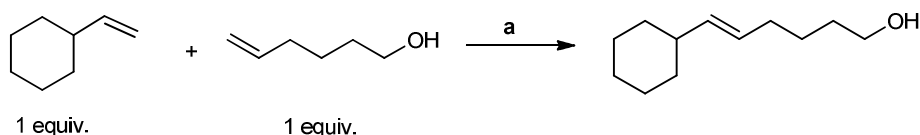

**a:** Hoveyda-Grubbs 1<sup>st</sup>, toluene (85 %)

**Scheme 27** Olefin cross metathesis catalyzed by Hoveyda-Grubbs 1<sup>st</sup> generation catalyst

Accordingly, the tandem CM-amidation reaction was now attempted. First, the two olefins were reacted for 24 hours by means of Hoveyda-Grubbs 1<sup>st</sup> generation catalyst, and then benzylamine and KO<sup>t</sup>Bu were added to the mixture. However, after 24 hours only trace amount of the desired amide was observed. This indicates that Hoveyda-Grubbs 1<sup>st</sup> generation catalyst is not suitable for the amide formation and the presence of the NHC is essential. Therefore, we decided to repeat the reaction using the catalyst **B** (Hoveyda-Grubbs 1<sup>st</sup>, *i*PrHCl and KO<sup>t</sup>Bu). In this case, the amide formation from the cross product was not observed, only from the starting alcohol. The inhibition of the CM reaction may be explained by considering that the ruthenium in catalyst **B** bears an unsaturated carbene ligand, while the well-known 2<sup>nd</sup> and 3<sup>rd</sup> generation metathesis catalysts<sup>71,75,78</sup> consist of saturated carbenes. Since Grubbs 3<sup>rd</sup> generation catalyst has already proven to be suitable for the amidation reaction, the same experiment catalyzed by Grubbs 3<sup>rd</sup> generation catalyst was also investigated. Interestingly, the olefin cross metathesis reaction, followed by adding

benzylamine and  $KO^tBu$  now resulted in the amidated cross product in moderate yield (Scheme 28).

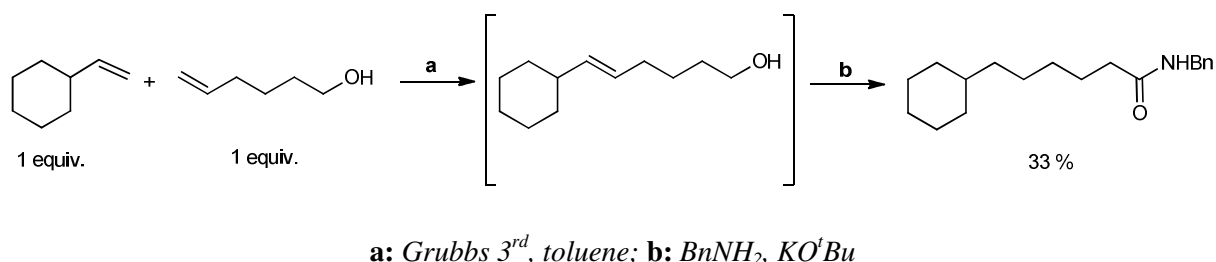

**Scheme 28** Tandem one-pot reaction with olefin cross metathesis and amidation

This result indicates that Grubbs 3<sup>rd</sup> generation catalyst is efficient for an olefin cross metathesis reaction followed by the amidation in a one-pot sequence. It should be noted that probably a more efficient method can be developed by substrate selection and optimization of the reaction conditions.

### 2.3.6. Mechanistic studies

The amidation reaction can be envisioned via different pathways (Scheme 29). We hypothesize that the alcohol is first oxidized to the corresponding aldehyde. At this point the aldehyde could be attacked by a second molecule of alcohol to form the corresponding ester, which can react with the amine to afford the desired amide (Scheme 29, pathway a). Alternatively, the amine can react with the aldehyde to give the corresponding hemiaminal. The hemiaminal formation can take place either in solution (Scheme 29, pathway b) or in the coordination sphere of the metal (Scheme 29, pathway c).

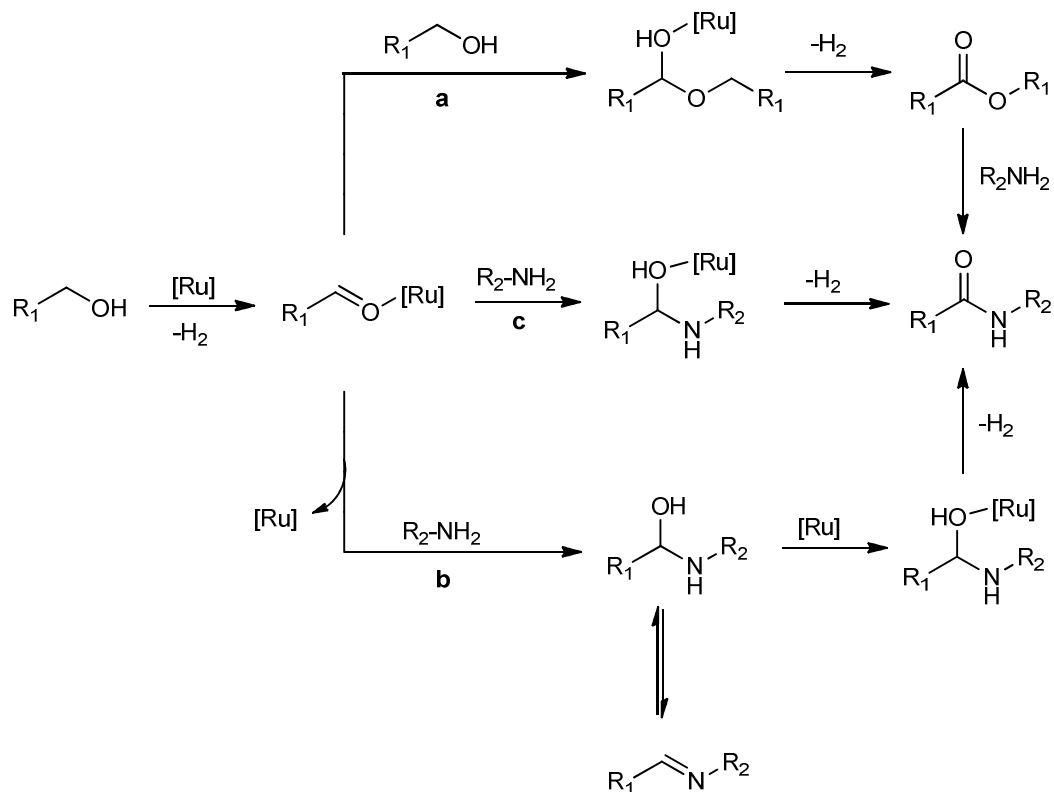

**Scheme 29** Possible pathways of the amidation reaction

If the aldehyde is released from the metal, the imine deriving from the dehydration of the hemiaminal should be obtained as an intermediate. However, neither imine nor ester intermediates have been observed by GC. This can indicate that the reaction may go through the pathway c, although this suggestion remains to be verified. Previously, the ester 2-phenylethyl 2-phenylacetate was reacted with benzylamine in the presence of the preformed catalyst in refluxing toluene.<sup>52</sup> The ester was stable under these conditions and no amide formation was observed. This proves that the amide formation does not proceed via the ester intermediate.

In addition, when benzaldehyde and benzylamine were added to catalyst **A** in the presence of KO<sup>t</sup>Bu the corresponding imine was formed and did not react any further. This may demonstrate that the aldehyde stays coordinated to the ruthenium catalyst and is not released into the solution. Interestingly, in Hong's report for the same reaction between benzaldehyde and benzylamine with the phosphine-free Ru catalyst system generated *in situ*, the corresponding amide (48%) was obtained with the concurrent formation of the imine (14%).<sup>53</sup>



In order to further investigate the mechanism of the amidation, a series of experiments were performed (Table 12). First, *p*-methylbenzyl alcohol (1 equiv.) and benzaldehyde (1 equiv.) were reacted with *n*-hexylamine (2 equiv.) in the presence of catalyst **A**. After 24 hours the aldehyde was completely converted to the imine **11**, while the alcohol resulted in the unexpected imine **12** formation with about 50% conversion. Only trace amounts of the amide **13** deriving from the alcohol were observed (entry 1).

To get a better picture cross over experiments were carried out with catalyst **A** under the standard reaction conditions. When benzaldehyde (1 equiv.) was added over 3 hours to a mixture of *p*-methylbenzyl alcohol (1 equiv.) and *n*-hexylamine (2 equiv.), the aldehyde reacted immediately with the amine to afford the corresponding imine **11**, while the alcohol provided a 2:1 mixture of the amide **13** and the imine **12** with 50% conversion after 4 hours and with almost complete conversion after 24 hours. However, a small amount of *N*-benzyl benzamide (**14**) from the aldehyde was also obtained as a byproduct. The ratio between the two amides (**13** and **14**) was 10:1 after 4 hours and it did not change after 24 hours (entry 2). Furthermore, when the amine (2 equiv.) was added over 3 hours to the reaction mixture of the alcohol (1 equiv.), aldehyde (1 equiv.) and the catalyst, the aldehyde was completely converted to the imine **11**, while the alcohol gave the corresponding imine **12** with around 50% conversion. After 24 hours unreacted amine and alcohol still remained, and no amide formation was obtained (entry 3).

**Table 12** Competition and cross over experiments

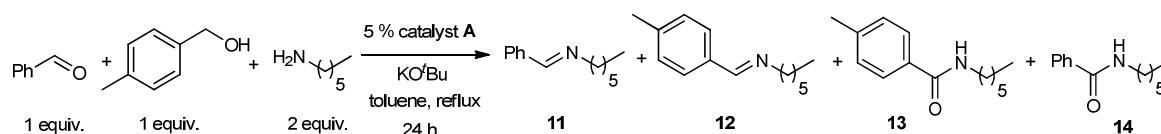

Entry	GC Yield of <b>11</b> [%]	GC Yield of <b>12</b> [%]	GC Yield of <b>13</b> [%]	GC Yield of <b>14</b> [%]
1	100	~50	Trace	-
2 <sup>a</sup>	~93	~33	~66	~7
3 <sup>b</sup>	100	~50	-	-

<sup>a</sup>Adding the aldehyde over 3 hours

<sup>b</sup>Adding the amine over 3 hours

These results confirm that the presence of the imine inhibits the amide reaction. The imine may coordinate strongly to the metal and thereby prevent the substrates from reacting efficiently. The imine formation from the alcohol indicates that a significant amount of alcohol was oxidized to the aldehyde stage but only a small amount was converted to the amide. Presumably, the imine may displace the aldehyde from the metal center, but not the alcohol. When the substrate at the aldehyde stage is released from the catalyst it can react with the amine to result in the imine formation. According to these results we can conclude that the entire reaction must take place on the metal (scheme 29, pathway c).

It should be noted that at the same time well-defined *N*-heterocyclic carbene based Ru complexes, similar to catalyst **A**, were published by the Hong group for the direct amide synthesis from alcohols and amines.<sup>79</sup> Interestingly, a Ru(0)/Ru(II) catalytic cycle was proposed and a [Ru]H<sub>2</sub> species was suggested as the active catalytic intermediate generated from [Ru]Cl<sub>2</sub> with the help of a base. Further investigation indicated that the presence of the primary alcohol and the base is essential to generate the catalytically active [Ru]H<sub>2</sub> species, but once it is formed, the amidation can take place from either alcohol or aldehyde. Therefore, it is not certain whether the generated aldehyde is free or coordinated to the metal.

In contrast to Hong's proposal of a Ru(0)/Ru(II) cycle, based on our studies we believe that the generated aldehyde and the hemiaminal stay coordinated to the ruthenium. Moreover, all the ruthenium species remain in the same oxidation state as the starting complex. Accordingly, a tentative mechanism of the amidation reaction is proposed in Scheme 30. The transformation is initiated by loss of the *p*-cymene ligand upon heating. Reaction with an alkoxide followed by  $\beta$ -hydride elimination affords aldehyde complex **15**. This part is similar to what has been established for ruthenium transfer hydrogenation catalysts.<sup>80</sup> However, it should be noted that (PPh<sub>3</sub>)<sub>3</sub>RuCl<sub>2</sub> is known to react with alcohols under basic conditions to form the dihydride complex (PPh<sub>3</sub>)<sub>3</sub>RuH<sub>2</sub>.<sup>81</sup> Whether complex **8** also reacts twice with the alkoxide is not known at this point. In fact, the last ligand on ruthenium in **15** could be chloride, hydride or an amine and is therefore denoted X in Scheme 30. A more thorough mechanistic study will have to be carried out to differentiate between these three scenarios. With formation of the aldehyde complex **15** a catalytic cycle can be proposed where the amine adds to the aldehyde to form the hemiaminal which stays coordinated to the metal. Release of hydrogen can take place by hydrogen transfer to hydride as previously

established.<sup>82</sup> This gives rise to complex **16** which upon  $\beta$ -hydride elimination releases the amide. Coordination of the alcohol and a second hydrogen transfer to hydride affords the alkoxide complex **17** which is ready to reenter the catalytic cycle.

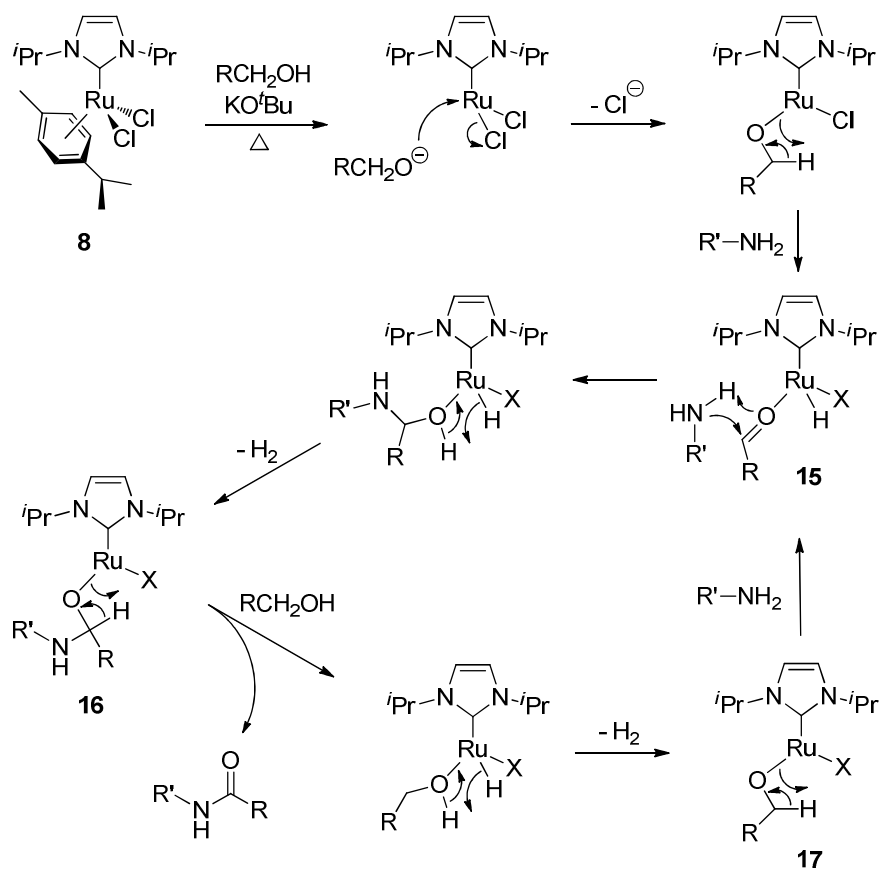

**Scheme 30** Proposed mechanism of the amide formation

## 2.4. Conclusion

An efficient method has been developed for the direct synthesis of amides from primary alcohols and amines where hydrogen gas is the only byproduct. The reaction can be catalyzed by a number of ruthenium *N*-heterocyclic carbene complexes.

Two well-defined catalysts – [RuCl<sub>2</sub>(*p*-cymene)I<sup>*i*</sup>Pr] and [RuCl<sub>2</sub>(*p*-cymene)ICy] (**8** and **9**) – were synthesized and showed similar reactivity to the previous catalyst system generated *in situ*, although the addition of a phosphine ligand and a base is still required.

Furthermore, an array of various metathesis catalysts appeared to catalyze the amidation reaction efficiently under certain reaction conditions. Two catalytic systems (catalyst **A** and **B**) have been selected for further investigation of the amidation with a wide variety of alcohols and amines. The substrate scope has showed that the reactions with unhindered alcohols and amines afforded the corresponding amides in good to excellent yields. Notably, the asymmetric centers were tolerated even in the  $\alpha$ -position. However, the amidation could not take place in the presence of several functional groups (e.g. *N*-Boc, nitro, aryl bromide).

In addition, Grubbs 3<sup>rd</sup> generation catalyst has been shown to catalyze a tandem one-pot reaction combining the olefin cross metathesis reaction and the amidation reaction.

Finally, a reaction mechanism has also been proposed. We believe that ruthenium(II) *N*-heterocyclic carbene species are the catalytically active components and the intermediate aldehyde and hemiaminal stay coordinated to ruthenium in the catalytic cycle.

### 3. Synthesis of a trisaccharide probe as a putative virus receptor and a D-glucuronic acid thioglycoside building block

#### 3.1. Literature background

##### 3.1.1. Dengue virus – epidemiology, infection

Dengue fever is caused by the Dengue virus (DENV), a mosquito-borne flavivirus.<sup>83</sup> Recently, dengue fever has re-emerged worldwide as a result of population growth and movement, urbanisation and a lapse of vector control. It has been documented that DENV and its numerous forms have spread to the majority of the tropical and subtropical regions of the world.<sup>84</sup> The virus is now endemic in more than 100 countries spanning Africa, the Americas, the Eastern Mediterranean, South East Asia, the Western Pacific, Indonesia and India (Figure 4). The World Health Organisation (WHO) estimated that 2.5 billion people, or two-fifths of the world's population, is at risk from the dengue virus, which can cause serious illness and in some cases death.<sup>85</sup>

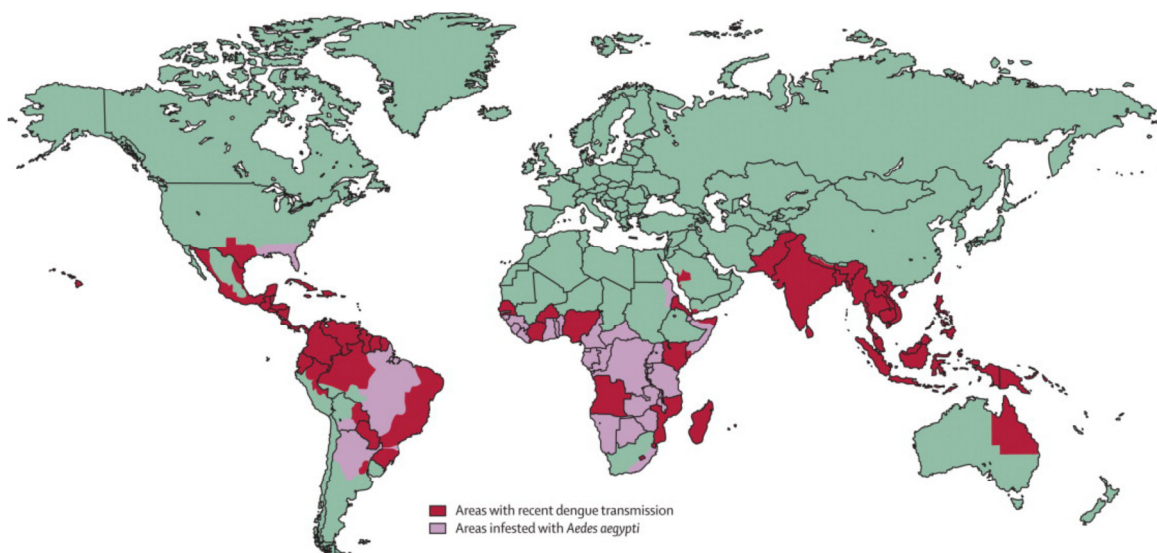

**Figure 4** The geographical distribution of the *Aedes aegypti* mosquito (pink) and recent epidemic activity of DENV (red) throughout the world<sup>86</sup>

DENV is transmitted by *Aedes* mosquitoes, particularly *A. aegypti* and *A. albopictus*.<sup>87</sup> Following inoculation into the skin, DENV replicates in local dendritic cells (DC).<sup>88</sup> Systemic

infection of macrophages and lymphocytes ensues, followed by entry of the virus into the bloodstream and subsequent infection of further cellular targets.<sup>89</sup> Not all cases of dengue fever cause significant illness due to host determinants, but those that do are characterized by an acute febrile illness similar to influenza.<sup>90</sup> The WHO has defined classical dengue fever as a symptomatic infection that presents after an incubation period of 3 – 14 days, however in most cases this period is generally 4 to 7 days.<sup>91</sup> Patients typically suffer from a sudden onset of fever, headache and pain around the eyes, muscular pain, tenderness, neuralgic joint pain and in some cases bleeding complications. Dengue fever patients can expect a slow but full recovery.<sup>88,91</sup>

DENV occurs in four serotypes (DENV-1, DENV-2, DENV-3, DENV-4)<sup>92,93</sup>, and infection by any of the four serotypes of DENV confers lifelong immunity to that particular serotype, as well as serotype cross-reactive immunity early after the primary infection. However, this broad protection rapidly decreases after 6 months and patients become again susceptible to the other three serotypes of the virus.<sup>94</sup> Several forms of dengue fever require immediate medical treatment, but unfortunately many of the affected areas lie in underdeveloped and/or poor, rural and highly populated regions of the world.

There are currently no therapeutic agents available against DENV, thus the most efficient measure against dengue is still prevention by vector control. The *Aedes* mosquitoes must be controlled in and around the home as this is where most transmission occurs. While insecticide surface sprays can kill adult mosquitoes, the most effective vector control occurs when the mosquitoes are still larval.<sup>95</sup> The risk of infection for travelers to tropical regions of the world is greatly reduced through personal protection with clothing and diethylmetatoluamide repellent for exposed skin.<sup>95</sup> Vaccine development against dengue fever has proven difficult, since an ideal vaccine candidate must be free from significant side effects, effective against all four serotypes of DENV and provide lifelong immunity.<sup>88</sup> An economical vaccine should also be favorable for dissemination in developing countries.

### **3.1.2 Molecular mechanism of infection**

Similar to other viruses the infection with DENV is initiated by the interaction of viral adhesive proteins with specific receptors expressed on the host cell surface.<sup>96</sup> DENV has a relatively simple structure, the envelope glycoprotein (EGP) is the major structural protein

exposed on the surface. In fact, mammalian host cell infection by the virus is mediated by EGP, which is known to be involved in the attachment of the virus to the host cell surface and engagement of fusion between the viral and the host cell membranes.<sup>97,98</sup> The crystal structure of DENV EGP was solved in 2003 revealing that EGP consists of three functional domains (DI, DII and DIII), which form a dimer on the surface of the virus particle and a transmembrane anchor.<sup>99</sup> In the crystal structure a ligand binding pocket at the interface of DI and DII was identified, which opens through a conformational shift in EGP and accepts hydrophobic moieties. Furthermore, it has been established that DIII mediates host cell surface receptor binding and therefore infection.<sup>100</sup>

Many viruses use carbohydrates as a first point of interaction during host invasion. The highly sulfated and negatively charged glycosaminoglycan (GAG) heparan sulfate (HS) expressed on mammalian cell surfaces has been implicated as a major determinant in DENV infection of mammalian cells.<sup>101-104</sup> It has been suggested that GAGs function to aggregate virus particles to the cell surface.<sup>105</sup> According to this, heparan sulfate enhances the interaction of the virus with the receptor rather than to bind the virus particles directly. Heparan sulfate (HS) is very closely related in structure to heparin (H). Both of them are heterogeneous, anionic polysaccharides (Figure 5). The linear carbohydrate chain in H/HS consists of alternating hexuronic acid and D-glucosamine units. The hexuronic acid is either D-glucuronic acid (D-GlcA) or its C-5 epimer, L-iduronic acid (L-IdoA). D-Glucuronic acid is linked by a  $\beta$ -(1 $\rightarrow$ 4) linkage, while L-iduronic acid is linked by a  $\alpha$ -(1 $\rightarrow$ 4) linkage to the D-glucosamine unit. The linkage between D-glucosamine and the uronic acid is  $\alpha$ -(1 $\rightarrow$ 4).<sup>106</sup> The heterogeneity results mostly from the substitution pattern of the carbohydrate backbone: O-3 and O-6 of D-glucosamine, as well as the O-2 of the uronic acids may be sulfated. The amino group of D-glucosamine may be free, *N*-acetylated or *N*-sulfated.

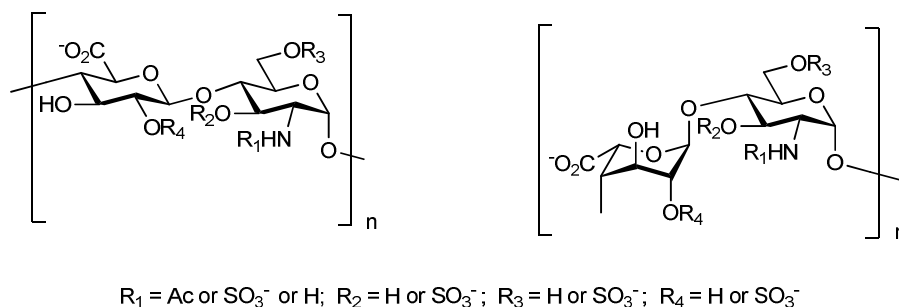
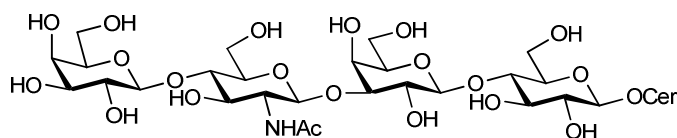

**Figure 5** Structure of H/HS

In the HS approximately half of the glucosamine units are sulfated. The *N*-sulfated disaccharides are usually located side by side in a 3-9 disaccharide residue domain (S-domain).<sup>107</sup> The structure of the S-domain is similar to heparin, however, less *O*-sulfated groups can be found. The S-domain usually alternates with non-sulfated GlcpA-GlcpNAc units. The heparan sulfate consists of one sulfate group in a disaccharide residue and the average molecule weight is 30 kDa.<sup>108</sup> In the non-sulfated region of HS the D-glucuronic acid dominates.

However, flaviviral research has suggested that an alternative and less abundant host cell receptor also exists. Previous studies have identified a range of protein species in addition to HS as proposed mammalian cell surface receptor molecules.<sup>109</sup> Kazuya Hidari *et al.* identified an association between all four serotypes of DENV and the mammalian cell surface glycolipid Paragloboside.<sup>110</sup> This glycoconjugate consists of the neutral tetrasaccharide Gal $\beta$ (1-4)GlcNAc $\beta$ (1-3)Gal $\beta$ (1-4)Glc $\beta$  (Lacto-*N*-neotetraose, nLc<sub>4</sub>, LNnT) and a hydrophilic ceramide (Cer) moiety that anchors it to the cell membrane (Figure 6). Interestingly, this tetrasaccharide glycan occurs in its free form as an important component of the oligosaccharide fraction of human milk.<sup>111</sup> There is strong evidence that the oligosaccharides of human milk exhibit anti-adhesive properties and thereby contribute to the protection of an infant from infectious pathogens,<sup>112</sup> a role that has also directly been attributed to the Paragloboside glycan LNnT.<sup>113</sup> Moreover, Paragloboside plays a role in some additional biological recognition events.<sup>114,115</sup>





**Figure 6** Structure of nLc<sub>4</sub>Cer

Some preliminary studies on elucidating the minimal determinant for nLc<sub>4</sub> binding to DENV-2 EGP suggested that the non-reducing terminal Gal $\beta$ (1-4)GlcNAc $\beta$ - disaccharide may be a critical determinant for the binding of DENV-2. However, this study was limited by the available structures.<sup>110</sup> Most recently, Kazuya Hidari *et al.* reported that the  $\beta$ -GlcNAc residue may play an important role in dengue virus binding to the host cell surface.<sup>116</sup>

Apparently, chemical synthesis of oligosaccharides is an essential and valuable tool to study carbohydrate-virus interactions in detail. Not only does chemical synthesis allow for elucidating the structural binding motifs, but it may contribute directly to the development of effective inhibitory ligands, that may find therapeutic applications.

### 3.1.3. Synthesis of oligosaccharides

Oligosaccharide synthesis is a challenge in carbohydrate chemistry due to the wide variety of complex structures that occur in nature and derive from the huge number of possible combinations and linkages between the different carbohydrate building blocks. In contrast to linear peptide and oligonucleotide synthesis, where automatization was developed many years ago, synthetic parameters for oligosaccharide synthesis typically have to be tailored and tuned to each targeted oligosaccharide structure. Principally, the chemical synthesis of oligosaccharides consists of the following steps:<sup>117</sup>

- Synthesis of a glycosyl acceptor: a glycosyl acceptor needs to be partially protected in order to have free hydroxyl (OH) group(s) at the desired position(s) for the attachment of the donor.
- Synthesis of a glycosyl donor: a glycosyl donor needs to contain a leaving group (LG) at the anomeric position which can be activated.
- Regio- and stereoselective glycosylation with a glycosyl donor and a glycosyl acceptor.

- Selective removal of the protecting groups in the presence of the glycosidic linkage and other functional groups.

To cite Hans Paulsen, one of the pioneers of oligosaccharide synthesis: “Each oligosaccharide synthesis remains an independent problem, whose resolution requires considerable systematic research and a good deal of know-how. There are no universal reaction conditions for oligosaccharide syntheses.”<sup>118</sup>

The key step in oligosaccharide synthesis is the formation of the glycosidic bond. A number of molecular factors can influence the course of the glycosylation reaction:

- Configurational nature of the glycosyl donor
- Nature of the protecting groups of the donor
- Type of selected leaving group
- Type of the promoter used for activation of the donor
- Solvent
- Nature of the glycosyl acceptor

Several functional groups employed for glycosyl donors are widely known, which require different promoters. Nowadays the most common glycosyl donors are the glycosyl halides, thioglycosides, imidates (i.e. Schmidt’s trichloroacetimidates), 4-pentenyl glycosides and phosphates. In the following, thioglycosides and glycosyl bromides are described as glycosyl donors since they are employed in the research described in this chapter.

#### **3.1.4. Thioglycosides**

Thioglycosides are some of the most commonly used glycosyl donors in the synthesis of oligosaccharides. In general, thioglycosides have several advantages over other types of glycosyl donors: they are cheap to prepare, stable when stored and can be activated by thiofilic reagents under mild conditions.

The first thioglycosides were prepared from acetobromosugars with thiolate anions.<sup>119</sup> According to the most recent method, 1,2-*trans* acetylated aldoses are reacted with a small excess of the thiol in the presence of hard Lewis acids (e.g.  $\text{BF}_3 \cdot \text{Et}_2\text{O}$  or  $\text{SnCl}_4$ ).<sup>120</sup> Owing to

the participating acetyl group at C-2, the configuration of the product is predominantly 1,2-*trans*, while using a less reactive precursor the product can undergo anomerization due to the longer reaction time. However, the resulting 1,2-*cis* impurity can often be removed by crystallization. Thioglycosides can also be synthesized from trichloroacetimidates,<sup>121</sup> 1,2-anhydro sugars<sup>122</sup> and hemiacetals.<sup>123</sup>

Importantly, the thioglycoside function is stable under the conditions of most protecting group manipulations, and this strongly supports the use of thioglycosides in several synthetic strategies. In addition, thioglycosides are not only used as glycosyl donors but also as glycosyl acceptors because the thioglycosidic linkage tolerates several conditions of alternative glycosylation methods. All these features make thioglycosides important in the chemical synthesis of complex oligosaccharides.

Thioglycoside glycosyl donors can be activated by soft electrophilic reagents (Scheme 31). These reagents react with the soft nucleophilic sulfur generating a sulfonium ion, which is an excellent leaving group. The departure of the sulfonium ion gives rise to an oxocarbenium ion intermediate, from which the *O*-glycoside is formed.

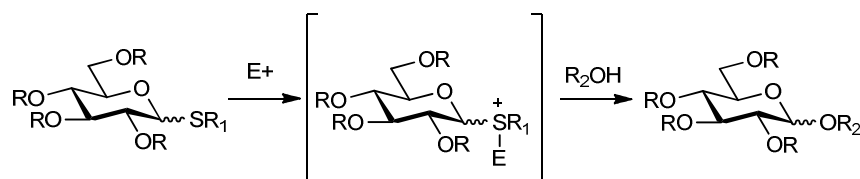

**Scheme 31** Activation of thioglycosides

The first method for thioglycoside activation was introduced by Ferrier by means of the  $\text{HgSO}_4$  promoter.<sup>124</sup> Later, other heavy metal salts have also been employed, but due to their limited effect only low yields could be achieved. The first glycosylation with a viable yield was achieved by Lönn using methyl trifluoromethanesulfonate (MeOTf) as the promoter.<sup>125</sup> Thioglycosides can also be activated by electrophiles containing sulfur by forming a sulfur-sulfur bond. Fügedi introduced dimethyl-(methylthio)-sulfonium triflate (DMTST) as an effective promoter, which can be synthesized in the reaction of dimethyl disulfide and methyl triflate.<sup>126,127</sup> Moreover, thioglycosides can be efficiently activated by halides as well as *N*-bromosuccinimide (NBS) or *N*-iodosuccinimide (NIS).<sup>128</sup> Lately, the use of NBS/NIS in the

presence of a Lewis acid has been the most common way for thiodonor activation, since they are convenient to handle.

### 3.1.5. Glycosyl bromides

In 1901 Koenigs and Knorr published a synthesis of glycosides with glycosyl bromides and alcohols in the presence of  $\text{Ag}_2\text{CO}_3$  promoter (Scheme 32).<sup>129</sup>

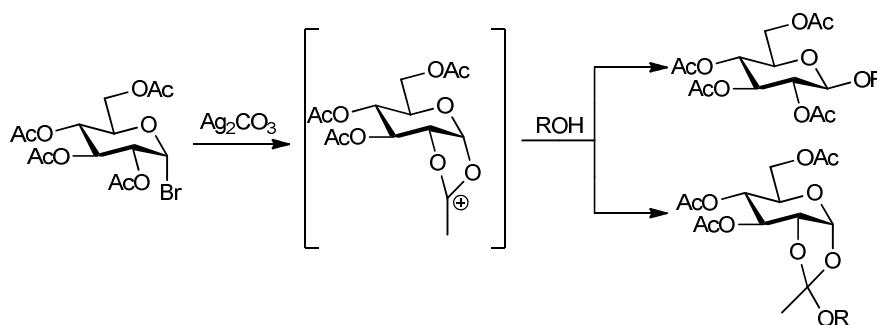

**Scheme 32** Koenigs Knorr reaction

In accordance with the participating acetyl group at C-2 the peracetylated glucopyranosyl bromide provides the 1,2-*trans* glycoside. Due to the involvement of the neighbouring group, an acyloxonium ion is formed which shields one side of the anomeric center, so the anomeric carbon can only be attacked by the nucleophile from the other side to afford the 1,2-*trans* glycoside. However, during the Koenigs-Knorr glycosylation orthoester formation can also occur.<sup>130</sup> Later,  $\text{Ag}_2\text{O}$  as a promoter was introduced. During the glycosylation reaction promoted by  $\text{Ag}_2\text{O}$  or  $\text{Ag}_2\text{CO}_3$  water is generated resulting in low yield. However, addition of drying agents such as molecular sieves or  $\text{CaSO}_4$  (Drierite)<sup>131</sup> to the reaction mixture can improve the yield.

Moreover, Zemplén applied  $\text{Hg}(\text{OAc})_2$  as a promoter,<sup>132</sup> while Helferich introduced the  $\text{Hg}(\text{CN})_2$  and  $\text{HgBr}_2/\text{Hg}(\text{CN})_2$  promoters.<sup>130,133</sup> Of further significant importance was the introduction of silver triflate ( $\text{AgOTf}$ ).<sup>134</sup>

For the synthesis of  $\alpha$ -1,2-*cis* glycosides an *in situ* anomerisation method has been developed.<sup>135</sup>  $\alpha$ -Glycosyl bromides with a non-participating group at C-2 can be transformed

to  $\beta$ -glycosyl bromides. The reaction is catalyzed by halide ions from tetrabutyl-ammonium bromide. Although the concentration of the  $\beta$ -glycosyl bromide is low due to the anomeric effect, it reacts very fast with alcohols to form  $\alpha$ -glycosides via inversion of configuration (Scheme 33).

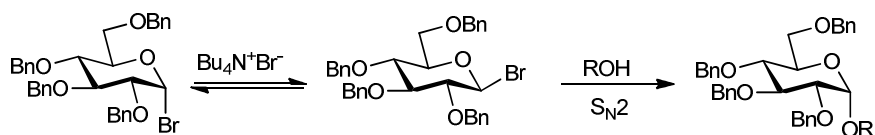

**Scheme 33** In situ anomerisation

Non-soluble silver salts (e.g. Ag-silica) are used to synthesize  $\beta$ -mannosides (Scheme 34).<sup>136</sup> The  $\alpha$ -side is shielded by the non-soluble promoter, enabling the nucleophile to attack the anomeric center from the other side, affording a  $\beta$ -1,2-*cis* glycoside. However, the reaction can only be carried out with reactive glycosyl bromides and reactive glycosyl acceptors, and this method is not completely stereoselective.

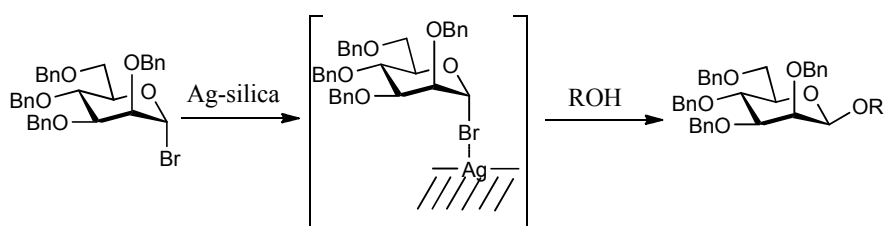

**Scheme 34** Synthesis of  $\beta$ -mannosides

### 3.2. Aim of the project

DENV infection of mammalian cells appears to be a complex multi-step process and research has identified a role for several mammalian cell surface structures, including some glycans. As outlined in Chapter 3.1.2, both GAG heparan sulfate and the nLc<sub>4</sub> tetrasaccharide have been shown to inhibit DENV infection, however these studies were limited by the available structures. Furthermore, it should be noted that the sub-domain of EGP that interacts with nLc<sub>4</sub> is still unidentified and therefore its precise mode of action still remains undefined.

At the Institute for Glycomics directed by Mark von Itzstein in Australia intensive research has been performed to investigate the DENV-2 EGP DIII ligand specificity and characterization of the DIII domain involved in mammalian cell infection. In fact, applying modern functional glycomics tools previous studies have confirmed that the nLc<sub>4</sub> tetrasaccharide binds to the DIII domain. Moreover, epitope mapping revealed that the *N*-acetyl-D-glucosamine (GlcNAc) unit makes the closest contact with the DIII domain via its *N*-acetyl group. Several EGP-ligand interactions were observed by screening available carbohydrate libraries that share the GlcNAc moiety at the first or the second position of their non-reducing end.

The identification of putative receptors for DENV requires the synthesis of a range of nLc<sub>4</sub>-related glycan structures. Based on the facts mentioned above, the GlcNAcβ(1-3)Galβ(1-4)GlcNAc trisaccharide raised our particular interest. Therefore, we decided to synthesize the GlcNAcβ(1-3)Galβ(1-4)GlcNAc trisaccharide **18** for further biological studies (Figure 7).

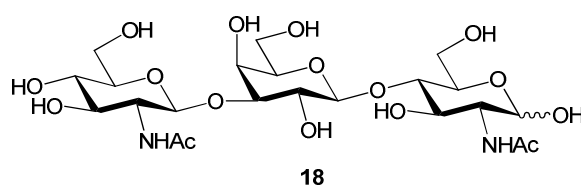

**Figure 7** Structure of GlcNAcβ(1-3)Galβ(1-4)GlcNAc trisaccharide

Furthermore, a library of H/HS oligosaccharide fragments may also be a useful tool to study DENV inhibition and it may determinate the minimum structure in the polysaccharide chain which is responsible for the biological activation. Therefore, we decided to prepare a

series of target HS fragments for further biological investigation. For this reason the aim of the second project was to develop an efficient method for the synthesis of a D-glucuronic acid thioglycoside, which can be employed as a glycosyl donor for the synthesis of HS oligosaccharides.

### 3.3. Results and discussion

#### 3.3.1. Retrosynthetic plan for the GlcNAc $\beta$ (1-3)Gal $\beta$ (1-4)GlcNAc trisaccharide

The preceding chapters highlight the growing interest in the identification of putative DENV receptors that require the synthesis of a range of nLc<sub>4</sub>-related glycan structures believed to be of particular interest for further biological studies. In the context of the aforementioned studies especially the GlcNAc $\beta$ (1-3)Gal $\beta$ (1-4)GlcNAc trisaccharide occurred to be an ideal starting point to develop potential virus receptor mimics.

Several strategies can be designed for the synthesis of the target trisaccharide **18**. In the literature only one procedure is described, in which the condensation of **19** with **20** in boiling benzene and in the presence of mercuric cyanide (Hg(CN)<sub>2</sub>) afforded the trisaccharide **21**, followed by deprotection to result in the trisaccharide **18** (Scheme 35).<sup>137</sup>

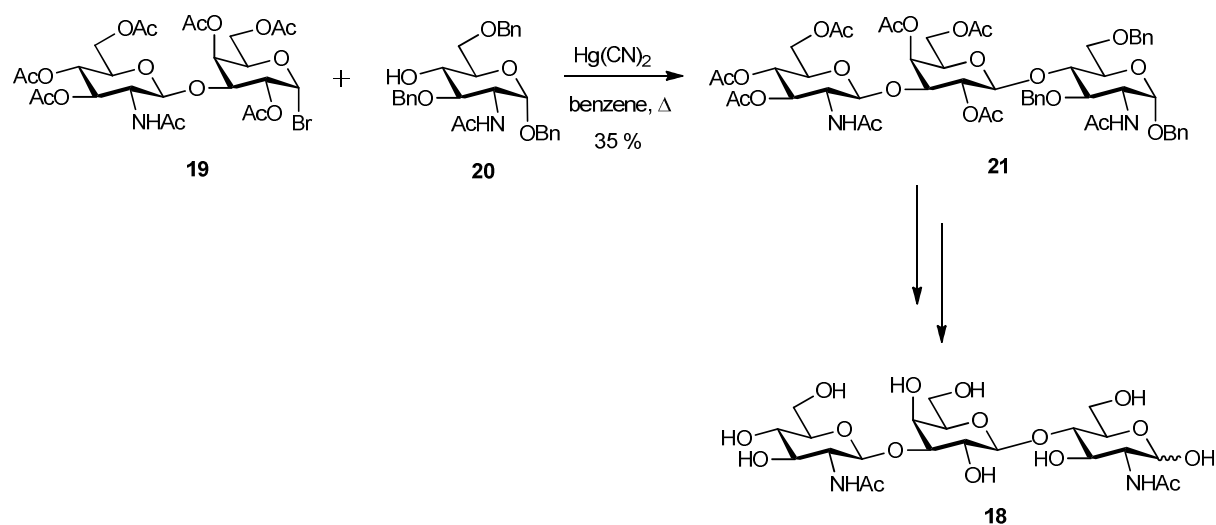

**Scheme 35** Synthesis of GlcNAc $\beta$ (1-3)Gal $\beta$ (1-4)GlcNAc trisaccharide according to Kushi *et al.*

The disaccharide at the reducing end is known as lactosamine consisting of D-galactose (Gal) and D-glucosamine (GlcNAc) linked by a  $\beta$ (1 $\rightarrow$ 4) bond. In fact, the lactosamine unit is essential for the synthesis of nLc<sub>4</sub> and other related compounds, hence a number of lactosamine derivatives have already been prepared in the von Itzstein's research group. Thus, it appeared of strategic advantage to assemble the desired trisaccharide **18** by coupling a



D-glucosamine donor with a set of lactosamine acceptors, followed by easy deprotection. However, *N*-acetyl glycosyl donors are not suited for the synthesis of 1,2-*trans* glycosides. During the glycosylation these compounds can be transformed into oxazoline intermediates, which can only react with highly reactive glycosyl acceptors due to their low reactivity (Scheme 36).

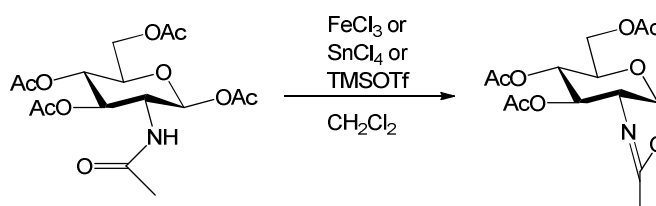

**Scheme 36** Formation of 1,2-oxazoline

Therefore, the amino groups need to be protected by another amide type protecting group, which is less stable and can still act as a participating group at C-2. In this way, a more reactive oxazoline intermediate is generated, from which the desired 1,2-*trans* glycoside can be formed. Based on this consideration we decided to synthesize the protected trisaccharide **22** or **23** by the coupling of the glycosyl donor **24** and the glycosyl acceptor **25** or **26** (Scheme 37).

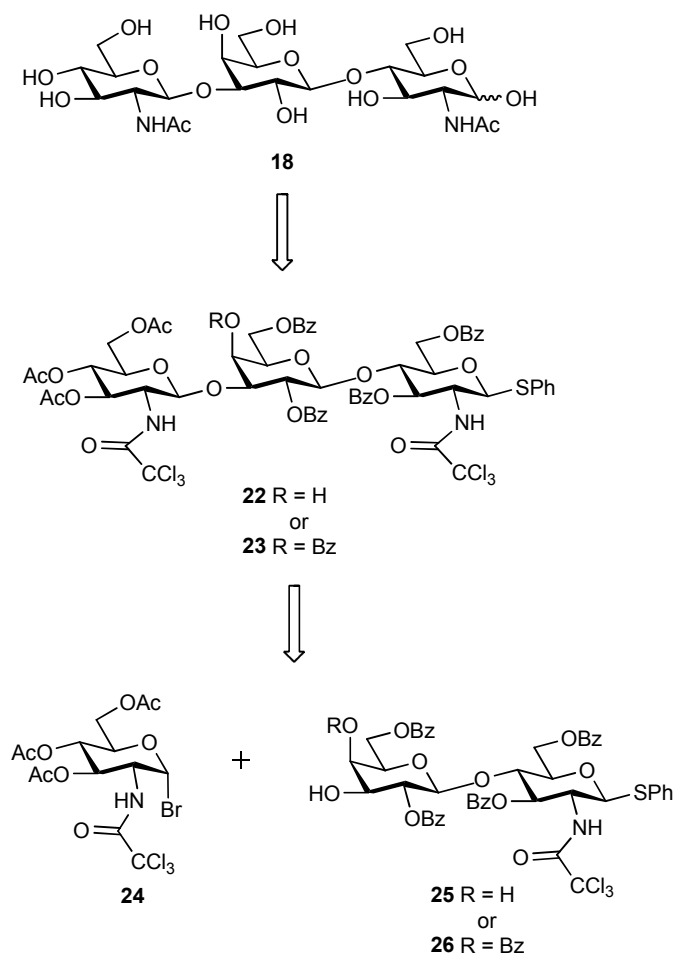

**Scheme 37** Retro synthetic plan for the GlcNAc $\beta$ (1-3)Gal $\beta$ (1-4)GlcNAc trisaccharide

According to our retro synthetic plan, the amino groups are protected by trichloroacetyl (TCA) groups. The anomeric center of the acceptor is masked with a thiophenyl (SPh) group, while the anomeric position of the donor is halogenated. Thus, the protected trisaccharide can also be used as a donor for the synthesis of other nLc<sub>4</sub>-related derivatives. In fact, the equatorial O-3' position of the acceptor is significantly more reactive than the axial O-4' position, and diol **25** is therefore a conceivable candidate as an acceptor in the glycosylation reaction. Otherwise, the O-4' position can be selectively protected via orthoester formation to afford the corresponding glycosyl acceptor **26**. Moreover, the hydroxyl groups on the donor are acetylated (Ac), while the hydroxyl groups of the acceptor are protected by benzoyl (Bz) groups.

### 3.3.2. Synthesis of the glycosyl donor

In fact, the tetraacetate **31** can be prepared in two steps: protection of the amino group in **27** by the trichloroacetyl group, followed by acetylation of the hydroxyl groups.<sup>138</sup> However, when this method was attempted for the synthesis of **31**, trichloroacetyl chloride reacted with methanol (used as a solvent) much faster than with the carbohydrate. Thus, the resulting yield was rather poor, and therefore these conditions were not suited for the first step. In addition, the obtained *N*-trichloroacetylglucosamine was difficult to purify. Therefore, we decided to prepare **24** by using a five-step method (Scheme 38).<sup>139</sup>

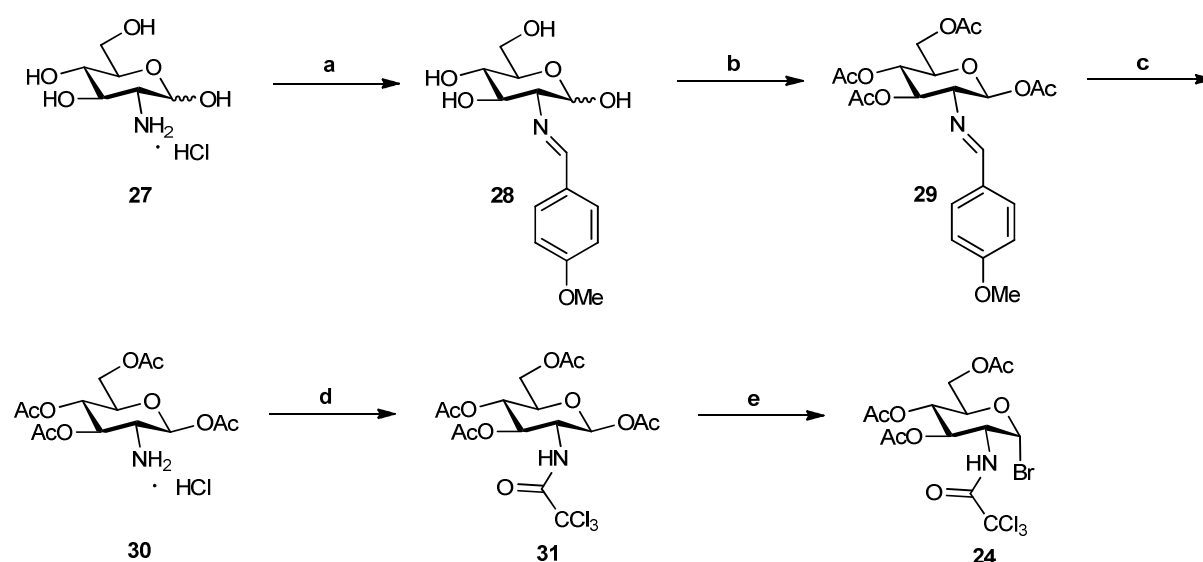

**a:** 4-methoxybenzaldehyde, 1 M NaOH (81%); **b:** Ac<sub>2</sub>O, pyridine (85%); **c:** aq. HCl, acetone (90%);  
**d:** trichloroacetyl chloride, Et<sub>3</sub>N, CH<sub>2</sub>Cl<sub>2</sub> (79%), **e:** TMSBr, CH<sub>2</sub>Cl<sub>2</sub> (98%)

**Scheme 38** Synthesis of the glycosyl donor

The starting material for the preparation of the donor was commercially available D-glucosamine hydrochloride (**27**). First, the amino group was selectively protected with the 4-methoxybenzylidene group using 4-methoxybenzaldehyde in aqueous sodium hydroxide solution. Then the hydroxyl groups were acetylated, followed by cleavage of the benzylidene group with aq. HCl in acetone. At this point **30** was reacted with trichloroacetyl chloride in the presence of triethylamine to afford the *N*-trichloroacetylglucosamine derivative **31**. Glycosyl bromides are usually not very stable and can decompose easily during the work up.

To avoid this, **31** was treated with trimethylsilyl bromide (TMSBr) in CH<sub>2</sub>Cl<sub>2</sub>, the reaction mixture was then evaporated *in vacuo* to afford the desired compound **24** as a white foam.

### 3.3.3. Synthesis of the glycosyl acceptor

A lactosamine derivative was chosen as glycosyl acceptor since a number of lactosamine derivatives have been already prepared in the von Itzstein's group. The selected starting material **32** has been previously synthesized in large scale from lactulose by the Heyns rearrangement<sup>140</sup>, followed by various protecting group manipulations (Scheme 39).

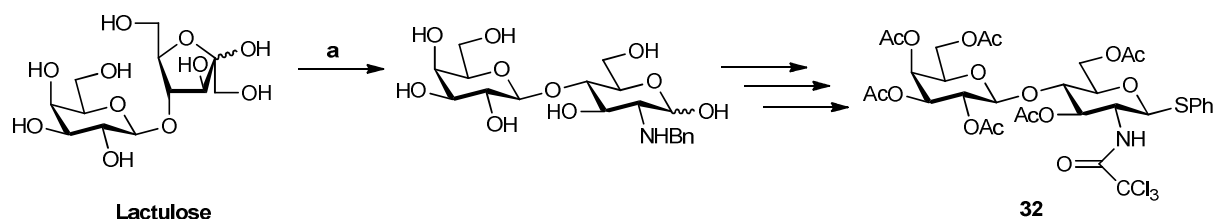

**a:** *BnNH<sub>2</sub>*, *AcOH*, *MeOH* (65 – 70 %)

**Scheme 39** Heyns rearrangement

The first step of our synthesis was the cleavage of the acetyl groups on **32** by Zemplén deacetylation. To selectively protect the O-3' and O-4' positions of **33** the isopropylidene group was introduced using 2,2-dimethoxypropane in *N,N*-dimethylformamide (DMF) at room temperature in the presence of camphorsulfonic acid (CSA). However, a mixture of the 3',4'-*O*- (thermodynamically controlled product) and 4',6'-*O*-isopropylidene derivatives (kinetically controlled product) was obtained. To favor the thermodynamic product the temperature was increased to 80 °C, but the reaction still gave a mixture of the two lactosamine acetal derivatives, from which the desired 3',4'-*O*-isopropylidene derivative **34** could be separated in 46% yield by column chromatography.

Joachim Thiem *et al.* reported an efficient and simple method for the 3',4'-*O*-isopropylidation of β-lactosides by the use of trimethylsilylchloride (TMSCl) and acetone at room temperature.<sup>141</sup> According to the reported procedure a suspension of **33** in a mixture of acetone and 10 equivalents of TMSCl was stirred at room temperature for 3 hours and

concentrated to afford product **34** exclusively. It should be noted that the same result was obtained using only 0.5 equiv. TMSCl instead of 10 equivalents.

It is known that benzoyl groups show a lower tendency for migration than acetyl groups. Thus, without isolation or purification, compound **34** was subjected to benzoylation by means of benzoyl chloride in pyridine to afford **35**. The isopropylidene group was then removed by 90% aqueous trifluoroacetic acid (TFA) to furnish the desired compound **25** (Scheme 40).

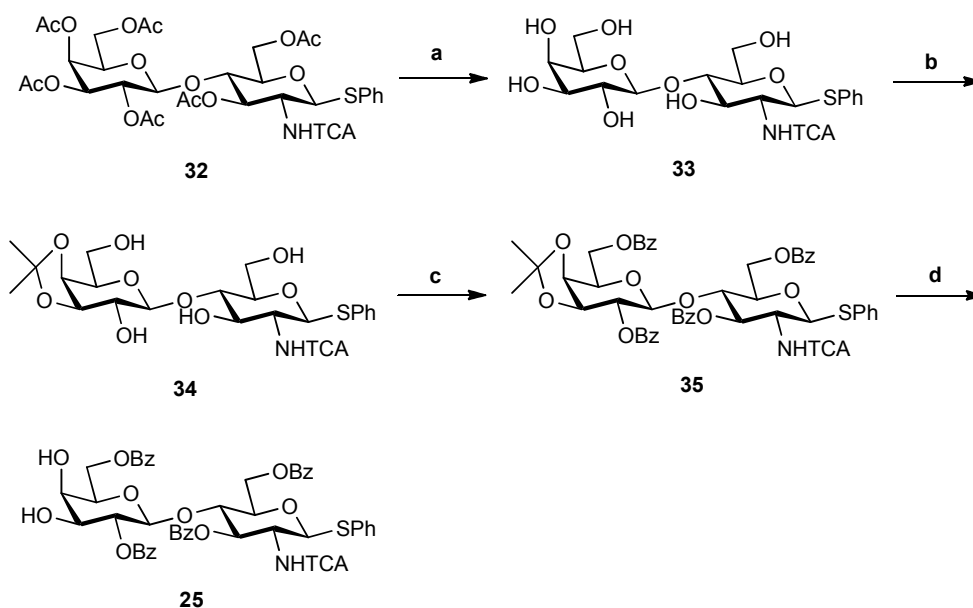

**a:** NaOMe, MeOH (~100%); **b:** acetone, TMSCl; **c:** BzCl, pyridine (78%); **d:** aq. TFA, CH<sub>2</sub>Cl<sub>2</sub> (91%)

**Scheme 40** Synthesis of the diol glycosyl acceptor

Based on the known reactivity difference between the O-3' and the O-4' position of the galactose unit, diol **25** was expected to be eligible for regioselective glycosylation. However, in our case selective protection of the O-4' position turned out to be required for successful coupling, as will be described in the next chapter (chapter 3.3.4).

A well-known process for regioselective protection of the O-4 position of D-galactose derivatives (leaving the O-3 position free) is orthoester formation followed by selective opening. The orthoester ring is not stable under acidic condition, thus it can be easily opened to the axial O-4 position in the reaction mixture (*in situ*). Therefore, the diol **25** was transformed into the 3',4'-O-orthoester intermediate **36** by means of trimethyl orthobenzoate

in the presence of *p*-toluenesulfonic acid (*p*TsOH). Then **36** was treated with acetic acid (AcOH) to afford the corresponding 4'-*O*-benzoyl derivative **26** (Scheme 41).

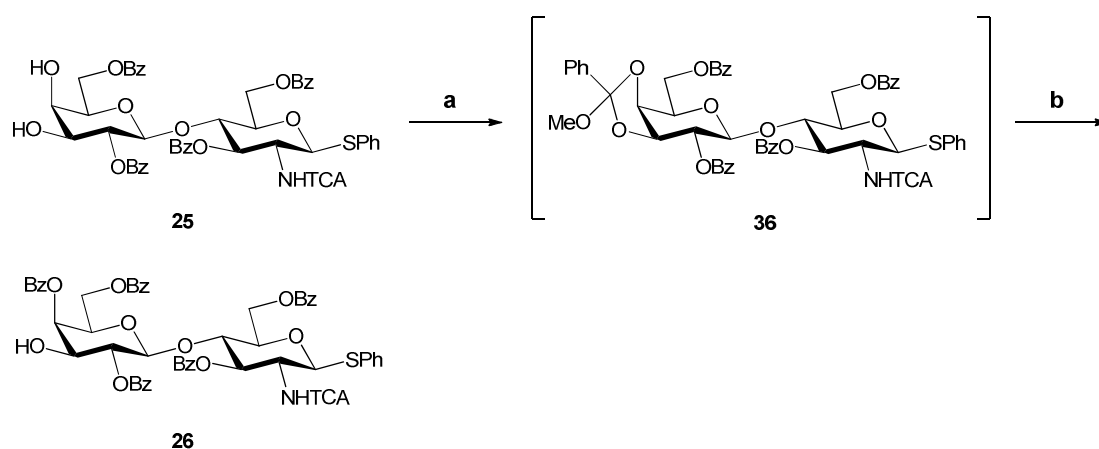

**Scheme 41** Orthoester formation and selective ring opening

### 3.3.4. Glycosylation

Having the desired donor and acceptor at hand we turned our attention to the crucial glycosylation reaction. The coupling of the diol acceptor **25** with an excess of the donor **24** promoted by silver triflate (AgOTf) at -20 °C resulted in a mixture of the two trisaccharides **22** and **37** and the tetrasaccharide **38**. (Scheme 42, pathway a). Surprisingly, employing an excess of the acceptor **25** the glycosylation reaction still afforded the mixture of the two corresponding trisaccharides (**22** and **37**), from which the desired compound **22** could not be separated in pure form by column chromatography (Scheme 42, pathway b).

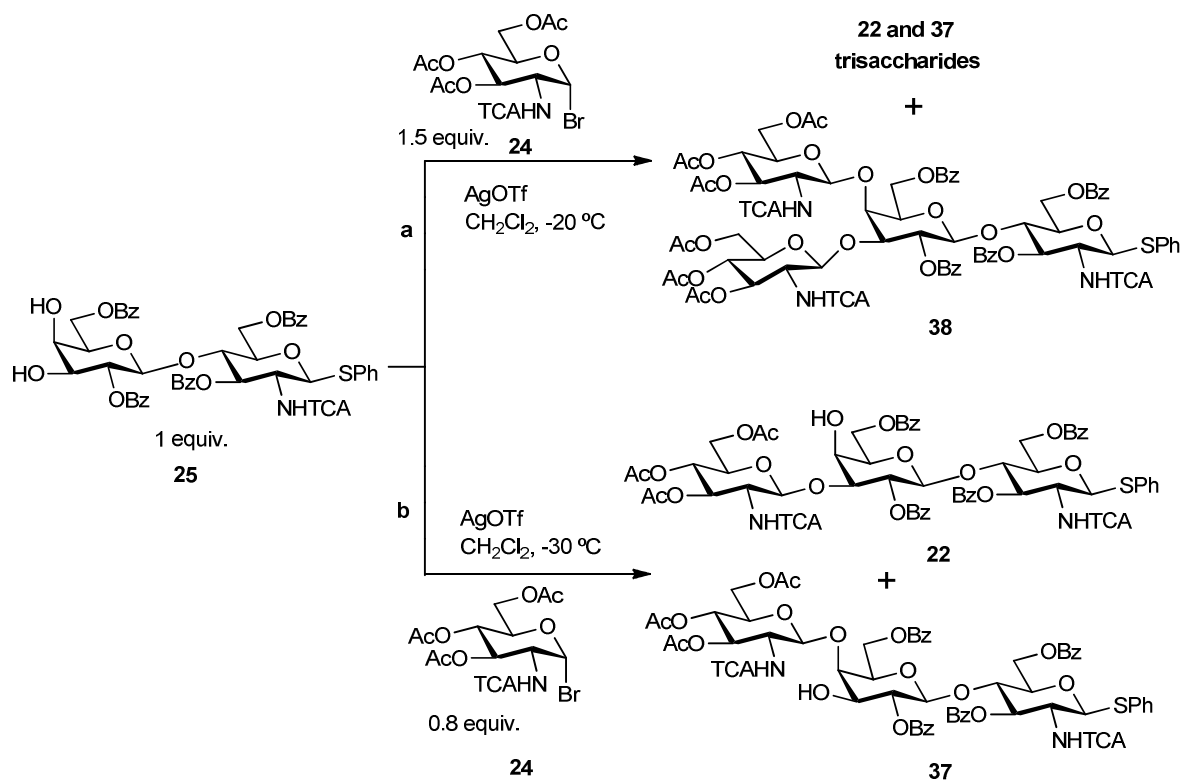

**a:** 1.5 equiv. donor, AgOTf, CH<sub>2</sub>Cl<sub>2</sub>, -20 °C; **b:** 0.8 equiv. donor, AgOTf, CH<sub>2</sub>Cl<sub>2</sub>, -30 °C

**Scheme 42** Glycosylation with the diol acceptor

This indicates that, in spite of the reactivity difference between the O-3' and the O-4' position of the glycosyl acceptor, the regioselective glycosylation could not be achieved, presumably due to high reactivity of the donor. Therefore, the protection of the O-4' position is required and the acceptor **26** was introduced for the crucial glycosylation reaction. The reaction of the acceptor **26** and the donor **24** (1.5 equiv.) promoted by AgOTf at -30 °C in CH<sub>2</sub>Cl<sub>2</sub> proceeded smoothly and the desired trisaccharide **23** was isolated in 71% yield (Scheme 43).

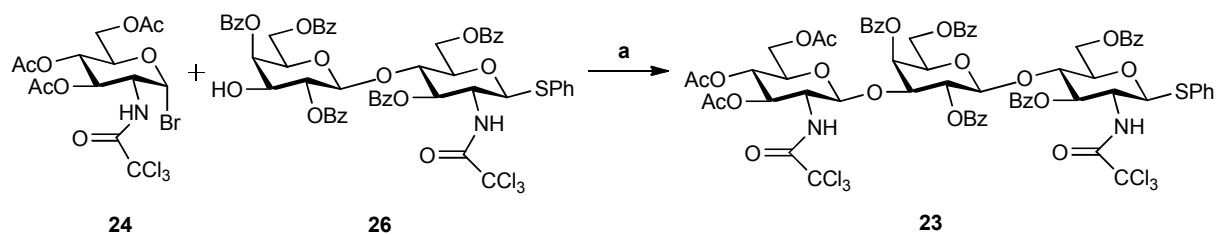

**a:** *AgOTf*,  $CH_2Cl_2$ ,  $-30^\circ C$  (71%)

**Scheme 43** Glycosylation reaction

### 3.3.5. Deprotection

To obtain the final disaccharide **18**, the protecting groups have to be removed and the amino groups needs to be acetylated. According to the literature<sup>142</sup> all acyl groups can be removed in a one-pot reaction, followed by the regioselective *N*-acetylation of the free amino groups. To this end **23** was treated with 20% aqueous NaOH at 40 °C, then Ac<sub>2</sub>O was added at 0 °C to afford the corresponding *N*-acetylated derivative **39**. By means of a mild and general method<sup>143</sup> the thiophenyl group was removed in wet acetone with *N*-bromosuccinimide (NBS) to result in the final deprotected trisaccharide **18** as an anomeric mixture (Scheme 44). The synthesized deprotected trisaccharide is currently under further investigation for biological activity and binding properties.

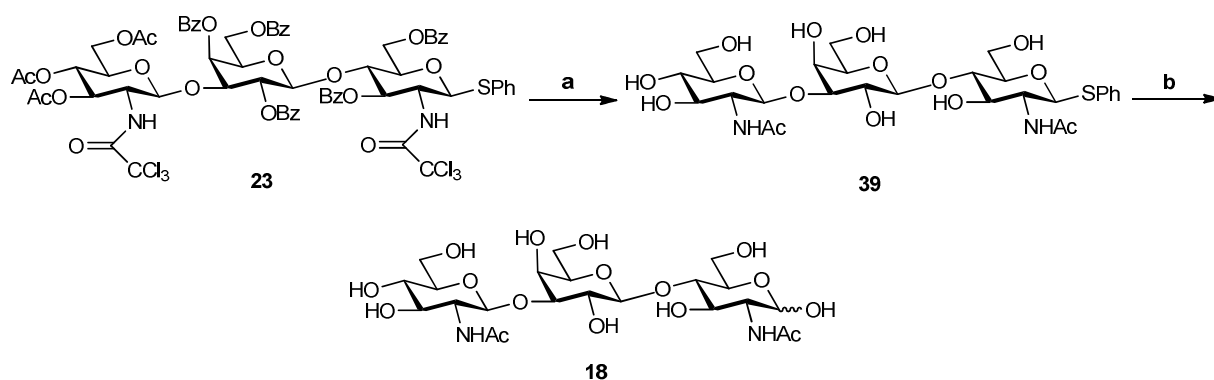

**a:** (i) NaOH, MeOH/H<sub>2</sub>O, 40 °C; (ii) Ac<sub>2</sub>O (76%); **b:** NBS, acetone/H<sub>2</sub>O (63%)

**Scheme 44** Synthesis of the deprotected GlcNAcβ(1-3)Galβ(1-4)GlcNAc trisaccharide



### 3.3.6. Strategy for the synthesis of heparan sulfate oligosaccharides

In the literature several methods are well known for the synthesis of H/HS oligosaccharides.<sup>144-148</sup> The first strategy was reported by Sinaÿ and co-workers.<sup>149,150</sup> The hydroxyl groups of the protected derivative to be sulfated were protected by acetyl groups, while the rest of the hydroxyl groups were blocked by benzyl groups. The limitations of this strategy are the large number of synthetic steps and the lack of flexibility, only one final product can be synthesized from one single precursor.

Fügedi and Tatai have reported a strategy based on orthogonal protection of the positions for which sulfation is optional in the target compounds.<sup>151</sup> This strategy allows the synthesis of a series of sulfated final compounds from a common protected intermediate (Scheme 45).

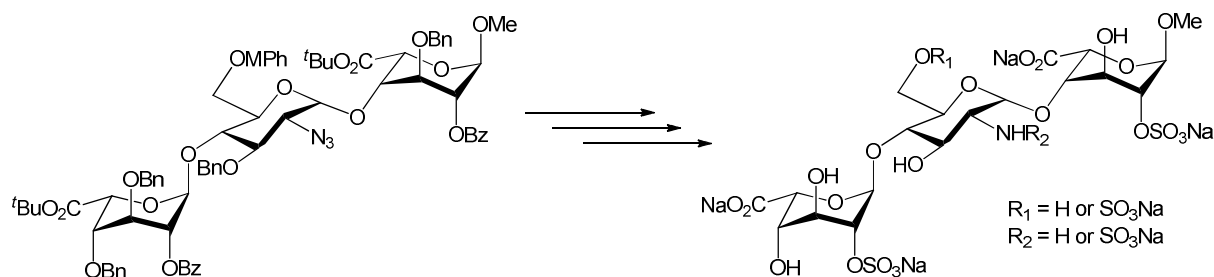

**Scheme 45** Orthogonal protecting strategy by Fügedi

Inspired by Fügedi's work we intended to prepare an orthogonally protected HS fragment, from which multiple target compounds could be synthesized, and that could be used for further syntheses of HS oligosaccharides (Scheme 46).

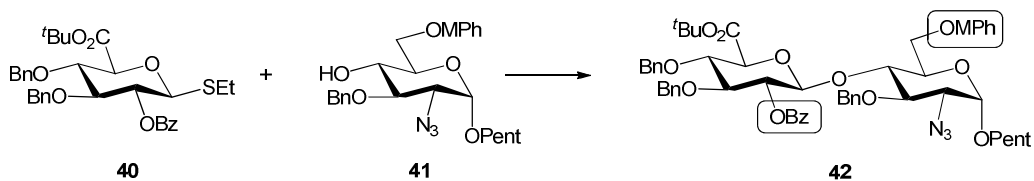

**Scheme 46** Orthogonally protected HS fragment

Accordingly, the target disaccharide **42** was orthogonally protected by means of a benzoyl (Bz) group at the O-2 position of the glucuronic acid and a *p*-methoxyphenyl (MPh) at the O-

6 position of the glucosamine residue. The reducing end of the disaccharide is protected with a 4-pentenyl (Pent) group which can be selectively activated to become an excellent leaving group, thus, the disaccharide **42** can be used as a glycosyl donor for further synthesis of heparin oligosaccharides. For the synthesis of the desired orthogonally protected disaccharide a glucuronic acid donor **40** and a glucosamine acceptor **41** are required. Based on the aforementioned advantages of thioglycosides, we decided to develop an efficient procedure for the synthesis of  $\beta$ -D-glucuronic acid thioglycoside glycosyl donor **40**.

### 3.3.7. Synthesis of D-glucuronic acid glycosyl donor

Several chemical syntheses are reported in the literature for the synthesis of D-glucuronic acid derivatives.<sup>152-154</sup> An efficient synthetic method requires limited steps with viable yields. Wang *et al.* described a combinatorial, and highly regioselective method that can be used to protect individual hydroxyl groups of a monosaccharide.<sup>155</sup> This approach can be employed to install an orthogonal protecting group pattern in a single reaction vessel (a 'one-pot' reaction). Although this method eliminates the need to carry out the time-consuming isolation and purification of intermediates, it comes at the disadvantage that the reactions must be carried out at -86 °C.

Another method for a one-pot regioselective protection of carbohydrates was published in 2007, which has been optimized on D-glucopyranosides under mild reaction conditions by using a single catalyst in a single reaction vessel (Scheme 47).<sup>156</sup> In both publications the key intermediates are the corresponding per-*O*-trimethylsilylated derivatives which can be easily prepared. This latter method seemed to be a useful tool for the synthesis of the D-glucuronic acid glycosyl donor.

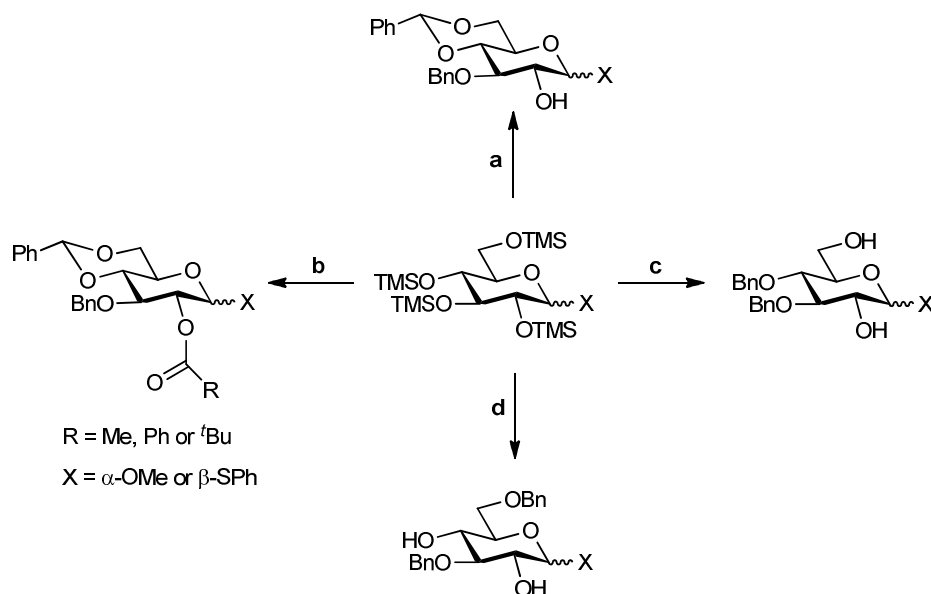

**a:** *PhCHO*, *Et<sub>3</sub>SiH*, *Cu(OTf)<sub>2</sub>*, *CH<sub>2</sub>Cl<sub>2</sub>/CH<sub>3</sub>CN* (4:1); **b:** *PhCHO*, *Et<sub>3</sub>SiH*, *Cu(OTf)<sub>2</sub>*, *CH<sub>2</sub>Cl<sub>2</sub>/CH<sub>3</sub>CN* (4:1), then *(RCO)<sub>2</sub>O*, *CH<sub>2</sub>Cl<sub>2</sub>*; **c:** *PhCHO*, *Et<sub>3</sub>SiH*, *Cu(OTf)<sub>2</sub>*, *CH<sub>2</sub>Cl<sub>2</sub>/CH<sub>3</sub>CN* (4:1), then *BH<sub>3</sub>·THF*, *Cu(OTf)<sub>2</sub>*; **d:** *PhCHO*, *Et<sub>3</sub>SiH*, *Cu(OTf)<sub>2</sub>*, *CH<sub>2</sub>Cl<sub>2</sub>/CH<sub>3</sub>CN* (4:1), then *Et<sub>3</sub>SiH*, *Cu(OTf)<sub>2</sub>*

**Scheme 47** Copper(II) triflate catalyzed one-pot regioselective reaction

For the preparation of the glucuronic acid thioglycoside **40** the starting material was the commercially available 1,2,3,4,6-penta-*O*-acetyl- $\beta$ -D-glucopyranose (**43**) (Scheme 48). It was converted to the thioglycoside by using *EtSH* in the presence of *BF<sub>3</sub>·Et<sub>2</sub>O* as a Lewis acid and the thioglycoside **44** was isolated in 76% yield. Next, the acetyl groups were removed by the Zemplén reaction and the compound **45** was reacted with *TMSCl* in pyridine (*Pyr*) in the presence of 4-(dimethylamino)pyridine (*DMAP*) to afford the corresponding per-*O*-trimethylsilylated thioglycoside **46**.

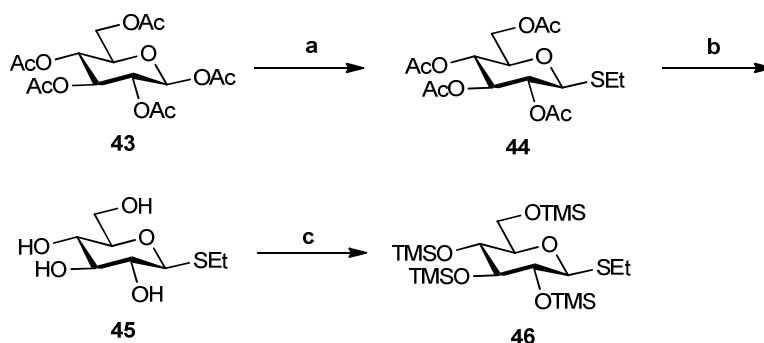

**a:** *EtSH*, *BF<sub>3</sub>·Et<sub>2</sub>O*, *CH<sub>2</sub>Cl<sub>2</sub>* (76 %); **b:** *NaOMe*, *MeOH* (~100%); **c:** *TMSCl*, *DMAP*, *Pyr* (80%)

**Scheme 48** Synthesis of the persilylated thioglycoside

Having the desired key intermediate at hand the crucial regioselective one-pot reaction was carried out next (Scheme 49). According to the literature<sup>156</sup> benzaldehyde and triethylsilane ( $\text{Et}_3\text{SiH}$ ) were added to the solution of **46** in  $\text{CH}_2\text{Cl}_2/\text{CH}_3\text{CN}$  (4:1) in the presence of 1 mol% copper(II) trifluoromethanesulfonate ( $\text{Cu}(\text{OTf})_2$ ) as a catalyst at  $0^\circ\text{C}$ . The reaction mixture was concentrated to dryness and the residue was subjected to benzylation without purification to afford the corresponding protected compound **47** in 62% yield.

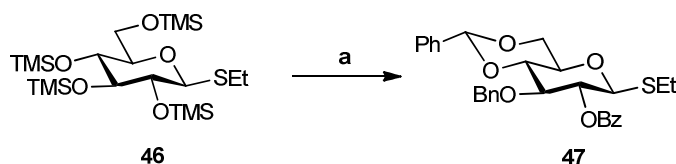

**a:**  $\text{PhCHO}$ ,  $\text{Et}_3\text{SiH}$ ,  $\text{Cu}(\text{OTf})_2$ ,  $\text{CH}_2\text{Cl}_2 / \text{CH}_3\text{CN}$  (4:1);  $\text{Bz}_2\text{O}$ ,  $\text{CH}_2\text{Cl}_2$ ,  $40^\circ\text{C}$  (62%)

**Scheme 49** Regioselective one-pot reaction

The 4,6-*O*-benzylidene acetal ring of **47** was reductively opened with 1 M borane tetrahydrofuran ( $\text{BH}_3\cdot\text{THF}$ ) and trimethylsilyl trifluoromethanesulfonate ( $\text{TMSOTf}$ ) to result in the 4-*O*-benzyl derivative **48** exclusively. Corey-Samuelsson oxidation<sup>157</sup> of **48** with pyridinium dichromate and acetic anhydride in the presence of *tert*-butanol gave the desired D-glucuronic acid thioglycoside **40** directly (Scheme 50). In the oxidation the intermediate aldehyde reacts with *tert*-butanol to give the hemiacetal which is then oxidized directly to the *tert*-butyl ester. It should be noted that during the oxidation step partial oxidation of sulfur to the corresponding sulfoxide and sulfone was not obtained.

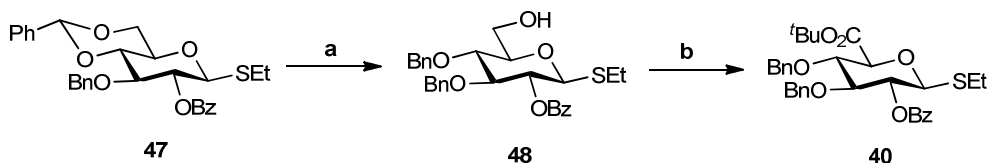

**a:** 1M  $\text{BH}_3\cdot\text{THF}$ ,  $\text{TMSOTf}$ ,  $\text{CH}_2\text{Cl}_2$  (89%); **b:**  $\text{PDC}$ ,  $t\text{-BuOH}$ ,  $\text{Ac}_2\text{O}$ ,  $\text{CH}_2\text{Cl}_2$  (70%)

**Scheme 50** Synthesis of D-glucuronic acid glycosyl donor

Thus, an efficient synthetic method has been developed for the preparation of the D-glucuronic acid thioglycoside **40**. This donor is an essential building block for the synthesis of

an orthogonally protected disaccharide, which can provide efficient access to numerous H/HS oligosaccharides.

### 3.4. Conclusion

Dengue virus is one of several flaviviruses that have re-emerged in the last century and has become one of the most important in regard of morbidity. Despite its medical significance, there are currently no therapeutic agents available against DENV. The EGP covers the entire exposed surface of DENV and its DIII region is the major site of host cell surface receptor binding that initiates infection.

Numerous studies have reported inhibition of DENV infection by the glycosaminoglycan (GAG) heparan sulfate (HS). It is assumed that this and other negatively charged carbohydrates may act to aggregate virus particles on the cell surface and therefore facilitate EGP binding to its primary receptor for infection. However, the structure of this primary DENV receptor is still not known.

On the other hand, a recent study of mammalian cell surface glycans involved in DENV infection identified DENV inhibition by the glycolipid Paragloboside, which bears as glycans structure the tetrasaccharide  $\text{Gal}\beta(1-4)\text{GlcNAc}\beta(1-3)\text{Gal}\beta(1-4)\text{Glc}\beta$  (Lacto-*N*-neotetraose,  $\text{nLc}_4$ , LNnT).<sup>110</sup> Further studies have concluded that disaccharide  $\text{Gal}\beta(1-4)\text{GlcNAc}\beta$  (lactosamine) is the minimum unit and  $\beta$ -GlcNAc may be a key determinant for  $\text{nLc}_4$  binding to the surface of DENV-2.

Therefore, we aimed to synthesize a range of  $\text{nLc}_4$ -related glycans as well as a number of HS fragments for biological investigation. In this chapter the synthesis of a  $\text{GlcNAc}\beta(1-3)\text{Gal}\beta(1-4)\text{GlcNAc}$  trisaccharide probe has been discussed. Several approaches have been investigated towards the synthesis of this trisaccharide probe involving various protecting group manipulations. Finally, suitable conditions were established which led to the successful coupling of glycosyl donor **24** and glycosyl acceptor **26**. The protected trisaccharide **23** has been efficiently synthesized, and the desired final compound **18** was obtained in high yields after deprotection (Scheme 51). The unprotected trisaccharide **18** is now under biological investigation.

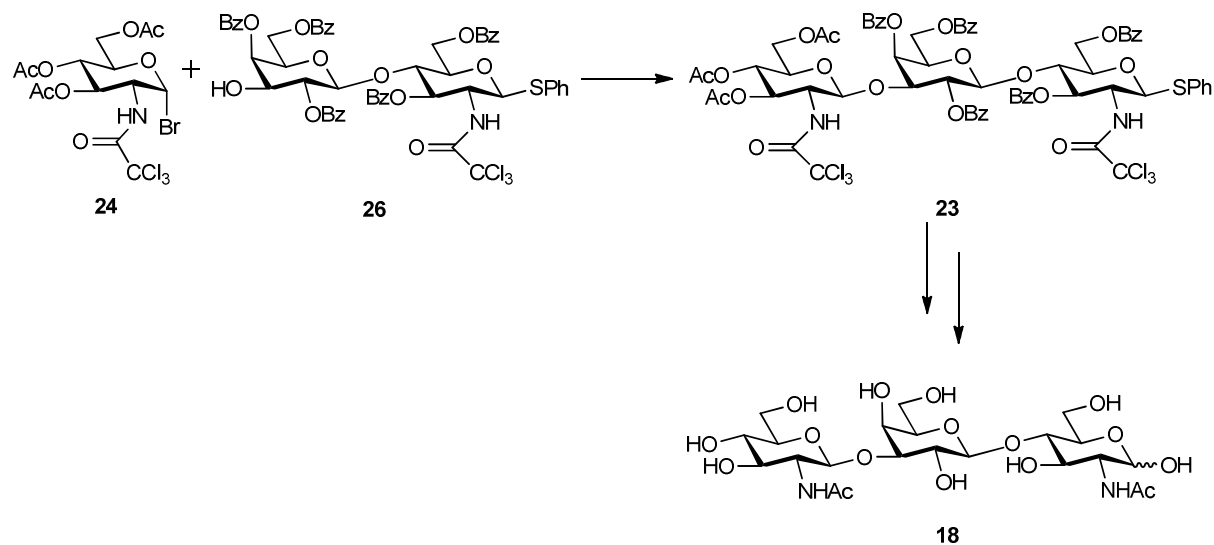

**Scheme 51** Synthesis of GlcNAc $\beta$ (1-3)Gal $\beta$ (1-4)GlcNAc trisaccharide probe

Moreover, the synthesis of D-glucuronic acid thioglycoside **40** has also been performed efficiently to provide a building block for the synthesis of HS oligosaccharides. In fact, **40** can be employed as a donor for the synthesis of an orthogonally protected HS disaccharide, from which multiple target compounds can be synthesized (Scheme 52). Furthermore, the protected disaccharide **42** can also be used as an efficient building block for further HS oligosaccharide syntheses.

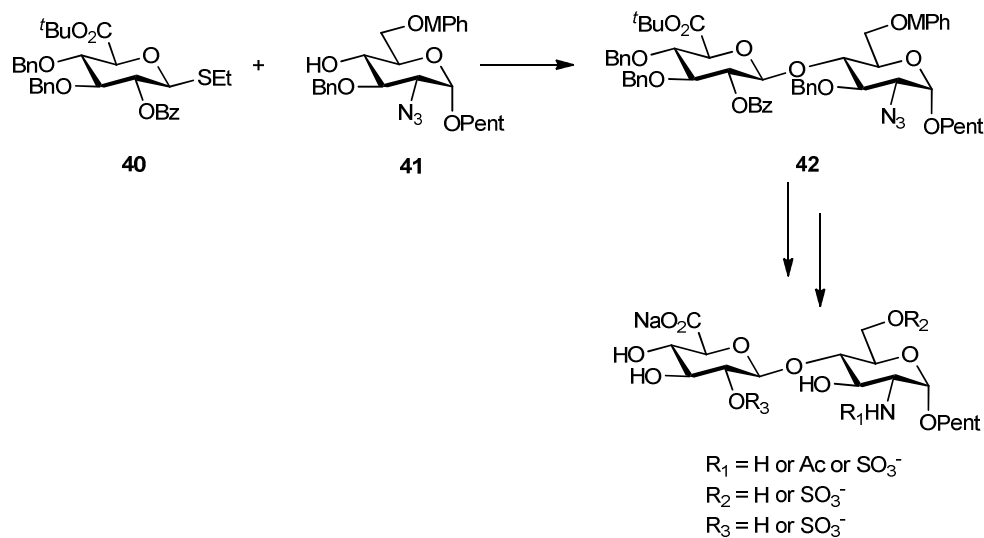

**Scheme 52** Strategy for HS oligosaccharide synthesis

## 4. Glycosylation with unprotected acceptors

### 4.1. Methods for glycosylation with unprotected carbohydrates

In the last two to three decades the biological importance of carbohydrates has been reassessed. In the past these compounds were considered predominantly as energy sources or as main components of cell walls (e.g. cellulose, chitin). Nowadays, it is well-established that carbohydrates and oligosaccharides play important roles in many biological processes such as cellular communication, cell adhesion, recognition of bacteria and viruses, often in the form of their glycoconjugates (glycoproteins, proteoglycans, glycolipids).<sup>158-160</sup> Typically, the binding motifs for these specific interactions (also called epitopes or antigens) is not the full complex glycoconjugate, but a smaller oligosaccharide unit or sub-unit.<sup>161-164</sup> For example, as it was outlined in Chapter 3.1.2, inhibition of mammalian host cell infection by the dengue virus was mediated by the tetrasaccharide Lacto-*N*-neotetraose (nLc<sub>4</sub>), which is the glycan sub-structure of the glycolipid Paragloboside.<sup>110</sup>

Studying and understanding these biological interactions require access to complex carbohydrates such as oligosaccharides. Isolation of complex saccharides from natural sources is often difficult to be achieved in sufficient quantity and purity for biological investigation. In many cases enzymatic syntheses cannot be applied due to the same reasons and its limitations for certain glycosidic linkages. Therefore, the most comprehensive method is the chemical synthesis of oligosaccharide fragments. However, as it was pointed out in Chapter 3.1.3, due to the wide diversity and complexity of carbohydrates, chemical synthesis of oligosaccharides is challenging and it cannot be automated like oligopeptide and -nucleotide synthesis. The multifunctional monosaccharide units often need selective protection via several chemical steps, and next, conditions of glycosylation need to be tuned to the specific glycosyl donor and glycosyl acceptor, where an effective promoter needs to be identified to activate the donor to react efficiently with the acceptor. Thus, typically many protecting group manipulations are required on both the glycosyl donor and the acceptor to achieve a regio- and stereoselective glycosylation.

So far little research has been done to develop glycosylation methods with unprotected glycosyl donors or/and acceptors. Unprotected trichloroacetimidate donors have been reported



for glycosylation of primary alcohols including the OH-6 in hexoses.<sup>165</sup> In fact, the unprotected trichloroacetimidate could not even be prepared, instead it formed the more stable 1,2-orthoamide, which could be used as a glycosyl donor activated with TMSOTf (Scheme 53).

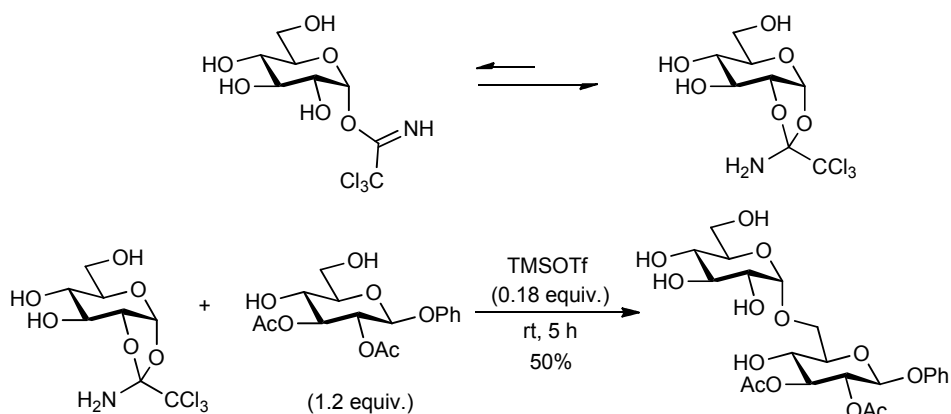

**Scheme 53** Glycosylation with unprotected glycosyl imidate

Furthermore, it is known that stannylene-activation of a hydroxyl group increases the nucleophilicity of the oxygen atom to react with various electrophiles, and therefore tin-mediated regioselective acylation,<sup>166</sup> alkylation<sup>166</sup> as well as glycosylation<sup>167,168</sup> have been investigated. The tin species lead to selective activation and glycosylation at the O-6 position of the unprotected methyl galacto- and glucopyranosides,<sup>167</sup> while the methyl  $\alpha$ -L-rhamnopyranoside gives selective reaction at the O-3 position.<sup>168</sup> This result can be explained by the reaction of tin with the *cis*-vicinal glycol systems to form stannylene acetals. Therefore, the transformation can be performed selectively at the stannylene-activated position (Scheme 54).

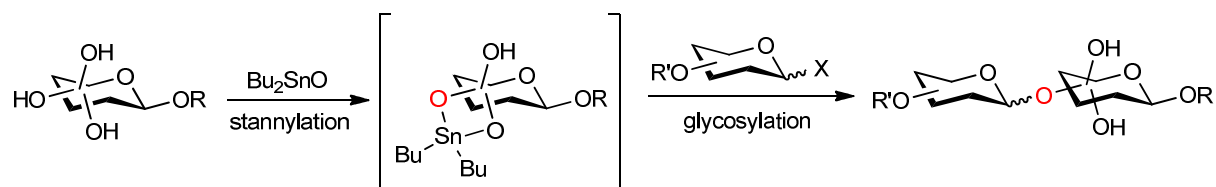

**Scheme 54** Stannylene activation method in glycosylation

Interestingly, using the stannylene activation method a regioselective shift from  $\beta$ -(1 $\rightarrow$ 6) to  $\beta$ -(1 $\rightarrow$ 3)-glycosylation of non-protected methyl  $\beta$ -D-galactopyranoside was achieved by the addition of  $\text{Bu}_4\text{NF}$ .<sup>169</sup> This observation can presumably be explained by generation of the pentacoordinated tin-complex by the means of the fluoride ion. This resulting complex has a greater nucleophilicity than the original stannylene acetal and reacts preferably with the glycosyl donor to afford the  $\beta$ -(1 $\rightarrow$ 3)-disaccharide (Scheme 55).

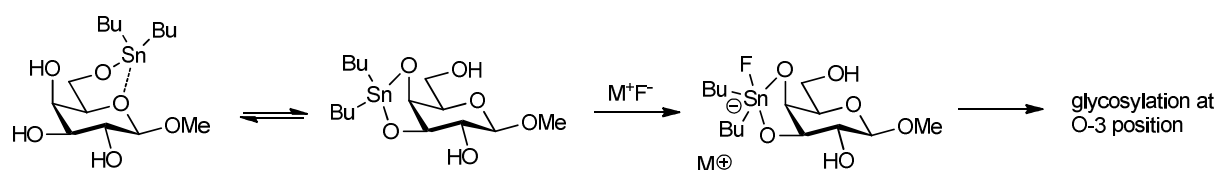

**Scheme 55** Proposed mechanism of the  $\text{Bu}_2\text{SnO}/\text{F}^-$  ion-mediated glycosylation

Notably, the stannylene mediated method generally requires an additional synthetic step to install the activating stannylene group. Furthermore, the use of stoichiometric quantities of toxic and lipophilic organotin species constitutes a limitation.

On the other hand, the use of arylboronic acids is an alternative procedure that does not work by activating, but by masking the corresponding hydroxyl groups.<sup>170</sup> Boronic acid derivatives can form easily cyclic boronates from *cis*-1,2-diol moieties as well as 4,6-position in carbohydrates. In this way, they can function as a temporary protecting group and the glycosyl donor can attack the most reactive free hydroxyl group giving rise to a regioselective glycosylation (Scheme 56).<sup>171</sup>

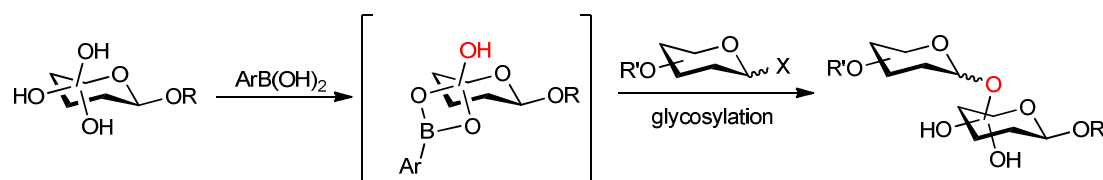

**Scheme 56** Boronate masking method for regioselective glycosylation

In addition, a diarylboronic acid-derived catalyst has recently been reported to be capable of regioselective activation of glycosyl acceptors.<sup>172</sup> It was demonstrated that a

diphenylborinic acid derivative can catalyze regioselective acylation<sup>173</sup> and alkylation<sup>174</sup> of carbohydrate derivatives as well as regioselective glycosylation of unprotected glycosyl acceptors.<sup>172</sup> Mechanistic studies suggested that the borinate ester serves as a precatalyst, from which the ethanolamine ligand is displaced under the reaction conditions. In contrast to the boronic acid derivatives, which mask *cis*-hydroxyl groups, the borinic acid catalyst activates *cis*-diol groups toward electrophilic attack (Scheme 57).

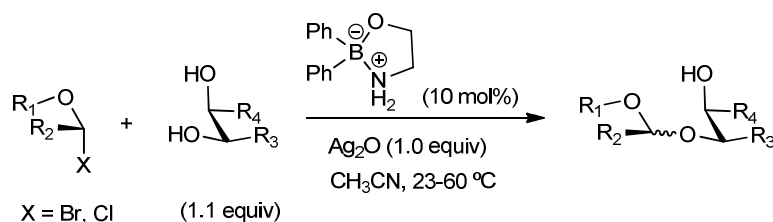

**Scheme 57** Borinic acid-catalyzed regioselective glycosylation

Most recently, an alternative methodology has been reported by Thiem and Matwiejuk.<sup>175</sup> Oxyanions obtained from partially protected acceptors were glycosylated by employing glycosyl halides without the use of a promoter (Scheme 58). Besides the high regioselectivity, stereospecific glycosidic bond formation was also achieved even in the absence of the participating group at C-2. However, it should be noted, that the scope of the method needs to be extended to different glycosyl acceptors since only methyl  $\alpha$ -D-glucopyranoside derivatives have been employed so far.

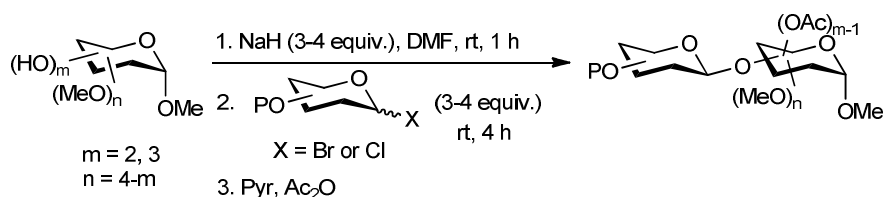

**Scheme 58** Regioselective glycosylation employing saccharide oxyanions

Obviously, these results are highly interesting and it is evident that this area is underdeveloped and new methods, as well as more systematic studies are necessary to facilitate glycosylations with unprotected carbohydrates.

## 4.2. Aim of the project

Regioselective glycosylation represents a key challenge for oligosaccharide synthesis, since an acceptor bears multiple hydroxyl groups, which can undergo glycosylation. The problem of regioselectivity has generally been addressed through the use of protecting groups to suppress glycosylation at undesired positions. Thus, additional operations are required to install and remove a number of protecting groups. In certain cases, inherent differences in the steric and/or electronic properties of the hydroxyl groups may be exploited to achieve selective glycosylation.

Some organometallic compounds are known to coordinate to *cis*-diols and therefore these can either activate specific OH groups or act as a temporary masking group. In particular, organotin and diarylboronic acid derivatives can activate certain hydroxyl groups of the acceptor monosaccharides and in this way direct selective glycosylations to take place. On the other hand, phenylboronic acid derivatives act in a different way and serve as an *in situ* generated acetal type protecting group.

Nevertheless, the procedures known until now are generally optimized on a case-by-case basis, and the regiochemical outcome may depend on the structure of the glycosyl donor. Therefore, we wished to study the regioselective glycosylation more thoroughly by the means of organoboron derivatives and find a more general method that can be applied to target-oriented synthesis.

## 4.3. Results and discussion

### 4.3.1. Investigating the use of diphenylborinic acid as a catalyst

This project has been started recently in Robert Madsen's group with the aim to develop new and efficient procedures for coupling of unprotected monosaccharides. Couplings can be performed either by employing unprotected glycosyl donors or with unprotected glycosyl acceptors. Glycosylation with unprotected glycosyl donors can be restricted due to the instability of some unprotected donors (e.g. glycosyl halides). In addition, the hydroxyl groups of the donor have similar reactivity to the hydroxyl groups of the acceptor leading to the self-condensation of the donor. Therefore, glycosylation with unprotected acceptors may result in a more successful strategy, even though it presents also a number of challenges:

- The glycosyl acceptor should be soluble in organic solvents
- The glycosyl donor should react regioselectively only with one of the hydroxyl groups of the acceptor
- Preferrably, the glycosylation reaction should be efficient for a variety of glycosyl acceptors
- The formation of the glycosidic linkage should be reasonably stereoselective

Regioselective glycosylation with an unprotected acceptor can be achieved either by selective activation or by selective deactivation of one of the hydroxyl groups.

Borinic acid catalyzed regioselective acylation of carbohydrates was reported by Mark Taylor *et al.* at the beginning of 2011.<sup>173</sup> It was identified that the commercially available and inexpensive diphenyl borinic acid acts as a pre-catalyst and can activate *cis*-1,2-diol groups toward electrophilic attack. The broad scope demonstrated that this method enables selective acylation of the secondary hydroxyl groups of a wide range of monosaccharide substrates. Furthermore, regioselective alkylation of carbohydrate derivatives has also been performed using the same borinic acid precatalyst.<sup>174</sup> Therefore, it raised the question whether this organoboron derivative can also catalyze glycosylation reactions in a regioselective way.

In this context it occurred of high interest to study the ability of the diphenyl borinic acid to promote regioselective Koenigs-Knorr glycosylations. Glycosyl bromide derivatives

were selected as donors and unprotected thioglycosides as acceptors. In this way, the coupled disaccharides could be used as donors for a further glycosylation reaction.

To avoid incidental acetyl migration the stable and crystalline 2,3,4,6-tetra-*O*-benzoyl- $\alpha$ -D-glucopyranosyl bromide (**50**) was chosen as a standard glycosyl donor, which was prepared efficiently in 2 steps (Scheme 59).

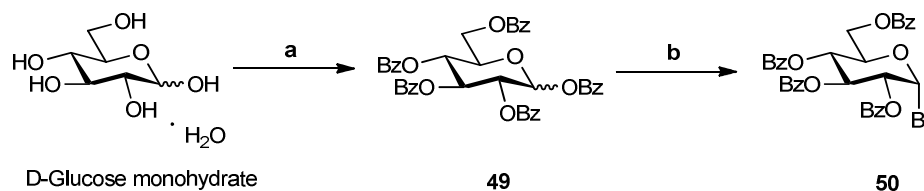

**a:** *BzCl*, pyridine (95%); **b:** 33% *HBr* in *AcOH*, *CH<sub>2</sub>Cl<sub>2</sub>* (89%)

**Scheme 59** Synthesis of 2,3,4,6-tetra-*O*-benzoyl- $\alpha$ -D-glucopyranosyl bromide

Even though it is known that acceptors with unprotected primary hydroxyl groups are only poorly soluble in the organic solvents mostly used for glycosylation reactions (e.g. acetonitrile, DCM, THF etc), we did not wish to introduce additional protecting groups. Thus, in the first experiment unprotected galactose thioglycoside **51** was coupled with the donor **50** in presence of 10 mol% of diphenyl borinic acid in acetonitrile, using silver triflate ( $\text{AgOTf}$ ) as a promoter (Table 13, entry 1). However, the reaction led to the formation of a mixture of three compounds, which were not isolated. Changing the solvent to  $\text{CH}_2\text{Cl}_2/\text{DMF}$  (4:1) or nitromethane did not improve the efficiency of the reaction significantly (Table 13, entries 2 and 3).

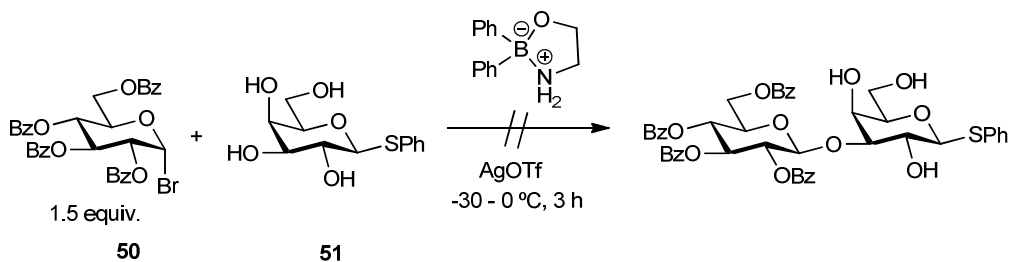
**Table 13** Diphenyl borinic acid catalyzed glycosylation with phenyl 1-thio- $\beta$ -D-galactopyranoside

Entry	Solvent	Product
1	CH <sub>3</sub> CN	3 products
2	CH <sub>2</sub> Cl <sub>2</sub> /DMF (4 :1)	-
3	CH <sub>3</sub> NO <sub>2</sub>	-

These results could be explained considering the poor solubility of the acceptor that gives rise to a highly diluted reaction mixture disabling the donor to react with the coupling partner. To avoid this problem the more soluble unprotected 6-deoxy sugar derivatives were introduced. The silver triflate promoted coupling reaction between **50** and methyl  $\alpha$ -L-rhamnopyranoside (**52**) in the presence of the organoboron catalyst in CH<sub>2</sub>Cl<sub>2</sub>/CH<sub>3</sub>CN (4:1) delivered the  $\beta$ (1 $\rightarrow$ 3)-linked disaccharide **53** in 42 % yield (Table 14, entry 1). Interestingly, in the absence of the catalyst the same product was formed in 33% yield (Table 14, entry 2). Notably, the glycosylation was much slower in CH<sub>3</sub>CN and the disaccharide was obtained only in 19% yield after 24 hours (Table 14, entry 3). This indicates that dichloromethane accelerates the glycosylation reaction, and therefore, we decided to apply the mixture of CH<sub>2</sub>Cl<sub>2</sub>/CH<sub>3</sub>CN as a solvent for further investigations. It should be noted that the structure of the product was elucidated by means of NMR, which indicated the  $\beta$ -glycosidic linkage with the  $J_{1',2'} = 7.8$  Hz coupling constant. Based on HSQC spectra the peak of C-3 was significantly shifted down-field, which clearly confirms the (1 $\rightarrow$ 3)-bond formation.

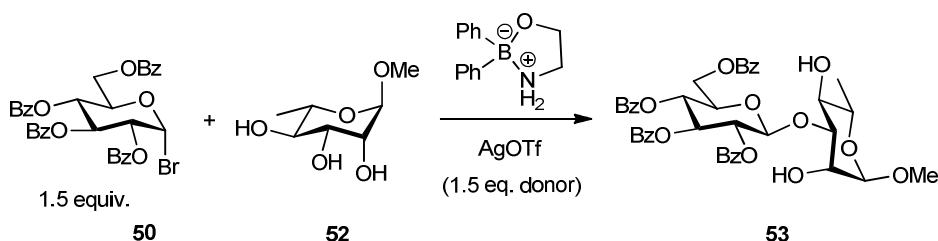

**Table 14** Diphenyl borinic acid catalyzed glycosylation with methyl  $\alpha$ -L-rhamnoside

Entry	Solvent	Borinic acid	Temp [°C]	Time [h]	Yield [%]
1	DCM/MeCN (4:1)	10 mol%	-30	3	42
2	DCM/MeCN (4:1)	—	-30	3	33
3	MeCN	10 mol%	-30-rt	24	19

Under the same reaction conditions as in Table 14, entry 1 the glycosylation reaction with the unprotected fucose derivative **54** resulted in the desired  $\beta$ (1 $\rightarrow$ 3) disaccharide **55** in 46% yield. Notably, significant hydrolysis of the donor followed by benzoyl group migration from the O-2 to the O-1 position of **56** was also observed (Scheme 60).

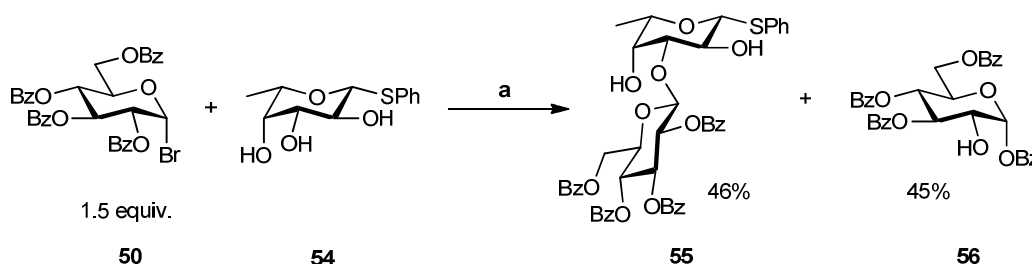

**a:** 10 mol% 2-Aminoethyl diphenylborinate, AgOTf,  $\text{CH}_2\text{Cl}_2 / \text{CH}_3\text{CN}$  (4:1), -30 °C (46%)

**Scheme 60** Diphenyl borinic acid catalyzed glycosylation with phenyl 1-thio- $\beta$ -L-fucoside

These aforementioned results did not convince us whether the diphenylborinic acid can actually promote the regioselective glycosylation or the products observed are actually formed due to the steric and/or electronic properties of the hydroxyl groups. It should be noted that the moderate yields can be explained by the high degree of donor hydrolysis. To avoid this we decided to introduce the glycosyl acetate **31** as a donor for the glycosylation under different conditions. Surprisingly, the coupling reaction between the unprotected rhamnose derivative **52** and **31** promoted by  $\text{BF}_3 \cdot \text{Et}_2\text{O}$  in the presence of 10 mol% borinic acid catalyst afforded the unexpected trisaccharide **57** in 34% yield (Scheme 61, eq. 1).

In addition, the same coupling was obtained by the use of peracetylated  $\beta$ -D-glucose derivative (Scheme 61, eq. 2).

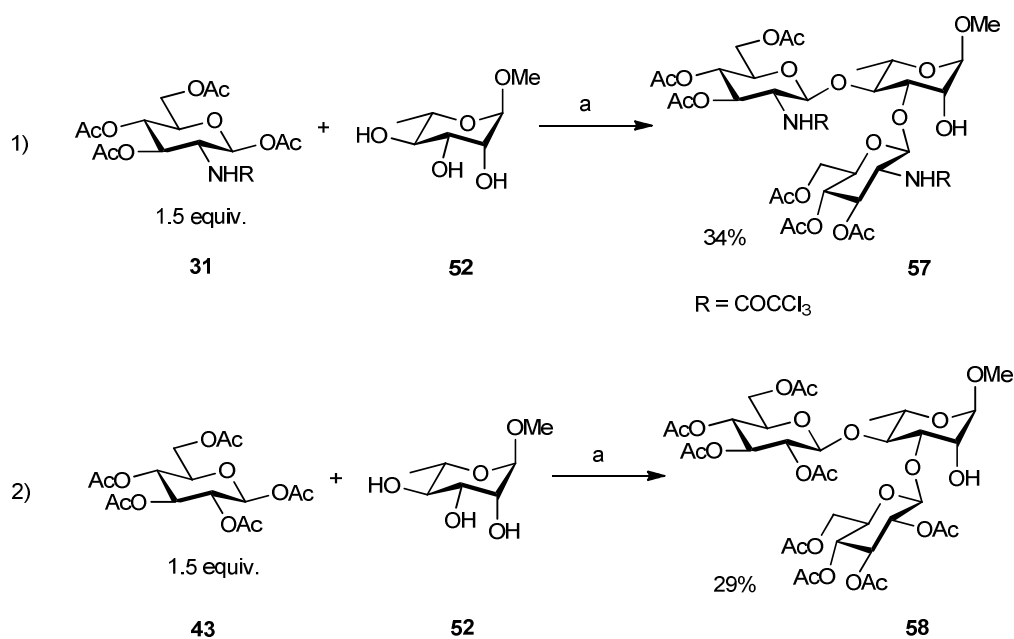

**a:** 10 mol% 2-Aminoethyl diphenylborinate,  $\text{BF}_3 \cdot \text{Et}_2\text{O}$ ,  $\text{CH}_2\text{Cl}_2 / \text{CH}_3\text{CN}$  (4:1)

**Scheme 61** Diphenyl borinic acid catalyzed glycosylation of glycosyl acetates

These results may indicate that the diphenylborinic acid does not affect a regioselective glycosylation. Presumably, due to sterical hindrance the glycosyl donor **50** could not afford the corresponding trisaccharide but in fact, the glycosylation reactions gave the same result without active participation of the catalyst. However, in contrast to our results, most recently and during the course of this work Mark Taylor's group reported that the diphenylborinic acid can catalyze Koenigs-Knorr glycosylation reactions (as illustrated in Chapter 4.1, Scheme 57).<sup>172</sup> In fact, glycosyl halides were activated by  $\text{Ag}_2\text{O}$  and coupled with a number of glycosyl acceptors efficiently with high yield and with high regioselectivity (see Scheme 57).

#### 4.3.2. Investigating the use of phenylboronic acid as a masking group

After studying the influence of the diphenylborinic acid catalyst in glycosylation reactions we sought to test the possibility to form glycosyl borate esters and use them for regioselective glycosylations.

Although the phenylboronic esters of glycosides are usually prepared by azeotropic distillation in the presence of benzene or toluene to remove the generated water,<sup>176</sup> we wished to apply a one-pot method to prepare the cyclic boronate followed by glycosylation.

In fact, the formation of the boronic esters is reversible and the equilibrium can be shifted by removing the generated water from the reaction mixture. Thus, the glycosyl acceptor **54** was first reacted with phenylboronic acid in CH<sub>2</sub>Cl<sub>2</sub> at room temperature in the presence of 4 Å molecular sieves, followed by the addition of the glycosyl donor **50** promoted by Ag<sub>2</sub>O. After 30 hours 27% of β(1→2)-linked disaccharide **59** and 54% of the unreacted donor **50** were isolated. Complete conversion could not be achieved by applying more promoter or extending the reaction time (Table 15, entry 1). Presumably, the insoluble Ag<sub>2</sub>O is not reactive enough to activate the stable benzoylated glycosyl bromide. Thus, the soluble and more reactive AgOTf was introduced which afforded complete conversion of the donor in 3 hours. However, 57% of the donor hydrolyzed and the desired disaccharide **59** was isolated in only 35% yield (Table 15, entry 2). The low yields can be explained by the hydrolysis of the glycosyl bromide, which could not be avoided even by thorough attention to dry reaction conditions (solvent, reagents, inert atmosphere).

**Table 15** Phenyl boronate mediated glycosylation with phenyl 1-thio-β-L-fucoside

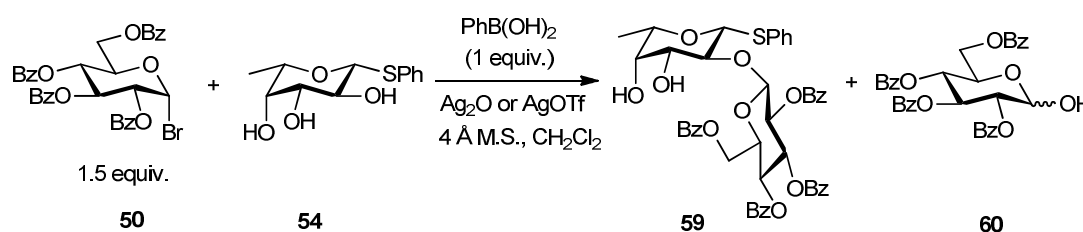

Entry	Promoter <sup>a</sup>	Solvent	Temp [°C]	Time [h]	Product	Yield [%]
1	Ag <sub>2</sub> O	CH <sub>2</sub> Cl <sub>2</sub>	rt	30	<b>59</b> + <b>50</b>	27 + 54
2	AgOTf	CH <sub>2</sub> Cl <sub>2</sub>	-30-0 °C	3	<b>59</b> + <b>60</b>	35 + 57

<sup>a</sup>1.5 equiv. promoter compared to the donor

To prove the effective role of the phenylboronic acid we decided to study the glycosylation reaction with an acceptor in which the primary hydroxyl group is present and not protected

(Table 16). However, with the unprotected galactose thioglycoside **51** the Ag<sub>2</sub>O promoted glycosylation reaction did not give any coupling product, and only the starting materials were recovered after 30 hours (Table 16, entry 1). Using AgOTf as promoter the expected β(1→3)-disaccharide was isolated in 49% yield (Table 16, entry 2), while the absence of the phenylboronic acid resulted in the mixture of several compounds (Table 16, entry 3). Noteworthy, the stannylene mediated regioselective glycosylation afforded selective glycosylation in good yield. The corresponding tin acetal formation was performed in refluxing methanol, followed by the glycosylation reaction which afforded the β(1→6)-disaccharide exclusively in 75% yield (Table 16, entry 4).

**Table 16** Glycosylation with phenyl 1-thio-β-D-galactoside

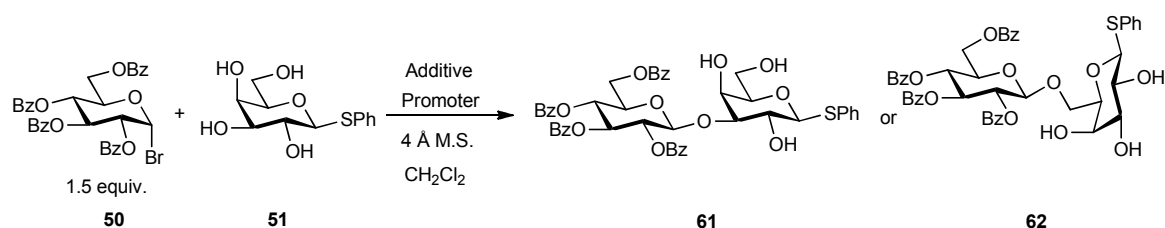

Entry	Promoter <sup>a</sup>	Additive <sup>b</sup>	Temp [°C]	Time [h]	Product	Yield [%]
1	Ag <sub>2</sub> O	PhB(OH) <sub>2</sub>	rt	30	-	-
2	AgOTf	PhB(OH) <sub>2</sub>	-30-0 °C	3	<b>61</b>	49
3	AgOTf	-	-30-0 °C	3	several	-
4 <sup>c</sup>	AgOTf	Bu <sub>2</sub> SnO	-30-0 °C	3	<b>62</b>	75

<sup>a</sup>Promoter (1.5 equiv. donor) <sup>b</sup>Additive (1 equiv. acceptor) <sup>c</sup>(i) 1 equiv. Bu<sub>2</sub>SnO to the acceptor, reflux in MeOH for 3 h, (ii) donor, 4 Å M.S., AgOTf (1.5 equiv. donor), CH<sub>2</sub>Cl<sub>2</sub>, -30-0 °C

It should be noted that all the glycosylation reactions performed in the presence of phenylboronic acid provided one coupling product exclusively. The low yield can derive from the donor hydrolysis, which is presumably promoted by water released during the reaction.

In fact, AgOTf paired with collidine is a useful combination often used to promote Koenigs-Knorr glycosylation reactions,<sup>177</sup> because the pair acts as a base and as proton scavenger and thus may improve the yields. Accordingly, the glycosylation reaction with the fucose thioglycoside **54** employing collidine and AgOTf provided the β(1→2)-linked

disaccharide **59** in good yield (66%) and only trace amounts of the donor was hydrolyzed (Scheme 62, eq. 1). In addition, a similar improvement was observed in the case of the unprotected galactose derivative **51**, which afforded the disaccharide **61** in 74% yield (Scheme 62, eq. 2). Noteworthy, high regioselectivity as well as stereospecific glycosidic bond formation were achieved as can be concluded from the value of the  $J_{1,2'}$  coupling constant (7.8 Hz) and the HSQC, HMBC spectra.

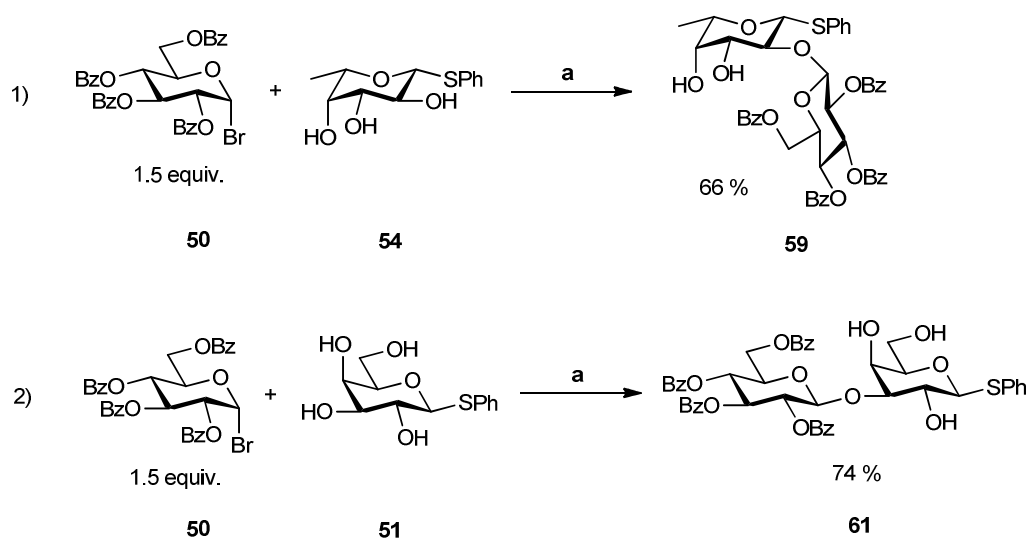

**a:** (i)  $PhB(OH)_2$ , 4 Å M.S.,  $CH_2Cl_2$ ; (ii)  $AgOTf$ , collidine,  $-30-0\text{ }^\circ\text{C}$

**Scheme 62** Regioselective glycosylation in the presence of collidine

Although this method still offers room for optimization, it can be affirmed that the presence of collidine seems to be crucial. Further important parameters for future investigation are variation of the structures of the glycosyl acceptor and donor. Hence, this project will be continued in the Madsen group and may lead to the development of an efficient procedure for regioselective glycosylation with unprotected acceptors.

#### 4.4. Conclusion

The role of organoboron derivatives has been studied for a regioselective Koenigs-Knorr glycosylation. Diphenyl borinic acid has been reported to coordinate to *cis*-vicinal diol moieties and thereby catalyze regioselective alkylation<sup>174</sup> and acylation<sup>173</sup>. Thus, it raised the question whether the borinic acid catalyst could also activate glycosyl acceptors via the formation of tetracoordinated adducts of the *cis*-1,2-diol motifs leading to regioselective glycosylation.

To avoid competing acetyl migration the stable perbenzoylated  $\alpha$ -D-glucopyranosyl bromide has been prepared and used as a glycosyl donor for all the experiments. Due to the poor solubility of the unprotected acceptors with primary hydroxyl group the 6-deoxy hexopyranosides have been employed. Diphenylborinic acid catalyzed glycosylation with methyl  $\alpha$ -L-rhamnoside as well as with phenyl 1-thio- $\beta$ -D-fucoside afforded one coupled disaccharide in moderate yield. However, the same result was also observed in the absence of the catalyst. Interestingly, the glycosylation reaction of a glycosyl acetate promoted by  $\text{BF}_3 \cdot \text{Et}_2\text{O}$  in the presence of the same catalyst afforded an unexpected trisaccharide. These results indicated that diphenyl borinic acid has no influence on the coupling reaction. Very recently borinic acid-catalyzed regioselective Koenigs-Knorr glycosylation has been reported<sup>172</sup>, but time did not allow us to consider or investigate these results in further detail.

On the other hand, arylboronic acids are also known to coordinate to *cis*-diols and in this case act as a masking group.<sup>171</sup> In case of the phenylboronic acid, regioselective glycosylation of the glycosyl bromide **50** promoted by AgOTf has been carried out selectively. Although due to the high degree of hydrolysis of the donor the corresponding disaccharides were isolated in moderate yield. By employing collidine as a base and proton scavenger significant improvement was obtained and resulted in the desired product exclusively and in high yield. This method needs to be optimized and various acceptors and donors have to be studied. In addition, the procedure tolerates the thiophenyl group. Therefore, by applying thioglycosides as acceptors the products can be used for further glycosylation reactions.

By a more thorough investigation of the organoboron mediated glycosylation reaction this ongoing project may provide an efficient method for coupling of unprotected acceptors

and may lead to the development of a new procedure for glycosylation with unprotected carbohydrates.

## 5. Summary

The work described herein has been conducted at the Department of Chemistry, DTU and, during an eight months external stay in Mark von Itzstein's group, at the Institute for Glycomics at the Griffith University in Australia. The thesis is divided into four main chapters (not counting experimental section and appendices) detailing subjects related to organometallic and carbohydrate chemistry. The work on the projects reported in Chapters 1, 2 and 4 was conducted at DTU, while chapter 3 describes the work carried out at the Institute for Glycomics in Australia. The four different topics are not interlinked and can be read independently of each other.

In the first project the rate of addition and protonation for a number of Grignard reagents were studied by means of competition experiments. It has been shown that the rate of carbonyl addition may compare with the rate of protonation for highly reactive Grignard reagents such as allylmagnesium bromide and benzylmagnesium chloride. The obtained results have been published in *Organic & Biomolecular Chemistry*.

The next project has involved the further development of the conditions previously discovered in the Madsen group for the direct coupling of alcohols and amines with dihydrogen liberation. An isolated ruthenium *N*-heterocyclic carbene complex and a metathesis catalyst based system were found to be effective promoters for the amidation and the results have been summarized in a full paper in *Chemistry - A European Journal*. The project has been continued in the group and a more thorough mechanistic investigation has been performed.<sup>178</sup> Furthermore, the well-defined ruthenium complex has been employed for the formation of both imines<sup>179</sup> and esters.<sup>180</sup>

During the external stay a trisaccharide probe as a putative DENV receptor has been efficiently synthesized. The trisaccharide is now under biological investigation and may provide valuable information for a successful structure-based drug design against DENV. In addition, a D-glucuronic acid thioglycoside building block has been prepared successfully for the synthesis of H/HS oligosaccharides, which can also inhibit DENV infection.

In the last project the role of organoboron derivatives has been studied in glycosylation reactions of glycosyl bromides with unprotected acceptors. This project has just been started in the group and the main goal is to develop new procedures for coupling unprotected



monosaccharides by activating and/or blocking certain OH groups. In this way, regioselective glycosylations can take place and a number of protecting group manipulations can be avoided.

## 6. Experimental Section

### 6.1. Grignard addition reactions in the presence of protic agents

#### General experimental methods

All chemicals were obtained from Aldrich. Diethyl ether was distilled from sodium and benzophenone under an argon atmosphere. GC yields were obtained on a Shimadzu GC2010 instrument equipped with an Equity™ 1 column (15 m x 0.10 mm x 0.10 μm) using octane as the internal standard. During the GC-analysis the injector temperature was 250 °C, the GC-program used was the following: 40 °C hold 5 min, 20 °C/min to 250 °C, hold 5 min. <sup>1</sup>H NMR and <sup>13</sup>C NMR spectra of the isolated compounds were recorded on a Varian Mercury 300 spectrometer with residual solvent signals as reference.<sup>181</sup> Chemical shifts are reported as δ values (ppm) and the coupling constants (*J*) are given in Hz.

#### General procedure for the synthesis of the Grignard reagents

The Grignard reagents were prepared under an argon atmosphere by the slow addition (6 hours) of the distilled halide to the magnesium (turnings form) in diethyl ether. Into the Grignard solution 1 mol of octane per mol of Grignard reagent was added as an internal standard.

The concentrations of the Grignard reagents were determined through titration: 1 mL of Grignard was hydrolyzed with water and the hydroxide produced was titrated with 1 M HCl using phenolphthalein as an indicator.

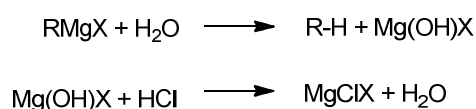

#### General procedure for competition experiments

The competition experiments were carried out in a very simple way. To obtain complete conversion the Grignard reagent was reacted with an excess of carbonyl and protic substrate mixture. The solution of the Grignard reagent (10 mL) and the competing compounds in

diethyl ether (10 mL) were prepared separately in 20 mL disposable syringes. The two syringes were connected with a short polyethylene capillary tube. The Grignard reagent was pressed into the syringe with the substrate solution within 2-3 s. The reaction mixture was washed with saturated ammonium chloride solution, then with water. The organic phase was dried over  $\text{MgSO}_4$  and filtered. The solution was analyzed by quantitative GC and the peaks for the products were measured relative to the peak for octane (internal standard). To obtain complete conversion the Grignard solution was reacted with an excess of the substrates dissolved in dry diethyl ether.

### General procedure for isolated competition experiments

Allyl magnesium bromide in ether (0.1 M, 100 mL) was added slowly to the mixture of the carbonyl compound in ether saturated with water (0.6 M, 100 mL). The mixture was stirred at room temperature for 30 minutes. Then, the mixture was diluted with ether, washed with saturated aq.  $\text{NH}_4\text{Cl}$  solution and water. The organic layer was dried over  $\text{MgSO}_4$ , filtered, and purified by distillation.

### 1-Phenyl-but-3-en-1-ol

Colorless oil

Chemical formula:  $\text{C}_{10}\text{H}_{12}\text{O}$

Molecular weight: 148.20 g/mol

Yield: 73%

$^1\text{H}$  NMR ( $\text{CDCl}_3$ ):  $\delta$  2.50 (m, 2H,  $\text{CH}_2\text{-CH=CH}_2$ ), 3.15 (s, 1H, OH), 4.67 (t, 1H,  $J = 6.6$  Hz,  $\text{CH-OH}$ ), 5.15 (m, 2H,  $\text{CH=CH}_2$ ), 5.79 (m, 1H,  $\text{CH=CH}_2$ ), 7.24-7.38 (m, 5H, aromatic)

$^{13}\text{C}$  NMR ( $\text{CDCl}_3$ ):  $\delta$  43.4 ( $-\text{CH}_2-$ ), 73.1 ( $\text{CH-OH}$ ), 117.7 ( $\text{CH=CH}_2$ ), 125.7, 127.1, 128.0, 143.7 (aromatic), 134.3 ( $\text{CH=CH}_2$ ). NMR data are in accordance with literature values.<sup>182</sup>

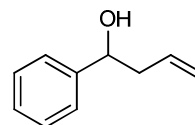

### 1-(4-Methoxyphenyl)but-3-en-1-ol

Colorless oil

Chemical formula:  $\text{C}_{11}\text{H}_{14}\text{O}_2$

Molecular weight: 178.23 g/mol

Yield: 29%

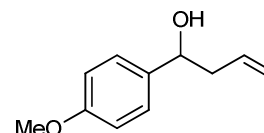

$^1\text{H}$  NMR ( $\text{CDCl}_3$ ):  $\delta$  2.45 (m, 2H,  $\text{CH}_2\text{-CH=CH}_2$ ), 3.19 (s, 1H, OH), 3.74 (s, 3H,  $\text{OCH}_3$ ), 4.61 (t, 1H,  $J = 6.5$  Hz,  $\text{CH-OH}$ ), 5.10 (m, 2H,  $\text{CH=CH}_2$ ), 5.75 (m, 1H,  $\text{CH=CH}_2$ ), 6.77-6.88 (m, 2H, aromatic), 7.19-7.25 (m, 2H, aromatic)

$^{13}\text{C}$  NMR ( $\text{CDCl}_3$ ):  $\delta$  43.3 ( $-\text{CH}_2-$ ), 54.8 ( $\text{OCH}_3$ ), 73.0 ( $\text{CH-OH}$ ), 111.1, 112.6, 129.0, 159.2 (aromatic) 118.0 ( $\text{CH=CH}_2$ ), 134.3, ( $\text{CH=CH}_2$ ). NMR data are in accordance with literature values.<sup>183</sup>

### 1-(3-Hydroxyphenyl)-3-buten-1-ol

Pale yellow oil

Chemical formula:  $\text{C}_{10}\text{H}_{12}\text{O}_2$

Molecular weight: 164.20 g/mol

Yield: 26%

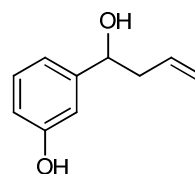

$^1\text{H}$  NMR ( $\text{CD}_3\text{OD}$ ):  $\delta$  2.45 (m, 2H,  $\text{CH}_2\text{-CH=CH}_2$ ), 4.58 (t, 1H,  $J = 6.3$  Hz,  $\text{CH-OH}$ ), 5.02 (m, 2H,  $\text{CH=CH}_2$ ), 5.78 (m, 1H,  $\text{CH=CH}_2$ ), 6.70-6.71 (m, 1H, aromatic), 6.79-6.82 (m, 2H, aromatic), 7.11-7.16 (m, 1H, aromatic)

$^{13}\text{C}$  NMR ( $\text{CD}_3\text{OD}$ ):  $\delta$  44.6 ( $-\text{CH}_2-$ ), 74.8 ( $\text{CH-OH}$ ), 113.8, 115.1, 117.5, 130.3, 147.4, 158.3 (aromatic), 136.1 ( $\text{CH=CH}_2$ ), 118.4 ( $\text{CH=CH}_2$ ). NMR data are in accordance with literature values.<sup>184</sup>

### 4-Phenyl-hepta-1,6-dien-4-ol

Yellow oil

Chemical formula:  $\text{C}_{13}\text{H}_{16}\text{O}$

Molecular weight: 188.27 g/mol

Yield: 21%

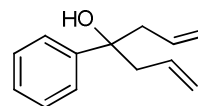

$^1\text{H}$  NMR ( $\text{CDCl}_3$ ):  $\delta$  2.20 (s, 1H, OH), 2.41 (m, 2H,  $\text{CH}_2\text{-CH=CH}_2$ ), 2.56 (m, 2H,  $\text{CH}_2\text{-CH=CH}_2$ ), 4.97 (m, 4H, 2 x  $\text{CH=CH}_2$ ), 5.54 (m, 2H, 2 x  $\text{CH=CH}_2$ ), 7.08-7.29 (m, 5H, aromatic).

$^{13}\text{C}$  NMR ( $\text{CDCl}_3$ ):  $\delta$  43.4, 46.7 (2 x  $-\text{CH}_2-$ ), 75.0 ( $\text{C-OH}$ ), 118.7, 119.1 (2 x  $\text{CH=CH}_2$ ), 125.2, 125.4, 128.0, 128.2, 128.5, 145.6 (aromatic), 133.1, 133.3 (2 x  $\text{CH=CH}_2$ ). NMR data are in accordance with literature values.<sup>185</sup>

### 5-(2'-Propenyl)-7-octen-1,5-diol

Yellow oil

Chemical formula: C<sub>11</sub>H<sub>20</sub>O<sub>2</sub>

Molecular weight: 184.28 g/mol

Yield: 8%

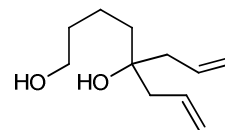

<sup>1</sup>H NMR (CDCl<sub>3</sub>): δ 1.45 (m, 6H, 3 x -CH<sub>2</sub>-), 2.14 (d, 4H, *J* = 7.2 Hz, CH<sub>2</sub>-CH=CH<sub>2</sub>), 2.83 (s, 1H, OH), 3.51 (t, 2H, *J* = 6.0 Hz, CH<sub>2</sub>-OH), 3.82 (s, 1H, OH), 5.02 (m, 4H, 2 x CH=CH<sub>2</sub>), 5.78 (m, 2H, 2 x CH=CH<sub>2</sub>) CH<sub>2</sub>-CH=CH<sub>2</sub>)

<sup>13</sup>C NMR (CDCl<sub>3</sub>): δ 19.5 (C-CH<sub>2</sub>-), 32.9, 38.7 (2 x -CH<sub>2</sub>-) 43.7 (CH<sub>2</sub>-CH=CH<sub>2</sub>), 62.1 (CH<sub>2</sub>-OH), 73.8 (C-OH), 118.4 (CH=CH<sub>2</sub>), 134.1 (CH=CH<sub>2</sub>). NMR data are in accordance with literature values.<sup>186</sup>

## 6.2. Ruthenium catalyzed synthesis of amides from primary alcohols and amines

### General experimental methods

All chemicals were obtained from Aldrich and used without further purification, except for PCyp<sub>3</sub>·HBF<sub>4</sub> (prepared according to a known procedure<sup>69</sup>). Toluene was distilled from sodium and benzophenone under a nitrogen atmosphere. Column chromatography separations were carried out on silica gel (220-440 mesh). <sup>1</sup>H NMR and <sup>13</sup>C NMR spectra were recorded on a Varian Mercury 300 spectrometer with residual solvent signals as reference.<sup>181</sup> Chemical shifts are reported as δ values (ppm) and the coupling constants (*J*) are given in Hz. IR spectra were obtained on a Bruker alpha-P spectrometer. Mass spectrometry was performed by direct inlet on a Shimadzu GCMS-QP5000 instrument. GC yields were obtained on a Shimadzu GC2010 instrument equipped with an Equity™ 1 column (15 m x 0.10 mm x 0.10 μm) using dodecane as the internal standard. During the GC-analysis the injector temperature was 300 °C, the GC-program used was the following: 50 °C hold 2 min, 40 °C/min to 300 °C, hold 5 min. Optical rotation was measured on a Perkin-Elmer 241 polarimeter. Microanalyses were obtained at the Microanalytical Laboratory, University of Vienna while high resolution mass spectra were recorded at the Department of Physics and Chemistry, University of Southern Denmark.

### Preparation of RuCl<sub>2</sub>(*p*-cymene)I<sup>*i*</sup>Pr (**8**)

1,3-Diisopropylimidazolium chloride (124.1 mg, 0.77 mmol) and Ag<sub>2</sub>O (75.3 mg, 0.33 mmol) were suspended in dry, degassed CH<sub>2</sub>Cl<sub>2</sub> (7 mL) under argon and refluxed for 1 h in a Schlenk flask with a reflux condenser. [Ru(*p*-cymene)Cl<sub>2</sub>]<sub>2</sub> (201.0 mg, 0.33 mmol) in anhydrous, degassed CH<sub>2</sub>Cl<sub>2</sub> (3 mL) was then added and the solution was refluxed for 2 h and concentrated *in vacuo*.

The residue was purified on a short silica gel column (CH<sub>2</sub>Cl<sub>2</sub>/*i*PrOH 9:1) to give **8** (96%) as a red-orange solid.

IR (neat): 3152, 3099, 3077, 2958, 2930, 2870, 1473, 1412, 1391, 1369, 1297, 1265, 1213, 1133, 856, 770, 700 cm<sup>-1</sup>.

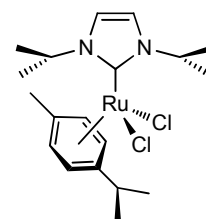

$^1\text{H}$  NMR (300 MHz,  $\text{CDCl}_3$ ):  $\delta$  1.30 (d, 12H,  $J = 6.9$  Hz,  $^i\text{Pr CH}(\text{CH}_3)_2$ ), 1.42 (d, 3H,  $J = 6.6$  Hz,  $p$ -cymene  $\text{CH}(\text{CH}_3)_2$ ), 1.54 (d, 3H,  $J = 6.6$  Hz,  $p$ -cymene  $\text{CH}(\text{CH}_3)_2$ ), 2.07 (s, 3H,  $p$ -cymene  $\text{CH}_3$ ), 2.92 (m, 1H,  $p$ -cymene  $\text{CH}(\text{CH}_3)_2$ ), 4.91 (m, 1H, NCHN), 5.14 (d,  $J = 6.0$  Hz, 2H), 5.29 (m, 2H), 5.47 (d,  $J = 6.0$  Hz, 2H), 7.09 (s, 2H).  $^1\text{NMR}$  data are in accordance with literature values.<sup>65</sup>

$^{13}\text{C}$  NMR (75 MHz,  $\text{CDCl}_3$ ):  $\delta$  18.6, 22.7, 23.1, 25.0, 30.8, 52.0, 83.1, 85.2, 97.2, 106.4, 118.9, 171.2. MS  $[\text{M}-\text{Cl}]^+$ : calcd 423.11, found 423.07. Anal. Calcd for  $\text{C}_{19}\text{H}_{30}\text{Cl}_2\text{N}_2\text{Ru}$ : C, 49.78; H, 6.60; N, 6.11. Found: C, 49.84; H, 6.44; N, 6.05.

### Preparation of 1,3-dicyclohexylimidazolium chloride

1,4 Diazadiene: Glyoxal (5.47 mL of 40 % aqueous solution, 48 mmol) was gradually mixed with a solution of cyclohexylamine (11 mL, 96 mmol) in  $\text{CH}_2\text{Cl}_2$  (15 mL). Anhydrous  $\text{CaCl}_2$  (4.44 g, 4 mmol) was added to this solution with stirring and cooling (ice bath).

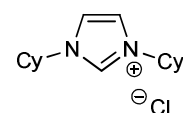

After 30 min, the mixture was warmed close to boiling and an organic layer was separated by decantation. The layer was concentrated *in vacuo*.

The desired diaziene was used in the next step without any purification.

Acetyl chloride (3.75 mL, 53 mmol) was added with stirring and cooling below 15 °C to a solution of  $\text{CH}_2(\text{NMe})_2$  (7.5 mL, 53 mmol) in  $\text{CH}_2\text{Cl}_2$  (25 mL). A white suspension of a salt was formed. The solution of the corresponding diazadiene in  $\text{CH}_2\text{Cl}_2$  (20 mL) was added in one portion to this suspension. The cooling bath was removed and after a spontaneous exothermal stage (ca. 15 min) the solution was evaporated *in vacuo* at 75 °C leaving an oily mixture. The residue was crystallized from  $\text{CH}_2\text{Cl}_2$  and EtOAc after cooling to 10 °C. The crystals were separated and washed with cold EtOAc and  $\text{Et}_2\text{O}$ .

$^1\text{H}$  NMR ( $\text{CDCl}_3$ ):  $\delta$  1.15-2.32 (m, 20H, 4.52 (tt, 2H,  $J = 3.9$  Hz, 11.9 Hz), 7.37 (s, 1H), 7.38 (s, 1H), 10.88 (s, 1H).

$^{13}\text{C}$  NMR ( $\text{CDCl}_3$ ):  $\delta$  24.5, 24.8, 33.5, 59.7, 119.3, 136.1.

### Preparation of $\text{RuCl}_2(p\text{-cymene})\text{ICy}$ (9) and $\text{RuI}_2(p\text{-cymene})\text{ICy}$ (10)

1,3-Dicyclohexylimidazolium chloride (56 mg, 0.21 mmol) and  $\text{Ag}_2\text{O}$  (25 mg, 0.11 mmol) were suspended in dry, degassed  $\text{CH}_2\text{Cl}_2$  (5 mL) under argon and refluxed for 1.5 h in a

Schlenk flask with a reflux condenser.  $[\text{Ru}(p\text{-cymene})\text{I}_2]_2$  (101 mg, 0.10 mmol) in anhydrous, degassed  $\text{CH}_2\text{Cl}_2$  (1 mL) was then added and the solution was refluxed for 45 min and concentrated *in vacuo*. The residue was purified by preparative TLC ( $\text{CH}_2\text{Cl}_2/\text{acetone}$  9:1) to give 48 mg (43%) of complex **9** and 70.8 mg of complex **10** (49%).

For **9**:

IR (neat): 3091, 2957, 2921, 2848, 1466, 1455, 1446, 1418, 1380, 1290, 1276, 1232, 1190, 897, 747, 697  $\text{cm}^{-1}$ .

$^1\text{H}$  NMR (300 MHz,  $\text{CDCl}_3$ ):  $\delta$  1.14-2.44 (m, 20H, cyclohexyl), 1.36 (d, 6H,  $J = 6.9$  Hz,  $\text{CH}(\text{CH}_3)_2$ ), 2.13 (s, 3H, *p*-cymene  $\text{CH}_3$ ), 2.84 (m, 1H), 4.84 (m, 2H), 5.14 (d, 2H,  $J = 6.0$  Hz), 5.46 (d, 2H,  $J = 6.0$  Hz), 7.04 (s, 2H).

$^{13}\text{C}$  NMR (50 MHz,  $\text{CDCl}_3$ ):  $\delta$  18.8, 23.1, 25.3, 25.4, 26.0, 31.2, 35.4, 35.8, 59.3, 83.6, 85.3, 97.3, 105.1, 119.3, 171.4.  $^1\text{H}$  NMR data are in accordance with literature values.<sup>67</sup>

MS  $[\text{M}-\text{Cl}]^+$ : calcd 503.18, found 503.15. Anal. Calcd for  $\text{C}_{25}\text{H}_{38}\text{Cl}_2\text{N}_2\text{Ru}$ : C, 55.75; H, 7.11; N, 5.20. Found: C, 55.14; H, 6.84; N, 5.16.

For **10**:

IR (neat): 2924, 2853, 1439, 1371 1284, 1224, 1189, 995, 908, 725  $\text{cm}^{-1}$ .

$^1\text{H}$  NMR ( $\text{CDCl}_3$ ):  $\delta$  1.20-2.46 (m, 20H, cyclohexyl), 1.35 (d, 6H,  $J = 6.9$  Hz,  $\text{CH}(\text{CH}_3)_2$ ), 1.97 (s, 3H, *p*-cymene  $\text{CH}_3$ ), 3.31 (m, 1H), 5.03 (d,  $J = 5.9$  Hz, 2H), 5.14 (m, 2H), 5.80 (d,  $J = 5.9$  Hz, 2H), 7.10 (s, 2H).

$^{13}\text{C}$  NMR ( $\text{CDCl}_3$ ):  $\delta$  20.0, 23.4, 24.7, 25.3, 26.1, 31.4, 35.3, 35.8, 61.8, 80.5, 88.1, 100.4, 107.3, 119.9, 167.7. Anal. Calcd for  $\text{C}_{25}\text{H}_{38}\text{I}_2\text{N}_2\text{Ru}$ : C, 42.41; H, 5.51; N, 3.73. Found: C, 42.50; H, 5.67; N, 3.78.

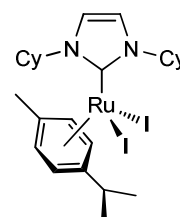
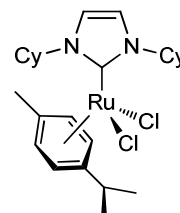

### General procedure for amidation with complex **8** (catalyst A)

$\text{RuCl}_2(p\text{-cymene})\text{I}^t\text{Pr}$  (**8**) (11.5 mg, 0.025 mmol),  $\text{PCy}_3$  (7.0 mg, 0.025 mmol) and  $\text{KO}^t\text{Bu}$  (5.6 mg, 0.05 mmol) were placed in an oven-dried Schlenk tube. Vacuum was applied and the tube was then filled with argon (repeated twice). Freshly distilled toluene (1 mL) was added and the mixture was heated to reflux under an argon atmosphere for 20 min. The alcohol (0.5 mmol) and the amine (0.5 mmol) were added and the mixture was heated to reflux under an



argon atmosphere for 24 hours. After cooling to room temperature the solvent was removed *in vacuo* and the residue was purified by column chromatography to give the corresponding amide.

### General procedure for amidation with metathesis catalyst (catalyst B)

Hoveyda-Grubbs 1<sup>st</sup> generation catalyst (15 mg, 0.025 mmol), 1,3-diisopropylimidazolium chloride (4.7 mg, 0.025 mmol) and KO<sup>t</sup>Bu (8.4 mg, 0.075 mmol) were placed in an oven-dried Schlenk tube. Vacuum was applied and the tube was then filled with argon (repeated twice). Freshly distilled toluene (1 mL) was added and the mixture was heated to reflux under an argon atmosphere for 20 min. The alcohol (0.5 mmol) and the amine (0.5 mmol) were added and the mixture was heated to reflux under an argon atmosphere for 24 hours and then worked up as described above.

### *N*-Benzyl-2-phenylacetamide

White solid

Chemical formula: C<sub>15</sub>H<sub>15</sub>NO

Molecular weight: 225.29 g/mol

Melting point: 118-119 °C

Literature melting point<sup>187</sup>: 118-119 °C

IR (KBr): 3288, 3063, 3030, 1637, 1551, 1454, 1431, 1029, 693, 602 cm<sup>-1</sup>.

<sup>1</sup>H NMR (CDCl<sub>3</sub>): δ 7.38-7.15 (m, 10H, aromatic), 5.88 (bs, 1H, CONH), 4.40 (d, 2H, *J* = 5.8 Hz, NHCH<sub>2</sub>Ph), 3.61 (s, 2H, PhCH<sub>2</sub>C(O)).

<sup>13</sup>C NMR (CDCl<sub>3</sub>): δ 171.0 (C=O), 138.2, 134.9, 129.5, 129.1, 128.7, 127.6, 127.5, 127.5 (aromatic), 43.9, 43.6 (2 × -CH<sub>2</sub>-). NMR data are in accordance with literature values.<sup>188</sup>

MS: *m/z* 226 [M+H].

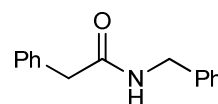

### *N*-Hexyl-2-phenylacetamide

White solid

Chemical formula: C<sub>14</sub>H<sub>21</sub>NO

Molecular weight: 219.32 g/mol

Melting point: 55-57 °C

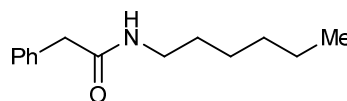

Literature melting point<sup>189</sup>: 53-54 °C

IR (KBr): 3254, 3066, 2937, 1628, 1552, 1477, 1156, 692, 544 cm<sup>-1</sup>.

<sup>1</sup>H NMR (CDCl<sub>3</sub>): δ 7.33-7.18 (m, 5H, aromatic), 6.13 (bs, 1H, -CONH-), 3.48 (s, 2H, Ph-CH<sub>2</sub>-N), 3.18-3.09 (m, 2H, NH-CH<sub>2</sub>-CH<sub>2</sub>), 1.38 (p, 2H, *J* = 7.0 Hz, N-CH<sub>2</sub>-CH<sub>2</sub>-), 1.26-1.13 (m, 6H, 3 × -CH<sub>2</sub>-), 0.82 (t, 1H, *J* = 6.7 Hz, CH<sub>3</sub>).

<sup>13</sup>C NMR (CDCl<sub>3</sub>): δ 171.0 (C=O), 135.3, 129.2, 128.7, 127.0 (aromatic), 43.6 (PhCH<sub>2</sub>NH), 39.6 (N-CH<sub>2</sub>-CH<sub>2</sub>-), 31.3, 29.3, 26.4, 22.4 (4 × -CH<sub>2</sub>-), 13.9 (CH<sub>3</sub>). NMR data are in accordance with literature values.<sup>190</sup>

MS: *m/z* 219 [M].

### ***N*-Benzylundecanamide**

White solid

Chemical formula: C<sub>18</sub>H<sub>29</sub>NO

Molecular weight: 275.43 g/mol

Melting point: 84-86 °C (recryst. from heptane)

IR (neat): 3298, 3064, 2916, 2848, 1638, 1550, 1454, 1225, 695 cm<sup>-1</sup>.

<sup>1</sup>H NMR (CDCl<sub>3</sub>): δ 7.23-7.16 (m, 5 H, aromatic), 6.01 (bs, 1H, C(O)NH), 4.32 (d, 2H, *J* = 5.7 Hz, -NH-CH<sub>2</sub>-Ph), 2.10 (t, 2H, *J* = 7.4 Hz, CH<sub>2</sub>-C=O), 1.55 (p, 2H, *J* = 7.3 Hz, -CH<sub>2</sub>-CH<sub>2</sub>-C=O), 1.26-1.14 (m, 14 H, 7 × -CH<sub>2</sub>-), 0.80 (t, 3H, *J* = 6.6 Hz, CH<sub>3</sub>).

<sup>13</sup>C NMR (CDCl<sub>3</sub>): δ 173.4 (C=O), 138.7, 128.9, 128.0, 127.6 (aromatic), 43.7 (NHCH<sub>2</sub>Ph), 37.0 (CH<sub>2</sub>C(O)), 32.1 (-CH<sub>2</sub>-), 29.8 (-CH<sub>2</sub>-), 29.7 (-CH<sub>2</sub>-), 29.6 (-CH<sub>2</sub>-), 29.5 (-CH<sub>2</sub>-), 26.0 (-CH<sub>2</sub>-), 22.9 (-CH<sub>2</sub>-CH<sub>3</sub>), 14.4 (CH<sub>3</sub>).

MS: *m/z* 275 [M].

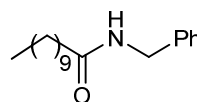

### ***N*-Benzylbenzamide**

White solid

Chemical formula: C<sub>14</sub>H<sub>13</sub>NO

Molecular weight: 211.26 g/mol

Melting point: 98-100 °C (recryst. from H<sub>2</sub>O/EtOH)

Literature melting point<sup>191</sup>: 104 °C

IR (neat): 3322, 1642, 1543, 1418, 1313, 1260, 728, 693 cm<sup>-1</sup>.

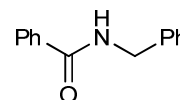

$^1\text{H}$  NMR ( $\text{CDCl}_3$ ):  $\delta$  7.82-7.77 (m, 2H, aromatic), 7.55-7.25 (m, 8H, aromatic), 6.54 (bs, 1H, C(O)NH), 4.64 (d, 2H,  $J = 5.7$  Hz,  $\text{NCH}_2\text{Ph}$ ).

$^{13}\text{C}$  NMR ( $\text{CDCl}_3$ ):  $\delta$  167.5 (C=O), 138.3, 134.5, 131.7, 128.9, 128.7, 128.0, 127.7, 127.1, (aromatic), 44.2 ( $\text{NHCH}_2\text{Ph}$ ). NMR data in accordance with literature values.<sup>191</sup>

MS:  $m/z$  211 [M].

### ***N*-Benzyl-2-(4-chlorophenyl)acetamide**

Colorless crystals

Chemical formula:  $\text{C}_{15}\text{H}_{14}\text{ClNO}$

Molecular weight: 259.73 g/mol

Melting point: 151-153 °C

Literature melting point<sup>192</sup>: 155-156 °C

IR (neat/solid): 3277, 3026, 2917, 1642, 1539, 1491, 1246, 690  $\text{cm}^{-1}$ .

$^1\text{H}$  NMR ( $\text{DMSO}-d_6$ ):  $\delta$  8.58 (t, 1H,  $J = 5.7$  Hz, C(O)NH), 7.39-7.20 (m, 9H, aromatic), 4.27 (d, 2H,  $J = 5.9$  Hz,  $\text{NHCH}_2\text{Ph}$ ), 3.49 (s, 2H, Ar- $\text{CH}_2$ -CO).

$^{13}\text{C}$  NMR ( $\text{DMSO}-d_6$ ):  $\delta$  169.7 (C=O), 139.3, 135.3, 131.0, 130.8, 128.2, 128.1, 127.2, 126.7 (aromatic), 42.2, 41.4 (2  $\times$   $-\text{CH}_2-$ ).  $^1\text{H}$  NMR data are in accordance with literature values.<sup>192</sup>

MS:  $m/z$  259 [M].

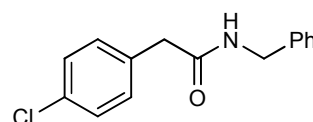

### ***N*-Benzyl-2-(4-bromophenyl)acetamide**

White solid

Chemical formula:  $\text{C}_{15}\text{H}_{14}\text{BrNO}$

Molecular weight: 304.18 g/mol

$^1\text{H}$  NMR ( $\text{CDCl}_3$ ):  $\delta$  3.56 (s, 2H,  $\text{PhCH}_2$ ), 4.42 (d, 2H,  $J = 5.8$  Hz,  $\text{CH}_2\text{NH}$ ), 5.67 (bs, 1H, NH), 7.50-7.13 (m, 9H, aromatic).

$^{13}\text{C}$  NMR ( $\text{CDCl}_3$ ):  $\delta$  50.4 and 54.0 (2  $\times$   $\text{PhCH}_2$ ), 120.0, 127.1, 128.2, 128.5, 130.6, 131.6, 139.1, 140.2 (aromatic), 171.9 (C=O).

MS:  $m/z$  303 [M].

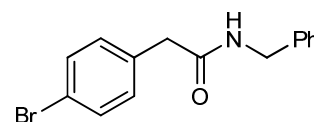

### ***N*-Benzyl-2-(4-nitrophenyl)acetamide**

Red solid

Chemical formula: C<sub>15</sub>H<sub>14</sub>N<sub>2</sub>O<sub>3</sub>

Molecular weight: 270.28 g/mol

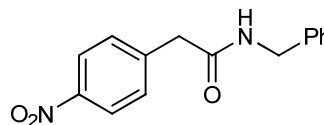

<sup>1</sup>H NMR (CDCl<sub>3</sub>): δ 8.19 (d, 2H, *J* = 8.6 Hz, aromatic), 7.46 (d, 2H, *J* = 8.8 Hz, aromatic), 7.36-7.20 (m, 5H, aromatic), 5.89 (bs, 1H, NH), 4.43 (d, 2H, *J* = 5.7 Hz, CH<sub>2</sub>NH), 3.67 (s, 2H, PhCH<sub>2</sub>C=O).

<sup>13</sup>C NMR (CDCl<sub>3</sub>): δ 159.0 (C=O), 137.8, 130.3, 128.9, 127.9, 127.8, 124.1 (aromatic), 44.1, 43.4 (2 x PhCH<sub>2</sub>).

MS: *m/z* 270 [M].

### ***N*-Benzylhexanamide**

Colorless crystals

Chemical formula: C<sub>13</sub>H<sub>19</sub>NO

Molecular weight: 205.3 g/mol

Melting point: 50-52 °C (recryst. from pentane)

Literature melting point<sup>193</sup>: 52-53.5 °C.

IR (CHCl<sub>3</sub>): 3291, 3085, 2957, 2928, 1639, 1552, 1454, 697 cm<sup>-1</sup>.

<sup>1</sup>H NMR (CDCl<sub>3</sub>): δ 7.37-7.25 (m, 5H, aromatic), 5.69 (bs, 1H, CON-H), 4.45 (d, 2H, *J* = 5.7 Hz, N-CH<sub>2</sub>-Ph), 2.21 (t, 2H, *J* = 7.4 Hz, CH<sub>2</sub>-C=O), 1.66 (p, 2H, *J* = 7.5 Hz, CH<sub>2</sub>-CH<sub>2</sub>-C=O), 1.37-1.24 (m, 4H, CH<sub>3</sub>-CH<sub>2</sub>-CH<sub>2</sub>-), 0.89 (t, 3H, *J* = 6.8 Hz, CH<sub>3</sub>-).

<sup>13</sup>C NMR (CDCl<sub>3</sub>): δ 173.2 (C=O), 138.5, 128.8, 127.9, 127.6 (aromatic), 43.6 (NCH<sub>2</sub>Ph), 36.9 (CH<sub>2</sub>-C=O), 31.6 (-CH<sub>2</sub>-), 25.6 (-CH<sub>2</sub>-), 22.5 (CH<sub>2</sub>-CH<sub>3</sub>), 14.1 (CH<sub>3</sub>).

MS: *m/z* 205 [M].

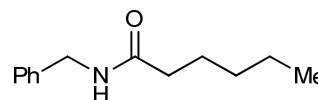

### ***N*-Benzyl-2-(benzylamino)acetamide**

Clear oil

Chemical formula: C<sub>16</sub>H<sub>18</sub>N<sub>2</sub>O

Molecular weight: 254.33 g/mol

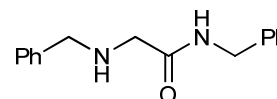

IR (neat): 3319, 3029, 1654, 1522, 1453, 1261, 1029, 737, 699 cm<sup>-1</sup>.

$^1\text{H}$  NMR ( $\text{CDCl}_3$ ):  $\delta$  7.53 (bs, 1H, C(O)NH), 7.40-7.20 (m, 10H, aromatic), 4.47 (d, 2H,  $J = 6.0$  Hz,  $\text{PhCH}_2\text{NC(=O)}$ ), 3.76 (s, 2H,  $\text{Ph-CH}_2\text{-NH}$ ), 3.36 (s, 2H,  $\text{Ph-CH}_2\text{-NH-CH}_2$ ), 1.80 (bs, 1H,  $\text{CH}_2\text{-NH-CH}_2$ ).

$^{13}\text{C}$  NMR ( $\text{CDCl}_3$ ):  $\delta$  171.5 (C=O), 139.4, 138.5, 128.8, 128.7, 128.2, 127.8, 127.6, 127.5 (aromatic), 54.1, 52.1 ( $2 \times -\text{CH}_2-$ ), 43.1 ( $\text{Ph-CH}_2\text{-NC(=O)}$ ).

MS:  $m/z$  255 [M+H].

### 2-Phenyl-*N*-((*R*)-1-phenylethyl)acetamide

Chemical formula:  $\text{C}_{16}\text{H}_{17}\text{NO}$

Molecular weight: 239.31 g/mol

Melting point: 115-116 °C (recryst. from  $\text{H}_2\text{O}/\text{EtOH}$ )

Literature melting point<sup>194</sup>: 117-118 °C.

Optical rotation:  $[\alpha]_{\text{D}} +3.4$  ( $c = 1.0$ ,  $\text{CHCl}_3$ )

Lit. optical rotation<sup>195</sup>:  $[\alpha]_{\text{D}} +3.3$  ( $c = 1.0$ ,  $\text{CHCl}_3$ )

IR (KBr): 3307, 3063, 3028, 2974, 1649, 1541, 1494, 1445, 1356, 1246, 1208, 761, 697  $\text{cm}^{-1}$ .

$^1\text{H}$  NMR ( $\text{CDCl}_3$ ):  $\delta$  7.39-7.61 (m, 10H, aromatic), 5.72 (d, 1H,  $J = 7.1$  Hz, C(O)NH), 5.12 (p, 1H,  $J = 7.0$  Hz,  $\text{PhCH(Me)NH}$ ), 3.57 (s, 2H,  $\text{Ph-CH}_2-$ ), 1.40 (d, 3H,  $J = 6.9$  Hz,  $\text{CH}_3$ ).

$^{13}\text{C}$  NMR ( $\text{CDCl}_3$ ):  $\delta$  170.1 (C=O), 143.2, 135.0, 129.5, 129.1, 128.7, 127.4, 127.4, 126.0 (aromatic), 48.8 ( $\text{PhCH(Me)NH}$ ), 44.0 ( $\text{Ph-CH}_2-$ ), 21.9 ( $\text{CH}_3$ ).

MS:  $m/z$  239 [M].

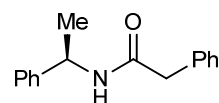

### *N,N'*-Dibenzyl-L-prolinamide

Clear oil

Chemical formula:  $\text{C}_{19}\text{H}_{22}\text{N}_2\text{O}$

Molecular weight: 294.39 g/mol

Optical rotation:  $[\alpha]_{\text{D}} -48.2$  ( $c = 1.0$ ,  $\text{CHCl}_3$ ).

Ref. optical rotation<sup>196</sup>:  $[\alpha]_{\text{D}} -46.3$  ( $c = 1.0$ ,  $\text{CHCl}_3$ ).

IR (neat): 3346, 3061, 2968, 2806, 1670, 1514, 1454, 1028, 748, 700  $\text{cm}^{-1}$ .

$^1\text{H}$  NMR ( $\text{CDCl}_3$ ):  $\delta$  7.74 (bs, 1H, -CONH-), 7.22-7.37 (m, 8H, aromatic), 7.17-7.11 (m, 2H, aromatic), 4.41 (d, 2H,  $J = 5.7$  Hz,  $\text{Ph-CH}_2\text{-NC(O)}$ ), 3.85 (d, 1H,  $J = 12.8$  Hz,  $\text{Ph-CH}_a\text{H}_b\text{-N}$ ), 3.48 (d, 1H,  $J = 12.8$  Hz,  $\text{Ph-CH}_a\text{H}_b\text{-N}$ ), 3.29 (dd, 1H,  $J = 4.9$  Hz,  $J = 10.2$  Hz, H-2), 3.00

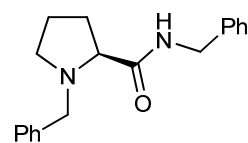

(ddd, 1H,  $J = 2.2$  Hz,  $J = 6.6$  Hz,  $J = 8.9$  Hz, H-5a), 2.20-2.41 (m, 2H, H-3a, H-5b), 1.95 (ddd, 1H,  $J = 4.0$  Hz,  $J = 8.2$  Hz,  $J = 13.0$  Hz, H-3b), 1.84-1.61 (m, 2H, H-4a, H-4b).

$^{13}\text{C}$  NMR ( $\text{CDCl}_3$ ):  $\delta$  174.5 (C=O), 138.5, 138.5, 128.7, 128.7, 128.4, 127.6, 127.4, 127.3 (aromatic), 67.3 (C-2), 60.0, 53.9 (C-5, Ph-CH<sub>2</sub>-NH), 42.9 (Ph-CH<sub>2</sub>-NC(O)), 30.7 (C-3), 24.2 (C-4). NMR data are in accordance with literature values.<sup>197</sup>

MS:  $m/z$  295 [M+H].

## 2-Pyrrolidinone

Colorless crystals

Chemical formula: C<sub>4</sub>H<sub>7</sub>NO

Molecular weight: 85.1 g/mol

Melting point: 26-27 °C

Literature melting point<sup>198</sup>: 25 °C

IR (neat): 3247, 3198, 2921, 2867, 1679, 1462, 1283, 419 cm<sup>-1</sup>.

$^1\text{H}$  NMR ( $\text{CDCl}_3$ ):  $\delta$  6.50 (bs, 1H, C(O)NH), 3.39 (t, 2H,  $J = 7.0$  Hz, NH-CH<sub>2</sub>-CH<sub>2</sub>-), 2.35-2.25 (m, 2H, C(O)-CH<sub>2</sub>-CH<sub>2</sub>-), 2.20-2.05 (m, 2H, NH-CH<sub>2</sub>-CH<sub>2</sub>-).

$^{13}\text{C}$  NMR ( $\text{CDCl}_3$ ):  $\delta$  179.3 (C=O), 42.4 (NH-CH<sub>2</sub>-CH<sub>2</sub>-), 30.1 (CO-CH<sub>2</sub>-CH<sub>2</sub>-), 20.9 (NH-CH<sub>2</sub>-CH<sub>2</sub>-).

MS:  $m/z$  85 [M].

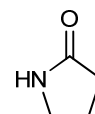

## $\epsilon$ -Caprolactam

Colorless crystals

Chemical formula: C<sub>6</sub>H<sub>11</sub>NO

Molecular weight: 113.16 g/mol

Melting point: 66-68 °C (recryst. from heptane)

Literature melting point<sup>199</sup>: 70-71 °C

IR (neat): 3294, 3197, 2927, 1651, 1416, 1197, 802, 504 cm<sup>-1</sup>.

$^1\text{H}$  NMR ( $\text{CDCl}_3$ ):  $\delta$  7.58 (bs, 1H, C(O)NH), 3.00 (q, 2H,  $J = 5.8$  Hz, NH-CH<sub>2</sub>-CH<sub>2</sub>-), 2.27-2.23 (m, 2H, CO-CH<sub>2</sub>-CH<sub>2</sub>-), 1.59-1.40 (m, 6H, 3 × -CH<sub>2</sub>-).

$^{13}\text{C}$  NMR ( $\text{CDCl}_3$ ):  $\delta$  179.8 (C=O), 42.7 (NH-CH<sub>2</sub>-CH<sub>2</sub>-), 36.9 (C(O)-CH<sub>2</sub>-CH<sub>2</sub>-), 30.7 (-CH<sub>2</sub>-), 29.8 (-CH<sub>2</sub>-), 23.3 (-CH<sub>2</sub>-).

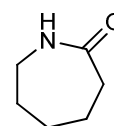

MS:  $m/z$  113 [M].

### ***N*,2-Diphenylacetamide**

Colorless crystals

Chemical formula: C<sub>14</sub>H<sub>13</sub>NO

Molecular weight: 211.26 g/mol

Melting point: 114-115 °C (recryst. from heptane)

Literature melting point<sup>200</sup>: 115-116 °C.

IR (CHCl<sub>3</sub>): 3286, 3257, 3060, 1655, 1599, 1547, 1495, 1442, 1166, 751, 723, 692 cm<sup>-1</sup>.

<sup>1</sup>H NMR (CDCl<sub>3</sub>): δ 7.46-7.20 (m, 10H, aromatic, C(O)NH), 7.12-7.05 (m, 1H, aromatic), 3.73 (s, 2H, PhCH<sub>2</sub>C(O)).

<sup>13</sup>C NMR (CDCl<sub>3</sub>): δ 169.3 (C=O), 137.7, 134.5, 129.6, 129.3, 129.0, 127.8, 124.6, 119.9 (aromatic), 44.9 (PhCH<sub>2</sub>C=O). NMR data in accordance with literature values.<sup>201</sup>

MS:  $m/z$  211 [M].

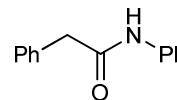

### ***N*-Benzyl-*N*-methyl-2-phenylacetamide**

Yellow oil

Chemical formula: C<sub>16</sub>H<sub>17</sub>NO

Molecular weight: 239.31 g/mol

1:1.4 mixture of rotamers. Major rotamer:

IR (CHCl<sub>3</sub>): 3061, 3029, 1644, 1495, 1453, 1399, 1111, 731, 697 cm<sup>-1</sup>.

<sup>1</sup>H NMR (CDCl<sub>3</sub>): δ 7.39-7.20 (m, 9H, aromatic), 7.12-7.09 (m, 1H, aromatic), 4.61 (s, 2H, NCH<sub>2</sub>Ph), 3.78 (s, 2H, PhCH<sub>2</sub>C(O)), 2.89 (s, 3H, NCH<sub>3</sub>).

<sup>13</sup>C NMR (CDCl<sub>3</sub>): δ 171.2 (C=O), 137.4, 135.0, 128.9, 128.8, 128.6, 128.1, 126.9, 126.4 (aromatic), 51.0 (NCH<sub>2</sub>Ph), 41.3 (PhCH<sub>2</sub>C(O)), 35.3 (NCH<sub>3</sub>).

Minor rotamer:

<sup>1</sup>H NMR (CDCl<sub>3</sub>): δ 7.39-7.20 (m, 9H, aromatic), 7.09-7.07 (m, 1H, aromatic), 4.52 (s, 2H, NCH<sub>2</sub>Ph), 3.75 (s, 2H, PhCH<sub>2</sub>C(O)), 2.95 (s, 3H, NCH<sub>3</sub>).

<sup>13</sup>C NMR (CDCl<sub>3</sub>): δ 171.6 (C=O), 136.5, 135.2, 129.0, 128.9, 128.8, 127.7, 127.4, 126.9 (aromatic), 53.7 (NCH<sub>2</sub>Ph), 41.0 (PhCH<sub>2</sub>C(O)), 34.1 (NCH<sub>3</sub>). NMR data for both rotamers are in accordance with literature values.<sup>53</sup>

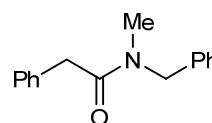

MS:  $m/z$  239 [M].

### ***N*-Hexyl-*p*-methylbenzamide**

Yellow oil

Chemical formula: C<sub>14</sub>H<sub>21</sub>NO

Molecular weight: 219.32 g/mol

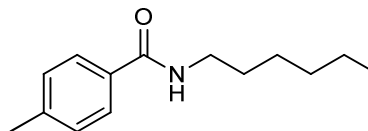

<sup>1</sup>H NMR (CDCl<sub>3</sub>): δ 7.60 (bd, 2H,  $J$  = 8.2 Hz, aromatic), 7.14 (bd, 2H,  $J$  = 8.1 Hz, aromatic), 6.26 (bs, 1H, C(O)NH), 3.33 (q, 2H,  $J$  = 6.4 Hz, NH-CH<sub>2</sub>-CH<sub>2</sub>), 2.30 (s, 3H, CH<sub>3</sub>Ph), 1.51 (p, 2H,  $J$  = 7.0 Hz, NH-CH<sub>2</sub>-CH<sub>2</sub>-), 1.32-1.22 (m, 6H, 3 × -CH<sub>2</sub>-), 0.81 (t, 1H,  $J$  = 6.6 Hz, CH<sub>2</sub>-CH<sub>3</sub>).

<sup>13</sup>C NMR (CDCl<sub>3</sub>): δ 167.4 (C=O), 141.5, 131.9, 129.1, 126.8 (aromatic), 40.0 (NH-CH<sub>2</sub>-CH<sub>2</sub>) 31.5, 29.6, 26.6, 22.5, 21.3, (4 × -CH<sub>2</sub>-, CH<sub>3</sub>Ph), 14.0 (CH<sub>3</sub>). NMR data are in accordance with literature values.<sup>202</sup>

MS:  $m/z$  219 [M].

### ***N*-Hexylbenzamide**

Colorless solid

Chemical formula: C<sub>13</sub>H<sub>19</sub>NO

Molecular weight: 205.3 g/mol

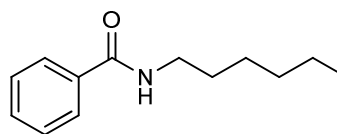

<sup>1</sup>H NMR (CDCl<sub>3</sub>): δ 7.66-7.20 (m, 5H, aromatic), 6.68 (bs, 1H, CONH), 3.27 (q, 2H,  $J$  = 6.5 Hz, NHCH<sub>2</sub>CH<sub>2</sub>), 1.45 (p, 2H,  $J$  = 7.0 Hz, NCH<sub>2</sub>CH<sub>2</sub>), 1.26-1.10 (m, 6H, 3 × CH<sub>2</sub>), 0.76 (t, 3H,  $J$  = 6.3 Hz, CH<sub>3</sub>).

<sup>13</sup>C NMR (CDCl<sub>3</sub>): δ 167.5 (C=O), 134.6, 131.0, 128.3, 126.8 (aromatic), 40.0 (NCH<sub>2</sub>), 31.4, 29.4, 26.5, 22.4 (4 × -CH<sub>2</sub>-), 13.9 (CH<sub>3</sub>). NMR data are in accordance with literature values.<sup>203</sup>

MS:  $m/z$  205 [M].

### **(*E*)-1,10-Dihydroxy-5-decene**

Hoveyda–Grubbs 1<sup>st</sup> generation catalyst (15 mg, 0.025 mmol) was weighted into a Schlenk-flask. Vacuum was applied and the flask was filled with argon. Then toluene (1 mL) was added and followed by the addition of 5-hexen-1-ol (60 μL, 0.5 mmol) and 3,3-dimethyl-1-



butene (258  $\mu\text{L}$ , 2 mmol). The mixture was stirred for 24 hours at 40  $^{\circ}\text{C}$ . The mixture was concentrated *in vacuo* and the residue purified by column chromatography.

Colorless oil

Chemical formula:  $\text{C}_{10}\text{H}_{20}\text{O}_2$

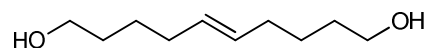

Molecular weight: 172.26 g/mol

Yield: 47%

$^1\text{H}$  NMR ( $\text{CDCl}_3$ ):  $\delta$  1.41 (m, 4H, 2 x  $-\text{CH}_2-$ ), 1.62 (m, 4H, 2 x  $-\text{CH}_2-$ ), 2.04 (m, 4 H, 2 x  $\text{CH}_2-\text{CH}=\text{CH}$ ), 2.34 (s, 2H, 2 x OH), 3.62 (m, 4H, 2 x  $\text{CH}_2-\text{OH}$ ), 5.40 (m, 2H,  $\text{CH}=\text{CH}$ ).

$^{13}\text{C}$  NMR ( $\text{CDCl}_3$ ):  $\delta$  25.6 (2 x  $-\text{CH}_2-\text{CH}_2-\text{CH}_2-$ ), 32.1 (2 x  $-\text{CH}_2-\text{CH}_2-\text{OH}$ ), 32.2 (2 x  $\text{CH}_2-\text{CH}=\text{CH}$ ), 62.8 (2 x  $\text{CH}_2-\text{OH}$ ), 130.3 ( $\text{CH}=\text{CH}$ ). NMR data are in accordance with literature values.<sup>204</sup>

### 6-Cyclohexyl-5-hexen-1-ol

Hoveyda–Grubbs 1<sup>st</sup> generation catalyst (15 mg, 0.025 mmol) was weighted into a Schlenk-flask. Vacuum was applied and the flask was filled with argon. Then toluene (1 mL) was added and followed by the addition of 5-hexen-1-ol (60  $\mu\text{L}$ , 0.5 mmol) and vinylcyclohexane (68  $\mu\text{L}$ , 0.5 mmol). The mixture was stirred for 24 hours at 40  $^{\circ}\text{C}$ . The mixture was concentrated *in vacuo* and the residue was purified by column chromatography.

Colorless oil

Chemical formula:  $\text{C}_{12}\text{H}_{22}\text{O}$

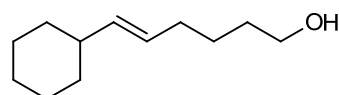

Molecular weight: 469.74 g/mol

Yield: 85 %

$^1\text{H}$  NMR ( $\text{CDCl}_3$ ):  $\delta$  1.04-1.98 (m, 17H, 8 x  $-\text{CH}_2-$ ,  $-\text{CH}-\text{CH}=\text{CH}$ ), 2.23 (s, 1H, OH), 3.61 (m, 2H,  $\text{CH}_2-\text{OH}$ ), 5.34 (m, 2H,  $\text{CH}=\text{CH}$ ).

$^{13}\text{C}$  NMR ( $\text{CDCl}_3$ ):  $\delta$  25.6 ( $-\text{CH}_2-$ ), 26.0 (2 x  $-\text{CH}_2-$ ), 26.2 ( $-\text{CH}_2-$ ), 32.1 ( $-\text{CH}_2-$ ), 32.3 ( $-\text{CH}_2-$ ), 33.2 (2 x  $-\text{CH}_2-$ ), 40.6 ( $-\text{CH}-\text{CH}=\text{CH}$ ), 62.8 ( $\text{CH}_2-\text{OH}$ ), 127.1( $\text{CH}_2-\text{CH}=\text{CH}$ ), 136.8 ( $\text{CH}-\text{CH}=\text{CH}$ ). NMR data are in accordance with literature values.<sup>205</sup>

### N-Benzyl-6-cyclohexylhexanamide

Grubbs 3<sup>rd</sup> generation catalyst (19.8 mg, 0.025 mmol) was weighted into a Schlenk-flask. Vacuum was applied and the flask was filled with argon. Then toluene (1 mL) was added and

followed by the addition of 5-hexen-1-ol (60  $\mu$ L, 0.5 mmol) and vinylcyclohexane (68  $\mu$ L, 0.5 mmol). The mixture was stirred for 24 hours at 40  $^{\circ}$ C. Then benzylamine (55  $\mu$ L, 0.5 mmol) and KO<sup>t</sup>Bu (8.4 mg, 0.075 mmol) were added and the reaction mixture was stirred at reflux for 24 hours. After cooling to room temperature the solvent was removed *in vacuo* and the residue was purified by column chromatography.

White solid

Chemical formula: C<sub>19</sub>H<sub>29</sub>NO

Molecular weight: 287.44 g/mol

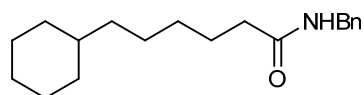

Yield: 33%

<sup>1</sup>H NMR (CDCl<sub>3</sub>):  $\delta$  1.09-1.87 (m, 19H, 9 x -CH<sub>2</sub>-, -CH-CH=CH), 2.19 (m, 2H, CH<sub>2</sub>C(O)), 4.76 (s, 2H, CH<sub>2</sub>Ph), 6.56 (s, 1H, NH), 7.08-7.42 (m, 5H, aromatic).

<sup>13</sup>C NMR (CDCl<sub>3</sub>):  $\delta$  25.9, 26.1, 26.2, 26.3, 26.5, 32.9, 33.1, 33.3 (10 x -CH<sub>2</sub>-), 40.5 (-CH-), 53.9 (CH<sub>2</sub>Ph), 127.7, 127.9, 128.1, 128.2, 128.4, 130.6 (aromatic), 161.8 (C=O).

### 6.3. Synthesis of a trisaccharide probe as a putative virus receptor and a D-glucuronic acid thioglycoside building block

#### General experimental methods

All reactions were performed in oven dried glassware under an argon atmosphere. Solvents and chemicals used were purchased from commercial suppliers. All materials were employed without further purification. Thin layer chromatography (TLC) was carried out on silica gel plates (Silica gel 60, F254, Merck) with detection by UV and visualized by dipping in a 20% solution of sulfuric acid in ethanol followed by heating. Purification by column chromatography was performed using normal-phase silica gel (Silica gel, 230-240 mesh, Merck).  $^1\text{H}$  NMR and  $^{13}\text{C}$  NMR were recorded on a 300 MHz Bruker instrument, and the spectra are referenced to solvent residual signals according to literature values.<sup>181</sup> Chemical shifts are reported as  $\delta$  values (ppm) and the coupling constants ( $J$ ) are given in Hz. Assignments of  $^1\text{H}$  and  $^{13}\text{C}$  resonances were based on COSY and HSQC experiments. Melting point was measured on a Stuart SMP30 apparatus, while optical rotation was measured on a Perkin-Elmer 241 polarimeter. Mass spectrometry was performed on a Waters Aquity UPLC System equipped with PDA and SQD electrospray MS detector.

#### 2-Deoxy-2-(4-methoxybenzylideneamino)- $\alpha/\beta$ -D-glucopyranose (**28**)

D-Glucosamine hydrochloride (**27**) (50.0 g, 0.232 mol) was dissolved in 1 M aqueous sodium hydroxide (240 mL), forming a colorless solution. Anisaldehyde (28.5 mL, 0.235 mol) was added during 5 min while stirring the mixture intensely. The reaction mixture was stirred for 30 min at room temperature. During this time, a thick white suspension was obtained. The suspension was stirred for 2 hours in ice bath. The solid was then collected by filtration and washed with water and with a 1:1 mixture of methanol and ether. The precipitate was dried under vacuum affording **28** (56 g) as a white solid.

Chemical formula: C<sub>14</sub>H<sub>19</sub>NO<sub>6</sub>

Molecular weight: 297.3 g/mol

Yield: 81%

Melting point: 159-160 °C

Literature melting point<sup>139</sup>: 165-166 °C

Optical rotation [ $\alpha$ ]<sub>D</sub> = +29 (c = 0.84, DMSO)

<sup>1</sup>H NMR (DMSO-*d*<sub>6</sub>):  $\delta$  2.81 (t, 1H, *J* = 8.5 Hz), 3.10-3.30 (m, 2H), 3.38-3.55 (m, 2H), 3.71 (dd, 1H, *J* = 5.6 Hz, 11.1 Hz), 3.79 (s, 3H, OCH<sub>3</sub>), 4.59 (t, 1H, *J* = 5.7 Hz), 4.71 (t, 1H, *J* = 7.2 Hz), 4.84 (d, 1H, *J* = 5.6 Hz), 4.95 (d, 1H, *J* = 5.1 Hz), 6.56 (d, 1H, *J* = 6.7 Hz), 6.98 (d, 2H, *J* = 8.7 Hz, aromatic), 7.69 (d, 2H, *J* = 8.7 Hz, aromatic), 8.12 (s, 1H, N=CH).

<sup>13</sup>C NMR (DMSO-*d*<sub>6</sub>):  $\delta$  55.2 (OCH<sub>3</sub>), 61.2 (C-6), 70.3, 74.6, 76.8, 78.1 (C-2, C-3, C-4, C-5), 95.6 (C-1), 113.9, 129.0, 129.6, 161.0 (aromatic), 161.3 (N=CH). NMR data are in accordance with literature values.<sup>206</sup>

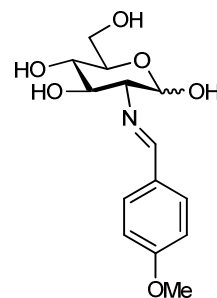

### 1,3,4,6-Tetra-*O*-acetyl-2-(4-methoxybenzylideneamino)-2-deoxy- $\beta$ -D-glucopyranose (**29**)

The solution of **28** (56 g, 0.188 mol) in pyridine (230 mL) was cooled to 0 °C in an ice bath and acetic anhydride (90 mL) was added drop-wise. The mixture was stirred at 0 °C for 4 hours then left at room temperature overnight. The solution was poured into 1.5 L ice, forming a white crystalline solid. The crystals were collected by filtration, washed with water and ether and dried under vacuum to give **29** (74.4 g) as a white solid.

Chemical formula: C<sub>22</sub>H<sub>27</sub>NO<sub>10</sub>

Molecular weight: 465.46 g/mol

Yield: 85%

Melting point: 175-177 °C

Literature melting point<sup>139</sup>: 180-182 °C

Optical rotation [ $\alpha$ ]<sub>D</sub> = +103.4 (c = 1, CHCl<sub>3</sub>)

Literature optical rotation<sup>139</sup> [ $\alpha$ ]<sub>D</sub> = +95 (c = 1, CHCl<sub>3</sub>)

<sup>1</sup>H NMR (CDCl<sub>3</sub>):  $\delta$  1.89 (s, 3H, C(O)CH<sub>3</sub>), 2.03 (s, 3H, C(O)CH<sub>3</sub>), 2.04 (s, 3H, C(O)CH<sub>3</sub>), 2.10 (s, 3H, C(O)CH<sub>3</sub>), 3.45 (dd, 1H, *J*<sub>1,2</sub> = 8.4 Hz, *J*<sub>2,3</sub> = 9.7 Hz, *H*-2), 3.84 (s, 3H, OCH<sub>3</sub>), 3.98 (ddd, 1H, *J*<sub>5,6a</sub> = 2.1 Hz, *J*<sub>5,6b</sub> = 4.6 Hz, *J*<sub>4,5</sub> = 10.1 Hz, *H*-5), 4.13 (dd, 1H, *J*<sub>5,6a</sub> = 2.1 Hz, *J*<sub>6a,6b</sub> = 12.5 Hz, *H*-6b), 4.39 (dd, 1H, *J*<sub>5,6a</sub> = 4.5 Hz, *J*<sub>6a,6b</sub> = 12.4 Hz, *H*-6a), 5.15 (t, 1H, *J* =

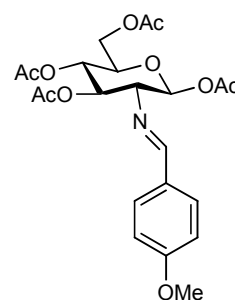

9.8 Hz, *H*-4), 5.44 (t, 1H, *J* = 9.6 Hz, *H*-3), 5.95 (d, 1H, *J*<sub>1,2</sub> = 8.3 Hz, *H*-1), 6.92 (d, 2H, *J* = 8.7 Hz, aromatic), 7.66 (d, 2H, *J* = 8.7 Hz, aromatic), 8.16 (s, 1H, N=CH).

<sup>13</sup>C NMR (CDCl<sub>3</sub>): δ 20.7, 20.8, 20.9, 21.0 (4 x C(O)CH<sub>3</sub>), 55.6 (OCH<sub>3</sub>), 62.0 (*C*-6), 68.2, 72.9, 73.1, 73.4 (*C*-2, *C*-3, *C*-4, *C*-5), 93.3 (*C*-1), 114.2, 128.4, 130.4, 162.5 (aromatic), 164.5 (N=CH), 169.0, 169.8, 170.1, 170.9 (4 x C(O)CH<sub>3</sub>). NMR data are in accordance with literature values.<sup>206</sup>

### 1,3,4,6-Tetra-*O*-acetyl-2-amino-2-deoxy-β-D-glucopyranose (30)

To the hot solution of **29** (70 g, 0.15 mol) in refluxing acetone (70 mL) 5 M HCl (35 mL) was added drop-wise. The mixture was slowly cooled to room temperature resulting in a thick suspension. The suspension was filtered, the solid was washed with acetone and ether. The crude product was dried under vacuum to afford **30** (51.8 g) as a white solid.

Chemical formula: C<sub>14</sub>H<sub>21</sub>NO<sub>9</sub>·HCl

Molecular weight: 383.78 g/mol

Yield: 90%

Literature melting point<sup>139</sup>: 235 °C (decomposition)

Optical rotation [α]<sub>D</sub> = +52.3 (c = 1.01, DMSO)

Literature optical rotation<sup>139</sup> [α]<sub>D</sub> = +32 (c = 1, MeOH)

<sup>1</sup>H NMR (DMSO-*d*<sub>6</sub>): δ 1.97 (s, 3H, C(O)CH<sub>3</sub>), 1.99 (s, 3H, C(O)CH<sub>3</sub>), 2.02 (s, 3H, C(O)CH<sub>3</sub>), 2.17 (s, 3H, C(O)CH<sub>3</sub>), 3.55 (t, 1H, *J*<sub>1,2</sub> = 8.9 Hz, *J*<sub>2,3</sub> = 9.9 Hz, *H*-2), 3.94-4.08 (m, 2H, *H*-5, *H*-6b), 4.19 (dd, 1H, *J*<sub>5,6a</sub> = 4.8 Hz, *J*<sub>6a,6b</sub> = 12.9 Hz, *H*-6a), 4.98 (dd, 1H, *J*<sub>3,4</sub> = 9.2 Hz, *J*<sub>4,5</sub> = 10.0 Hz, *H*-4), 5.37 (dd, 1H, *J*<sub>3,4</sub> = 9.1 Hz, *J*<sub>2,3</sub> = 10.4 Hz, *H*-3), 5.93 (d, 1H, *J*<sub>1,2</sub> = 8.3 Hz, *H*-1), 8.93 (s, br, 3H, NH<sub>3</sub><sup>+</sup>).

<sup>13</sup>C NMR (DMSO-*d*<sub>6</sub>): δ 20.4, 20.5, 20.9, 21.0 (4 x C(O)CH<sub>3</sub>), 52.1 (*C*-2), 61.3 (*C*-6), 67.8, 70.3, 71.6 (*C*-3, *C*-4, *C*-5), 90.1 (*C*-1), 168.7, 169.3, 169.8, 170.0 (4 x C(O)CH<sub>3</sub>). NMR data are in accordance with literature values.<sup>206</sup>

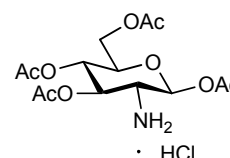

### 1,3,4,6-Tetra-*O*-acetyl-2-deoxy-2-trichloroacetamido-β-D-glucopyranose (31)

To the suspension of **30** (51.8 g, 0.135 mol) in CH<sub>2</sub>Cl<sub>2</sub> (300 mL) Et<sub>3</sub>N (43 mL) was added. The suspension was cooled to 0 °C and trichloroacetyl chloride (17 mL) was added from a dropping funnel keeping the temperature between 5-10 °C. After the mixture was stirred for

30 min, it was diluted with CH<sub>2</sub>Cl<sub>2</sub> (200 mL), washed with water, saturated NaHCO<sub>3</sub> solution, then with water again, dried over MgSO<sub>4</sub>, filtered and evaporated *in vacuo*. The crude product was purified by recrystallization from hexane/EtOAc to afford **31** (52.5 g) as a white solid.

Chemical formula: C<sub>16</sub>H<sub>20</sub>Cl<sub>3</sub>NO<sub>10</sub>

Molecular weight: 492.7 g/mol

Yield: 79%

Melting point: 159-160 °C

Literature melting point<sup>207</sup>: 167.5-168.5 °C

Optical rotation [α]<sub>D</sub> = +3.1 (c = 1.08, CHCl<sub>3</sub>)

Literature optical rotation<sup>208</sup> [α]<sub>D</sub> = +3.5 (c = 1, CHCl<sub>3</sub>)

<sup>1</sup>H NMR (CDCl<sub>3</sub>): δ 2.04 (s, 3H, C(O)CH<sub>3</sub>), 2.06 (s, 3H, C(O)CH<sub>3</sub>), 2.08 (s, 3H, C(O)CH<sub>3</sub>), 2.10 (s, 3H, C(O)CH<sub>3</sub>), 3.88-3.94 (m, 1H, H-5), 4.16 (dd, 1H, J<sub>5,6b</sub> = 2.4 Hz, J<sub>6a,6b</sub> = 12.6 Hz, H-6b), 4.28 (dd, 1H, J<sub>5,6a</sub> = 5.1 Hz, J<sub>6a,6b</sub> = 12.6 Hz, H-6a), 4.34 (m, 1H, H-2), 5.14 (t, 1H, J = 9.6 Hz, H-4), 5.44 (dd, 1H, J = 9.3 Hz, J = 10.8 Hz, H-3), 5.80 (d, 1H, J<sub>1,2</sub> = 8.7 Hz, H-1) 8.93 (d, 1H, J = 9.6 Hz, NH). <sup>1</sup>NMR data are in accordance with literature values.<sup>208</sup>

<sup>13</sup>C NMR (CDCl<sub>3</sub>): δ 20.4, 20.5, 20.6, 20.7 (4 x C(O)CH<sub>3</sub>), 54.2 (C-2), 61.7 (C-6), 68.0, 71.0, 73.0 (C-3, C-4, C-5), 91.8 (C-1), 92.2 (CCl<sub>3</sub>), 162.3 (C(O)CCl<sub>3</sub>), 169.2, 169.3, 170.6, 171.6 (4 x C(O)CH<sub>3</sub>).

MS: *m/z* 493 [M]

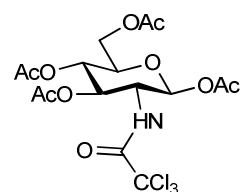

### 3,4,6-Tri-O-acetyl-2-deoxy-2-trichloroacetamido-α-D-glucopyranosyl bromide (**24**)

Trimethylsilyl bromide (1 mL) was added to the ice cold solution of **31** (1 g, 2.03 mmol) in CH<sub>2</sub>Cl<sub>2</sub> (10 mL). The reaction mixture was stirred at room temperature under an argon atmosphere. After 5 hours the reaction mixture was evaporated and the residue was dried at high *vacuo* resulting in **24** (1.02 g) as a white foam. The compound was transferred into the glycosylation reaction without any purification.

Chemical formula: C<sub>14</sub>H<sub>17</sub>BrC<sub>13</sub>NO<sub>8</sub>

Molecular weight: 513.55 g/mol

Yield: 98 %

Optical rotation [α]<sub>D</sub> = +119 (c = 0.87, CHCl<sub>3</sub>)

Literature optical rotation<sup>208</sup> [α]<sub>D</sub> = +129 (c = 1, CHCl<sub>3</sub>)

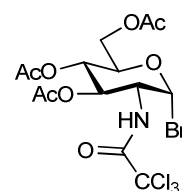

$^1\text{H}$  NMR ( $\text{CDCl}_3$ ):  $\delta$  2.04 (s, 3H,  $\text{C}(\text{O})\text{CH}_3$ ), 2.06 (s, 3H,  $\text{C}(\text{O})\text{CH}_3$ ), 2.10 (s, 3H,  $\text{C}(\text{O})\text{CH}_3$ ), 4.13 (dd, 1H,  $J_{5,6b} = 2$  Hz,  $H$ -6b), 4.25 (m, 1H,  $H$ -2), 4.28 (m, 1H,  $H$ -5), 4.34 (dd, 1H,  $J_{5,6a} = 4.0$  Hz,  $J_{6a,6b} = 12.5$  Hz,  $H$ -6a), 5.28 (dd, 1H,  $J_{4,5} = 10.5$  Hz,  $H$ -4), 5.43 (dd, 1H,  $J_{2,3} = 10.5$  Hz,  $H$ -3), 6.58 (d, 1H,  $J_{1,2} = 4$  Hz,  $H$ -1), 7.02 (d, 1H,  $J = 8.5$  Hz,  $\text{NHC}(\text{O})$ ).  $^1\text{NMR}$  data are in accordance with literature values.<sup>208</sup>

$^{13}\text{C}$  NMR ( $\text{CDCl}_3$ ):  $\delta$  20.4, 20.6, 20.8 (3 x  $\text{C}(\text{O})\text{CH}_3$ ), 55.4 ( $C$ -2), 60.9 ( $C$ -6), 66.2, 70.4, 72.6 ( $C$ -3,  $C$ -4,  $C$ -5), 89.2 ( $C$ -1), 91.5 ( $\text{CCl}_3$ ) 161.9 ( $\text{C}(\text{O})\text{CCl}_3$ ), 169.1, 170.2, 171.2 (3 x  $\text{C}(\text{O})\text{CH}_3$ ).

### Phenyl $\beta$ -D-galactopyranosyl-(1 $\rightarrow$ 4)-2-deoxy-1-thio-2-trichloroacetamido- $\beta$ -D-glucopyranoside (**33**)

Solid sodium methoxide was added to the mixture of **32** (20 g, 24 mmol) in MeOH (250 mL) until the pH of the mixture became around 9. The reaction mixture was stirred for 24 hours at room temperature. Then the mixture was neutralized by treatment with Amberlite IR 120[ $\text{H}^+$ ] ion-exchange resin, the resin was filtered off and washed with methanol. The filtrate was combined and concentrated *in vacuo*. The residue was purified by crystallization to give **33** (15 g) as a white solid.

Chemical formula:  $\text{C}_{20}\text{H}_{26}\text{Cl}_3\text{NO}_{10}\text{S}$

Molecular weight: 578.85 g/mol

Yield: quantitative

Melting point: 160-162  $^\circ\text{C}$

Optical rotation  $[\alpha]_{\text{D}} = -2.2$  ( $c = 1.1$ , MeOH)

$^1\text{H}$  NMR ( $\text{D}_2\text{O}$ ):  $\delta$  3.51 (m, 2H,  $H$ -5,  $H$ -2'), 3.56 (dd, 1H,  $J_{3,4} = 8.2$  Hz,  $J_{4,5} = 10$  Hz,  $H$ -4), 3.65 (m, 2H,  $H$ -3',  $H$ -5'), 3.77 (dd, 1H,  $J_{5,6a} = 5.2$  Hz,  $J_{6a,6b} = 12.3$  Hz,  $H$ -6a), 3.81 (dd, 1H,  $J_{3,4} = 8.2$  Hz,  $J_{2,3} = 10.2$  Hz,  $H$ -3), 3.91 (m, 3H,  $H$ -2,  $H$ -6b,  $H$ -4'), 4.41 (d, 1H,  $J_{1',2'} = 7.8$  Hz,  $H$ -1'), 4.93 (d, 1H,  $J_{1,2} = 10.5$  Hz,  $H$ -1), 7.47-7.49 (m, 3H, aromatic), 7.63-7.65 (m, 2H, aromatic).

$^{13}\text{C}$  NMR ( $\text{D}_2\text{O}$ ):  $\delta$  53.8 ( $C$ -2), 63.3, 63.5 ( $C$ -6 and  $C$ -6'), 71.2, ( $C$ -4), 71.3 ( $C$ -4'), 75.2, 78.0 ( $C$ -3',  $C$ -5'), 82.3 ( $C$ -5), 86.3 ( $C$ -3), 88.8 ( $C$ -1), 94.2 ( $\text{CCl}_3$ ), 104.3 ( $C$ -1'), 130.9, 132.2, 134.3, 135.5 (aromatic), 162.4 ( $\text{C}(\text{O})\text{CCl}_3$ ).

MS:  $m/z$  578 [M]

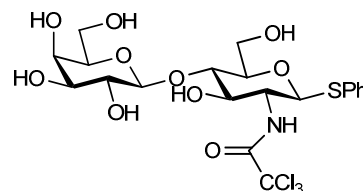

**Phenyl 2,6-di-O-benzoyl-3,4-O-isopropylidene-β-D-galactopyranosyl-(1→4)-3,6-di-O-benzoyl-2-deoxy-1-thio-2-trichloroacetamido-β-D-glucopyranoside (35)**

A mixture of **33** (15 g, 26 mmol), acetone (150 mL) and trimethylsilyl chloride (1.7 mL) was stirred at room temperature under an argon atmosphere. After 3 hours the mixture was suspended with Et<sub>2</sub>O and evaporated *in vacuo*. The residue **34** was used for the next step without any purification.

Benzoyl chloride (25 mL, 208 mmol) was added dropwise to the ice-cold solution of **34** (26 mmol) in pyridine (200 mL). The reaction mixture was stirred at room temperature under an argon atmosphere. After 1 day a little water was added and the mixture was stirred for an additional 30 minutes, then concentrated *in vacuo*. The residue was dissolved in CH<sub>2</sub>Cl<sub>2</sub>, washed with 2 M HCl solution, sat. NaHCO<sub>3</sub> solution, three times with water, dried over MgSO<sub>4</sub>, filtered and evaporated *in vacuo*. Purification by column chromatography afforded **35** as a white solid.

Chemical formula: C<sub>51</sub>H<sub>46</sub>Cl<sub>3</sub>NO<sub>14</sub>S

Molecular weight: 1035.36 g/mol

Yield: 78%

Melting point: 141-143 °C

Optical rotation [α]<sub>D</sub> = +12 (c = 1, CHCl<sub>3</sub>)

<sup>1</sup>H NMR (CDCl<sub>3</sub>): δ 1.25 (s, 3H, CCH<sub>3</sub>), 1.49 (s, 3H, CCH<sub>3</sub>), 3.82 (m, 3H, H-5', H-5, H-6b), 4.11 (m, 2H, H-4', H-4), 4.21-4.40 (m, 4H, H-3', H-2, H-6a', H-6b), 4.6 (m, 2H, H-1' and H-6a'), 4.86 (d, 1H, J<sub>1,2</sub> = 10.2 Hz, H-1), 5.12 (t, 1H, J = 7.2 Hz, H-2'), 5.58 (t, 1H, J = 9.6 Hz, H-3), 7.11 (d, 1H, J = 7.5 Hz, NH), 7.20-7.59 (m, 15H, aromatic), 7.89-8.04 (m, 10H, aromatic).

<sup>13</sup>C NMR (CDCl<sub>3</sub>): δ 26.1 (CCH<sub>3</sub>), 27.4 (CCH<sub>3</sub>), 54.5 (C-2), 62.6 and 62.7 (C-6 and C-6'), 71.4 (C-5 or C-5'), 73.0, 73.5, 73.6 75.2, 76.9, 77.2 (C-3, C-2', C-3', C-4, C-4', C-5 or C-5'), 86.2 (C-1), 92.1 (CCl<sub>3</sub>), 100.5 (C-1'), 110.9 (C(CH<sub>3</sub>)<sub>2</sub>), 128.3, 128.4, 128.7, 128.8, 129.07, 129.3, 129.4, 129.5, 129.7, 129.9, 131.5, 133.1, 133.3, 133.4, 133.5 (aromatic), 161.8 (C(O)CCl<sub>3</sub>), 164.9, 165.8, 166.0, 166.8 (4 x C(O)Ph).

MS: *m/z* 1036 [M+H]

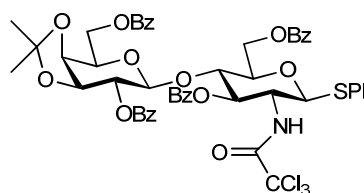



**Phenyl 2,3-di-O-benzoyl-4,6-O-isopropylidene-β-D-galactopyranosyl-(1→4)-3,6-di-O-benzoyl-2-deoxy-1-thio-2-trichloroacetamido-β-D-glucopyranoside**

Chemical formula: C<sub>51</sub>H<sub>46</sub>Cl<sub>3</sub>NO<sub>14</sub>S

Molecular weight: 1035.36 g/mol

Melting point: 152-154 °C

Optical rotation [α]<sub>D</sub> = +47.8 (c = 0.7, CHCl<sub>3</sub>)

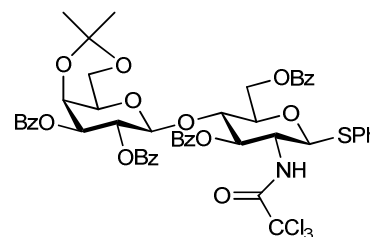

<sup>1</sup>H NMR (acetone-*d*<sub>6</sub>): δ 1.22 (s, 3H, CCH<sub>3</sub>), 1.23 (s, 3H, CCH<sub>3</sub>), 3.33 (m, 2H, H-5', H-6a'), 3.71 (dd, 1H, *J*<sub>5,6b</sub> = 2.1 Hz, *J*<sub>6a,6b</sub> = 12.6 Hz, H-6b'), 4.01 (m, 1H, H-5), 4.20 (dd, 1H, *J*<sub>1,2</sub> = 10.2 Hz, *J*<sub>2,3</sub> = 9.9 Hz, H-2) 4.34-4.46 (m, 3H, H-4, H-4', H-6a), 4.78 (dd, 1H, *J*<sub>5',6b'</sub> = 2.1 Hz, *J*<sub>6a',6b'</sub> = 12.0 Hz, H-6b), 5.23 (d, 1H, *J*<sub>1',2'</sub> = 7.8 Hz, H-1'), 5.36 (m, 2H, H-1, H-3'), 5.69 (dd, 1H, *J*<sub>1',2'</sub> = 8.1 Hz, *J*<sub>2',3'</sub> = 10.5 Hz, H-2'), 5.81 (dd, 1H, *J*<sub>3,4</sub> = 9.0 Hz, *J*<sub>2,3</sub> = 9.9 Hz, H-3), 7.06-7.65 (m, 17H, aromatic), 7.87-8.16 (m, 8H, aromatic), 8.44 (d, 1H, *J* = 9.6 Hz, NH).

<sup>13</sup>C NMR (acetone-*d*<sub>6</sub>): δ 20.1, 20.2 (2 x CCH<sub>3</sub>), 56.8 (C-2), 63.2 and 64.5 (C-6 and C-6'), 68.2, 68.3, 71.8, 74.6, 76.5, 78.5 78.7 (C-3, C-4, C-5, C-2', C-3', C-4', C-5'), 87.3 (C-1), 94.4 (CCl<sub>3</sub>), 100.1 (C-1'), 103.0 (C(CH<sub>3</sub>)<sub>2</sub>), 129.4, 130.1, 130.2, 130.3, 130.5, 131.0, 131.1, 131.2, 131.3, 131.5, 131.6, 131.8, 133.7, 134.5, 134.8, 135.1 (aromatic), 163.1 (C(O)CCl<sub>3</sub>), 166.8, 166.9, 167.0, 167.1 (4 x C(O)Ph).

**Phenyl 2,6-di-O-benzoyl-β-D-galactopyranosyl-(1→4)-3,6-di-O-benzoyl-2-deoxy-1-thio-2-trichloroacetamido-β-D-glucopyranoside (25)**

The solution of **35** (10 g, 9.6 mmol) in CH<sub>2</sub>Cl<sub>2</sub> (120 mL) was cooled to 0 °C and 90 % TFA (30 mL) was added dropwise. The reaction mixture was stirred at 0 °C for 30 minutes, then at room temperature. After 3 hours the mixture was neutralized with solid NaHCO<sub>3</sub> and evaporated *in vacuo*. The residue was dissolved in CH<sub>2</sub>Cl<sub>2</sub> (500 mL), washed with sat. NaHCO<sub>3</sub> solution, water, dried over MgSO<sub>4</sub>, filtered and concentrated *in vacuo*. The residue was purified by column chromatography to give **25** (8.7 g) as a white solid.

Chemical formula: C<sub>48</sub>H<sub>42</sub>Cl<sub>3</sub>NO<sub>14</sub>S

Molecular weight: 995.27 g/mol

Yield: 91 %

Melting point: 158-160 °C

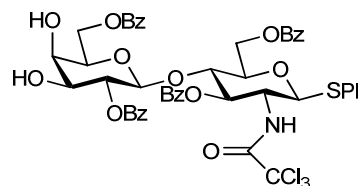

Optical rotation  $[\alpha]_D = +10.5$  ( $c = 1$ ,  $\text{CHCl}_3$ )

$^1\text{H}$  NMR (acetone- $d_6$ ):  $\delta$  2.88 (s, 2H, 2 x OH), 3.85 (m, 1H, H-5), 3.90-3.97 (m, 3H, H-3', H-5', H-6b), 4.21-4.33 (m, 4H, H-2, H-4, H-6a, H-4'), 4.55 (dd, 1H,  $J_{5',6a'} = 6.5$  Hz,  $J_{6a',6b'} = 12.0$  Hz, H-6a'), 4.70 (dd, 1H,  $J_{5',6b'} = 1.5$  Hz,  $J_{6a',6b'} = 12.0$  Hz, H-6b'), 4.91 (d, 1H,  $J_{1',2'} = 8$  Hz, H-1'), 5.32 (dd, 1H,  $J_{1',2'} = 8$  Hz,  $J_{2',3'} = 9.5$  Hz, H-2'), 5.35 (d, 1H,  $J_{1,2} = 10.5$  Hz, H-1), 5.72 (t, 1H,  $J = 9.5$  Hz, H-3), 7.11-7.23 (m, 3H, aromatic), 7.35-7.56 (m, 12 H, aromatic), 7.62-7.68 (m, 2H, aromatic), 7.92-7.81 (m, 8H, aromatic).

$^{13}\text{C}$  NMR (acetone- $d_6$ ):  $\delta$  56.8 (C-2), 64.7, 64.8 (C-6, C-6'), 70.6, 73.6, 74.8, 75.1, 75.6, 77.7, 79.0 (C-3, C-4, C-5, C-2', C-3', C-4', C-5'), 87.2 (C-1), 94.5 ( $\text{CCl}_3$ ), 103.1 (C-1'), 129.4, 130.0, 130.2, 130.4, 130.5, 130.7, 131.2, 131.4, 131.6, 131.7, 131.9, 132.1, 132.2, 133.6, 134.8, 135.0 (aromatic), 163.3 (NHCO), 166.8, 167.2, 167.3, 167.4 (4 x  $\text{COCH}_3$ ).

MS:  $m/z$  995 [M]

### Phenyl *O*-(2,4,6-tri-*O*-benzoyl- $\beta$ -D-galactopyranosyl)-(1 $\rightarrow$ 4)-3,6-di-*O*-benzoyl-2-deoxy-1-thio-2-trichloroacetamido- $\beta$ -D-glucopyranoside (**26**)

Trimethyl orthobenzoate (0.7 mL) and *p*TsOH (115 mg) were added to the solution of **25** (2 g, 2 mmol) in acetonitrile (20 mL). The reaction mixture was stirred at room temperature under argon atmosphere. After 3 hours the mixture was evaporated *in vacuo*. The residue was dissolved in 20 mL acetic acid/water (4/1) and stirred for 2 hours at room temperature. Then, the mixture was concentrated *in vacuo*, the residue was dissolved in  $\text{CH}_2\text{Cl}_2$ , washed with saturated  $\text{NaHCO}_3$  solution, water, dried over  $\text{MgSO}_4$ , filtered and evaporated *in vacuo*. Purification by column chromatography afforded **26** (1.36 g) as a white solid.

Chemical formula:  $\text{C}_{55}\text{H}_{46}\text{Cl}_3\text{NO}_{15}\text{S}$

Molecular weight: 1099.38 g/mol

Yield: 62 %

Melting point: 149-151  $^\circ\text{C}$

Optical rotation  $[\alpha]_D = +29$  ( $c = 0.4$ ,  $\text{CHCl}_3$ )

$^1\text{H}$  NMR ( $\text{CDCl}_3$ ):  $\delta$  3.0 (s, 1H, OH), 3.57 (dd, 1H,  $J_{5,6a'} = 6.6$  Hz,  $J_{6a',6b'} = 10.5$  Hz, H-6a'), 3.78 (m, 2H, H-6a', H-5), 4.02 (m, 2H, H-3', H-4), 4.14 (m, 1H, H-5'), 4.21 (dd, 1H,  $J_{1,2} = 10.2$  Hz,  $J_{2,3} = 9.6$  Hz, H-2), 4.42 (dd, 1H,  $J_{5,6a} = 5.6$  Hz,  $J_{6a,6b} = 12.3$  Hz, H-6a), 4.57 (dd, 1H,  $J_{5,6b} = 1.8$  Hz,  $J_{6a,6b} = 12.3$  Hz, H-6b), 4.72 (d, 1H,  $J_{1',2'} = 8.1$  Hz, H-1'), 4.84 (d, 1H,  $J_{1,2} =$

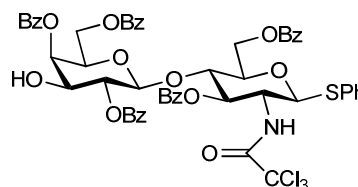

10.2 Hz, H-1), 5.25 (t, 1H,  $J = 7.8$  Hz, H-2'), 5.54 (m, 2H, H-3, H-4'), 7.05-7.90 (m, 30H, aromatic).

$^{13}\text{C}$  NMR ( $\text{CDCl}_3$ ):  $\delta$  54.4 (C-2), 61.5 (C-6'), 62.8 (C-6), 70.0, 71.4, 71.6, 73.5, 73.7, 75.6, 77.2 (C-2', C-3, C-3', C-4, C-4', C-5, C-5'), 86.3 (C-1), 92.1 ( $\text{CCl}_3$ ), 100.8 (C-1'), 128.2, 128.4, 128.5, 128.6, 128.8, 129.0, 129.3, 129.4, 129.6, 129.7, 129.8, 129.9, 131.7, 132.9, 133.4, 133.5 (aromatic), 161.8 ( $\text{C}(\text{O})\text{CCl}_3$ ), 165.7, 165.9, 166.1, 166.6 (4 x  $\text{C}(\text{O})\text{Ph}$ ).

**Phenyl 3,4,6-tri-*O*-acetyl-2-deoxy-2-trichloroacetamido- $\beta$ -D-glucopyranosyl-(1 $\rightarrow$ 3)-2,4,6-tri-*O*-benzoyl- $\beta$ -D-galactopyranosyl-(1 $\rightarrow$ 4)-3,6-di-*O*-benzoyl-2-deoxy-1-thio-2-trichloroacetamido- $\beta$ -D-glucopyranoside (**23**)**

The solution of the donor **24** (0.7g, 1.35 mmol), the acceptor **26** (1 g, 0.9 mmol) and freshly activated 4Å molecular sieves in  $\text{CH}_2\text{Cl}_2$  (15 mL) was stirred for 30 minutes under an argon atmosphere, then cooled to  $-45$  °C. Silver triflate (520 mg, 2 mmol) was added at that temperature, and then the reaction mixture was stirred at  $-30$  °C under argon atmosphere. After 4 hours the mixture was neutralized with saturated  $\text{NaHCO}_3$  solution and filtered through Celite. The mixture was diluted with  $\text{CH}_2\text{Cl}_2$ , washed with sat.  $\text{NaHCO}_3$  solution and water, dried over  $\text{MgSO}_4$ , filtered and evaporated *in vacuo*. The residue was purified by column chromatography to give **23** (978 mg) as a white solid.

Chemical formula:  $\text{C}_{69}\text{H}_{62}\text{Cl}_6\text{N}_2\text{O}_{23}\text{S}$

Molecular weight: 1532.01 g/mol

Yield: 71%

Melting point: 180-182 °C

Optical rotation  $[\alpha]_{\text{D}} = +5.8$  ( $c = 1$ ,  $\text{CHCl}_3$ )

$^1\text{H}$  NMR ( $\text{CDCl}_3$ ):  $\delta$  1.85 (s, 3H,  $\text{C}(\text{O})\text{CH}_3$ ), 1.90 (s, 3H,  $\text{C}(\text{O})\text{CH}_3$ ), 1.92 (s, 3H,  $\text{C}(\text{O})\text{CH}_3$ ), 3.30 (dd, 1H,  $J_{5',6a'} = 4.8$  Hz,  $J_{6a',6b'} = 6.9$  Hz, H-6a'), 3.55 (m, 2H, H-2'', H-5''), 3.74 (m, 2H, H-5, H-5'), 4.03-4.08 (m, 4H, H-4, H-3', H-6b', H-6a''), 4.12 (dd, 1H,  $J_{5'',6b''} = 1.2$  Hz,  $J_{6a'',6b''} = 7.5$  Hz, H-6b''), 4.23 (q, 1H,  $J_{2,3} = 3$  Hz,  $J_{1,2} = 7.2$  Hz, H-2), 4.34 (dd, 1H,  $J_{5,6b} = 3$  Hz,  $J_{6a,6b} = 7.5$  Hz, H-6b), 4.48 (d, 1H,  $J = 6.3$  Hz, H-6a), 4.63 (d, 1H,  $J = 5.8$  Hz, H-1'), 4.92 (m, 3 H, H-1, H-1'', H-4''), 5.25 (t, 1H,  $J = 5.7$  Hz, H-3), 5.47 (dd, 1H,  $J_{1',2'} = 5.7$  Hz,  $J_{2',3'} = 4.5$  Hz, H-2'), 5.58 (m, 2H, H-4', H-3''), 6.57 (d, 1H,  $J = 5.1$  Hz,  $\text{NH}''$ ), 6.94 (d, 1H,  $J = 4.8$  Hz,  $\text{NH}$ ), 7.10-7.59 (m, 20H, aromatic), 7.80-8.05 (m, 10 H, aromatic).

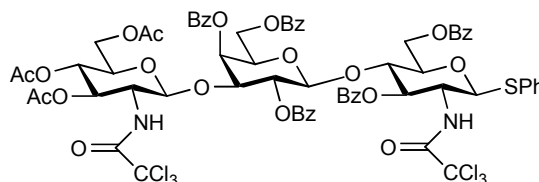

$^{13}\text{C}$  NMR ( $\text{CDCl}_3$ ):  $\delta$  20.4, 20.5, 20.6 (3 x  $\text{C}(\text{O})\text{CH}_3$ ), 54.1 (C-2), 56.4(C-2''), 61.2, 61.8, 62.5 (C-6, C-6', C-6''), 68.1 (C-4''), 69.3 (C-4'), 70.5 (C-3''), 71.5 (C-2'), 71.8, 71.9 (C-5', C-5''), 73.6 (C-3), 75.3, 76.7, 76.9 (C-4, C-5, C-3'), 85.9 (C-1), 91.5, 92.1 (2 x  $\text{CCl}_3$ ), 99.2 (C-1''), 100.8 (C-1'), 128.0, 128.5, 128.7, 128.9, 129.0, 129.1, 129.3, 129.4, 129.5, 129.7, 129.8, 130.0, 131.3, 133.2, 133.3, 133.4, 133.7 (aromatic), 161.6, 161.8 (2 x  $\text{C}(\text{O})\text{CCl}_3$ ), 164.7, 165.1, 165.8, 165.9, 166.6, 169.2, 170.3, 170.6 (8 x  $\text{C}=\text{O}$ ).

MS:  $m/z$  1532 [M]

**Phenyl 3,4,6-tri-*O*-acetyl-2-deoxy-2-trichloroacetamido- $\beta$ -D-glucopyranosyl-(1 $\rightarrow$ 3)-[4-*O*-(3,4,6-tri-*O*-acetyl-2-deoxy-2-trichloroacetamido- $\beta$ -D-glucopyranosyl)-2,6-di-*O*-benzoyl- $\beta$ -D-galactopyranosyl]-(1 $\rightarrow$ 4)-3,6-di-*O*-benzoyl-2-deoxy-1-thio-2-trichloroacetamido- $\beta$ -D-glucopyranoside (38)**

Chemical formula:  $\text{C}_{76}\text{H}_{74}\text{Cl}_9\text{N}_3\text{O}_{30}\text{S}$

Molecular weight: 1860.54 g/mol

Melting point: 158-160  $^\circ\text{C}$

Optical rotation  $[\alpha]_{\text{D}} = -6.2$  ( $c = 0.8$ ,  $\text{CHCl}_3$ )

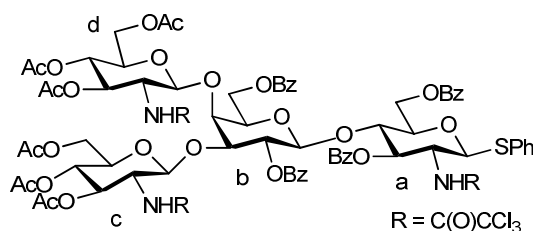

$^1\text{H}$  NMR ( $\text{CDCl}_3$ ):  $\delta$  1.75-1.98 (m, 18H, 6 x  $\text{CCH}_3$ ), 3.33-4.26 (m, 18H), 4.48 (d, 1H,  $J = 7.5$  Hz, H-1<sup>b</sup>), 4.74 (d, 1H,  $J = 10.5$  Hz, H-1<sup>a</sup>), 4.88-4.95 (m, 2H, H-4<sup>c</sup>, H-4<sup>d</sup>), 5.08 (d, 1H,  $J = 7.8$  Hz, H-1<sup>c</sup> or H-1<sup>d</sup>), 5.28 (m, 1H, H-2<sup>b</sup>), 5.46-5.69 (m, 4H, H-3<sup>a</sup>, H-3<sup>c</sup>, H-3<sup>d</sup>, H-1<sup>c</sup> or H-1<sup>d</sup>) 7.10-7.97 (m, 15H, aromatic).

$^{13}\text{C}$  NMR ( $\text{CDCl}_3$ ):  $\delta$  20.2, 20.3, 20.4, 2 x 20.5, 20.6 (6 x  $\text{CCH}_3$ ), 54.0, 54.1, 54.3 (C-2<sup>a</sup>, C-2<sup>c</sup>, C-2<sup>d</sup>), 56.4, 57.1, 61.4, 61.9 (C-6<sup>a</sup>, C-6<sup>b</sup>, C-6<sup>c</sup>, C-6<sup>d</sup>), 68.7, 68.8, 70.0, 70.6, 70.7, 71.1, 71.2, 72.2, 72.4, 73.6, 74.5, 74.7, 76.2 78.7, 84.5 (C-1<sup>a</sup>), 91.5, 92.1, 92.7 (3 x  $\text{CCl}_3$ ), 97.8, 100.7 (C-1<sup>c</sup>, C-1<sup>d</sup>), 102.2 (C-1<sup>b</sup>), 128.2, 128.4, 128.8, 128.9, 129.1, 129.2, 129.3, 129.5, 129.6, 129.7, 130.0, 133.2, 133.5, 133.6, 134.2 (aromatic), 161.6, 161.7, 161.9 (3 x  $\text{C}(\text{O})\text{CCl}_3$ ), 164.9, 165.1, 165.9, 166.8, 169.4, 169.5, 169.9, 170.1, 170.2, 170.5 (10 x  $\text{C}=\text{O}$ ).

MS:  $m/z$  1883 [M + Na]

**Phenyl 2-acetamido-2-deoxy-β-D-glucopyranosyl-(1→3)-β-D-galactopyranosyl-(1→4)-2-acetamido-2-deoxy-1-thio-β-D-glucopyranoside (39)**

The protected trisaccharide **23** (600 mg, 0.4 mmol) was dissolved in 20 % aqueous methanol (6 mL), NaOH (150 mg) was added and the mixture was stirred until the compound was completely dissolved. The reaction mixture was stirred at 40 °C for 8 hours and for 14 hours at room temperature. The mixture was cooled to 0 °C and Ac<sub>2</sub>O was added dropwise to pH 6 (against the universal pH indicator, Merck). The mixture was deionized by the treatment with the cation-exchange resin KU-2 [H<sup>+</sup>]. The resin was filtered off and washed with methanol. The filtrate was concentrated *in vacuo* and the residue was purified by column chromatography to afford **39** (206 mg) as a white amorphous powder.

Chemical formula: C<sub>28</sub>H<sub>42</sub>N<sub>2</sub>O<sub>15</sub>S

Molecular weight: 678.7 g/mol

Yield: 76 %

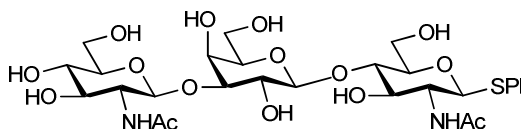

Optical rotation  $[\alpha]_D = -24$  (c = 0.4, H<sub>2</sub>O)

<sup>1</sup>H NMR (D<sub>2</sub>O): δ 1.94 (s, 3H, CH<sub>3</sub>CO), 1.96 (s, 3H, CH<sub>3</sub>CO), 3.37-3.39 (m, 2H, H-4, H-4''), 3.43-3.54 (m, 3H, H-2', H-5', H-3''), 3.58-3.76 (m, 10H, H-2, H-3, H-5, H-6a, H-6b, H-3', H-6b', H-2'', H-5'', H-6b''), 3.78-3.94 (m, 2H, H-6a', H-6a''), 4.07 (d, 1H, J = 3Hz, H-4'), 4.37 (m, 2H, H-1, H-1'), 4.60 (d, 1H, J<sub>1'',2''</sub> = 8 Hz, H-1'') 7.20-7.22 m (3H, aromatic), 7.38-7.42 (m, 2H, aromatic).

<sup>13</sup>C NMR (D<sub>2</sub>O): δ 22.2 (CH<sub>3</sub>CO), 22.3 (CH<sub>3</sub>CO), 54.9 (C-2), 55.7 (C-2''), 60.1, 60.5, 60.9 (C-6, C-6', C-6''), 68.3 (C-4'), 69.7 (C-4''), 70.0 (C-5), 72.5 (C-5'), 73.6 (C-2'), 74.8, 74.9 (C-3'', C-5''), 75.4 (C-4), 78.5 (C-3), 82.0 (C-3'), 101.9 (C-1), 102.8, 102.9 (C-1', C-1''), 127.7, 128.8, 132.0, 132.9 (aromatic), 174.7 (CH<sub>3</sub>CO), 175.0 (CH<sub>3</sub>CO).

**O-(2-Acetamido-2-deoxy-β-D-glucopyranosyl)-(1→3)-O-β-galactopyranosyl-(1→4)-2-acetamido-2-deoxy-D-glucopyranose (18)**

*N*-Bromosuccinimide (106 mg, 0.6 mmol) was added at room temperature to the stirred solution of the phenyl thioglycoside **39** (200 mg, 0.3 mmol) in 4:1 acetone-water (3 mL). The reaction mixture was stirred for 2 hours at room temperature. Then, the solvent was evaporated *in vacuo*, the residue was purified by column chromatography to give **18** (111 mg) as a white solid.

Chemical formula: C<sub>22</sub>H<sub>38</sub>N<sub>2</sub>O<sub>16</sub>

Molecular weight: 586.54 g/mol

Yield: 63 %

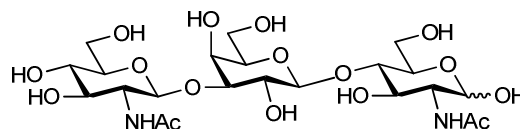

<sup>1</sup>H NMR (D<sub>2</sub>O): δ 1.96 (s, 3H, CH<sub>3</sub>), 1.97 (s, 3H, CH<sub>3</sub>), 3.45-4.11 (m, 18H), 4.39 (d, 1H, J<sub>1'',2''</sub> = 7.8 Hz, H-1''), 4.51 (d, 1H, J<sub>1',2'</sub> = 8.6 Hz, H-1'), 4.53 (d, 0.48H, J<sub>1,2</sub> = 8.5 Hz, H-1β), 5.12 (d, 0.52H, J<sub>1,2</sub> = 3.6 Hz, H-1α).

<sup>13</sup>C NMR (D<sub>2</sub>O): δ 22.5, 22.9 (2 x CH<sub>3</sub>CO), 53.7 (C-2), 55.4 (C-2''), 60.1, 60.3, 60.7 (C-6, C-6', C-6''), 67.0, 68.3, 69.5, 69.6, 70.3, 74.2, 75.1, 76.7, 81.4, 81.6, 90.2 (C-1α), 92.7 (C-1β), 101.9 (C-1''), 103.5 (C-1'), 175.3, 175.6 (2 x COCH<sub>3</sub>).

MS: *m/z* 587 [M+H]

#### Ethyl 2,3,4,6-tetra-*O*-acetyl-1-thio-β-D-glucopyranoside (**44**)

Ethyl mercaptan (3.3 mL) was added to a stirred solution of 1,2,3,4,6-penta-*O*-acetyl-β-D-glucopyranose (**43**) (14 g, 35.8 mmol) in CH<sub>2</sub>Cl<sub>2</sub> (100 mL) with freshly activated 4Å molecular sieves. The mixture was cooled at 0 °C and BF<sub>3</sub>·Et<sub>2</sub>O (12.9 mL) was added. The reaction mixture was stirred at room temperature under argon. After 4 hours the mixture was filtered through Celite. The filtrate was diluted with CH<sub>2</sub>Cl<sub>2</sub>, neutralized with sat. NaHCO<sub>3</sub>, washed with water, dried over MgSO<sub>4</sub>, filtered and evaporated *in vacuo*. The residue was crystallized from EtOAc/hexane to afford **44** (10.3 g) as a white solid.

Chemical formula: C<sub>16</sub>H<sub>24</sub>O<sub>9</sub>S

Molecular weight: 392.42 g/mol

Yield: 76 %

Melting point: 78-80 °C

Literature melting point<sup>209</sup>: 82-83 °C

Optical rotation [α]<sub>D</sub> = -18.7 (c = 0.64, CHCl<sub>3</sub>)

Literature optical rotation<sup>209</sup>[α]<sub>D</sub> = -25.6 (c = 1.0, CHCl<sub>3</sub>)

<sup>1</sup>H NMR (CDCl<sub>3</sub>): δ 1.25 (t, 3H, J = 7.5 Hz, SCH<sub>2</sub>CH<sub>3</sub>), 1.98 (s, 3H, C(O)CH<sub>3</sub>), 2.00 (s, 3H, C(O)CH<sub>3</sub>), 2.04 (s, 3H, C(O)CH<sub>3</sub>), 2.05 (s, 3H, C(O)CH<sub>3</sub>), 2.62-2.75 (m, 2H, SCH<sub>2</sub>CH<sub>3</sub>), 3.69 (m, 1H, H-5), 4.11 (dd, 1H, J<sub>5,6a</sub> = 2.4 Hz, J<sub>6a,6b</sub> = 12.3 Hz, H-6b), 4.22 (dd, 1H, J<sub>5,6b</sub> = 5.1 Hz, J<sub>6a,6b</sub> = 12.3 Hz, H-6a), 4.47 (d, 1H, H-1, J<sub>1,2</sub> = 9.9 Hz), 4.98-5.10 (m, 2H, H-2, H-3), 5.20 (t, 1H, J = 9.3 Hz, H-4).

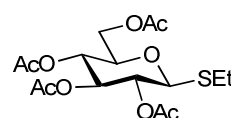

$^{13}\text{C}$  NMR ( $\text{CDCl}_3$ ):  $\delta$  14.6 ( $\text{SCH}_2\text{CH}_3$ ) 20.0, 20.1, 20.2, 20.3 (4 x  $\text{CH}_3$ ), 23.6 ( $\text{SCH}_2\text{CH}_3$ ), 61.8 (C-6), 68.1, 69.3, 73.5, 75.4 (C-2, C-3, C-4, C-5), 83.1 (C-1), 168.9, 169.1, 169.8, 170.2 (4 x  $\text{C}(\text{O})\text{CH}_3$ ). NMR data are in accordance with literature values.<sup>209</sup>

### Ethyl 1-thio- $\beta$ -D-glucopyranoside (45)

Solid NaOMe was added to the ethyl 2,3,4,6-tetra-*O*-acetyl-1-thio- $\beta$ -D-glucopyranoside (**44**) (9.3 g, 23.7 mmol) in MeOH (100 mL) until the pH became around 9. The reaction mixture was stirred at room temperature for 18 hours. Then the mixture was neutralized by treatment with Amberlite IR 120 [ $\text{H}^+$ ] ion-exchange resin, the resin was filtered off and washed with methanol. The filtrate was combined and concentrated *in vacuo*. The residue was crystallized from EtOH to give **45** (5.4 g) as a white solid.

Chemical formula:  $\text{C}_8\text{H}_{16}\text{O}_5\text{S}$

Molecular weight: 224.27 g/mol

Yield: quantitative

Melting point: 93-95 °C

Literature melting point<sup>210</sup>: 99.5-100.5 °C

Optical rotation  $[\alpha]_{\text{D}} = -52.3$  ( $c = 1$ ,  $\text{H}_2\text{O}$ )

Literature optical rotation<sup>210</sup>  $[\alpha]_{\text{D}} = -57$  ( $c = 1.0$ ,  $\text{H}_2\text{O}$ )

$^1\text{H}$  NMR ( $\text{CDCl}_3$ ):  $\delta$  1.26 (t, 3H,  $J = 7.5$  Hz,  $\text{SCH}_2\text{CH}_3$ ), 2.73 (m, 2H,  $\text{SCH}_2\text{CH}_3$ ), 3.26-3.52 (m, 4H, H-2, H-3, H-4, H-5), 3.68 (dd, 1H,  $J_{5,6a} = 4.9$  Hz,  $J_{6a,6b} = 10.4$  Hz, H-6a), 4.92 (dd, 1H,  $J_{5,6b} = 2.2$  Hz,  $J_{6a,6b} = 10.4$  Hz, H-6b), 4.48 (d, 1H,  $J_{1,2} = 9.3$  Hz, H-1).

$^{13}\text{C}$  NMR ( $\text{CDCl}_3$ ):  $\delta$  15.3 ( $\text{SCH}_2\text{CH}_3$ ), 24.6 ( $\text{SCH}_2\text{CH}_3$ ), 61.7 (C-6), 70.8, 73.1, 78.3, 80.7 (C-2, C-3, C-4, C-5), 86.6 (C-1). NMR data are in accordance with literature values.<sup>211</sup>

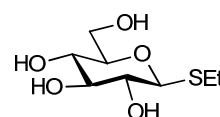

### Ethyl 2,3,4,6-tetra-*O*-trimethylsilyl-1-thio- $\beta$ -D-glucopyranoside (46)

Trimethylsilyl chloride (TMSCl) (20 mL) was added to a 1 M solution of ethyl 1-thio- $\beta$ -D-glucopyranoside (**45**) (5.4 g, 24 mmol) in dry pyridine (50 mL). The reaction mixture was stirred for 24 hours at room temperature, then water was added to decompose the unreacted TMSCl. The mixture was diluted with  $\text{CH}_2\text{Cl}_2$ , the organic layer was washed twice with  $\text{H}_2\text{O}$ , dried over  $\text{MgSO}_4$ , filtered and evaporated *in vacuo*. The pyridine was removed by

coevaporation twice with toluene to give 9.83 g of the expected persilylated glycoside **46** as yellow syrup.

Chemical formula: C<sub>20</sub>H<sub>48</sub>O<sub>5</sub>SSi<sub>4</sub>

Molecular weight: 513.0 g/mol

Yield: 80 %

Optical rotation [ $\alpha$ ]<sub>D</sub> = +80.2 (c = 1, CHCl<sub>3</sub>)

<sup>1</sup>H NMR (CDCl<sub>3</sub>):  $\delta$  0.10 (s, 9H, Si(CH<sub>3</sub>)<sub>3</sub>), 0.14 (s, 9H, Si(CH<sub>3</sub>)<sub>3</sub>), 0.16 (s, 9H, Si(CH<sub>3</sub>)<sub>3</sub>), 0.20 (s, 9H, Si(CH<sub>3</sub>)<sub>3</sub>), 1.27 (t, 3H, *J* = 7.5 Hz, SCH<sub>2</sub>CH<sub>3</sub>), 2.70 (q, 2H, SCH<sub>2</sub>CH<sub>3</sub>), 3.23-3.42 (m, 4H, H-2, H-3, H-4, H-5), 3.62 (dd, 1H, *J*<sub>5,6a</sub> = 6.0 Hz, *J*<sub>6a,6b</sub> = 11.1 Hz, H-6a), 3.77 (dd, 1H, *J*<sub>5,6b</sub> = 3.3 Hz, *J*<sub>6a,6b</sub> = 11.1 Hz, H-6b), 4.41 (d, 1H, H-1, *J*<sub>1,2</sub> = 8.8 Hz).

<sup>13</sup>C NMR (CDCl<sub>3</sub>):  $\delta$  0.3, 0.7, 1.0, 1.4 (4x Si(CH<sub>3</sub>)<sub>3</sub>), 15.1 (SCH<sub>2</sub>CH<sub>3</sub>), 24.7 (SCH<sub>2</sub>CH<sub>3</sub>), 62.9 (C-6), 73.1, 75.7, 78.9, 81.7 (C-2, C-3, C-4, C-5), 87.3 (C-1). NMR data are in accordance with literature values.<sup>156</sup>

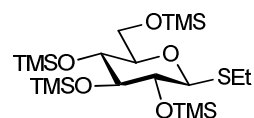

### Ethyl 2-O-benzoyl-3-O-benzyl-4,6-O-benzylidene-1-thio- $\beta$ -D-glucopyranoside (**47**)

A 23 mM solution of freshly dried copper(II) trifluoromethanesulfonate in acetonitrile (7 mL) was added to an ice-cold solution of the persilylated thioglycoside **46** (8.18 g, 16 mmol) and benzaldehyde (4.8 mL) in CH<sub>2</sub>Cl<sub>2</sub> (25 mL) at 0 °C. Then, triethylsilylamine (2.81 mL, 17.6 mmol) was added and the reaction mixture was stirred for 3 hours at 0 °C. The mixture was concentrated *in vacuo*. The resulting solid was diluted with CH<sub>2</sub>Cl<sub>2</sub> and benzoic anhydride (9 mL, 48 mmol) was added. The solution was stirred for 24 hours at 40 °C. The mixture was neutralized with a saturated NaHCO<sub>3</sub> solution. Aqueous layer was extracted twice with CH<sub>2</sub>Cl<sub>2</sub>. The combined organic layers were washed with water, dried over MgSO<sub>4</sub>, filtered and evaporated *in vacuo*. Crystallization from EtOAc/hexane gave **47** (5 g) as white crystals.

Chemical formula: C<sub>29</sub>H<sub>30</sub>O<sub>6</sub>S

Molecular weight: 506.62 g/mol

Yield: 62 %

Melting point: 113-115 °C

Literature melting point<sup>154</sup>: 124-125 °C

Optical rotation [ $\alpha$ ]<sub>D</sub> = +13.2 (c = 0.52, CHCl<sub>3</sub>)

Literature optical rotation<sup>154</sup> [ $\alpha$ ]<sub>D</sub> = +26 (c = 0.63, CHCl<sub>3</sub>)

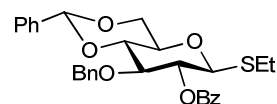



$^1\text{H}$  NMR ( $\text{CDCl}_3$ ):  $\delta$  1.22 (t, 3H,  $J = 7.2$  Hz,  $\text{SCH}_2\text{CH}_3$ ), 2.74 (q, 2H,  $\text{SCH}_2\text{CH}_3$ ), 3.58 (ddd, 1H, H-5), 3.72-3.90 (m, 3H, H-3, H-4, H-6b), 4.38 (dd, 1H,  $J_{5,6a} = 4.9$  Hz,  $J_{6a,6b} = 10.2$  Hz, H-6a), 4.64 (d, 1H,  $J_{1,2} = 11.1$  Hz, H-1), 4.71 (d, 1H,  $J = 12.0$  Hz,  $\frac{1}{2}$   $\text{PhCH}_2$ ), 4.84 (d, 1H,  $J = 12.0$  Hz,  $\frac{1}{2}$   $\text{PhCH}_2$ ), 5.35 (dd, 1H,  $J_{1,2} = 11.1$  Hz,  $J_{2,3} = 8.7$  Hz, H-2), 5.62 (s, 1H,  $\text{PhCH}$ ), 7.10-8.00 (m, 15H, aromatic).

$^{13}\text{C}$  NMR ( $\text{CDCl}_3$ ):  $\delta$  14.8 ( $\text{SCH}_2\text{CH}_3$ ), 24.0 ( $\text{SCH}_2\text{CH}_3$ ), 68.5 (C-6), 70.7 (C-5) 71.8 (C-2) 79.0, 81.6 (C-3, C-4), 74.2 ( $\text{PhCH}_2$ ), 84.3 (C-1), 101.2 ( $\text{PhCH}$ ), 126.0, 127.6, 128.0, 128.1, 128.3, 128.4, 129.3, 129.8, 129.9, 133.2, 137.1, 137.7 (aromatic), 165.2 ( $\text{PhCO}$ ). NMR data are in accordance with literature values.<sup>154</sup>

### Ethyl 2-*O*-benzoyl-3,4-di-*O*-benzyl-1-thio- $\beta$ -D-glucopyranoside (**48**)

1 M  $\text{BH}_3 \cdot \text{THF}$  solution (15 mL) and TMSOTf (0.16 mL) were added to the solution of **47** (3 g, 5.9 mmol) in anhydrous  $\text{CH}_2\text{Cl}_2$  (50 mL). The reaction mixture was stirred at room temperature under an argon atmosphere. After 2 hours triethylamine (1 mL) was added and the solution was concentrated *in vacuo*. Three times methanol (50 mL) was added to the solution and evaporated *in vacuo*. The residue was crystallized from EtOAc/hexane to give **48** as a white solid.

Chemical formula:  $\text{C}_{29}\text{H}_{32}\text{O}_6\text{S}$

Molecular weight: 508.64 g/mol

Yield: 89 %

Melting point: 90-91 °C

Literature melting point<sup>154</sup>: 91-92 °C

Optical rotation  $[\alpha]_{\text{D}} = +54.8$  ( $c = 0.5$ ,  $\text{CHCl}_3$ )

Literature optical rotation<sup>154</sup>  $[\alpha]_{\text{D}} = +33.5$  ( $c = 0.26$ ,  $\text{CHCl}_3$ )

$^1\text{H}$  NMR ( $\text{CDCl}_3$ ):  $\delta$  1.21 (t, 3H,  $J = 7.5$  Hz,  $\text{SCH}_2\text{CH}_3$ ), 2.02 (s, 1H, OH), 2.74 (q, 1H,  $\text{SCH}_2\text{CH}_3$ ), 3.62 (ddd, 1H,  $J_{5,6b} = 2.8$  Hz,  $J_{5,6a} = 4.6$  Hz,  $J_{4,5} = 9.3$  Hz, H-5), 3.67-3.95 (m, 4H, H-3, H-4, H-6a, H-6b), 4.60 (d, 1H,  $J_{1,2} = 10.1$  Hz, H-1), 4.64-4.90 (m, 4H, 2 x  $\text{PhCH}_2$ ), 5.31 (dd, 1H,  $J_{2,3} = 8.9$  Hz, H-2), 7.12-8.08 (m, 15H, aromatic).

$^{13}\text{C}$  NMR ( $\text{CDCl}_3$ ):  $\delta$  14.8 ( $\text{SCH}_2\text{CH}_3$ ), 24.0 ( $\text{SCH}_2\text{CH}_3$ ), 62.0 (C-6), 72.2 (C-2), 75.2 and 75.3 (2 x  $\text{PhCH}_2$ ), 77.6, 79.6 (C-4, C-5), 83.6 (C-3), 84.2 (C-1), 127.6, 127.9, 128.0, 128.2,

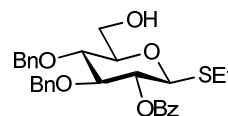

128.3, 128.4, 129.7, 133.2, 137.2, 137.7 (aromatic), 165.4 (PhC(O)). NMR data are in accordance with literature values.<sup>154</sup>

***tert*-Butyl (ethyl 2-*O*-benzoyl-3,4-di-*O*-benzyl-1-thio- $\beta$ -D-glucopyranoside)-uronate (40)**

To the solution of **48** (2.8 g, 5.5 mmol) in anhydrous CH<sub>2</sub>Cl<sub>2</sub> (40 mL) *tert*-butanol (10 mL), acetic anhydride (5 mL) and pyridinium dichromate (4 g, 10 mmol) were added. The reaction mixture was stirred at room temperature under an argon atmosphere. After 2 hours the CH<sub>2</sub>Cl<sub>2</sub> was removed by vacuo and the mixture was transferred onto a column in EtOAc (there was 10 cm EtOAc layer on the top of the silica). After half an hour the mixture was eluted with EtOAc and the fractions were concentrated *in vacuo*. Purification of the residue by column chromatography afforded **40** (2.2 g) as a white solid.

Chemical formula: C<sub>33</sub>H<sub>38</sub>O<sub>7</sub>S

Molecular weight: 578.73 g/mol

Yield: 70 %

Melting point: 107-108 °C

Literature melting point<sup>154</sup>: 109-110 °C

Optical rotation [ $\alpha$ ]<sub>D</sub> = +7.6 (c = 0.5, CHCl<sub>3</sub>)

Literature optical rotation<sup>154</sup> [ $\alpha$ ]<sub>D</sub> = +6.3 (c = 0.41, CHCl<sub>3</sub>)

<sup>1</sup>H NMR (CDCl<sub>3</sub>):  $\delta$  1.22 (t, 3H, *J* = 7.5 Hz, SCH<sub>2</sub>CH<sub>3</sub>), 1.48 (s, 9H, C(CH<sub>3</sub>)<sub>3</sub>), 2.70 (m, 2H, SCH<sub>2</sub>CH<sub>3</sub>), 3.82-4.04 (m, 3H, H-3, H-4, H-5), 4.58 (d, 1H, *J*<sub>1,2</sub> = 10.1 Hz, H-1), 4.62-4.86 (m, 4H, 2 x PhCH<sub>2</sub>), 5.35 (dd, 1H, *J*<sub>2,3</sub> = 8.5 Hz, *J*<sub>1,2</sub> = 10.1 Hz, H-2), 7.12-8.08 (m, 15H, aromatic).

<sup>13</sup>C NMR (CDCl<sub>3</sub>):  $\delta$  14.8 (SCH<sub>2</sub>CH<sub>3</sub>), 23.9 (SCH<sub>2</sub>CH<sub>3</sub>), 28.0 (C(CH<sub>3</sub>)<sub>3</sub>), 72.1 (C-2), 75.0 and 75.1 (2 x PhCH<sub>2</sub>), 79.3, 79.5 (C-4 and C-5), 82.5 (CMe<sub>3</sub>), 83.6 (C-3), 84.6 (C-1), 127.6, 127.7, 127.8, 127.9, 128.1, 128.2, 128.4, 129.9, 133.1, 137.3, 137.7 (aromatic), 165.7 (PhC(O)), 167.0 (C-6). NMR data are in accordance with literature values.<sup>154</sup>

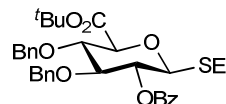

## 6.4. Glycosylation with unprotected acceptors

### General experimental methods

All reactions were performed in oven dried glassware under an argon atmosphere. Solvents and chemicals used were purchased from commercial suppliers. All materials were employed without further purification. Thin layer chromatography (TLC) was carried out on silica gel plates (Silica gel 60, F254, Merck) with detection by UV and visualized by dipping in a 20% solution of sulfuric acid in ethanol followed by heating. Purification by column chromatography was performed using normal-phase silica gel (Silica gel, 230-240 mesh, Merck).  $^1\text{H}$  NMR and  $^{13}\text{C}$  NMR were recorded on a Varian Mercury 300 spectrometer instrument, and the spectra are referenced to solvent residual signals according to literature values.<sup>181</sup> Chemical shifts are reported as  $\delta$  values (ppm) and the coupling constants ( $J$ ) are given in Hz. Assignments of  $^1\text{H}$  and  $^{13}\text{C}$  resonances were based on COSY, HSQC, HMBC experiments. Melting point was measured on a Stuart SMP30 apparatus, optical rotation was measured on a Perkin-Elmer 241 polarimeter. Mass spectrometry was performed on a Waters Aquity UPLC System equipped with PDA and SQD electrospray MS detector.

### 1,2,3,4,6-Penta-*O*-benzoyl- $\alpha,\beta$ -D-glucopyranoside (**49**)

Benzoyl chloride (116 mL, 1 mol) was added dropwise to the mixture of D-(+)-glucose monohydrate (20 g, 0.1 mol) in pyridine (200 mL) at 0 °C. The reaction mixture was stirred overnight at room temperature. Water (70 mL) was added and the mixture was stirred for an additional 30 minutes then evaporated *in vacuo*. The residue was dissolved in  $\text{CH}_2\text{Cl}_2$  and washed with 2 M HCl, with saturated  $\text{NaHCO}_3$  solution and with water. The organic phase was dried over  $\text{MgSO}_4$ , filtered and concentrated *in vacuo*. The residue was purified by recrystallization from EtOAc/hexane to afford **49** (66.5 g) as a white solid.

Chemical formula:  $\text{C}_{41}\text{H}_{32}\text{O}_{11}$

Molecular weight: 700.69 g/mol

Yield: 95 %

Melting point: 122-124 °C

Literature melting point<sup>212</sup>: 172-174 °C

Optical rotation  $[\alpha]_{\text{D}} = +83.84$  ( $c = 1$ ,  $\text{CHCl}_3$ )

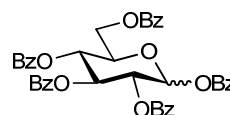

Literature optical rotation of  $\alpha$ -anomer<sup>213</sup>  $[\alpha]_D = +138.4$  ( $c = 1$ ,  $\text{CHCl}_3$ )

Literature optical rotation of  $\beta$ -anomer<sup>214</sup>  $[\alpha]_D = +23.8$  ( $c = 1$ ,  $\text{CHCl}_3$ )

$^1\text{H}$  NMR ( $\text{CDCl}_3$ ):  $\delta$  4.42-4.71 (m, 6H), 5.73 (dd, 1H,  $J_{5,6a} = 3.6$  Hz,  $J_{6a,6b} = 10.2$  Hz, H-6a $^\alpha$ ), 5.90 (m, 4H, H-2 $\alpha/\beta$ , H-4  $\alpha/\beta$ ), 6.09 (t, 2H,  $J = 9.6$  Hz, H-3  $\alpha/\beta$ ), 6.35 (d, 1H,  $J_{1,2} = 9.6$  Hz, H-1 $\beta$ ), 6.87 (d, 1H,  $J_{1,2} = 3.6$  Hz, H-1 $\alpha$ ), 7.26-7.58 (m, 30H, aromatic), 7.87-8.21 (m, 20 H, aromatic).

$^{13}\text{C}$  NMR ( $\text{CDCl}_3$ ):  $\delta$  62.4, 62.6 (C-6 $\alpha$ , C-6 $\beta$ ), 68.7, 68.9 (C-4 $\alpha$ , C-4 $\beta$ ), 70.3, 70.4, 70.5, 70.7 (C-2 $\alpha$ , C-2 $\beta$ , C-3 $\alpha$ , C-3 $\beta$ ), 72.8, 73.1 (C-5 $\alpha$ , C-5 $\beta$ ), 90.0 (C-1 $\alpha$ ), 92.7 (C-1 $\beta$ ), 128.3, 128.4, 128.5, 128.6, 128.7, 128.8, 129.5, 129.7, 129.8, 130.0, 130.1, 130.5, 133.0, 133.1, 133.3, 133.4, 133.5, 133.6, 133.8, 133.9 (aromatic), 164.4, 164.5, 165.1, 165.2, 165.3, 165.6, 165.9, 166.1 (PhCO). NMR data are in accordance with literature values.<sup>215</sup>

### 2,3,4,6-Tetra-*O*-benzoyl- $\alpha$ -D-glucopyranosyl bromide (**50**)

To the solution of **49** (20 g, 28.5 mmol) in  $\text{CH}_2\text{Cl}_2$  (200 mL) 33% HBr in AcOH solution (50 mL) was added. The reaction mixture was stirred at room temperature under argon for 3 hours. Then ice cold water was added. The organic phase was washed with sat.  $\text{NaHCO}_3$  solution twice and with water twice, dried over  $\text{MgSO}_4$ , filtered and evaporated *in vacuo*. The residue was crystallized from  $\text{Et}_2\text{O}$  to give **50** (16.72 g) as a white solid.

Chemical formula:  $\text{C}_{34}\text{H}_{27}\text{BrO}_9$

Molecular weight: 659.48 g/mol

Yield: 89 %

Melting point: 118-120 °C

Literature melting point<sup>216</sup>: 128-130 °C

Optical rotation  $[\alpha]_D = +114.9$  ( $c = 1.5$ ,  $\text{CHCl}_3$ )

Literature optical rotation<sup>216</sup>  $[\alpha]_D = +119.6$  ( $c = 2.5$ ,  $\text{CHCl}_3$ )

$^1\text{H}$  NMR ( $\text{CDCl}_3$ ):  $\delta$  4.52 (dd, 1H,  $J_{5,6a} = 4.5$  Hz,  $J_{6a,6b} = 12.6$  Hz, H-6a), 4.70 (dd, 1H,  $J_{5,6b} = 2.4$  Hz,  $J_{6a,6b} = 12.6$  Hz, H-6b), 4.76 (m, 1H, H-5), 5.35 (dd, 1H,  $J_{1,2} = 3.9$  Hz,  $J_{2,3} = 9.9$  Hz, H-2), 5.85 (t, 1H,  $J = 9.9$  Hz, H-4), 6.29 (t, 1H,  $J = 9.9$  Hz, H-3), 6.88 (d, 1H,  $J_{1,2} = 3.9$  Hz, H-1), 7.26-7.58 (m, 12H, aromatic), 7.87-8.10 (m, 8H, aromatic).

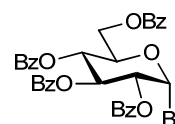

$^{13}\text{C}$  NMR ( $\text{CDCl}_3$ ):  $\delta$  61.9 (C-6), 67.9 (C-4), 70.6 (C-3), 71.4 (C-2), 72.7 (C-5), 86.9 (C-1), 128.3, 128.4, 128.5, 128.7, 129.7, 129.8, 129.9, 130.0, 133.2, 133.3, 133.6, 133.8 (aromatic), 165.0, 165.2, 165.5, 166.0 (4 x PhCO).

### General procedure for diphenylborinic acid catalyzed glycosylation using perbenzoylated glucosyl bromide donor

The mixture of unprotected acceptor (200 mg), 2,3,4,6-tetra-*O*-benzoyl- $\alpha$ -D-glucopyranosyl bromide (**50**) (1.5 equiv. acceptor), 2-aminoethyl diphenylborinate (10 mol% according to the acceptor), in anhydrous  $\text{CH}_2\text{Cl}_2$  /  $\text{CH}_3\text{CN}$  (4:1) (10 mL) was stirred under argon at  $-30\text{ }^\circ\text{C}$  for 30 minutes. Then AgOTf (1.5 equiv. donor) was added and the reaction mixture was stirred under argon at  $-30\text{ }^\circ\text{C}$  for 3 hours. Then the mixture was filtered through Celite, diluted with  $\text{CH}_2\text{Cl}_2$ , washed with saturated  $\text{NaHCO}_3$  solution and with water, dried over  $\text{MgSO}_4$ , filtered and evaporated *in vacuo*. The residue was purified by column chromatography.

### Methyl 2,3,4,6-tetra-*O*-benzoyl- $\beta$ -D-glucopyranosyl-(1 $\rightarrow$ 3)- $\alpha$ -L-rhamnopyranoside (**53**)

Chemical formula:  $\text{C}_{41}\text{H}_{40}\text{O}_{14}$

Molecular weight: 756.75 g/mol

Yield: 42 %

Melting point: - (white foam)

Optical rotation  $[\alpha]_{\text{D}} = -32.6$  ( $c = 0.34$ ,  $\text{CHCl}_3$ )

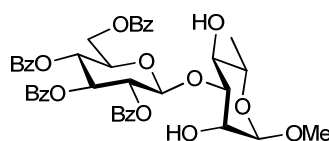

$^1\text{H}$  NMR ( $\text{CDCl}_3$ ):  $\delta$  1.25 (d, 3H,  $J = 5.7$  Hz, H-6), 2.22 (s, 1H, OH), 2.84 (s, 1H, OH), 3.24 (s, 3H,  $\text{OCH}_3$ ), 3.55-3.65 (m, 2H, H-4, H-5), 3.74 (dd, 1H,  $J_{2,3} = 3$  Hz,  $J_{3,4} = 8.7$  Hz, H-3), 4.00 (m, 1H, H-2), 4.21 (m, 1H, H-5'), 4.47 (d, 1H,  $J_{1,2} = 1.5$  Hz, H-1), 4.51 (dd, 1H,  $J_{5',6a'} = 6.9$  Hz,  $J_{6a',6b'} = 12.3$  Hz, H-6a'), 4.72 (dd, 1H,  $J_{5',6a'} = 2.7$  Hz,  $J_{6a',6b'} = 12.3$  Hz, H-6b'), 5.01 (d, 1H,  $J_{1',2'} = 7.8$  Hz, H-1'), 5.55 (dd, 1H,  $J_{1',2'} = 7.8$  Hz,  $J_{2',3'} = 9.9$  Hz, H-2'), 5.64 (t, 1H,  $J = 9.6$  Hz, H-4'), 5.97 (t, 1H,  $J = 9.9$  Hz, H-3'), 7.19-7.59 (m, 12H, aromatic), 7.83-8.09 (m, 8H, aromatic).

$^{13}\text{C}$  NMR ( $\text{CDCl}_3$ ):  $\delta$  17.5 (C-6), 54.6 ( $\text{OCH}_3$ ), 62.6 (C-6'), 67.3 (C-5), 69.3, 69.4 (C-2, C-4'), 70.6 (C-4), 72.3, 72.4 (C-2', C-3'), 72.6 (C-5'), 83.4 (C-3), 100.2 (C-1), 101.7 (C-1'), 128.2, 128.3, 128.3, 128.4, 128.5, 129.0, 129.3, 129.7, 129.8, 129.9, 133.2, 133.3, 133.5, 133.6 (aromatic), 165.2, 165.5, 165.6, 166.1 (4 x PhCO).

MS:  $m/z$  779 [M + Na]

**Phenyl 2,3,4,6-tetra-*O*-benzoyl- $\beta$ -D-glucopyranosyl-(1 $\rightarrow$ 3)-1-thio- $\beta$ -L-fucopyranoside (55)**

Chemical formula: C<sub>46</sub>H<sub>42</sub>O<sub>13</sub>S

Molecular weight: 834.88 g/mol

Yield: 46 %

Melting point: - (white foam)

Optical rotation [ $\alpha$ ]<sub>D</sub> = -15.5 (c = 0.26, CHCl<sub>3</sub>)

<sup>1</sup>H NMR (CDCl<sub>3</sub>):  $\delta$  1.15 (d, 3H,  $J$  = 6.3 Hz, H-6), 2.15 (s, 1H, OH), 3.40-3.54 (m, 4H, H-3, H-4, H-5, OH), 3.74 (t, 1H,  $J$  = 9.3 Hz, H-2), 4.15 (m, 1H, H-5'), 4.33 (dd, 1H,  $J_{5',6a'}$  = 6 Hz,  $J_{6a',6b'}$  = 12.3 Hz, H-6a'), 4.38 (d, 1H,  $J_{1,2}$  = 9.6 Hz, H-1), 4.66 (dd, 1H,  $J_{5',6b'}$  = 2.7 Hz,  $J_{6a',6b'}$  = 12.3 Hz, H-6b'), 4.94 (d, 1H,  $J_{1',2'}$  = 10.5 Hz, H-1'), 5.47 (dd, 1H,  $J_{2',3'}$  = 7.8 Hz,  $J_{1',2'}$  = 10.0 Hz, H-2'), 5.58 (t, 1H,  $J$  = 9.6 Hz, H-4'), 5.88 (t, 1H,  $J$  = 9.9 Hz, H-3'), 7.10-7.45 (m, 15H, aromatic), 7.73-8.03 (m, 10H, aromatic).

<sup>13</sup>C NMR (CDCl<sub>3</sub>):  $\delta$  16.4 (C-6), 62.8 (C-6'), 67.5 (C-2), 69.2 (C-4'), 70.4 (C-4), 72.2, 72.3 (C-2', C-3'), 72.8 (C-5'), 74.2 (C-5), 86.5 (C-3), 87.5 (C-1), 101.4 (C-1'), 127.6, 128.3, 128.4, 128.5, 128.7, 129.7, 129.8, 129.9, 132.5, 133.0, 133.3, 133.4, 133.6 (aromatic), 165.1, 165.4, 165.7, 166.1 (4 x PhCO).

MS:  $m/z$  857 [M + Na]

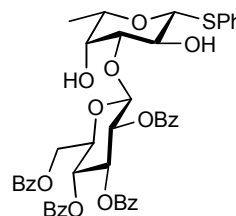

**1,3,4,6-Tetra-*O*-benzoyl- $\alpha$ -D-glucopyranose (56)**

Chemical formula: C<sub>34</sub>H<sub>28</sub>O<sub>10</sub>

Molecular weight: 596.58 g/mol

Yield: 45 %

Melting point: - (syrup)

Optical rotation [ $\alpha$ ]<sub>D</sub> = +149 (c = 1, CHCl<sub>3</sub>)

<sup>1</sup>H NMR (CDCl<sub>3</sub>):  $\delta$  3.13 (s, 1H, OH), 4.29 (m, 1H, H-2), 4.43-4.55 (m, 2H, H-5, H-6a), 4.61 (dd, 1H,  $J_{5,6b}$  = 2.4 Hz,  $J_{6a,6b}$  = 11.7 Hz, H-6b), 5.78 (m, 1H, H-4), 5.94 (t, 1H,  $J$  = 9.9 Hz, H-3), 6.65 (d, 1H,  $J_{1,2}$  = 3.9 Hz, H-1), 7.25-7.56 (m, 12H, aromatic), 7.94-8.19 (m, 8H, aromatic). <sup>1</sup>H-NMR data are in accordance with literature values.<sup>217</sup>

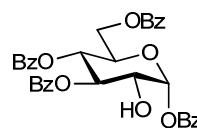

$^{13}\text{C}$  NMR ( $\text{CDCl}_3$ ):  $\delta$  61.6 (C-6), 67.5 (C-4), 69.8 (C-2), 70.7 (C-5), 73.2 (C-3), 91.3 (C-1), 128.4, 128.5, 128.6, 128.7, 129.7, 129.8, 133.2, 133.3, 133.6, 133.9 (aromatic), 165.2, 165.4, 165.7, 166.0 (4 x PhCO).

### General procedure for diphenylborinic acid catalyzed glycosylation using glycosyl acetate as a donor

The mixture of methyl  $\alpha$ -L-rhamnopyranoside (**52**) (100 mg, 0.56 mmol), the glycosyl acetate (1.5 equiv. acceptor), 2-aminoethyl diphenylborinate (12.6 mg, 0.056 mmol) in anhydrous  $\text{CH}_2\text{Cl}_2$  /  $\text{CH}_3\text{CN}$  (4:1) (10 mL) was stirred under argon at room temperature for 30 minutes. Then  $\text{BF}_3 \cdot \text{Et}_2\text{O}$  (1.5 equiv. donor) was added and the reaction mixture was stirred under argon at room temperature for 3 hours. Then the mixture was filtered through Celite, diluted with  $\text{CH}_2\text{Cl}_2$ , washed with saturated  $\text{NaHCO}_3$  solution and with water, dried over  $\text{MgSO}_4$ , filtered and evaporated *in vacuo*. The residue was purified by column chromatography.

### Methyl 3,4-di-O-(3,4,6-tri-O-acetyl-2-deoxy-2-trichloroacetamido- $\beta$ -D-glucopyranosyl)- $\alpha$ -L-rhamnopyranoside (**57**)

Chemical formula:  $\text{C}_{35}\text{H}_{46}\text{Cl}_6\text{O}_{21}\text{N}_2$

Molecular weight: 1043.46 g/mol

Yield: 34 %

Melting point: 85-87  $^\circ\text{C}$

Optical rotation  $[\alpha]_{\text{D}} = +4.5$  ( $c = 0.2$ ,  $\text{CHCl}_3$ )

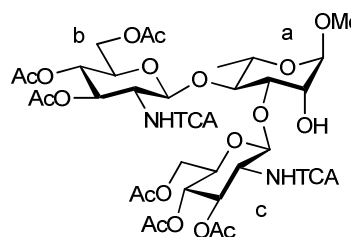

$^1\text{H}$  NMR ( $\text{CDCl}_3$ ):  $\delta$  1.22 (d, 3H,  $J = 4.8$  Hz, H-6<sup>a</sup>), 1.99, 2.00, 2.02, 2.03, 2.05, 2.10 (6 x  $\text{CH}_3\text{CO}$ ), 2.61 (s, 1H, OH), 3.29 (s, 3H,  $\text{OCH}_3$ ), 3.49 (m, 2H, H-5<sup>a</sup>, H-3<sup>a</sup>), 3.71 (m, 2H, H-4<sup>a</sup>, H-5<sup>c</sup>), 3.82 (m, 1H, H-5<sup>b</sup>), 4.01-4.16 (m, 5H, H-2<sup>a</sup>, H-2<sup>b</sup>, H-6b<sup>b</sup>, H-2<sup>c</sup>, H-6b<sup>c</sup>), 4.23 (dd, 1H,  $J_{5^c,6a^c} = 3.8$  Hz,  $J_{6a^c,6b^c} = 12.3$  Hz, H-6a<sup>c</sup>), 4.41 (dd, 1H,  $J_{5^b,6a^b} = 5.4$  Hz,  $J_{6a^b,6b^b} = 12.6$  Hz, H-6a<sup>b</sup>), 4.64 (d, 1H,  $J_{1^a,2^a} = 1.5$  Hz, H-1<sup>a</sup>), 4.83 (d, 1H,  $J_{1^b,2^b} = 8.4$  Hz, H-1<sup>b</sup>), 5.02-5.14 (m, 3H, H-4<sup>b</sup>, H-1<sup>c</sup>, H-4<sup>c</sup>), 5.30-5.37 (m, 2H, H-3<sup>b</sup>, H-3<sup>c</sup>).

$^{13}\text{C}$  NMR ( $\text{CDCl}_3$ ):  $\delta$  17.5 (C-6<sup>a</sup>), 20.4, 2 x 20.5, 2 x 20.6, 20.7 (6 x  $\text{CH}_3\text{CO}$ ), 54.4 ( $\text{OCH}_3$ ), 55.5, 56.0 (C-2<sup>b</sup>, C-2<sup>c</sup>), 61.8, 62.0 (C-6<sup>b</sup>, C-6<sup>c</sup>), 68.0, 68.1 (C-4<sup>b</sup>, C-4<sup>c</sup>), 68.6 (C-5<sup>a</sup>), 70.8 (C-2<sup>a</sup>), 71.6, 71.7 (C-5<sup>b</sup>, C-5<sup>c</sup>), 71.8, 72.2 (C-3<sup>b</sup>, C-3<sup>c</sup>), 76.0 (C-3<sup>a</sup>), 83.2 (C-4<sup>a</sup>), 92.1, 92.3 (2 x

CCl<sub>3</sub>), 99.9 (C-1<sup>a</sup>), 100.2 (C-1<sup>c</sup>), 102.8 (C-1<sup>b</sup>), 162.2, 162.6 (2 x NHCO), 168.3, 170.6, 170.8 (6 x CH<sub>3</sub>CO).

MS: *m/z* 1043 [M]

### Methyl 3,4-di-*O*-(2,3,4,6-tetra-*O*-acetyl-β-*D*-glucopyranosyl)-α-*L*-rhamnopyranoside (58)

Chemical formula: C<sub>30</sub>H<sub>50</sub>O<sub>23</sub>

Molecular weight: 838.76 g/mol

Yield: 29 %

Optical rotation [α]<sub>D</sub> = -38.7 (c = 0.9, CHCl<sub>3</sub>)

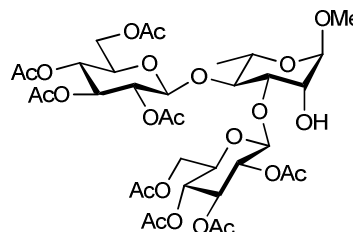

<sup>1</sup>H NMR (CDCl<sub>3</sub>): δ 1.26 (d, 3H, *J* = 6.0 Hz, H-6<sup>a</sup>), 1.99, 2.00, 2.01, 2.02, 2.03, 2.04, 2.06, 2.07 (8 x CH<sub>3</sub>CO), 2.34 (s, 1H, OH), 3.32 (s, 3H, OCH<sub>3</sub>), 3.53 (m, 1H, H-5<sup>a</sup>), 3.63-3.75 (m, 4H, H-2<sup>a</sup>, H-4<sup>a</sup>, H-5<sup>b</sup>, H-5<sup>c</sup>), 3.86 (dd, 1H, *J*<sub>2<sup>a</sup>,3<sup>a</sup></sub> = 1.8 Hz, *J*<sub>3<sup>a</sup>,4<sup>a</sup></sub> = 3.0 Hz, H-3<sup>a</sup>), 4.15-4.33 (m, 4H, H-6a<sup>b</sup>, H-6b<sup>b</sup>, H-6a<sup>c</sup>, H-6b<sup>c</sup>), 4.61 (d, 1H, *J*<sub>1<sup>b</sup>,2<sup>b</sup></sub> = 8.1 Hz, H-1<sup>b</sup>), 4.68 (d, 1H, *J*<sub>1<sup>a</sup>,2<sup>a</sup></sub> = 1.8 Hz, H-1<sup>a</sup>), 4.71 (d, 1H, *J*<sub>1<sup>c</sup>,2<sup>c</sup></sub> = 8.4 Hz, H-1<sup>c</sup>), 4.92-5.28 (m, 6H, H-2<sup>b</sup>, H-2<sup>c</sup>, H-3<sup>b</sup>, H-3<sup>c</sup>, H-4<sup>b</sup>, H-4<sup>c</sup>).

<sup>13</sup>C NMR (CDCl<sub>3</sub>): δ 17.5 (C-6<sup>a</sup>), 2 x 20.5, 3 x 20.6, 2 x 20.7, 20.8 (8 x CH<sub>3</sub>CO), 54.7 (OCH<sub>3</sub>), 61.2, 61.8 (C-6<sup>b</sup>, C-6<sup>c</sup>), 68.0, 68.7 (C-4<sup>b</sup>, C-4<sup>c</sup>), 70.8, 71.1, 71.2, 71.7, 72.0, 72.4, 72.5, 72.6 (C-2<sup>a</sup>, C-2<sup>b</sup>, C-2<sup>c</sup>, C-3<sup>b</sup>, C-3<sup>c</sup>, C-5<sup>a</sup>, C-5<sup>b</sup>, C-5<sup>c</sup>), 78.3 (C-3<sup>a</sup>), 82.8 (C-4<sup>a</sup>), 100.2 (C-1<sup>a</sup>), 101.7 (C-1<sup>c</sup>), 103.0 (C-1<sup>b</sup>), 169.3, 169.4, 169.6, 169.7, 170.1, 170.2, 170.3, 170.6 (8 x CH<sub>3</sub>CO).

MS: *m/z* 861 [M + Na]

### General procedure for boronate-mediated glycosylation using perbenzoylated glucosyl bromide donor

A mixture of unprotected phenyl 1-thio-hexopyranoside (acceptor, 200 mg), phenylboronic acid (1.2 equiv. acceptor) and 4 Å freshly activated molecular sieves in anhydrous CH<sub>2</sub>Cl<sub>2</sub> (3 mL) was stirred at room temperature for 8 h. 2,3,4,6-Tetra-*O*-benzoyl-α-*D*-glucopyranosyl bromide (**50**) (1.5 equiv. acceptor) in CH<sub>2</sub>Cl<sub>2</sub> (7 mL) was added and the mixture was stirred for 30 minutes, cooled to -30 °C, then silver triflate (1.5 eq. donor) and *sym*-collidine (1.5 eq. donor) were added. The reaction mixture was stirred under an argon atmosphere for 3 h at -30 °C, then slowly warmed to room temperature. The mixture was filtered through Celite, diluted



with CH<sub>2</sub>Cl<sub>2</sub>, washed with 2 M HCl, saturated NaHCO<sub>3</sub> solution and water, dried over MgSO<sub>4</sub>, filtered and evaporated *in vacuo*. The residue was purified by column chromatography.

**Phenyl 2,3,4,6-tetra-*O*-benzoyl-β-D-glucopyranosyl-(1→2)-1-thio-β-L-fucopyranoside (59)**

Chemical formula: C<sub>46</sub>H<sub>42</sub>O<sub>13</sub>S

Molecular weight: 834.88 g/mol

Yield: 66%

Melting point: - (white foam)

Optical rotation [α]<sub>D</sub> = -26.9 (c = 0.8, CHCl<sub>3</sub>)

<sup>1</sup>H NMR (CDCl<sub>3</sub>): δ 1.13 (d, 3H, *J* = 6.6 Hz, H-6), 2.23 (s, 1H, OH), 3.36-3.54 (m, 4H, H-3, H-4, H-5, OH), 3.74 (m, 1H, H-2), 4.16 (m, 1H, H-5'), 4.33 (dd, 1H, *J*<sub>5',6a'</sub> = 6 Hz, *J*<sub>6a',6b'</sub> = 12.3 Hz, H-6a'), 4.38 (d, 1H, *J*<sub>1,2</sub> = 9.6 Hz, H-1), 4.66 (dd, 1H, *J*<sub>5',6b'</sub> = 3.0 Hz, *J*<sub>6a',6b'</sub> = 12.3 Hz, H-6b'), 4.94 (d, 1H, *J*<sub>1',2'</sub> = 7.8 Hz, H-1'), 5.47 (dd, 1H, *J*<sub>1',2'</sub> = 7.8 Hz, *J*<sub>2',3'</sub> = 9.6 Hz, H-2'), 5.58 (t, 1H, *J* = 9.9 Hz, H-4'), 5.88 (t, 1H, *J* = 9.6 Hz, H-3'), 7.08-7.47 (m, 15H, aromatic), 7.73-8.02 (m, 10H, aromatic)

<sup>13</sup>C NMR (CDCl<sub>3</sub>): δ 16.4 (C-6), 62.8 (C-6'), 67.5 (C-5), 69.2 (C-3), 70.3 (C-4'), 71.2 (C-4), 72.3 (C-2'), 72.7 (C-3'), 74.1 (C-5'), 86.4 (C-2), 94.7 (C-1), 101.3 (C-1'), 127.5, 128.1, 128.2, 128.4, 128.7, 128.9, 129.2, 129.6, 129.7, 129.8, 132.3, 133.0, 133.2, 133.3, 133.5 (aromatic), 165.0, 165.4, 165.6, 166.0 (4 x PhCO)

MS: *m/z* 857 [M + Na]

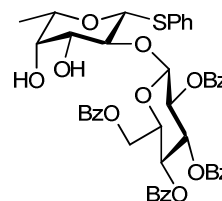

**Phenyl 2,3,4,6-tetra-*O*-benzoyl-β-D-glucopyranosyl-(1→3)-1-thio-β-D-galactopyranoside (61)**

Chemical formula: C<sub>46</sub>H<sub>42</sub>O<sub>14</sub>S

Molecular weight: 850.88 g/mol

Yield: 74%

Melting point: 86-88 °C

Optical rotation [α]<sub>D</sub> = +13 (c = 1, CHCl<sub>3</sub>)

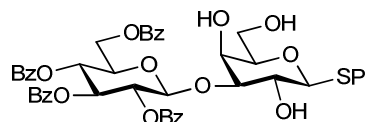

$^1\text{H}$  NMR ( $\text{CDCl}_3$ ):  $\delta$  2.27 (s, 1H, OH), 2.37 (s, 1H, OH), 2.70 (s, 1H, OH), 3.37 (m, 1H, H-5), 3.49-3.58 (m, 2H, H-3, H-6a), 3.64-.79 (m, 2H, H-2, H-6b), 3.98 (d, 1H,  $J = 2.4$  Hz, H-4), 4.10 (m, 1H, H-5'), 4.37 (d, 1H,  $J_{1,2} = 9.6$  Hz, H-1), 4.41 (dd, 1H,  $J_{5',6a'} = 6.0$  Hz,  $J_{6a',6b'} = 12.0$  Hz, H-6a'), 4.60 (dd, 1H,  $J_{5',6b'} = 2.7$  Hz,  $J_{6a',6b'} = 12.0$  Hz, H-6b'), 5.06 (d, 1H,  $J_{1',2'} = 7.8$  Hz, H-1'), 5.43 (dd, 1H,  $J_{1',2b'} = 7.8$  Hz,  $J_{2',3'} = 9.9$  Hz, H-2'), 5.56 (t, 1H,  $J = 9.9$  Hz, H-4'), 5.87 (t, 1H,  $J = 9.9$  Hz, H-3'), 7.08-7.48 (m, 15H, aromatic), 7.74-7.97 (m, 10H, aromatic).

$^{13}\text{C}$  NMR ( $\text{CDCl}_3$ ):  $\delta$  62.3 (C-6), 62.7 (C-6'), 68.2 (C-2), 68.5 (C-4), 69.3 (C-4'), 72.1 (C-2'), 72.3 (C-3'), 72.5 (C-5'), 78.0 (C-5), 83.6 (C-3), 88.1 (C-1), 101.5 (C-1'), 127.8, 128.2, 128.3, 128.4, 128.5, 128.6, 128.9, 129.0, 129.2, 129.7, 129.8, 132.1, 132.3, 133.4, 133.6 (aromatic), 165.2, 165.5, 165.7, 166.1 (4 x PhCO).

MS:  $m/z$  873 [M + Na]

### Phenyl 2,3,4,6-tetra-*O*-benzoyl- $\beta$ -D-glucopyranosyl-(1 $\rightarrow$ 6)-1-thio- $\beta$ -D-galactopyranoside (62)

The mixture of phenyl 1-thio- $\beta$ -D-galactopyranoside (**51**) (1 g, 3.67 mmol), dibutyltin oxide (0.92 g, 3.67 mmol) in methanol (20 mL) was refluxed for 3 hours under an argon atmosphere. The mixture was evaporated *in vacuo* and the residue was dissolved in dry  $\text{CH}_2\text{Cl}_2$  (40 mL) and 2,3,4,6-tetra-*O*-benzoyl- $\alpha$ -D-glucopyranosyl bromide (**50**) (3.63 g, 5.5 mmol) was added. The mixture was stirred at  $-30$  °C for 30 minutes under an argon atmosphere, and then AgOTf (2.12 g, 8.25 mmol) was added. The reaction mixture was stirred at  $-30$  °C for overnight. The mixture was filtered through Celite, diluted with  $\text{CH}_2\text{Cl}_2$ , washed with 2 M HCl, saturated  $\text{NaHCO}_3$  solution and water, dried over  $\text{MgSO}_4$ , filtered and concentrated *in vacuo*. The residue was purified by column chromatography to afford **62** as a white solid.

Chemical formula:  $\text{C}_{46}\text{H}_{42}\text{O}_{14}\text{S}$

Molecular weight: 850.88 g/mol

Yield: 75%

Melting point: 94-96 °C

Optical rotation  $[\alpha]_{\text{D}} = +8.9$  ( $c = 1$ ,  $\text{CHCl}_3$ )

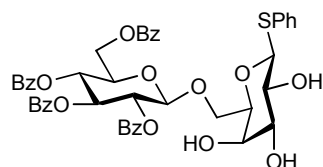

$^1\text{H}$  NMR ( $\text{CDCl}_3$ ):  $\delta$  2.09 (s, 1H, OH), 3.12 (s, 1H, OH), 2.70 (s, 1H, OH), 3.23 (m, 1H, H-6b), 3.38 (d, 1H,  $J = 5.7$  Hz, H-3), 3.50 (t, 1H,  $J = 6.3$  Hz, H-5), 3.60 (t, 1H,  $J = 9$  Hz, H-2), 3.85-3.97 (m, 2H, H-4, H-6a), 3.99-4.04 (m, 1H, H-5'), 4.30 (dd, 1H,  $J_{5',6a'} = 4.5$  Hz,  $J_{6a',6b'} = 12.0$  Hz, H-6a'), 4.35 (d, 1H,  $J_{1,2} = 9.9$  Hz, H-1), 4.41 (dd, 1H,  $J_{5',6b'} = 2.7$  Hz,  $J_{6a',6b'} = 12.0$  Hz, H-6b'), 4.85 (d, 1H,  $J_{1',2'} = 8.1$  Hz, H-1'), 5.42 (dd, 1H,  $J_{1',2b'} = 8.1$  Hz,  $J_{2',3'} = 9.3$  Hz, H-2'), 5.61 (t, 1H,  $J = 9.6$  Hz, H-4'), 5.79 (t, 1H,  $J = 9.6$  Hz, H-3'), 7.16-7.45 (m, 15H, aromatic), 7.73-7.98 (m, 10H, aromatic)

$^{13}\text{C}$  NMR ( $\text{CDCl}_3$ ):  $\delta$  62.5 (C-6), 68.0 (C-6'), 68.2 (C-4), 69.3 (C-2), 69.9 (C-4'), 71.7 (C-2'), 72.3 (C-5'), 72.7 (C-3'), 74.3 (C-3), 77.3 (C-5), 88.5 (C-1), 101.0 (C-1'), 127.8, 128.2, 128.3, 128.4, 128.5, 128.6, 129.0, 129.2, 129.7, 129.8, 132.0, 133.2, 133.3, 133.4 (aromatic), 165.1, 165.2, 165.7, 166.3 (4 x PhCO)

MS:  $m/z$  873 [M + Na]

## References

- (1) Barbier, P. *C.R. Acad. Sci* **1899**, *128*, 110-111.
- (2) Grignard, V. *C. R. Acad. Sci.* **1900**, *130*, 1322-1324.
- (3) Silverman, G. S.; Rakita, P. E. *Handbook of Grignard Reagents*; Marcel Dekker, 1996.
- (4) Hing, L. Y. *Synthesis* **1981**, 585-604.
- (5) Ashby, C. E. *Quarterly Reviews* **1967**, *21*, 259-285.
- (6) Guggenberger, L. J.; Rundle, R. E. *J. Am. Chem. Soc.* **1964**, *86*, 5344-5345.
- (7) Guggenberger, L. J.; Rundle, R. E. *J. Am. Chem. Soc.* **1968**, *90*, 5375-5378.
- (8) Stucky, G. D.; Rundle, R. E. *J. Am. Chem. Soc.* **1964**, *86*, 4825-4830.
- (9) Vallino, M. *J. Organomet. Chem.* **1969**, *20*, 1-10.
- (10) Schlenk, W.; Schlenk, W. *Ber. Deutsch. Chem. Ges.* **1929**, *62*, 920-924.
- (11) Ashby, E. C.; Parris, G.; Walker, F. *Chem. Commun.* **1969**, 1464.
- (12) Parris, G.; Ashby, E. C. *J. Am. Chem. Soc.* **1971**, *93*, 1206-1213.
- (13) Andersen, R. A.; Wilkinson, G.; Lappert, M. F.; Earce, R. *Inorg. Synth.* **1979**, *19*, 262.
- (14) Ashby, E. C. *Bull. Soc. Chim. Fr.* **1972**, 2133-2142.
- (15) Richey Jr., H. G. *Grignard Reagents - New Developments*; Wiley, 2000.
- (16) Li, C.-J. *Chem. Rev.* **2005**, *105*, 3095-3165.
- (17) Petrier, C.; Luche, J. L. *J. Org. Chem.* **1985**, 910-912.
- (18) Wada, M.; Ohki, H.; Akiba, K. *Bull. Chem. Soc. Jpn.* **1990**, *63*, 1738-1747.
- (19) Li, C.-J. Meng, Y. Yi, X.-H. Ma, J.; Chan, T.-H. *J. Org. Chem* **1998**, *63*, 7498-7504.
- (20) Li, L. *Tetrahedron Lett.* **2000**, *41*, 5009-5012.
- (21) Kim, E.; Gordon, D. M.; Schmid, W.; Whitesides, G. M. *J. Org. Chem.* **1993**, *58*, 5500-5507.

- (22) Zhang, W.-C.; Li, C.-J. *J. Org. Chem.* **1999**, *64*, 3230-3236.
- (23) Meites, L.; Zuman, P. *CRC Handbook Series in Organic Electrochemistry, Vol. 1-4*, CRC Press, 2007
- (24) Dam, J. H.; Fristrup, P.; Madsen, R. *J. Org. Chem.* **2008**, *73*, 3228-3235.
- (25) Chung, L. W.; Chan, T. H.; Wu, Y.-D. *Organometallics* **2005**, *24*, 1598-1607.
- (26) Holm, T. *J. Org. Chem.* **2000**, *65*, 1188-1192.
- (27) Benkeser, R. A.; Young, W. G.; Broxterman, W. E.; Jones, Jr., D. A.; Piaseczynski, S. *J. Am. Chem. Soc.* **1969**, *91*, 132-137.
- (28) Killinger, A. T.; Boughton, N. A.; Runge, T. A.; Wolinsky, J. *J. Org. Chem.* **1977**, *124*, 131-134.
- (29) Nokami, J.; Otera, J.; Sudo, T.; Okawara, R. *Organometallics* **1983**, *2*, 191-193.
- (30) Li, C. J.; Chan, T. H. *Tetrahedron Lett.* **1991**, 7017-7020.
- (31) Francis, A. W. *J. Am. Chem. Soc.* **1926**, *48*, 655-672.
- (32) Holm, T. *Acta Chem. Scand.* **1983**, *37B*, 567-584.
- (33) Holm, T. *Tetrahedron Lett.* **1966**, *7*, 3329-3336.
- (34) Tolgyesi, W. S. *Can. J. Chem.* **1965**, *43*, 343-355.
- (35) Hammett, P. *J. Am. Chem. Soc.* **1937**, *59*, 96-103.
- (36) Cupido, T.; Tulla-Puche, J.; Spengler, J.; Albericio, F. *Curr. Opin. Drug Discovery Dev.* **2007**, *10*, 768-783.
- (37) Carey, J. S.; Laffan, D.; Thomson, C.; Williams, M. T. *Org. Biomol. Chem.* **2006**, *4*, 2337-2347.
- (38) Okada, M. *Prog. Polym. Sci.* **2002**, *27*, 87-133.
- (39) Montalbetti, C. A. G. N.; Falque, V.; Park, M.; Ox, A. *Tetrahedron* **2005**, *61*, 10827-10852.
- (40) Krow, G. R. *Tetrahedron* **1981**, *37*, 1283-1370.
- (41) Eck, J. C.; Marvel, C. S. *Org. Synth.* **1939**, *19*, 20-22.
- (42) Saxon, E. *Science* **2000**, *287*, 2007-2010.

- (43) Köhn, M.; Breinbauer, R. *Angew. Chem. Int. Ed.* **2004**, *43*, 3106-3116.
- (44) Polshettiwar, V.; Varma, R. S. *Tetrahedron Lett.* **2008**, *49*, 2661-2664.
- (45) Bode, J. W.; Fox, R. M.; Baucom, K. D. *Angew. Chem. Int. Ed.* **2006**, *45*, 1248-1252.
- (46) Smith, B. T.; Wendt, J. A.; Aubé, J. *Org. Lett.* **2002**, *4*, 2577-2579.
- (47) Kolakowski, R. V.; Shangguan, N.; Sauers, R. R.; Williams, L. J. *J. Am. Chem. Soc.* **2006**, *128*, 5695-5702.
- (48) Murahashi, S.-I.; Naota, T.; Saito, E. *J. Am. Chem. Soc.* **1986**, *108*, 7846-7847.
- (49) Kim, J. W.; Yamaguchi, K.; Mizuno, N. *Angew. Chem. Int. Ed.* **2008**, *47*, 9249-9251.
- (50) Gunanathan, C.; Ben-Davis, Y.; Milstein, D. *Science* **2007**, *317*, 790-792.
- (51) Watson, A. J.; Maxwell, A. C.; Williams, J. M. J. *Org. Lett.* **2009**, *11*, 2667-2670.
- (52) Nordstrøm, L. U.; Vogt, H.; Madsen, R. *J. Am. Chem. Soc.* **2008**, *130*, 17672-17673.
- (53) Ghosh, S. C.; Muthaiah, S.; Zhang, Y.; Xu, X.; Hong, S. H. *Adv. Synth. Catal.* **2009**, *351*, 2643-2649.
- (54) Muthaiah, S.; Ghosh, S. C.; Jee, J.-E.; Chen, C.; Zhang, J.; Hong, S. H. *J. Org. Chem.* **2010**, *75*, 3002-3006.
- (55) Prades, A.; Peris, E.; Albrecht, M. *Organometallics* **2011**, *30*, 1162-1167.
- (56) Nova, A.; Balcells, D.; Schley, N. D.; Dobereiner, G. E.; Crabtree, R. H.; Eisenstein, O. *Organometallics* **2010**, *29*, 6548-6558.
- (57) Fujita, K.-I.; Takahashi, Y.; Owaki, M.; Yamamoto, K.; Yamaguchi, R. *Org. Lett.* **2004**, 2785-2788.
- (58) Zweifel, T.; Naubron, J.-V.; Grützmacher, H. *Angew. Chem. Int. Ed.* **2009**, *48*, 559-563.
- (59) Shimizu, K.-I.; Ohshima, K.; Satsuma, A. *Chem. Eur. J.* **2009**, *15*, 9977-9780.
- (60) Burling, S.; Kociok-Köhn, G.; Mahon, M. F.; Whittlesey, M. K.; Williams, J. M. J. *Organometallics* **2005**, *24*, 5868-5878.
- (61) Wang, H. M. J.; Lin, I. J. B. *Organometallics* **1998**, *17*, 972-975.
- (62) Arduengo, A. J. *Acc. Chem. Res.* **1999**, *32*, 913-921.

- (63) Dragutan, V.; Dragutan, I.; Delaude, L.; Demonceau, A. *Coord. Chem. Rev.* **2007**, *251*, 765-794.
- (64) Delaude, L.; Delfosse, S.; Richel, A.; Demonceau, A.; Noels, A. F. *Chem. Commun.* **2003**, 1526-1527.
- (65) Jafarpour, L.; Huang, J.; Stevens, E. D.; Nolan, S. P. *Organometallics* **1999**, *18*, 3760-3763.
- (66) Kücükbay, H.; Cetinkaya, B.; Guesmi, S.; Dixneuf, P. H. *Organometallics* **1996**, *15*, 2434-2439.
- (67) Herrmann, W. A.; Köcher, C.; Gooßen, L. J.; Artus, G. R. J. *Chem. Eur. J.* **1996**, *2*, 1627-1636.
- (68) Csabai, P.; Joó, F. *Organometallics* **2004**, *23*, 5640-5643.
- (69) Zhou, J.; Fu, G. C. *J. Am. Chem. Soc.* **2003**, *125*, 12527-12530.
- (70) Mistryukov, E. A. *Mendeleev Commun.* **2006**, *16*, 258-259.
- (71) Scholl, M.; Ding, S.; Lee, C. W.; Grubbs, R. H. *Org. Lett.* **1999**, *1*, 953-956.
- (72) Louie, J.; Bielawski, C. W.; Grubbs, R. H. *J. Am. Chem. Soc.* **2001**, *123*, 11312-11313.
- (73) Alcaide, B.; Almendros, P.; Luna, A. *Chem. Rev.* **2009**, *109*, 3817-3858.
- (74) Schwab, P.; Grubbs, R. H.; Ziller, J. W. *J. Am. Chem. Soc.* **1996**, *118*, 100-110.
- (75) Stewart, I. C.; Ung, T.; Pletnev, A. A.; Berlin, J. M.; Grubbs, R. H.; Schrodi, Y. *Org. Lett.* **2007**, *9*, 1589-1592.
- (76) Grubbs, R. H. *Handbook of Metathesis Vol. 1-3*, Wiley, 2004.
- (77) Chatterjee, A. K.; Choi, T.-L.; Sanders, D. P.; Grubbs, R. H. *J. Am. Chem. Soc.* **2003**, *125*, 11360-11370.
- (78) Garber, S. B.; Kingsbury, J. S.; Gray, B. L.; Hoveyda, A. H. *J. Am. Chem. Soc.* **2000**, *122*, 8168-8179.
- (79) Zhang, Y.; Chen, C.; Ghosh, S. C.; Li, Y.; Hong, S. H. *Organometallics* **2010**, *29*, 1374-1378.
- (80) Martín-Matute, B.; Aberg, J. B.; Edin, M.; Bäckvall, J.-E. *Chem. Eur. J.* **2007**, *13*, 6063-6072.

- (81) Aranyos, A.; Csjernyik, G.; Szabo, K. J.; Bäckvall, J.-E. *Chem. Commun.* **1999**, 2, 351-352.
- (82) Chatwin, S. L.; Davidson, M. G.; Doherty, C.; Donald, S. M.; Jazzar, R. F. R.; Macgregor, S. A.; McIntyre, G. J.; Mahon, M. F.; Whittlesey, M. K. *Organometallics* **2006**, 25, 99-110.
- (83) Gubler, D. J. *Clin. Microbiol. Rev.* **1998**, 11, 480-496.
- (84) Monath, T. P. *Proc. Natl. Acad. Sci. USA* **1994**, 91, 2395-2400.
- (85) WHO | Dengue. <http://www.who.int/topics/dengue/en/>.
- (86) Halstead, S. B. *Lancet* **2007**, 370, 1644-1652.
- (87) McBride, W. J.; Bielefeldt-Ohmann, H. *Microbes Infect.* **2000**, 2, 1041-1050.
- (88) Whitehead, S. S.; Blaney, J. E.; Durbin, A. P.; Murphy, B. R. *Nat. Rev. Microbiol.* **2007**, 5, 518-528.
- (89) da Fonseca, B. A.; Fonseca, S. N. *Curr. Opin. Pediatr.* **2002**, 14, 67-71.
- (90) Holmes, E. C.; Twiddy, S. S. *Infect. Genet. Evol.* **2003**, 3, 19-28.
- (91) World Health Organisation *Fact Sheet: Dengue and Dengue Haemorrhagic Fever*, WHO, Geneva, **2008**.
- (92) Kuno, G.; Chang, G. J.; Tsuchiya, K. R.; Karabatsos, N.; Cropp, C. B. *J. Virol.* **1998**, 72, 73-83.
- (93) Chambers, T. J.; Liang, Y.; Droll, D. A.; Schlesinger, J. J.; Davidson, A. D.; Wright, P. J.; Jiang, X. *J. Virol.* **2003**, 77, 3655-3668.
- (94) Green, S.; Rothman, A. *Curr. Opin. Infect. Dis.* **2006**, 19, 429-436.
- (95) Gubler, D. J. *Novartis Found. Symp.* **2006**, 277, 3-16.
- (96) Schneider-Schaulies, J. *J. Gen. Virol.* **2000**, 81, 1413-1429.
- (97) Chen, Y.; Maguire, T.; Marks, R. M. *J. Virol.* **1996**, 70, 8765-8772.
- (98) Modis, Y.; Ogata, S.; Clements, D.; Harrison, S. C. *Nature* **2004**, 427, 313-319.
- (99) Modis, Y.; Ogata, S.; Clements, D.; Harrison, S. C. *Proc. Natl. Acad. Sci. USA* **2003**, 100, 6986-6991.
- (100) Crill, W. D.; Roehrig, J. T. *J. Virol.* **2001**, 75, 7769-7773.



- (101) Chen, Y.; Maguire, T.; Hileman, R. E.; Fromm, J. R.; Esko, J. D.; Linhardt, R. J.; Marks, R. M. *Nat. Med.* **1997**, *3*, 866-871.
- (102) Hilgard, P.; Stockert, R. *Hepatology* **2000**, *32*, 1069-1077.
- (103) Germe, R.; Crance, J.-M.; Garin, D.; Guimet, J.; Lortat-Jacob, H.; Ruigrok, R. W. H.; Zarski, J.-P.; Drouet, E. *Virology* **2002**, *292*, 162-168.
- (104) Lin, Y.-L.; Lei, H.-Y.; Lin, Y.-S.; Yeh, T.-M.; Chen, S.-H.; Liu, H.-S. *Antiviral Res.* **2002**, *56*, 93-96.
- (105) Kroschewski, H.; Allison, S. L.; Heinz, F. X.; Mandl, C. W. *Virology* **2003**, *308*, 92-100.
- (106) Casu, B. *Adv. Carbohydr. Chem. Biochem.* **1985**, *43*, 51-134.
- (107) Gallagher, J. T.; Turnbull, J. E.; Lyon, M. *Adv. Exp. Med. Biol.* **1992**, *313*, 49-57.
- (108) Griffin, C. C.; Linhardt, R. J.; Van Gorp, C. L.; Toida, T.; Hileman, R. E.; Schubert, R. L.; Brown, S. E. *Carbohydr. Res.* **1995**, *276*, 183-197.
- (109) Clyde, K.; Kyle, J. L.; Harris, E. *J. Virol.* **2006**, *80*, 11418-11431.
- (110) Aoki, C.; Hidari, K. I. P. J.; Itonori, S.; Yamada, A.; Takahashi, N.; Kasama, T.; Hasebe, F.; Islam, M. A.; Hatano, K.; Matsuoka, K.; Taki, T.; Guo, C.-T.; Takahashi, T.; Sakano, Y.; Suzuki, T.; Miyamoto, D.; Sugita, M.; Terunuma, D.; Morita, K.; Suzuki, Y. *J. Biochem.* **2006**, *139*, 607-614.
- (111) Kunz, C.; Rudloff, S.; Baier, W.; Klein, N.; Strobel, S. *Annu. Rev. Nutr.* **2000**, *20*, 699-722.
- (112) Newburg, D. S. *J. Anim. Sci.* **2009**, *87*, 26-34.
- (113) Idänpään-Heikkilä, I.; Simon, P. M.; Zopf, D.; Vullo, T.; Cahill, P.; Sokol, K.; Tuomanen, E. *J. Inf. Dis.* **1997**, *176*, 704-712.
- (114) Schwarting, G.; Marcus, D. M. *J. Immunol.* **1977**, *118*, 1415-1419.
- (115) Stults, C. L.; Sweely, C. C.; Macher, B. A. *Methods Enzymol.* **1989**, *179*, 167-214.
- (116) Wichit, S.; Jittmittraphap, A.; Hidari, K. I. P. J.; Thaisomboonsuk, B.; Petmitr, S.; Ubol, S.; Aoki, C.; Itonori, S.; Morita, K.; Suzuki, T.; Suzuki, Y.; Jampangern, W. *Microbiol. Immunol* **2011**, *55*, 135-140.
- (117) Levy, D. E.; Fügedi, P. *The Organic Chemistry of Sugars*, CRC Press, 2005.
- (118) Paulsen, H. *Angew. Chem. Int. Ed.* **1982**, *21*, 155-173.

- (119) Fischer, E.; Delbrück, K. *Ber. Deutsch. Chem. Ges.* **1909**, *42*, 1476-1482.
- (120) Ferrier, R. J.; Furneaux, R. H. *Carbohydr. Res.* **1976**, *52*, 63-68.
- (121) Schmidt, R. R.; Stumpp, M. *Liebigs. Ann. Chem.* **1983**, 1249-1256.
- (122) Gordon, D. M.; Danishefsky, S. J. *Carbohydr. Res.* **1990**, *206*, 361-366.
- (123) Stewart, A. O.; Williams, R. M. *J. Am. Chem. Soc.* **1985**, *107*, 4289-4296.
- (124) Ferrier, R. J.; Hay, R. W.; Vethaviasar, N. *Carbohydr. Res.* **1973**, *27*, 55-61.
- (125) Lönn, H. *Carbohydr. Res.* **1985**, *139*, 105-113.
- (126) Fügedi, P.; Garegg, P. J. *Carbohydr. Res.* **1986**, *149*, C9-C12.
- (127) Andersson, F.; Fügedi, P.; Garegg, P. J.; Nashed, M. *Tetrahedron Lett.* **1986**, *27*, 3919-3922.
- (128) Veeneman, G. H.; van Leeuwen, S. H.; van Boom, J. H. *Tetrahedron Lett.* **1990**, *31*, 1331-1334.
- (129) Koenigs, W.; Knorr, E. *Ber. Deutsch. Chem. Ges.* **1901**, *34*, 957-981.
- (130) Helferich, B.; Zirner, J. *Chem. Ber.* **1962**, *95*, 2616-2622.
- (131) Reynolds, D. D.; Evans, W. L. *J. Am. Chem. Soc.* **1938**, *60*, 2559-2561.
- (132) Zemplén, G.; Gerecs, A. *Chem. Ber.* **1930**, *63*, 2720-2729.
- (133) Helferich, B.; Weis, K. *Chem. Ber.* **1956**, *89*, 314-321.
- (134) Kronzer, F. J.; Schuerch, C. *Carbohydr. Res.* **1973**, *27*, 379-390.
- (135) Lemieux, R. U.; Hendriks, K. B.; Stick, R. V.; James, K. *J. Am. Chem. Soc.* **1975**, *97*, 4056-4062.
- (136) Paulsen, H.; Richter, A.; Sinnwell, V.; Stenzel, P. *Carbohydr. Res.* **1978**, *64*, 339-364.
- (137) Rexford, L. T.; Rashmi, D.; Saeed, A. A.; Khushi, L. M. *Carbohydr. Res.* **1987**, *169*, 201-212.
- (138) Boutet, J.; Kim, T. H.; Guerreiro, C.; Mulard, L. *Tetrahedron Lett.* **2008**, *49*, 5339-5342.
- (139) Myszka, H.; Bednarczyk, D.; Najder, M.; Kaca, W. *Carbohydr. Res.* **2003**, *338*, 133-141.

- (140) Wrodnigg, T. M.; Stütz, A. E. *Angew. Chem. Int. Ed.* **1999**, *38*, 827-828.
- (141) Nishida, Y.; Thiem, J. *Carbohydr. Res.* **1994**, *263*, 295-301.
- (142) Cheshev, P. E.; Tsvetkov, Y. E.; Nifantiev, N. E. *Russian Chem. Bull.* **2006**, *55*, 152-158.
- (143) Motawia, M. S.; Marcussen, J.; Møller, B. L. *J. Carbohydr. Chem.* **1995**, *14*, 1279-1294.
- (144) Yeung, B. K. S.; Chong, P. Y. C.; Petillo, P. A. *J. Carbohydr. Chem.* **2002**, *21*, 799-865.
- (145) Poletti, L.; Lay, L. *Eur. J. Org. Chem.* **2003**, 2999-3024.
- (146) Sinay, P.; Jacquinet, J.-C.; Petitou, M.; Duchaussoy, P.; Lederman, I.; Choay, J. *Carbohydr. Res.* **1984**, *132*, C5-C9.
- (147) Ichikawa, Y.; Monden, R.; Kuzuhara, H. *Tetrahedron Lett.* **1986**, *27*, 611-614.
- (148) Haller, M. F.; Boons, G.-J. *Eur. J. Org. Chem.* **2002**, 2033-2038.
- (149) Petitou, M.; Duchaussoy, P.; Lederman, I.; Choay, J.; Sinay, P.; Jacquinet, J.-C.; Torri, G. *Carbohydr. Res.* **1986**, *147*, 221-236.
- (150) Petitou, M.; Duchaussoy, P.; Lederman, I.; Choay, J.; Jacquinet, J.-C.; Sinay, P.; Torri, G. *Carbohydr. Res.* **1987**, *167*, 67-75.
- (151) Tatai, J.; Fügedi, P. *Tetrahedron* **2008**, *64*, 9865-9873.
- (152) Du, Y.; Vlahov, I. R.; Linhardt, R. J. *Carbohydr. Lett.* **1998**, *3*, 53-58.
- (153) Bergmann, M.; Wolff, W. W. *Ber. Deutsch. Chem. Ges.* **1923**, *56B*, 1060-1065.
- (154) Daragics, K.; Fügedi, P. *Tetrahedron* **2010**, *66*, 8036-8046.
- (155) Wang, C.-C.; Lee, J.-C.; Luo, S.-Y.; Kulkarni, S. S.; Huang, Y.-W.; Lee, C.-C.; Chang, K.-L.; Hung, S.-C. *Nature* **2007**, *446*, 896-869.
- (156) Français, A.; Urban, D.; Beau, J.-M. *Angew. Chem. Int. Ed.* **2007**, *46*, 8662-8665.
- (157) Corey, E. J.; Samuelsson, B. *J. Org. Chem.* **1984**, *49*, 4735-4735.
- (158) Varki, A.; Cummings, R.; Esko, J.; Freeze, H.; Hart, G.; Marth, J. *Essential of Glycobiology*; Cold Springs Harbor Laboratory Press, 1999.

- (159) Mathews, C.; van Holde, K.; Ahern, K. *Biochemistry*; 3rd ed. Addison Wesley Longman, 2000.
- (160) Varki, A. *Glycobiology* **1993**, *3*, 97-130.
- (161) Arsequell, G.; Valencia, G. *Tetrahedron: Asymmetry* **1999**, *10*, 3045-3094.
- (162) Bill, R. M.; Flitsch, S. L. *Chem. Biol.* **1996**, *3*, 145-149.
- (163) Feizi, T.; Bundle, D. *Curr. Opin. Struct. Biol.* **1994**, *4*, 673-676.
- (164) Varki, A. *Glycobiology* **1993**, *3*, 97-130.
- (165) Hanessian, S.; Lou, B. *Chem. Rev.* **2000**, *100*, 4443-4464.
- (166) Tsuda, Y.; Haque, M. E.; Yoshimoto, K. *Chem. Pharm. Bull.* **1983**, *31*, 1612-1624.
- (167) Garegg, P. J.; Maloisel, J.-L.; Oscarson, S. *Synthesis* **1995**, 409-414.
- (168) Kaji, E.; Harita, N. *Tetrahedron Lett.* **2000**, *41*, 53-56.
- (169) Kaji, E. Shibayama, K.; In, K. *Tetrahedron Lett.* **2003**, *44*, 4881-4885.
- (170) Greene, T. W.; Wuts, P. G. M. *Protective Groups in Organic Synthesis*; 3rd ed. Wiley, 1999.
- (171) Kaji, E.; Nishino, T.; Ishige, K.; Ohya, Y.; Shirai, Y. *Tetrahedron Lett.* **2010**, *51*, 1570-1573.
- (172) Gouliaras, C.; Lee, D.; Chan, L.; Taylor, M. S. *J. Am. Chem. Soc.* **2011**, *133*, 13926-13929.
- (173) Lee, D.; Taylor, M. S. *J. Am. Chem. Soc.* **2011**, *133*, 3724-3727.
- (174) Chan, L.; Taylor, M. S. *Org. Lett.* **2011**, *13*, 3090-3093.
- (175) Matwiejuk, M.; Thiem, J. *Eur. J. Org. Chem.* **2011**, 5860-5878.
- (176) Ferrier, R. J. *J. Chem. Soc.* **1961**, 2325-2330.
- (177) Lindhorst, T. K. *Essentials of Carbohydrate Chemistry and Biochemistry*; 3rd ed. Wiley-VCH, 2007.
- (178) Makarov, I.; Fristrup, P.; Madsen, R. Manuscript in preparation.
- (179) Maggi, A.; Madsen, R. *Organometallics* submitted.

- (180) Sølvehøj, A.; Madsen, R. *Organometallics* **2011**, *30*, 6044-6048.
- (181) Gottlieb, H. E.; Kotlyar, V.; Nudelman, A. *J. Org. Chem.* **1997**, *62*, 7512-7515.
- (182) Ito, S.; Hayashi, A.; Komai, H.; Yamaguchi, H.; Kubota, Y.; Asami, M. *Tetrahedron* **2011**, *67*, 2081-2089.
- (183) Zhang, L.; Zha, Z.; Zhang, Z.; Li, Y.; Wang, Z. *Chem. Commun.* **2010**, *46*, 7196-7198.
- (184) Yasuda, M.; Fujibayashi, T.; Baba, A. *J. Org. Chem.* **1998**, *63*, 6401-6404.
- (185) Ishino, Y.; Mihara, M.; Kageyama, M. *Tetrahedron Lett.* **2002**, *43*, 6601-6604.
- (186) Snowden, R. L.; Linder, S. M.; Muller, B. L.; Schulte-Elte, K. H. *Helv. Chim. Acta* **1987**, *70*, 1879-1885.
- (187) Choi, D.; Stables, J. P.; Kohn, H. *Bioorg. Med. Chem.* **1996**, *4*, 2105-2114.
- (188) Bosch, I.; Gonzalez, A.; Urpi, F.; Vilarrasa, J. *J. Org. Chem.* **1996**, *61*, 5638-5643.
- (189) Kametani, T.; Umezawa, O. *Chem. Pharm. Bull.* **1966**, *14*, 369-375.
- (190) Chan, W.-K.; Ho, C.-M. Wong, M.-K.; Che, C.-M. *J. Am. Chem. Soc.* **2006**, *128*, 14796-14797.
- (191) Maki, T.; Ishihara, K.; Yamamoto, H. *Org. Lett.* **2006**, *8*, 1431-1434.
- (192) Agwada, V. C. *J. Chem. Eng. Data* **1982**, *27*, 481-483.
- (193) Shioiri, T.; Yokoyama, Y.; Kasai, Y.; Yamada, S. *Tetrahedron* **1976**, *24*, 2211-2217.
- (194) Guranda, D. T.; van Langen, L. M.; van Rantwijk, F.; Sheldon, R. A.; Švedas, V. K. *Tetrahedron: Asymmetry* **2001**, *12*, 1645-1650.
- (195) Starkov, P.; Sheppard, T. D. *Org. Biomol. Chem.* **2011**, *9*, 1320-1323.
- (196) Reference compound was prepared by HBTU mediated coupling between *N*-benzyl-L-prolinol and benzylamine as described in Traverse, J. F.; Zhao, Y.; Hoveyda, A. H.; Snapper, M. L. *Org. Lett.* **2005**, *7*, 3151-3154.
- (197) Zhao, S.; Freeman, J. P.; Bacon, C. L.; Fox, G. B.; O'Driscoll, E.; Foley, A. G.; Kelly, J.; Farrell, U.; Regan, C.; Mizsak, S. A.; Szmuszkovicz, J. *Bioorg. Med. Chem.* **1999**, *7*, 1647-1654.
- (198) Drechsel, E. K. *J. Org. Chem.* **1957**, *22*, 849-851.
- (199) Ramalingan, C.; Park, Y. T. *J. Org. Chem.* **2007**, *72*, 4536-4538.

- (200) Underwood, H. W.; Gale, J. C. *J. Am. Chem. Soc.* **1934**, *56*, 2117-2120.
- (201) Metz, P.; Mues, C. *Tetrahedron* **1988**, *44*, 6841-6853.
- (202) Jo, Y.; Ju, J.; Choe, J.; Song, K. H.; Lee, S. *J. Org. Chem.* **2009**, *74*, 6358-6361.
- (203) Katritzky, A. R.; Drewniak, M. *J. Chem. Soc., Perkin Trans. 1* **1988**, 2339-2344.
- (204) Qin, D.; Sullivan, R.; Berkovitz, W. F.; Bittman, R.; Rotenberg, S. A. *J. Med. Chem.* **2000**, *43*, 1413-1417.
- (205) Albores, M.; Bestmann, H. J.; Doehla, B.; Hirsch, H.-L.; Roesel, P.; Vostrowsky, O. *Liebigs Ann. Chem.* **1993**, *3*, 231-236.
- (206) Silva, D. J.; Wang, H.; Allanson, N. M.; Jain, R. K.; Sofia, M. J. *J. Org. Chem.* **1999**, *64*, 5926-5929.
- (207) Dempsey, A. M.; Hough, L. *Carbohydr. Res.* **1975**, *41*, 63-76.
- (208) Blatter, G.; Beau, J. M.; Jacquinet, J. C. *Carbohydr. Res.* **1994**, *260*, 189-202.
- (209) Weng, S.-S. *Tetrahedron Lett.* **2009**, *50*, 6414-6417.
- (210) Lemieux, R. U. *Can. J. Chem.* **1951**, *29*, 1079-1091.
- (211) Vic, G.; Hastings, J. J.; Howarth, O. W.; Crout, D. H. G. *Tetrahedron: Asymmetry* **1996**, *7*, 709-720.
- (212) Gauthier, C.; Legault, J.; Lebrun, M.; Dufour, P.; Ichette, A. *Bioorg. Med. Chem.* **2006**, *14*, 6713-6725.
- (213) Salinas, A. E.; Sproviero, J. F.; Deulofeu, V. *Carbohydr. Res.* **1987**, *170*, 71-99.
- (214) Hodosi, G.; Kovac, P. *Carbohydr. Res.* **1997**, *303*, 239-243.
- (215) Mbadugha, B. N. A.; Menger, F. M. *Org. Lett.* **2003**, *5*, 4041-4044.
- (216) Mitchell, S. A.; Pratt, M. R.; Hruby, V. J.; Polt, R. *J. Org. Chem.* **2001**, *66*, 2327-2342.
- (217) Lundt, I.; Pedersen, C. *Carbohydr. Res.* **1974**, *35*, 187-194.

## Appendix – Publications

- 1) Osztrovsky, G.; Holm, T.; Madsen, R. “Ultrafast Grignard addition reactions in the presence of water” *Org. Biomol. Chem.* **2010**, *8*, 3402-3404
- 2) Dam, J. H., Osztrovsky, G.; Nordstrøm, L. U.; Madsen, R. “Amide synthesis from alcohols and amines catalyzed by ruthenium *N*-heterocyclic carbene complexes” *Chem. Eur. J.*, **2010**, *16*, 6820-6827.

# Ultrafast Grignard addition reactions in the presence of water

Gyorgyi Osztrovszky, Torkil Holm\* and Robert Madsen\*

Received 25th May 2010, Accepted 9th June 2010

First published as an Advance Article on the web 25th June 2010

DOI: 10.1039/c0ob00170h

The addition of allylmagnesium bromide and benzylmagnesium chloride to carbonyl compounds was investigated in the presence of protic reagents such as water and the rate of carbonyl addition was found to be comparable to the rate of protonation by the reagent.

The Grignard addition reaction is one of the most important organometallic transformations for forming a carbon–carbon bond.<sup>1</sup> The reaction between an organomagnesium halide and a carbonyl compound is performed under strictly anhydrous conditions in an ethereal solution (usually diethyl ether or THF). The exclusion of water is crucial since the protonation of the Grignard reagent is believed to be almost instantaneous. Therefore it is surprising that quantum mechanics calculations for the reaction of allylmagnesium bromide with water and acetone have suggested similar activation energies towards protonation and addition.<sup>2</sup> In these calculations, however, the addition is based on a polar mechanism and allyl Grignard is believed to add by a single electron transfer mechanism.<sup>3</sup> One of us have measured the rate for the reaction between allylmagnesium bromide and acetone by competition kinetics and found that allyl Grignard adds  $1.5 \times 10^5$  times faster than the corresponding butyl reagent.<sup>4</sup> In fact, allylmagnesium bromide reacts with acetone at a rate which is near the diffusion controlled maximum. Since the addition reaction is extremely fast it may be able to compete with the protonation by a protic (co)solvent such as water. It should also be noted that the one-pot reaction between allyl bromide, magnesium metal and benzaldehyde in aqueous media gives rise to the addition product in moderate to good yields (Barbier conditions).<sup>5</sup> The mechanism is believed to involve a rate-determining single electron transfer reaction to the aldehyde,<sup>5,6</sup> but it is not known whether an allylmagnesium halide is actually formed under these conditions. Based on these observations we decided to compare the rate of addition to the rate of protonation by several Grignard reagents especially allyl Grignard.

The first experiments were carried out with allylmagnesium bromide in diethyl ether (containing octane as an internal standard) which was mixed with an equimolar mixture of acetone and water in diethyl ether.† Remarkably, the yield of the addition product was found to be around 90% (Table 1, entry 1 and 2) indicating that the addition reaction should be much faster than the protonation of the reagent. Since the result was unexpected the investigation was widened to include a number of Grignard reagents reacting with a number of protic reagents.

When allylmagnesium bromide was reacted with acetone in the presence of alcohols or benzoic acid yields of the addition

products were in the 52–63% range indicating a higher degree of protonation (entries 3–5). Similar results were obtained when benzaldehyde was used as the carbonyl compound. The best result was obtained with water as the proton source giving 75% yield of the addition product (entry 6) while methanol, phenol and benzoic acid gave yields around 42–63% (entries 7–10). Methyl benzoate, acetophenone and *p*-methoxybenzaldehyde furnished moderate yield of the addition product in competition with water, methanol and phenol (entries 11–15). With methyl benzoate only double addition to afford the tertiary alcohol was observed and the intermediate ketone was not detected. Besides allylmagnesium bromide, benzylmagnesium chloride also reacted sufficiently fast with acetone and benzaldehyde to compete to a certain degree with protonation by water and alcohols (entries 16–22). Butylmagnesium bromide, on the other hand, yielded only trace amounts of the addition products in similar reactions (entry 23 and 24).

From these experiments it is clear that for allylmagnesium bromide the addition to acetone is faster than the protonation by water. The addition to other types of carbonyl compounds such as benzaldehyde, methyl benzoate and acetophenone seem to be slower. Surprisingly, a reversal in reactivity is observed with benzylmagnesium chloride which adds effectively to benzaldehyde in competition with protonation by water while the reaction with acetone is slower. Butylmagnesium bromide, as anticipated, undergoes complete protonation in competition with carbonyl addition.

The reactivities in acetone–water mixtures can be rationalized by the different reactivities of the three Grignard reagents. For allylmagnesium bromide the half-time for addition to acetone has been established to be around one  $\mu\text{s}$ .<sup>4</sup> There is no similar value available for benzylmagnesium chloride, but from the known rate constant for benzylmagnesium bromide<sup>7</sup> and an estimated 10 fold increase on going from the bromide to the chloride<sup>8</sup> it must be assumed that the half-time for the addition is about one ms. For butylmagnesium bromide the half-time for addition to acetone is almost one s.<sup>7</sup> Thus for the extremely reactive allyl Grignard reagent addition competes effectively with protonation while with the less reactive reagents protonation becomes the predominant reaction. However, there are still some inconsistencies in Table 1 which needs to be further addressed particularly why alcohols are better proton sources than water and why protonation seems to be more favoured at higher dilution.

In this regard, it has been shown that in the case of Grignard reagents, competition kinetics do not always give the correct ratio between two reacting reagents competing for a single substrate or when two substrates compete for a single reagent.<sup>4</sup> When a highly reactive reagent is tested in competition with a less reactive reagent the ratios found tend to be statistically controlled (by the relative concentrations) rather than kinetically controlled

Department of Chemistry, Building 201, Technical University of Denmark, DK-2800 Kgs. Lyngby, Denmark. E-mail: th@kemi.dtu.dk; rm@kemi.dtu.dk; Fax: (+45) 4593 3968



**Table 1** Yield of addition product in the reaction of Grignard reagents with carbonyl compounds in the competition with protic compounds†

Entry	Grignard Reagent (0.1 M)	Carbonyl Compd (0.6 M)	Protic Compd (0.6 M)	Yield <sup>a</sup> (%)
1	CH <sub>2</sub> =CHCH <sub>2</sub> MgBr	CH <sub>3</sub> COCH <sub>3</sub>	H <sub>2</sub> O	91
2	CH <sub>2</sub> =CHCH <sub>2</sub> MgBr <sup>b</sup>	CH <sub>3</sub> COCH <sub>3</sub>	H <sub>2</sub> O	90
3	CH <sub>2</sub> =CHCH <sub>2</sub> MgBr	CH <sub>3</sub> COCH <sub>3</sub>	CH <sub>3</sub> OH	56
4	CH <sub>2</sub> =CHCH <sub>2</sub> MgBr	CH <sub>3</sub> COCH <sub>3</sub>	C <sub>2</sub> H <sub>5</sub> OH	63
5	CH <sub>2</sub> =CHCH <sub>2</sub> MgBr	CH <sub>3</sub> COCH <sub>3</sub> <sup>c</sup>	C <sub>6</sub> H <sub>5</sub> COOH <sup>f</sup>	52
6	CH <sub>2</sub> =CHCH <sub>2</sub> MgBr	C <sub>6</sub> H <sub>5</sub> CHO	H <sub>2</sub> O	75
7	CH <sub>2</sub> =CHCH <sub>2</sub> MgBr <sup>d</sup>	C <sub>6</sub> H <sub>5</sub> CHO	CH <sub>3</sub> OH	53
8	CH <sub>2</sub> =CHCH <sub>2</sub> MgBr	C <sub>6</sub> H <sub>5</sub> CHO <sup>e</sup>	CH <sub>3</sub> OH <sup>e</sup>	42
9	CH <sub>2</sub> =CHCH <sub>2</sub> MgBr <sup>f</sup>	C <sub>6</sub> H <sub>5</sub> CHO <sup>g</sup>	C <sub>6</sub> H <sub>5</sub> OH <sup>g</sup>	43
10	CH <sub>2</sub> =CHCH <sub>2</sub> MgBr	C <sub>6</sub> H <sub>5</sub> CHO	C <sub>6</sub> H <sub>5</sub> COOH	63
11	CH <sub>2</sub> =CHCH <sub>2</sub> MgBr <sup>f</sup>	C <sub>6</sub> H <sub>5</sub> COOCH <sub>3</sub>	H <sub>2</sub> O	56
12	CH <sub>2</sub> =CHCH <sub>2</sub> MgBr <sup>f</sup>	C <sub>6</sub> H <sub>5</sub> COOCH <sub>3</sub>	CH <sub>3</sub> OH <sup>h</sup>	40
13	CH <sub>2</sub> =CHCH <sub>2</sub> MgBr <sup>f</sup>	C <sub>6</sub> H <sub>5</sub> COOCH <sub>3</sub>	C <sub>6</sub> H <sub>5</sub> OH	47
14	CH <sub>2</sub> =CHCH <sub>2</sub> MgBr <sup>f</sup>	C <sub>6</sub> H <sub>5</sub> COCH <sub>3</sub>	C <sub>6</sub> H <sub>5</sub> OH	31
15	CH <sub>2</sub> =CHCH <sub>2</sub> MgBr	<i>p</i> -CH <sub>3</sub> OC <sub>6</sub> H <sub>4</sub> CHO	C <sub>6</sub> H <sub>5</sub> OH	35
16	C <sub>6</sub> H <sub>5</sub> CH <sub>2</sub> MgCl	CH <sub>3</sub> COCH <sub>3</sub>	H <sub>2</sub> O	30
17	C <sub>6</sub> H <sub>5</sub> CH <sub>2</sub> MgCl <sup>b</sup>	CH <sub>3</sub> COCH <sub>3</sub>	H <sub>2</sub> O	14
18	C <sub>6</sub> H <sub>5</sub> CH <sub>2</sub> MgCl	C <sub>6</sub> H <sub>5</sub> CHO	H <sub>2</sub> O	89
19	C <sub>6</sub> H <sub>5</sub> CH <sub>2</sub> MgCl	C <sub>6</sub> H <sub>5</sub> CHO	CH <sub>3</sub> OH	63
20	C <sub>6</sub> H <sub>5</sub> CH <sub>2</sub> MgCl	C <sub>6</sub> H <sub>5</sub> CHO	C <sub>2</sub> H <sub>5</sub> OH	46
21	C <sub>6</sub> H <sub>5</sub> CH <sub>2</sub> MgCl	C <sub>6</sub> H <sub>5</sub> CHO	C <sub>6</sub> H <sub>5</sub> OH	29
22	C <sub>6</sub> H <sub>5</sub> CH <sub>2</sub> MgCl	<i>p</i> -CH <sub>3</sub> OC <sub>6</sub> H <sub>4</sub> CHO <sup>i</sup>	C <sub>6</sub> H <sub>5</sub> OH <sup>i</sup>	18
23	CH <sub>3</sub> (CH <sub>2</sub> ) <sub>3</sub> MgBr	CH <sub>3</sub> COCH <sub>3</sub>	H <sub>2</sub> O	2
24	CH <sub>3</sub> (CH <sub>2</sub> ) <sub>3</sub> MgBr	C <sub>6</sub> H <sub>5</sub> CHO	CH <sub>3</sub> OH	0

<sup>a</sup> GC yield. <sup>b</sup> 0.01 M. <sup>c</sup> 0.34 M. <sup>d</sup> 0.25 M. <sup>e</sup> 0.5 M. <sup>f</sup> 0.16 M. <sup>g</sup> 0.3 M. <sup>h</sup> 1.2 M. <sup>i</sup> 0.2 M.

(by the reactivities). As originally explained by Francis<sup>9</sup> the cause is that in “the meeting zone” when the solutions get in contact, the highly reactive reagent gets depleted locally. This gives the less reactive reagent a chance to get more than its fair share of the substrate. In the case of a water–acetone mixture meeting a Grignard reagent the possibility exists of water being removed by the Grignard reagent leaving acetone in dry diethyl ether ready to be attacked by unreacted Grignard reagent. It is impossible to predict the importance of this “depletion” or “scavenging” effect since it depends both on the concentrations used, on the method of mixing, and on the nature of reaction products. The effect tends to be smaller with higher dilution and could explain the higher degree of protonation in more dilute mixtures.

It should also be noted that a Grignard reagent is a combination of alkylmagnesium halide and dialkylmagnesium (and more complex oligomeric species) in a Lewis donor solvent. The ligands around magnesium exchange rapidly and the Schlenk equilibrium (Scheme 1) is positioned differently in weakly or strongly donating solvents, *e.g.* it is shifted from left to right by adding THF to an ethereal solution of an alkylmagnesium halide.<sup>1a</sup> The shift in the position of the Schlenk equilibrium is a result of small differences in the Lewis acidity of the various components which decrease in the order: MgBr<sub>2</sub> > RMgBr ≫ R<sub>2</sub>Mg. The complexation energy of one water molecule to allylmagnesium bromide has been calculated to −23.1 kcal mol<sup>−1</sup> which reflects the strong Lewis acidity of the metal in the Grignard reagent.<sup>2</sup> While the overall Schlenk equilibrium is fast but measurable, the rate of

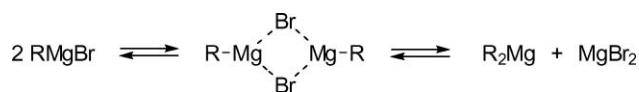
**Scheme 1** The Schlenk equilibrium.

ligand exchange around the individual magnesium atoms must be assumed to be diffusion controlled.

In all the experiments reported in this work the Grignard reagents are added to an excess of the two competing substrates (inverse addition). When the competition is between a carbonyl compound and water, it seems indicated that water will coordinate to magnesium. If coordinated water is less reactive in the protonation reaction, addition to the carbonyl group will be more favoured. Since alcohols coordinate less effectively to magnesium it will also explain the higher degree of protonation when Grignard reagents are competing with alcohols than with water.

The deactivation should be caused by coordination of water to any electrophilic magnesium compound, magnesium bromide inclusive. It was therefore decided to repeat the addition to acetone with extra magnesium bromide added. In fact, when allylmagnesium bromide was mixed with one equivalent of magnesium bromide and then added to an equimolar mixture of acetone and water, the yield of the addition product was quantitative. This is a pronounced increase compared to the 91% yield in Table 1, entry 1 and confirms that magnesium compounds may serve as water scavengers to some extent in fast Grignard addition reactions. The same was observed when allylmagnesium bromide with one equivalent of magnesium bromide was added to an equimolar mixture of benzaldehyde and water. In this case, 85% yield of the addition product was obtained which should be compared to 75% in the absence of added magnesium bromide (Table 1, entry 6)

A method to avoid the scavenging effect is to include the two competing groups in the same molecule giving them identical chances for meeting a reactive R–Mg entity in an intramolecular competition. We therefore made a series of experiments in which we reacted a Grignard reagent with bifunctional substrates containing both a hydroxy group and a carbonyl group. The results are shown in Table 2.

**Table 2** Yield of addition product in the reaction of Grignard reagents with carbonyl compounds containing a hydroxyl group<sup>†</sup>

Entry	Grignard Reagent	Bifunctional Compd	Yield <sup>a</sup> (%)
1	0.16 M CH <sub>2</sub> =CHCH <sub>2</sub> MgBr	0.3 M <i>p</i> -HOC <sub>6</sub> H <sub>4</sub> CHO	5
2	0.16 M CH <sub>2</sub> =CHCH <sub>2</sub> MgBr	0.3 M <i>m</i> -HOC <sub>6</sub> H <sub>4</sub> CHO	30
3	0.16 M CH <sub>2</sub> =CHCH <sub>2</sub> MgBr	0.3 M <i>o</i> -HOC <sub>6</sub> H <sub>4</sub> CHO	0
4	0.16 M CH <sub>2</sub> =CHCH <sub>2</sub> MgBr	0.3 M <i>p</i> -HOC <sub>6</sub> H <sub>4</sub> COCH <sub>3</sub>	13
5	0.16 M CH <sub>2</sub> =CHCH <sub>2</sub> MgBr	0.3 M <i>p</i> -HOC <sub>6</sub> H <sub>4</sub> COOCH <sub>3</sub>	2
6	0.1 M C <sub>6</sub> H <sub>5</sub> CH <sub>2</sub> MgCl	0.4 M <i>p</i> -HOC <sub>6</sub> H <sub>4</sub> CHO	0
7	0.1 M C <sub>6</sub> H <sub>5</sub> CH <sub>2</sub> MgCl	0.4 M <i>m</i> -HOC <sub>6</sub> H <sub>4</sub> CHO	0
8	0.1 M C <sub>6</sub> H <sub>5</sub> CH <sub>2</sub> MgCl	0.4 M <i>p</i> -HOC <sub>6</sub> H <sub>4</sub> COCH <sub>3</sub>	0
9	0.2 M CH <sub>2</sub> =CHCH <sub>2</sub> MgBr	0.4 M C <sub>6</sub> H <sub>5</sub> COOH	18
10	0.1 M CH <sub>2</sub> =CHCH <sub>2</sub> MgBr	0.25 M CH <sub>3</sub> (CH <sub>2</sub> ) <sub>6</sub> COOH	9
11	0.1 M C <sub>6</sub> H <sub>5</sub> CH <sub>2</sub> MgCl	0.2 M C <sub>6</sub> H <sub>5</sub> COOH	0

<sup>a</sup> GC yield.

From the table it is clear that the intramolecular competition gives results that are different from the results in the intermolecular competition. With both allylmagnesium bromide and benzylmagnesium chloride a higher degree of protonation is observed in the intramolecular competition. When allylmagnesium bromide was reacted with a mixture of *p*-methoxybenzaldehyde and phenol, the addition/protonation ratio was 35:65 (Table 1, entry 15). However, when the same reagent was added to *p*-hydroxybenzaldehyde the ratio was 5:95 (Table 2, entry 1). Similar allyl Grignard reactions with other hydroxy carbonyl compounds (entries 2–5) also gave lower yields of the addition product than in Table 1. When benzylmagnesium chloride was reacted with a mixture of *p*-methoxybenzaldehyde and phenol, the addition/protonation ratio was 18:82 (Table 1, entry 22). With *p*-hydroxybenzaldehyde as the substrate the ratio was zero (Table 2, entry 6) indicating that the rate of protonation of benzylmagnesium chloride by the hydroxy group is more than hundred times faster than the addition to the aldehyde. The higher degree of protonation in these intramolecular competition experiments confirm that the protic reagent in the intermolecular competition experiments is scavenged to some degree by the magnesium salts.

Similar results are obtained with benzoic acid and octanoic acid, which can also be considered as bifunctional substrates with both a hydroxy group and a carbonyl group (entries 9–11). With allylmagnesium bromide only double addition was observed to afford the tertiary alcohol and the intermediate ketone was not detected. Since the oxygen–hydrogen bond is broken in the protonation reaction a primary deuterium isotope effect might be expected. Experiments with the reaction between allylmagnesium bromide and deuterated benzoic and octanoic acid, however, showed no significant changes in the product distributions from

those obtained with the non-deuterated acids. The ultrafast reactions most likely have early transition states in which case the  $k_H/k_D$  will be close to 1.0.

In conclusion, we have shown that the rate of carbonyl addition may compare with the rate of protonation for two highly reactive Grignard reagents. When the Grignard reagents are added to an excess of two competing substrates of which one has a carbonyl group and the other a hydroxy group rather high yields of the addition products may be obtained (intermolecular competition). This is seen especially with allylmagnesium bromide, but also to some extent with benzylmagnesium chloride while butylmagnesium bromide does not undergo carbonyl addition in the presence of protic reagents. The phenomenon is caused to some degree by a scavenging effect from electrophilic magnesium compounds which remove water or other hydroxy compounds by complexation and leave the carbonyl compound free to react with the alkylmagnesium reagent. When the competition is carried out in an intramolecular fashion with substrates containing both a carbonyl group and a hydroxy group the scavenging effect is absent and only allylmagnesium bromide is able to form the addition product in low to moderate yield.

## Notes and references

<sup>†</sup> **General procedure for competition experiments:** Allylmagnesium bromide and benzylmagnesium chloride were prepared under argon in diethyl ether (distilled from benzophenone ketyl) from reagent grade magnesium by slow addition (6 h) of distilled allyl bromide and benzyl chloride. Solutions of the Grignard reagent (10 mL) and the substrates (10 mL) were prepared separately in 20 mL syringes which were connected with a polyethylene capillary tube. The Grignard solution contained 1 mol of octane per mol of Grignard reagent as an internal standard. The Grignard reagent was pressed into the syringe with the substrate solution within 2–3 s. The heterogeneous reaction mixture was shaken with saturated ammonium chloride solution and the organic layer isolated. The solution was analysed by quantitative GC and the peaks for the products were measured relative to the peak for octane. To obtain complete conversion the Grignard solution was reacted with an excess of the substrate mixture. Each experiment was repeated twice and the average yield reported in Tables 1 and 2.

- (a) *Handbook of Grignard Reagents*, ed. G. S. Silverman and P. E. Rakita, Marcel Dekker, New York, 1996; (b) *Grignard Reagents – New Developments*, ed. H. G. Richey, Jr., John Wiley & Sons, Chichester, 2000.
- L. W. Chung, T. H. Chan and Y.-D. Wu, *Organometallics*, 2005, **24**, 1598–1607.
- J. J. Gajewski, W. Bocian, N. J. Harris, L. P. Olson and J. P. Gajewski, *J. Am. Chem. Soc.*, 1999, **121**, 326–334.
- T. Holm, *J. Org. Chem.*, 2000, **65**, 1188–1192.
- W.-C. Zhang and C.-J. Li, *J. Org. Chem.*, 1999, **64**, 3230–3236.
- J. H. Dam, P. Fristrup and R. Madsen, *J. Org. Chem.*, 2008, **73**, 3228–3235.
- T. Holm, *Acta Chem. Scand., Ser. B*, 1983, **37b**, 567–584.
- T. Holm, *Tetrahedron Lett.*, 1966, **7**, 3329–3336.
- A. W. Francis, *J. Am. Chem. Soc.*, 1926, **48**, 655–672.

## Amide Synthesis from Alcohols and Amines Catalyzed by Ruthenium N-Heterocyclic Carbene Complexes

Johan Hygum Dam, Gyorgyi Osztrovszky, Lars Ulrik Nordstrøm, and Robert Madsen\*<sup>[a]</sup>

**Abstract:** The direct synthesis of amides from alcohols and amines is described with the simultaneous liberation of dihydrogen. The reaction does not require any stoichiometric additives or hydrogen acceptors and is catalyzed by ruthenium N-heterocyclic carbene complexes. Three different catalyst systems are presented that all employ 1,3-diisopropylimidazol-2-ylidene (IiPr) as the carbene ligand. In addition, potassium *tert*-butoxide and a tricycloalkylphosphine are required for the amidation to proceed. In the first system, the active catalyst is generated in situ from [RuCl<sub>2</sub>(cod)] (cod = 1,5-cyclooctadiene), 1,3-diisopropylimidazolium chloride, tricyclopentylphosphoni-

um tetrafluoroborate, and base. The second system uses the complex [RuCl<sub>2</sub>(IiPr)(*p*-cymene)] together with tricyclohexylphosphine and base, whereas the third system employs the Hoveyda–Grubbs 1st-generation metathesis catalyst together with 1,3-diisopropylimidazolium chloride and base. A range of different primary alcohols and amines have been coupled in the presence of the three catalyst systems to afford the corresponding amides in moderate to excellent yields. The best

results are obtained with sterically unhindered alcohols and amines. The three catalyst systems do not show any significant differences in reactivity, which indicates that the same catalytically active species is operating. The reaction is believed to proceed by initial dehydrogenation of the primary alcohol to the aldehyde that stays coordinated to ruthenium and is not released into the reaction mixture. Addition of the amine forms the hemiaminal that undergoes dehydrogenation to the amide. A catalytic cycle is proposed with the {(IiPr)Ru<sup>II</sup>} species as the catalytically active components.

**Keywords:** alcohols • amides • carbene ligands • dehydrogenation • ruthenium

### Introduction

The amide is one of the most prevalent linkages in organic chemistry. It is the key functional group in peptides and a number of polymers and is also found in many pharmaceuticals and natural products.<sup>[1]</sup> The synthesis of amides has been the subject of intense studies and numerous methods have been developed.<sup>[2]</sup> However, cost effective, high-yielding and waste-free procedures with a broad substrate scope are still in high demand. The direct synthesis of amides by thermal dehydration of carboxylic acids and amines has a

large activation energy due to the formation of the corresponding ammonium salt and this method generally requires a temperature above 160 °C.<sup>[2]</sup> The temperature can be significantly lowered by catalyzing the dehydration with specially designed areneboronic acids<sup>[3]</sup> or heterogeneous silica catalysts<sup>[4]</sup> if water at the same time is removed irreversibly. The most common methods for amide synthesis employ activated derivatives of the carboxylic acid, such as the chloride and the anhydride.<sup>[2]</sup> The activated derivatives may also be generated in situ by employing stoichiometric coupling reagents, such as carbodiimides, uronium, and phosphonium salts,<sup>[5]</sup> for which the latter two are the methods of choice in peptide synthesis. Other general procedures for amide synthesis include the Beckman rearrangement,<sup>[6]</sup> Staudinger ligations,<sup>[7]</sup> oxidative amidation of aldehydes,<sup>[8]</sup> coupling of  $\alpha$ -ketoacids and hydroxylamines,<sup>[9]</sup> and amidation of ketones and thioacids with azides.<sup>[10]</sup> More recently, a number catalytic procedures have been developed including amidation—hydrolysis of *gem*-dihaloolefins,<sup>[11]</sup> redox rearrangement of  $\alpha$ -functionalized aldehydes,<sup>[12]</sup> and aminocarbonylation of aryl halides and terminal alkynes.<sup>[13]</sup>

[a] Dr. J. H. Dam, G. Osztrovszky, Dr. L. U. Nordstrøm, Prof. Dr. R. Madsen  
Department of Chemistry, Building 201  
Technical University of Denmark  
2800 Kgs. Lyngby (Denmark)  
Fax: (+45) 4593-3968  
E-mail: rm@kemi.dtu.dk

Supporting information for this article is available on the WWW under <http://dx.doi.org/10.1002/chem.201000569>.

Very recently, amide synthesis has become possible by the direct metal-catalyzed coupling of primary alcohols and amines with the concomitant extrusion of dihydrogen (Scheme 1). The reaction presumably occurs by initial dehydrogenation of the alcohol to the aldehyde followed by hemiaminal formation with the amine and subsequent dehydrogenation to the amide.

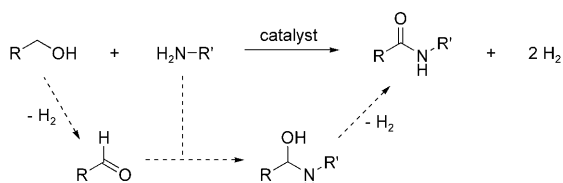

Scheme 1. Dehydrogenative amide formation from primary alcohols and amines.

drogenation of the alcohol to the aldehyde followed by hemiaminal formation with the amine and subsequent dehydrogenation to the amide. The amidation has been achieved both in the presence<sup>[14,15]</sup> and absence<sup>[16–18]</sup> of hydrogen scavengers. The latter protocol is the most attractive in which no stoichiometric additives are necessary and dihydrogen is produced as the only byproduct. To date, three different catalyst systems have been reported for this atom-economical amidation procedure for which two are homogeneous protocols and the latter a heterogeneous method. The first system was presented by Milstein et al. in 2007 for which a ruthenium complex with a PNN-type pincer ligand was shown to be an effective catalyst for the coupling of primary alcohols and amines with the liberation of dihydrogen.<sup>[16]</sup> The following year our laboratory showed that the same transformation could be performed with an in situ generated ruthenium N-heterocyclic carbene (NHC) catalyst.<sup>[17,19]</sup> In 2009, Shimizu et al. achieved the dehydrogenative amide synthesis with a silver cluster supported on  $\gamma$ -alumina as the catalyst.<sup>[18]</sup> Of these three systems the in situ generated ruthenium carbene catalyst is easily modified and can be carried out with commercially available reagents.

Herein, we report a full account on our studies of ruthenium N-heterocyclic carbene catalysts in the dehydrogenative amidation from primary alcohols and amines. We demonstrate that the reaction can be achieved with three different (pre)catalysts and provide further support for the catalytically active species.

## Results and Discussion

**Catalyst development:** 2-Phenylethanol and benzylamine were selected as test substrates for optimizing the amidation procedure. Initial experiments revealed that the reaction could be achieved with a ruthenium(II) precursor in the presence of an in situ generated N-heterocyclic carbene (Table 1). To prevent rapid deactivation of the catalyst, it was also necessary to add an additional ligand. A range of phosphine ligands and other ligands could be used for this purpose for which PCy<sub>3</sub> gave the best result and was select-

Table 1. Amidation with catalysts generated in situ.

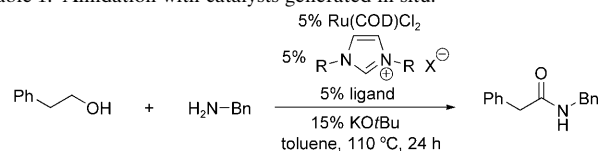

Entry	R	X	Ligand	Yield [%] <sup>[a]</sup>
1	Mes	Cl	PPh <sub>3</sub>	21
2	Mes	Cl	P( <i>o</i> -tol) <sub>3</sub>	26
3	Mes	Cl	P(2-furyl) <sub>3</sub>	26
4	Mes	Cl	PrBu <sub>3</sub>	22
5	Mes	Cl	PCy <sub>3</sub>	27
6	Mes	Cl	O=PPh <sub>3</sub>	24
7	Mes	Cl	AsPh <sub>3</sub>	24
8	Mes	Cl	pyridine	12
9	Me	(MeO) <sub>2</sub> PO <sub>2</sub>	PCy <sub>3</sub>	53
10	<i>i</i> Pr	Cl	PCy <sub>3</sub>	92
11	Cy	BF <sub>4</sub>	PCy <sub>3</sub>	84
12	<i>t</i> Bu	BF <sub>4</sub>	PCy <sub>3</sub>	68
13	<i>i</i> Pr	Cl	PCyp <sub>3</sub>	98
14	<i>i</i> Pr	Cl	PCyp <sub>3</sub> ·HBF <sub>4</sub>	92 <sup>[b]</sup>

[a] GC yield. [b] With 20% of KOtBu.

ed for further studies (Table 1, entries 1–8). The influence of the substituents on the N-heterocyclic carbene was then investigated in detail. These substituents had a pronounced impact on the amidation and the isopropyl group was found to give the highest yield (entries 9–12). A number of more substituted imidazolium salts gave less than 25% yield under the same conditions.<sup>[20]</sup> Carbenes with a saturated backbone, that is, imidazolin-2-ylidenes, gave significantly lower yields than carbenes with an unsaturated backbone.<sup>[17]</sup> Potassium *tert*-butoxide was selected as the base for generating the carbene since it is easy to handle. Similar yields were obtained with potassium hexamethyldisilazide, whereas the use of cesium carbonate resulted in lower yields. The purpose of the base is not only to deprotonate the imidazolium salt, but also to promote the amide formation. Various amounts of base were investigated and the optimum amount was found to be three times the amount of the imidazolium salt. With 1,3-diisopropylimidazol-2-ylidene as the carbene of choice, the phosphine ligand was investigated again. In this case, tricyclopentylphosphine (PCyp<sub>3</sub>) gave a slight improvement over PCy<sub>3</sub>. The improvement was not only measured in the yield at the end of the reaction, but also after 3 h when PCyp<sub>3</sub> showed 67% conversion and PCy<sub>3</sub> only 56% (entries 10 and 13). However, PCyp<sub>3</sub> is a liquid and significantly less stable than the tricyclohexyl congener. Therefore, the corresponding crystalline HBF<sub>4</sub> salt<sup>[21]</sup> was employed at the expense of additional base (entry 14). The isolated yields from the experiments in entries 13 and 14 were the same and the catalyst system in entry 14 was selected for general use and denoted catalyst A.

Since the catalytically active species in this reaction may be a ruthenium(II)chloride N-heterocyclic carbene complex it would be of interest to study the reaction with a more well-defined complex. This may lead to a new catalyst system and a better understanding of the mechanism. At-

tempts to isolate a carbene complex from the reaction between 1,3-diisopropylimidazolium chloride,  $[\text{RuCl}_2(\text{cod})]$ , phosphine, and base were not successful and the in situ generated carbene complex appears to be very sensitive. Instead, we turned our attention to the known *p*-cymene complexes of ruthenium(II)chloride and N-heterocyclic carbenes.<sup>[22]</sup> These are stable and coordinatively saturated complexes that have been used for hydrogenation and cyclopropanation of olefins.<sup>[22]</sup> It is known that the *p*-cymene ligand is released at about 85 °C<sup>[23]</sup> and with the amidation being performed in refluxing toluene these complexes appear well suited as catalyst precursors. Traditionally, the *p*-cymene complexes have been prepared by transfer of the free N-heterocyclic carbene to  $[\text{RuCl}_2(\text{p-cymene})]_2$ .<sup>[24]</sup> More recently, the carbene transfer has become possible by reaction of 1,3-dialkylimidazolium chlorides with silver oxide in dichloromethane.<sup>[25]</sup> By this method the corresponding silver carbene is generated and transmetallated in situ with  $[\text{RuCl}_2(\text{p-cymene})]_2$ , which makes it unnecessary to isolate the free carbene. In this way, complexes **1** and **2** were generated in excellent yield and isolated by flash chromatography (Scheme 2). The structure of **2** has previously been confirmed by X-ray crystallography.<sup>[24c]</sup> Except for the two different alkyl groups, the <sup>1</sup>H and <sup>13</sup>C NMR spectroscopic data for **1** and **2** are very similar with the carbene carbon atom in both cases located at  $\delta = 171$  ppm in the <sup>13</sup>C NMR spectrum. To probe the influence of the halide on ruthenium, the corresponding diiodide complex **3** was also prepared. In this case, only a 56% yield of **3** was obtained since the carbene transfer between 1,3-dicyclohexylimidazolium chloride and  $[\text{RuI}_2(\text{p-cymene})]_2$  gave a mixture of dichloride **2** and diiodide **3** that were separated by preparative TLC.

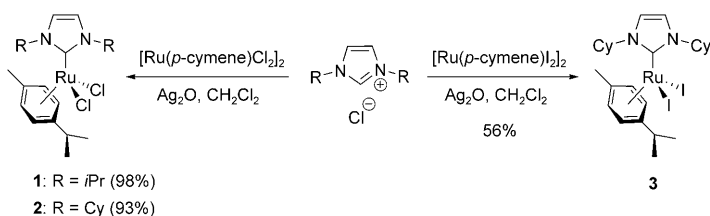

Scheme 2. Synthesis of NHC ruthenium *p*-cymene complexes.

Complexes **1–3** were tested in the amidation with 2-phenylethanol and benzylamine, and the yield was measured after both 3 and 24 h (Table 2). Again, the reaction required a base for the amidation to proceed. A phosphine was also required to obtain a high yield of the amide. Without phosphine, less than 70% of the amide was observed after 24 h. The phosphine salt  $\text{PCy}_3 \cdot \text{HBF}_4$ <sup>[21]</sup> was less effective with complexes **1** and **2** and afforded below 70% yield of the amide after 24 h. However, with added  $\text{PCy}_3$  and  $\text{PCyp}_3$  complexes **1** and **2** performed very well in the amidation (Table 2, entries 3–6) and gave results after 3 and 24 h which were very similar to the yields from the in situ generated catalyst (entries 1 and 2). This confirms that an N-heterocyclic

Table 2. Amidation with  $[\text{Ru}(\text{NHC})(\text{p-cymene})]$  complexes.

Entry	Complex	Phosphine	Yield [%] (3 h) <sup>[a]</sup>	Yield [%] (24 h) <sup>[a]</sup>
1	– <sup>[b]</sup>	$\text{PCy}_3$	56	92
2	– <sup>[b]</sup>	$\text{PCyp}_3$	67	98
3	<b>1</b>	$\text{PCy}_3$	65	95
4	<b>1</b>	$\text{PCyp}_3$	53	100
5	<b>2</b>	$\text{PCy}_3$	61	97
6	<b>2</b>	$\text{PCyp}_3$	56	91
7	<b>3</b>	$\text{PCy}_3$	22	50
8	<b>3</b>	$\text{PCyp}_3$	29	44
9	– <sup>[c]</sup>	$\text{PCy}_3$	56	90
10	– <sup>[c]</sup>	$\text{PCyp}_3$	63	87

[a] GC yield. [b] Generated in situ from  $[\text{RuCl}_2(\text{cod})]_2$  and 1,3-diisopropylimidazolium chloride (catalyst A). [c] Generated in situ from  $[\text{RuI}_2(\text{p-cymene})]_2$  and 1,3-dicyclohexylimidazolium chloride.

cyclic carbene ruthenium(II)chloride species is produced under the in situ conditions. Diiodide complex **3**, on the other hand, was less reactive than dichlorides **1** and **2** and more byproducts were formed with this complex (entries 7 and 8). The results with diiodide **3** did not improve by adding 10% of lithium chloride or tetraethylammonium chloride to the reaction. However, when the amidation was performed with an in situ generated catalyst from  $[\text{RuI}_2(\text{p-cymene})]_2$ , 1,3-dicyclohexylimidazolium chloride, phosphine, and base almost the same yields were observed as with  $[\text{RuCl}_2(\text{cod})]$  as the ruthenium precursor (entries 9 and 10). We believe the catalytically active complex in this case is mainly a ruthenium(II)chloride species and not the corresponding iodide complex. No reaction occurred when the amidation was attempted with 5% of **1** and 10% of silver triflate in the presence of phosphine and base. Based on these studies we selected complex **1** together with  $\text{PCy}_3$  for general use and denoted this system catalyst B.

In 2001 Grubbs et al. showed that the Grubbs 2nd-generation metathesis catalyst reacts with dihydrogen to remove the benzylidene ligand, but not the N-heterocyclic carbene ligand.<sup>[26]</sup> This observation prompted us to investigate olefin metathesis catalysts<sup>[27]</sup> since the liberated dihydrogen in the amidation may serve to activate the metathesis catalysts for this transformation. Indeed, reaction of 2-phenylethanol and benzylamine with Grubbs 2nd-generation catalyst and base produced the amide in 49% yield after 24 h (Table 3, entry 1). This is a lower yield than that achieved in Tables 1 and 2, but the saturated N-heterocyclic carbene in Grubbs 2nd-generation catalyst is not the optimum ligand for the amidation. A higher yield was obtained with Hoveyda–Grubbs 2nd-generation catalyst and this did not change by adding  $\text{PCy}_3$  to the reaction (Table 3, entry 2). Interestingly, the Grubbs catalyst with the less sterically demanding *o*-tolyl group<sup>[28]</sup> gave a good yield of the amide (entry 3).

To illustrate the influence of the N-heterocyclic carbene Grubbs 1st-generation and Hoveyda–Grubbs 1st-generation catalysts were also investigated. These two complexes do

Table 3. Amidation with metathesis catalysts.

Entry	Metathesis catalyst	Yield [%] (3 h) <sup>[a]</sup>	Yield [%] (24 h) <sup>[a]</sup>
1		29	49
2		48	65
3		63	92
4		48	71
5		76 <sup>[b]</sup>	100 <sup>[b]</sup>
6		76 <sup>[c]</sup>	96 <sup>[c]</sup>
7		41	60
8		72 <sup>[b]</sup>	97 <sup>[b]</sup>
9		76 <sup>[c]</sup>	100 <sup>[c]</sup>
10		25	42
11		67 <sup>[c]</sup>	100 <sup>[c]</sup>
12		74	97

[a] GC yield. [b] With 5% of 1,3-diisopropylimidazolium chloride and 15% of KOtBu. [c] With 5% of 1,3-dicyclohexylimidazolium chloride and 15% of KOtBu.

not contain an N-heterocyclic carbene and when applied directly in the amidation moderate yields of the product were obtained (Table 3, entries 4 and 7). However, when 1,3-diisopropyl- or 1,3-dicyclohexylimidazol-2-ylidene were generated together with these complexes the yield of the amide increased considerably (entries 5, 6, 8, and 9) and was comparable to the best results in Tables 1 and 2. The modified Grubbs catalyst with the phenyl indenylidene ligand<sup>[29]</sup> showed the same results (entries 10 and 11), which underlines the assumption that the benzylidene group in the metathesis catalyst did not take part in the amidation, but was reduced off by the liberated dihydrogen. A number of other N-heterocyclic carbenes were also generated together with Grubbs 1st-generation catalyst,<sup>[30]</sup> but in all cases lower yields of the amide was obtained. This confirms the results in Table 1 that the imidazol-2-ylidene with 1,3-diisopropyl or 1,3-dicyclohexyl groups are the optimum N-heterocyclic carbenes for the amidation. The in situ formation of the ruthenium N-heterocyclic carbene complex was confirmed by preparing the known cyclohexyl complex in Table 3, entry 12 from Grubbs 1st-generation catalyst.<sup>[31]</sup> When this well-defined complex was applied in the amidation essentially the same yield was obtained as when the complex was generat-

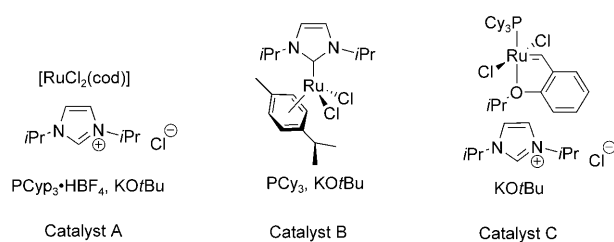

ed in situ (entries 6 and 12). Based on the results in Table 3, Hoveyda–Grubbs 1st-generation catalyst was selected as the metathesis catalyst for the amidation in the presence of 1,3-diisopropylimidazolium chloride and base (catalyst C).

**Substrate scope:** With three optimized catalysts in hand, the substrate scope and limitations could now be more thoroughly explored. Equimolar amounts of various primary alcohols and amines were reacted with catalysts A, B, and C to afford the corresponding amides (Table 4). Sterically unhindered alcohols reacted with primary amines to give the secondary amide in high yields (Table 4, entries 1–3). Benzyl alcohol furnished the corresponding benzamide (entry 4), whereas the aryl chloride in entry 5 afforded the amide without concomitant dechlorination. Hex-5-en-1-ol, on the other hand, gave exclusively the hexanamide with all three catalysts in which the olefin had been reduced with the liberated dihydrogen (entry 6). *N*-benzylethanamine underwent coupling with benzylamine in high yield, which illustrates that the amidation is selective for a primary amine over a secondary amine. Optically pure 1-phenylethylamine participated in the amidation without any sign of epimerization (entry 8). The same was observed with optically pure *N*-benzyl-L-prolinol (entry 9), which is noteworthy since the reaction goes through the corresponding aldehyde. Prolinol gave a lower yield than the other primary alcohols and was not completely consumed in the amidation, which may reflect the slightly higher steric demand around this alcohol. The reaction could also be performed in an intramolecular fashion to afford both five- and seven-membered lactams (entries 10 and 11). On the contrary, aniline and secondary amines did not react with 2-phenylethanol in refluxing toluene. In these cases, the amidation was carried out in refluxing mesitylene, which gave a moderate yield with aniline (entry 12) and a good yield with the secondary amine (entry 13). In the last two cases, self-condensation of the alcohol into the corresponding ester was observed as a by-product, whereas the other examples in Table 4 did not reveal any single compound as a major byproduct. Several other alcohols and amines reacted very poorly or not at all in refluxing mesitylene. *N*-Boc-protected ethanolamine, 1-phenylethane-1,2-diol, 2-pyridineethanol, and 2-(4-bromophenyl)ethanol only gave trace amounts of the amide in the reaction with benzylamine. Several derivatives of glycine<sup>[32]</sup> also failed to give more than trace amounts of the amide in the reaction with 2-phenylethanol. Compared with the results in Table 4, these examples illustrate that the amidation

Table 4. Amidation of amines with primary alcohols.

$$\text{R-OH} + \text{H}_2\text{N-R}' \xrightarrow[\text{toluene, 110 }^\circ\text{C}]{\text{5\% catalyst, KOtBu}} \text{R-C(=O)-NH-R}'$$

Entry	Alcohol	Amine	Amide	Yield [%] <sup>[a]</sup> cat. A	Yield [%] <sup>[a]</sup> cat. B	Yield [%] <sup>[a]</sup> cat. C
1		H <sub>2</sub> N-Bn		93 <sup>[b]</sup>	95	92
2		H <sub>2</sub> N-(CH <sub>2</sub> ) <sub>4</sub>		100 <sup>[b]</sup>	90	95
3		H <sub>2</sub> N-Bn		79	94	86
4		H <sub>2</sub> N-Bn		78	78	80
5		H <sub>2</sub> N-Bn		83 <sup>[b]</sup>	71	73
6		H <sub>2</sub> N-Bn		60	82	78
7		H <sub>2</sub> N-Bn		90	93	87
8				70	85	78
9		H <sub>2</sub> N-Bn		60	53	44
10				65	68	60
11				49	53	48
12		H <sub>2</sub> N-Ph		21 <sup>[c]</sup>	35 <sup>[e]</sup>	33 <sup>[e]</sup>
13				70 <sup>[c]</sup>	65 <sup>[e]</sup>	70 <sup>[e]</sup>

[a] Isolated yield. [b] With 2% of [RuCl<sub>2</sub>(cod)], 2% of ligands and 8% of KOtBu. [c] In mesitylene at 163 °C.

shows some sensitivity towards the steric demand around the alcohol and the amine as well as additional coordinating groups in the substrates. Attempts to use ammonia or ammonia equivalents, such as LiNH<sub>2</sub>, NH<sub>4</sub>HCO<sub>3</sub>, Cu(NH<sub>3</sub>)<sub>4</sub>SO<sub>4</sub>·H<sub>2</sub>O, and Mg(NH<sub>3</sub>)<sub>6</sub>Cl<sub>2</sub>, to afford a primary amide failed completely and only gave the ester in various amounts.

In most cases, the three different catalysts did not show any major differences in yield and reactivity in Table 4. This indicates that the catalytically active species is the same in all three cases. For practical application, however, the most convenient procedure is to generate the active catalyst in situ. The evolution of dihydrogen was confirmed by repeating the experiment in entry 1 with 2 mmol of alcohol and amine. The reaction flask was connected to a burette with a

water reservoir and 70 mL was collected after 20 h. This corresponds to 3 mmol and the gas was shown to be dihydrogen by GC analysis.

**Mechanism:** The amidation is believed to proceed by formation of the aldehyde and the hemiaminal as depicted in Scheme 1. Esters are not intermediates in the reaction, which was confirmed by treating 2-phenylethyl 2-phenylacetate with benzylamine and catalyst A in refluxing toluene. Under these conditions, the ester was stable and none of the amide in Tables 1–3 was observed. Imines are also highly stable under the reaction conditions, which was confirmed by the reaction of *N*-benzylidene benzylamine with catalyst A in refluxing toluene. No conversion of the imine occurred and this did not change by adding water or by conducting the reaction under a dihydrogen atmosphere.

Imines or reduction products of imines have not been observed as byproducts in any of the experiments in Table 4 regardless of the catalyst being used. This may indicate that the intermediate aldehyde stays coordinated to the ruthenium catalyst and is not released into the reaction mixture. If this is true, an externally added aldehyde may not be able to enter

the catalytic cycle and form the amide. To probe this question a crossover experiment was carried out with *p*-methylbenzyl alcohol (1 equiv) and benzaldehyde (1 equiv), which were reacted with *n*-hexylamine (2 equiv) in the presence of complex **1** (5%) and potassium *tert*-butoxide (10%). Under these conditions, the aldehyde was immediately converted into the imine, whereas the alcohol reacted slowly to form the corresponding imine (and not the amide) with about 50% conversion after 24 h. It appears that the imine from the aldehyde inhibits formation of the amide from the alcohol causing the reaction to slow down and to stop at the imine stage. A new experiment was therefore performed in which benzaldehyde (1 equiv) was added over 3 h to a reaction mixture with *p*-methylbenzyl alcohol (1 equiv), *n*-hexylamine (2 equiv), complex **1** (5%), and potassium *tert*-butoxide

ide (10%). Although the amidation was slow in this case it did not stop and the alcohol was converted into a 6:1 mixture of the amide and the imine with almost complete conversion after 30 h and with 50% conversion after 4 h. Again, the aldehyde reacted immediately to produce the corresponding imine, but in this case, a small amount of *N*-benzyl benzamide was also observed as a byproduct. The ratio between the amide from the alcohol and the aldehyde was 10:1 after both 4 and 30 h. This does not indicate that a crossover takes place to a significant degree and we, therefore, believe the intermediate aldehyde in the amidation stays coordinated to the ruthenium catalyst.

In a previous study, ruthenium 1,3-diisopropylimidazol-2-ylidene complex **4** was converted into the five-membered ruthenacycle **5** by C–H activation of the isopropyl methyl group<sup>[33,34]</sup> (Scheme 3). The reaction was facilitated by hy-

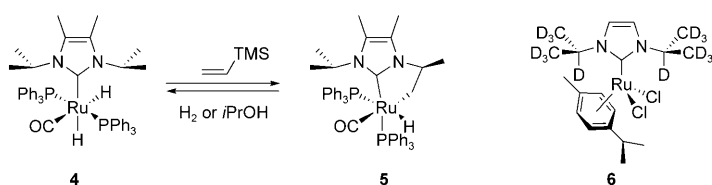

Scheme 3. Interconversion between **4** and **5**<sup>[33]</sup> and the structure of **6**.

drogen acceptors, such as olefins and could be reversed by hydrogen donors, such as dihydrogen or alcohols.<sup>[33]</sup> It could not be completely excluded that a similar C–H activation would take place with our 1,3-diisopropylimidazol-2-ylidene ligand and thereby explain the high reactivity of this ligand in the amidation. To probe this question experimentally, we prepared deuterated complex **6**. If C–H activation of the isopropyl methyl groups is a major reaction pathway we would expect a significant amount of deuterium in the hydrogen gas from the reaction. However, when equimolar amounts of 2-phenylethanol and benzylamine were treated with **6** (10%), PCy<sub>3</sub> (10%), and KHMDS (15%) in refluxing toluene for 1 h, only a 51:1 ratio of H<sub>2</sub> and H–D was measured by selected ion monitoring. This low amount of H–D does not indicate that a rapid exchange reaction is taking place and, therefore, we do not believe that a C–H oxidative addition reaction is involved in the catalytic cycle. The high reactivity of the 1,3-diisopropyl- and 1,3-dicyclohexylimidazol-2-ylidene ligands is probably a result of the relatively low steric demand of these ligands relative to other N-heterocyclic carbene ligands.<sup>[35]</sup> Furthermore, in ruthenium(II) complexes with these ligands agostic interactions have been observed between ruthenium and the CH<sub>2</sub>/CH<sub>3</sub> hydrogen atoms on the ligand that may serve to further stabilize coordinatively unsaturated species in the catalytic cycle.<sup>[36]</sup>

Based on these studies, we propose the reaction mechanism in Scheme 4. The transformation is initiated by loss of the *p*-cymene ligand upon heating. Reaction with an alkoxide followed by  $\beta$ -hydride elimination affords aldehyde com-

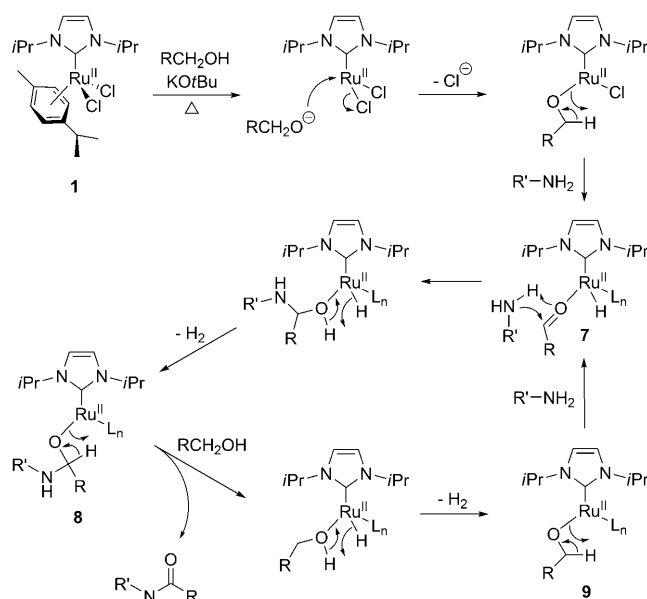

Scheme 4. Proposed mechanism for amide formation.

plex **7**. This part is similar to what has been established for ruthenium transfer hydrogenation catalysts.<sup>[37,38]</sup> It should, however, be noted that [RuCl<sub>2</sub>(PPh<sub>3</sub>)<sub>3</sub>] is known to react with alcohols under basic conditions to form the dihydride complex [RuH<sub>2</sub>(PPh<sub>3</sub>)<sub>3</sub>].<sup>[38]</sup> Whether complex **1** also reacts twice with the alkoxide is not known at this point. In fact, the remaining ligand(s) on ruthenium in **7** could be chloride, hydride, or an amine and is, therefore, denoted L<sub>n</sub> in Scheme 4. A more thorough mechanistic study will have to be carried out to differentiate between these scenarios. With formation of the aldehyde complex **7** a catalytic cycle can be proposed for which the amine adds to the aldehyde to form the hemiaminal, which stays coordinated to the metal. Release of hydrogen can take place by hydrogen transfer to hydride as previously established.<sup>[39]</sup> This gives rise to complex **8**, which upon  $\beta$ -hydride elimination releases the amide. Coordination of the alcohol and a second hydrogen transfer to hydride affords the alkoxide complex **9**, which is ready to re-enter the catalytic cycle. It should be noted that all the ruthenium species in the catalytic cycle remain in the same oxidation state as the starting complex. The added phosphine presumably stabilizes catalyst resting states and is not believed to be involved in the catalytic cycle since the amidation can be performed with a variety of phosphines and other ligands.<sup>[19]</sup>

## Conclusion

In summary, we have presented an atom-economical procedure for the direct synthesis of amides from alcohols and amines in which dihydrogen is formed as the only byproduct. The reaction is catalyzed by ruthenium N-heterocyclic carbene complexes that are easy to handle and straightfor-



ward to modify. Three different catalyst systems have been developed that show similar reactivity and yields in the amidation with a wide variety of substrates. A mechanism is proposed with ruthenium(II) N-heterocyclic carbene species as the catalytically active components and for which the intermediate aldehyde and hemiaminal remain coordinated to ruthenium in the catalytic cycle. The reaction presents a new direction in the synthesis of one of the most important linkages in organic chemistry.

## Experimental Section

**General:** Toluene was distilled from sodium and benzophenone under a nitrogen atmosphere. NMR spectra were recorded on a Varian Mercury 300 Bruker AC 200 spectrometer while IR spectra were obtained on a Bruker alpha-P spectrometer. Mass spectrometry was performed by direct inlet on a Shimadzu-GCMS-QP5000 instrument of for hydrogen analysis on a Pfeiffer OmniStar GSD 301. GC yields were obtained with dodecane as internal standard on a Shimadzu GC-2010 instrument equipped with a Supelco Equity-1 capillary column (15 mm × 0.10 mm, 0.10 μm film). Microanalyses were obtained at the Microanalytical Laboratory, University of Vienna.

**General procedure for amidation with an in situ catalyst (catalyst A):** [RuCl<sub>2</sub>(cod)] (7.0 mg, 0.025 mmol), PCy<sub>3</sub>·HBF<sub>4</sub><sup>[21]</sup> (8.2 mg, 0.025 mmol), 1,3-diisopropylimidazolium chloride (4.7 mg, 0.025 mmol), and KOtBu (11.2 mg, 0.10 mmol) were placed in an oven-dried Schlenk tube. Vacuum was applied and the tube was then filled with argon (repeated twice). Freshly distilled toluene (1 mL) was added and the mixture was heated to reflux under an argon atmosphere for 20 min. The alcohol (0.5 mmol) and the amine (0.5 mmol) were added and the mixture was heated to reflux under an argon atmosphere for 24 h. The reaction mixture was cooled to room temperature and the solvent removed in vacuo. The residue was purified by silica-gel column chromatography (pentane/EtOAc 4:1 → 1:1) to afford the amide.

**[RuCl<sub>2</sub>(iPr)(p-cymene)] (1):** 1,3-Diisopropylimidazolium chloride (124.1 mg, 0.77 mmol) and Ag<sub>2</sub>O (75.3 mg, 0.33 mmol) were suspended in anhydrous, degassed CH<sub>2</sub>Cl<sub>2</sub> (7 mL) under argon and refluxed for 1 h in a Schlenk flask with a reflux condenser. [RuCl<sub>2</sub>(p-cymene)]<sub>2</sub> (201.0 mg, 0.33 mmol) in anhydrous, degassed CH<sub>2</sub>Cl<sub>2</sub> (3 mL) was then added and the solution was refluxed for 2 h and concentrated in vacuo. The residue was purified on a short silica-gel column (CH<sub>2</sub>Cl<sub>2</sub>/iPrOH 9:1) to give 295.0 mg (98%) of a red/orange solid. R<sub>f</sub> = 0.64 (CH<sub>2</sub>Cl<sub>2</sub>/iPrOH 9:1); IR (neat):  $\tilde{\nu}$  = 3152, 3099, 3077, 2958, 2930, 2870, 1473, 1412, 1391, 1369, 1297, 1265, 1213, 1133, 856, 770, 700 cm<sup>-1</sup>; <sup>1</sup>H NMR (300 MHz, CDCl<sub>3</sub>):  $\delta$  = 1.31 (d, J = 6.9 Hz, 6H), 1.44 (br d, J = 6.2 Hz, 12H), 2.08 (s, 3H), 2.92 (m, 1H), 5.15 (d, J = 6.0 Hz, 2H), 5.31 (m, 2H), 5.47 (d, J = 6.0 Hz, 2H), 7.07 ppm (s, 2H); <sup>13</sup>C NMR (75 MHz, CDCl<sub>3</sub>):  $\delta$  = 18.6, 22.8, 25.0, 30.8, 52.0, 83.4, 85.1, 97.1, 106.4, 118.9, 171.1 ppm; MS: m/z: calcd: 423.11 [M-Cl]<sup>+</sup>; found: 423.07; elemental analysis calcd (%) for C<sub>19</sub>H<sub>30</sub>Cl<sub>2</sub>N<sub>2</sub>Ru: C 49.78, H 6.60, N 6.11; found: C 49.84, H 6.44, N 6.05.

**[RuCl<sub>2</sub>(ICy)(p-cymene)] (2):** 1,3-Dicyclohexylimidazolium chloride (200.2 mg, 0.75 mmol) and Ag<sub>2</sub>O (86.1 mg, 0.37 mmol) were suspended in anhydrous, degassed CH<sub>2</sub>Cl<sub>2</sub> (8 mL) under argon and refluxed for 1 h in a Schlenk flask with a reflux condenser. [RuCl<sub>2</sub>(p-cymene)]<sub>2</sub> (226.0 mg, 0.37 mmol) in anhydrous, degassed CH<sub>2</sub>Cl<sub>2</sub> (3 mL) was then added and the solution was refluxed for 1 h and concentrated in vacuo. The residue was purified on a short silica-gel column (CH<sub>2</sub>Cl<sub>2</sub>/iPrOH 9:1) to give 368.4 mg (93%) of a red/orange solid. R<sub>f</sub> = 0.64 (CH<sub>2</sub>Cl<sub>2</sub>/iPrOH 9:1); IR (neat):  $\tilde{\nu}$  = 3091, 2957, 2921, 2848, 1466, 1455, 1446, 1418, 1380, 1290, 1276, 1232, 1190, 897, 747, 697 cm<sup>-1</sup>; <sup>1</sup>H NMR (300 MHz, CDCl<sub>3</sub>):  $\delta$  = 1.14–2.44 (m, 20H), 1.36 (d, J = 6.9 Hz, 6H), 2.13 (s, 3H), 2.84 (m, 1H), 4.84 (m, 2H), 5.14 (d, J = 6.0 Hz, 2H), 5.46 (d, J = 6.0 Hz, 2H), 7.04 ppm (s, 2H); <sup>13</sup>C NMR (50 MHz, CDCl<sub>3</sub>):  $\delta$  = 18.8, 23.1, 25.3, 25.4, 26.0, 31.2, 35.4, 35.8, 59.3, 83.6, 85.3, 97.3, 105.1, 119.3, 171.4 ppm; MS: m/z: calcd: 503.18 [M-Cl]<sup>+</sup>; found: 503.15; elemental analysis calcd (%) for

C<sub>25</sub>H<sub>38</sub>Cl<sub>2</sub>N<sub>2</sub>Ru: C 55.75, H 7.11, N 5.20; found: C 55.14, H 6.84, N 5.16; <sup>1</sup>H NMR spectroscopic data are in accordance with literature values.<sup>[24c]</sup>

**General procedure for amidation with complex 1 (catalyst B):** [RuCl<sub>2</sub>(iPr)(p-cymene)] (1) (11.5 mg, 0.025 mmol), PCy<sub>3</sub> (7.0 mg, 0.025 mmol), and KOtBu (5.6 mg, 0.05 mmol) were placed in an oven-dried Schlenk tube. Vacuum was applied and the tube was then filled with argon (repeated twice). Freshly distilled toluene (1 mL) was added and the mixture was heated to reflux under an argon atmosphere for 20 min. The alcohol (0.5 mmol) and the amine (0.5 mmol) were added and the mixture was heated to reflux under an argon atmosphere for 24 h and then worked up as described above.

**General procedure for amidation with metathesis catalyst (catalyst C):** Hoveyda–Grubbs 1st-generation catalyst (15 mg, 0.025 mmol), 1,3-diisopropylimidazolium chloride (4.7 mg, 0.025 mmol), and KOtBu (8.4 mg, 0.075 mmol) were placed in an oven-dried Schlenk tube. Vacuum was applied and the tube was then filled with argon (repeated twice). Freshly distilled toluene (1 mL) was added and the mixture was heated to reflux under an argon atmosphere for 20 min. The alcohol (0.5 mmol) and the amine (0.5 mmol) were added and the mixture was heated to reflux under an argon atmosphere for 24 h and then worked up as described above.

## Acknowledgements

We thank the Torkil Holm Foundation and the Danish National Research Foundation for financial support.

- [1] a) T. Cupido, J. Tulla-Puche, J. Spengler, F. Albericio, *Curr. Opin. Drug Discovery Dev.* **2007**, *10*, 768–783; b) J. S. Carey, D. Laffan, C. Thomson, M. T. Williams, *Org. Biomol. Chem.* **2006**, *4*, 2337–2347; c) M. Okada, *Prog. Polym. Sci.* **2002**, *27*, 87–133.
- [2] C. A. G. N. Montalbetti, V. Falque, *Tetrahedron* **2005**, *61*, 10827–10852.
- [3] a) R. M. Al-Zoubi, O. Marion, D. G. Hall, *Angew. Chem.* **2008**, *120*, 2918–2921; *Angew. Chem. Int. Ed.* **2008**, *47*, 2876–2879; b) T. Maki, K. Ishihara, H. Yamamoto, *Tetrahedron* **2007**, *63*, 8645–8657.
- [4] J. W. Comerford, J. H. Clark, D. J. Macquarrie, S. W. Breeden, *Chem. Commun.* **2009**, 2562–2564.
- [5] E. Valeur, M. Bradley, *Chem. Soc. Rev.* **2009**, *38*, 606–631.
- [6] a) D. Gnanamgari, R. H. Crabtree, *Organometallics* **2009**, *28*, 922–924; b) N. A. Owston, A. J. Parker, J. M. J. Williams, *Org. Lett.* **2007**, *9*, 3599–3601.
- [7] a) M. B. Soellner, B. L. Nilsson, R. T. Raines, *J. Am. Chem. Soc.* **2006**, *128*, 8820–8828; b) F. L. Lin, H. M. Hoyt, H. van Halbeek, R. G. Bergman, C. R. Bertozzi, *J. Am. Chem. Soc.* **2005**, *127*, 2686–2695.
- [8] a) K. Ekoue-Kovi, C. Wolf, *Chem. Eur. J.* **2008**, *14*, 6302–6315; b) W.-J. Yoo, C.-J. Li, *J. Am. Chem. Soc.* **2006**, *128*, 13064–13065.
- [9] J. W. Bode, R. M. Fox, K. D. Baucom, *Angew. Chem.* **2006**, *118*, 1270–1274; *Angew. Chem. Int. Ed.* **2006**, *45*, 1248–1252.
- [10] a) S. Lang, J. A. Murphy, *Chem. Soc. Rev.* **2006**, *35*, 146–156; b) R. V. Kolakowski, N. Shangguan, R. R. Sauer, L. J. Williams, *J. Am. Chem. Soc.* **2006**, *128*, 5695–5702.
- [11] W. Ye, J. Mo, T. Zhao, B. Xu, *Chem. Commun.* **2009**, 3246–3248.
- [12] a) J. W. Bode, S. S. Sohn, *J. Am. Chem. Soc.* **2007**, *129*, 13798–13799; b) H. U. Vora, T. Rovis, *J. Am. Chem. Soc.* **2007**, *129*, 13796–13797.
- [13] a) A. Brennfürer, H. Neumann, M. Beller, *Angew. Chem.* **2009**, *121*, 4176–4196; *Angew. Chem. Int. Ed.* **2009**, *48*, 4114–4133; b) A. Brennfürer, H. Neumann, M. Beller, *ChemCatChem* **2009**, *1*, 28–41; c) Y. Uenoyama, T. Fukuyama, O. Nobuta, H. Matsubara, I. Ryu, *Angew. Chem.* **2005**, *117*, 1099–1102; *Angew. Chem. Int. Ed.* **2005**, *44*, 1075–1078.
- [14] a) A. J. A. Watson, A. C. Maxwell, J. M. J. Williams, *Org. Lett.* **2009**, *11*, 2667–2670; b) T. Zweifel, J.-V. Naubron, H. Grützmacher,

- Angew. Chem.* **2009**, *121*, 567–571; *Angew. Chem. Int. Ed.* **2009**, *48*, 559–563.
- [15] For the synthesis of amides from primary alcohols and hydroxylamine in the presence of styrene, see: N. A. Owston, A. J. Parker, J. M. J. Williams, *Org. Lett.* **2007**, *9*, 73–75.
- [16] C. Gunanathan, Y. Ben-David, D. Milstein, *Science* **2007**, *317*, 790–792.
- [17] L. U. Nordstrøm, H. Vogt, R. Madsen, *J. Am. Chem. Soc.* **2008**, *130*, 17672–17673.
- [18] K.-i. Shimizu, K. Ohshima, A. Satsuma, *Chem. Eur. J.* **2009**, *15*, 9977–9980.
- [19] See also: S. C. Ghosh, S. Muthaiah, Y. Zhang, X. Xu, S. H. Hong, *Adv. Synth. Catal.* **2009**, *351*, 2643–2649.
- [20] The following imidazolium salts gave low yields in the amidation with PCy<sub>3</sub>: 1,3-bis(2,6-diisopropylphenyl)imidazolium chloride, 1,3-diisopropyl-4,5-dimethylimidazolium chloride, 1,3-diisopropylbenzimidazolium bromide, and 1,3-dibenzylimidazolium bromide.
- [21] J. Zhou, G. C. Fu, *J. Am. Chem. Soc.* **2003**, *125*, 12527–12530.
- [22] V. Dragutan, I. Dragutan, L. Delaude, A. Demonceau, *Coord. Chem. Rev.* **2007**, *251*, 765–794.
- [23] L. Delaude, S. Delfosse, A. Richel, A. Demonceau, A. F. Noels, *Chem. Commun.* **2003**, 1526–1527.
- [24] a) L. Jafarpour, J. Huang, E. D. Stevens, S. P. Nolan, *Organometallics* **1999**, *18*, 3760–3763; b) H. Küçükbay, B. Cetinkaya, S. Guesmi, P. H. Dixneuf, *Organometallics* **1996**, *15*, 2434–2439; c) W. A. Herrmann, C. Köcher, L. J. Gooßen, G. R. J. Artus, *Chem. Eur. J.* **1996**, *2*, 1627–1636.
- [25] a) P. Csabai, F. Joó, *Organometallics* **2004**, *23*, 5640–5643; b) H. M. J. Wang, I. J. B. Lin, *Organometallics* **1998**, *17*, 972–975.
- [26] J. Louie, C. W. Bielawski, R. H. Grubbs, *J. Am. Chem. Soc.* **2001**, *123*, 11312–11313.
- [27] For a recent review on nonmetathesis reactions with Grubbs ruthenium carbenes, see: B. Alcaide, P. Almendros, A. Luna, *Chem. Rev.* **2009**, *109*, 3817–3858.
- [28] I. C. Stewart, T. Ung, A. A. Pletnev, J. M. Berlin, R. H. Grubbs, Y. Schrodi, *Org. Lett.* **2007**, *9*, 1589–1592.
- [29] A. Fürstner, O. Guth, A. Düffels, G. Seidel, M. Liebl, B. Gabor, R. Mynott, *Chem. Eur. J.* **2001**, *7*, 4811–4820.
- [30] The following 1,3-dialkylimidazolium salts were tested in the presence of Grubbs 1st-generation catalyst and base: alkyl = Me, *t*Bu, Mes, *o*-Tol, and *p*-Tol.
- [31] T. Weskamp, F. J. Kohl, W. A. Herrmann, *J. Organomet. Chem.* **1999**, *582*, 362–365.
- [32] The following primary amines were investigated: glycine *tert*-butyl ester, glycylamide, and *N*-benzylglycylamide.
- [33] S. Burling, B. M. Paine, D. Nama, V. S. Brown, M. F. Mahon, T. J. Prior, P. S. Pregosin, M. K. Whittlesey, J. M. J. Williams, *J. Am. Chem. Soc.* **2007**, *129*, 1987–1995.
- [34] For a similar observation with a 1,3-dicyclohexylimidazol-2-ylidene ruthenium complex, see: A. E. W. Ledger, M. F. Mahon, M. K. Whittlesey, J. M. J. Williams, *Dalton Trans.* **2009**, 6941–6947.
- [35] R. Dorta, E. D. Stevens, N. M. Scott, C. Costabile, L. Cavallo, C. D. Hoff, S. P. Nolan, *J. Am. Chem. Soc.* **2005**, *127*, 2485–2495.
- [36] a) S. Burling, E. Mas-Marzá, J. E. V. Valpuesta, M. F. Mahon, M. K. Whittlesey, *Organometallics* **2009**, *28*, 6676–6686; b) S. Burling, G. Kociok-Köhn, M. F. Mahon, M. K. Whittlesey, J. M. J. Williams, *Organometallics* **2005**, *24*, 5868–5878.
- [37] a) E. Solari, S. Gauthier, R. Scopelliti, K. Severin, *Organometallics* **2009**, *28*, 4519–4526; b) B. Martín-Matute, J. B. Åberg, M. Edin, J.-E. Bäckvall, *Chem. Eur. J.* **2007**, *13*, 6063–6072.
- [38] A. Aranyos, G. Csajnyik, K. J. Szabó, J.-E. Bäckvall, *Chem. Commun.* **1999**, 351–352.
- [39] S. L. Chatwin, M. G. Davidson, C. Doherty, S. M. Donald, R. F. R. Jazsar, S. A. Macgregor, G. J. McIntyre, M. F. Mahon, M. K. Whittlesey, *Organometallics* **2006**, *25*, 99–110.

Received: March 4, 2010  
Published online: April 30, 2010