

Engineering Conferences International ECI Digital Archives

Vaccine Technology VII

Proceedings

6-17-2018

Membrane chromatography cassettes for bind and elute applications of viruses and large proteins

Stefan Fischer-Frühholz

Sartorius Stedim Biotech, France, Stefan.Fischer-Fruehholz@Sartorius-Stedim.com

Martin Leuthold

Sartorius Stedim Biotech, France

Stefan Weisshaar

Sartorius Stedim Biotech, France

Florian Taft

Sartorius Stedim Biotech, France

Miyako Hirai

Sartorius Stedim Biotech, France

See next page for additional authors

Follow this and additional works at: http://dc.engconfintl.org/vt_vii

 Part of the [Engineering Commons](http://dc.engconfintl.org/vt_vii)

Recommended Citation

Stefan Fischer-Frühholz, Martin Leuthold, Stefan Weisshaar, Florian Taft, Miyako Hirai, and Amélie Boulais, "Membrane chromatography cassettes for bind and elute applications of viruses and large proteins" in "Vaccine Technology VII", Amine Kamen, McGill University Tarit Mukhopadhyay, University College London Nathalie Garcon, Bioaster Charles Lutsch, Sanofi Pasteur Eds, ECI Symposium Series, (2018). http://dc.engconfintl.org/vt_vii/76

This Abstract and Presentation is brought to you for free and open access by the Proceedings at ECI Digital Archives. It has been accepted for inclusion in Vaccine Technology VII by an authorized administrator of ECI Digital Archives. For more information, please contact franco@bepress.com.

Authors

Stefan Fischer-Frühholz, Martin Leuthold, Stefan Weisshaar, Florian Taft, Miyako Hirai, and Amélie Boulais

Membrane Chromatography Cassettes for Bind & Elute Applications of Viruses and Large Proteins

Fischer-Fruehholz, S., Leuthold, M., Weisshaar, S., Taft, F., Hirai, M.
 Sartorius Stedim Biotech GmbH, August-Spindler-Str. 11, D-37079 Goettingen, Germany.
 Vaccine Technology VII, Engineering Conferences International, Fairmont Tremblant, Mont Tremblant, Quebec, Canada, June 17 – 22, 2018

1. Introduction

For flow-through polishing applications membrane adsorbers have become a well-established technology. However, there is an increasing demand for bind and elute purifications for larger targets as adeno- and lentiviruses, virus like particles (VLP) and influenza.¹ The reason is the higher binding capacity of macroporous membranes compared to conventional resins having much smaller pores and excluding them by size.

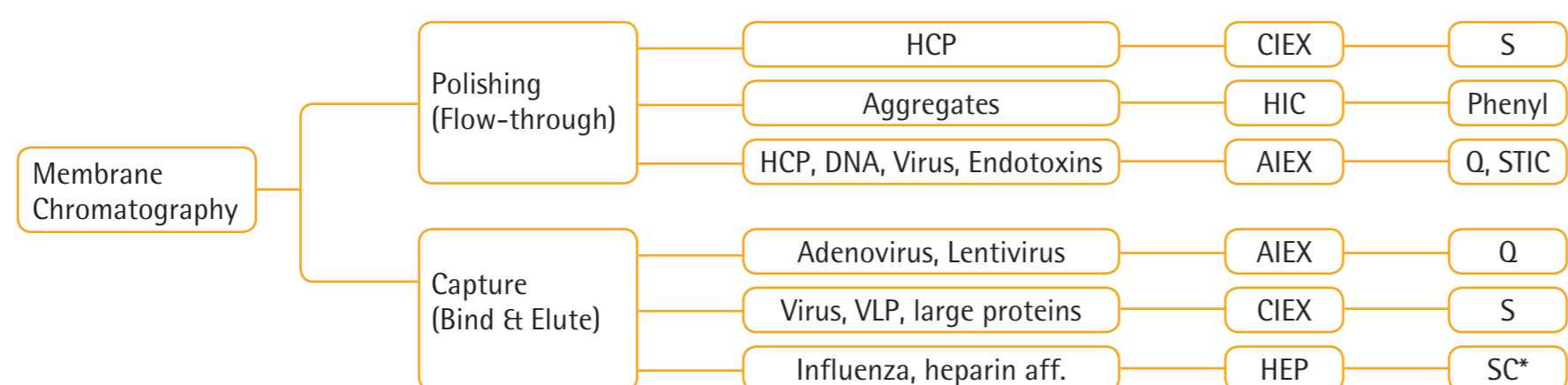

Figure 1: Typical modes of operations and applications for membrane adsorbers in the biopharmaceutical industry. Ligands: S = sulfonic acid for cation exchange (CIEX), Phenyl as hydrophobic interaction chromatography ligand (HIC), Q = quaternary ammonium, STIC = STIC PA primary amine (salt tolerant) for anion exchange (AIEX), SC = sulfated cellulose (*) prototype, heparine pseudo affinity (HEP)

But capture applications with such devices suffered from the current size limitation of 5 liters e.g. in the Sartobind® Q or S Jumbo 5 L. (Fig. 2a) Here we describe a modular cassette system which has been tested for scale-up and flow performance in comparison with void volume optimized capsules. The goals were to create a system up to 20 L membrane volume which can be optionally expanded to ~100 liter and, be able adapt exactly to the size needed (modular), using the same 4 and 8 mm bed height as the capsules and membranes for single- or intra batch re-use.

2. The cassette design: 2 membrane stacks 4 | 8 mm

In capsules the membrane is rolled up. To achieve the same flow pattern in the cassette, a cut through a capsule suggests two stacks of membrane with a central inlet flow channel. The fluid enters on top between the stacks and travels through these to the outside (downstream) channels and then to the outlet (Fig. 2b). By this design approach the principal fluid path is maintained.



Figure 2a: Sartobind® Jumbo 5 L as largest adsorber size

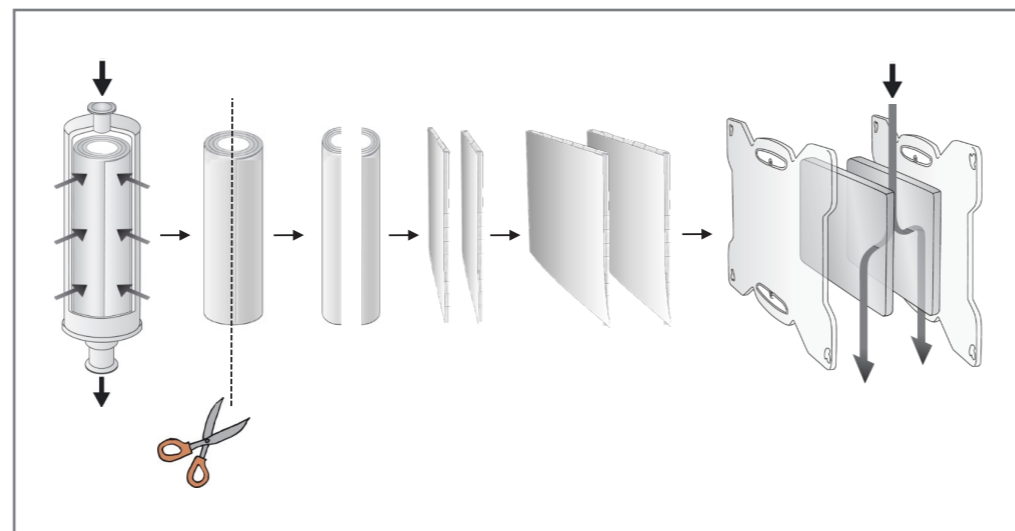

Figure 2b: Design for the cassette is derived from the capsule by cutting and creating two membrane stacks.

Figure 3 shows the realized cassette with a size of 634 × 387 × 47 mm and a dry weight of 4.9 kg (6.0 kg wet). The cassette can be assembled in a pilot filter holder which accommodates up to 13 cassettes (20.8 L, Fig. 4c) and are run with one manifold feeding the liquid in the upstream distribution channels and one manifold of the downstream channel (Fig. 4a). A process holder has been designed for up to ~100 L membrane (Fig 4b).

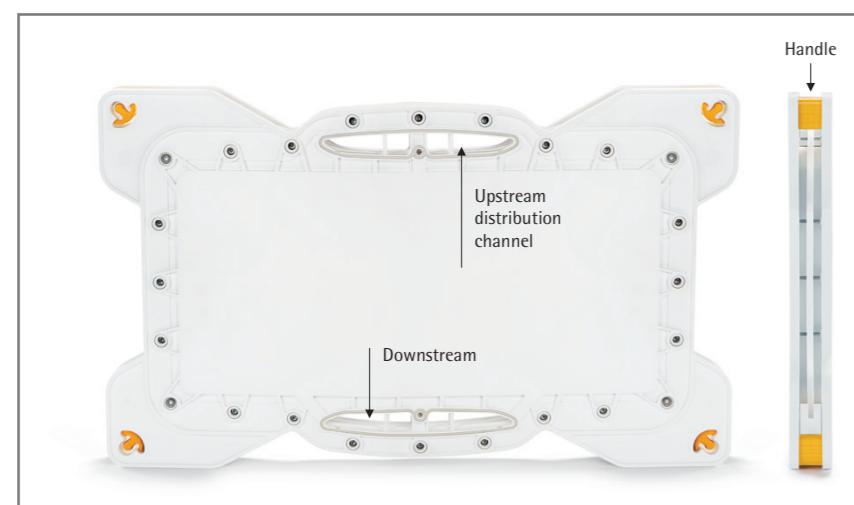

Figure 3: Design of Sartobind® Cassette

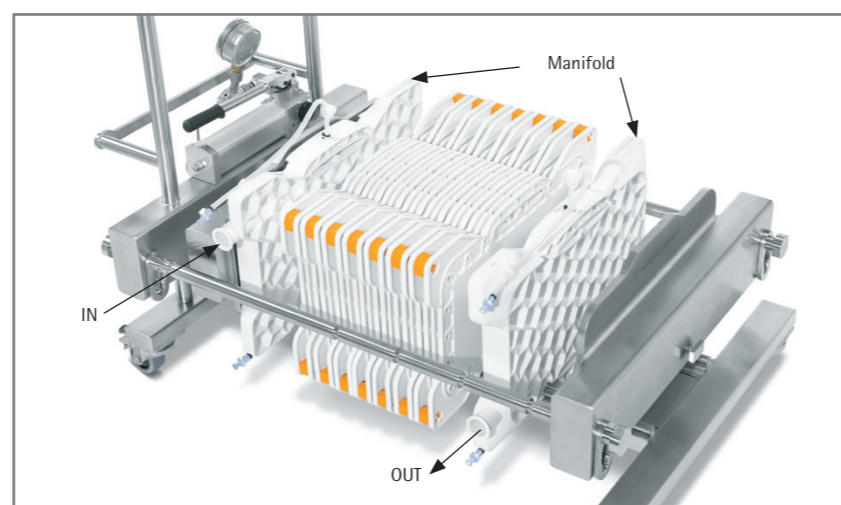

Figure 4a: Symmetrical manifolds at both ends of cassette pack are needed to connect the setup to a chromatography skid

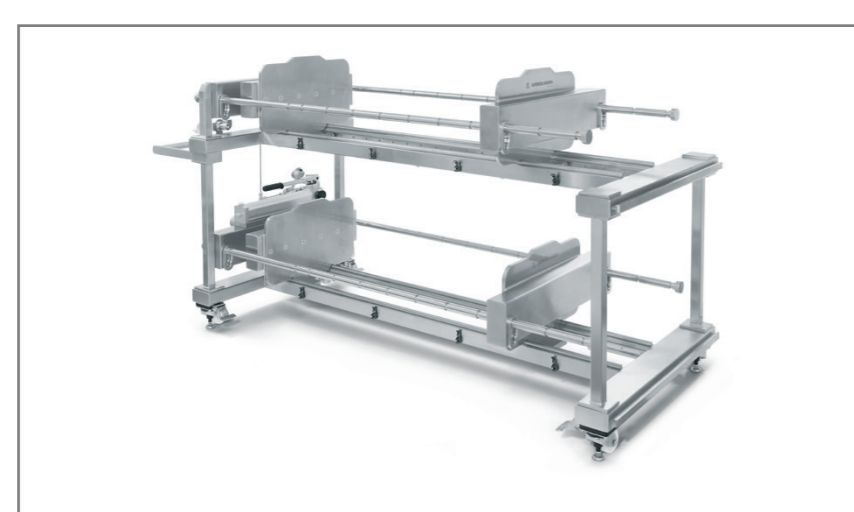

Figure 4b: 100 L Process Holder

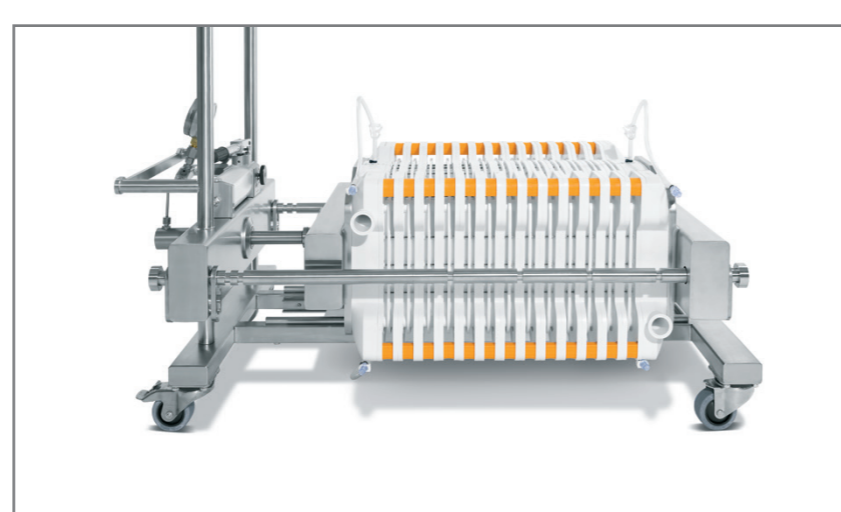

Figure 4c: 13 Cassettes (20.8 L) in the Pilot Filter Holder

Bed height	Nano mL	5" mL	10" mL	20" mL	30" mL	Jumbo mL	Cassette mL
4 mm	1	75	200	400	600	2500	800
8 mm	3	150	400	800	1200	5000	1600

Table 1: Existing Sartobind® membrane chromatography capsule portfolio with 4 mm and 8 mm bed height and Cassette membrane volumes

3. Comparison of capsule and cassette fluid paths

Figure 5 shows the construction of the standard membrane adsorber devices in the 4 and 8 mm void volume optimized design. In the cassette (Fig. 6) the same flow principle is applied as in the existing capsules as feed flows perpendicular through the membrane and through void volume optimized fluid channels.

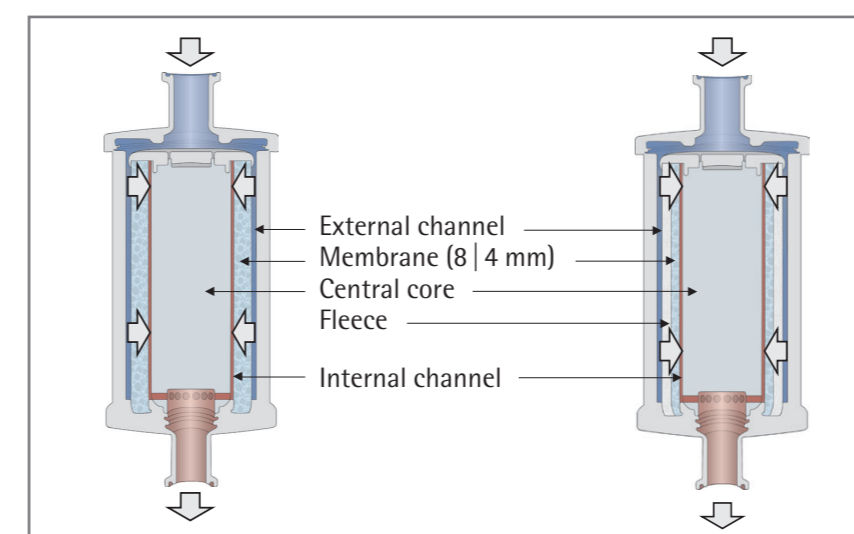

Figure 5: Design and flow path of void volume optimized adsorber capsules in 8 mm (left) and 4 mm (right) bed height.

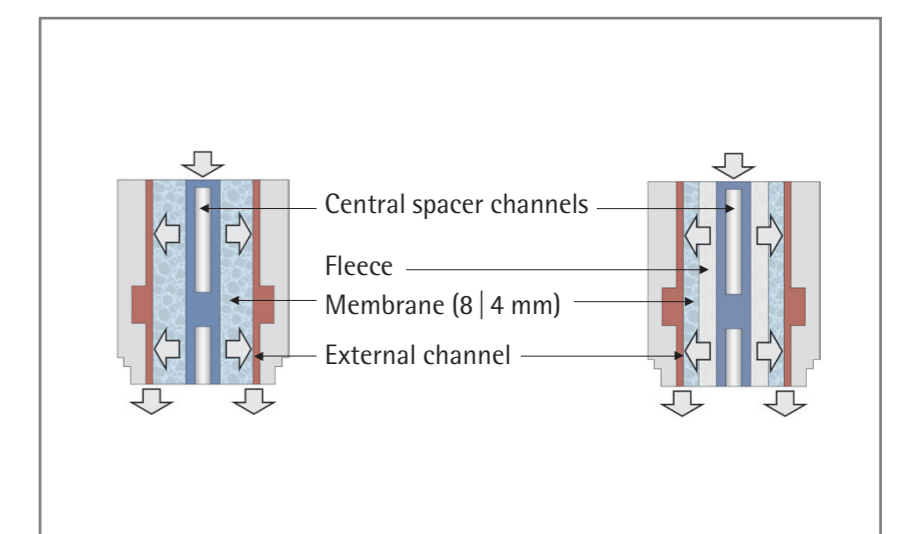

Figure 6: Design and flow path of void volume optimized adsorber cassettes in 8 mm (left) and 4 mm (right) bed height.

4. Scaleability

The scale-up from existing adsorber capsules to cassettes is essential.

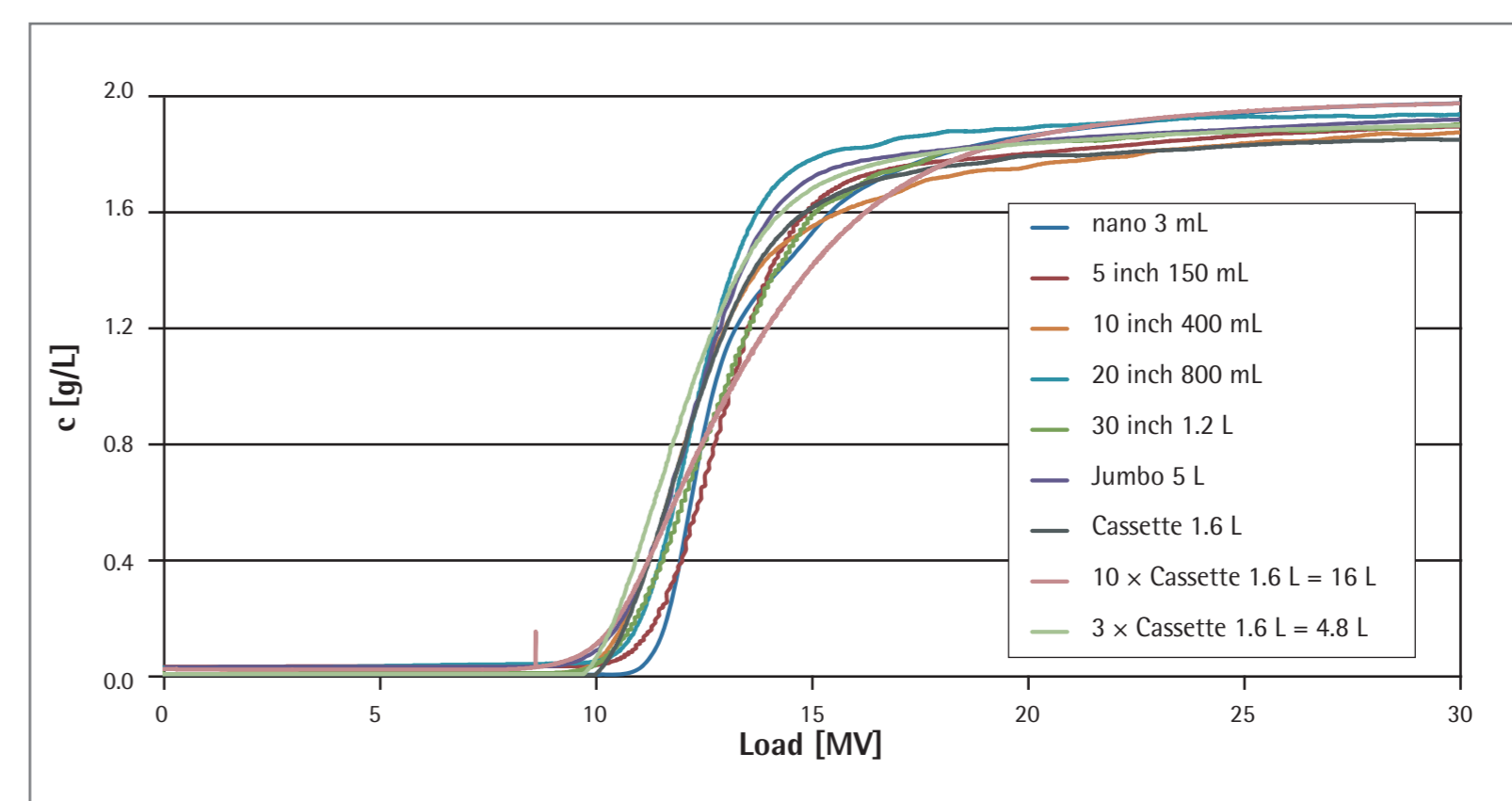
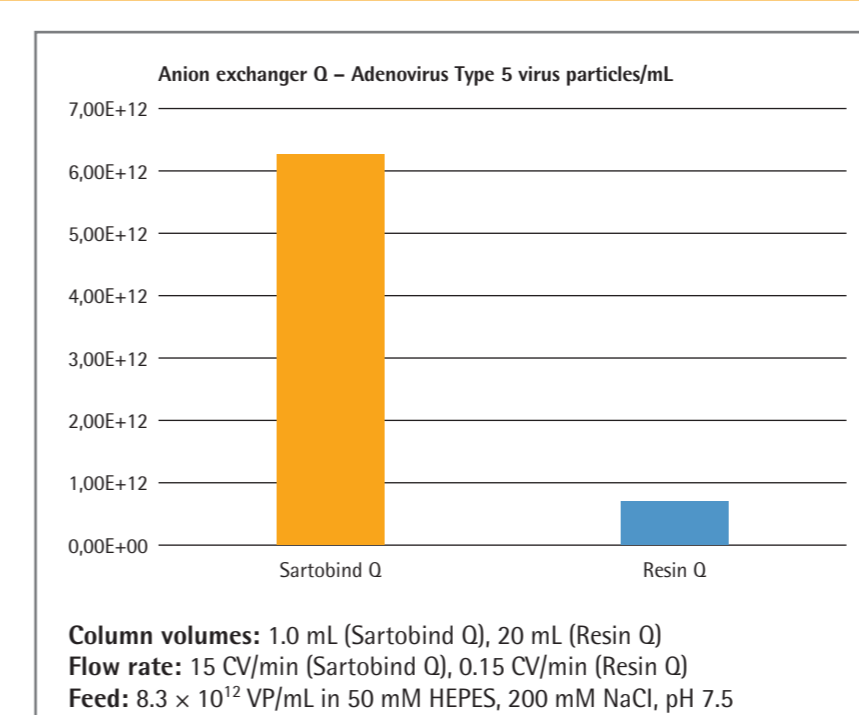

Figure 7: BSA breakthrough curves of void volume optimized capsules and single, 3 × 1.6 L cassette and 10 × 1.6 L cassette, 8 mm bed height versions.

To compare breakthrough performance, devices were loaded with a 2 g/L bovine serum albumin (BSA) solution in 20 mM Tris/HCl pH 7.2. The equilibration was performed using 5 MV of equilibration buffer. The flow rate was 5 MV/min. 1.6 L Q Cassette setups displayed the same shape of breakthrough as the optimized capsule product line (Fig. 7).

5. Virus capture on AIEX (Q) and sulfated cellulose (SC) adsorbers vs. resins



Column volumes: 1.0 mL (Sartobind Q), 20 mL (Resin Q)
Flow rate: 15 CV/min (Sartobind Q), 0.15 CV/min (Resin Q)
Feed: 8.3×10^{12} VP/mL in 50 mM HEPES, 200 mM NaCl, pH 7.5

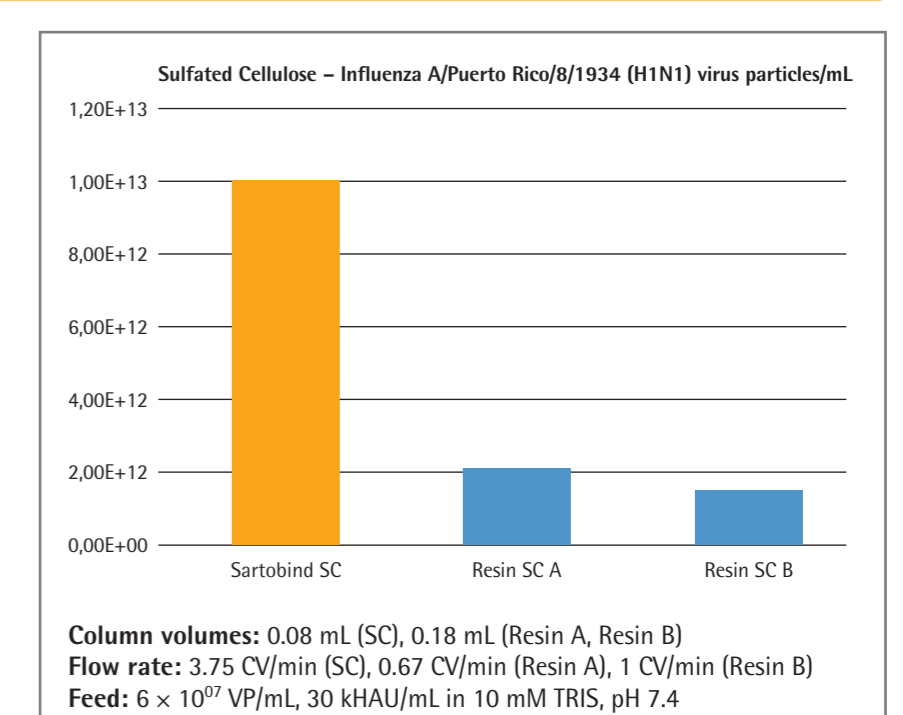

Column volumes: 0.08 mL (SC), 0.18 mL (Resin A, Resin B)
Flow rate: 3.75 CV/min (SC), 0.67 CV/min (Resin A), 1 CV/min (Resin B)
Feed: 6×10^{12} VP/mL, 30 kHAU/mL in 10 mM TRIS, pH 7.4

6. Summary

The Sartobind® Cassette system is a prerequisite for large scale bind & elute membrane chromatography. Combined with anion exchangers and newly developed virus capture membranes such as sulfated cellulose adsorbers it intensifies manufacturing of virus and VLP.

7. References

- (1) Opitz L.: Sulfated membrane adsorbers for economic pseudo-affinity capture of influenza virus particles. Biotechnol Bioeng 2009 103(6), 1144-1154.
- (2) Application Note Sartorius Stedim Biotech: Optimizing Adenovirus Purification Processes, April 2017
- (3) Taft, F., Köhler, R. van Teeffelen, S., Fortuna, A. R., Wolff, M., Reichl, U., Villain, L.: Influenza virus capture using membrane chromatography: Improving selectivity by matrix design and pseudo-affinity ligand interactions, PREP Int. Symposium, Preparative and Process Chromatography, Philadelphia, USA, July 19-20, 2016, poster