

SELECTIVE FRACTIONATION AND DEPOLYMERIZATION OF LIGNOCELLULOSIC BIOMASS USING SUBCRITICAL AND SUPERCRITICAL WATER TO PRODUCE HEMICELLULOSE, CELLULOSE AND LIGNIN

Gianluca Gallina, University of Valladolid
gianluca.gallina87@gmail.com
Juan Garcia-Serna, University of Valladolid
Pierdomenico Biasi, Åbo Akademi
Maria Jose Cocero, University of Valladolid

Key Words: Hemicellulose, Fractionation, Biomass, Hydrothermal hydrolysis.

Cellulose and hemicelluloses contained in woody biomass can be hydrolysed to monomeric sugars, which can be fermented to ethanol, or can be converted into higher value products [1].

Hemicelluloses, when isolated from biomass, have unique properties. They can be used to produce films for packaging applications in substitution to synthetic plastics, as polysaccharides works as barriers against oxygen permeation; another important application is the production of aerogels to insulate products. Xylose from hemicellulose, for instance, can be converted to furfural, which is a precursor used in different fields, such as oil refining, plastics, pharmaceutical, and agrochemical industries. L-Xylose can be also hydrogenated or enzymatically transformed to xylitol, which is a sweetening agent and is also used for preventing tooth decay [2]. The idea of transforming biomass to energy, materials, and chemicals, defines the concept of biorefinery, particularly interesting topic nowadays, considering the issues related to fossil combustibles and derivatives [3-5].

A promising, clean and cheap way to depolymerize cellulose and hemicellulose into monosaccharides is the process called autohydrolysis, which simply consists on treating biomass with hot water/steam.

During the reaction, most of the hemicellulose is extracted and hydrolysed to monomers, with a consequent release of acetic acid originated from the acetyl groups bonded to the oligosaccharides; a less amount of cellulose is released, due to the crystalline structure of the polymer, which make it more difficult to dissolve [6]. In our study, we investigate thoroughly the autohydrolysis of wood coming from different species of trees to produce especially hemicelluloses. The experiments are carried out with different kinds of reactors:

- a laboratory-scale semicontinuous tubular reactor , i.e. biomass wood chips in batch and fresh water pumped in continuous.
- a batch cascade reactor composed by 5 reactors connected in series, with water fully recirculated;
- a continuous reactor with a homogeneous water-sawdust slurry, injected through a pipe together with a high temperature water stream, with low residence times;
- a pilot-scale plant composed by 5 semi-continuous reactors working in series.

Fractionation of biomass from *Eucalyptus globulus*, using subcritical water with a laboratory-scale semicontinuous tubular reactor

Optimal conditions for hemicellulose extraction from wooden biomass in a semi-continuous system have been assessed in this work. This study would constitute the first stage for a profitable and green industrial process. *Eucalyptus globulus* was selected as raw material due to its low water consumption, high growth and its efficiency in lignocellulose production. Moreover its cultivation is very popular southern Europe. Samples of 5g of wood were fractioned using a pressurized hot water semi-continuous system, to produce sugars (pentoses and hexoses) and a solid residue enriched in lignin.

Five flow rates between 2.5 and 20 mL/min and four temperatures between 135 and 285°C were tested in order to maximize the production of sugars, avoiding the formation of degradation products.

Optimum conditions for the extraction of hemicellulose were identified at 185 °C and 5 mL/min, leading to a pentoses yield of 64.7%, with 0.7 of degradation products. Almost all the pulp is extracted at 285 °C.

SEM images show very well the changes in the wood structure at different temperatures.

A kinetic model was developed, describing the extraction and hydrolysis of hemicellulose and cellulose with absolute average deviations around 30 % for sugar concentration.

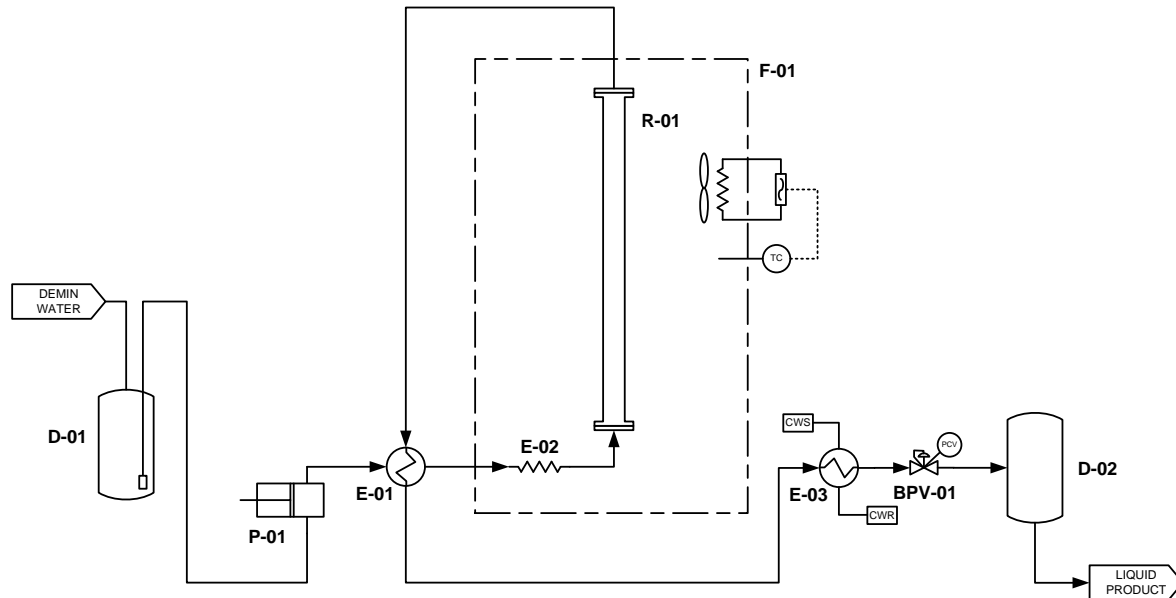

Figure 1. Schematic flow diagram of the experimental system. Equipment: D-01 Feeder, P-01 Pump, E-01 Feed water preheater, R-01 Hydrothermal reactor, F-01 Reactor air convection oven, E-02 Reactor inlet heat exchanger, BPV-01 Product depressurization Go-backpressure valve, E-03 Product cooler, D-02 liquid product vessel.

Study of hemicelluloses composition of different tree species, extraction using subcritical water with a batch cascade reactor.

Hemicelluloses from 10 different tree species commonly growing in the Castilla y Leon region have been extracted with a batch cascade reactor. Raw materials come from tree branches, cut during the seasonal pruning.

The aim is to identify the best species to obtain a high concentration of hemicelluloses, high yield and high molecular weight. The system allows the sampling of both the solid and liquid phases during the reaction. Temperature and pressure of the system are monitored and recorded online inside each reactor chamber. . Experiments were carried out at the same operating conditions: temperature of 160°C, particle size between 1,25 and 2 mm, residence time of 80 min.

Previous works indicates these conditions to be the best to obtain the highest yield of hemicelluloses, with the lowest amount of degradation products [7].

Samples of extracted liquid solution and extracted solid were taken at 5, 10, 20, 40 and 80 min from the beginning of the experiments.

Highest amount of hemicelluloses is contained in trees of genera *Prunus*, highest yield (89%) have been reached from *Acer saccharium* (sugar maple). *Acer saccharium* extracted molecules shows molecular weights up to 60 KDa.

TGA analysis were done in order to associate the extraction yield to the structure of the wood.

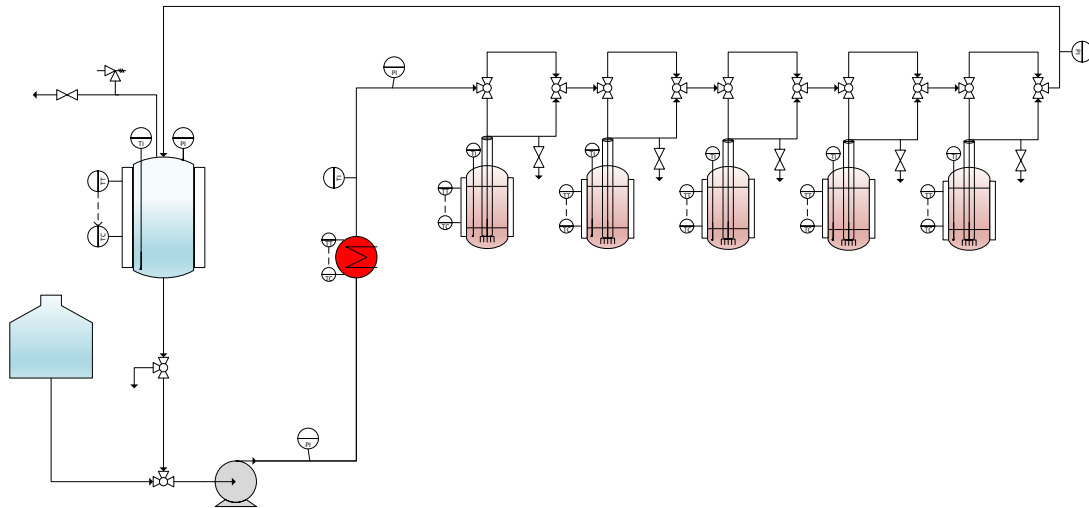

Figure 2. Cascade reactor setup.

Fractionation of woody sawdust using a continuous reactor.

Sawdust produced from carpentry have been collected and sieved in order to obtain powder with a particle size lower than 200 μm . A homogeneous sawdust-water slurry with a concentration 2%, constantly mixed was continuously injected through a pipe, and mixed with a hot water stream. The temperature of the water stream and the length of the pipe have been changed in order to maximize the yield of hemicelluloses, without breaking the cellulose chains. Temperatures between 250 and 300 $^{\circ}\text{C}$ have been chosen, with residence times between 0,8 and 5,5 seconds. The severity factor varies between 2,7 and 4,8. After the extraction, the exhaust solid was filtered from the water solution and passed through the reactor together with a supercritical water stream (400 $^{\circ}\text{C}$ and 250 bar) in order to hydrolyze the cellulose and obtain an exhaust solid rich in lignin. This process allows to selectively separating the three principal biomass components [8].

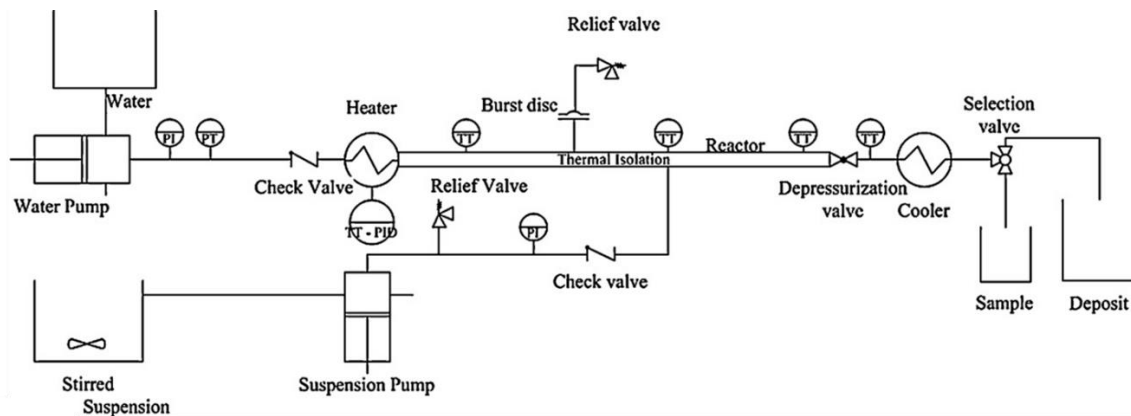

Figure 3. Continuous reactor setup.

Pilot-scale multistage semi-continuous reactor for the extraction of hemicelluloses

A pilot plant extractor composed by 5 semi-continuous reactors working in series was designed and built in order to extract hemicellulose from various kinds of lignocellulosic biomasses. Each reactor has a volume of 1L and it was specifically designed to assure that plug flow is obtained and to recover the final solid in high quality. Operative temperatures are between 100 and 200 $^{\circ}\text{C}$; water is preheated to the desired temperature before entering in the system, moreover each reactor dispose of electric resistances that keep it at a constant and homogeneous temperature. Pressure of the system is maintained by a back-pressure valve, and a kinetic pump provides liquid flowrates until 40 L/h. When the extraction process ends in a reactor, it can be excluded from the system and the flow switched to another unit.

A condenser allows draining the reactor before the removal of the internal cylinder containing the biomass. Once removed, the solids are quenched with cold water and suddenly opened to collect the solid.

pH of the extracted solution is monitored online, allowing to follow the progress of the reaction: since the decrease in pH is directly related to hydrolysis of the hemicellulose oligomers, which leads to liberation of acetic acid.

Heat recovery is implemented in the system: liquid exiting the system warms feeding fresh water, saving the 80% of the energy and cutting cooling water expenses.

This unit operates close to what an industrial context would be; making the scale-up of a process that currently takes place only at a laboratory scale.

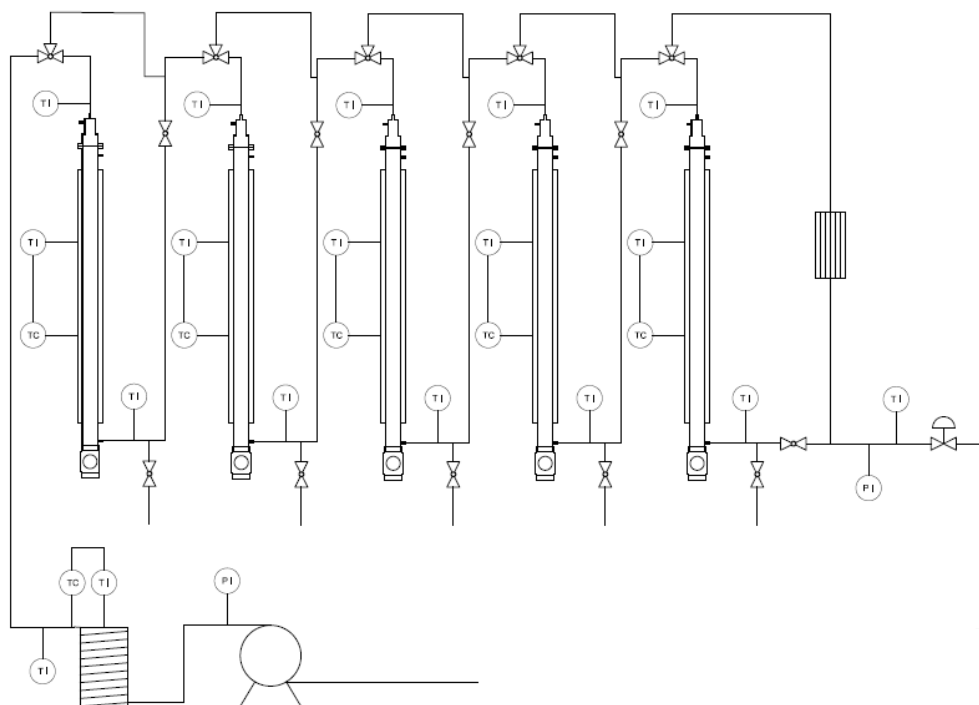

Figure 3. Pilot scale extractor s

Bibliography

- [1] F. Cherubini, The biorefinery concept: Using biomass instead of oil for producing energy and chemicals, *Energy Conversion and Management* 51 (2010) 1412-1421.
- [2] P. Mäki-Arvela, B. Holmbom, T. Salmi, D.Y. Murzin, Recent Progress in Synthesis of Fine and Specialty Chemicals from Wood and Other Biomass by Heterogeneous Catalytic Processes, *Catalysis Reviews: Science and Engineering* 49 (2007) 197 - 340.
- [3] M. González, A. García, A. Toledano, R. Llano-Ponte, M.A. De Andrés, J. Labidi, Lignocellulosic feedstock biorefinery processes. Analysis and design, 2009, pp. 1107-1112.
- [4] T. Salmi, *Chemical Reaction Engineering of Biomass Conversion*, 2013, pp. 195-260.
- [5] J.J. Bozell, G.R. Petersen, Technology development for the production of biobased products from biorefinery carbohydrates-the US Department of Energy's "Top 10" revisited, *Green Chemistry* 12 (2010) 539-554.
- [6] P. Mäki-Arvela, T. Salmi, B. Holmbom, S. Willför, D.Y. Murzin, Synthesis of sugars by hydrolysis of hemicelluloses- A review, *Chemical Reviews* 111 (2011) 5638-5666.
- [7] H. Grenman, K. Eranen, J. Krogell, S. Willför, T. Salmi, D.Y. Murzin, Kinetics of aqueous extraction of hemicelluloses from spruce in an intensified reactor system, *Industrial and Engineering Chemistry Research* 50 (2011) 3818-3828.
- [8] D. Cantero, M.D Bermejo, M.J. Cocero, Kinetic analysis of cellulose depolymerization reactions in near critical water, *The Journal of Supercritical Fluids* 75 (2013) 48– 57.

Acknowledgements

The authors acknowledge the Spanish Economy and Competitiveness Ministry, Project FracBioFuel: ENE2012-33613 and the regional government (Junta de Castilla y León), Project Reference: VA330U13 for funding. MEng. Gianluca Gallina wish to acknowledge the Spanish Economy and Competitiveness Ministry for the scholarship/predoctoral contract.