

Refereed Proceedings

The 13th International Conference on

Fluidization - New Paradigm in Fluidization

Engineering

Engineering Conferences International

Year 2010

DESIGN OF NEW FLUIDIZED BED
REACTORS FOR CVD - PROCESSES

T. Strer*

M. Schober[†]

K.-E. Wirth[‡]

*University of Erlangen-Nuremberg, t.strer@lfg.uni-erlangen.de

[†]University of Erlangen-Nuremberg

[‡]University of Erlangen-Nuremberg

This paper is posted at ECI Digital Archives.

http://dc.engconfintl.org/fluidization_xiii/67

DESIGN OF NEW FLUIDIZED BED REACTORS FOR CVD - PROCESSES

T. Strer, M. Schober, K.-E. Wirth
 Institute of Particle Technology
 University of Erlangen-Nuremberg, 91058 Erlangen, Germany

1. ABSTRACT

A new concept of fluidized bed will be shown which can be used for various gas-to-solids reactions (e.g. chemical vapour deposition (CVD) reactions) with high throughput like the production of new materials. For the design and scale-up of the new bubbling fluidized bed with vertically aligned vertical nozzles the fluid dynamics of the fluidized beds have to be determined and analysed, especially the flow around the gas nozzles. A jet region around a single centrally arranged injector lance in a bubbling fluidized bed reactor is characterized by different parameters like solids concentration and jet gas distribution. It can be shown that – depending on the related parameter – different jet regions are obtained.

2. INTRODUCTION

Bubbling fluidized beds, in which particles are kept in abeyance by a vertically upwards orientated gas stream, have different advantages, which make them interesting for the chemical industry: easy handling of solids due to the liquid like behavior, fast solids mixing leading to nearly isothermal behavior and an intensive particle-fluid-contact, resulting in high material- and heat transfer coefficients (Werther (16)). Surveys of the hydrodynamics of gas-solid-fluidization are given by, e.g. Lim et al. (8) and Yang (18). A possible application of fluidized beds is the use as reactor for CVD-processes. A good overview over such processes gives e.g. Choy (17). In the case of CVD-reactions, viz the deposition of solid material on the surface of particles, the reactant gas is injected into the fluidized bed reactor through nozzles in different number and position.

Many results of investigations from different authors are published up to now, but most of them deal with gas jets in two-dimensional fluidized beds or if the investigations were made in three-dimensional fluidized beds, the diameters of the reactors were very small (Yan (19), Massimilla (4), Merry (2, 3), Wu et al. (5), Copan et al. (13), Kimura et al. (7), Markhevka et al. (1), Hong et al. (9), Musmarra (12), Guo et al. (14), Cleaver et al. (6), Vaccaro (10,11)).

The most important parameters to describe a jet region are the jet penetration depth and the jet angle. Several correlations are published to calculate these two values. The most famous are the correlations of Merry for the penetration height L_{Jet} and the half jet opening angle θ of a vertical gas jet in a fluidized bed (Merry (3)).

Penetration depth of vertical gas jet:

$$\frac{L_{Jet}}{d_0} = 5.2 \cdot \left(\frac{\rho_f \cdot d_0}{\rho_s \cdot d_p} \right)^{0.3} \cdot \left(1.3 \cdot \left(\frac{U_0^2}{g \cdot d_0} \right)^{0.2} - 1 \right) \quad (1.1)$$

Half jet angle of vertical gas jet:

$$\theta = \arctan \cdot \left(\frac{1}{10.4} \cdot \left(\frac{\rho_s \cdot d_p}{\rho_f \cdot d_0} \right)^{0.3} \right) \quad (1.2)$$

The aim of the present paper is to investigate the flow around the nozzles in bubbling fluidized beds of scale which is typical for scale-up experiments. The investigations are focused on the fluid dynamics in a bubbling fluidized bed with centrally aligned vertical injection nozzle.

2. EXPERIMENTAL

The objective of this work was the characterization of a jet region in a bubbling fluidized bed with additional vertical gas injection through a centrally arranged nozzle (see Fig. 1).

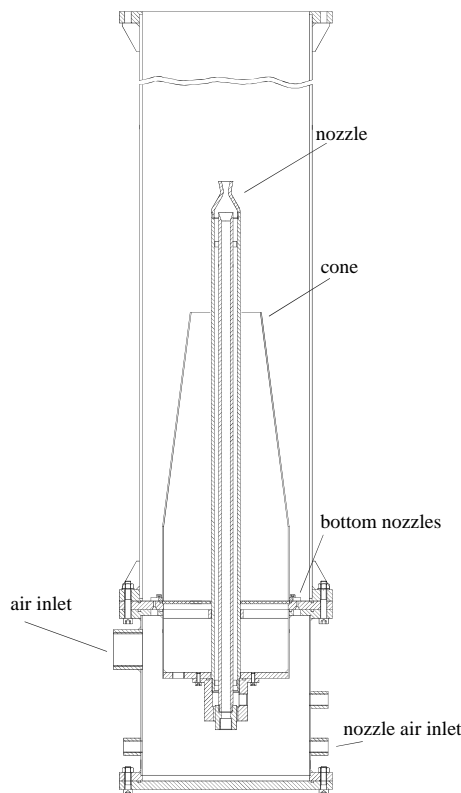

Fig. 1: Fluidized bed reactor model

The fluidized bed reactor model had an inner diameter of 190 mm and a height of 2000 mm. It was made out of plexiglass and in the centre an injector lance with a length of 482 mm was installed. The nozzle on top of the lance had an outlet diameter of 10 mm. To intensify the solids movement in the fluidized bed a conical tube was concentrically installed around the lance (see Fig. 1). The air for fluidizing the solids was applied through 12 bottom nozzles with a diameter of 1.9 mm in the bottom of the reactor outside the cone. The experiments were carried out at ambient conditions. The used solid (fused quartz) had a mean diameter of $d_p = 732 \mu\text{m}$ and a density of $\rho_s = 2480 \text{ kg/m}^3$. The reactor was filled with particles up to a static bed height of 700 mm, thus 220 mm above the

nozzle mouth. All presented results were obtained at a superficial gas velocity of $U_G = 0.46$ m/s and a jet gas velocity of $U_{Jet} = 60.13$ m/s.

In order to measure the secondary gas distribution a mass spectrometer in conjunction with a tracer gas (helium) was used. The helium was added to the air applied through the injector lance and its concentration was measured by the mass spectrometer at different radial and axial positions.

3. RESULTS AND DISCUSSION

In the following, the jet region in a fluidized bed reactor with additional gas injection through a centrally arranged injector lance is characterized by different parameters (solids concentration and jet gas distribution). Contrary to most publications up to now the nozzle mouth is in a relatively large distance from the bottom gas distributor.

3.1 Solid concentration distribution

Radial solids concentration profiles were recorded by using capacitance probes (Richtberg (15)) Fig. 2 shows some measured concentration profiles for a superficial gas velocity of $U_G = 0.46$ m/s and a jet gas velocity of $U_{Jet} = 60.13$ m/s.

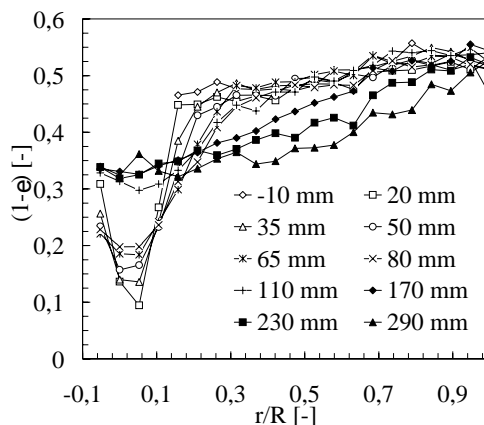

Fig. 2: Radial solids concentration profiles for different axial distances h from the nozzle mouth; $U_G = 0.46$ m/s, $U_{Jet} = 60.13$ m/s, $d_p = 732 \mu\text{m}$, $\rho_S = 2480 \text{ kg/m}^3$, $h_{bed} = 700$ mm

region, a half jet angle of $\theta = 13.7^\circ$ can be calculated (see Fig. 3). This angle is clearly smaller than the calculated angle by means of Merry's correlation (see equation 1.2). The correlation provides a half jet angle of $\theta = 22.8^\circ$.

Merry's correlation for the penetration depth of vertical gas jets in fluidized beds gives a value of $L_{Jet} = 113$ mm (see equation 1.1). Regarding the solids concentration $(1-\epsilon)$ at the radial position $r/R = 0$ the jet penetration depth can be defined to $L_{Jet} = 110$ mm (see Fig. 4).

Above the injector lance at the radial position $r/R = 0$, a jet region with low solids concentration down to $(1-\epsilon) < 0.1$ is formed. With increasing the axial distance h from the nozzle mouth, the solids concentration in the centre of the fluidized bed increases and an increasing radial extension of the jet region can be detected. A value of 80 % of the solids concentration in the suspension close to the reactor wall is assumed to be the boundary of the jet

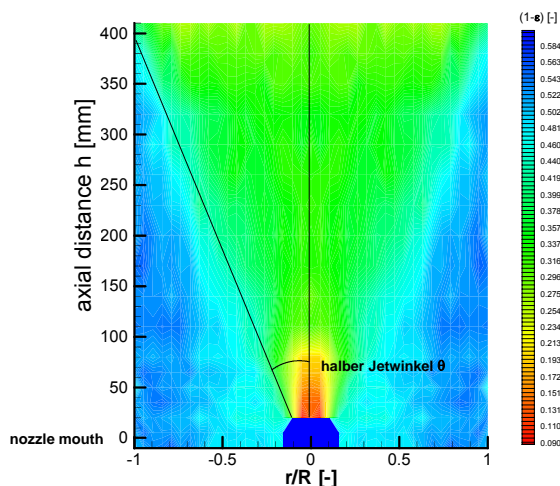

Fig. 3: Solids concentration distribution; $U_G = 0.46$ m/s, $U_{Jet} = 60.13$ m/s, $d_p = 732$ μ m, $\rho_S = 2480$ kg/m³, $h_{bed} = 700$ mm

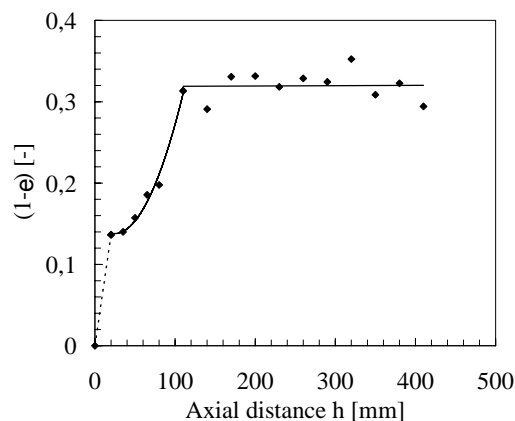

Fig. 4: Solids concentration at the radial position $r/R = 0$ against the axial distance h ; $U_G = 0.46$ m/s, $U_{Jet} = 60.13$ m/s, $d_p = 732$ μ m, $\rho_S = 2480$ kg/m³, $h_{bed} = 700$ mm

Between $h = 20$ mm and $h = 110$ mm a distinct increase in the solids concentration $(1-\epsilon)$ can be detected. Above $h = 110$ mm, the values for the concentration show fluctuations around a value of about $(1-\epsilon) = 0.32$ and no clear tendency is observable. Not only the solids concentration directly in the centre of the bed, but also the mean cross-sectional solids concentration within the jet region, mentioned above ($\theta = 13.7^\circ$), shows the same jet length L_{Jet} (see Fig. 5). The solids concentration outside the jet region is nearly constant over the total investigated axial distance from the nozzle mouth.

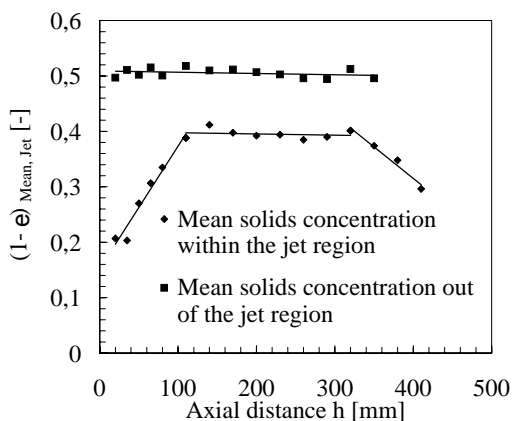

Fig. 5: Dependency of mean solids concentration within and outside the jet region on axial distance h ; $U_G = 0.46$ m/s, $U_{Jet} = 60.13$ m/s, $d_p = 732$ μ m, $\rho_S = 2480$ kg/m³, $h_{bed} = 700$ mm

3.2 Jet gas distribution

Beside the solids concentration, the injected gas (e.g. reactant gas) is of particular interest. To estimate the distribution of the jet gas, the applied air was tagged with

The solids concentration distribution shows a half jet angle of $\theta = 13.7^\circ$ and a jet penetration depth of $L_{Jet} = 110$ mm. The jet length agrees well with the value calculated by using Merry's correlation but the jet angle is significantly smaller than calculated by means of Merry's correlation. The reasons for that might be the definition of the jet angle by Merry (2), using the diameter of separating bubbles from the jet and the investigation of gas jets in a two-dimensional fluidized bed.

helium and its concentration was measured with the use of a mass spectrometer. Radial profiles were recorded and the local concentration of helium C was related to the cross-sectional average value C_0 . The dimensionless radial concentration profiles are mirrored at the vertical reactor axis at $r/R = 0$. Profiles are diagrammed for different axial distances h from the nozzle mouth in Fig. 6. For smaller distances clearly higher values of C/C_0 in the centre of the fluidized bed ($r/R = 0$) are obtained (e.g. $C/C_0 > 50$ for $h = 5$ mm).

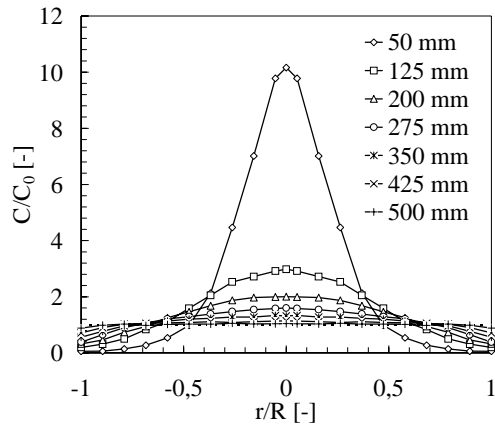

Fig. 6: Radial dimensionless tracer gas concentration profiles C/C_0 ; $U_G = 0.46$ m/s, $U_{Jet} = 60.13$ m/s, $d_p = 732$ μ m, $\rho_S = 2480$ kg/m³, $h_{bed} = 700$ mm

can be divided into two parts: from $h = 0$ mm to $h = 50$ mm and from $h = 50$ mm to the highest regarded distance of $h = 500$ mm. The following values are obtained to calculate the jet radius r_{Jet} using $r_{Jet} = r_0 + h \cdot \tan \theta$:

$$r_0 = 43.0 \text{ mm and } \theta = 4.9^\circ \text{ (} 50 \text{ mm} < h < 500 \text{ mm)}$$

$$r_0 = 10.3 \text{ mm and } \theta = 38.7^\circ \text{ (} 0 \text{ mm} < h < 50 \text{ mm)}$$

$$r_0 = 8.3 \text{ mm and } \theta = 11.4^\circ \text{ (} 0 \text{ mm} < h < 500 \text{ mm)}$$

For $h = 0$ mm the nozzle radius is set to be the jet radius.

Beside the jet angle θ , the jet length L_{Jet} is of interest regarding a potential reaction region. Fig. 8 shows the axial characteristics of the dimensionless helium concentration C/C_0 at the radial position $r/R = 0$ directly above the nozzle mouth.

Up to a vertical distance of $h \approx 120$ mm, a clear decrease of the concentration can be detected. For larger distances, the decrease in concentration takes place much weaker. Thus a jet penetration depth of about $L_{Jet} = 120$ mm – comparable with the jet length estimated by the solids concentration – can be determined.

With increasing the axial distance h , the dimensionless concentration decreases in the centre of the reactor and next to the wall an increase can be detected. A dimensionless concentration of $C/C_0 = 1$ is assumed to be the limiting concentration of the jet region. In Fig. 7 the radial positions at which the concentration profiles cross $C/C_0 = 1$ are plotted against the dimensionless radius r/R . The graph shows no linear dependency over the total investigated distance from the nozzle mouth, but it can be

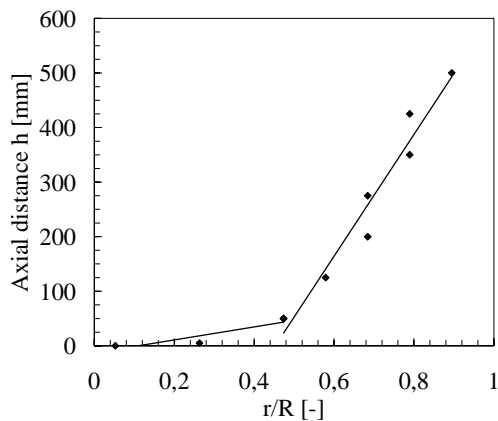

Fig. 7: Boundary of jet region on the basis of jet gas distribution; $U_G = 0.46$ m/s, $U_{Jet} = 60.13$ m/s, $d_p = 732$ μ m, $\rho_S = 2480$ kg/m³, $h_{bed} = 700$ mm

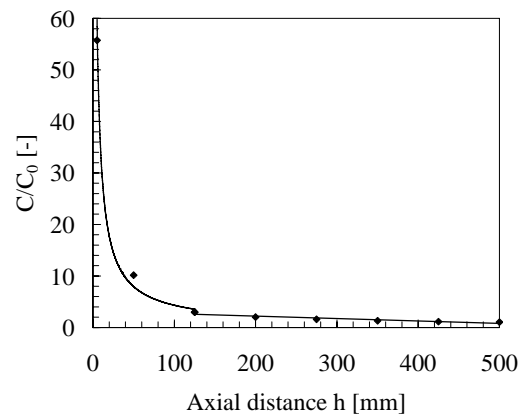

Fig. 8: Dimensionless jet gas concentration C/C_0 at the radial position $r/R = 0$ depending on the axial distance h ; $U_G = 0.46$ m/s, $U_{Jet} = 60.13$ m/s, $d_p = 732$ μ m, $\rho_S = 2480$ kg/m³, $h_{bed} = 700$ mm

The determination of the jet length using gas mixing experiments with the chemically inert gas helium inert results in the largest extension of the jet length. With a chemical reaction the relevant jet length is much shorter. For changing parameters like temperature or different fluidizing medium standard scale-up criteria can be used.

4. CONCLUSIONS

By using different parameters like solids concentration and jet gas distribution different jet region boundaries can be estimated which is shown in Fig. 9.

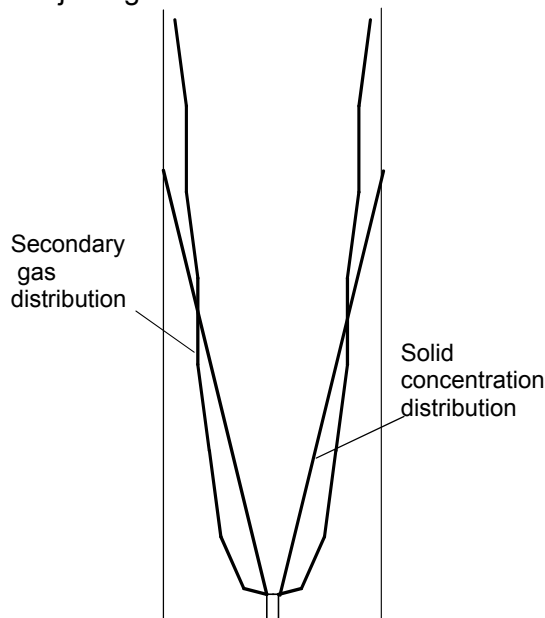

Fig. 9: Boundaries of jet region on the basis of different parameters; $U_G = 0.47$ m/s; $U_{Jet} = 60.13$ m/s; $d_p = 732$ μ m; $\rho_S = 2480$ kg/m³; $h_{bed} = 700$ mm

If a CVD-reaction should be implemented in a fluidized bed reactor, some terms must be fulfilled: a solids concentration as high as possible near the nozzle to provide the injected reactant gas enough surface area for deposition, avoiding e.g. homogenous gas phase reactions. The jet gas should be well distributed over a wide range of the cross sectional area to use the possible reactor volume for the reaction and guarantee a homogenous coating of the particles. But a problem can be the deposition of solid material on the reactor wall. Thus the contact between the reactant gas and the normally hot reactor wall should be in large distances h from the

nozzle. Fig. 9 shows regions next to the nozzle mouth with high solids concentration and high jet gas concentration, thus adequate conditions for chemical reactions at the particle surface exist.

The definition of a jet region depends on the related parameter like solids and jet gas distribution which are relevant for the reaction considered and may influence them in a different way.

5. LIST OF SYMBOLS

C	Jet gas concentration
C_0	Mean cross sectional jet gas concentration
c_s	Solids concentration
d_p	Mean particle diameter
d_0	Nozzle diameter
h	Axial distance from the nozzle mouth
h_{bed}	Bed height
L_{jet}	Jet length
L_I	Injector lance length
r	Radius
R	Radius of fluidized bed
U_0	Nozzle gas velocity
U_G	Superficial gas velocity
U_{jet}	Jet gas velocity
U_s	Solids velocity
$(1-\epsilon)$	Solids concentration
$(1-\epsilon)_{Mean, jet}$	Mean solids concentration within the jet
ρ_s	Solids density

6. REFERENCES

- (1) Markhevka, V.I., Basov, V. A., Melik-Akhnazarov, T. Kh. und Orochko, D. I.: *The Flow of a Gas Jet into a Fluidized Bed*, Theor. Foundations Chem. Eng., 5, 1971, pp. 80-85
- (2) Merry, J.M.D.: *Penetration of Vertical Jets into Fluidized Beds*, AIChE Journal, Vol. 21, 3, 1975, pp. 507-510
- (3) Merry, J.M.D.: *Fluid and particle entrainment into vertical jets in fluidized beds*, AIChE Journal, 22, 1976, pp. 315-323
- (4) Massimilla, L.: *Gas Jets in Fluidized Beds*, in: FLUIDIZATION 2nd Edition, Davidson, J. F., Clift, R. und Harrison, D. (Eds.), Academic Press, London, 1985, pp. 133-172
- (5) Wu, C., Whiting, W. B. : *Interacting jets in a fluidized bed*, Chem. Eng. Comm., 73, 1988, pp. 1-17
- (6) Cleaver, J.A.S. Ghadiri , M. Tuponogov, V.G. Yates, J.G. Cheesman, D.J.: *Measurement of jet angles in fluidized beds*, Powder Technology, 85, 1995, pp. 221-226
- (7) T. Kimura, T., Horiuchi, K., Watanabe, T., Matsukata, M., Kojima, T.: *Experimental study of gas and particle behaviour in the grid zone*

of a jetting fluidized bed cold model, Powder Technology, 82, 1995, pp. 135–143

- (8) Lim, K.S., Zhu, J.X., Grace, J.R.: *Hydrodynamics of gas-solid fluidization*, Int. J. Multiphase Flow, 21, 1995, pp. 141-193
- (9) Ruoyu Hong Hongzhong Li, Haibin Li, Yang Wang: *Studies on the inclined jet penetration length in a gas-solid fluidized bed*, Powder Technology, 92, 1997, pp. 205-212
- (10) Vaccaro, S., Musmarra, D. Petrecca, M.: *A technique for measurement of the jet penetration height in fluidized beds by pressure signal analysis*, Powder Technology, 92, 1997, pp. 224–231
- (11) Vaccaro, S., Musmarra, D. und Petrecca, M.: *Evaluation of the jet penetration depth in gas-fluidized beds by pressure signal analysis*, Int. J. Multiphase Flow, 23, 4, 1997, pp. 683-698
- (12) Musmarra, D.: *Influence of Particle Size and Density on the Jet Penetration Length in Gas Fluidized Beds*, Ind. Eng. Chem. Res., 39, 2000, pp. 2612-2617
- (13) Copan, J. Clarke, N., Berruti, F.: *The interaction of single- and two-phase jets in fluidized beds*, in: FLUIDIZATION X, Kwauk, M., Li, J. (Eds.), Beijing, China, 2001, pp. 77–84
- (14) Guo, Q., Zhang, J., Yue, G., Liu, Z.: *Particle concentration distribution and penetration depth in a jetting fluidized bed*, in: FLUIDIZATION X, Kwauk, M., Li, J. (Eds.), Beijing, China, 2001, pp. 141-148
- (15) Richtberg, M.: *Charakterisierung der lokalen Strömungsverhältnisse in einer druckaufgeladenen Zirkulierenden Wirbelschicht*, Dissertation an der Technischen Fakultät der Universität Erlangen-Nürnberg, Erlangen, 2001
- (16) Werther, J.: *Fluidized-Bed Reactors*, in: Ullmann's Encyclopedia of Industrial Chemistry, Wiley-VCH, Weinheim, 2002
- (17) Choy, K.L.: *Chemical vapour deposition of coatings*, Progress in Materials Science, 48, 2003, pp. 57-170
- (18) Yang, W.: *Bubbling Fluidized Beds*, in: Handbook of Fluidization and Fluid-Particle Systems, Yang, W. (Ed.), Marcel Dekker Inc., New York, Basel, 2003, pp. 53-111
- (19) Yang, W.: *Other Nonconventional Fluidized Beds*, in: Handbook of Fluidization and Fluid-Particle Systems, Yang, W. (Ed.), Marcel Dekker Inc., New York, Basel, 2003, pp. 545-570

7. KEYWORDS

fluidized bed, gas jet, jet region, nozzle, secondary gas injection, bubbling bed