

Refereed Proceedings

The 12th International Conference on

Fluidization - New Horizons in Fluidization

Engineering

Engineering Conferences International

Year 2007

Performance Characteristics of an 8
MW(th) Combined Heat and Power
Plant Based on Dual Fluidized Bed
Steam Gasification of Solid Biomass

Tobias Pröll*

Reinhard Rauch†

Christian Aichernig‡

Hermann Hofbauer**

*Vienna University of Technology, tobias.proell@tuwien.ac.at

†Vienna University of Technology

‡Repotec Umwelttechnik GmbH

**Vienna University of Technology

This paper is posted at ECI Digital Archives.

http://dc.engconfintl.org/fluidization_xii/115

PERFORMANCE CHARACTERISTICS OF AN 8 MW_{TH} COMBINED HEAT AND POWER PLANT BASED ON DUAL FLUIDIZED BED STEAM GASIFICATION OF SOLID BIOMASS

Tobias Pröll^a, Reinhard Rauch^a, Christian Aichernig^b, and Hermann Hofbauer^a

^a) Vienna University of Technology

Institute of Chemical Engineering

Getreidemarkt 9/166, 1060 Wien, Austria

T: +43 1 58801 15965; F: +43 1 58801 15999; E: tobias.proell@tuwien.ac.at

^b) Repotec Umwelttechnik GmbH

Europastrasse 1, 7540 Guessing, Austria

ABSTRACT

The work focuses on a dual fluidized bed gasification technology for which a model has been developed and validated accompanying the operation of the 8 MW_{th} biomass combined heat and power plant in Guessing/Austria. The reactor concept is a circulating fluidized bed system with a large steam-fluidized bubbling bed integrated into the solids return loop. The solids circulation rate is shown versus the riser exit velocity. Further, plant performance maps are presented for both electric and heat power output. The water content of the fuel is a major parameter with respect to plant performance. High fuel water content at high gas engine load means high gas velocities in the riser (erosion limit) and higher heat share in the produced energy.

INTRODUCTION

The utilization of biomass as primary energy source contributes to the preservation of natural resources and reduces the need for long-distance transport of energy. Fluidized bed steam gasification of solid biomass produces a high quality synthesis gas, which can be used for efficient combined heat and power production (CHP) using gas engines, gas turbines, or fuel cells and as an intermediate product for chemical syntheses (Fischer-Tropsch, methanol, synthetic natural gas, etc.). Thermal decomposition of organic matter requires high temperatures. The gaseous products must be cooled prior to gas cleaning. Therefore, the process inherently provides heat as a by-product.

If steam is the gasification agent, heat must be provided to the process either by in-bed heat exchangers [1] or by externally heated circulating hot bed material [2, 3]. A dual fluidized bed (DFB) technology has been developed in Austria using steam as the gasification agent and providing the heat for the gasification reactor by circulating bed material [4]. As shown in Fig. 1, the biomass enters a bubbling fluidized bed gasifier where the steps of drying, devolatilization, and partially heterogeneous char gasification take place at temperatures of 850-900 °C. Residual biomass char leaves the gasifier together with the bed material through an inclined, steam fluidized chute

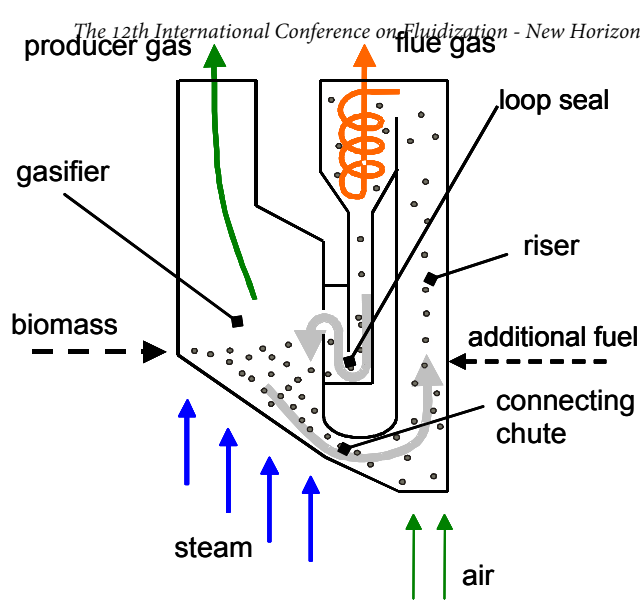

Fig. 1: Dual bed steam gasification of solid biomass.

between combustion and gasification reactor is determined by the necessary energy for gasification and the bed material circulation rate. Further parameters with energetic significance are the amount of residual char that leaves the gasifier with the bed material and the gasification temperature. The system is inherently auto-stabilizing in the sense that a decrease of the gasification temperature leads to a higher amount of residual char, which enhances combustion. This, in turn, transports more energy into the gasification zone and stabilizes the temperature. In practise, the gasification temperature can be influenced by addition of fuel (recycled producer gas, saw dust, etc.) to the combustion section. The pressure in both gasifier and riser is close to atmospheric conditions. The technology produces two separate gas streams, a high quality producer gas and a conventional flue gas at high temperatures. The producer gas is generally characterized by a low content of condensable higher hydrocarbons (tar), low N_2 , and a high H_2 content of 35-40 v-% (dry basis). The tar content decreases if catalytically active bed material is used [5].

THE BIOMASS COMBINED HEAT AND POWER PLANT AT GUESSING

At the biomass combined heat and power (CHP) plant at Guessing/Austria, the technology has been successfully demonstrated at a scale of 8 MW_{th} (fuel power based on lower heating value) together with appropriate gas conditioning and electricity generation in a gas engine [6]. Besides district heat for house-warming, the plant provides heat for industrial drying facilities and is in continuous operation throughout the year. More than 18 000 hours of engine operation have been reached since the generator has been connected to the grid for the first time in April 2002.

The configuration of the CHP plant is shown in Fig. 2. Wood chips from forestry are used as biomass fuel. The wood trunks are dried naturally by storage of 1-2 years in the forest before they are delivered and chipped on-site. The actual biomass water content is 25-35 wt-%.

towards the combustion reactor. The combustion zone serves to heat up the bed material and is designed as highly expanded fluidized bed (riser). Air is used as fluidization agent in the riser. After particle separation from the flue gas in a cyclone, the hot bed material flows back to the gasifier via a loop seal. Both the loop seal and the connecting chute are fluidized with steam. This results in effective prevention of gas leakages between gasification and combustion zone. At the same time a high flow rate of solids is possible. The temperature difference

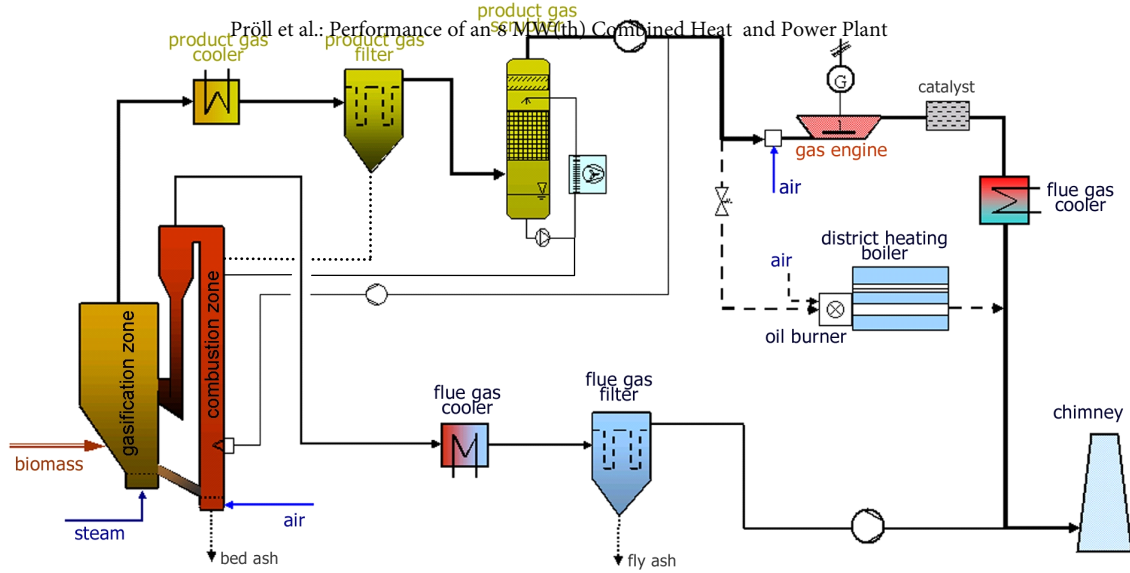

Fig. 2: The 8 MW_{th} biomass CHP plant in Guessing/Austria.

The raw producer gas is cooled to 150 °C before the bag filter. The fine char separated in the filter amounts to about 7 % (lower heating value) of the raw producer gas power and is recycled into the combustion zone of the gasification system. The tar scrubber uses rape oil methyl ester (RME) as solvent and reaches high tar separation efficiencies of about 99 % for tars detectable with gravimetric methods. Under operating conditions, condensation of water occurs in the tar scrubber. This leads to an increase of the clean gas heating value and allows the removal of water-soluble trace components like NH₃ and HCl. The condensate is separated from the organic scrubbing liquid and is partially used for generation of fluidizing steam while the rest is fed into the combustion reactor as saturated steam. The water content in clean producer gas is limited by water vapour saturation at scrubber exit. Seasonal variation of the scrubber exit temperature (45-70 °C) results in clean gas water contents between 10 and 30 v-%.

A part of the tar-loaded RME/condensate emulsion from the scrubber is continuously fed to the combustion zone representing the sink for the separated tar. A low amount of clean producer gas is recycled into the combustion reactor in order to control the gasification temperature. A GE Jenbacher J620 gas engine is used for power generation. An oxidation catalyst minimizes the emissions from the engine. The catalyst has been tested for 16 000 hours and shows still satisfying activity. The only streams exiting the plant are the clean stack gas and the ash from the flue gas filter. Heat for the local district heating grid is transferred from producer gas cooling, flue gas cooling, and engine exhaust cooling. Alternatively to the gas engine, a conventional gas boiler for heat generation is available. The district heating grid is operated at

Table 1: Design data of the CHP plant in Guessing/Austria.

Thermal fuel power (basis LHV)	8000	kW
Net power of producer gas (basis LHV)	5600	kW
Generator output	2000	kW
Electric consumption of the plant	200	kW
Net electric output	1800	kW
Net heat production	4500	kW

Published by ECI Digital Archives, 2007

relatively high temperatures of about 120 °C, which is not a problem for the gasification based CHP concept due to the high-level heat available out of the hot gas streams. The design data of the plant are summarized in Table 1.

PROCESS MODEL STRUCTURE FOR PERFORMANCE CALCULATIONS

A model has been developed and validated accompanying the operation of the prototype CHP plant. The process model covers the entire CHP plant between fuel supply and final energy output to the electric grid and district heating grid. This includes the unit models of the main components shown in Fig. 2 as well as all additional piping, pumps, and heat exchangers of the heat collection system (pressurized hot water cycle). A description of the detailed simulation flowsheet or of certain unit models exceeds the possibilities within this article. Generally, all the units strictly fulfill mass and energy conservation and feature specific additional equations that may either be derived analytically (thermodynamics, chemical kinetics, etc.) or may be determined empirically from measured plant data during parameter variations at the large scale plant. Some of the analytical approaches with respect to the gasification step itself have been described earlier together with the description of the validation procedure [7]. Here, an example for an empirical correlation is reported: the solids circulation rate of the system as a function of the gas velocity at riser exit. Because of the significant energy consumption in the gasifier leading to a temperature difference between gasification and combustion reactor, the solids circulation rate is a key parameter for the dual fluidized bed system and can be calculated from the mass and energy balances. Figure 3 shows the specific solids transport rate in the combustion reactor (riser) versus the superficial gas velocity at riser exit. The total riser height is 10 m and natural olivine is used as bed material (mean particle diameter: 540 μm , apparent density 2960 kg/m^3). The slope of the regression line is mainly determined by the single datum at an exit velocity of about 8 m/s. The rest of the data points scatter between 45 and 70 $\text{kg}/(\text{s}\cdot\text{m}^2)$ in a narrow velocity range between 10 and 12 m/s. According to cold flow model results on the DFB behaviour, cross sensitivity on the solids circulation rate can be expected from the total solids inventory and from the air staging in the riser. However, the data on these quantities are not accurately determined at the plant and, therefore, the model is kept simple taking only the exit velocity into account. It can be observed that the riser velocity is relatively high compared to common CFB applications, where values of 5-7 m/s are typically designed. On the one hand, high solids circulation rates are advantageous with respect to energy efficiency because of lower temperature differences between the

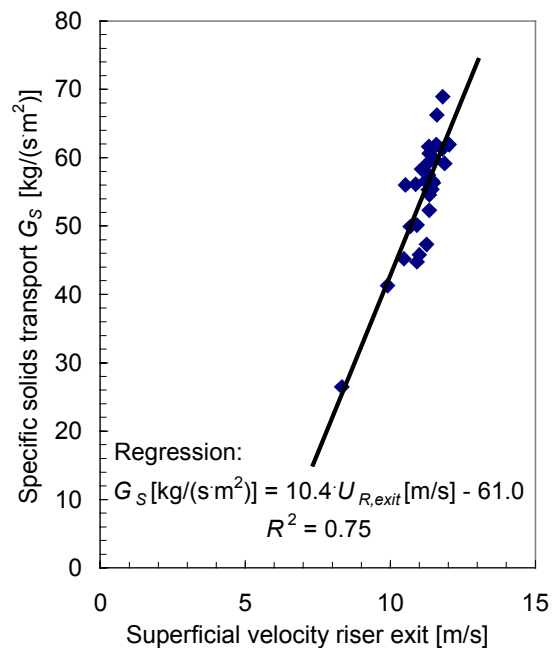

Fig. 3: Solids transport rate vs. riser exit velocity.

http://dx.doi.org/10.1002/eng.21115

reactors and consequently lower flue gas exhaust temperatures. On the other hand, increased erosion in the riser exit zone and cyclone requires shorter maintenance intervals for the refractory lining. Practically, the high velocities are the result of fuel water contents much higher than the plant has been initially designed for. The refractory was reworked for the first time after about 12 500 hours of operation. It can be recommended for future plants to choose a design that combines high solids transport with moderate riser velocities, e.g. by increasing the solids hold up in the riser via the total solids inventory.

The process model is used in the following section to calculate the plant behaviour during variations of operating parameters. Practically, during the variation, the prescribed parameters gas engine load and fuel water content determine the main extensive quantities of the process (mass and energy flows). The fuel power input to the gasifier is determined by the amount of producer gas needed. The producer gas need is determined by gas engine load and the producer gas recycled to the riser for means of temperature control. The amount of producer gas to be recycled strongly depends on the fuel water content. The rest of the process variables are either determined from model equations or set to constant values. Some of the important constant parameters are summarized in the results section (Table 2).

RESULTS AND DISCUSSION

A type of performance map well known for combustion-based power plants can as well be used for the gasification based CHP plant showing both electrical and heat output for the practical range of operation [8]. The quantities used to describe the operating range are the total wet fuel mass flow, the effective electrical power output at the generator, and the total heat generation for district heating purposes. The process parameters used to further describe the different operating states are fuel water content, riser exit velocity, and gas engine load. The baseline for the calculations is a

reference plant operation based on measured data [7]. The most important of the other operating parameters, which are not subject to variation within the present work, are summarised in Table 2. The efficiency of the gas generation step increases as the gasifier temperature decreases.

Therefore, the gasifier temperature is practically set to the lowest value possible with respect to tar formation. The combustion reactor temperature is coupled to the gasifier temperature by the circulating solids and is typically 40-70 K higher than the gasifier temperature depending mainly on the water content in the fuel.

The gas temperature after tar scrubber determines the water content in the engine fuel gas and must be kept as low as possible. The district heating boiler in bypass to

Table 2: Important constant process parameters.

Lower heating value (LHV) dry fuel (wf)	MJ/kg	17.55
Gasifier bed temperature	K	1123
Gasifier bed pressure drop (solids hold up)	kPa	10.5
Steam to fluidization	kg/h	500
Part of combustion air to bottom nozzles	%	20
Part of combustion air to primary air level	%	55
Part of combustion air to secondary air level	%	25
Excess air ratio combustion reactor	-	1.05
Gas temperature after tar scrubber	K	313
Part of producer gas to district heating boiler	%	5.0

the gas engine (Fig. 2) must be kept at stand-by, what requires 5 % of the clean producer gas.

The performance map for electric power output is shown in Fig. 4. It is assumed that the whole plant is operated in partial load if the gas engine is operated in partial load. The bounds of the operating range are maximum engine load on top, maximum riser exit velocity (erosion limit) to the right, and minimum engine load or minimum solids circulation rate respectively at the bottom. The bounds to the left (15 wt-% fuel water content) and to the lower right (40 wt-% fuel water content) are not of technological nature but represent the maximum range of available fuel at site. Figure 4 shows that the lines of constant riser velocities are almost vertical and, therefore, practically directly dependent on the wet fuel mass flow. At a given engine load, the fuel mass flow increases with increasing water content or decreasing heating value respectively. Since the gas engine is the only source of electrical power, the load factor of the engine is strictly linked to the electric plant output.

The performance map for district heat output is shown in Fig. 5. The tendencies observed are similar to Fig. 4 with the main difference that the heat output increases for constant gas engine load with increasing fuel water content. The reason is a higher cooling power from gasifier producer gas and combustion reactor exhaust gas because of higher gas mass flows for increased water loads in the system. The reason for the slight change in slope between 20 and 15 wt-% of fuel water content is that the amount of condensate available for steam generation is getting less than the required steam and, for fuel water contents lower than about 18 wt-%, additional water must be added for generation of fluidization steam.

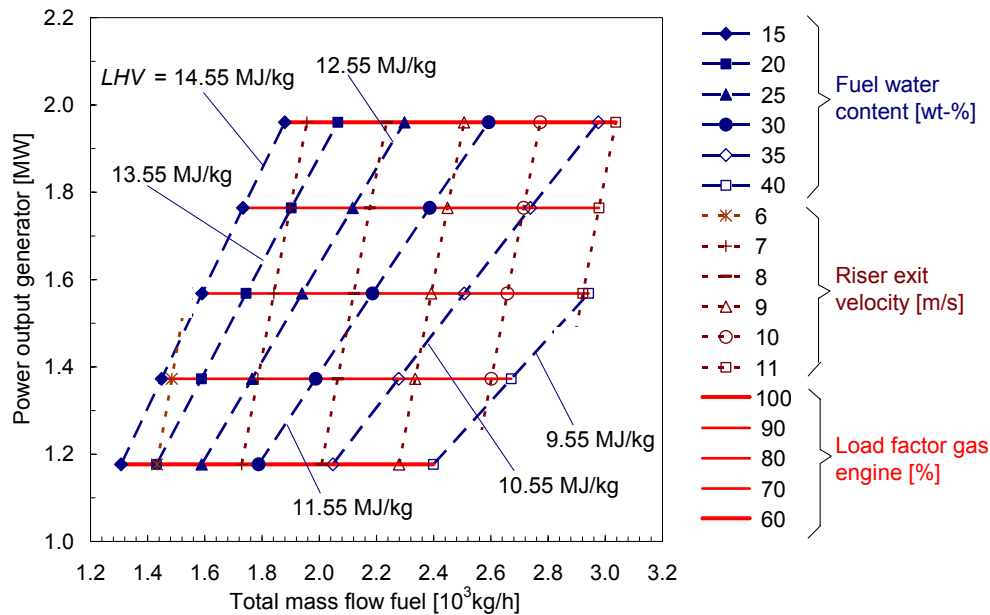

Fig. 4: CHP plant performance map 1: electric power output vs. total fuel mass flow.

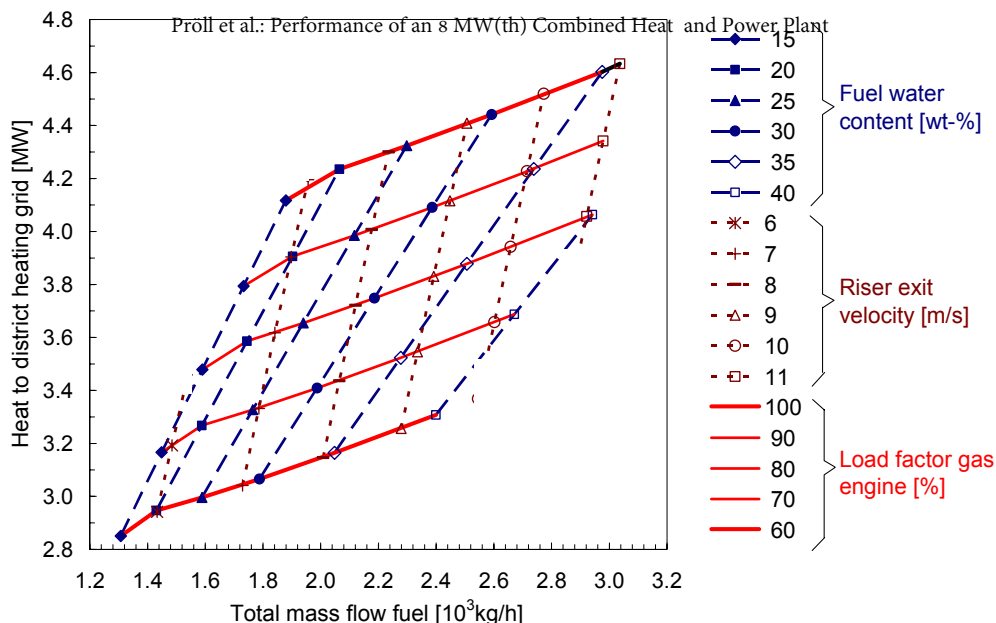

Fig. 5: CHP plant performance map 2: district heat output vs. total fuel mass flow.

Summarizing, the use of wet fuel in the DFB gasifier leads to significantly higher riser velocities and increases the share of heat in the total energy output. It is obvious that also the electric plant efficiency decreases with increasing fuel water content. The data shown in Figs. 4 and 5 represent the energy-based performance of the CHP plant in its current configuration. Further optimization will require changes of the plant equipment. Starting from improved control loops to minimize the amount of producer gas to the stand-by district heating boiler to zero, the integration of fuel drying and the utilization of high level heat in Rankine cycles for higher electric output are currently discussed on a techno-economic basis. The next generation plant, a 10 MW_{th} CHP installation, has now been ordered by the operator. Erection-start is scheduled for winter 2006/07 and electricity production for December 2007.

CONCLUSIONS

The dual fluidized bed steam gasification technology for solid biomass has been successfully demonstrated at a scale of 8 MW_{th} at the biomass combined heat and power plant in Guessing/Austria. In order to predict the plant behaviour at varied parameters, correlations between the process variables must be determined. The correlation between solids circulation rate and riser exit velocity shows that the quality of the empirical correlations is highly dependent on the available data. The plant performance maps show that the water content in the fuel strongly influences plant performance. High fuel water content at high gas engine load means high gas velocities in the riser (erosion limit) and higher heat share in the produced energy. The next generation DFB biomass gasification plant can be designed to be operated at moderate riser velocities of 7-8 m/s and possibly feature on-site fuel drying and a Rankine cycle (steam or organic working fluid) for increased electricity output.

ACKNOWLEDGEMENTS

The 12th International Conference on Fluidization - New Horizons in Fluidization Engineering, Art. 115 [2007]

This work has been carried out within RENET Austria – energy from biomass (www.renet.at). The authors gratefully acknowledge the financial support by the Austrian public funds program K_{NET}/K_{IND}.

REFERENCES

- [1] Karl, J.; Schmitz, W.; Hein, D., 2001, "Allothermal gasification in fluidized bed gasifiers", Fluidization X, Proceedings of the Engineering Foundation Conference on Fluidization, Beijing, China, May 20-25, 2001.
- [2] Hofbauer, H., Veronik, G., Fleck, T., Rauch, R., 1997, "The FICFB gasification process," In: Bridgwater, A.V., Boocock, D. (Eds.): Developments in thermochemical biomass conversion, Vol. 2, Blackie Academic & Professional, Glasgow, U.K., 1997, pp. 1016-1025.
- [3] Paisley, M. A., Farris, M. C., Black, J. W., Irving, J. M. and Overend, R. P., 2000, "Preliminary Operating Results from the Battelle/Ferco Gasification Demonstration Plant in Burlington, Vermont, U.S.A.," In: Kyrisits, S. et al. (Eds.): Proceedings of the First World Conference on Biomass for Energy and Industry, James&James., London, UK.
- [4] Hofbauer, H., Rauch, R., Löffler, G., Kaiser, S., Fercher, E., and Tremmel, H., 2002, "Six Years Experience with the FICFB-Gasification Process," In: W. Palz et al. (Eds.): Proc., 12th European Biomass Conference, ETA Florence, Italy, pp. 982-985.
- [5] Hofbauer, H., Rauch, R., 2000, "Stoichiometric water consumption of steam gasification by the FICFB-gasification process," Progress in Thermochemical Biomass Conversion, Innsbruck, Austria, September 2000 (<http://www.ficfb.at>).
- [6] Hofbauer, H., Rauch, R., Bosch, K., Koch, R., Aichernig, C., 2003, "Biomass CHP plant Guessing – a success story," In: Bridgwater, A.V. (Ed.): Pyrolysis and Gasification of Biomass and Waste, CPL Press, Newbury, UK, pp. 527-536.
- [7] Pröll, T., Rauch, R., Aichernig, C., Hofbauer, H., 2005, "Fluidized bed steam gasification of solid biomass: analysis and optimization of plant operation using process simulation", ASME Paper FBC2005-78129, Proc. of the 18th Int. Conf. on Fluidized Bed Combustion, May 23-25, 2005, Toronto.
- [8] Kaiser, S., Weigl, K., Schuster, G., Tremmel, H., Friedl, A., Hofbauer, H., 2000, "Simulation and optimization of a biomass gasification process," In: Kyrisits, S. et al. (Eds.): Proceedings of the First World Conference on Biomass for Energy and Industry, James&James., London, UK, pp. 1922-1925.