

Effect of Mixing and Scale on the Performance and Hydrodynamics of Anaerobic Digesters

Mehul Vesvikar and Muthanna Al-Dahhan

Bioreactors and Bioprocess Engineering Laboratory (BBEL),

Chemical Reaction Engineering Laboratory (CREL)

Washington University in St Louis, MO

DOE support # DE-FC36-01GO11054

Bioenergy-I, March 2006, Tomar, Portugal

CHEMICAL REACTION ENGINEERING LABORATORY



Introduction and Motivation

- Unsafe and improper disposal of about a billion ton of animal wastes generated every year in USA result in
 - Surface and ground water contamination
 - Ammonia leaching
 - Methane emission causing green house effect
 - Odors
- Treatment of these wastes by anaerobic digestion
 - Provides bio-energy (methane) and bio-fertilizer
 - Reduces pollution and odor

Anaerobic digestion

Anaerobic biodigestion is a biological process in which biodegradable organic materials are decomposed in the absence of oxygen to produce methane and carbon dioxide.

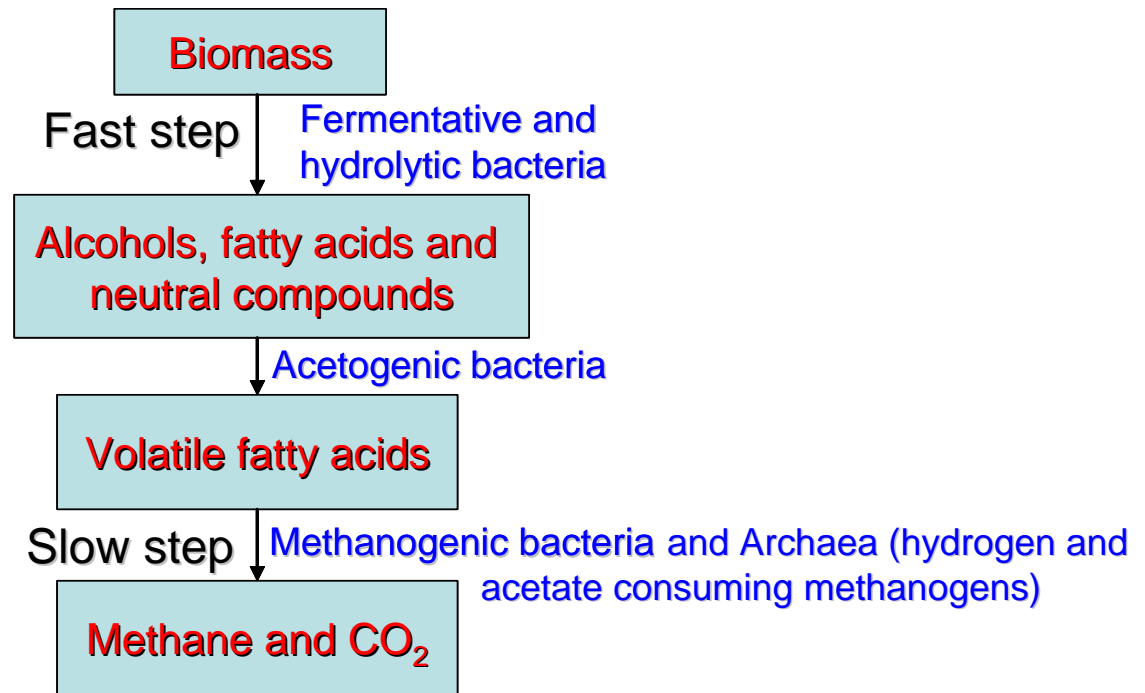

If the VFA's are not utilized at the rate they are produced, then it can kill the methanogenic activity due to lower pH

Mixing in digesters

- Role of mixing:
 - Enhances microorganisms and substrate contact and distribution
 - Ensures uniform pH and temperature
 - Prevents deposition of denser solids at the bottom and flotation of lighter solids at the top
 - Helps to release biogas bubbles
- Mixing can be provided by various methods
 - Mechanical agitation
 - Recirculation of biogas
 - Recirculation of digester slurry
 - Sometimes no mixing (plug flow reactor or lagoons)

Literature findings

- Role of mixing is appreciated by the researchers but systematic study to understand the impact of mixing on the performance of digesters is lacking in the literature.
- Few studies that investigated the impact of mixing provide contradictory findings. This could be due to the fact that the experimentations were carried in small scales (Ben-Hassan et al., 1985; Chen et al., 1990; Dague, 1970; Ho and Tan, 1985).

Objectives

The overall objective is to integrate the hydrodynamics and performance of anaerobic digesters to understand the impact of the hydrodynamics/mixing and scale on their performance.

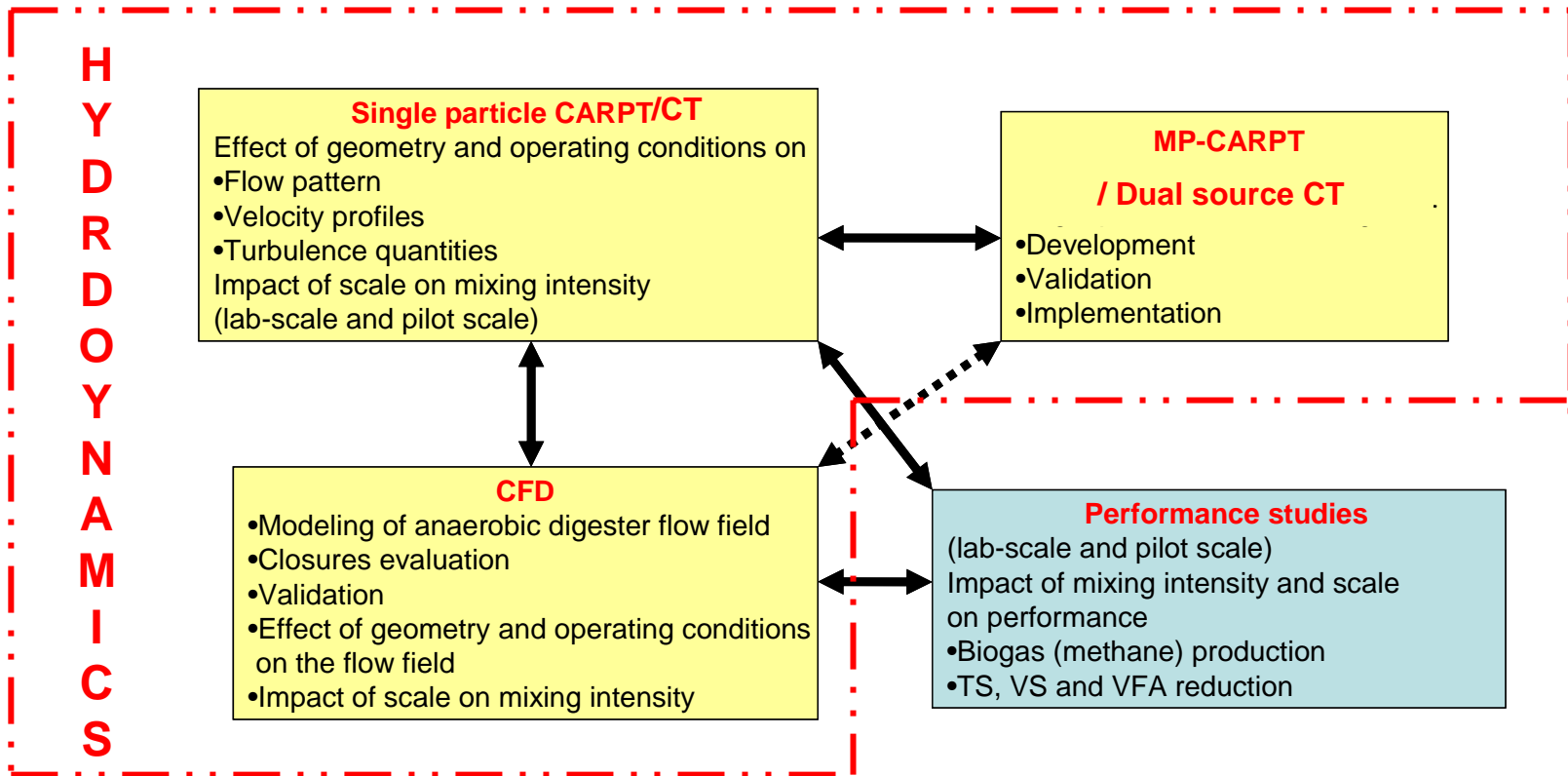

Mixing in Lab-Scale Digesters

Systematic lab-scale performance studies* were carried out to study the effect of the following variables on the performance of 6 inch diameter (3.78 L) digesters:

- Geometry of digester
- Mode of mixing (gas mixed, liquid recirculation, mechanical agitation and unmixed)
- Intensity of mixing (1-3 lpm gas flow rate)
- TS content in the feed (5% and 10%)

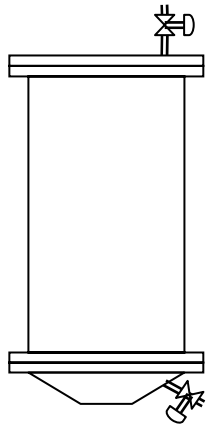

Unmixed

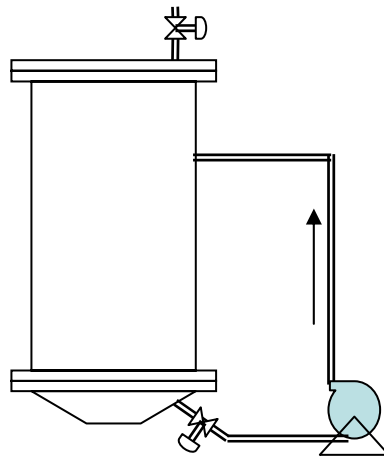

Slurry recirculation

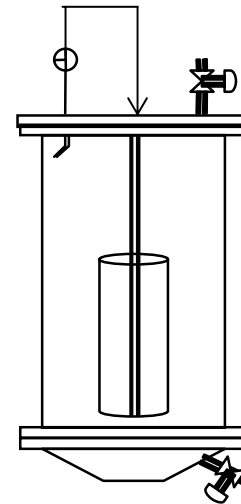

Biogas recirculation

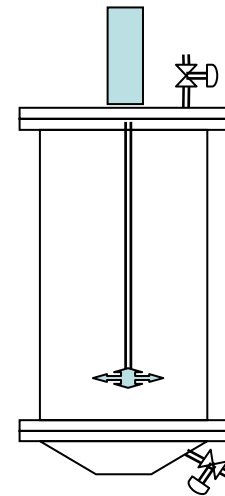

Impeller mixed

Energy input per unit volume was same, 8 W/m^3 , in all configurations

* Karim et al. 2005, Water Research, 39(15), 3597-3606

* Karim et al. 2005, Bioresource Technology, 96(16), 1771-1781

* Karim et al. 2005, Bioresource Technology, 96(14), 1607-1612

* Hoffmann R., 2005, Master's Thesis, Washington University, St. Louis, MO

Mixing in Lab-Scale Digesters

Findings:

- Variables mentioned before did not affect the performance of digester (measured in terms of biogas/methane production.)
- The mixing created by the evolution of gas bubbles and feeding mechanism provides sufficient mixing at this scale (6-inch digester).
- Thus, studies at larger scale of operation needs to be performed to understand the true effect of mixing on the performance of digester.

Type of Mixing	Biogas production rate (L/L/day)	Methane Yield (L/ gm VS loaded)	% TS reduction	% VS reduction
1. Unmixed	0.92	0.19	41	35
2. Gas Mixed	1.07	0.21	49	39
3. Impeller Mixed	1.14	0.23	47	41
4. Slurry Recirculation	1.20	0.24	45	35

Effect of Scale



6 inch diameter
3.78 L volume



18 inch diameter
97 L volume

Performed at BBEL (CREL, WUSTL) and ORNL (Oak Ridge, TN)

Lab-Scale (6-inch) and Pilot-Scale (18-inch) Digester

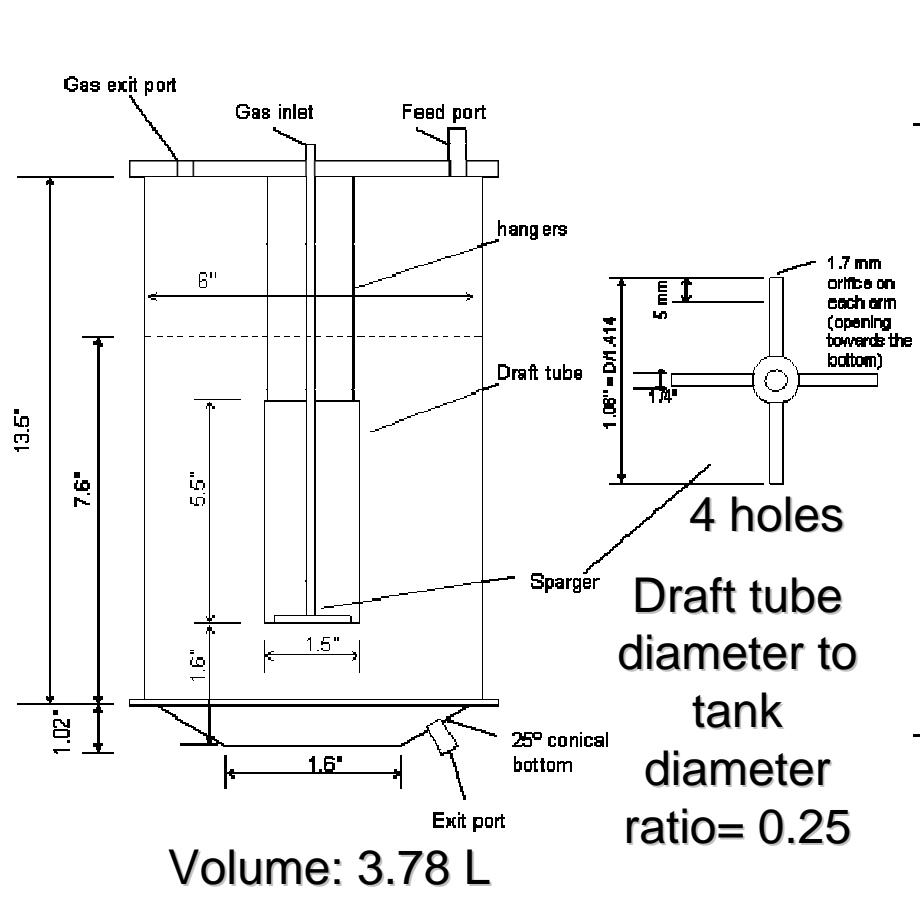

Lab-scale Digester Geometry

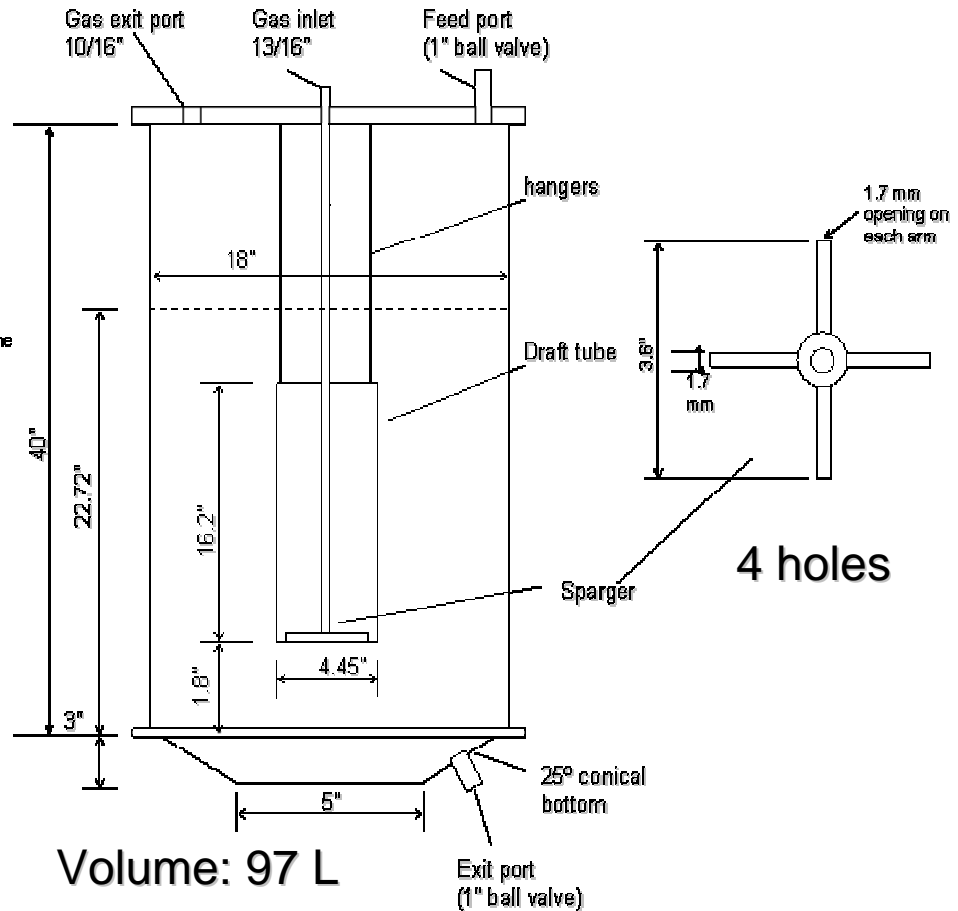

Pilot-scale Digester Geometry

Digester operation

- **Volume**
 - Lab-scale: 3.78 L (6 inches)
 - Pilot-scale: 97 L (18 inches), volumetric scale-up ratio = 25, geometric scale-up ratio = 3
- **Feed**
 - Treated cow manure with 6.6% VS, Volatile Solids (12% TS, Total Solids)
- **HRT: 16.2 days**
 - Lab-scale: (0.46 L of slurry fed and 0.46 L of effluent withdrawn every other day)
 - Pilot-scale: (12 L of slurry fed and 12 L of effluent withdrawn every other day)
- **Operation**
 - Mixed by gas recirculation
 - Unmixed (no external mixing is provided, some mixing presents due to the feeding and effluent withdrawal mechanism and due to the evolution of biogas bubbles)
- **Gas flow rate (equivalent to energy input density of 8 W/m³, suggested by EPA)**
 - Lab-scale: 1 lpm
 - Pilot-scale: 9 lpm
- **Analysis**
 - Total Solids, TS (drying sample in oven at 105 C)
 - Volatile Solids, VS (drying sample in furnace at 550 C)
 - Volatile Fatty Acids, VFA (GC)
 - Biogas production rate (Gas meter)
 - Biogas methane content (GC)

Biogas production

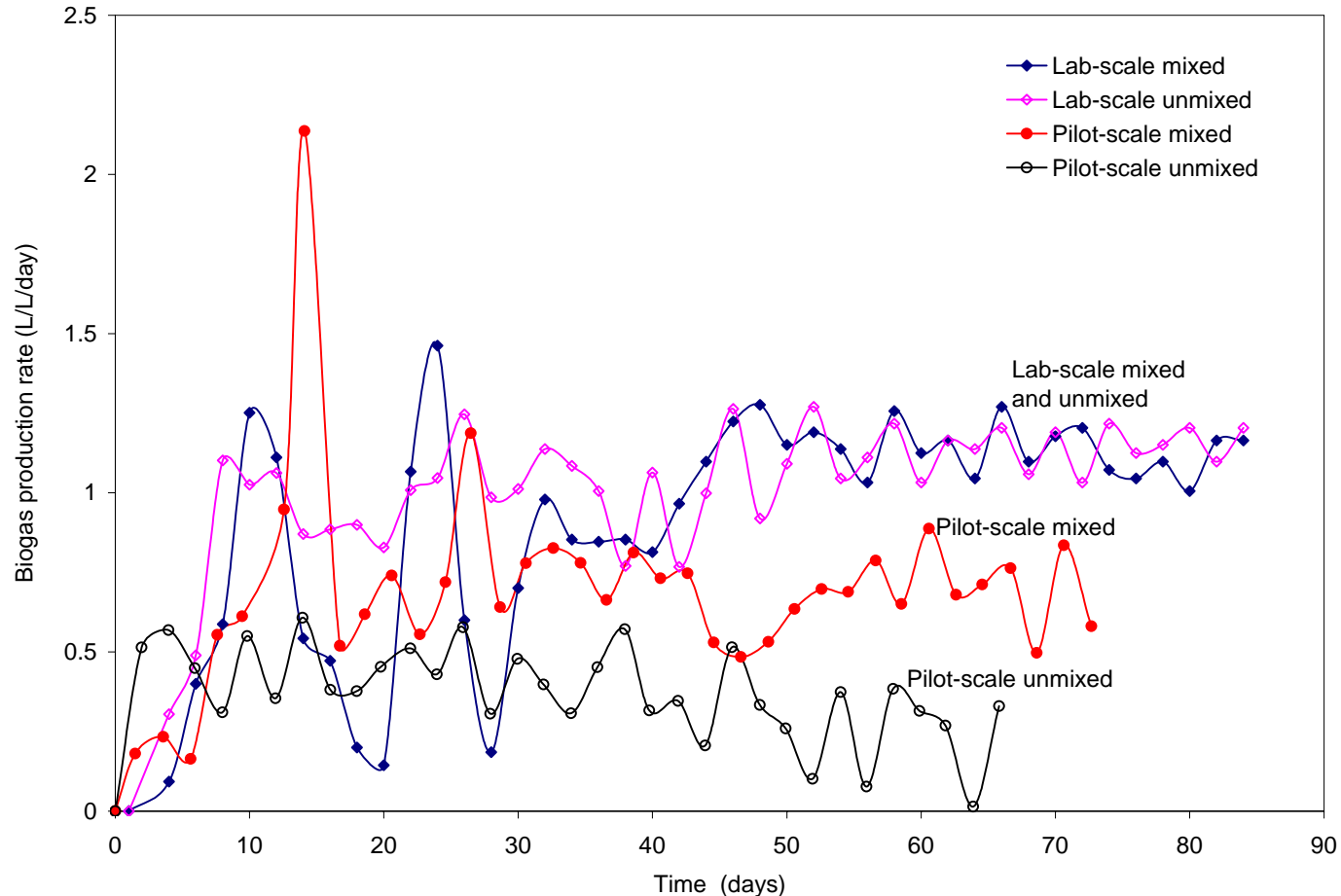

Comparison of lab-scale and pilot-scale

Methane Content

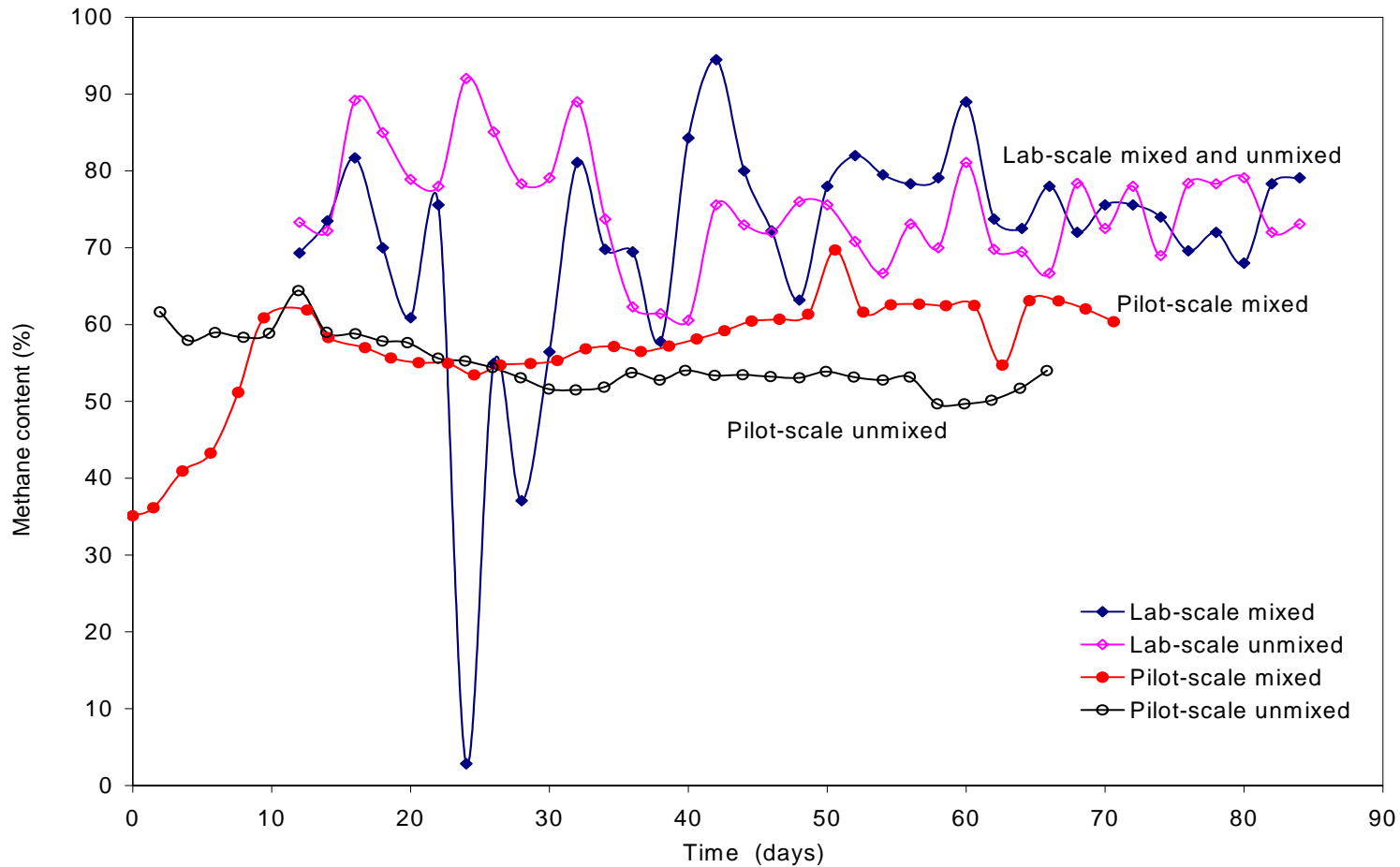

Comparison of lab-scale and pilot-scale

VFA content

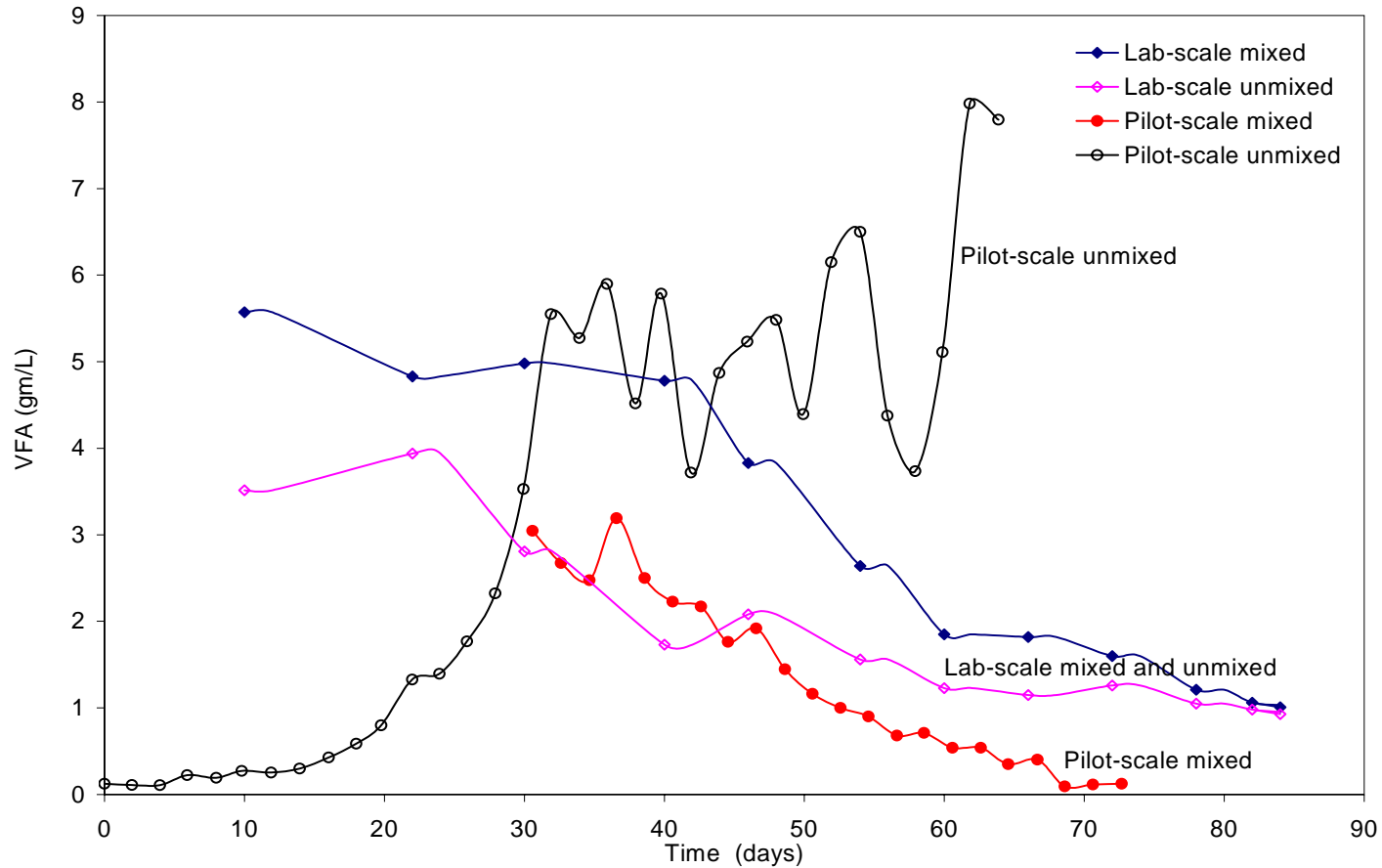

Comparison of lab-scale and pilot-scale

Cumulative methane production

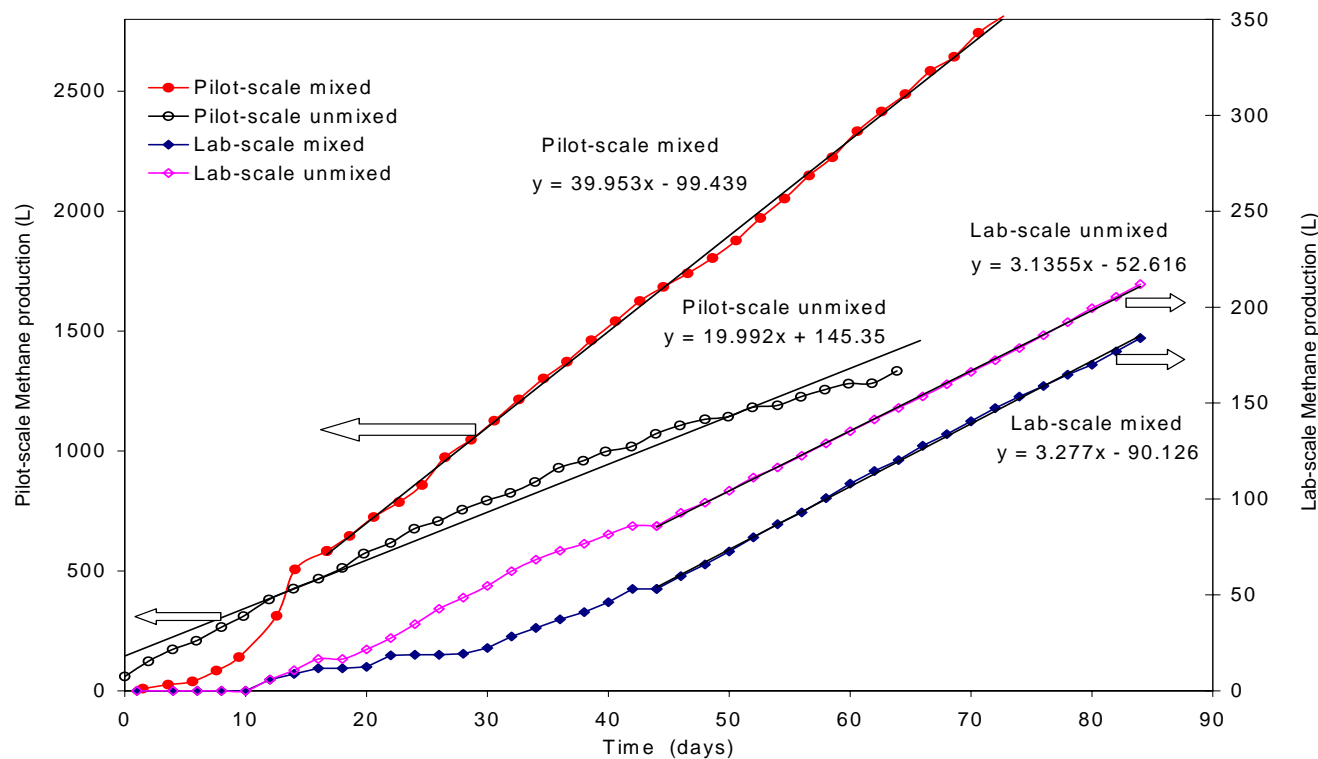

The slope of the line represents the methane production rate in L/day. For fair comparison, the biogas production is reported per unit volume of digester in the table below.

L/L/day	Lab-scale	Pilot-scale
Mixed	0.86	0.41
Unmixed	0.83	0.20

Why should mixing matter?

- A simplified anaerobic digestion reaction has three important biological steps. Hydrolysis followed by acetogenesis and finally methanogenesis. Acetogenesis is a faster reaction compared to the others producing acetic acids and other VFA's, whereas methanogenesis is a slower process creating biogas by utilizing acetic acid.
- If the digester is not mixed adequately, then the added feed will concentrate at a particular region in the digester. This feed will be converted to acetic acid by acetogens at a rate faster than the consumption of acids by methanogens, resulting in an increase in pH.
- Higher pH is detrimental to methanogens thus killing the methanogenic activity and resulting in digester failure.
- Thus mixing is required to create uniform environment in a digester to avoid its failure.

Effect of Mixing depends on Scale?

- Lab-scale digesters produce more biogas than pilot-scale digesters, operated under same conditions, because small-scale units are easy to control and small amount of mixing can guarantee uniform environment, thus enhancing the performance.
- Mixing created by the evolving biogas bubbles and feeding mechanism provides sufficient amount of mixing for the operation of small-scale digester. Any extra amount of mixing than required does not enhance the performance .
- In small-scale digesters, the mixing time scales could be smaller as compared to reaction time scales, thus mixing does not play a significant role in performance.
- As the size of operation increases, difficulty in achieving mixing increases thus mixing time scales increase whereas reaction time scales are unaffected. Thus mixing plays an important role in the performance of large-scale digesters.

Remarks

- For Bioenergy production as biogas, the following question arises: What would be the minimum energy input (in the form of mixing) that would maximize the bioenergy production?
- This question is yet to be answered..... Currently, the work is going on in our laboratory looking for such answer!!!
- Large scale experimentation is necessary to obtain reliable data that can be used for identifying the needed energy input and for scale-up and design of the anaerobic digesters.
- In this case, quantifying the mixing, flow pattern and hydrodynamics of anaerobic digester is essential and required. Due to the opacity of the digesters advanced and non-invasive techniques are needed.
- Advancements have been made in our current single-particle CARPT and single source CT and new techniques have been developed, which are;
 - Multiple particle tracking (MP-CARPT)
 - Dual source tomography (DSCT)
- In addition to understanding and quantifying the hydrodynamics and mixing of anaerobic digesters, these techniques provide the needed data to evaluate, validate and further develop CFD codes and closures. That could be implemented for scale-up and design.

To get velocity and Mixing Pattern

Computer Automated Radioactive Particle

Tracking (CARPT) single particle tracking

Distance vs count map
from calibration

+ Counts from detectors

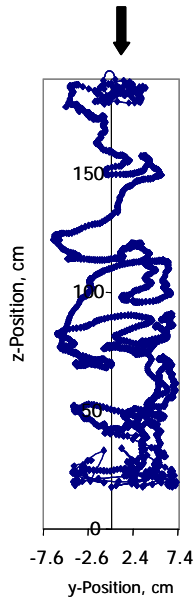

**Instantaneous
Positions (x,y,z,t)**



**Instantaneous
Velocities** → **Fluctuating
Velocities** → **Mean
Velocities** → **Reynolds Stresses, TKE
Eddy Diffusivities**

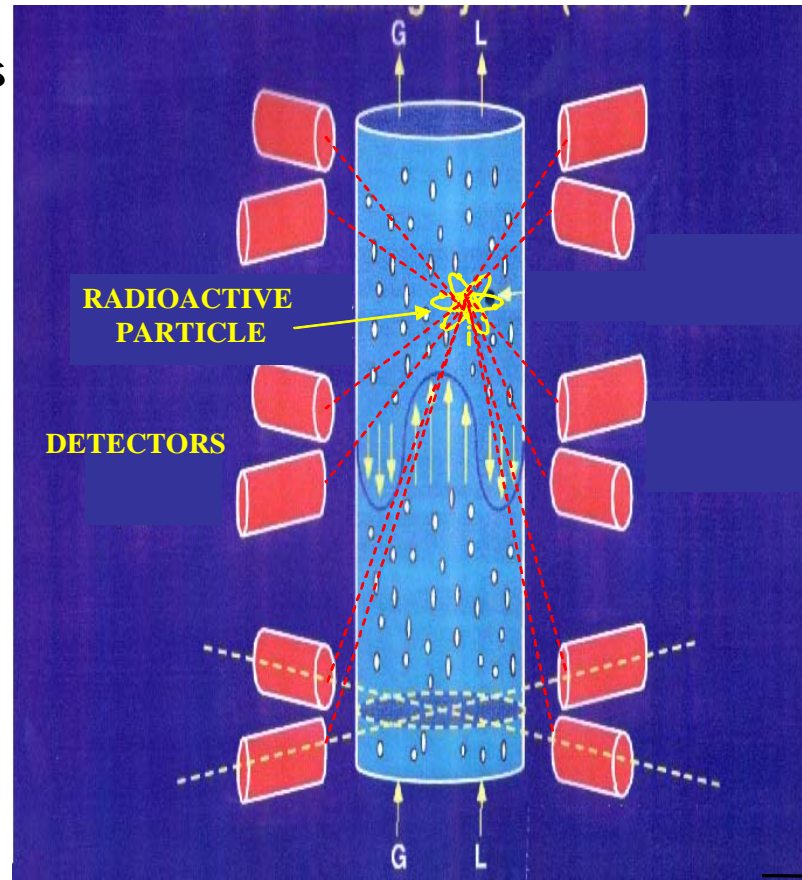

Radioactive
Particle:
136 mm SC - 46
with activity of 60
mCi enclosed in 1
mm polypropylene
ball.

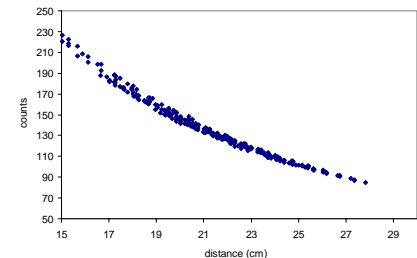

Calibration curve

Multiple Particle Tracking (MP-CARPT)

We have developed, tested and validated the MP-CARPT system for tracking many particles; the system has been tested and validated for tracking two particles (Sc-46 and Co-60).

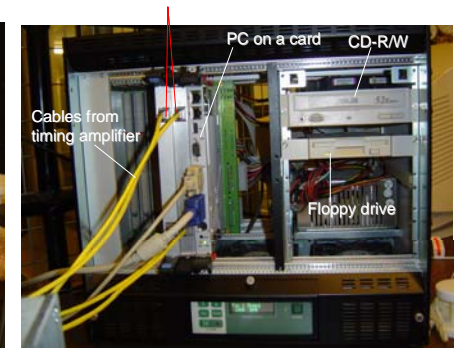
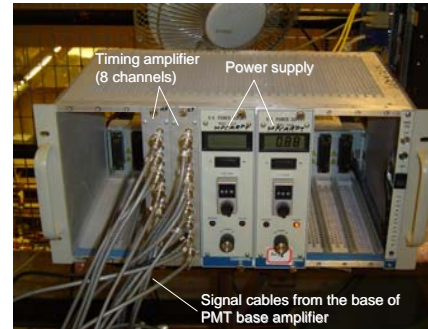
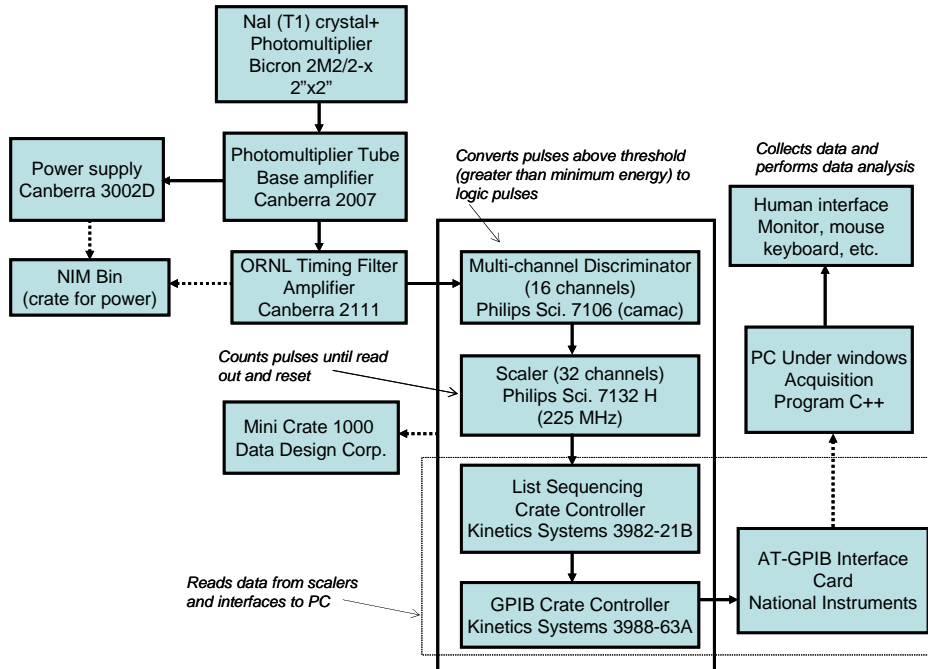

- MP-CARPT is the extension of single particle CARPT such that more than one radioactive particles can be tracked simultaneously.
- MP-CARPT provides the ability to track the motion of particles of different size, shape and density and different phases, thus determining segregation of particles and probing particles interaction. It also overcomes the limitations of single-particle CARPT and speeds up the data acquisition process.
- This technique might be useful for characterizing number of multiphase processes/reactor systems of industrial interests which use a range of particles and phases with different properties. e.g. gas-solid, liquid-solid, gas-liquid-solid fluidized beds.
- The newly developed MP-CARPT unit is compact, cheaper, faster and more efficient as compared to old single-particle CARPT unit

Dual-Source Computed Tomography (DSCT)

Two different equations obtained by scans with source of different energies

$$\epsilon_{g,ij} = \frac{R_{s,ij}^{(I)}}{R_{L,ij}^{(I)}} \epsilon_{s,ij} + (1 - \epsilon_{s,ij}) - \frac{R_{g-l-s,ij}^{(I)}}{R_{L,ij}^{(I)}}$$

$$\epsilon_{g,ij} = \frac{R_{g-l-s,ij}^{(II)}}{R_{L,ij}^{(II)}} \epsilon_{s,ij} + (1 - \epsilon_{s,ij}) - \frac{R_{g-l-s,ij}^{(II)}}{R_{L,ij}^{(II)}}$$



$$\epsilon_{s,ij} = \frac{\left[R_{G-L-S,ij}^{(I)} - R_{G-L-S,ij}^{(II)} \left(\frac{R_{L,ij}^{(I)}}{R_{L,ij}^{(II)}} \right) \right]}{\left(R_{S,ij}^{(I)} - R_{S,ij}^{(II)} \left(\frac{R_{L,ij}^{(I)}}{R_{L,ij}^{(II)}} \right) \right)}$$

A Combination Of Low Energy and High Energy sources is required

Combinations under evaluation

^{60}Co - ^{137}Cs ; ^{60}Co - ^{241}Am ,
 ^{60}Co - ^{75}Se

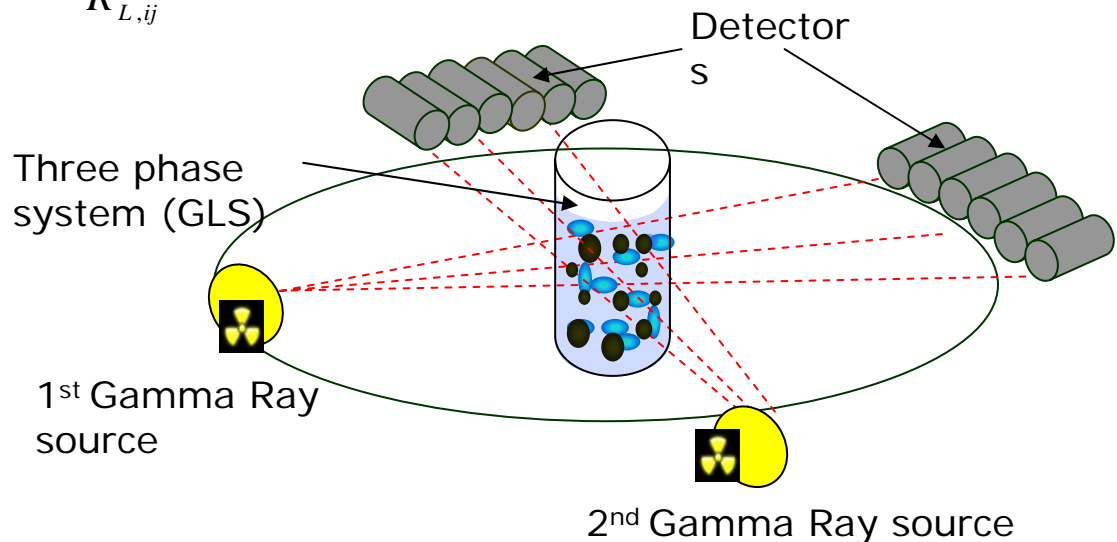

This technique is developed in CREL (Rajneesh Varma) and currently is in validation phase.

Effect of Scale on Hydrodynamics: CARPT Results

Flow pattern

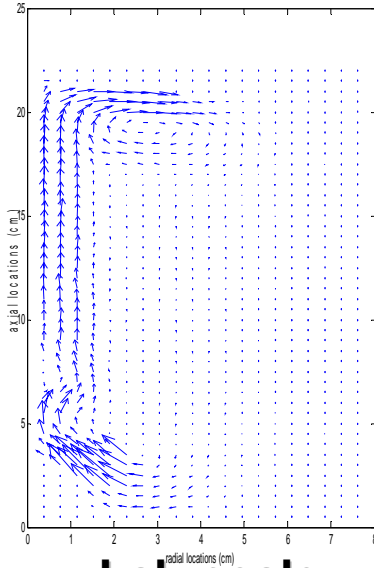

Lab-scale

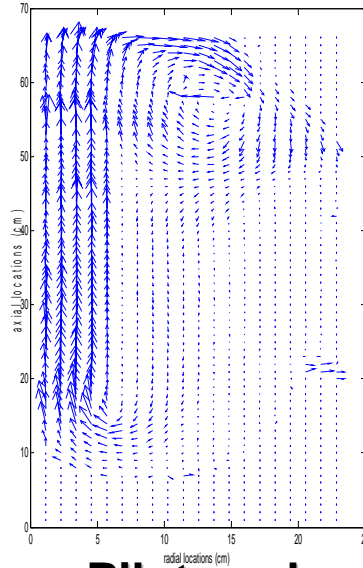

Pilot-scale

Liquid velocity profile

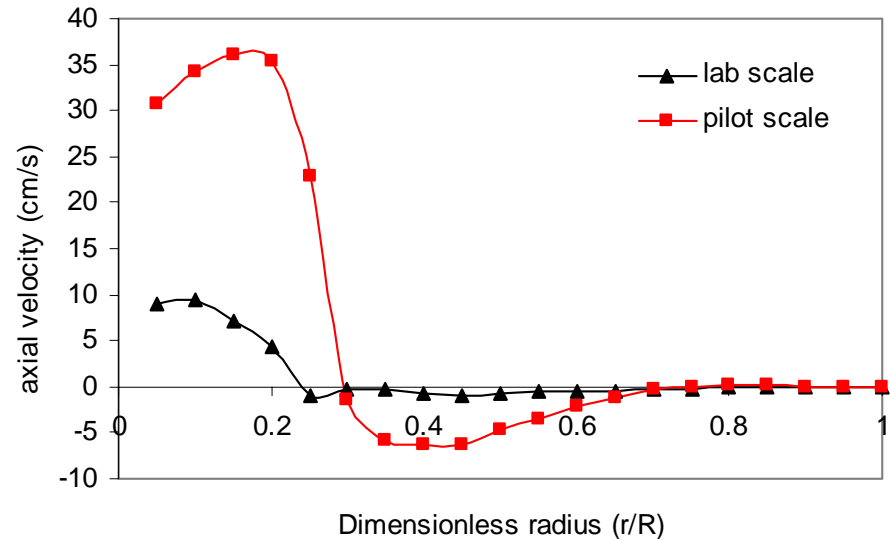

Hydrodynamic parameters	% dead volume	Circulation (mixing) time (seconds)
Lab-scale (1 lpm)	60	79
Pilot-scale (9 lpm)	65	126

Power input per unit volume in both scales was same, 8 W/m^3
(superficial gas velocity of 0.91 cm/sec based on tank diameter)

Summary

- CARPT data reveal that the mixing performance of lab-scale unit, in terms of dead volume and circulation time, is better than the pilot-scale at same energy input per unit volume. These results would explain why performance of lab-scale digesters was better than pilot-scale.
- Work in our laboratory is in progress to properly quantify the performance and the detailed hydrodynamics of anaerobic digester for operating energy efficiency, maximizing energy output, and for scale-up and design.

Acknowledgements

- Dr. Abhijeet Borole and Dr. David Depaoli from ORNL for assistance with pilot-plant performance studies
- Dr Alan Winterberg for MP-CARPT development
- Dr Khursheed Karim and Rebecca Hoffmann for conducting lab-scale performance studies at WUStL
- DOE for funding (DE-FC36-01GO11054)