

Refereed Proceedings

Heat Exchanger Fouling and Cleaning:

Fundamentals and Applications

Engineering Conferences International

Year 2003

Comparison of Crude Oil Fouling Using
Two Different Probes

A. P. Watkinson
The University of British Columbia

This paper is posted at ECI Digital Archives.
<http://dc.engconfintl.org/heatexchanger/32>

COMPARISON OF CRUDE OIL FOULING USING TWO DIFFERENT PROBES

A.P. Watkinson

Department of Chemical and Biological Engineering
The University of British Columbia,
Vancouver, B.C. V6T 1Z4 Canada
apw@chml.ubc.ca

ABSTRACT

A variety of different fouling rigs, each with its own advantages and disadvantages is available to assess crude oil fouling. In this research, fouling of three crude oils are compared, using two electrically heated annular probes with strikingly different modes of operation. The Hot Liquid Process Simulator (HLPS) was operated in single-pass mode, under creeping flow conditions for time durations of a few hours at constant surface temperature. The Portable Fouling Research Unit (PFRU) was operated at velocities a factor of 250 higher, and followed the fouling process over two or more days at constant heat flux, using re-circulation of the crude oil. It was of interest to determine whether the two devices led to the same relative ranking of extent or rate of fouling, and exhibited similar responses to changes in surface temperature.

Two conventional light crude oils, and a synthetic crude oil derived from heavy oil were tested at average surface temperatures in the range 225-380°C, and bulk temperatures roughly 100°C lower. With the low velocity probe, typical fouling resistances after four hours were over an order of magnitude higher than for the high velocity probe after 48 hours. Fouling rates were two orders of magnitude greater in the low velocity unit. Some differences in relative ranking of the fouling potentials for the three oils were noted.

INTRODUCTION

The application of experimental laboratory results to process plant situations is one of many issues related to heat exchanger fouling which face researchers and process engineers. For the process engineer, uncertainties are involved in the interpretation of lab results taken at higher severity conditions in order to give accelerated fouling, and from re-circulating flows often in regimes different from those in the plant. For the researcher, issues related to choice of experimental test rig involve the lack of standard equipment; the convenience of handling small versus large quantities of fluids; pressure, temperature and velocity limitations in laboratory equipment; amount of

deposits produced in different types of lab units, and the like.

While a number of reviews and books have covered advantages and disadvantages of various types of fouling rigs, the number of studies where direct comparisons have been made of fouling extent or rates from different types of test rig is limited. Fetisoff, et al. (1982), made comparisons of polystyrene fouling in viscous flow on a coiled wire UOP type probe, at identical heat flux and surface temperature to that in an annular probe (PFRU unit) in turbulent flow. Muller-Steinhagen et al. (1986) continued work using the same probes in particulate fouling. In both these cases, fouling rates were comparable on the coiled wire probe and in the annular probe.

Brons and Rudy (2002) describe the use of the Alcor Hot Liquid Process Simulator (HLPS) electrically heated annular unit to characterize fouling of seven different crude oils. The device was operated at fixed surface temperature with time, such that the amount of heat transferred to the liquid decreased as fouling took place. Among other factors, they demonstrated correlations between asphaltene solubility characteristics and the amount of fouling measured by the reduction in the rise in temperature of the oil in passing through the test unit. They concluded that the HLPS unit is capable of determining relative fouling rates among different crude oils.

As part of a study on fouling of Canadian crude oils (Srinivasan and Watkinson, 2003) using re-circulating flow in an HTRI-type PFRU probe, data were made available to the author from test work carried out using single pass flow through an Alcor HLPS device. Velocity was roughly a factor of 250 different, with the PFRU being operated at 0.75 m/s and the HLPS unit at 0.003 m/s. This provided an opportunity to compare fouling rates and the relative ranking of fouling potential of the three crude oils when measured using the two devices.

EXPERIMENTAL MATERIALS, APPARATUS AND PROCEDURES

Experiments were done using three crude oils, whose properties are given in Table 1. These were all sour crudes, with sulphur content ranging from 1.26 to 3.68 %. The heaviest crude oil had a viscosity at 25°C over twelve times that of the lightest crude oil. The C7 asphaltene contents ranged from 2.1% to 8.6%. Table 2 compares the dimensions of the two fouling test probes, and some other operating parameters.

Table 1 Properties of Crude Oils Tested

Oil	LSB	MDL	CLK
Density (15°C) kg/m ³	853.4	899.4	958.2
Viscosity (25°C) mPa-s	12.7	27.3	157.8
Viscosity (250°C)* mPa-s	0.60	0.99	2.96
C7 Asphaltenes ASTM D3279-97 (wt %)	2.05	5.05	8.58
Organic Sulphur (wt %)	1.26	2.46	3.68
Centrifugal Solids BS&W (vol %)	<0.025	0.1	0.35
API Gravity at 15°C	34.3	25.8	16.2

* estimated

Table 2 Comparison of Dimensions and Operating Parameters for Both Probes

Test Unit	PFRU	HLPS
Heated Rod Diameter (mm)	10.7	3
Heated Length (mm)	102	60
Annulus Outer Diameter (mm)	15.85	4
Pressure (MPa)	1.2	4.2
Typical Heat Flow (W)	1200	5
Typical Heat Flux (kW/m ²)	400	10
Flow Type	Re-circulated	Single-pass
Flow rate (mL/min)	4,830	1.0
Bulk Velocity (m/s)	0.75	0.003
Reynolds No. (at T _f)	1100 -5600	0.3-2
Operating Mode	Constant heat flux	Constant wall temperature

Figure 1 shows sketches of both probes. The procedures used for the fouling experiments for the PFRU are described in the accompanying paper (Srinivasan and Watkinson, 2003). For the HLPS unit tests were done as follows. The flow, pressure and target surface

temperature were selected. Inlet temperatures were typically 74°C, whereas clean surface temperatures at a position of 38 mm into the heating section were set at either 250°C, or 370°C. Once the unit was started, inlet and outlet temperatures were recorded at three different times of 19 minutes, 124 minutes and 244 minutes. At each of these times, an axial profile of the surface temperature was also measured by moving the position of the wall thermocouple along the tube. The data at 19 minutes was taken to represent the clean condition. The unit was operated at a controlled wall temperature, hence as fouling occurred, the heat flow to the fluid decreased, resulting in a decrease in the outlet fluid temperature. A third set-point temperature of 400°C was also investigated ; however in this case, the fluid had made one pass through the unit at a set-point temperature of 250°C, and then was used again with a set-point temperature of 400°C. This was undertaken to better simulate a pre-heat exchanger train where oil is heated to ever rising temperatures through to the furnace inlet temperature.

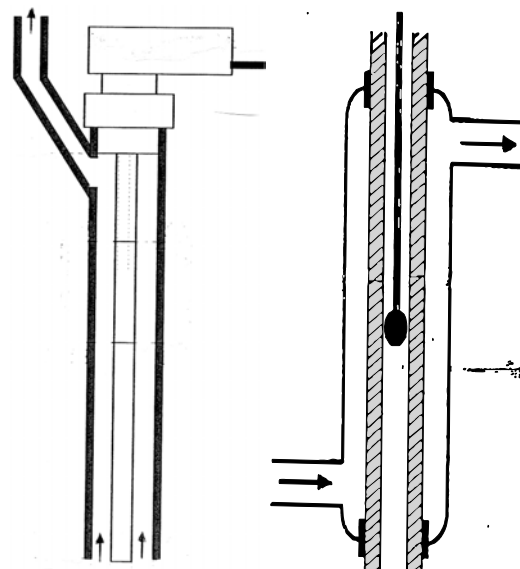

Figure 1: Sketch of PFRU and HLPS Probes

RESULTS AND DISCUSSION

In order to analyse the HLPS data, the axial temperature profiles were first plotted. Figures 2a-c show data for the three oils, at a set point of 250°C at z =38 mm, and Figures 3a-c show results at a set point of 370°C. Surface temperatures increase with axial position, going through a sharp maximum at roughly 40 mm. For a uniform heat flux, and uniform film coefficient, one would expect the

surface and bulk axial temperature data to form straight parallel lines. To determine a heat transfer coefficient under clean or fouled conditions, an appropriate driving force must be defined. As seen in Figure 2, axial surface temperatures were recorded over thirteen positions from

$z = 0$ to $z = 60$ mm. For this work, the average temperature driving force was determined over the central nine axial positions

$$\Delta T_m = \frac{1}{9} \sum_{i=3}^{11} [T_s(z)_i - T_b(z)_i] \quad (1)$$

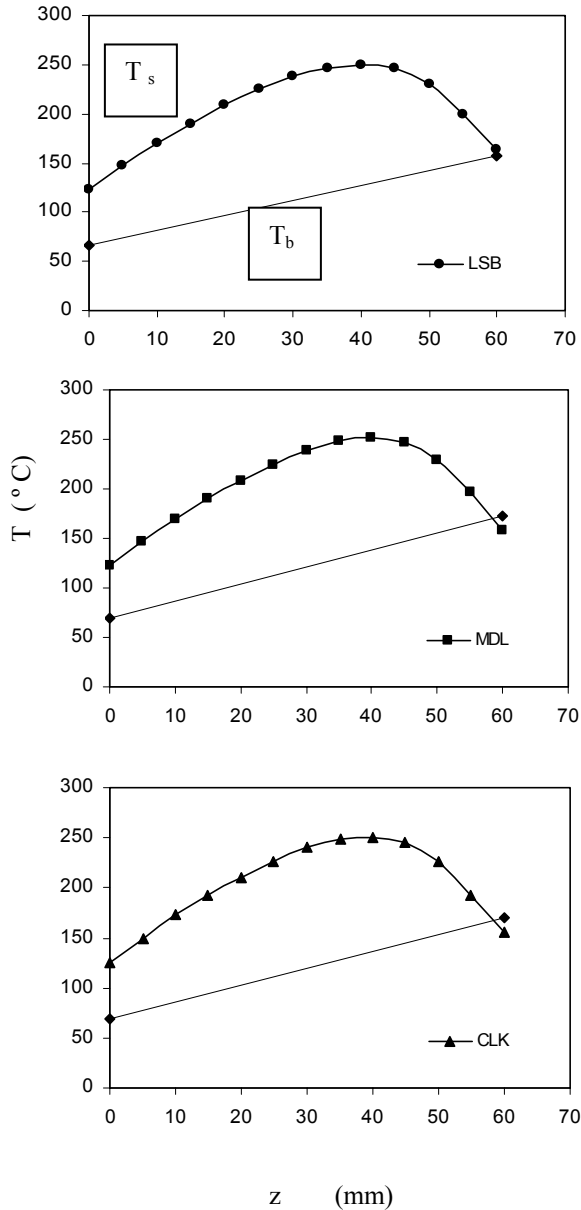

Figure 2 HLPS axial temperature profiles for a) LSB, b) MDL and c) CLK oils at set point temperature of 250°C at $z = 38$ mm.

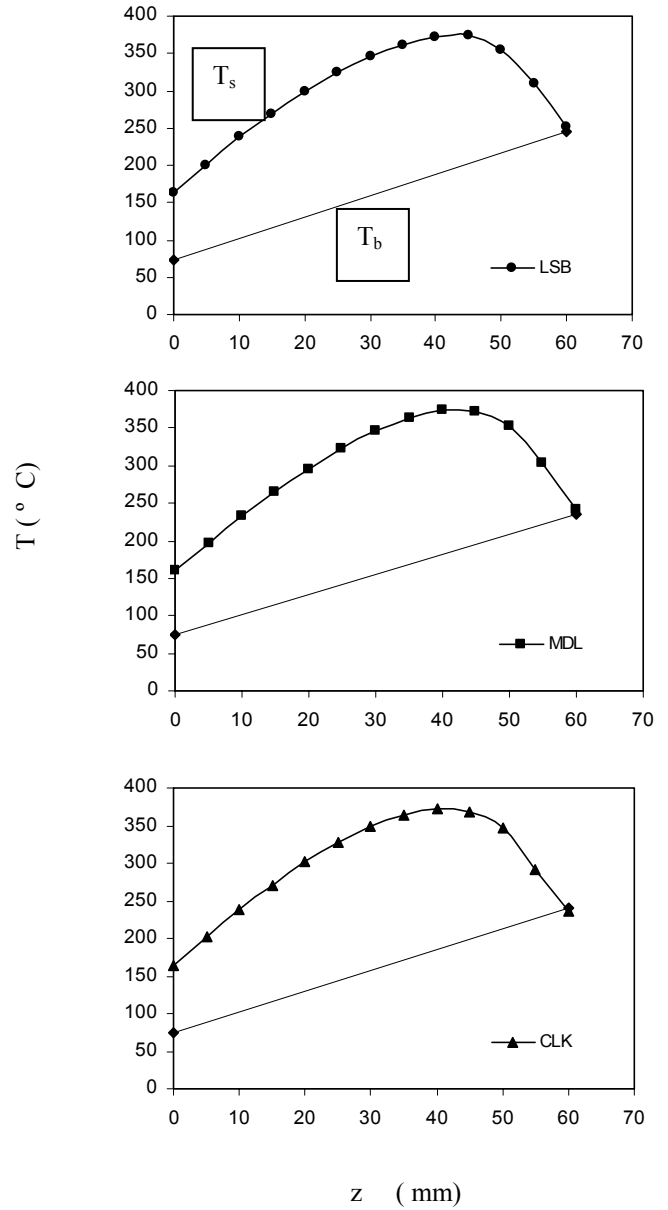

Figure 3 HLPS axial temperature profiles for a) LSB, b) MDL and c) CLK oils at set-point temperature of 370°C at $z = 38$ mm.

Therefore the two end sections each of 10 mm in length were eliminated from the calculations. The bulk fluid temperature was assumed to increase linearly with position. The overall heat transfer coefficient was then determined using the sensible heat gain of the fluid:

$$U(t) = mC_p(T_{b,z=50\text{ mm}} - T_{b,z=10\text{ mm}}) / A \Delta T_m \quad (2)$$

The heat capacity for the oils was taken as

$$C_p = 1.85 + 0.0037 * T_{bm} (\text{°C}) \quad (3)$$

Within the accuracy of the data, the surface temperatures did not change over the four hours of the experiment. The outlet bulk temperature declined by up to 15°C in four hours as a result of fouling at a surface temperature of 326°C. The fouling resistance, R_f was calculated in the usual way, at time about 2 hours, and at about four hours:

$$R_f = 1/U(t) - 1/U_0 \quad (4)$$

Figure 4 shows the R_f versus time plots for the three oils, at the two values of the set-point surface temperatures with single-pass flow. At $T_{sm} = 223^\circ\text{C}$, fouling is evident after two hours for MDL and LSB, and for all three oils after 4 hours. While LSB and CLK showed minor increases in R_f after 2 hours, MDL showed a rapid increase. At $T_{sm} = 326^\circ\text{C}$, all oils showed considerable fouling in 2 hours,

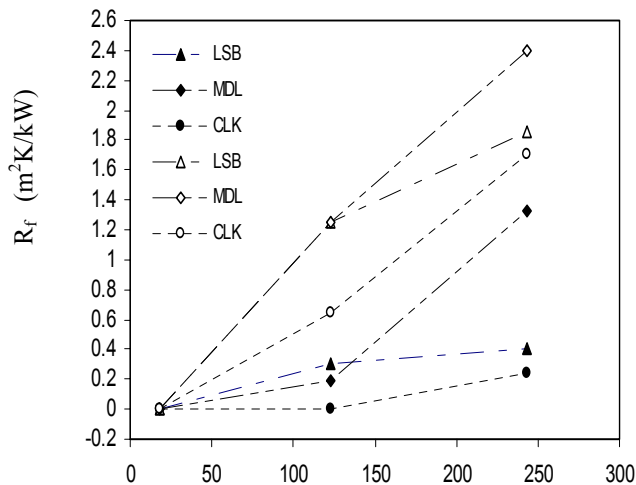

Figure 4 HLPS fouling resistance versus time plots for $T_{sm} = 223^\circ\text{C}$ (solid symbols) and $T_{sm} = 326^\circ\text{C}$ (open symbols)

and further increases by four hours. MDL appears to foul the most after four hours at both low and higher temperatures. After four hours, CLK and LSB appear to

foul to about the same extent, both at low and at high surface temperature, although the extent of fouling is markedly higher at the higher temperature. The fouling resistance values are very large, averaging about $2 \text{ m}^2\text{K/kW}$ at four hours for the higher surface temperature case. Assuming an average deposit thermal conductivity of 0.3 W/m K , this fouling resistance corresponds to a deposit thickness of 0.6 mm , which is essentially equal to half of the gap thickness in the annulus.

Figure 5 shows the data for the total fouling resistance with the 400°C set-point, given by the sum of extent of fouling at 250°C and at 400°C . Behaviour appeared very similar to that in single pass flow, and was subsequently treated in the same manner.

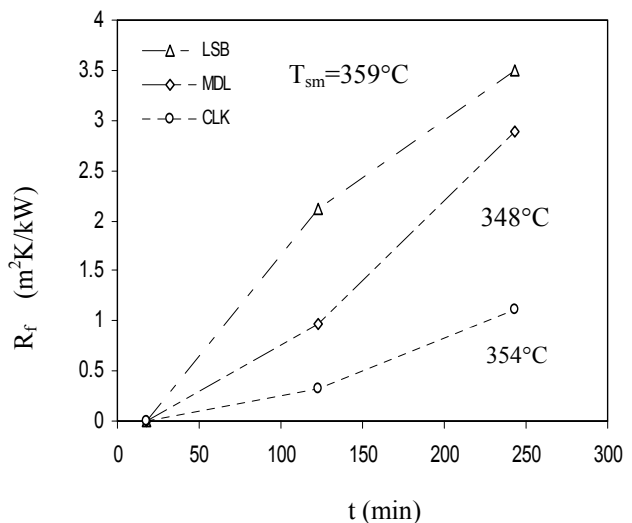

Figure 5 HLPS fouling resistance versus time after first pass flow at $T_{sm} = 223^\circ\text{C}$ and second pass at $T_{sm} = 345\text{--}360^\circ\text{C}$

Average fouling rates and fouling activation energies were calculated for the HLPS probe, in order to make a comparison with data from the PFRU (Srinivasan and Watkinson, 2003). The average fouling rate was determined as the mean value of the rate over the first two hours, and that over the total four hour period. Rates were not constant with time in all cases (Figures 4, 5), nevertheless this procedure appeared to yield meaningful results, particularly for the higher temperature data sets.

Fouling activation energies determined for the three temperature conditions are reported in Table 3. Values of fouling activation energy ranged from 28 kJ/mol for MDL to 38 kJ/mol for CLK, based on either film or surface temperature. In the PFRU unit, the value for LSB oil based on standard film temperature was 66 kJ/mol . The

fouling activation energy may reflect steps such as transport and adhesion as well as chemical reaction, and hence values for the two probes should not necessarily be the same. For the HLPS, values are significantly lower than for the PFRU.

Table 3 Fouling Rates and Activation Energy for the HLPS

Oil	T ₃₈ °C	Avg. Rate 10 ⁴ m ² K/kJ	T _{sm} °C	T _B °C	T _f °C	E _f kJ/mol
CLK	250	0.16	223.6	120	171.8	
	370	1.0	326.4	157	241.7	38
	400	0.84	353.7	193	273.4	
LSB	250	0.35	223.6	112	167.8	
	370	1.5	326.6	160	243.3	36
	400	2.4	359.4	185	272.2	
MDL	250	0.6	222.8	120	171.4	
	370	1.7	325.1	155	240.0	28
	400	2.2	347.6	185	266.3	

Magnitude of Fouling Rates

Figure 6 makes some comparisons of fouling rates and conditions in the two experimental units. For the HLPS, (Figure 6a) fouling rates were of the order of 160 to 2400 E-07 m²K/kJ, whereas for the PFRU, values were in the range 2 to 10 E-07 m²K/kJ, i.e. rates at a given film temperature were about 100-500 times larger in the HLPS, than in the PFRU. Bulk velocities were about 250 times higher in the PFRU. The product of velocity and fouling rate was essentially the same for both units. The flows in the two probes are in different regimes (Table 4). The PFRU was operated at Reynolds numbers of 1400 for CLK, and below 6000 for both MDL and LSB. For the HLPS, Reynolds numbers were of the order of unity. Epstein (1983) indicated that with surface reaction control for an n-th order irreversible reaction in hydrodynamically developed laminar flow, the fouling rate should be inversely proportional to bulk velocity. Deposit analyses given in Srinivasan and Watkinson (2003) do suggest chemical reaction fouling. The relative fouling rates for the two probes can possibly be rationalized on this basis, although the flow conditions in the PFRU may not meet the above condition. Reynolds numbers based on average bulk temperature are considerably lower than those in Table 4. Calculations show that the HLPS was operating in flow dominated by laminar free convection, with Gr/Re² of the order of 80 whereas for the PFRU, this ratio was of the order of 10⁻⁴. The PFRU has a clean heat transfer coefficient some 40-60 times that of the HLPS.

Table 4 Comparisons of Rates and Operating Parameters

Unit	Oil	T _{f,0} °C	10 ⁻⁷ Rate m ² K/kJ	U ₀ kW/m ² K	Re (at T _f)	Gr
HLPS	LSB	243	1500	0.074	2.0	336
	MDL	240	1660	0.068	1.2	109
	CLK	242	1000	0.070	0.34	9.3
PFRU	LSB	310	4	4.6	5600	7320
	MDL	310	4.5	4.6	3700	3060
	CLK	310	9	3.1	1400	420

Ranking of Oils in Terms of Fouling

Figure 6a, indicates that when using the HLPS probe, fouling rates of the lighter two oils MDL and LSB are about the same, except at low temperature, where MDL may be higher. Figure 6b which shows data for the PFRU all taken at a fixed velocity, also shows that MDL and LSB fouling rates are about the same, except possibly at very low temperatures, where fouling rate with MDL may be higher. Hence the two fouling probes show the same relative ranking of the two lighter oils. Using the PFRU, at 1.68 < 1000/T_f (K) < 1.8, the fouling rate of CLK is roughly constant, and with the HLPS the same constancy of fouling rate with temperature is found over the range 1.8 < 1000/T_f < 2.0. However, for the PFRU at the conditions used, the fouling rate of CLK is higher than LSB and MDL. This may be related to the fact that the less viscous oils are both in the transition-turbulent regime, whereas CLK is in the viscous regime (Re~1500). For the HLPS unit, where all three fluids are in the same regime, the fouling rate of CLK is below that of LSB and MDL for two of the three tests. This is somewhat surprising, as the BS&W levels for CLK are higher than for the other two oils (Table 1). Additional experiments are needed to clarify the reasons for these differences.

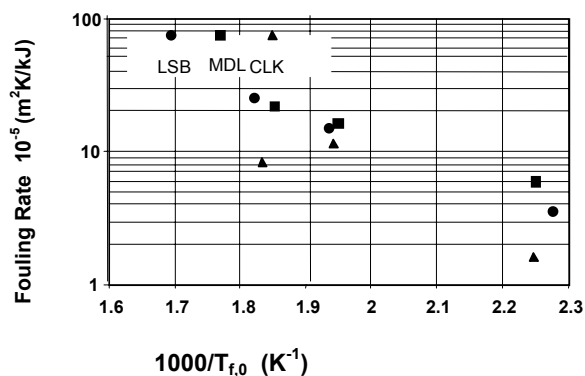

a) HLPS

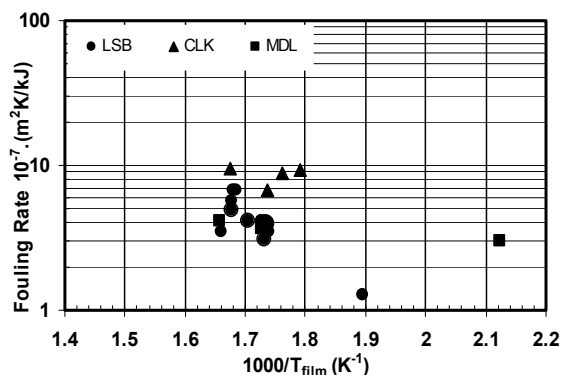

b) PFRU

Figure 6 Fouling Arrhenius Plot based on Film Temperatures for Activation Energy using a) HLPS and b) PFRU

CONCLUSIONS

Fouling of three crude oils was compared in two annular probes. Re-circulating flow over 48 hours at Reynolds numbers of about 1500-6000 was used in the PFRU, whereas single pass creeping flow ($Re \sim 1$) was used in the HLPS over fouling periods of 4 hours.

At similar film temperatures, fouling rates were roughly a factor of 250–500 higher in the HLPS, where the velocity was about 250 times lower and heat transfer appeared to be dominated by natural convection. These findings are consistent with chemical reaction fouling in laminar flow.

The two less viscous oils had fouling rates similar to each other in both units. At fixed velocity, the most viscous oil showed higher fouling rates than the other oils in the PFRU, and lower fouling rates in the HLPS.

Further research is needed to clarify the comparisons of fouling rates under these two markedly different operating regimes.

ACKNOWLEDGEMENTS

Ongoing financial support was provided by the Natural Sciences and Engineering Research Council of Canada. Data and oil samples were provided by W. Power of Shell Canada Ltd.

NOMENCLATURE

A	surface area for heat transfer	m^2
C_p	heat capacity of fluid	$kJ/kg\cdot K$
E	fouling activation energy	kJ/mol
m	mass flowrate of oil	kg/s
R_f	fouling resistance	m^2K/kW
t	time	s
T_b	bulk fluid temperature	K
T_f	film temperature	K
T_m	mean temperature difference	K
T_s	surface temperature	K
T_{38}	set point temperature at $z = 38$ mm	K
U	heat transfer coefficient	kW/m^2K
z	axial position along heated surface	m

Dimensionless Groups

Gr	Grashof number based on equivalent diameter
Pr	Prandtl number based on film temperature
Re	Reynolds number based on film temperature and equivalent diameter

Acronyms

BSW	Bottom sediment and water
CLK	Cold Lake crude oil
HLPS	Hot liquid process simulator probe
LSB	Light Sour blend crude oil
MDL	Midale crude oil
PFRU	Portable fouling research unit probe

Subscripts

bm	Mean bulk value
0	Clean conditions, at time zero
sm	Mean surface value

REFERENCES

- Brons, G. and T.M. Rudy "Fouling of Whole Crude Oils on Heated Surfaces" in Heat Exchanger Fouling-Fundamental Approaches and Technical Solutions, H. Muller-Steinhagen (Ed.), Publico Publications, Essen Germany 2002, pp 249-257.
- Epstein, N. "Fouling Models-Laminar Flow" in Low Reynolds Number Flow Heat Exchangers, Kakac, Shah and Bergles (Eds.), Hemisphere Publ. Co. 1983, pp 965-971.
- Fetisoff, P., A.P. Watkinson and N. Epstein "Comparison of Two Heat Transfer Fouling Probes" Proc. 7th Int'l Heat Transfer Conf., Munich Vol. 6, pp391-396, Paper IH-7, Hemisphere Publ. Co. (1982).

Muller-Steinhagen, H., F. Reif, A.P. Watkinson and N. Epstein “Particulate Fouling under Boiling and Non-boiling Conditions” Proc. 8th Int’l Heat Transfer Conf., San Francisco, Vol. 5, pp2555-60, Hemisphere Publ. Co., (1986).

Srinivasan, M. and A.P. Watkinson “Fouling of Some Canadian Crude Oils” Pre-print ECI Conference Heat Exchanger Fouling and Cleaning, Santa Fe, New Mexico, USA, 18-22 May 2003