

Proceedings
Geohazards

Engineering Conferences International

Year 2006

Instrumentation of Flexible Buried
Culvert Subjected to Rockfall Loading

R. Ebeltoft*

J. O. Larsen[†]

S. Nordal[‡]

*Norwegian University of Science and Technology, roger.ebeltoft@vegvesen.no

[†]Div. of Construction Engineering, UNIS, The University Centre in Svalbard,
JanL1@unis.no

[‡]Division of Geotechnical Engineering, Norwegian University of Science and Technology,
steinar.nordal@ntnu.no

This paper is posted at ECI Digital Archives.

<http://dc.engconfintl.org/geohazards/8>

Instrumentation of flexible buried culvert subjected to rockfall loading

R. Ebeltoft¹, J. O. Larsen² and S. Nordal¹

¹Division of Geotechnical Engineering, Norwegian University of Science and Technology, Høgskoleringen 7a, NO-7491 Trondheim, Norway, PH +47 73594596, FAX +47 73594609; email: roger.ebeltoft@ntnu.no, steinar.nordal@ntnu.no

²Div. of Construction Engineering, UNIS, The University Centre in Svalbard, PB 156, NO-9171 Longyearbyen, Norway, PH +47 79023344, FAX +47 79023301; email: JanL1@unis.no

Abstract

Natural hazards, like avalanches and rock falls, will always be a major concern for infrastructure, i.e. roads and railways, in mountain areas. Several measures are available to protect this infrastructure, but especially in areas with steep slopes, rockfall- or avalanche galleries are commonly used. These structures, which are made to withstand high impact forces, can be made of reinforced/pre-stressed concrete culverts covered with soil. A possibly cheaper and equally safe alternative could be to use a buried corrugated steel culvert.

To investigate the use of buried corrugated steel culverts as rock fall protection structures an experimental study has been carried out. A 4.0 m span half arch corrugated steel culvert was buried in soil and instrumented during rockfall loading. Rock blocks with various weights have been dropped from different heights on a corrugated steel culvert covered with a cushion material. Tests were conducted with dense backfill in near zone and regular backfill in the cushion layer zone.

Measurements were made during both construction phase and during rockfall phase. During construction phase measurements were made to monitor culvert shape and culvert strains. During impact loading from rock blocks decelerations and transmitted accelerations were monitored together with change of culvert shape and deformations. Deceleration of the rock blocks was also documented with a high speed camera.

The goal of this study were to obtain knowledge which can be used in design codes in the future for flexible rockfall- and avalanche shelters.

Rockfall hazard and mitigation measures

Protection of roads and other infrastructure in mountainous areas, particularly from rockfall, have received considerable attention for the past two decades. Rockfall mitigation measures become relevant in situations which may be described by the following:

- There must exist fractured and unstable rock mass, or rock mass which can become unstable
- Rockfall can be triggered

- The slope below the source must be inclined such that it allow for acceleration of rockfall
- A sensitive object is within the range of the rockfall
- Rockfall represents an unacceptable risk for the object

Presently, the common mitigation measures used to protect against rockfall can be categorized as active or passive mitigation measures:

- 1) Active measures are typically: scaling, anchoring, netting, shotcrete sealing or covering of rock surface
- 2) Passive measures are typically stops or rockfall diversions like berms, ditches, barriers or galleries.

In this study, a particular type of passive mitigation measure has been considered. This is a buried flexible culvert with a cushion layer cover. A rockfall can produce very high impact energies, these energies are governed by the velocity of the fall and the mass of the rock. The cushion layer, according to Pichler et al. (2005), has the function of being an energy absorber and to distribute the forces on the structure. Thus the forces developed and the corresponding penetration depths are not only dependent on the mass and velocity, but also the properties of the cushion material (Jacquemon, 1999).

Within the literature, a limited number of experimental studies have been found, that investigate the behaviour of rigid concrete protection structures with a cushion layer subjected to vertical, and also inclined, rock fall loading (Labieuse et al., 1996; Descoedres et al., 1997; Montani Stoffel et al., 1999; Kishi, 1999). Investigations have also been done with respect to penetration depth of a cushion layer consisted of gravel (Pichler et al., 2004).

Despite this work, there is a lack of measurements for rock impacting buried flexible protective structures, for instance steel culverts. The present study deals with a protection system based on a buried steel structure in order to investigate the possibilities for future application as rock fall protective structures. Understanding the dynamic soil-structure interaction is necessary to improve the design of buried structures that are likely to be subjected to impact loadings like rockfall. Flexible culverts show different energy absorption and load carrying capabilities compared to a rigid structure, and there are limitations in how much impact energy these structures can withstand.

To study this behavior a full-scale buried steel culvert subjected to rockfall loading was built and instrumented at Rombakken stone-crushing plant in Narvik, Norway. This paper present the instrumentation and some preliminary results from this full-scale test. The aim of this study is to obtain qualitative and quantitative data. Acquired data were compiled into MATLAB, which act as the database-tool, from which further analyses could be performed to investigate the use of buried steel culverts as rockfall protection structures.

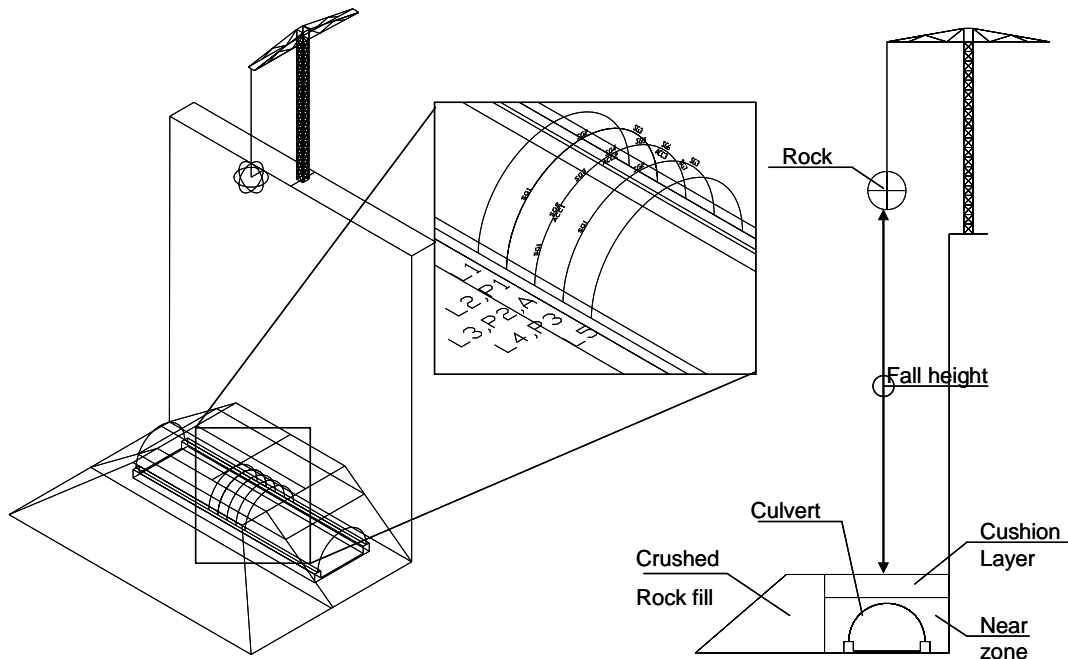

Figure 1: Illustration of experimental setup. Inset shows the different profiles where measurements were carried out.

Test description

Experimental set-up and rockfall loading

The 15.0 m long structural plate metal arch culvert was installed on a reinforced concrete plate foundation, Figure 1. 80-200 mm size compacted gravel was used as backfill at the ends.

The MP200 Arch type metal culvert (Asset International, 2002) was used, which is a galvanized corrugated circular steel arch with a 4.00 m span at the foot and a 1.93 m total rise. The culvert was manufactured from structural plates with 200 x 55 mm corrugations. The plate thickness was 5.0 mm.

The culvert was backfilled. Backfill material in the near zone consisted of 8-16 mm gravel. The outer zone consisted of 23-64 mm size gravel. Confinement of the gravel consisted of rock surface on one side and an 80-200 mm size gravel on opposite side.

During the construction sequence backfill material was placed in 300 mm thick layers and compacted. This procedure was commenced until 300 mm above crown. The remaining cushion material was placed in 600 mm layers without compaction.

After completion of installation impact load tests were conducted. In the present study, natural rock boulders have been used, and the impact of these rocks are centered above the crown of the culvert. After each impact test the cushion layer was removed and replaced to same level. Figure 1 represents the experimental setup.

Instrumentation

Figure 2a) shows the accelerometer device that was fitted with a wireless MicroStrain V-link data acquisition system. The accelerometers used were IC Sensor model 3031-100.

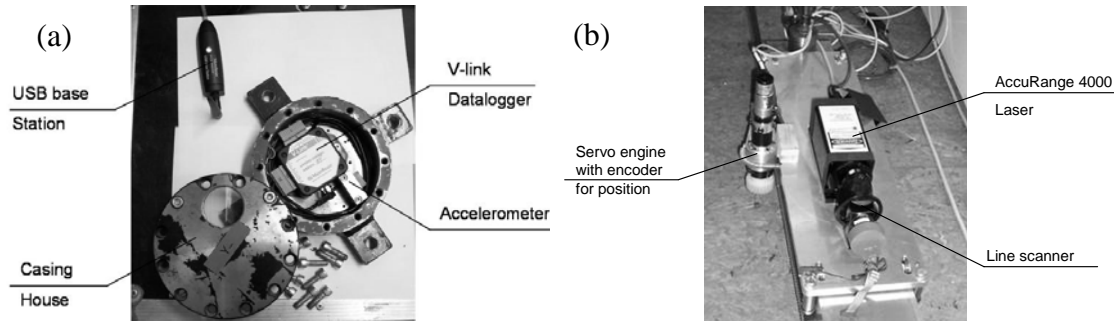

Figure 2: (a) Accelerometer device used to acquire deceleration history of rock impact, (b) laser device used to detect deformations of the culvert.

Each rock block was successively equipped with this device to measure the deceleration history in three directions. Three accelerometers were installed inside the culvert to measure transmitted accelerations. The accelerometers used were PCB Piezotronics model 353B03. These were installed at profile A, as shown in Figure 1. Strain gages were installed as Wheatstone half bridges. A total of 40 strain gages were installed in the corrugated culvert. These consisted of both the glue type HBM LY61-6/350 and the weldable type LS31-6/350. Strain gages were installed at profiles P1-P3. Installation was conducted as described in Webb et al. (1999). A Phantom v5 high-speed camera was used to observe the impact of the rock blocks onto the soil cushion layer.

Figure 2b show the laser device, AccuRange 4000 equipped with a rotating line scanner, which was mounted on an automated wagon to obtain deformations while construction and during the impact tests (Webb et al., 1998). During construction, after placement of each layer, the laser wagon was used to monitor the profiles L1-5 as described in Figure 1. The electrical servo engine had an encoder that ensured the position of the laser device in the longitudinal direction. After impact tests the laser device was also used to monitor the same profiles to detect permanent deformations of the culvert.

Data acquisition and database storage

The signals from the accelerometer mounted on the rocks were acquired with the wireless MicroStrain V-link data acquisition system (Microstrain Inc, 2004). A sampling rate of 2048 Hz was used.

Images from the Phantom v5 high-speed camera were acquired with the phantom camera software system (Vision Research Inc, 2004). A sampling rate of 400 frames per second was used, with a resolution of 1024x512 pixels.

The signals from the accelerometers were conditioned with PCB signal conditioner model 482A22 and readings from strain gages mounted inside the culvert and from the laser device (Aquity Research, 2004) were acquired with HBM amplifier type

Spider 8 and measurement software Catman Pro (HBM, 2005). A sampling rate of 1600 Hz was used.

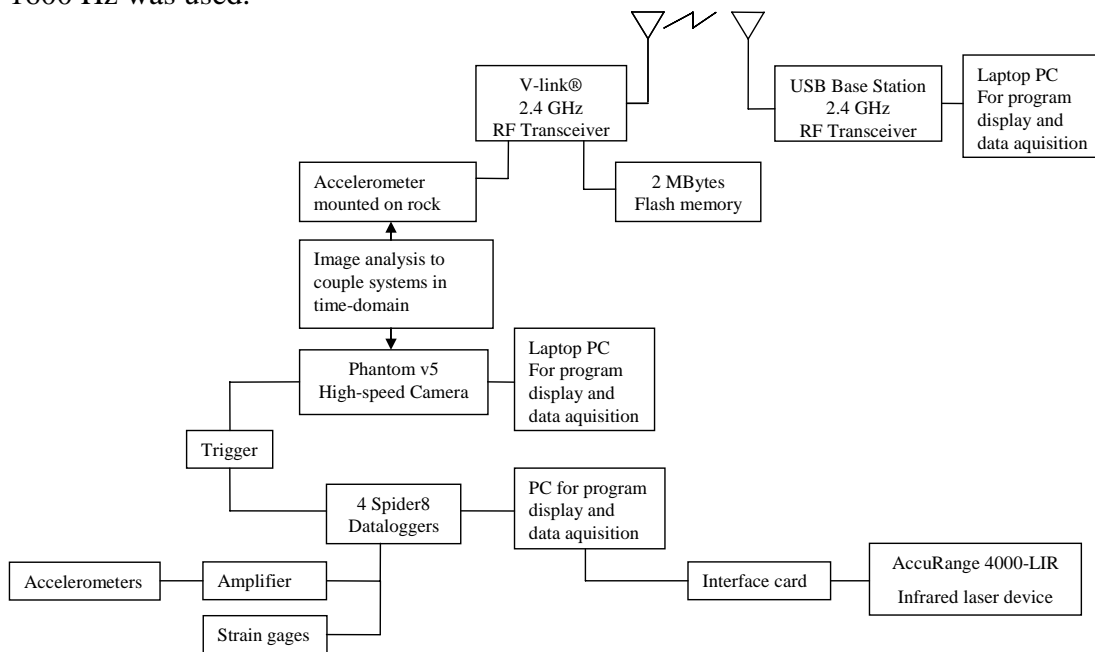

Figure 4: Schematic layout of data acquisition system.

A trigger system ensures that the high-speed camera, accelerometers and strain gages were started simultaneously. Due to the independence between the V-link acquisition system and the Spider 8 acquisition system, image analysis was performed on the high speed images to correlate the deceleration history of rock and the rest of the system.

The recorded data were compiled into MATLAB data structure and processed before being used for analysis. Processing involved eliminating initial zero error in the signals and filtering to remove high frequency noise. Filtering of signals was performed to eliminate frequency content above 500 Hz. Accelerometer readings were calibrated to obtain the acceleration in term of g (i.e. relative to 9.81 m/s^2).

Sample of experimental results

All sample data have been processed in MATLAB, i.e. penetration depths, deceleration history of impact, strain during impact and transmitted accelerations in the culvert. Sample results given below, except from the part about penetration depth, are from a low-energy impact, which consist of a natural rock with mass 200 kg and drop height 5 m. Only a few results are presented in this paper, however some more detailed results are available in (Ebeltoft, 2006).

Penetration depth

Figure 5 present observed penetration depths from the rock fall testing. Penetration depth was measured by means of a stadia rod. As shown in figure the penetration depths (15-32 cm) is increasing with the increasing mass and fall heights. This also indicates high energy dissipation with increasing impact loading.

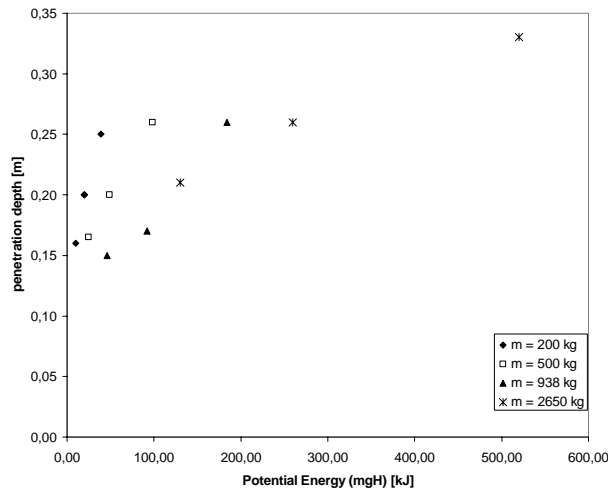

Figure 5: Penetration depth vs Energy for rockfall tests with rock masses of 200, 500, 938 and 2650 kg. Fall heights varying from 5, 10 and 20m.

Deceleration history of rock fall impact

Figure 6 present a typical vertical deceleration history from the rockfall impact tests. Duration of this impact is in the order of approximately 40 ms. Measured peak acceleration is approximately 90 g.

Accelerations

Figure 7 show a typical measurement of transmitted accelerations occurring in the culvert during impact. The figure shows that the impact load generates downward accelerations at the crown (ACC2) of the culvert, and outward accelerations for the other accelerometers (ACC1 and ACC3). The impact generate an oscillation that is highly damped and lasts for only about 100 ms. The energy of the impact is in part absorbed by the soil cushion and in part transmitted through the soil and the structure to the surroundings.

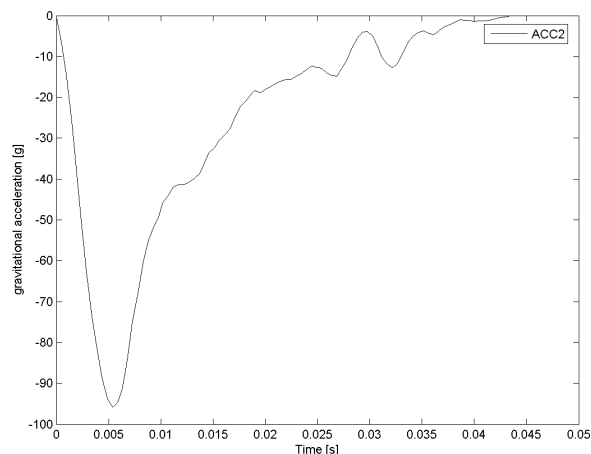

Figure 6: Typical deceleration history of low-energy rockfall impact.

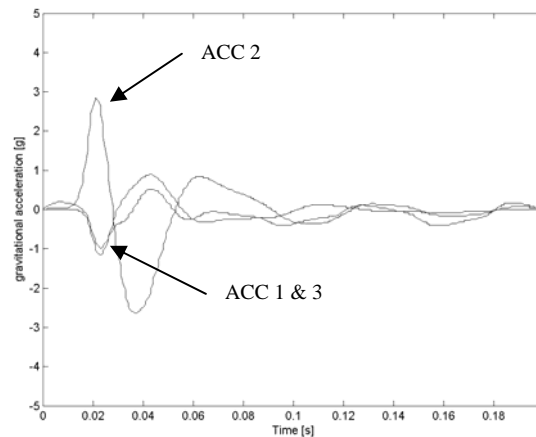

Figure 7: Measured accelerations in the culvert at profile S2 during impact.

Dynamic strains

Figure 8 shows a typical measurement of dynamic strains during a low-energy impact. Initial strains during construction phase have been reset to zero. Measured axial strains, presented in Figure 8(a), show that most of the structure is compressed during impact. Figure 8(b) show bending strains during impact where positive strains are inward bending, while negative strains are outward. This is characterized as a small depression at the crown, while the sides are deflecting outward.

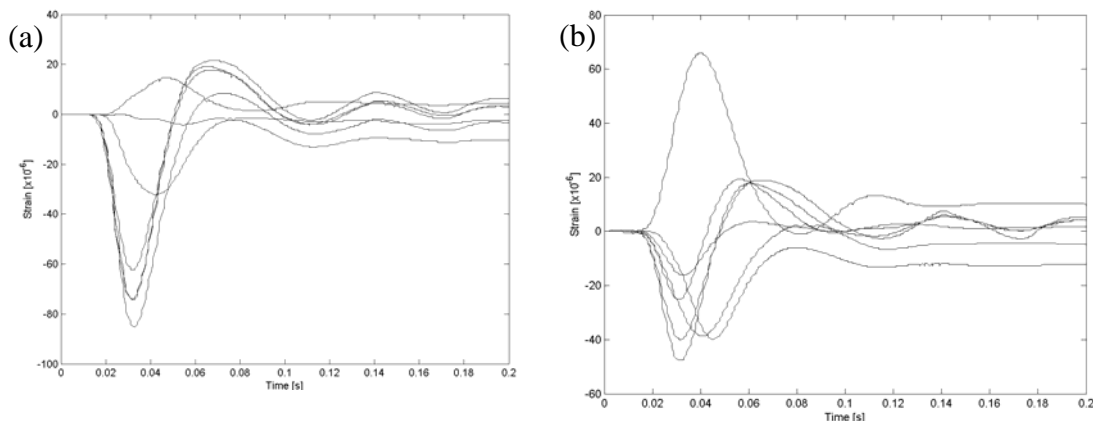

Figure 8: (a) Measured axial strains for the culvert at profile P2 during impact and (b) bending strains for the culvert at profile P2 during impact.

Ongoing work

A considerable amount of data has been collected during the field tests and so far only a limited amount has been interpreted and studied in depth. This work continues and is about to be supplied by numerical simulations and comparison between measurements and calculations.

Summary

In this paper a brief description of the instrumentation of a full-scale buried flexible culvert subjected to rock fall is provided, together with details of experimental set-up

and instruments that were used. A short description of how the recorded data were stored and compiled into a MATLAB database is given. Only a few results are processed so far and some are presented herein. More data are currently being processed and will be available shortly.

Thus, a database of test results have been collected which can be analyzed further to investigate the behaviour of buried flexible culverts during impact from rock falls.

The aim is to propose design requirements for buried corrugated steel structures used to protect roads which is subjected to rock falls.

Acknowledgements

Authors are grateful to acknowledge the Norwegian Public Roads Administration for financial support. Kjell Roksvåg, Einar Husby and Frank Stæhli from Norwegian University of Science and Technology (NTNU) are also acknowledged for their assistance both during construction and testing. The full-scale tests were conducted in a stone-crushing plant owned by Rombakken Pukkverk, Narvik, Norway, with Betongrenovering AS carrying out the construction work. The authors also wish to thank the International Centre for Geohazards (ICG) and the Research Council of Norway for supporting this research

References

- Descoedres, F. (editor) (1997). Steinschlag, Mitteilungen der Schweizerischen Gesellschaft für Boden- und Felsmechanik [Rockfall, Publications of the Swiss Association for Soil- and Rock Mechanics], Vol. 135. In German and French.
- Ebeltoft, R. (2006) "Behavior of buried flexible culvert subjected to impact load by rock falls" Tech. Rep., NTNU
- Jacquemond, J. (1999) "Swiss guideline for the design of rockfall protection galleries: Background, safety concepts and case histories" Joint Japan-Swiss scientific seminar on impact load by rockfall and design of protection structures" Kanazawa, Japan.
- Kishi, N. (1999) "Absorbing performance of sand cushion and three-layered absorbing system" *3rd Asia Pacific Conference on Shock and Impact loads on Structures*, Singapore.
- Labieuse, V., Descoedres, F. & Montani, S. (1996). "Experimental study of rock sheds impacted by rock blocks" *Struct. Engrg. Int.*, 6 (3), 171-76.
- Montani Stoffel, S., Labieuse, V., Descoedres, F. (1999). "Vertical and Inclined impacts of rock blocks on a rock shed model" *9th Int. Symp. on Rock Mech.* ISRM, Paris, Août.
- Pichler, B., Hellmich, C., Mang, H. A. (2005). "Impact of rocks onto gravel. Design and evaluation of experiments" *Int. J. Impact Engnr.*, 31, 559-578.
- Webb, M.C., Selig, E.T., and McGrath, T.J., (1999) "Instrumentation for monitoring large-span culverts" In *Field Instrumentation for Soil and Rock, ASTM STP 1358* (G. N. Durham and W. A. Marr, eds.), American Society for Testing and Materials.