

## **PLATONIC PUBESCENCE: THE INSTRUCTIONAL COMPUTER COMES OF AGE**

*M. Keith Myers, University of Illinois*

Computers have been used as instructional devices at least since 1959. Preliminary evaluations as to whether such a teaching aid is effective in the area of foreign language instruction are being made or have been completed at several universities and military installations (1). The chief gains which CAI experiments here and elsewhere seem to point to are the achievement of an increased overall efficiency in the management of time devoted to instruction, the shorter time required by the student to "learn" the subject matter, and some increase in long-term retention of content (2). At the present time, the cost per student-hour at a CAI terminal is the crucial factor. Computers *can* assist instruction effectively, but can we afford them?

Daniel Alpert, Dean of the Graduate College of the University of Illinois, and Donald L. Bitzer, Director of the Computer-based Education Research Laboratory there, believe we can. They predict that in a few years the cost for an hour of instruction at a CAI terminal will be about thirty-five cents (2). Their prediction is not a mere wish, but a realistic engineering projection based on a decade of experience.

The CAI installation at the University of Illinois goes under the name of PLATO (Programmed Logic for Automatic Teaching Operations) (3). Work on PLATO I began in 1959; PLATO II began operation in 1962; and PLATO III entered its first phase of operation in late 1964. PLATO will leave its experimental phase in the course of this decade with the completion of the fourth generation of hardware—PLATO IV (2). The first large segment of this 4000 terminal system will be installed in the new Foreign Languages building now under construction. Language laboratories containing 224 terminals, and 32 additional terminals located in offices and seminar rooms throughout the building, are scheduled for installation during 1972 and 1973. Terminals in other places and for other purposes will follow.

### *PLATO Instruction in Languages*

The first students to use the PLATO system in connection with a foreign language course were enrolled in the fall of 1968-69 in three courses: Elementary Latin, Elementary French, and French Phonetics. Professor Richard Scanlan of the University of Illinois Classics Department wrote the materials used in the Latin courses and teaches

## **Instructional Computer**

one of the PLATO sections in Latin. The materials used in the beginning French course have been adapted from texts written by Professor Fernand Marty of Hollins College. About two thousand student-hours of instruction using these materials has been presented on PLATO. Two students have had four consecutive semesters of PLATO French. Only two to three hours at a terminal per week have been available to students in these courses. Due to this restriction, an additional three to four hours of classroom instruction and two hours of language laboratory per week (for the French students) have been required. (On the other hand, very little homework has been assigned.) A one-semester CAI course in French Phonetics is presently being offered for the third time. Forty-one students have taken this course on PLATO.

### *Random Access Audio*

A proposed student terminal for PLATO IV has been described elsewhere (4). What was referred to a year ago as a desideratum, viz., a random-access audio selector, has now become a reality and is ready to undergo a life test.

The following paragraphs are based on the preliminary sketch of an article being prepared for publication by D. L. Bitzer and D. Skaperdas, Associate Director of CERL. They describe in technical terms the first prototype of this optional component of PLATO IV which has been developed here principally for use in foreign language instruction.

The Random-Access Audio Selector is a device which utilizes an economical, durable, 12 inch thin magnetic disk (Mylar base) for storing audio messages.

The location of a message is specified for computer selection by its radial and angular position on the disk and by its duration. There are 64 circular tracks in the present model.

The disk is placed on a turntable which rotates approximately once every 8 seconds. Consequently, there is a total of  $64 \times 8 = 512$  seconds (approximately  $8\frac{1}{2}$  minutes) of recorded audio messages. By increasing the diameter of the disk by one-third, the number of tracks will be doubled and the storage time extended to 17 minutes.

A single magnetic read/write head is attached to the free end of the last piston plunger in a set of six pneumatic cylinders which are mounted serially on a stationary arm (Fig. 1). Fluidic valves control the direction of air being introduced into these cylinders. The movement of the cylinders causes the magnetic head to move in or out radially. The piston or "throw" length of each succeeding cylinder is twice as long as that of the preceding one (Fig. 2).

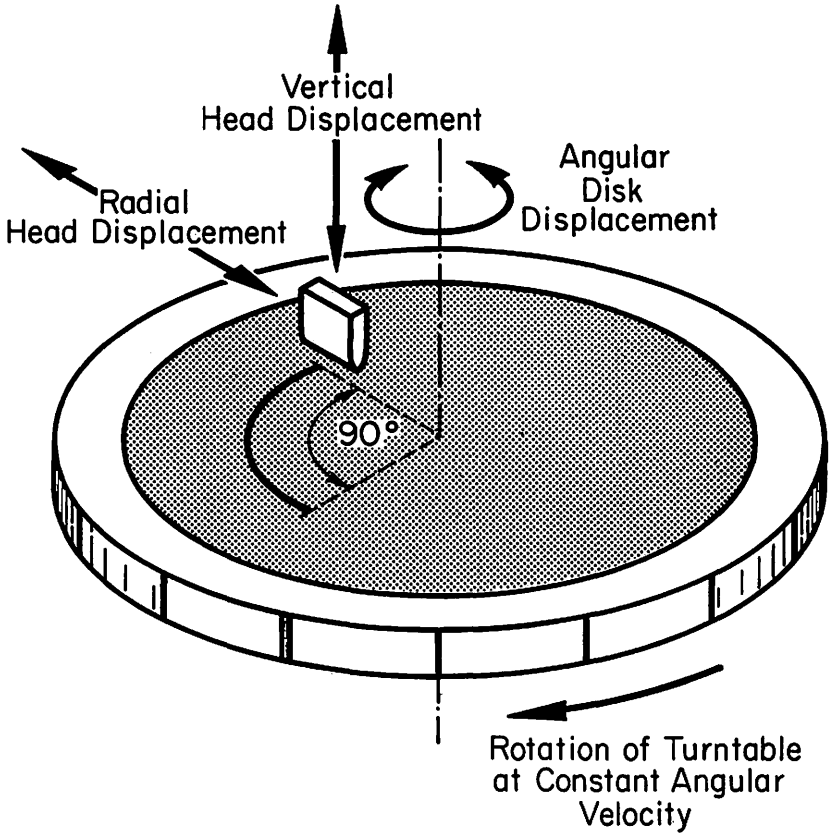

This arrangement allows the magnetic head to move radially to any one of the 64 circular tracks within a range of 0.5 to 1.0 second, depending on the cumulative "throw."

The magnetic disk always rotates with the turntable. In addition, it is coupled through a drive shaft mechanism with a set of 4 pneumatic cylinders mounted serially on another arm. The pur-

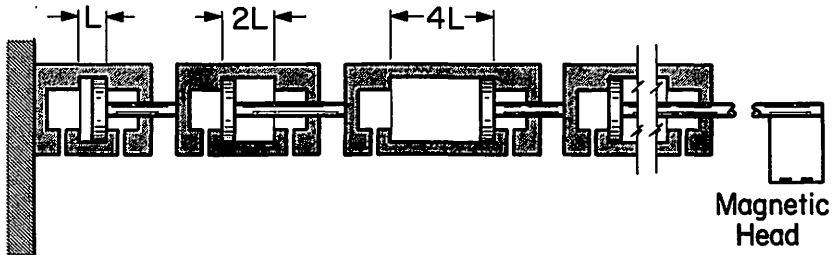

## Instructional Computer

pose of this second set is to angularly displace the magnetic disk with respect to the turntable in order to bring the beginning of a specified sector under the magnetic head (Fig. 3). The amount

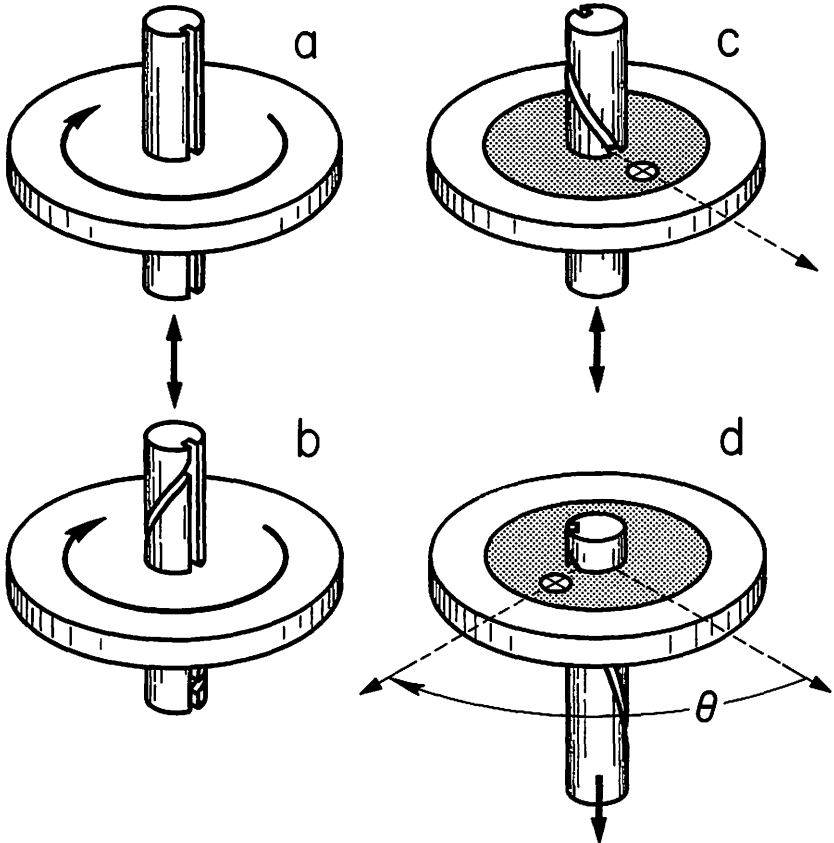

of clockwise or counter-clockwise angular displacement imparted to the disk by the set of 4 pistons is determined by the angular position of the turntable with respect to its base reference mark. This position is ascertained by an optical sensor which reads reference marks located on the outer edge of the turntable. The arrangement of the set of four cylinders permits the selection of any one of 16 sectors of a given circular track, i.e., the selection of any one of 16 one-half second messages. An additional cylinder will increase the number of sectors to 32, allowing for the selection of any one of 32 messages one-quarter of a second in duration and shortening the access time to within a range of 0.1 to 0.5 second. The magnetic head is not in contact with the magnetic disk when

a new location is being selected. It is lowered onto the disk only to play back the desired message, after which it is immediately lifted away from the disk.

A message is defined by stating the location of its beginning point on a given track and its duration. For example, a message on track 25 occupying the 6th, 7th, and 8th sectors is specified by the computer as 25-6-3. The set of six pistons moves the magnetic head radially to the 25th track. Simultaneously the set of 4 pistons moves the disk angularly clockwise or counter-clockwise to bring the beginning of the 5th sector under the head. While this is occurring the turntable continues to rotate. In the present model, the time required for positioning the head and then waiting until it reaches the 6th sector is .5 to 1.0 second. On reaching the marker for the 6th sector, the head is dropped for 3 sectors of playback and then lifted.

### *Nurturing an Adolescent*

High costs have kept CAI safely restricted to a few scattered experimental situations. Now the technology is about to leave its childhood. But handling an adolescent can be a trying business, as most parents of teenagers will testify.

In thinking about Computer-Assisted Instruction as it relates to the teaching of foreign languages, one should place the emphasis on the middle term—"Assisted"—if one wishes to avoid an initially negative reaction and the ensuing development of avoidance behavior with respect to this relatively new educational aid.

In his article, "Sign, Transaction, and Symbolic Interaction in Culture Mediation" (5), W. D. Stevens characterizes quite succinctly the type of system under discussion here.

"The computer-tutor is a computer-controlled man-machine input-output teaching apparatus with typewriter or other console and audio-visual-lingual display facilities programmed for stimulus-response-feedback-correction sequences to achieve specific instructional objectives."

Stevens includes the computer-tutor in a group of culture mediators where it ranks favorably with the more familiar mediators such as teachers, peers, siblings, father, and mother.

All these culture mediators, with the exception of the mother, are classed together by Stevens as *multi-sensory* in their capacity for engaging the learner in various modes of transaction with the environment. The mother (or mother surrogate) stands out here as the one and only *omnisensory* culture mediator in that, in her case, all transactional modes are operative: gustatory, olfactory, tactile-kinesthetic, visual and audio-visual.

## **Instructional Computer**

Stevens reminds us that a qualitative difference exists between human-machine transactions and interpersonal ones. In other words, competent teachers need have no fear of being replaced by a machine.

### *References and Notes*

1. viz., CAI installations at Stanford University, SUNY at Stonybrook, the Naval Academy, and the Defense Language Institute.
2. Alpert, D. and Bitzer, D. L., "Advances in Computer-Based Education." *Science*, March, 1970.
3. The PLATO Project has been supported in part by the National Science Foundation, the Advanced Research Projects Agency, the Joint Services Electronics Program of the Department of Defense, and the Department of Health, Education, and Welfare.
4. Myers, M. K., "Essential Components of a Student CAI Terminal," paper presented at AAAS Meeting, Dallas. 1968.
5. Stevens, W. D., "Sign, Transaction, and Symbolic Interaction in Culture Mediation," *AV Communication Review*. (Summer 1969).