



# EDUCATIONAL POLICY AND RESEARCH

*Monographs and Studies of the Jagiellonian  
University - Institute of Public Affairs*

**EDITED BY  
HASAN ARSLAN  
ROMAN DORCZAK  
DRAGOESCU URLICA ALINA-ANDREEA**

**Monographs and Studies of the Jagiellonian University  
Institute of Public Affairs**

---

# **Educational Policy and Research**

**Edited by  
Hasan Arslan  
Roman Dorczak  
Dragoescu Urlica Alina-Andreea**

---

**Kraków 2018**

The publication was financed from the funds of the Jagiellonian University Faculty  
of Management and Social Communication

**Reviewer:**

Dr. Rafał Otręba , University of Economics in Katowice

---

**Series editing:**

Chief Editor: dr hab. Ewa Bogacz-Wojtanowska, prof. UJ

Secretary: dr Wioleta Karna

**Scientific Council:**

prof. dr hab. Łukasz Sułkowski - Chairman

prof. dr hab. Aleksander Noworól

dr hab. Grzegorz Baran

dr hab. Zbysław Dobrowolski, prof. UJ

dr hab. Roman Dorczak

dr hab. Dariusz Grzybek

dr hab. Sławomir Magała

dr hab. Grzegorz Mazurkiewicz

prof. dr hab. Grażyna Praweńska-Skrzypek

prof. dr hab. Andrzej Szopa

---

**Publisher:**

Jagiellonian University Institute of Public Affairs

ul. prof. Łojasiewicza 4, 30-348 Kraków

tel. +48 12 664 55 44, fax + 48 12 644 58 59

e-mail: monografia\_isp@uj.edu.pl

www.isp.uj.edu.pl

ISBN: 978 - 83 - 65688 - 34 - 7

ISBN: 978 - 83 - 65688 - 35 - 4 (e-book)

© Copyright by the Institute of Public Affairs

Jagiellonian University

1<sup>st</sup> Edition, Kraków 2018

This publication or any of its fragments may not be reprinted without a written consent of the Publisher.

# Table of Contents

## Educational Policy

*Ezgi Gol, Hasan Arslan*

The Internationalization Standards in Education and International Schools in Turkey .....9

*Ruken Akar Vural, Nermin Karabacak, Mehmet Kucuk, Senol Sezer, Cigdem Celik*

Assessment of the 6-11 aged Syrian Refugee Children's Educational Needs: A Multidimensional Analysis ..... 19

*Jale Ipek, Duygu Vargor Vural*

Development Of Cognitive Skills Of Hearing Impaired Students .....29

*Soner Polat, Yaser Arslan*

The Impact Of Peace Education Programme At University On University Students' Tendency To Tolerance ..... 41

*Osman Ferda Beytekin, Sekibe Tas*

Instructional Supervision At Secondary Schools .....47

*Sezen Sigin, Adil Adnan Ozturk*

Black Box in Turkish Education System: Prof.Dr. Adil Turkoglu's Life, Pieces and Scientific Contributions .....55

*Burcu Karademir, Adil Adnan Ozturk*

Comparison Of 2004 And 2017 Social Study Programs ..... 63

*Ibrahim Gokdas*

Designing Web-based Situated Learning Environment in Teacher Training .....73

*Bertan Akyol, Bilge Sevim Okuyan, Erhan Coskun*

Investigating The Means Of Providing Vocational School Students With Improved Language-Learning Environments: The Case Of Davutlar Vocational School..... 83

*Ilhan Kulaca, Adil Adnan Ozturk,*

The Village Teacher Training Trials in Turkey, Mahmudiye Instructor Course and Mahmudiye Village Teacher Training School ..... 89

*Ilknur Maya, Necmiye Pamuk*

The Comparison Between Turkey And Some Countries Having High Achievement In PISA In Terms of Gender Equality ..... 97

*Nesrin Ozsoy, Gokhan Kinali, Yildiz Akkaya, Merve Umurbek*

Examination Of The Reasons For The Preference Of Teacher Candidates For The Mathematics Teaching Program: Aydin Case Abstract ..... 107

*Pervin Oya Taneri, Mehmet Mahsum Akgunduz*

What values should be taught? Measuring the Perceptions of High School Teachers on Values Education..... 117

<i>Mehmet Cetin, Adil Adnan Ozturk, Sukran Demirkaya</i> Primary Education Practices of National Education Ministers (1999-2011).....	125
<i>Munevver Olcum Cetin, Ismail Erol, Pelin Karaduman</i> The Opinions Of School Administrators On The Teacher Performance Evaluation .....	133
<i>Ismail Erol, Ismail Karsantik</i> Investigation of Teacher Opinions on Crisis Management in Primary and Secondary Schools .....	143
<i>Bertan Akyol, Mehmet Ulutas</i> Teachers' Perception of Justice in Decision Making Process .....	151
<i>Ismail Erol, Ismail Karsantik</i> The Management of Conflicts among Teams in the School and the Leader's Impact on the Conflict Process .....	161
<b>Teaching And Learning</b>	
<i>Yasemin Abali Ozturk, Cavus Sahin, Mehmet Kaan Demir, Serdar Arcagok</i> An Analysis of Graduate Theses on Elementary Education .....	171
<i>Jale Ipek, Gokben Turgut</i> Coding With Scratch In Primary Education: A Case Study .....	179
<i>Burcu Aydin</i> ESL And EFL Learners' Perceptions Of Effective Foreign Language Teaching .....	189
<i>Mustafa Aydin Basar, Ergun Kaya</i> Students' Thoughts Over Arrangement of Schoolyards .....	197
<i>Deniz Beste Cevik Kilic</i> An Analysis of the Optimum Piano Instructor's Characteristics from Students' Perspective .....	209
<i>Kenan Kangoz, Sultan Baysan</i> The Effect of Using Photos on Academic Achievement and Attitudes in Social Studies Teaching ....	215
<i>Asuman Duatepe Paksu, Katarína Žilková</i> How Well Turkish and Slovak Preservice Elementary Teachers Comprehend Class Inclusion Related to Rectangle .....	225
<i>Yasemin Abali Ozturk, Mehmet Kaan Demir, Cavus Sahin</i> Preservice Teachers' Perceptions of Plagiarism: A Metaphor-Based Analysis .....	233
<i>Cevdet Yilmaz</i> Investigating Pre-service EFL Teachers' Perceptions of Teacher Qualities in the Context of Teacher Training .....	243
<i>Menekse Eskici</i> As An Activity Of The Teaching Process: Drawing Attention.....	251

<i>Arzu Deveci Topal, Esra Coban Budak, Aynur Kolburan Gecer</i> Effect of C Programming Language Instruction on Attitudes of the Students of the Biology Department towards Computer Programming .....	259
<i>Merve Kalayci, Sevgi Ozturk</i> Recreational Activity Habits of Undergraduate Students and Factors Affecting Their Habits: The Case of Kastamonu University Landscape Architecture Department Students .....	265
<i>Kadri Krasniqi</i> Factors that Affect the Learning Process .....	275
<i>Deniz Beste Cevik Kilic</i> An Analysis of Pre-Service Music Teachers' Self-Efficacy Perceptions Regarding Their Piano Playing Performance .....	281
<i>Abdullah Sahin, Yuksel Girgin, Onur Gurbuz, Mesut Kalin Sali</i> Assessment of Z-Book included in B2 Level of "Yedi Iklim Turkce Instruction Set" Used to Teach Turkish as a Foreign Language .....	287
<i>Canan Nakiboglu, Nuri Nakiboglu</i> Examination of 12th Grade Students' Cognitive Structures about Electrochemical Concepts through Word Association Test.....	293
<i>Canan Nakiboglu, Nuri Nakiboglu</i> Evaluation of "Chemistry and Electricity" Unit of 12th Grade Chemistry Textbook in terms of the Chemistry Triplet .....	301
<i>Ilhan Kulaca, Adil Adnan Ozturk</i> The Village Teacher Training Trials in Turkey, Mahmudiye Istructor Course and Mahmudiye Village Teacher Training School .....	307
<i>Nilgun Tosun, Gulsun Kurubacak</i> Learning Analytics In Open And Distance Education: Advantages And Disadvantages .....	315
<b>Educational Research</b>	
<i>Zeynep Gulsah Kani</i> Beyond Boundaries: A Critical Analysis of Paradigms in Educational Research .....	323
<i>Erkan Kiral,</i> The Relationship between Ethical Leadership and Job Satisfaction .....	333
<i>Hasan Arslan, Osman Ferda Beytekin, Meltem Kuscu</i> Evaluation of Effectiveness of Vitamin Teacher Portal .....	345
<i>Meltem Kuscu , Hasan Arslan</i> Mind Maps Related To Leadership Skills Of School Principals .....	353
<i>Ismail Colak, Nejat Ira, Aynur Gecer</i> Determination The Opinions Of The Secondary School Teachers Regarding The Use Of Mobile Technologies For Educational Purposes .....	363

<i>Perihan Ogdum, Sevil Ozcan</i> Examination Of The Information Literacy Levels Of Health Technicians Students:Aydin Health Services Vocational School Example .....	381
<i>Bilge Sevim Okuyan, Ahu Sezgin, Emrah Koksak Sezgin</i> Associate Degree Students' Self-Efficacy Beliefs about English Language Proficiency: The Department of Hotel, Restaurant and Catering Services at Davutlar Vocational School.....	389
<i>Gulden Ozturk Serter, Sukran Simsek, Yesim Yurdakul, Aynur Butun Ayhan</i> Examination of Parents' Problems in the Process of Inclusive Education .....	397
<i>Hasan Arslan, Muzaffer Ozdemir, Meltem Kuscu</i> Teachers' Perceptions Related to the Usability of Subliminal Messages in Education .....	405
<i>Mustafa Hilmi Bulut, Yeliz Kindaptepe, Baris Erdal, Turker Erol, Derya Kirac, Kubilay Yilmaz</i> Turkish University Students' Varied Musical Experiences Agreeableness Levels.....	415
<i>Elmira Rama</i> The All- Inclusive Process and Children With Severe Disabilities .....	427
<i>Ayse Ozturk Samur, Gozde Inal Kiziltepe, Esra Angin</i> A Research On Teachers' Liking Of Children And Children's Feelings About School, Opinions About Teacher And Perceptions About Their Academic Skills .....	435
<i>Gulsah Tasci, H. Tezer Asan</i> The Thesis Journey: "Doctoral Candidate's Perspectives" .....	443
<i>Osman Ferda Beytekin, Melih Unal</i> The Views of Foreign Language School Lecturers on Technological Leadership .....	451
<i>Ahu Sezgin, Emrah Koksak Sezgin</i> A Study on the Motives behind Vocational School Students' Preference of Culinary Arts Program and Their Opinions about the Program.....	461
<i>Ayse Ozge Kupeli, Mustafa Aydin Basar</i> Development Study of School Principals' Coaching Skills Scale .....	467
<i>Ozgun Uyanik Aktulun</i> Early Academic and Language Skills of Children from Urban and Rural Areas .....	479
<i>Alev Onder, Asude Balaban Dagal, Dilan Bayindir</i> Temperament and Resiliency as Predictor Factors of Preschoolers' School Readiness .....	487
<i>Ajka Aljilji</i> Quality, Knowledge Measure in the Performing of The Teaching of Natural Science and its Connection With Social Sciences .....	495
<i>Elif Yilmaz, Gulcin Guven, Turker Sezer</i> The Investigation of The Relationship Between Attachment Styles and Social Problem Solving Skills of Preschool Children .....	499

<i>Zafer Tural</i> Music Teacher Candidates in Piano Education: An Evaluation of The Causes of Their Success .....	507
<i>Canan Nakiboglu</i> Examination of High School Students' Thoughts about STEM before a STEM Study .....	515
<i>Rengin Zembat, Hilal Yilmaz</i> Examining The Relationship between Levels of Teaching Practices Preschool Teachers Use to Promote Children's Self-Regulated Learning and Their Self-Regulation Levels .....	521
<i>Ozgur Batur, Hasan Arslan</i> The Stakeholders' Perspectives for Universities' Social Responsibilities: The Case of Canakkale, Turkey.....	531
<i>Aysun Caliskan, Hasan Arslan</i> Quality Assurance Practices in Belgian Universities .....	543
<i>Yesim Yurdakul, Utku Beyazit, Sukran Simsek, Aynur Butun Ayhan</i> An Investigation of Parents' Habits of Reading Books to their Children and their Criteria for Selecting Children's Books .....	551





# The Internationalization Standards in Education and International Schools in Turkey

Ezgi Gol, Hasan Arslan

## 1. Introduction

In the 21<sup>st</sup> century that the internationalization came into prominence and international interaction became a need, different and innovative practices are needed in education as well as in all areas. When we see the education as a way to transfer information technologically, we can talk about the globalisation. But when we perceive the education as an information system being developed in the culture of a society and having cultural marks, we can talk about 'internationalization of the education' instead of globalization (Azizoglu,2012). Providing international education services is possible with well-organized administrators and educational institutions that know and practice their aims to comply with the international standards. In order to maintain internationalization in educational institutions, there are some implementations and the schools work and attempt to be accredited by the international accrediting agencies (Goksoy, 2014). CIS (The Council of International Schools) is well-known and respectable accrediting agency in the world and it is a membership community committed to high quality international education. In our country, there are some schools that are members or accredited by CIS. It shows that these schools meet obligations to give the best international education. Moreover, the number of schools that apply or have a right to be accredited is increasing continually so understanding the 'internationalization in education' becomes more important and necessary. For this reason, the aim of the study is examining the concept of 'internationalization' and its effects on education and evaluating the the international school accrediting system and accredited schools (CIS schools) in Turkey.

## 2. Literature Review

Internatilizatıon reflects a world system that was directed by the nation states (Scott, 1999; De Wit,2001). Internationalisation refers to an international collaboration and international quality for the benefit of everyone or assessing the quality in education. Internationalisation as a principle or a value, prevents the parochialism, even oppose the negative nationalism in some situations (Ozerdem ve Demirkiran, 2011).

According to Scott (1998: 124), globalization cannot be regarded simply as a higher form of internationalization. Instead of their relationship being seen as linear or cumulative, it may actually be dialectical. In a sensesense the new globalization may be the rival of the old internationalization. Scott (1999: 37) gives three main reasons why globalisation cannot be regarded as a higher form of internationalisation:

- internationalisation presupposes the existence of established nation states, where globalisation is either agnostic about, or positively hostile to, nation states;
- internationalisation is most strongly expressed through the 'high' worlds of diplomacy and culture; globalisation in the 'low'worlds capitalism; and of mass consumerism and global
- internationalisation, because of its dependence on the existing (and unequal) pattern of nation states tends to reproduce - even legitimize - hierarchy and hegemony; globalisation, in contrast, becausebecause it is not tied to the past, because it is a restless, even subversive, force can address new agendas (De Wit,2001).

In 1894, delegate from Russia, Prince Serge Wolkonsky described the international education in his speech at the International Educational Congresses of the Columbian Exposition in Chicago : "And so the union of these two words, "international" and "educational" - may it be blessed; may it resound in the hearts of all who will be present here; may it inspire the words and acts of the congress with great

ideas of universal impartiality; may it loudly proclaim that every one of us belongs, first, to humanity...” (Keller, 2011)

"International education" is a term used to describe the various types of educational and cultural relations among nations. While originally it applied merely to formal education, the concept has now broadened to include governmental cultural relations programs, the promotion of mutual understanding among nations, educational assistance to underdeveloped regions, cross-cultural education, and international communications (Carr, 1944; Scanlon, 1960). International education may be viewed as a means of changing the world by increasing international understanding through bringing together young people from many different countries (Cambridge & Thompson, 2004).

International education helps older people understand global interconnections and younger ones comprehend global differences. International education helps us create knowledge about one another. It takes us on an enriching, fascinating journey, each leg of which opens new doors, reveals more ports, and allows us to see visions and speak words that others can neither see nor understand. It creates new dimensions (Durtka et., 2002, 20-21). Moreover, for teachers with a sense of adventure, a career in international education can be a uniquely rewarding experience, both professionally and personally. It can allow you to broaden your horizon, become immersed in a different culture and environment, and perhaps learn or improve a foreign language. It offers the opportunity to make many new friends and forge life-lasting ties as you join a professional and highly engaged global community of educators (<http://www.cois.org>).

### **2.1. Internationalisation and Accreditation in Education**

All education is international. Learning and knowledge are connected to cultural systems that encompass the entire globe and beyond (Durtka et., 2002: 5). While the phrase ‘international education’ has been in existence for over a century (Walker, 2002), and the concept can be traced as far back as Socrates, via Montaigne (Walker, 1995; Wilkinson, 1998), it has yet to acquire a single, consistent meaning (Hayden and Thompson, 1995a, 1995b; Pasternak, 1998; Hayden et al., 2000; Cambridge and Thompson, 2004; James, 2005).

International education teaches about the lives and the natural and social contexts of people living in other countries and cultures and actively promotes immersion experiences in other cultures. International education explores interactions and connections among nations, especially the ways in which other peoples and cultures impact our daily lives. International education is an approach that creates awareness of political, economic, scientific and cultural interdependence that exists across national and cultural borders. International education acknowledges the complexity of the world's peoples, including their differences, similarities, conflicts, and connections (Durtka et., 2002:21).

International education is accepted as an important and strong alternative to the national education in the world (Fox, 1988). The children coming from many different cultures have education together in the same classes at schools both in and out of the official education systems in the world (Gordon, 1988). Educating students to become global citizens is a central claim to justify international education and study abroad (Davies & Pike, 2009; Schattle, 2009; Ramirez, 2013).

Leach (1969; Cambridge & Thompson, 2004) identifies internationalism with the maintenance of relations between different countries, and describes three approaches to its application in the field of education:

- unilateral internationalism, such as a country concerned chiefly with the education of its own personnel away from home in a different country;
- bilateral internationalism, such as exchange between and among students of two countries, chiefly at university level; and
- multilateral internationalism, requiring funding from at least three national sources, no one of them dominant.

Dolby and Rahman (2008; Keller, 2011) identified the following areas that fit under international education: comparative and international education, the internationalization of higher education,

international schools, international research on teaching and teacher education, internationalization of K-12 education, and globalization and education.

According to Wylie (2008), these are the rationale for international education;

- National curriculum not meeting the needs of schools in a changing educational milieu.
- Host country curriculum not meeting the needs of school constituents.
- Bureaucratic function, students gaining access to university and transnational networks.

The purpose of international education is not merely, if at all, to provide an education for internationally-mobile students in 'international schools' (Walker, 2002; James,2005). The aim of it is meeting the mental and emotional needs of the world children and remembering that mental and cultural mobility is the product of not only a person but also a thought firstly (Gruneberg,1976; Demirer,2002).The aims of international education are related to developing 'international understanding' for 'global citizenship', and the knowledge, attitudes and skills of 'international-mindedness' and 'world-mindedness' (Hayden and Thompson, 1995a, 1995b; Schwindt, 2003; IPC, 2005a; James, 2005).

The duty of international programs are helping the students to gain the abilities for achieving the aims different from the given by their own national programs and provide them to see the world from a wider perspective (Demirer, 2002). To provide internalization in education and give well-accepted international education services based on these standards, schools attempt to be accredited by the international accreditation agencies.

## 2.2. Accreditation

According to Middle States Commission on Higher Education (2006), accreditation is the means of self-regulation and peer review adopted by the educational community. The accreditation process is intended to strengthen and sustain the quality and integrity of education. It makes the worthy of public confidence and minimizes the scope of external control.

Accreditation takes place in registering the quality of education, diploma equivalence, practicing vital jobs, professional competence, authorisation and competence of professional training (Tunc, 2008). Accreditation that can be defined as assessing the educational institutions or programs according to certain standards is a type of self-organization and self-assessment as a process of quality control and maintain (Bakioglu ve Baltaci, 2010).

Educational accreditation is a type of quality assurance process under which services and operations of educational institutions or programs are evaluated by an external body to determine, if applicable standards are met. If standards are met, accredited status is granted by the agency. Accreditation has always been an essential part for helping to assure the balance between available resources and the provision of critical programs. Besides, accreditation provides students, organizations, governments, and professionals with the security of knowing that complaints about an institution, its curriculum, policies or staff will be reviewed, monitored, and forwarded to the proper offices for their review and necessary corrective action. This offers a strong sense of accountability to the international community, students, staff, and governments. The goal of accreditation is to ensure that education is provided by primary or secondary schools of education and they meet acceptable levels of quality. Accreditation of the schools could embark international level of education and learning facilities to their students (Rowley, Lujan, & Dolence, 1997; Furuzan,2012).

Accreditation has value for all members of the school community. Concerned professionals as well as parents naturally seek a quality education for children. Expatriate parents in particular face a strange environment which offers few guidelines on how best to select the most appropriate school for their child's needs. The importance of accreditation for expatriate families is particularly important, given the number of times they are likely to change countries and hence, schools. Selecting accredited schools helps ensure that a student's educational efforts and the quality of his/her academic studies will be recognized in their next country's school. It lets families know that their school is providing an education that meets internationally benchmarked standards ([http:// www. iics - k12. net](http://www.iics-k12.net)).

The process of accreditation aims (Sywelem & Witte, 2009; Furuzan,2012:649):

- (1) To assure the educational community, the general public, and other organizations and agencies that an accredited institution has demonstrated;
- (2) To promote deep institutional engagement with issues of educational effectiveness and student learning, to develop and share good practices in assessing, and to improve the teaching and learning process;
- (3) To develop and apply standards to review, and to improve educational quality and institutional performance;
- (4) To promote within institutions a culture of evidence where indicators of performance are regularly developed, and data are collected to inform institutional decision making, planning, and improvement;
- (5) To promote the active interchange of ideas among public and independent institutions that furthers the principles of improved institutional performance, educational effectiveness, and the process of peer review.

Accreditation provides accountability to the all stakeholders of the institutions and accurate information for parents. So, accrediting agency is very important at this point. ECIS - CIS (European-Council of International Schools) is the pioneer accrediting agency that provides opportunity of giving well-accepted international education and international recognition to the schools from all over the world.

### 2.2.1. ECIS / CIS

ECIS (European Council of International Schools) is the biggest nonprofit membership community of international schools that was founded in 1965. ECIS (European Council of International Schools) has been served as 'Council of International Schools (CIS)' since 1 July 2003. In order not to have a difficulty because of this change, time was given to accredited schools for adaptation. CIS (The Council of International Schools) is well-known and respectable accrediting agency in the world and it is a membership community committed to high quality international education (<http://www.cois.org>).

As a global non-profit membership organisation, CIS provides services to primary and secondary schools, higher education institutions and individuals that share these ideals:

- a desire to provide students with the knowledge, skills and abilities to pursue their lives as global citizens; and
- a commitment to high quality international education (<http://www.cois.org>).

To achieve these goals, the members must infuse their programmes and offerings with international and intercultural perspective so that students can move forward with the attitudes and understanding that will provide them with a solid base wherever their studies or work may take them. Primary and secondary school members must further commit to undertaking an ongoing external quality assurance process to enhance student learning. The CIS community includes 729 schools and 556 colleges and universities representing 112 countries. According to CIS, there are some steps in the process of accreditation:

- Application and Preparing Preliminary Information Report -140 questions
- Prior Review Visit and Prior Report
- Self-Assessment Process and Reporting (The whole school members join this process)
- Team visit and report
- Evaluating the report by ECIS Accreditation Board
- Accreditation process / giving time/ taking out off the process
- One year report
- Five year report and visit
- Renewal of all the operations in the 10th year (<http://www.cois.org>).

### 2.2.3. Standards of CIS (Council of International Schools) and Accreditation

The CIS (Council of International School) is a non-profit membership organization that provides services to elementary and secondary schools and higher education institutions around the world that have the following aspects in common. The school that has been accredited by the Council of International Schools is conforming these standards:

- a. Philosophy and Aims
- b. Organisation and Management
- c. Faculty
- d. Kindergarden and Prep Classes Curriculum
- e. Primary Classes Curriculum
- f. Elementary Classes Curriculum
- g. High School Curriculum
- h. Private Education
- i. Guidance Services
- j. Health Services and Safety
- k. Student Services
- l. Student Life
- m. Library / Media Center
- n. Physical Opportunities of The School
- o. Finance and Management of Finance
- p. Assessment and Evaluation of Students (<http://www.cois.org>).

Keller (2011) described the advantages and disadvantages of CIS Standards. The advantages are large influence and intergrated into authorization process and the disadvantages are standards not part of separate process, focused exclusively on international education, may be missing some components, less focused on community perceptions.

CIS accreditation standards and indicators applied at some private schools in our country provides with a chance to an education understanding integrated national values of each country and international ones. Also, increasing the number of schools that applied for and accredited by CIS in our country is beneficial for the internationalisation of education to be widespread.

### 2.2.4. Characteristics of An Accredited School

The final award of Accredited Status from CIS demonstrates that a school is aligned with the demanding CIS Standards for Accreditation. It shows that the school has achieved high standards of professional performance in international education and has a commitment to continuous improvement. In particular, the award of accreditation shows that:

- The school is devoted to its Mission and Vision for Students, as expressed in its Guiding Statements. The school also adheres consistently to the CIS Code of Ethics for Member Schools.
- The school cares enough to seek validation from a recognised accreditation authority for the work it does for its students.
- The schools focuses on the quality of teaching and the progress students make, their standards of achievement (in the broadest sense) as well as the students' well-being.
- The school knows itself. It has thought deeply about the services it offers to students, family and community.
- The school is student-orientated. Its philosophy of education is suitable for the students on roll and encompasses the development of the whole individual.
- The school keeps its promises. It promises only what it can deliver.
- The school accepts objective assessment. It is prepared to open its doors periodically to regular evaluation by its own school community and by outside experienced practitioners.
- The school is constantly seeking to improve its performance in all areas in order to ensure it attains the desired learning outcomes for its students.

- The school plans strategically for the future. As part of the on-going nature of the evaluation process, accredited schools are continually planning future developments (<http://www.cois.org>).

An accredited institution is expected to possess or demonstrate the following attributes or activities (Middle States Commission, 2006) :

- a chief executive whose primary responsibility is to lead the institution toward the achievement of its goals and with responsibility for administration of the institution;
- a chief executive with the combination of academic background, professional training, and/or other qualities appropriate to an institution of higher education and the institution's mission;
- administrative leaders with appropriate skills, degrees and training to carry out their responsibilities and functions;
- qualified staffing appropriate to the goals, type, size, and complexity of the institution;
- adequate information and decision-making systems to support the work of administrative leaders;
- clear documentation of the lines of organization and authority; and
- periodic assessment of the effectiveness of administrative structures and services

### 2.3. International Schools

Looking at the teenager education from a global perspective is not a new situation. In 1580 Montaigne wrote that 'this great world is the mirror in which we must look at ourselves to recognize ourselves from the proper angle.' (Gordon, 1988).

The general aim of the international education; meeting all the people's needs, providing information, skills and insights by accepting the similarities as well as the differences among the individuals (Demir, 2002). Because the mobility of people in the world increases, the need for education of children growing and living in different countries increases. Thus, the international school market is generated and developed day by day.

Due to the increase at the number of international students and diversity of intercultural education needs, education services need to be international. International education is approved as an important and strong alternative to the national education gradually in the world (Fox, 1988). Today, international schools are spreading all over the world, offering a multicultural K-12 education, mainly for the children of expatriates of their host country. According to Murphy (2003), the foundation of these schools lay on the desire for an education across the borders to help the adults of tomorrow learn to live peacefully. "... the expansion of world markets brought a sharp increase in foreign travel for globalization, mostly Western ... this fact, and the desire of the non-English-speaking world to learn enough English to share in the wealth created in this new economic order ..." (Murphy, 2003: 48) sounds like a stronger reason behind the existence of international schools than the former (Corlu, 2002: 7).

Formal education knowledge can be considered to be realized through three message systems: curriculum, pedagogy, and evaluation. Curriculum defines what counts as a valid knowledge, pedagogy defines what counts as a valid transmission of knowledge, and evaluation defines what counts as a valid realization of this knowledge... (Bernstein, 1975: 85) In international schools as elsewhere these message systems are associated with mechanisms of learning and control exercised through the work of teachers and their employment of information and communication technologies. By categorising the practice of international schools as curriculum, pedagogy, assessment, teachers work and ICT it is possible to deconstruct the practical activities of international schools (Wylie, 2008).

International schools are often the ideal environments for improving your own educational practices and developing new skills in collaboration with your peers. Rich and varied professional development programmes are common benefits of working at an international school as are the availability of modern teaching resources and technology. An overseas teaching opportunity can allow you to engage with motivated students with high expectations and really have an impact on their development as global citizens. International schools frequently offer a comprehensive salary and benefits package that may provide higher remuneration than that offered by national or state schools

(<http://www.cois.org>) . There are many opportunities to be involved in international education. Institutions are often involved in providing programs to enhance competencies for internationally educated professionals, integrating international students into programs, and developing courses and programs for delivery in host countries (Bolan and Bolan, 2006; Dragoescu Urlica Alina-Andreea, 2018).

#### **2.4. International Schools In Turkey and In The World**

The demand of international education and its variety increased in our country in parallel with increasing international studies in education around the world, but the governance was incapable of meeting this demand. To solve this problem, the number of private schools in this area must be increased.

Private schools in Turkey are classified as: Private Turkish Schools, Private Foreign Schools, Private International Educational Institutions and Private Minority Schools. Private Turkish schools are the schools registered to National Education Ministry and give education in a second language with Turkish. Private Foreign Schools are the schools opened by foreigners and their existences were recognized by the mutual letters depend on Treaty of Lausanne. They were founded by French, German, Italian, Australian and Americans during the Ottoman Empire and also Turkish students could take education ([www.earged.meb.gov.tr](http://www.earged.meb.gov.tr)).

International Schools are the schools founded mostly for the foreign children in the country, the children whose parents have continuous travel obligation, the children of these schools' instructors, ambassadors' children and the children of the parents worked at international organizations. Moreover these schools are preferred by the students that want to improve their foreign languages. International schools are mostly private but there are public international schools. A bridge country that straddles Europe and Asia, Turkey has a lot of international schools that address the needs of both expatriate and Turkish families. Our country is a home to international schools that most of them typically follow globally standardized curriculums of the International Baccalaureate Office (IBO) or the Council of International Schools (CIS). They provide expatriate families an opportunity of educating their children in a way that will prepare them for life in their own country, and they allow native students the chance to get an international education that will prepare them for a global world.

In our country, there are some schools that are members or accredited by CIS. It shows that these schools meet obligations to give the best international education. Moreover, the number of schools that apply or have a right to be accredited is increasing continually so understanding the 'internationalization in education' become more important and necessary. In Turkey there are twenty seven member schools of Council of International Schools and nineteen of them are accredited. These schools are located in big cities such as Istanbul, Ankara, Izmir, Bursa and Tarsus. In addition to this, the CIS community includes 733 schools and 592 colleges and universities representing 112 countries all over the world. The main offices of the community are in Netherlands and America.

The award of CIS Accreditation demonstrates a school's commitment to high quality international education to the school community as well as to the outside world: prospective families, educational leaders and teachers as well as universities, embassies, other government departments, and globally-minded companies and organizations. Concerned professionals as well as parents naturally seek a quality education for children. Expatriate parents in particular face an unfamiliar environment which offers few guidelines on how best to select the most appropriate school for their child's needs. The fact that a school holds CIS Accreditation can be very important in parents' choice of school (<http://www.cois.org>).

### **3. Conclusion**

International education is a contested field of educational practice involving the reconciliation of economic, political and cultural/ideological dilemmas. One current identifies international education with international development aid and the transfer of expertise between national systems of education. Another identifies international education with the development of international attitudes, international awareness, international-mindedness and international understanding (Cambridge &



Thompson, 2004). Recently, the international schools have increased noticeably in terms of both number and variety. The rapid numerical increase of schools described themselves as international creates a need for a suitable description for the international education. For countries, educational aims must be giving a qualified education for their citizens and determining universal rules and standards to compete with the other countries. The institutions and organizations define the quality standards for the education systems of developed countries can be organized as public, private, volunteer, paid and compulsory..etc. In our country, educational institutions must take into consideration the universal quality standards and work through these, also reflect these standards to their strategic plans and be evaluated based on this standardization in order to improve the quality in education. Moreover, it is important to provide the standardisation in the education levels before the higher education and develop an international understanding in order to carry on internationalisation activities effectively in our country.

#### 4. References

- Azizoglu, O.H. (2012). Egitimin Uluslararasılaşması ya da Küresellesmesi. (<http://www.timeturk.com/tr/makale/orhan-hikmet-azizoglu/egitimin-uluslararasilasmasi-ya-da-kuresellesmesi.html>).
- Bakioglu, A. ve Baltaci, R. (2010). Akreditasyon: Egitimde Kalite. Ankara:Nobel Yayın Dağıtım.
- Bolan, C. M. ve Bolan, S. J. (2006). A Model for Developing International Education: Bringing It All Together. *College Quarterly*,9 (4).
- Cambridge, J. & Thompson, J. (2004). *Internationalism and globalization as contexts for international education*. Compare: Journal of Comparative and International Education,34 (2), 161-175.
- Corlu, M.S. (2006).An Ethnographic Research: The Cultural Portraits of Middle School Mathematics Classrooms in An International School. *Master Thesis*.Bogazici University, Istanbul.
- De Wit, J. W. M. (2001). Internationalisation of Higher Education in the United States of America and Europe Amsterdam: in eigen beheer . UvA-DARE (Digital Academic Repository)
- Demirer, V. (2002). Uluslararası Bakalorya (IB) Programı Uygulayan Özel Okullarda Çalışan Öğretmenlerin Bu Programa Karşı Olan Tutumlarının İncelemesine Yansımaları. *Yüksek Lisans Tezi*. İstanbul Üniversitesi Sosyal Bilimler Enstitüsü, İstanbul.
- Dragoescu Urlică Alina-Andreea. (2018). The ecology of language as an optimal learning model. In *Quaestus Multidisciplinary Research Journal*.
- Durtka,S.,Dye,A.,Freund,J.,Harris,J.,Kline,J.,LeBreck,C.,Reimbold,R., Tabachnick,R.,Tantala,R. & Wagler,M,(2002).Planning Curriculum in International Education. *Bulletin*,3033, Wisconsin State Dept. of Public Instruction, Madison. <http://www.dpi.state.wi.us/pubsales>.
- Furuzan, V.G. (2012). Accreditation Policies of Turkey in Primary and Secondary Education. *US-China Education Review*, 7, 647-656.
- Goksoy, S. (2014).Eğitim Sistemlerinde Kalite Standartları ve Kalite Standart Alanları. *21. Yüzyılda Eğitim ve Toplum*, 3 (7), 85-99.
- James, K. (2005). International education: The concept, and its relationship to intercultural education. Sage Publications, 4 (3), 313–332. <http://jri.sagepub.com/cgi/content/abstract/4/3/313>.
- Keller, D. (2011).Toward a system of evaluating a school's international education program. Presentation, Inspiring Education ,27-30 October, The Hague
- Middle States Commission on Higher Education (MSC). (2006). *Characteristics of excellence in higher education* (12th ed.). Philadelphia, P. A.: Middle States Commission on Higher Education Publications.
- Ozerdem, F. ve Demirkıran, S. (2011). Uluslararasılaşma ve Türkiye'deki Üniversitelerin Uluslararasılaşma Anlayışları. Uluslararası Yükseköğretim Kongresi: Yeni Yönelişler ve Sorunlar.1 (VII), 682-689.

## The Internationalization Standards

- Ramirez, G. B. (2013). Learning Abroad or Just Going Abroad? International Education In Opposite Sides of the Border. *The Qualitative Report*, 18, Article 62, 1-11  
<http://www.nova.edu/ssss/QR/QR18/ramirez62.pdf>
- Scanlon, D.G. (1960). *International Education: A Documentary History*. New York: Bureau of Publications Teachers College.
- Tunc, M. (2008). *Turkiye Orta Ogretiminde Egitim Akreditasyonu Bir Model Onerisi*.  
[http://www.mutlutunc.com/files/meb\\_sunus.pdf](http://www.mutlutunc.com/files/meb_sunus.pdf) (Erisim tarihi: 10.12.2014).
- Wylie, M. (2008). Internationalizing Curriculum: Framing Theory and Practice in International Schools.  
*Journal of Research in International Education*, 7:,5-19.
- [www.cois.org](http://www.cois.org)  
[www.earged.meb.gov.tr](http://www.earged.meb.gov.tr)  
[www.ecis.org](http://www.ecis.org)



# Assessment of the 6-11 aged Syrian Refugee Children's Educational Needs: A Multidimensional Analysis

Ruken Akar Vural, Nermin Karabacak, Mehmet Kucuk, Senol Sezer, Cigdem Celik

## 1. Introduction

Out of more than one million Syrian school-age children in Turkey, only 612 thousands of them have been enrolled in 2017-2018 school year. As well as there are quite a lot number of school-age immigrant children, it is a known fact that the ones accessing to education or in exact opposite have confront serious troubles. Temporary Learning Centers (TLC) to which Syrian children continue is the training centers including primary and secondary education that give Arabic education to the school-age Syrian children and youths adhered to Syrian Education Programme (MEB, 2014). There are total 425 'TLC' in 21 cities across Turkey. Of these 36 operate in camps and 389 of them are in service on the outside of the camp. There is also the Turkish Language Education that is carried out at Temporary Learning Centers, however it is underlined that the Turkish lessons given to the Syrian children both at temporary learning centers and public schools, curriculum (objectives, standarts, materials, strategy, method and techniques) and in terms of teacher qualifications are by no means continued qualitatively. On the other hand, the inadequacy of the teachers assigned by MEB in terms of teaching Turkish to foreigners deepens this problem (Coskun and Emin, 2016)

The refugee children going to public school and continuing their education in Turkish have problems with the learning and adaptation. Another problem is the participation of the refugee children at the first and second grade class levels seriously decreases in the forthcoming years. Apart from the common problems among the ones that have education, the number of children leaving the education life after coming to Turkey is also exceedingly high. The number of Syrian children being not schooling is more than 400 thousands only by the end of the year 2017. Given of the ones that are also in compulsory school-age in the previous years and the ones that are not reflected on the statistics, it can be said that there are at least 700-800 thousands of children affected by this situation ranked as 'the lost generations'. As well as there are a number of studies related to the immigrant students that have problems or comments made on them (Boru and Boyaci, 2016; Duruel, 2016, Ozer, Komsuoglu and Atesok, 2016; Polat, 2012; Saglam and Kanbur, 2017; Uzun and Butun, 2016) there are limited studies focused on especially the problems the teachers confront and their vocational development needs (Balkar, Sahin & Isikli-Babahan, 2016; Maya, 2016; Onder, 2017). The aim of this study performed by taking into consideration the problems confronted in the education of refugee children is to determine the education requirements of the Syrian refugee children that go to primary school in Rize and Aydin cities. The other purpose of this study is to analyze what sort of problems that refugee children confront and what they need based upon the comments made by the teachers that work at a public school titled as 'adaptation school' in Izmir city. In accordance with this purpose, the following questions need to be answered:

1. What are the socio-demographic features of school-age refugee children?
2. What is the source of learning Turkish of school-age refugee children?
3. What things do the school-age refugee children need to do well in school?
4. How do the teachers perceive the processes of gaining experience in the education of refugee children?
5. How do the teachers evaluate the pre-service and in-service training that they receive in terms of getting proficiency of teaching for the refugee children?
6. What kind of problems do the teachers confront with the refugee children and their parents?

## 2. Method

### *Research Model*

This study is in the mixed research design. For this purpose, 5 public primary schools in which the children of low socio-economical status families have education and the Syrian refugee children attend in Rize have been included in the study. Besides, one public school in Izmir city defined as the adaptation school which the children of low socio-economical status families and the Syrian refugee children go to; has been addressed as 'single case study' and the data have been gathered from this primary school through the instrument of both inventory and the semi-structured interview forms.

### *Sample*

There are two working groups in the study. The first group is comprised of 130 Syrian refugee students that go to 6 primary schools placed in the cities of Izmir and Rize. The data from students have been collected from one in Izmir city and 5 separate primary schools in Rize city. The second working group is composed by the refugee primary school students attending a state school defined as the adaptation school in which the children of low socio-economical status families have education and 8 primary school teachers provided that the two of them are from each class level. Both students and the teachers have been assigned on a volunteer basis. Teachers have been specified according to the typical case sample technique out of purposeful samplings. The study group composed of the primary school teachers graduated from the faculty of education that have the Syrian refugee student in their classes and have not had any special training about this subject before.

**Table 1.** *The demographic features of teachers (N=8)*

Code	Job Seniority	Class
T1	19	4
T2	14	3
T3	21	3
T4	17	2
T5	20	4
T6	18	1
T7	15	2
T8	11	1

### *Data Collection Tools*

Two data collection tools have been used in the study. 'The Inventory of Determining the Educational Requirements of the Syrian Refugee Children in Primary School Age' (Akar-Vural, Kucuk and Karabacak, 2018). Inventory has been comprised of the demographic data belonging to students and also including the open-ended 50 questions. The semi-structured interview forms prepared by receiving expert opinions have been used by the researchers in the face to face meetings with the class teachers from different teaching levels that have the Syrian refugee children in their classes.

### *Data Analysis*

The data obtained from the inventories have been analysed by SPSS, their frequency and percentage values have also been calculated. The collected data based on the face to face meetings through the instrument of the semi-structured interview forms have been analysed by content and descriptive analysis techniques. In the process of descriptive analysis, the summarisation and the interpretation are in question according to the themes revealed by research or interview questions. In this process, first the data are defined in detail and after that these analysed definitions are clarified by using direct quotation obtained from interview data. Content analysis generally can be expressed as the 'search for meaning' in data (Hatch, 2002). This process contents the export of the data, the combination of what the participants say, what the researcher sees and how he/she reads and the interpretation. Data analysis is a complicated process that includes back and forth step in between hard data pieces and

abstract concepts, induction and deduction (Merriam, 2009). In the beginning of the data analysis, the interviews recorded by the tape recorder have been computerized. The recorded interviews have been coded by using open codes. On the basis of open codes, axial (typologic) codes were registered, and through the categories and themes were determined. Inductive method were taken as a basis of combining the themes. The process of the data analysis based on inductive takes a form as deductive in the end of the process analysis (Merriam, 2009). The themes in this process were controlled in terms of whether they support all data. While determining the themes, primarily the descriptive analysis was used with the relation to the improved open-ended questions based on the literature, and the themes were identified. In addition, the descriptive analysis and content analysis was also conducted in this process, thus the potential new themes were identified. The semi-structured interview form comprised of two parts introduction and transition questions, 9 essential and 3 exploratory questions was used during the interviews.

### 3. Findings

The demographic features of the school-age refugee children are given in Table 2.

**Table 2.** *The demographic features of the refugee children (N=130)*

Variance		1	2	3	4	5	Total
		1. Class	2. Class	3. Class	4. Class		-
Class Level	<i>f</i>	52	59	14	5		130
	(%)	40	45.4	10.8	3.8		100
		Female	Male				-
Gender	<i>f</i>	71	59				130
	(%)	54.6	45.4				100
		Yes	No				-
The situation of losing one's relative in war	<i>f</i>	25	105				130
	(%)	19.2	80.8				100
		2	3	4	5	6 and more	-
Number of siblings	<i>f</i>	28	22	25	28	27	130
	(%)	21.6	16.9	19.2	21.5	20.8	100

In table 2, it is seen that the number of the first grade children (n=52, 40%) and the second grades (n=59, 45.4%) are high, but the third and fourth grades are quite low. From the viewpoint on the gender variable, it is seen that the number of female students (n=71, 54.6%) are relatively higher than the male students (n=59, 45.4%). Among the refugee children with forced migration after the war, the number of the children who lost their relatives during the war is (n=25, 19.2%) and the ones that express no loss is (n=105, 80.8%). These results can be considered as an important data in terms of evaluating the psycho-social improvement of the refugee children healthfully. Besides, it is seen that in over half of the refugee children have five or more siblings. The frequency and percentages are given in Table 3, regarding the working condition and the educational background of the refugee children's fathers and mothers with the level of their income status.

**Table 3.** Parents education-working status and household income (N=130)

Variance		1	2	3	4	5	6	Total
		Illiterate	Literate	Primary School	Secondary School	High School	University	-
Education Level (Mother)	<i>f</i>	78	14	13	16	5	4	130
	%	60.0	10.8	10.0	12.3	3.8	3.1	100
Education Level (Father)	<i>f</i>	73	15	9	15	6	12	130
	%	56.3	11.5	6.9	11.5	4.6	9.2	100
		Working	Not working					-
Working Condition (Mother)	<i>f</i>	10	120					130
	%	7.7	92.3					100
Working Condition (Father)	<i>f</i>	107	23					130
	%	82.3	17.7					100
		0-1000	1001-2000					-
Household Income (TL)	<i>f</i>	62	68					130
	%	47.7	52.3					100

In Table 3, it is seen that the majority of the mothers (n=78, 60%) and the fathers (n=73, 56.2%) of the refugee children in sampling group are not literate in their language. Almost all of the mothers of the refugee children (n=120, 92.3%) do not work at any job. The number of the children both their mothers and fathers in no service is 23. Considering the household income of the children in the sampling group, it is seen that the income of almost half of them is under 1000 TL.

**Table 4.** Turkish language proficiency of the parents and the source of learning language of the child (N=130)

Variance		1	2	3	Total
		None	Poor	Average	-
Turkish language proficiency of the mother	<i>f</i>	116	12	2	130
	(%)	89.3	9.2	1.5	100
Turkish language proficiency of the father	<i>f</i>	91	33	6	130
	(%)	70.0	25.4	4.6	100
		School	Street		-
The source of the childs' learning Turkish	<i>f</i>	113	17		130
	(%)	86.9	13.1		100

In Table 4, it points out that the distribution of the Turkish language proficiency level of the mothers expressed as 'none' (n=116, 89.2%) and 'poor' (n=12, 9.2%) are high. The distribution of the Turkish language proficiency level of the fathers expressed as 'none' (n=91, 70%) and 'poor' (n=33, 25.4%) are quite high as well. It is seen that the source of learning Turkish of the majority of refugee students reflected as 'school' (n=113, 86.9%), and the number of the ones that learn on the street (n=17, 13.1%) are very low.

The third question of the study is 'what things do the school-age refugee children need to do well in school?' This question has been answered by 88 students.

The frequency and percentage values of the answers are given in table 5.

**Table 5.** The frequency and percentage values of the requirements of the students (N=88)

Requirements	f	%
Learning Turkish better	24	27.3
Private course backing	15	17.1
Studying hard	15	17.1
School supplies	13	14.9
My friends playing with me	6	6.8
Becoming a homeowner	4	4.5
Being with my mum	3	3.4
Having money	2	2.3
Loved by my teacher	1	1.1
Having a ball	1	1.1
Being loved	1	1.1
Being loved by my friends	1	1.1
Gym and pool in the school	1	1.1
Arabic lessons	1	1.1
Total	88	100

In Table 5, the answers show that refugee children are in the more needs such as learning Turkish better in the school (f=24, 27.3%), private course backing (f=15, 17.1%), studying hard (f=15, 17.1%), school supplies (f=13, 14.9%). Other answers are given like my friends playing with me (f=6, 6.8%), becoming a homeowner, (f=4, 4.5%), being with the mother (f=3, 3.4%), having money (f=2, 2.3%). In addition, the refugee children have expressed their needs about the affection of their teachers (f=1, 1.1%), having a ball (f=1, 1.1%), being loved (f=1, 1.1%), the love of their friends (f=1, 1.1%), gym and pool in the school (f=1, 1.1%), and Arabic lessons (f=1, 1.1%).

The second working group in the study is comprised of 8 class teachers working in a school that gives education the low socio-economical status families within the scope of 2.200 students in Izmir. The Syrian students also take part in those teachers' classes for average two years around. The school has combined a project team and performed a study for the adaptation of those children. Within the body of this project; literacy courses, children festivals, collaboration with the institutions that supply financial support for the children are arranged.

Another question of the research is 'How do the teachers perceive the processes of gaining experience in the education of refugee children?' All of the teachers (n=8) have opined that they have not had such experience before meeting a refugee children in their classes and firstly trying to understand them, showing an empathy, and approaching equally in comparison with other students. All teachers have emphasised that the difficulty in language is the major obstacle for them to learn. Two of the teachers that have more than one refugee child in their classes have stated that they hamper those students to communicate with each other, encouraging them to spend their time with others instead and in this way they support their learning Turkish. The comments made by some teachers in this regard as follow:

*'I tried to adapt myself to the situation. I approached them how I behaved the others.'* [T5]

*'Obviously, before I met these students I didn't have any knowledge of what it can be done or what kind of education it can be given. We came accross with them out of the blue'* [T6]

*'I didn't panic as how we communicated. I didn't do anything different for them'* [T3]

*'No, I didn't know that. It simply popped up out of the blue'* [T2]

There are stunning examples in this part regarding the practises of the teachers in the process of adaptation:



*'If we need to play we do this together. I don't want them to leave for another game. I arrange the mixed groups so that their Turkish improves in the interaction with other children.'* [T3]

*'I try to understand them. I never separate them from the others. How we can separate them, since they are children, too.'* [T7]

*'I enable these children to join every activities so that they can socialise with their friends. I don't leave them aside. I have a student that has come in previous years. He/she sometimes interprets. I felt that these children had lack of self-confidence. I tried overcoming this by giving them responsibilities. As an example, I gave a mission about distributing storybooks to one Syrian and Turkish student.'* [T8]

*'I tried hard to harmonise them with their friends by behaving unbiased. Other children already accept them easily. There is a childish language between them. And this language is common language.'* [T1]

*'During teamwork, I distribute the refugee children in groups so that they make friends and keep them at arm's length. Sometimes I hear from my students saying that they are Syrians, not clean and they run away from their countries leaving behind. Unfortunately they are affected by their families. I don't allow this. I try to avert this as much as I can.'* [T2]

*'I put on Turkish music. I sometimes put on Arabic music so that they don't feel themselves different completely. Besides, I don't let them much to speak Arabic between each other. The intention is for them to learn Turkish.'* [T2]

The other question of the study is 'How do the teachers evaluate the pre-service and in-service training that they receive in terms of getting proficiency of teaching for the refugee children?' All teachers have declared that they haven't had any course regarding the refugee children in the department of student training programme of the Faculties of Education. The same whole working group has also stated that these students want to learn their language and cultures which may be advantageous for them but learning the language spoken in the country where they immigrate is more important. Half of the teachers have asserted that teaching Arabic and Arab culture is not enough for the refugees in the changing world, for this reason it is not right to focus on one refugee group. In the case of one lesson given at the university, they have expressed that the content of this lesson should be composed of the titles such as different cultures, multiculturalism, cultural adaptation, the class adaptation and the education in different languages. Some of the teacher opinions about this topic are as follow:

*'I didn't have the pre-service education related to the refugee children. I really don't know whether or not I wanted to have this. Today these children come from Syria. But what would we do if they came from Greece tomorrow? Those children and their families must learn Turkish.'* [T1]

*'I didn't have the pre-service education related to the refugee children. I never thought this but it could've been explained with different exercises oriented for them regarding how we should behave. It could have been informed about what sort of things we should take care in terms of the adaptation of these children to the classes.'* [T4]

*'No, I didn't have this. The biggest problem is language. Should I have learned Arabic, Bulgarian or Georgian? I think NO. But a lesson with a title as 'How can we adapt foreign students to our system?' could be beneficial.'* [T5]

*'No, I didn't have this. We are now talking for the Syrians. There can also be the refugee children coming from another country. For example, it can be Greece. Their language is different. Their culture is different. Their civilisation is different. I wish I had a course especially on the education and training of different language and culture.'* [T6]

*'No, I didn't have this. I believe that these children and especially their families are in need of learning Turkish. However, I wish I had a knowledge of how a foreign child could adapt him/herself to the class and do well with other children in terms of communication and collaboration.'* [T7]

In this section, teacher opinions regarding in-service training they have aimed at refugee children are given. The teachers have expressed that they had a two-week education. The teachers have stated that the content of the education had basic concepts such as immigration, refugee, forced

## Assessment of the 6-11 aged Syrian Refugee Children's Educational Needs

migration etc... The teachers have pointed out that throughout the course they have been informed by the rights the refugee children have, and also they have stated that the course focuses on the topic that the education is mainly about showing an empathy and needs to set at work by accepting them unconditionally. They have expressed that the process of education is planned on the basis of game and animation; therefore it is entertaining. The teachers have implied that they need an education including how they communicate with the Syrian children and how they support to adapt them to the classes and how they get them to comprehend the content of the school program, and for this reason the present education program doesn't meet the needs. Some of the comments by teachers as following:

*'I think it wasn't quiet enough. Personally I can say that; we already love these children. We accepted them. It wasn't an education that solved the problems I had.'* [T8]

*'It wasn't enough. It didn't give any place to the subject about how we had to work with these children, how we actualized the learning. These are just children, we should understand. Let's educate. Common topics were underlined like embracing them. There wasn't any subject that we had regarding how we helped these children.'* [T3]

*'It wasn't beneficial. It wasn't for the problems that we confronted in the classroom environment to make it easy. It was just for an inculcation of why we had to accept these children.'* [T4]

*'In fact, there wasn't really anything in the content of in-service training. It's no use to bemoan. These people are here. Let's we relax by accepting them in no time and do our thing. The whole context included the words that supported these expressions. Obviously, the content wasn't in the shape of giving a satisfactory answer to the question as how we could do better for the education of this children.'* [T7]

In this section, the teachers' comments are given about the problems they have with the refugee children and their parents. Almost all of the teachers (n=7) have pointed out that the biggest troubles are that the family and the child don't know Turkish. They have expressed that acquiring language proficiency has key importance. The teachers suggest collecting the opinions of different sections in a pool about this topic officially and developing a permanent policy. They have expressed that in-service training should be planned and continued on the basis of providing teachers the knowledge and skill about the classroom communication with the refugee children and the curriculum. Furthermore, the teachers have offered that the students in the status of the refugee should firstly be included in the adaptation programme and then sent them to schools. Almost all of the teachers (n=7) have articulated that the majority of the parents hasn't got enough attention about their children's education, having language problem, making no contact with them and not exerting themselves to learn language. They have underlined that this situation hampers the child to develop Turkish language skills. The teachers' comments are follow:

*'I can't contact with the parents. Because they don't know Turkish. My Syrian parent came to me. I told him/her that you should learn Turkish, help your child at home and support him/her. H/she complained about his/her troubles. They had little children. They couldn't come. We are in this kind of 'Catch 22' situation.'* [T8]

*'We can never contact with each other if there isn't any translator. There are courses both in school and the public education center but the participation is low. I think more participation is needed'* [T7]

*'We contact through interpreter. Are you going to back your country when the war is ended? They say: "NO" Then I say that you learn our language a little. But unfortunately, they are not in a struggle for this. They don't have any effort to communicate after all.'* [T1]

*'No, I can't communicate with them. Even though I call them, it is difficult for them to come. When they come, we get help from the children for translation. There are enough arrangements that are provided for them to participate the activities in our school but they do not come. They need to learn some Turkish to communicate.'* [T3]

#### 4. Discussion and Conclusion

The civil war in Syria has displaced about 6.5 million Syrians. In this period, about 3 million Syrian immigrants have migrated to Turkey. The 50% percent of the population that has migrated is under 19 years old. Among the immigrants, one million of them are in school age. Turkey hasn't found a chance to develop an effective policy about the subjects such as education, health, sheltering and employment for this fast developing mass immigration and especially there has occurred serious troubles in education sector. The school age child and youths have education in schools and temporary education centers (Dallal, 2016). There are Syrian teachers that give education in temporary education centers, but there occur problems with the teaching certificates of these teachers and their harmonization (Alhaj, 2017).

When the findings are examined, it is seen that the primary school-age refugee children composing the working group have insufficient language skills, speaking Arabic at home and very weak Turkish skills that their mothers and fathers have. The results show that the children learn Turkish in school but it is not enough in terms of academic success. The findings reveal that the Syrian refugee children's family have low housing income, high number of siblings and they are in need the social and emotional support. Because the teachers have an important cognitive property in terms of learning language skills in education, their statements about the eloquence and rhetoric insufficiencies of refugee children in Turkish causing these children to have academic failure can be evaluated as remarkable finding (Erdem, 2017). It is seen that the teachers do not have any pre-service training about the education of the refugee children and the improvement of their adaptation skills to school. The teachers have expressed that they have two-week in service training but this education focuses on only unconditional acceptance and empathy, the importance of academic content, the education requirements about providing language and reading skills are still in process. The teachers have underscored that the children come to school by definitely learning Turkish within the context of prep school. Additionally, the teachers have declared that the refugee mothers and fathers don't have enough interest in learning 'reading and writing' in Turkish or helping their children with this and these cause a problem in terms of the cooperation in between family and school. In the research study conducted by Coskun and Emin (2016) about the problems that are confronted in the process of the education and the adaptation of the Syrian children, learning Turkish is placed as the most important problem among the findings. Given that the great majority of the Syrian children learn Turkish in school, the necessary support about the continuation of school should be suggested. On the other hand, relatively the low number of the students that attend the third and fourth classes give rise to think that they work income generating jobs and for this reason they don't come to school. In the similar study conducted by Coskun and Emin (2016), it is remarked that the number of schooling rate reduces as the levels progressed, showing that the schooling is mostly in the first grade level and least in the 11<sup>th</sup> grade.

The candidate teachers in the process of pre-service education should have an education in the basis of multicultural education, immigration and the skills about collaborating with refugee children and their parents. Both class and branch teachers should be educated through pre-service and in-service training programs about 'Teaching Turkish for Foreigners'. The authorities must weight on the preventive practises regarding these children's uncontrolled begging on the street and trading water and napkin sales. The necessary precautions must be taken for the children that are out of the formal education in order to incorporate them into the education system even though they are in school age. The collaboration with the Syrian teachers should be the top priority to give psycho-social support for the children exposed to war and trauma as well as the orientation with the training support in the temporary education centers and schools. The improvement of the refugee children's Turkish language skills by protecting their mother tongue and cultural characteristics should be supported. There should be an assistance about the child care service for the mothers that cannot go to school because of their little children and the course facilities to develop the Turkish language skills for the parents should be increased.

## 5. References

- Alhaj, A. (2017). Suriyeli multeciler için gecici eğitim merkezleri: Avantajlar ve dezavantajlar. Retrieved March 10, 2017, from <http://www.depoistanbul.net/tr/index.asp>
- Balkar, B., Sahin, S., & Isikli-Babahan, N. (2016). Gecici eğitim merkezlerinde (GEM) görev yapan Suriyeli öğretmenlerin karşılaştıkları sorunlar. *Eğitimde Kuram ve Uygulama*, 12(6), 1290-1310.
- Boru, N., & Boyacı, A. (2016). Göçmen öğrencilerin eğitim-öğretim ortamlarında karşılaştıkları sorunlar: Eskisehir ili örneği. *Turkish Studies*, 11(4), 123-158.
- Coskun, I. & Emin, M. N. (2016). Türkiye'deki Suriyelilerin eğitiminde yol haritası: Fırsatlar ve zorluklar. Retrieved February 5, 2018, from <http://file.setav.org/Files/Pdf/20160906135243>
- Dallal, Y. (2016). Saving Syria's lost generation through education. *Turkish Policy Quarterly* 15 (3), 107-114.
- Duruel, M. (2016). Suriyeli sığınmacıların eğitim sorunu. *Ataturk Üniversitesi İktisadi ve İdari Bilimler Dergisi*, 30 (5), 1399-1414.
- Emin, M. N. (2016). Türkiye'deki Suriyeli çocukların eğitimi: Temel eğitim politikaları. Retrieved March 10, 2018, from <http://file.setav.org/Files/Pdf/20160309195808>
- Erdem, C. (2017). Sınıfında multeci öğrenci bulunan sınıf öğretmenlerinin yaşadıkları öğretimsel sorunlar ve çözüme dair önerileri. *Medeniyet Eğitim Araştırmaları Dergisi*, 1(1), 26-42.
- Göç İdaresi Genel Müdürlüğü [GİGM], (2016). 2016 Türkiye göç raporu. Retrieved from <https://www.icisleri.gov.tr/goc-idaresi-genel-mudurlugu>
- Hagen-Zanker, J. (2008). Why do people migrate? A review of the theoretical literature. Maastricht graduate school of governance working paper. No.2008/WP002. Retrieved March 9, 2018, from, <https://ssrn.com/abstract=1105657>
- Hatch, J. A. (2002). *Doing qualitative research in educational settings*. Albany: State University of New York Press.
- Maya, I. (2016). İlkokul ve ortaokul öğretmenlerinin çok kültürlü sınıf ortamlarında sınıf yönetiminde karşılaştıkları sorunlar ve bu sorunlar için kullandıkları stratejiler. İçinde K. Beycioğlu, N. Özer, D. Kosar, I. Sahin (Eds.). *Eğitim yönetimi araştırmaları* (ss. 428-434). Ankara: Pegem Akademi. 1. Baskı. DOI: 10.14527/978-605-318-393-8.
- MEB (2014). Yabancılar için eğitim-öğretim hizmetleri. Retrieved from <http://mevzuat.meb.gov.tr/dosyalar/1715.pdf>
- Merriam, S. B. (2009). *Qualitative research: A guide to design and implementation*. Hoboken, NJ: John Wiley.
- Özer, Y. Y., Komsuoğlu, A., & Atesok, Z. O. (2016). Türkiye'deki Suriyeli çocukların eğitimi: Sorunlar ve çözüm önerileri. *Akademik Sosyal Araştırmalar Dergisi*, 4 (37), 185-219.
- Polat, F. (2012). *Türkiye'de öğrenim gören yabancı uyruklu ilköğretim öğrencilerinin karşılaştıkları sorunlar ve çözüm önerileri*. Unpublished master's thesis. Fırat Üniversitesi Sosyal Bilimler Enstitüsü, Elazığ, Turkey.
- Sağlam, H. I., & Kanbur, N. I. (2017). Investigation attitudes towards refugee students of class teachers' in terms of several variables. *Sakarya University Journal of Education*, 7 (10), 310-323.
- Sandal, E. K., Hancerkiran, M., & Tiras, M. (2016). Türkiye'deki Suriyeli multeciler ve Gaziantep ilindeki yansımaları. *Gaziantep University Journal of Social Sciences*, 15 (2), 461-483.
- Saritas, E., Sahin, U., & Catalbas, G. (2016). İlkokullarda yabancı uyruklu öğrencilerle karşılaşılan sorunlar. *Pamukkale Üniversitesi Sosyal Bilimler Enstitüsü Dergisi*, 25 (1), 208-229.
- Taneri, A. ve Tanguş, Z. (2017). İlkokul 4. sınıf öğrencilerinin sığınmacılara bakış açılarının incelenmesi. *Adıyaman Üniversitesi Sosyal Bilimler Enstitüsü Dergisi*, 9 (25), 187-214.
- Tunc, A. S. (2015). Multeci davranışı ve toplumsal etkileri: Türkiye'deki Suriyelilere ilişkin bir değerlendirme. *Tesam Akademi Dergisi*, 2 (2), 29-63.
- UNICEF (2016). *Syrian children in Turkey*. Retrieved March 9, 2018, from, [www.unicef.org/tr/](http://www.unicef.org/tr/)
- Uzun, E. M. & Butun, E. (2016). Okul öncesi eğitim kurumlarındaki Suriyeli sığınmacı çocukların karşılaştıkları sorunlar hakkında öğretmen görüşleri. *Uluslararası Erken Çocukluk Eğitimi Çalışmaları Dergisi*, 1 (1), 72-83.



# Development Of Cognitive Skills Of Hearing Impaired Students

Jale Ipek, Duygu Vargor Vural

## 1. Introduction

Being an important instrument in our daily lives makes the mathematics necessary for each individual of a society to learn it properly. Although the studies dated before 2000s had focused mainly on the content of mathematics, in recent studies it has been tried to explain how mathematics should be thought and which methods should be used for teaching activities. There have been lots of studies on teaching mathematics to the students with learning disabilities with the “Everyone Can Learn Mathematics” principle.

The students with learning disabilities for mathematics are the students who have more problems for learning mathematics than the others, or ones who underperform than the others, or ones who need special education to give adequate performance (Bintas, 2007). There are individuals who have been reported as having at least 20% disability degree on their health certificates have resided intrastate Republic of Turkey [TUIK]. The hearing impaired individuals in Turkey have received their education in different schools at the elementary level (primary and middle schools for hearing impaired), and at the secondary and higher education levels, they have received inclusive education.

An effective education for mathematics to increase the success rate of the students with learning disabilities has been supported by National Council of Teachers of Mathematics (NCTM). The standards of NCTM emphasize that all of the students need algebra beginning from pre-school and proceeding to all levels (NCTM 2000). The new principles and standards on school mathematics have been prepared in order the students to progress with 5 simple goals. The 5 simple goals given below need to be gained by the students by adopting the principle of equality: “Mathematics is for all students without recognizing any personal characteristics, background information and physical characteristics of them” [NCTM].

1. To learn the importance of mathematics
2. To be confident about mathematics skills
3. To be a problem solver in mathematics
4. To learn how to communicate in mathematics language
5. To learn how to think mathematical

It is necessary for disabled individuals to receive education or acquire a profession on an equal basis with the other individuals of the society. Hearing loss is loss of hearing due to the problems from birth or afterbirth. Hearing impairment is a situation occurs for an individual due to the hearing reduction. Hearing impaired individuals have a difficulty of learning since they have problems with the speaking, understanding and comprehension skills due to the hearing loss. Based on their speaking and language problems, they also have difficulties on cognitive, motor coordination, emotional-social, educational, professional and social areas. Although they use hearing instrument, hearing impaired individuals receive the frequency and intensity of the sounds only allowed by the instrument. Therefore they cannot hear some of the speech sounds or they confuse them. They have a difficulty to understand the things that have been spoken based on the distance between the speakers and them, the intensity or tone of the voice of the speaker or background noises. The factors such as the type, degree, configuration, cause of hearing loss and active usage of hearing instrument, the beginning age of the usage, the suitability and adjustment of the instrument for the hearing loss are important for language and speaking development of the hearing impaired individuals [MNE, educational support program for Hearing Impaired Individuals ].

Vygotsky (1965) stated that in development of thought and speech the way is not from individuality to community, it is from community to individuality in his “Thought and Language”.

Consequently Vygotsky brought into prominence to the children thought, which has been assumed primitive and far from reality from infancy by showing that it is for a purpose, in other words to communicate and socialize. And he also conduce education methods to be revolutionised by drawing attention to the success of a child with a help when the related education is above the maturation level of the child. Thus, the importance of socializing and communicating in the educational period was emphasized. Hearing impaired individuals have experienced delays and restrictions to acquire the information and skills which have been acquired by communication due to their disability on language and speaking. Accordingly, they have expressed their thoughts in written or they have not been able to understand mathematical concepts expressed verbally. For instance they have a difficulty to understand the words such as “below”, “right” and “left” in the expression of “Right and left viewpoints of the cube given below” which they encountered in a mathematical question. Concerning mathematics education, when compared to normal students it makes them disadvantaged to understand the words, considering they have no idea about the meanings of these words since they have not used them in their daily lives. Using the sign language for the words and terms, which are suitable for mathematics lessons, cause contradiction in terms. For instance the word “yuz” (a hundred) in Turkish expresses a number mathematically, in sign language it is expressed by showing human face (since the word “yuz” has a number of meanings including “a hundred” and “face” in Turkish) and this makes it difficult for the students to think concepts such as natural numbers and digit value. The hearing impaired students have difficulties on thinking and reasoning, classification and association and explaining skills since the inabilities on their language development. Compared to the students of the same age, they have a difficulty on envisioning in abstract thinking skills. The hearing impaired individuals do not receive auditory stimuli in a similar way depending on the type and degree of the hearing loss. And this causes to have difficulties related to long-term memory and working memory. The hearing impaired individuals have a difficulty in listening and following the verbal directives. They can be distracted easily. They have made much more effort to understand the things in their environment and thus they have easily got tired mentally. Additionally, they can also have difficulties in some skills which require visual motor coordination. The failures which the individual experienced related to learning have created lack of motivation, and dependently those failures have affected the achievements related to learning social relations and academic skills of the individual negatively [MNE, educational support program for Hearing Impaired Individuals].

In conclusion, the mathematically disabled students with need special attention in order them to acquire skills for basic mathematical operations, various conceptual methods and automation. Therefore the direct educational method should be used, especially clear and straight education (Carnie, 1997).

### **Teacher Education on Educating The Hearing Impaired Students**

Council on Teachers of The Deaf, CED prepares teachers with hearing impairment or for hearing impaired students and cooperates with national, provincial or local associations and agencies for various activities, committees and working groups, and accredits university programs. In our country, it has been emphasized at Higher Education Council in 2015 that the necessity for teachers in the fields of teaching mentally disabled, hearing impaired, visually impaired and for the students with multiple disabilities or with superior intelligence under special education has been increasing. In this meeting, it is indicated that the importance of the adequate education which should be received by the teacher candidates in Special Education Field Teaching departments regarding to the education of mentally disabled, hearing impaired, visually impaired, the students with multiple disabilities or with superior intelligence in accordance with the recent developments in special education. Dating from 2016-2017 academic year, courses conforming the international standards for teacher education have been added on the special education teaching programs.

### **The Objective Of The Study**

There are limited studies in the literature of mathematics education for hearing impaired children in Turkey (Kot, M., Sonmez, S., Yikmis, A. & Ince, N. C., 2016). The topics of the studies in this field can be classified as below:

- Comparison of performances of the hearing impaired students and normal students in mathematics,
- The effect of educational environment for the success rate of the hearing impaired students,
- The relationship between teaching mathematics, reading and comprehension and problem-solving performances of the hearing impaired students.

Guldur (2005) has evaluated the behaviours of hearing impaired students for solving mathematical problems depended for operations and observed features of hearing loss, duration of using hearing instrument and chronological age which are thought to affect the problem-solving skill of the students. According to the findings of the study, it was observed that the degree of hearing loss, duration of hearing instrument and chronological age are not the factors which affect the problem-solving skill alone and concluded that the hearing impaired students do not have adequate experiences related to problem-solving skill (Kot, M., Sonmez, S., Yikmis, A., & Ince, N. C., 2016).

The technological advancement in the recent era makes importance increased placed on education. The effort for changing the system of education and the qualification of human power have gained importance. The approaches which focus on disabled individuals and put the individuals in the center have come into prominence with the greater value for humanity. It is necessary to improve qualities and quantities of the teachers who will work in this field since the special education is a special major branch (Ozturk, 2008). Individual works or teamworks can be performed for the education of hearing impaired students. The important thing here is the methods and classroom tasks which the teacher applies. Therefore, the importance should be placed on developing new methods and equipment for disabled individuals in Special Education Undergraduate Programs or material producing courses.

In accordance with all the information given above the objective of this study is to improve problem analysing, comprehension and problem solving skills of the hearing impaired students by making them use basic mathematical skills which should be used in daily life. In line with this objective, a number of activities for hearing impaired students have been prepared. The mentioned activities have been prepared in accordance with the understanding, listening, writing, following instructions, expressing and writing thoughts, working and long-term memory problems derive from hearing loss and for the activities, it has been aimed to present alternative methods / techniques. And it has been also aimed to find solutions for the problems derive from teaching and using materials for hearing impaired individuals. The experiences and observations gained with this study have been expressed for following studies. As a consequence of this study, it has been aimed to popularize the learning environments prepared for the hearing impaired students to learn mathematics all around Turkey. With the study applied, it has been also aimed to make the individuals reach the below goals indicated in the Ministry of National Education educational support program for Hearing Impaired Individuals:

1. Using the hearing residuals at a maximum level,
2. Improving language and speaking skills at the level of the individuals at the same age by using auditory perception skills,
3. Using communication skills in daily life by improving them,
4. Improving reading comprehension, reading and writing skills,
5. Gaining basic mathematical skills,
6. Improving reasoning skills.

The material teaching has an important role for the disabled children since they learn by seeing and touching things. By realizing this fact, M. Montessori, who is one of the influential representatives of pedagogics, has developed several materials related to the different areas of development in order the disabled children to gain some behaviours easily and has concentrated on the education of sense organs of the disabled children (Basaran, 2004). With this object in the study, it has been tried to be



determined whether the activities prepared for this study are effective on the visual perception of the hearing impaired and mentally disabled children from their receptive language skills. The materials prepared for the hearing impaired students are paid attention to be easily found, portable, clear, performable, affordable and suitable for seeing and touching materials.

Being a master in simple operations is somewhat not enough. In addition to the simple operations (Automation Development; Carnie, 1997; Goldman, 1989), the students should also gain problem-solving skills (such as flexibility and adaptation). In this study, it has been aimed for the hearing impaired students to automatise preparatory arithmetics and simple operations and to comprehend mathematical problem-solving methods. Besides, it is also not enough that the students have only mathematical skills to solve mathematical problems; they should know how and when they apply this kind of information when they encounter a new and a similar situation. It has been aimed for solving word problems to teach which operation or method should be applied when and how.

### Method

In this study, case study method from scientific research methods (Cepni, 2010) has been adopted. This approach aims to describe the details of the research subject and reveal cause and effect relationships. In this study, the students with individual differences have been also observed by following the development process of their performances on group works and individual works.

The practice prepared in this direction had been performed in Izmir Tulay Aktas Hearing Impaired Secondary School as 10 course hours for 2 weeks in the spring term of 2017-2018 academic year. The activities prepared for the students had been performed by the 5<sup>th</sup> and 8<sup>th</sup> grade hearing impaired students in company with a special education mathematics teacher. The natural description processes of the students had been observed by preparing them a classroom environment which they can express themselves easily in the research process.

In this study which had been done on the hearing impaired students, it has been aimed perform achievements determined by Ministry of Education. Depending on this objective, the answers have been sought for the problems given below:

- Can he/she count by ones, twos, threes, fours, fives, sixes, tens rhythmically?
- Can he/she comprehend the natural numbers of 1, 2, 3, 4, 5, 6, 7, 8 and 9?
- Does he/she know numerical axis and numerical order?
- Does he/she know two-digit natural numbers and digit values?
- Can he/she add or subtract numbers without carry?
- Can he/she add or subtract numbers with carry?
- Can he/she solve the problems related to addition/subtraction/multiplication/division?

The preliminary test which belongs to the achievements indicated above was performed on 10 hearing impaired 5<sup>th</sup> grade students and 4 hearing impaired 8<sup>th</sup> grade students. After the preliminary test, it was determined that these students have problems on the achievements of;

1. Learning natural numbers and concept of digit, writing the digits properly, showing the numbers on the numerical axis,
2. Analysing the natural numbers,
3. The largeness-smallness relationship between the numbers and numerical patterns,
4. Using skills for four operations while solving problems.

And it was also determined that the students do not know the words and phrases related to the mathematical concepts such as “range the numbers from lowest to highest and from highest to lowest”, “even natural numbers”, “find the number which disrupts the numerical pattern”, “forward, backward”, “after-before”, “to find the difference”, “to share equally” etc., since they are insufficient on using language. In order to teach these mathematical concepts and the terms related to these concepts; a hundred cards, a numerical axis, activities for ordering, counting normal and rhythmically and materials for them were designed (Figure 1: a-b-c). These activities were performed by using methods of showing and making them perform the activities, being a model, showing, clear expression, discussion, drama, induction, deduction, games, repeating, concretization and generalising. The special

## Development Of Cognitive Skills Of Hearing Impaired Students

attention was paid on increasing the activities as many as possible since the achievement of natural numbers is the precondition for the achievement of the four operations skills of the individual (Figure 2: a-b-c).



Figure 1: a-b-c: Activities for counting normally and rhythmically



Figure 2: a-b-c: The materials used

In order to provide effective education, steps for educational method was followed. The researchers have found out that following these steps affects students with learning disabilities to model the patterns, to practice with or without a guide, to receive correct and positive feedbacks with frequent repetitions (Maccini et. al., 1999; Maccini & Hughes, 2000; Maccini & Ruhl, 2000; Mercer & Miller, 1992). Therefore, the works consist of individual works, group works and guided works (Figure 3: a-b-c and Figure 4: a-b-c).

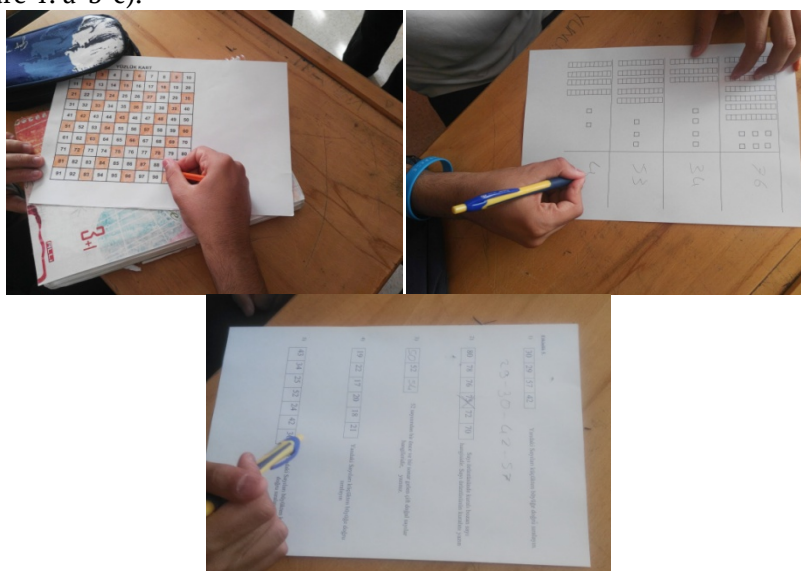


Figure 3: a-b-c: The individual activities of the students



**Figure 4: a-b-c: The group activities with the students**

The biggest problems for disabled students are lack of self-confidence and self-expression. To this respect it was tried to receive feedbacks by calling them to the board and making them attend the activities (Figure 5: a-b-c).



**Figure 5: a-b-c: The Active Attendance Environment of The Students**

In order to attract students' attention and provide motivation for them, each lesson under this study was started with games. And also, each lesson was started with activities which include the former lesson's achievements. According to the rules of the games, group works was performed in twos, in fours and when necessary with all of them. Besides, the games had been prepared as learning-oriented, interesting, exciting and motivation increasing games (Figure 6: a-b-c).

## Development Of Cognitive Skills Of Hearing Impaired Students



**Figure 6: a-b-c: The Work and Game Environment**

### STAR Method

For the second phase of the study, STAR problem-solving technique was used. This method makes students complete the general problem-solving steps and also makes them link between the intermediary steps as a problem solver (Maccini & Hughes, 2000; Maccini & Ruhl, 2000). Although this method generally have been used with integers, it can be also used in different fields in order to improve problem-solving skills. This method was adopted from Mercer and Miller's Strategic Math Series (1991). The main steps of this method are; Search the problem, Translate the words into an equation in Picture form, Answer the problem, Review the solution

The intermediary steps of STAR method are;

1. Search the problem
  - Read the problem carefully
  - Ask yourself "Which facts do I know?"
2. Translate the words into an equation in Picture form
  - Choose a variable
  - Determine the operations
  - Present the problem (concrete part)
  - Present the problem by drawing it (semi-concrete part)
  - Write an algebraic equation (abstract part)
3. Answer the problem
4. Review the solution
  - Reread the problem
  - Ask the question "Is the answer meaningful?"
  - Check the answer

The steps of this method consist of these stages; prepare the regulators (they should make students to be able to identify new skills and also make them think for learning) identify and model, conduct the guided learning, conduct independent learning, perform the last tests, provide positive and decent feedbacks.

After the preliminary test, it was determined that the hearing impaired students are insufficient for presenting problems and finding solutions. The STAR problem-solving technique was reregulated for the hearing impaired students (Table 1). Therefore it was deduced that teaching both presenting the problem (reorganizing the problem which is in the informative format as a visual representation) and solving the problem is necessary for the students. The first two steps of the STAR technique show

the representation of the problem. However, the problems was prepared by dramatizing and drawing pictures since the students was found insufficient to understand the problem due to their insufficiency for vocabulary. For the first problems, some hints (about the operations needed) related to the solutions were given. After the students adopted the method, any kind of hint were not provided. Both the presentations and the solutions of the problems include the questions in the worksheet or prompts. The prompt “Draw a picture of the problem” makes the student recognize the presentation of the problem and the question “is the answer meaningful to you? Why?” makes the student check his/her answer. However the hearing impaired students have had difficulty to draw since they insufficient to understand the picture of the problem. For instance, they had a difficulty to understand the problem since they do not know the meanings of the words “to pay”, “to buy”, “to want”. It was observed that the hearing impaired students could not concretise the abstract concepts. Therefore, the students was made to become experienter-performer by dramatizing the problems (Figure 7 :a-b-c). Besides, the first problems were presented with pictures and after the exercises takes 2 lesson hours, the students were asked to draw the pictures themselves.



Figure 7: a-b-c: Concretion Works

It is necessary to teach the students asking questions themselves when solving a problem. Teaching how to use prompts and questions on the planned worksheet was definitely made them by thinking out loud (reading aloud and answerin the question). The students were asked reproduce the problems and related positive feedbacks were received.

The hearing impaired students have had a difficulty to remember or recall the information. Besides, these students have also had a difficulty to determine and organize the information in the problem. D-Designed worksheets, prompt cards or visual organizers such as graphic organizers help all students to analyse and solve the problem. These organizers also help the students to remember general problem-solving steps/sub-steps and information related to the problem.

**Problem :** Duygu wants to buy a notebook and a pencil. The pencil is 4 TL and the notebook is 8 TL. How much money should Duygu pay in total?




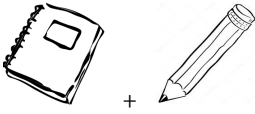
Search the problem  
(a) Read the problem carefully  
and analyse the pictures

(b) Ask yourself

How much money does the notebook and the pencil cost?

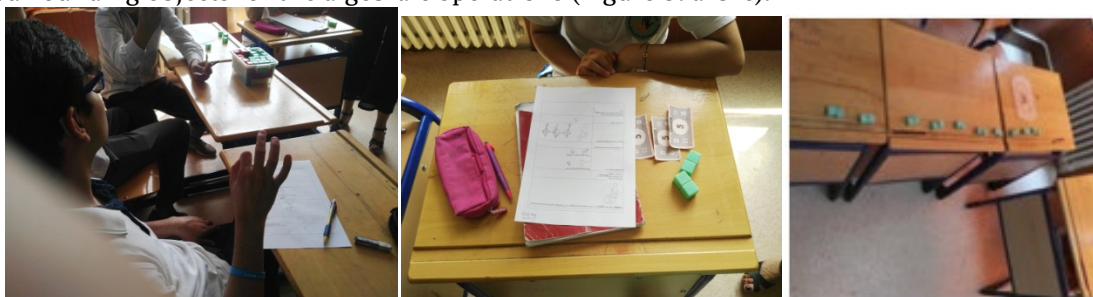


## Development Of Cognitive Skills Of Hearing Impaired Students

(c) How much money will she pay in total?	
Think about the problem whose picture was presented.	
Answer the question	
Re-review the solution. (d) Check the answer, is your answer correct?	

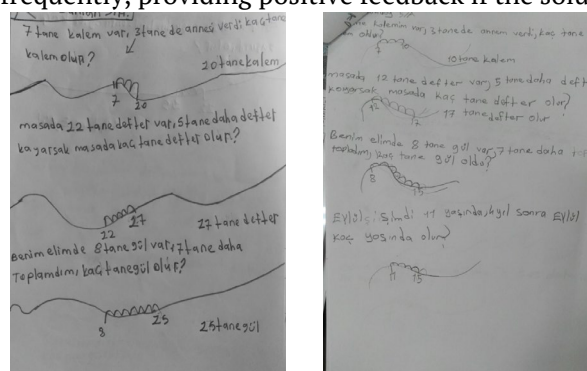
**Table 1: The applied version of the STAR method to the hearing impaired students**

The educational order of *concrete – semi-concrete – abstract* makes the students to understand the content before learning the rules. If only the rules are emphasized, this causes the students to pay minimum attention to the explanations of the content (Bintas, 2007). Therefore, the researchers added some more steps to the effective mathematics education. The researchers used some objects or other concrete materials in order to help the students to present the problem. The students were made to use the surrounding objects for the algebraic operations (Figure 8: a-b-c).



**Figure 8: a-b-c: Concretion Works**

The researchers did not settle with the correct answer, they also asked for the explanations. In the concrete part, the students presented the problem with objects. In the semi-concrete part, drawings of the quantities or pictorial representations were presented (Figure 9: a-b). In abstract part, numerical representations were presented instead of the pictorial representations. By applying this educational order, a success has been achieved for problem-solving methods. Those are; practising guided or independently, repeating frequently, providing positive feedback if the solution is correct.



**Figure 9: a-b Semi-concretion Works**

In the study performed, it was observed that some of the students are underachiever and some of them are overachievers when compared with others. Individual works were performed with these students. The factors such as double disability (mentally and hearing), type, degree, configuration and cause of hearing loss, active usage of the hearing instrument, beginning age of the usage, age of starting

school or special education were considered for the underachiever students. The factors such as having less hearing loss or possessing a speaking skill were considered for the overachiever students. In fact, it was observed that a 5th grader student had better results than the 8<sup>th</sup> grader students in mathematical operation skill.

The study was supported by the interactive computer applications in the Educational Computer Network of The Ministry of National Education. It was indicated by the special education teacher that performing the interactive applications during lessons made learning easier for the students and showed positive results. Besides, it was also emphasized that these applications should be chosen according to the students' level.

### Conclusions

The research question has been indicated as ; “What is the effect of the methods of showing and making them perform activities, being a model, showing, clear expression, discussion, drama, induction, deduction, games, repeating, concretion and generalizing in company with the special education mathematics teacher on mathematical success of the students for improving 4 operations and problem-solving skills? During the answer had been seeking to this question, the attitudes and behaviours of the students were explained by observing the attendance of the students to the activities and how they reach the related conclusions, and all the observations and explanations summarized below.

-The activity 1 A Hundred Cards or Counting Rhythmically which had been prepared based on the question “Can he/she count by ones, twos, threes, fours, fives, sixes, tens rhythmically?” made the students comprehend with semi-concrete examples. They performed this activity with pleasure and easily. In order to explain the digit value, firstly concrete examples, secondly digit cards were used and then it was given as semi-concrete as they given in the activities and was showed as abstract in the last tests. The activities performed have been attached. It was observed that some students switched from semi-concrete to abstract ones without any guidance and consciously. This also shows parallelism with the results of the researches on concrete – semi-concrete – abstract educational order of Mercer & Mercer (1998).

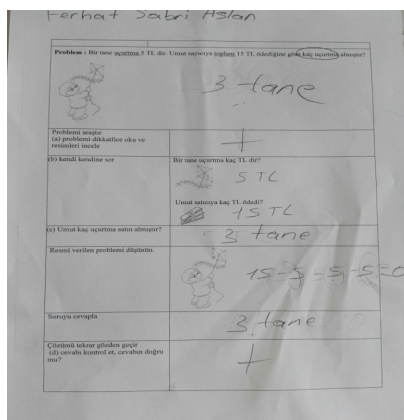
-The activities and games prepared for the question “Does he/she know numerical axis and numerical order?” attracted the students' attention. It was observed that the students adapted the lessons better and did not get bored with these activities. They attended to the lessons actively since they worked with their peers in a group and they were highly motivated. Besides, being in a group activities enabled them to check their peers' mistakes and correct them and help each other. They showed tendency to explain things to each other.

-During the activities prepared for the question “Can he/she add or subtract numbers without carry?”, the hearing impaired students had difficulties to understand the words. The students were supported by special education teacher, some materials were used to enable them to add up and subtract the numbers and the counting operation was concretized. It was observed that the students who has double disability and is new in the special education school counted with their fingers and they were helped with latches, cards, sticks and materials etc.

-For “basic mathematical skills”, the topics taught with the games such as Domino, Matching, Bingo were strengthen and the hearing impaired students were made to automatized preparatory arithmetics and simple operations. Besides, it was observed that the students were in a harmony and they enjoyed when playing games.

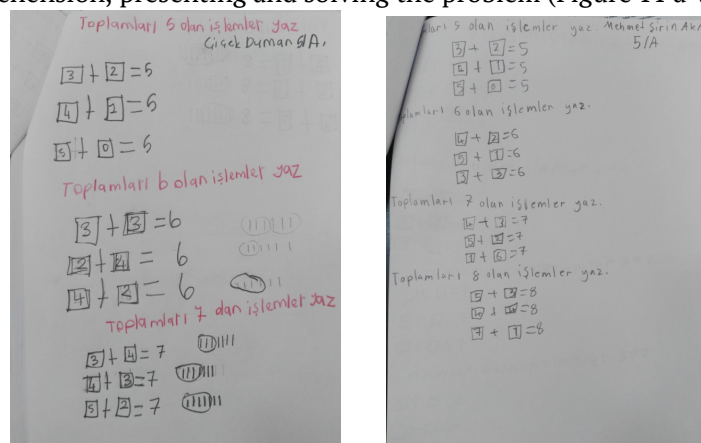
-Some worksheets had been prepared in accordance with the STAR method. The problems in the worksheets had been chosen from real life experiences. The STAR method worksheet which have guiding features were made suitable for the hearing impaired students. The students were made to use their skills in daily life by dramatizing the problems. In Figure 10, an example of a problem solved by a student with STAR method during the education process. Some concrete materials were presented to the students when necessary while they were solving the problems. Thus, it was observed that the students were able to switch between concrete – semi-concrete – abstract easily. It was also observed that the students had a difficulty about the concepts in the problems. For example, since the students

had a difficulty to understand the concept “how many” in the question “A kite is 5 TL. Umut paid 15 TL to the seller in total. So how many kites did Umut buy?”, they solve the problem as  $15-5=10$ . After drawing the picture of the question, with three kite pictures, the students learned the concept “how many”.



**Figure 10 : An Example for A Problem-solving with STAR Method**

The practices include games and activities were performed by all of the students willingly and they were motivated and gave full attention to them. These activities had been prepared as games which include all of the information they had learned in the education process. Performing these activities easily shows that the students have achieved a considerable part of the mathematical skills. It was observed that the students did not forget the achievements they had learned in the former lessons while repeating them in the beginning of each lesson. In the conclusion part of the article “Adapting Mathematics Instruction in the General Education Classroom for Students with Mathematics Disabilities” by Lock (1996), it was observed that presenting real life experiences in order to improve problem-solving skills increases the success rate of the students. In the article “Preparing Students with Disabilities for Algebra” by Maccini (1999), in accordance with the findings of the study related to the improving the problem-solving skills of the students, it was observed that the students improved their reading, comprehension, presenting and solving the problem (Figure 11 a-b).



**Figure 11: a-b An Example of A Problem Comprehension**

In accordance with the experimental research findings given above, it was concluded that the individual, group and guided works influenced the four operations and problem-solving skills of the hearing impaired students. According to the findings of the research, it was determined that the students have gained the aimed achievements by solving problems with methodical education and STAR method.

Besides, as it happened during this research, during the experimental researches mentioned above positive developments were observed on the students’ behaviours and attitudes. And the the opinions of the classroom teacher were also positive. The feedbacks such as “I liked the games a lot” of the



hearing impaired students shows that they made a progress on liking mathematics and taking courage for mathematics.

### Suggestions

In this section, some suggestions have been offered based on the findings of the research. These suggestions are given below as three different parts:

1) Suggestions for training teachers: It should be placed emphasis on how the effective education should be provided in the training process of classroom teachers who have received education in faculty of education and special education teacher candidates, and on the practices and activities related to producing materials. In addition, it is necessary to separate the teachers into different fields regarding to the education of the mentally disabled, hearing impaired, visually impaired students, students with multiple disabilities and with superior intelligence, and also provide their education separately. Since a hearing impaired student have different insufficiency for the skills and abilities from a visually impaired students, the educational methods and techniques should also be different.

2) Suggestions for practice: The practices and activities related to the learning with guides approach for the hearing impaired students should be performed in each stage of the education. During the practices, it was observed that the students which were formerly in inclusive education were underachiever when they compared to the others. The hearing impaired students should receive special education from the special education teacher in the Hearing Impaired Elementary Schools and Secondary Schools instead of receiving inclusive education. The cognitive problems of the hearing impaired students arise from the hearing loss should not be ignored. The main aim for teaching mathematics to these students should be making them gain basic mathematical skills which they need in their daily lives.

3) Suggestions for research: With the cooperation of Ministry of National Education and the Universities, the extended project researches related to the mathematics education of hearing impaired students should be done. The related researches should be connected to the utilization areas of the mathematics and should also help the students to choose their professions. The special education centers should be founded in order to provide mathematics education in each stage for the students who need teachers in the fields of teaching to the mentally disabled, hearing impaired, visually impaired students, students with multiple disabilities and with superior intelligence.

### References

- Basaran, B. I. (2004). Effective learning and multiple intelligence theory: A review. *Ege Education Journal*, 5 (1).
- Bintas, J. (2007). MATHEMATICS EDUCATION FOR STUDENTS DISABLED LEARNING MATHEMATICS. *Education Sciences*, 2(4), 439-450.
- Erdener, E. (2009). Vygotsky's Opinions on Thinking and Language Development: A Critical Look at Piaget. *Turkish Journal of Educational Sciences*, 7(1), 85-103.
- Guldur, F. (2005). Investigation of behaviors of hearing impaired primary school students solving math problems based on four operations. Unpublished post graduate thesis. Eskisehir: Anadolu University Educational Sciences Institute.
- Maccini, P. & Gacnon, C.G. (2000). "Best Practices For Teaching Mathematics To Secondary Students With Special Needs" *Focus on exceptional Children* v:32 no:5 p:1-22.
- MEB, (2008), Hearing Impaired Individual Support Training Program
- Ozturk, M., *Touch of Life-2*, Ilke Publishing, Istanbul 2008.
- Tanridiler, A. (2013). MATHEMATICS TEACHING STUDIES WITH HEARING IMPAIRED STUDENTS. *Education Sciences*, 8(1), 146-163.
- Turkish Statistical Institute ,TUIK (2010). Research of Problems and Expectations of Disabled People.
- Kot, M., Sonmez, S., Yikmis, A., & Ince, N. C. (2016). Effectiveness of spotting technique in teaching handcrafted collecting to students with hearing impairment. *Current Research in Education*, 2(1), 17-28.

# **The Impact Of Peace Education Programme At University On University Students' Tendency To Tolerance**

Soner Polat, Yaser Arslan

## **1. Introduction**

Borders among territories and countries have been removing with globalization and transition to knowledge era processes. Cultures have been interacting each other more than ever before with removing borders. Individuals who are the representatives of various cultures have been interacting with people from different race, ethnicity, religious, sect, language, accent, and culture, willingly or unwillingly. In addition to the impacts of globalization and knowledge era, global war climate, especially in the Middle East, has also caused people's leaving the country. Hence these individuals have interacted with new cultures and people. When the interaction processes have not being peace oriented, interpersonal and intercultural conflicts may be occurred. One of the important factors for living peacefully without conflicts of the individuals from different cultures is having tolerance to others.

Human beings are one of the most important elements of building peace culture process, since peaceful relationships and constructs have been developed with and through individuals. On the other hand, peace should be taught to individuals throughout their whole life since early childhood for integrating peaceful understanding into their lives. Thus, peace education for formal and informal education is a necessity (Polat, 2015). Peace Education Program (PEP) was also applied to the university students and the impact of PEP to the tendency to tolerance scores of university students were tested.

## **2. Theoretical Framework**

### **2.1. Peace**

The concept of peace can be handled and defined in various ways. Peace is defined as the context that constructed via integration, mutual sensibility and tolerance with an emphasis on interpersonal peace by Turkish Language Society (TDK, 2015). Keskin-Cosku and Keskin (2009, p. 72) conceptualizes the peace as "a bundle of values that contains respect to race, sex, religious, and appearance, appreciate to diversity, solidarity, mutualisation, tolerance and being fair". Harris (2002) handles the concept of peace as inner and outer peace on two levels. Inner peace is a status that individuals' taking care and respecting to others. However, outer peace represents the peace status in family, society, culture, and international relations. On the other hand, Galtung (1969) handles peace in two categories: Positive peace, negative peace. Negative peace is defined as minimizing or eliminating war or violence, while positive peace expresses solving disagreements without violence and conflict. One of the most effective ways of struggling discriminatory attitudes, building tolerance and positive peace climate-based societies is providing training for peace education to individuals (UNESCO, 1994).

### **2.2. Peace education**

Peace education is an education process during which related concepts, information, attitudes, skills, and values for living peacefully are taught. In other words, peace education is an education process during which peaceful solutions instead of violence and conflict based solutions to individuals are taught (Polat, 2015). Peace education that adopts an educational perspective for a more fair and peaceful world and which is based on taking action in this direction (Wulf, 1999) is a process during which information and skills as problem solving, cooperation, reflection, conflict resolution, and values as love, respect, tolerance, empathy to individuals and students are taught (Sagkal, 2011). This type of

education aims to solve conflicts without violence and transform individuals' minds for using critical alternatives without violence while resolving conflicts (Reardon, 2002).

Peace education integrates students and teachers to change processes, and also contributes to their peace-based behaviours and their being accommodationist. This contribution proceeds after education, thus peace education makes the environments that are solution oriented possible. Peace education is handled with peaceful pedagogy, and peaceful pedagogy contains the concepts as cooperative learning, democratic society, moral sensitivity, critical thinking, and tolerance (Harris, 2002).

### **2.2.1. The importance of peace education**

A sharing culture that is based on the principles of freedom, justice, democracy, tolerance, and solidarity is a necessity for building peace culture in the global context (UNESCO, 2005). Peace culture should be developed via education to sprout this sharing culture and peace culture's dominating in society (Demir, 2011). On the other hand, the effectiveness and the quality of the education are closely associated with preventing violence, building a trust-based and peaceful climate in schools. To achieve this mission, the alternatives of violence and abilities to live peacefully should be taught to children from early childhood (Harris and Marrison, 2003).

Peace education integrates students to change process, and also contributes to their behaving peace oriented, being accommodationist, developing conflict resolution skills in individual, local, national, and international levels, minimizing tendency to violence, respecting to human rights, and internalizing peace. These contributions are quite important in terms of development and life quality (Salomon, 2002; UNESCO, 2005). Moreover, peace education programs decreases individuals' aggressiveness tendencies and psychological problems, develops constructive disagreement resolution skills, increases self-esteem levels (Sagkal, 2011). Peace education is also seen as one of the most effective ways of building positive peace climate-based tolerant societies (UNESCO, 2005).

### **2.3. Tolerance and tendency to tolerance**

Tolerance is being able to excuse non-adopted opinions and behaviours (Caliskan and Saglam, 2012). In today's world, living together with the representatives of various race, ethnicity, culture, social class, religious, sect, and ideology is inevitable, and the need for tolerance is required more than ever before. Thus, having tolerance is vital in this environment (Tatar, 2009). In this sense, individuals' having high level of tolerance is a key element of building peaceful societies. Tendency to tolerance of individuals can be increased via various experiences and trainings. Peace education can also be handled as this type of training. PEP which is the independent variable of this study also aims to increase participants' tendency to tolerance. Hence, this study aims to investigate the impact of PEP on university students' tendency to tolerance.

## **3. Methodology**

### **3.1. Model of the study**

Single group pre-test post-test model, a type of pre-experimental designs, was used in this study. Independent variable is applied to participants, and measurements are carried out both before experiment (pre-test) and after experiment (post-test) in the single group pre-test post-test model. If post-test scores are more than pre-test scores, it is accepted that this gap between scores is considered to result from independent variable (Karasar, 2008). In this study, with the purpose of examining the change in university students' tendency to tolerance scores pre-test was applied to the participants before starting programme, post-test was applied to the participants after the programme, and difference or lack of difference between pre-test and post-test scores were analyzed, too.

### 3.2. Participants

The participants of this study consists of 38 university students from different faculties who took and attend Peace Education course which was an elective course at Kocaeli University in Turkey in 2014-2015 academic year. Of participants, 13 are male, 25 are female. Of those students, 19 study at sciences, 17 at social sciences, 1 at arts, and 1 at sports.

### 3.3. Data collection tool

Data of the study were gathered via Tendency to Tolerance Scale which was developed by Caliskan and Saglam (2012). Five-likert typed scale contains five options as (1) Strongly Disagree, (2) Disagree, (3) Neither Agree nor Disagree, (4) Agree, and (5) Strongly Agree for each item. There are nine items in value sub-dimension, five items in acceptance sub-dimension, and four items in empathy sub-dimension. Totally, the scale contains three sub-dimensions and 18 items. Caliskan and Saglam (2012) found Cronbach's Alpha value as 0.89 for the entire scale, and 0.86, 0.70, 0.63 for the dimensions, respectively. Re-test reliability score for the entire scale was found as 0.84. Re-test reliability scores of the dimensions were found as 0.83, 0.73, and 0.82.

### 3.4. Peace education program

PEP that lasted 14 weeks and 28 hours was applied to participants of this study. PEP's primary purpose was bringing methods and strategies which are requirements of living together peacefully in societal life to the university students. With this aim, a programme was designed to develop university students' physical, psychological, and social environments; viewpoints to individual differences; communication, empathy, tolerance, anger management, problem solving, and peacemaking abilities. There was a session for each week in the programme, and each programme's duration was two hour. The contents of the session, respectively as follows: (I) The concepts related with peace education, (II) The reasons that require peace education, (III) Professional and characteristic features of the peace education teacher, (IV) The purposes of peace education and examining curricula via peace education lens, (V) The content in peace education and examining curricula in this respect, (VI) Preparing learning environments in peace education and sample activities, (VII) Communication skills and empathy for peace, (VIII) Communication skills and tolerance for peace, (IX) Peaceful problem solving ability and sample activities, (X) Emotion management in peace education, (XI) Anger and conflict management in peace education, (XII) Peacemaking in peace education and sample activities, (XIII) Designing activities for peace education, (XIV) Micro teaching practices based on peace education.

## 4. Findings

The main hypothesis of the study is " $H_1$ . There is a significant difference between participants' pre-test and post-test scores of tendency to tolerance." The sub-hypotheses are;

- " $H_{1a}$ . There is a significant difference between participants' pre-test and post-test scores of value sub-dimension."
- " $H_{1b}$ . There is a significant difference between participants' pre-test and post-test scores of acceptance sub-dimension."
- " $H_{1c}$ . There is a significant difference between participants' pre-test and post-test scores of empathy sub-dimension."

With the purpose of testing the hypotheses, participants' pre-test and post-test scores of tendency to tolerance scale were tested via Wilcoxon signed ranks test. Analysis results were given in Table 1.

**Table 1.** Wilcoxon signed ranks test results for participants' pre-test and post-test scores

Posttest scores – Pretest scores		n	Mean rank	Sum of ranks	Z*	P
TENDENCY TOLERANCE	Negative ranks	15	18,63	279,5	-1,321	0.187
	Positive ranks	23	20,07	461,5		
	Ties	0				
Value	Negative ranks	14	16,39	229,5	-0,913	0.361
	Positive ranks	19	17,45	331,5		
	Ties	5				
Acceptance	Negative ranks	11	18,27	201	-2,278	0.023
	Positive ranks	26	19,31	502		
	Ties	1				
Empathy	Negative ranks	13	16,73	217,5	-0,6	0.549
	Positive ranks	18	15,47	278,5		
	Ties	7				

*\*based on negative ranks*

Analysis results shows that there are not any significant differences between participants' pre-test and post-test scores of tendency to tolerance ( $z=-1,321$ ,  $p>.05$ ). When sum of ranks and mean rank are considered, it has been found out that the difference between pre-test and post-test scores is in favour of post-test scores, it is seen that this difference is not significant. According to this, it can be said that PEP helps participants' tendency to tolerance scores increase, but this increase is not significant statistically.

Analysis results of the hypotheses related to sub-dimensions indicates that there is a significant difference between participants' pre-test and post-test scores of acceptance ( $z=-2,278$ ,  $p<.05$ ). Sum of ranks and mean rank indicate that the difference between pre-test and post-test scores is in favour of positive ranks score. This result can be interpreted as participants' acceptance scores were increased via PEP.

Analysis results of other sub-dimensions show that there are not any significant differences between participants' pre-test and post-test scores of value ( $z=-0,913$ ,  $p>.05$ ), pre-test and post-test scores of empathy ( $z=-0,6$ ,  $p>.05$ ). According to these results, though there are differences in favour of post-test scores for value and empathy sub-dimensions, it can be said that PEP did not show the expected effect.

## 5. Discussion

According to the results, though there are differences between the pre-test and post-test scores of tendency to tolerance, the pre-test and post-test scores of the sub-dimensions of value and empathy are in favour of post-test scores, it is seen that these differences are not significant statistically. Thus, it can be said PEP did not show the expected effect. The reason of not revealing expected effect for these sub-dimensions can be that PEP does not have any activities which are based on experiences for these dimensions. Hence, improving PEP in this way can be suggested for increasing and learning tolerance (Demirtas, 1991; Harris, 2002; Onal and Arsal, 2015).

PEP revealed significant difference between the pre-test and post-test scores of acceptance that is a sub-dimension of tendency to tolerance. This result can be interpreted as university students'

acceptance levels can be increased via PEP. On the other hand, while there is not any significant difference in terms of some dimension, it is seen that PEP increased participants' mean scores. Thus, it can be asserted that the program can be used for building peace and increasing tendency to tolerance after a revision.

PEP was applied a group of university students in this study, and programme achieved its aim limitedly. It can be suggested that the effectiveness of PEP can be tested by conducting studies with various and larger groups using different experimental methods.

## References

- Caliskan, H., & Saglam, H. I. (2012). A study on the development of the tendency to tolerance scale and an analysis of the tendencies of primary school students to tolerance through certain variables. *Educational Sciences: Theory & Practice*, 12(2) [Supplementary Special Issue], 1440-1445.
- Demir, S. (2011). An overview of peace education in Turkey: Definitions, difficulties, and suggestions: A qualitative analysis. *Educational Sciences: Theory & Practice*, 11(4), 1739-1745.
- Galtung, J. (1969). Violence, peace, and peace research. *Journal of peace research*, 6(3), 167-191.
- Harris, M., I. (2002). Conceptual underpinnings of peace education. In G. Salomon & B. Nevo (Eds.). *Peace education: The concept, principles, and practices around the world* (pp. 15-25). Mahwah: NJ: Lawrence Erlbaum Associates Publishers.
- Harris, I. M., & Morrison, M. L. (2003). *Peace education* (2nd ed.). Jefferson, NC: McFarland & Co. Inc. Publishers.
- Johnson, D. W., & Jonhson, R. T. (2005). Essential components of peace education. *Theory Into Practice*, 44(4), 280-292.
- Karasar, N. (2008). *Scientific Research Methodologies*. Ankara: Nobel.
- Keskin-Cosku, S. & Keskin, Y. (2009). Peace as a value in social studies course (Cumhuriyet Donemi Ilkokul Ilkogretim 1. Kademe Sosyal Bilgiler ve Onun Kapsamina Giren Ders Programlarında Bir Deger Olarak "Baris" in Yeri). *Journal of Values Education*, 7(17), 69-92.
- Onal, G., & Arsal, Z. (2015). Peace education in primary and secondary school curriculum. *The Journal of Abant Izzet Baysal University Faculty of Education*, 15 [Supplementary Special Issue], 176-191.
- Polat, S. (2015). Peace and empathy in the context of other's view (Otekine bakis baglaminda baris ve empati), In Y. Kabapinar (Ed.). *Developed with and developing empathy: Child and empathy (Empatiyle gelismek empatiyi gelistirmek: cocuk ve empati)* (pp. 135-153). Ankara: Pegem Publishing.
- Reardon, B. (2002). Human rights and the global campaign for peace education. *International Review of Education*, 48(3-4), 283-284.
- Sagkal, A., S. (2011). *Investigating the effect of peace education program on the sixth grade elementary students' aggressiveness tendencies, empathy levels and perceptions related to peace*. Unpublished master thesis, Dokuz Eylul University, The Institute of Educational Sciences, Izmir.
- Salomon, G. N. (2002). The nature of peace education: not all programs are created equal. In G. Salomon & B. Nevo (Eds.), *Peace education: The concept, principles, and practices around the world* (pp. 3-13). Mahwah: NJ: Lawrence Erlbaum Associates Publishers.
- Tatar, A. F. (2009). *Tolerance education in preschool education (5-6 years)*. Unpublished master thesis, Ankara University, The Institute of Social Sciences, Ankara.
- Turkish Language Society, (2015). *Turkish – Turkish Dictionary*. Retrieved November 4, 2015, from <http://www.tdk.gov.tr>
- UNESCO. (1994). The Salamanca Statement and Framework for Action. Paper presented at the World Conference on Special Needs Education: Access and Quality, Salamanca, Spain.
- UNESCO. (2005). *Framework for teachers*. India: New Delhi.
- Wulf, C. (1999). *The other in peace education, peace education: context and values*. Gennanio: Pensa Lecce Multimedia.



# Instructional Supervision at Secondary Schools

Osman Ferda Beytekin, Sekibe Tas

## 1. Introduction

Instructional supervision helps to determine the level of realization of educational objectives as a sub-system of educational management. The system is a process consisting of inputs, processes and outputs and it is necessary to get information about these steps, to evaluate this information and to improve or correct the objectives of the organization according to the results. In this context, instructional supervision provides feedback to organizations, increases the effectiveness of self-directed organizations through audit results and improves problem-solving abilities. An organization that wants to maintain its own existence must absolutely self-assess with an instructional supervision and know and observe whether it achieves the goals it has set. This is possible with the planned and programmed close monitoring of the process and outputs of the entrances, and taking measures to continuously increase the entrances (Memduhoglu, 2012; Rata, Runcan and Arslan, 2013). Since these measures can be provided by instructional supervision, an appropriate control system should be designed by analyzing all aspects of the organization. Within the education system, there is a self-renewal process that comes with the supervision. In this direction, instructional supervision has evolved in the historical process according to the circumstances of the present day. Nowadays educational organizations can not be expected to be governed in accordance with the classical of management theory because it is a social system. In an organization in which a person is seen as a machine, relations that make up the organizational structure do not allow people to realize themselves. Excessive commitment to legal documents and rules causes legal documents to become as a goal not a tool. Management and supervision with an authoritarian understanding of the past can prevent teachers and students from achieving satisfaction from the work they do (Kapusuzoglu, 2008).

The thought that teaching process is one of the educational supervision approaches to judging the teacher has left the place to think about guidance and help in teaching. In the studies conducted, supervision is generally limited to control and evaluation, and there is a need for a structural system change and mentality renewal in educational supervision. In audits, formal items such as plans, documents, files are kept on the front line and the direction of guidance and counseling is ignored or the second plan is being taken. Contrary to the function of the modern supervisor as a developer, there is no guiding activity for teachers to develop negative situations. What teachers are doing more is being assessed, and what they can do to improve it is neglected. This practice does not fit into the controller's leadership, instructional, guidance and assistance roles. A healthy process of the audit is possible by knowing what the teachers' perceptions and expectations about this process are (Memduhoglu, 2012; Boydak and Sener, 2015, Arslan, 2018). In the Turkish education system, fundamental reforms, new approaches and effective measures are needed in order to improve the learning-teaching process in accordance with the instructional supervision understanding, to provide the necessary professional help to the teachers in this direction and to increase the effectiveness of the audit services (Erdem, 2006; and Rich, 2012; Zepeda, 2016).

It is stated in the Teacher Audit Guide published by MEB (2011) that the teachers should be supervised in two parts according to the form. In the first part, paper examination and in the second part, evaluation areas related to course observation are included. The performance indicators prepared within the scope of teacher general qualifications are used for course observation. In accordance with this guideline, supervise teachers other than the school supervisory group give written statements to the concerned supervisory group, together with the names, explanations and suggestions of the supervisors they supervise. The supervisor reports the place, the time and the documents he will meet with the teacher according to the programs that existed before entering the course so as not to interrupt the education at the school during the preliminary stage. At the time of getting acquainted, he meets with the teacher at the place and time that previously determined. It informs the teachers about the



information and documents they would like and plans the class time to be watched according to the teacher's request. The supervisor observes the course carefully to assess the teacher's situation and to reveal the areas of development when needed.

It is important that the supervisor make a planning of the applications to be carried out before and after the audit. The supervisor must be both an expert in the program and a subject matter expert in order to identify and develop the teacher supervisor relationship before the supervision, to plan more effective supervision and to implement the teaching process by the supervisor and the teacher, to monitor, analyze and evaluate the class activities. In order to enable teachers and supervisors to analyze the teaching-learning activities simultaneously during the supervision phase, it is necessary to obtain data by appropriate methods and techniques. The teacher further develops these by emphasizing the determined strengths of the observed end result; the supervisor and the teacher produce solutions together in order to correct the mistakes and to strengthen the missing directions. We try to reach a common view through solutions and try to improve the teaching process. At the same time, audit process is supervised after audit. There is no time limit for effective supervision (Koklu, 1996; Rata, Arslan, Runcan, & Akdemir, 2014 ). Given the imbalances in the number of modern auditing approaches, changes in auditing and assessment content, changes in the roles and responsibilities of school administrators, the number of auditors, schools, and teachers, the audit activity of school principals will come to prominence. In this case, the supervisory activities of school principals become inevitable events. In addition, school principals are seen as leaders of teaching and perform very important functions in improving the performance of school stakeholders (Yilmaz, 2009). Inspectors, school principals, or anyone who undertakes supervisory tasks are influential in the development of all the items that go into auditing to plan and conduct the audit they will be performing.

At present, many applications related to instructional supervision have not yet established an effective supervision system. Teachers are having difficulty adapting to changing supervisory systems in a short period of time, which weakens the direction of improvement and improvement of supervision. In this study, it is aimed to determine the information about the teacher supervision of the secondary school teachers, to acquire information about the practices of the principals related to the instructional supervision process, the difficulties they encountered during the process and the proposals about this process. In response to this objective, the following questions were sought:

- What is instructional supervision according to the secondary school teachers?
- How do secondary school principals carry out the phases of preparation, implementation and feedback of the instructional supervision process according to the secondary school teachers?
- What are the difficulties of secondary school teachers during the instructional supervision process?
- What are the proposals of secondary school teachers for the development of instructional supervision?

## 2. Method

The research was carried out using qualitative research model. Qualitative research can be defined as a qualitative research process in which qualitative data gathering methods such as observation, interview and document analysis are used, in order to reveal perceptions and events in a natural and realistic way (Yildirim and Simsek, 2008). In this framework, the case study, which is one of the qualitative research methods, has been used in the research. The working group of this study was identified using easy-to-reach sampling from purposeful sampling methods, as it is qualitative. This sampling method brings speed and practicality to the researcher. Because in this method the researcher chooses a situation that is close and easy to access (Yildirim and Simsek, 2008). The working group of the study is composed of 15 teachers who are working in 3 secondary schools selected by the easily accessible sampling method in the province of Bornova Izmir in the academic year of 2016-2017. The selection phase was carried out on the basis of the secondary school information on the official web site of the Bornova District Directorate of Education, by reviewing the statistical information found on the official website of the

Bornova District Governorate. Six of the teachers who participated in the study were male 9. No information about the identities of the participants was given and the participants were coded as K1, K2, K3, K4, K5, K6, ....., and K15, and their statements in the interviews were included in the findings as evidence supporting the findings.

### 2.1 Data Collection

The research data was provided by a semi-structured interview form. According to Patton (1987), the view is to enter into the inner world of an intentional individual and to understand his point of view. Through interviews, we try to understand what experiences, attitudes, thoughts, intentions, interpretations, and mental perceptions and reactions can not be observed. The main objective of the interviewer is to ensure that the other side is in a comfortable, honest and correct reaction to the questions posed in this process (Yildirim and Simsek, 2008). Attention has been paid to the open-ended questions that participants should be able to easily respond to, while avoiding inquiries from multidimensional questions, directing them to be easy to understand, subject- and reason-focused while preparing interview questions. The interview form prepared by the researchers was presented to the expert approval and made necessary corrections to make the data collection process ready. Content analysis method was used for data analysis. Through content analysis, attempts are made to reveal the truths that may be hidden within the data. The main work in content analysis is to bring together similar data within the framework of certain concepts and themes and to interpret them in a way that the reader can understand (Yildirim and Simsek, 2008). For the analysis of the data, the data were read three times. After the reading process is completed, codes are set for each participant response. After the code and concept determination phase, the theme is reached. After the themes have been formed in the data analysis process, adequate appearing citations have been chosen to explain the findings. While the findings were interpreted, they were supported by the text, interpreted with meaningful and consistent explanations, and supported by quotations.

Expertise in the survey and internal validity were tried to be achieved through participant confirmation. The research process and the processes carried out in this study are described in detail in order to increase the external availability of the research. In this context, the model of the research, the study group, the data collection tool, the analysis of the data and how the findings are organized is presented in detail. In order to increase the internal reliability of the study, all of the findings were given directly without comment. It has been tried to provide external reliability by requesting other researchers or storing raw data of researching with the aim of making comparisons in another research in the future.

## 3. Findings

### 3.1 Instructional Supervision

In the study, the research question “What is the instructional supervision according to the secondary school teachers?” has been directed for the determination of the information related to the concept of instructional supervision. In order to this question teachers were asked “For you 'Instructional Control'? Identify”.

In the answers given, instructional supervision has been observed to focus on observation, improvement, development and guidance, and the theme is determined as “Improvement and Development”. Participants expressed their views on the theme of instructional supervision as follows:

K2 *“Instructional supervision is the observation of practices within the course to improve and improve success.”*

K3 *“It is the monitoring of instructional supervision based on constructive criticism.”*

K4 *“I think that one educator is actively being observed and evaluated by another person in the education and training process he / she is living with. If there are incomplete aspects of this evaluation, elimination should be made better.”*

K8 *“Supervision by the manager to determine the missing areas (course processing or document preparation) and to prepare a better teaching environment.”*

K9 *“It is the process of defining, developing and eliminating deficiencies in the direction of the organization.”*

K10 *“Improving teaching is all the work done to improve teacher capacity to ensure teachers' progress.”*

K14 *“Instructional supervision is a system that enables teachers to develop and improve teaching by experts.”*

### **3.2 Progression of Instructional Supervision**

According to the second research question, “How do secondary school principals carry out the phases of preparation, implementation and feedback of the instructional supervision process according to the secondary school teachers?” teachers were asked to evaluate the preparation, implementation and feedback phases of the three sections separately and asked as “How does your principal conduct the instructional supervision process? Please evaluate according to the stages of preparation, implementation and feedback.”

Teachers stated that during the preparatory phase, situation analysis, informing and planning were done, the theme was designated as “Planning”. School principals are preparing the appropriate lesson time and noting the teachers to be included in the planning, the form for the lesson to be supervised. The opinions regarding the inspections made by this method are listed below.

K4 *“Determining the criteria to be evaluated and controlled and arranging in the form of observation.”*

K5 *“The principal informed me that he was going to watch.”*

K8 *“The school principal will notify in writing what documents will be requested and what subjects will be checked during the year's supervision.”*

K11 *“The teacher who received the course had information about which course was appropriate. She has shown a classy attitude by taking a kind of appointment. Prepared according to class and course.”*

K12 *“At the beginning of the school year, the procedures for class visits and the purpose of class visits are declared.”*

K13 *“The school principal has made it possible for teachers to select the supervision hours in order to inspect them in accordance with their plans.”*

K15 *“Teacher informs before supervision. It gives information about the elements to be supervised. It determines the inspection time and makes plans for it.”*

During the implementation phase, the teachers have indicated that they are mainly in-class observation and monitoring, and the theme is determined as “Observation”. According to the opinions of the participants, the school principals come to their lessons during the practice and evaluate the course in terms of curriculum compliance.

K2 *“Follows the practices during the course. It monitors the events made in terms of curriculum appropriateness.”*

K3 *“It is realized by the school principal that the teaching period is monitored for a certain period of time.”*

K4 *“Observing the class during the day and hour that the schoolmaster identifies. Fill the form.”*

K6 *“The studies to be carried out according to the annual plan are also indicated in the class books. The school principal monitors the success of the course and whether it should be as instructed.”*

K8 *“The day ahead will be announced to the course supervision. On that day, he listens to his lectures with the necessary documents and takes the documents. Then give a date for the evaluation and thank you.”*

K13 *“The school principal did not limit the auditing process to just one lesson, but continued throughout the year.”*

In the feedback phase, it was emphasized that the guidance activity was carried out as the result of the evaluation and the theme was designated as “Guidance”. At this stage, school principals report all their positive or negative views after the evaluation. In terms of positive aspects, it is seen that they are

## Instructional Supervision At Secondary Schools

following a motivational way of teaching and they are presenting suggestions to eliminate this negativity.

K5 *“At the end of the lesson he expressed his pleasure. I reminded that I could use different methods.”*

K6 *“He will provide feedback through positive talking and behavior after the control of the applications.”*

K8 *“He will report the shortcomings of the document check, and make suggestions on how to fix it.”*

K11 *“Observations made have been guided by the teacher. Observed results are transferred.”*

K13 *“Our school principal gives all positive or negative feedbacks outside the objective and classroom environment.”*

K14 *“Post-supervision analysis is done. Identify missing directions and find recommendations. Motivational promoting talks are held for positive aspects.”*

### 3.3 Difficulties Encountered in Instructional Supervision Process

The question “What are the difficulties you face in the lecture supervision process?” was directed to the teachers for the third research question, “What are the difficulties of secondary school teachers during the instructional supervision process?” Some of the teachers think that there is no difficulty, but the majority think that supervision in the classroom has a negative effect on the classroom environment and the students. It is emphasized that this negative effect is caused by the insufficiency of the supervisor about instructional supervision. In this respect, the theme for this research question is “the Lack of Information and Experience in the Supervision”. Teachers stand on two points in this regard. The first is the difficulty arising from the lack of supervision taking into consideration the teaching requirements. At the same time, it is compulsory for teachers to break out of the classroom environment and to take the class out of the way. Participants thus expressed their views as follows.

K6 *“I believe that we don’t show ourselves in supervision process because I think that the conditions of teaching are inadequate and that the desired environments are not formed.”*

K11 *“Students are not comfortable. The existence of an authority other than the teacher in the school affects the functioning of the course absolutely. School manager, inspector or publicity etc. The presence of any professional person who comes to work has a different impact on the class. For this reason, the day is actually different than the course is normally. This prevents the supervision from being healthy.”*

K13 *“The difficulty of instructional control can cause instantaneous different reactions in the classroom environment. Students are not accustomed to see the principal join the class. For this reason, the students who participate in the course actively can withdraw themselves. I have witnessed in my supervisors of my professional life that my students always wanted to get to know our principal more closely.”*

The second is due to lack of information about the supervision. K10's say his opinion on this as “Very few people have information about instructional supervision.”

Similar to K10, K14 and K15, say,

*“The fact that the supervisor's branch is different from the supervised teacher's branch does not constitute a proper supervisory process. The feedback is also missing. A guest in the class breaks the classroom's environment. Problems that exist in the class do not appear.”*

*“The feedback is weak if it is not in the same branch as the principal. The principal is trying to figure out what is done to follow the lesson so that it is not possible to make a positive or negative assessment. We do not know exactly what is supervised, I think he does not know either. It's done to be done.”*

### 3.4 Suggestions for Improving Instructional Supervision

For the fourth research question, “What are the proposals for the development of instructional supervision of secondary school teachers?”, The question was asked as “What are your suggestions for

the development of instructional practice?" Although various proposals have been made, it has been mentioned that the supervision is mainly based on the objectivity of supervision, supervisor and teacher have the same branch, necessary to carry out inspections according to certain scales and criteria and to perform the inspections at certain intervals. In this direction, the theme is defined as "Improvement of Expertise Related to Supervision".

K2 *"Appropriate branch of principal must be assigned."*

K10 *"Those who will carry out the supervision are required to do this within the framework of certain criteria and within a scale. In addition, specializations must be taken into account when carrying out these inspections."*

K8 *"Instructional supervision should not be done in one lesson, should be spread to the process. And generally should be guided by the principal. Must be constructive, not destructive."*

K13, emphasizing the necessity of conducting evaluation in the supervision of instructional supervision:

*"I think the frequency of instructional supervision should be increased. It is absolutely necessary for the teacher to be assessed by the school principal for internal discipline and development of the teacher. Experience, make your teacher always better and beautiful. For this reason it should be kept under control of the teacher role in the whole education and training process."*

Contrary to K13's view, K14 mentioned the necessity of an expert supervisor in a field as;

*"Supervisors should not be school principals. Because they ignore the problems arising from their own managerial deficiencies. They can not be planned because they are very busy. It should be supervised by experts in some fields. School conditions must be considered. Motivational feedback should be provided and supervisions should be repeated at specific intervals."*

Apart from all these suggestions, K4 suggest distance supervision;

*"Classes can be observed by a camera with. Two or three classes can be choosed for equality. In those classes, you can register for a week without interrupting and telling when it will watch. Both teachers are partially prepared and do not role because they do not know when to be. You'll have a chance of equal evaluation of all teachers."*

#### **4. Discussion And Conclusion**

It is seen that teachers' answers to the definition of instructional supervision in the study are defined an improving and developing process. The conceptual knowledge of supervised and supervisor in instructional supervision affects the perspective and practices of the process. The supervised and supervisor who can not meet in the common payer can interfere with the efficiency in instructional supervision. In the qualitative study conducted by Beytekin and Tas (2017) in order to determine the opinions of the school principals about the instructional experience, the principals were asked about the concept of instructional supervision and the principals defined the concept of instructional supervision as regulatory, planned, interactive, cooperative, problem solving and professional development process . In this study, teachers' view of instructional supervision as a curative and developmental process shows that the supervised and the supervisor can form a common conceptual view.

Instructional supervision process was examined through preparation, application and feedback stages and opinions were received from each of the teachers. Teachers are talking about the fact that school principals are planning for supervision during the preparation phase, using the form for planning and informing the teacher about the application. They emphasize that during the course of

the practice there are often in-class observations and that these observations are limited to the evaluation of the curriculum. In the final phase of the feedback phase, the positive and negative aspects are shared with the teachers; guidance is given by teaching suggestions for those who are negative. The results of the study conducted by Aktepe and Uluc (2014) show that school principals can not help teachers adequately in the curriculum and the educational and teaching activities in the classroom environment. Teachers have stated that administrative tasks in school are preceded by educational affairs, which are inadequate in the management of curriculums and educational curriculum of the administrators.

Teachers indicate that the challenges they face most during instructional supervision are the lack of knowledge about the branches they supervised. In addition, teachers emphasize that the existence of an auditor within the class corrupts the class environment and goes beyond the normal course of the course, which negatively affects the supervision process. Boydak and Sener (2015) examined the teachers' perceptions of the supervision process with their work; this process has come to the conclusion that there are teachers with negative perceptions as well as teachers who perceive positively. Teachers with positive perception; assessing the work carried out by the supervisor, determining the deficiencies and eliminating these deficiencies, achieving the desired level of success, improving the disadvantages by providing process improvement and investing in the future to maintain the existence of the system. On the other hand, teachers with negative perceptions suggested that the supervision was conducted for explicit search and control purposes, which resulted in pressure and fear.

Teachers present solutions for the challenges they face in instructional supervision. First of all, the necessity of an expert supervisor suitable for each branch is emphasized. They are proposing a standard supervision, stating that each time they should be used, appropriate criteria and scales should be used. Supervision is not limited to only one lesson during the year, but it is recommended that the supervision must be conducted at regular intervals. Unlike these, a participant advised to perform the instructional supervision remotely so that the classroom functioning does not distort with the presence of any supervisor, and that a natural supervision will be made, and thus the frequency of supervision can be increased.

Although teachers have a specific definition of the concept of instructional supervision, all human resources involved in the supervisory process should be trained on theoretical and practical instructional supervision, and instructional supervision should be based on a scientific basis. In this way, an infrastructure related to instructional supervision can be formed, and methods and techniques aiming at the denial can be used through more reliable bases. In this direction, it is advised to teach supervision courses in undergraduate education and to eliminate the deficiency information that exists with in-service trainings.

Teacher and principal cooperation is great importance in instructional supervision. Despite the fact that there is still no consensus on how to carry out instructional supervision, studies are underway and various systems are being tested. The use of pre-tested scales and forms is recommended so that an objective assessment can be made in the process of implementing the supervision. All principals should plan what to do in the preparation, implementation and feedback phases through a common template at the beginning of the year and share it with the people to be supervised. According to the information obtained by Beytekin and Tas (2017), where information on the instructional supervision process is obtained, it is seen that in the prepreparation stage of the principals, they have taken a way to collect information for preliminary preparation, to inform teachers about the process and to plan accordingly. In the application phase, they benefit from classroom observation; and more guidance / counseling activities in the feedback phase. In the direction of this data, the practices and opinions of the principals and teachers about the instructional supervision process are similar.

Taking into account the difficulties with regard to instructional supervision, it seems that school principals who assume the role of supervisor are obstacles to efficient control of work intensity. In this respect, it is proposed to make some regulations in the legislation so that the supervisor's authority can be used to other persons or the workload of principals is reduced. As a result of an instructional supervision study conducted with elementary school teachers, it has been seen that primary school

teachers mostly commented on the supervision of course supervision. As a justification for the withdrawal of the lecture supervision, they stated that the evaluation in the short term would not be a complete assessment and that the supervision of non-specialists in the field (not in the same branch) would be lacking. It is another finding of this research that teachers do not see school principals as specialists in fulfilling the duty of course supervision. Participants did not see the school administrators as experts in course supervision, nor did they want the supervision of the course to be done by inspectors (Koybasi et al., 2017). Within these problems, it seems that the problems related to the concept of supervision, the problem of implementation arising from the fact that the concept is unknown, and the disconnection between the supervisor and the teacher are also reached in this study.

It is thought that this study can be applied in the form of remote control with the use of technology, not the intervention of instructional supervision. It is proposed that a system to be established should periodically monitor and evaluate the current nature of the classes without deterioration and to develop a system in which audiences will supervise their own areas of expertise. In addition, it is important for auditors to follow and read domestic and international publications in terms of personal and professional development.

## 5. References

- Aktepe V. ve Buluc, B. (2014). Sınıf Öğretmenlerinin Algılarına Göre Okul Yöneticilerinin Öğretim Liderliği Özelliklerinin Değerlendirilmesi. *GEFAD / GUJGEF* 34(2). 227-247.
- Arslan, H. (2018). An Introduction to Education. London: Cambridge Scholars Publications.
- Beytekin, O.F. ve Tas, S. (2017). Okul Müdürlerinin Öğretimsel Denetime İlişkin Görüşlerinin İncelenmesi. *Turkish Studies Journal*. 12(33).115-128.
- Boydak Ozan, M. ve Sener ,G. (2015). Sınıf Öğretmenlerinin Denetim Sürecine İlişkin Algı ve Beklentilerinin Metaforlar Aracılığı ile Belirlenmesi. *Eğitim Bilimleri Dergisi*. 41.19-33.
- Erdem, A.R. (2006). Öğretimin Denetiminde Yeni Bakış Açısı: "Sürekli Geliştirme" Temeline Dayalı Öğretimin Denetimi. *Selçuk Üniversitesi Sosyal Bilimler Dergisi*. 275-294.
- G. Rata, P. Luciana Runcan and H. Arslan. (2013). Applied Social Science: Educational Sciences. London: Cambridge Scholars Publishing.
- Kapusuzoglu, S. (2008). Okula dayalı yönetimde denetim sisteminin işlevselliği ve katkısının değerlendirilmesi, *Abant İzzet Baysal Üniversitesi Sosyal Bilimler Enstitüsü Dergisi*, 1(16),143-155.
- Koklu, M. (1996). Eğitim Denetimi. *Kuram ve Uygulamada Eğitim Yönetimi Dergisi* 2(2).259-268.
- Koybasi, F., Ugurlu, C.T., Bakir Agiroglu, A. ve Karakus, B. (2017). İlkokullarda Ders Denetimine İlişkin Öğretmen Görüşleri. 12 (4). 327-344.
- MEB, (2011). *Öğretmen Denetim Rehberi*. Milli Eğitim Bakanlığı Rehberlik ve Denetim Başkanlığı. Ankara.
- Memduhoglu, H.B. (2012). Öğretmen, Yönetici, Denetmen ve Öğretim Üyelerinin Görüşlerine Göre Türkiye'de Eğitim Denetimi Sorunsali. *Kuram ve Uygulamada Eğitim* 12(1). 135-156.
- Memduhoglu, H.B. ve Zengin, M. (2012). Çağdaş Eğitim Denetimi Modeli Olarak Öğretimsel Denetimin Türk Eğitim Sisteminde Uygulanabilirliği. *Kuramsal Eğitimbilim Dergisi*,5(1),131-142.
- Rata, G., Arslan, H., Runcan, P., & Akdemir, A.(2014). Interdisciplinary perspectives on social sciences. Cambridge: Cambridge Scholars Publishing.
- Yıldırım, A. ve Şimşek, H. (2008). *Sosyal Bilimlerde Nitel Araştırma Yöntemleri* (6. Baskı). Ankara: Seçkin Yayıncılık.
- Yılmaz, K. (2009). Okul Müdürlerinin Denetim Görevi. *Inonu Üniversitesi Eğitim Fakültesi Dergisi*. 10(1).19-35.
- Zepeda, S. J. (2016). Öğretim Denetimi (3. Baskı). A. Balci ve C. Apaydin, Cev., Ankara: Pegem Akademi.

# **Black Box in Turkish Education System: Prof.Dr. Adil Turkoglu's Life, Pieces and Scientific Contributions**

Sezen Sigin, Adil Adnan Ozturk

## **1. Introduction**

In respect of Turkish Education History, worthful pieces of Osman Nuri Ergin, Nafi Atif Kansu, Nevzat Ayasbeyoglu, Faik Resit Unat, Aziz Berker, Prof. Dr. Mahmut Cevat, Prof. Dr. Yahya Akyuz, Necdet Sakaoglu and Cavit Binbasioglu were published and these pieces made contributions to our education history. Within these pieces there is not enough information that analyses the pieces of directors and academicians. Cavit Binbasioglu's (2014) piece analyses the directors and academicians in Turkish Education History with their identities, professions and pieces and this piece made great contribution to Turkish Education History. Along with Prof. Dr. Erdogan Basar' Precious studying (1999) in the field of National Education Minister and Their Activities in Turkish Education History, young researchers Derya Tan (2007), Mehmet Cetin (2015), Huseyin Dumano (2010) have made contributions.

Unfortunately, there is not enough academic thesis, biographies, articles about the people making a great contribution to Turkish Education and Education History. Also many of academicians did not write their biographies and monographies. We can rarely see the people writing their biography. Prof.Dr. Adil Turkoglu is one of them.

Mubahat Kutukoglu defining the biography as the life stories of the people who are historic has stated the importance of writing a biography (Kutukoglu, 2001:23). Akalin (1984) has called the memoirs written objectively for the aim of announcing the success, pieces, lifes of famous people in the fields of art, literature, science, policy, trade as a biography. (Akalin, 1984:24) On the other hand the works based on analyses, researches, documents through critical attitude to the his/her successes, his/her innovations, his /her position in his/her period with chronological order have been called as an "academic biography" or "biografic monography" (Akalin, 1984:24). Our study belongs to the category of an academic biography.

Basis of social development is formed by acquired skills' transferring intergenerationally. (Carr, 1980:252) Therefore memoirs have a key position in transferring of the intergenerationally acquired skills and knowledge to the next generations. (Ozdemir, 1972:378) One of the reason for writing a memoir is not been forgotten and transferring the fact to the history and society (Olgun, 1972:405).

Memoirs, been written by famous artists, politicians and academicians, are very important. Since they give information about their lifes, important events in the term they lived. Memoirs have vital assistance during describing of historical facts. Although memoirs are not a history, they are an assistant to the history. Memoirs telling the characteristics of the periods are vital documentary for the people writing that period's history. In this respect Mr. Turkoglu's memoires are very important.

## **2.Method**

In our study scanning method is applied that the documents related with the subject have been analysed through scanning. Also unstructured interview technique has been used. Obtained informations have been noted as Word document. Descriptive analysis has been made with the obtained informations.

## **3. Findings and Discussion**

### **3.1. Prof. Dr. Adil Turkoglu's Life And Education**

Prof. Dr. Adil Turkoglu, was born on 20th-25th July 1949 in Karamanli town of Tefenni, Burdur (In his identity card his date of birth is 8th March 1949). In those days the people of Karamanli were engaged



in agriculture. The main source of living in Karamanli was the production of onion, wheat, barley and aniseed until 1965.

When the Democratic Party came into power with the elections of 14th May 1950 (Karpaz,2017), the changes in agricultural production were starting to become in Karamanli and Burdur as in the whole Turkey. Especially after the year 1955, tractor was being used much more in Turkish agriculture through the aids and supports from the USA. The usage of tractor and industrialization in sugar plant and weaving mill particularly ensured the changes in agricultural production. In addition to the production of onion, beet and fennel's production was increased in Karamanli in which the people were called as after the year of 1955. Commercial beet which was used in sugar production, became the most important production base and source of income of the town.

His father Veli Turkoglu being a draper was one of the leading merchants of the town. Veli Turkoglu rarely went to Istanbul for dealing and he stayed there approximately a week. In his duration of stay, he spent his time on visiting the museums and exploring the city of Istanbul except for the time he spent for his business meetings.

Veli Turkoglu told about the places and museums that he visited to his son on his return from Istanbul. This situation has largely affected Mr. Adil Turkoglu's life. Mr. Turkoglu has desired to explore new places with his father's effect and made use of the opportunities that he found. Mr. Turkoglu has always been eager to the subject of education and exploring the new places. This situation has affected his life and led him to go to France twice for education. Mr. Turkoglu was enrolled to Cumhuriyet Primary School one of the two Primary Schools which were named in honour of Cumhuriyet as "Devrim and Cumhuriyet" in town. Mr. Turkoglu had a retentive memory and improved talent of memorization. This fact was realized by his primary school teacher Mrs. Bedriye. She had him read a poem with two stanzas in Republic Day Celebrations and he became very successful. He realized his memorization talent after his success in reading a poem. This situation let him stand out the others in his education life. Mr. Turkoglu studied at his secondary school in Karamanli as a result of the thought that there should be a secondary school in every village and a high school in every city. (MEB Tebligler Dergisi, 1951:45; Milli Egitim Bakanligi Faaliyet Raporu, 1951:3) He graduated from his high school in Burdur due to the absence of a high school in his town. There were not sufficient number of high schools in a major part of Turkey until 1950's. Democratic Party opened high schools in every city through the thought of "a signature, a headmaster" (*Cirilti*, 1954) in 1950 (DIE Milli Egitim Istatistikleri Ilkogretim 1953-1960), 1963:77-78). One of those high schools opened in Democratic Party period was Burdur High School in which he graduated. It was opened in 1951(Zafer Gazetesi, 27 Eylul 1954.) (Ozturk, 1997) he enrolled in Burdur High School in 1962 and he stayed in the same house with his brother going to the same with him.

Mr. Turkoglu and his friends Bekir Ozer and Yucel Ayhan published a wall newspaper containing literature, policy and sport news in their high school times in Burdur High School.

He took some teachers as an example to himself in his high school times. His role model in the matters of cleaning, well dressing and giving a lecture was his French teacher Mr. Ibrahim. Thus Mr. Turkoglu drew attention for his clean and well dressing from his high school times to nowadays.

Mr. Turkoglu spent his much time remaining from studying on watching movies and matches. This situation gained him a vast intellectual knowledge. His biggest desire was becoming a teacher or a lawyer. He was successful at verbal lessons but he was afraid of math course. However Mr. Turkoglu graduated from his high school by overcoming his 13 years of Math fear with Kemal teacher's social and Necati teacher's authoritative skills. He took 289,6 points in university entrance examination and also he became successful in Bursa Education Institute Turkish, History, Geography and Citizenship Departments' examinations.

There seems to be the differences between the university entrance systems of today and the years when he graduated from high school. Middle East Technical University, Istanbul Technical University and Gazi Education Institute were doing separate examinations from University entrance examination. Although Mr. Turkoglu's point qualified to enter the faculty of law, he enrolled in Faculty of Educational Sciences for becoming an inspector. He completed his first class with great success and he

gained much self confidence. When he was at his second class, he saw the the announcement of Sumerbank would give a scholarship to two students passing through the first class to second class with a success and he applied to Sumerbank General Management and his application was approved.

He was paid 350 Turkish Liras for scholarship along with 800 Turkish Liras for buying two pairs of suits, shoes, underwears, a bag and a book by Sumerbank. Also he did his internship with 36 days and he gained 30 Turkish Liras Daily wage. In those days, a teacher being an officer in National Education gained 332 Turkish Liras. His economic comfort reflected to his daily life. In this meantime the political events of 1968 were started in Faculty of Education May 1968 by leadership of Celal Kargili. The boycotts starting in The Faculty of Language, History and Geography were followed by the boycotts in Faculties of Political Sciences, Law, Agriculture and Veterinary. A week after students' boycotts expanded to the higher education students in the cities of Istanbul, Izmir, Erzurum, Trabzon. The claims of the students were;

- v Changing of the examination regulation
  - v Regulating the lessons by revising them according to the term's conditions
  - v Regulating the lecturer-student relationship
- Verbal examinations should be removed.

The most part of these requests were made real. Mr. Turkoglu gaining a scholarship from Sumerbank went to Sumerbank Halkapinar Printed Fabrics Factory in Izmir for doing his internship on "Education Expertise" on his summer holiday.

He was both learning processing of cotton, becoming the form of fabric and responsible for the duty of dealing with library during his being located in Izmir Sumerbank. Mr. Turkoglu mingled with plenty of books by classifying them according to their authors' and subjects' names. He continued the same duty in Kayseri Sumerbank Printed Fabric Factory. Therefore he had a vast knowledge of literature through memorasing the thousands of books thanks to his ability of memorisation. Mr. Turkoglu's literature knowledge in library offered important opportunities to him in his next years. He became a walking library by adding academic knowledge to his literature knowledge being obtained in Sumerbank Factories. When he completed his internship, he returned to Ankara. In his third class, he elected "Educational Administration, Supervision, Planning and Economy" Department. Mr. Turkoglu was a hardworking student and his friends called him as a grind. He spent his time with watching movies in eight cinemas in Ankara and went to theatre when he was a student in Ankara. Mr. Turkoglu graduating from his school with the rank of 1st was so comfortable because of not having appointment problem. He started his duty at Sumerbank Education Directorate as soon as he graduated. However, his goal was to stay at Faculty of Education as an assistant. He went to French course for this goal. In this meantime, master and doctorate programs of Program Development, Psychological Counseling and Guidance and Department of Special Training were opened in Faculty of Education. Mr. Turkoglu entered for the Department of Program Development upon being informed by his master Prof. Dr. Fatma Varis about recruitment of an assistant to herself. Prof. Dr. Fatma Varis went to Istanbul first for applying a questionnaire to the professors and associate professors of the universities in Ankara, Izmir, Erzurum and Trabzon with her assistants for the academic study of "Postgraduate Education in Social Sciences" and Postgraduate Education in Physical Sciences in Turkey" being supported by Tubitak. Mr. Turkoglu and the other two students participated in this questionnaire application. Mrs. Varis stated that "these three of them were assistant" during her conversation in questionnaire application. Afterwards these three students including Mr. Turkoglu became an assistant on 17 March 1971. In this meantime, continuing his postgraduate education, Mr. Turkoglu's first seminar was "Faculty of Education Graduates' Inservice Problems" being published in faculty journal in 1971.

Finding of Prof. Dr. Fatma Varis was so right and fitted during his oral examination of his postgraduate education. Mrs. Varis used the term of "Photographic Apparatus" for him. It is possible to witness and see this matter either in his Daily conversations or his memories.

Mr. Turkoglu's goal was to do a doctorate after he had completed his postgraduate education. When he learnt the scholarship of French Government through State Planning Organization, he applied to it with the support of his master Mrs. Varis. He achieved the oral examination (Turkish) in French

Embassy. He went to Paris for his education on 10 August 1979. He enrolled in Sorbonne University after his language course in Lyon with one month. One of the courses that he got in this university was Comparative Education which was his area of expertise in his next years. Mr. Turkoglu started his doctorate education in 1973 upon his returning to Turkey after a year. He assumed the title of doctor by preparing a thesis about “ Comparison of the High Schools’ Programs in Turkey and France” in 1976 when he was 28 years old.

He continued his duty as a doctor assistant position due to the lacking of an assistant professor position before 1980. He had to enter into Cukurova University upon not finding a staff for himself. He went to France once again in 1979. He prepared his associate professorship thesis “ Capitalist, Social Democratic and Socialist Education Systems France, Sweden and Romania” here. He became an associate professor in May 1982. After 1980 revolution, 1982 constitution was prepared by a group led by Orhan Aldikacti (Kili, 2000 ve Tanor, 2013) and YOK was established. Thus act of YOK enacted. According to this law he couldn’t become an associate professor or a professor where he did his duty. Therefore, he applied to Cukurova University and he started his duty as an associate professor in Faculty of Education on 14 September 1984. He worked here 21 years in different positions. As Prof. Dr. Fatma Varis stated in her report that he is the first and the one in his profession. He was appointed to the professorship in February 1989 through the statement of Prof. Dr. Fatma Varis. He became a professor when he was 40 years old. He prepared the thesis of “ The Problems Encountered in Educational Academies” which was the main piece for professorship.

### **3.2. Prof. Dr. Adil Turkoglu’s Activities As A Director**

Prof. Dr. Adil Turkoglu has worked as a director for 22 years in his 44 years of academician life. His first directorate position was vice-dean of Faculty of Education in Cukurova University in which he went for being a part of an academic staff. He was appointed to this position on 14 September 1984 upon the suggestion of Dean Prof. Dr. Vural Ulku 15 days later his starting his position as an associate professor in Cukurova University. He experienced so much difficulties during his 2 years of deanship there. This situation was an important experience to him in his next directorate positions.

He was appointed to Adana Education Academy, whose goal was training students for being a class teacher, as a headmaster by Prof. Dr. Mithat Ozsan famous rector of Cukurova University on 16 September 1986. As many high schools’ and academies’ opening in Turkey, this school also had neither a class nor a desk. Mr. Turkoglu met every need of the school along with newly appointed officers Nuran and Ali. The school started its’ education term with 100 students. There came the ranks of first and second from this school’s in which Mr. Turkoglu was a headmaster, 1989-1990 graduates. This case appeared on the first page of Hurriyet newspaper with declaration of “From Hut to Turkey Championship”. Mr. Turkoglu was the first and the last headmaster of this school. The school was closed after a short time. Mr. Turkoglu became a professor in 1989. Turkoglu lost tendency survey with just one vote after the Faculty of Education dean Prof. Dr. Vural Ulku’s completing his second deanship term. He accepted the proposal of Prof. Dr. Vural Ulku for being vice-dean.

On the other hand, 21 new universities were opened in 1992 by YOK (Kavili Arap, 2010; Gunay&Durupcu, 2015). Mersin University was one of those that were newly opened. Prof. Dr. Vural Ulku was appointed as a rector to Mersin University. Mr. Turkoglu got 22 and his rival got 3 votes in tendency survey for Cukurova University The Faculty of Education Deanship after Mr. Ulku’s leaving. He was appointed to the Faculty of Education Deanship on 31 Aralik 1992 by rector Mr. Ozsahinoglu. Mr. Turkoglu’s first action was focusing on environmental cleaning and making the tea house more functional by regulating it as in Adnan Menderes University The Faculty of Education afterwards. Mr. Turkoglu provided for planting 1000 trees to school via his motto that “Every student has a tree”. He was always supported by Prof. Dr. Can Ozsahinoglu becoming a rector after Prof. Dr. Mithat Ozsan. In this meantime, large part of the problem of academic staff in faculty was solved and additional building construction was started.

Mr. Turkoglu stood as a candidate for deanship when his deanship term finished in 1995 and he was appointed as a dean once again by the rector with gaining 41 votes of academicians out of 42

academicians. After his deanship election, he executed Educational Sciences Symposium for the first time with the supports of Prof. Dr. Can Ozsahinoglu rector of Cukurova University. This symposium's being started in Cukurova University for the first time, 27th turn will be held at Erzurum Ataturk University in 2018.

He did not want to become a dean again upon his duty's ending. However, he was appointed as a dean again as a result of common consensus upon the candidate lacking. Learning to solve many problems in his deanship periods, Mr. Turkoglu especially spent his much time on two subjects. One was about the staff and the other one was the problem of belongings in academicians' and officers' rooms. The belongings problem was solved easily through the formation income in Cukurova University's the Faculty of Education.

Mr. Turkoglu stated that it would be necessary to put an elective course about "not get carried away" in schools. Mr. Turkoglu became a candidate for the elections of rector voluntarily with his social environment in 2000. Although his becoming a rector seemed certain based on the previous tendency surveys, he experienced the loss of 60 votes due to a group's changing their mind suddenly. This situation led to his loss of election. After this election, he continued to his rest 18 month duty of deanship. Afterwards, he lost the deanship election against Prof. Dr. Necmi Yasar a vice-dean of him previously being supported by the rector indirectly in 2004. In this election Mr. Turkoglu got 27 and Mr. Yasar got 32 votes. (The interview with Turkoglu, 14.12.2017 Thursday).

It was a mistake for being a candidate to deanship after his rector candidateship just as his stating in his own memories. He got tired of Adana and Cukurova University as a result of his loss of rector candidateship. He desired for the universities in Antalya, Izmir and Istanbul. However, he got proposal from Adnan Menderes University Faculty of Education. Before him Aydin Adnan Menderes University The faculty of Education dean was Prof. Dr. Muharrem Sen whose staff was at Faculty of Science and Letters. In the meantime Prof. Dr. Sukru Boylu from The Faculty of Medicine won the election of rectorship and he was appointed. While Prof. Dr. Seda Saracoglu's the head of Educational Sciences Department, appointment as a dean was being expected, Mr. Turkoglu was appointed as a dean to Adnan Menderes University The Faculty of Education upon the request of rector Mr. Boylu in 2007. Mr. Turkoglu firstly provided for the arrangement of class and conference room during his deanship. He arrayed the tea house and toilets once again as his action at Cukurova University. Prof. Dr. Mustafa Birincioglu having 3rd rank was appointed as a rector instead of Prof. Dr. Sukru Boylu having 1st rank in the election of rectorship in 2010.

Mr. Turkoglu continued his administrative duty as an agent dean. He left from his duty upon Prof. Dr. Seda Saracoglu's being both vice rector and agent dean in 2010. He continued his duty of the Head of Educational Sciences Department until he got retired due to the age factor.

#### **4. The Main Problems that Prof. Dr. Adil Turkoglu Faced in Turkish Education System**

The problems in Turkish Education System that Mr. Turkoglu faced both his being a student and his being an academicians periods are as below; beating in schools, efficiency, lacking of an environment for studying, many youth's not going secondary education due to the economic problems (there is not any high school in town), strict discipline punishments being implemented in schools, inadequate material for sport in schools and sports not being supported, teachers' not knowing human relations well and their inability to making a contact with the students, cleaning, inadequate tools and equipment for lesson, every teacher's caring about their own lesson and their disregarding the other lessons, the problem of nourishment

#### **5. The Books of Prof. Dr. Adil Turkoglu**

The books of Mr. Turkoglu were as below; Homework at Primary Education (Turkoglu, 2004), Entering into the Teaching Profession with 109 Questions (Turkoglu,2005), The techniques of Studying and Learning for Success in School (Turkoglu, 2009), From Village Institutes to Urban Institutes: A Model Proposal (Turkoglu, 2011), A Comparative Education with Examples from World Countries (Turkoglu,

2016), The books of From Village Institutes to Urban Institutes: A Model Proposal, A Comparative Education with Examples from World Countries should be seen different within these books.

### **5.1. From Village Institutes to Urban Institutes: A Model Proposal**

This study proposes an “Urban Institutes” model for finding a solution to the problems of urbanised Turkey. This model is a suggestion. It is an argumentative, open to criticism and deficient. The deficiencies can be solved during the implementation phase. If the other academicians completed the model containing the writer’s 20 years of thought, this case would lead to a great happiness.

### **5.2. Comparative Education**

Comparative education is a branch that analyses the national education systems by taking political, social and cultural factors into consideration and discusses the meaning of primary and secondary education. (UNESCO, World Survey Of Education, 1955) As regard to Mr. Turkoglu, it is a discipline that assists for describing the similarities and differences of the two or more education systems in different countries and cultures and brings useful suggestions about the methods of people’s education. (Erdogan, 2006:97)

Comparative Education proceeded to progress as an education discipline in 1990s (Erdogan, 2006:98). Comparative education got into the academical framework after 1960s. It is possible to see few examples of this field in 10th and 11th centuries at Turkish education history. (Bilhan,1992)

Regarding to Erdogan (2006), there were 44 articles, 17 books for this field in Turkey until 2006. Turkoglu’s 2 articles (Turkoglu, 1983a, 1983b) and 2 books (Turkoglu, 1983, Turkoglu, 1984) are found within these 44 articles. Although many academicians notably Kemal Aytas (Cagdas Egitim Akimlari 1976) made researches in this field, there are few known academicians as “Comparative Educationist” nowadays (Erdogan; 2006). One of those is Prof. Dr. Adil Turkoglu.

Writing process of the book was started on November 1979 and completed on March 1982. It was acknowledged as associate professorship thesis and published in 1983. The book consists of 3 chapters. In the first chapter, the problem is set forth and the applied method is told, in the second chapter the evolution of French, Swedish and Romanian Education Systems is explained then the education systems are discussed with regard to these factors; I. Goals of Education, II. Basic Principles and Legal Foundations, III. The roles of Central- Local Governments, IV. Planning of Education and Finance. In the third chapter, it is consisted of result and suggestions (Turkoglu, 1983:4). Every country develops and practices an education system which is suitable for her political regime’s principles. These three countries have different political regimes from each other.

According to the author, French education system’s impact on our education system, Sweden’s being pilot country and Romania’s applying a socialist education system are characteristics which should be known and searched by us (Turkoglu, 1983:5).

### **5.3. The Dissertations Directed by Prof. Dr. Adil Turkoglu**

Adil Turkoglu directed 45 total thesis as thesis supervisor of master and doctorate programs. Mr. Turkoglu directed 23 master thesis. He directed 12 of those 23 thesis between the dates of 1988-2007 at Cukurova University, 8 of those 23 thesis between the dates of 2007-2010 at Adnan Menderes University and one of those 23 thesis in 2011 at Dokuz Eylul University. When we look at the thesis directed by him, we can see the subjects of primary and secondary education programmes, academic successes, programme reviews, reinforcers, syllabuses and learning issues based on the problem.

Turkoglu directed 20 doctorate thesis. He directed 10 of those 20 thesis between the years of 1988-2006 at Cukurova University and one of those 20 thesis in 2010 at Adnan Menderes University. The subjects of his doctorate thesis are foreign language education, text reading and comprehension, knowledge mappings, teacher training programs, teacher behaviours, teacher’s professional attitudes.

## 6. Result

Adil Turkoglu's contributions to Turkish Education are important. He wrote 7 books in his active professional life of 44 years. Some of these books are published more than one. From Village Institutes to Urban Institutes: A Modal Proposal book within his 7 books was taken as an example by many people and institutions notably Eskisehir and Aydin Municipalities.

The other important study of Mr. Turkoglu is his associate professorship thesis published in 1983 and named as A Comparative Research (Ankara: Ankara Universitesi Egitim Bilimleri Fakultesi Yayinlari No: 121, Ekim 1983). In his study, he compares the French, Swedish and Romanian education systems. He is one of the preeminent academicians in the field of comparative education. Symposium on Educational Sciences' pioneered by him during his being the dean of Faculty of Education in Cukurova University, 27th will be held in 2018. Hundreds of declarations presented in these symposiums were put into article and shed light on Turkish science and education life. Also he made an impression of hardworking academican through his articles, speeches and declarations in various organisations.

## 7. References

- Adil Adnan Ozturk (1997), *Turkiye'de Milli Egitim'deki Gelismeler (1950-1960)*, Izmir: Dokuz Eylul Universitesi Ataturk İlkeleri ve Inkilap Tarihi Enstitusu Yayimlanmamis Doktora Tezi.
- Adil Turkoglu (2005), *109 Soruda Ogretmenlik Meslek Bilgisine Giris*, Kare Yayinlari, Istanbul.
- Adil Turkoglu (2011), *Koy Enstitulerinden Kent Enstitulerine Bir Model Onerisi*, Ani Yayıncılık, Ankara.
- Adil Turkoglu (2014), *Egitim Surecinde Odev*, Ani Yayıncılık, Ankara.
- Adil Turkoglu (2016), *Karsilastirmali Egitim, Dunya Ulkelerinden Ornekler*, Ani Yayıncılık, Ankara.
- Adil Turkoglu ile yapılan gorusme, 14.12.2017.
- Asli Gunay, Murat Ali Durupcu (2015), *Turkiye'de 1992 Yilinda Kurulan Devlet Universitelerinin Stratejik Planlarinin Karsilastirmali Bir Analizi*, *Yuksekk Ogretim ve Bilim Dergisi*, Cilt 5, Numara 3, Aralik 2015.
- Bulent Tanor (2013), *iki Anayasa, 1961 ve 1982*.
- Ceyhan Eyupoglu, Seker Fabrikasyonun Tarihcesi ve Turkiye'de Seker Sanayii, [http://www.kmo.org.tr/resimler/ekler/c5713d135d7635b\\_ek.pdf?dergi=38](http://www.kmo.org.tr/resimler/ekler/c5713d135d7635b_ek.pdf?dergi=38) (Erisim Tarihi: 16.12.2017)
- "Celal Yardimci'nin Yeni Ogretimi Acis Konusmasi" *Zafer Gazetesi*, 27 Eylul 1954.
- Derya Tan (2007), "Milli Egitim Bakanlari ve Egitim Icraatları" (1980-1999), Adnan Menderes Universitesi, Sosyal Bilimler Enstitusu, Yayinlanmamis Yuksek Lisans tezi.
- DIE Milli Egitim Istatistikleri (1963), (Ilkogretim 1953-1960), Ankara.
- Emel Aslan (2014), *Turkiye'nin Ic Siyasetinde Demokrat Parti (1950-1960)*, Ahi Evran Universitesi, Sosyal Bilimler Enstitusu, Yayimlanmamis Yuksek Lisans Tezi.
- E. H. Carr (1980), *Tarih Nedir?*, Birikim Yay., Istanbul.
- Emin Ozdemir (1972), "Ani ve Ani Dilimiz Uzerine", *Turk Dili*, XXV/246.
- Huseyin Dumano (2010) "Prof. Dr. Fatma Varis: Yasami ve Eserleri" Adnan Menderes Universitesi, Sosyal Bilimler Enstitusu, Yayinlanmamis Yuksek Lisans Tezi.
- H. Husnu Cirilti (1954), *Ortaogretim Muammasi* Yeni Okul, Cilt: III, Sayi: 84.
- Ibrahim Olgun (1972), "Ani Turu ve Turk Edebiyatinda Ani", *Turk Dili*, XXV/246.
- Bulent Karpaz (2017), *Turk Demokrasi Tarihi*, Sosyal, Kulturel, Ekonomik Temeller, Ankara.
- Mehmet Cetin (2015), "Milli Egitim Bakanlari ve Egitim Icraatları" (1999-2011) Adnan Menderes Universitesi, Sosyal Bilimler Enstitusu, Yayinlanmamis Yuksek Lisans Tezi.
- MEB Tebligler Dergisi (1951), Cilt 14, Sayi 649.
- Milli Egitim Bakanligi Faaliyet Raporu (1951), Ankara: MEB Yayini.
- Mubahat Kutukoglu (2001), *Tarih Arastirmalarinda Usul*, Kubbealti Nesriyat, Istanbul.
- Sami Akalin (1984), *Edebiyat Terimleri Sozlugu*, MEB Yay., Istanbul.
- Suna Kili (2000), *Turk Anayasa Metinleri, Sened-i Ittifaktan Gunumuze*, Istanbul.

Sultan Kavili Arap (2010), Turkiye Yeni Universitelerine Kavusurken: Turkiye'de Yeni Universiteler ve Kurulus Gerekceleri, Ankara Universitesi, SBF Dergisi, 65-1.

Taylan Kiyamaz (2002), Seker Politikalarinda Yeni Yonelimler ve Turkiye'nin Konumu, Ankara.  
UNESCO (1955), World Survey Of Education.

# Comparison Of 2004 And 2017 Social Study Programs

Burcu Karademir, Adil Adnan Ozturk

## 1. Introduction

Primary education, the first step of the education system, is where children gain social knowledge and skills. This period when the attitudes of the child develop, as well as social behavior, family life, close relationships. The information obtained during this period affects the future life of the child (Akdag, 2014). Primary education is a period of education that should be meticulously focused on within the education system.

The Social Studies term is used to indicate the program containing the units based on the content from the social sciences (Saglam, 1980). Social Studies is a civic education program aiming to integrate the findings of the social sciences and simplify them according to the level of the learners and to use them to gain the knowledge, skills, attitudes and values that students need to adapt to social life and to solve social problems (Ozturk, Otluglu, 2003).

The primary purpose of Social Information is to help improve people's ability to make informed and logical decisions in a democratic society with cultural differences in a mutually interconnected world (Akt. Ozturk, 2007). One of the inferences made for Social Studies is the society. In terms of social studies, society is to provide socialization in the community where the individual or the student lives. The social expectancy of the society is to raise qualified generations to ensure its continuity (Akdag, 2014).

Environmental conditions should also be taken into account in teaching social studies. Everything about the individual's life can be shaped by the social and physical environment in which he lives. In primary education; Life Science in 1.2.3 grades; Social Studies in 4, 5, 6, 7 grades; Atatürk's Principles and History of Revolution are taught in the 8th grade are taught. These lessons are a training program that produces appropriate objectives for the responsibilities of the citizens of Turkish democratic society and combines the content of history, geography and citizenship knowledge and envisages the implementation of lifelong citizenship skills (YOK-World Bank, 1996).

According to the Regulation of primary education institutions M.E.B published in Turkey in 1997, one of the goals of elementary schools in HRM; "Educating students as good and happy citizens who play their roles in society, establish good relations with others, work in cooperation, adapt to their environment". In view of the expressions in this aim, it is aimed the student as educational behavior in terms of skill and value as well as educating him / her as a sample individual in terms of socialization. This lesson is undoubtedly a social science course. Social Studies also emphasizes the three traditions that Barr, Barth and Shermis (1977) put forward. As it is known, these are: social studies as a transfer of citizenship, social studies as Social Sciences, social studies as Reflective Thinking.

Within the framework of approaches in the teaching of social studies, certain characteristics such as certain knowledge, skills, values, active learning and social participation are evolving. These characteristics that are expected to develop are: relationship with people, tolerance, international understanding, coping with change, personality development, peace, national and cultural values, economic efficiency, citizenship and human rights (Akt. Paykoc, 1995).

In the lesson, while students learn about the past and present of the society they live in, they also learn about other societies. Such a comprehensive content gives them the opportunity to recognize the rich and cultural experience that humanity has created since centuries (Ozturk and Otluglu, 2003). One of the main elements that make up an education system is the curriculum. Therefore, reforms in education should be mainly on curricula. Each curriculum is based on an educational philosophy.

There have been numerous innovations and regulations in the field of education in Turkey. These are the changes made in 1924, 1926, 1936, 1948, 1968 and 1985-1988. In addition to these dates,



especially in 1992 and 1998. 8-year education has been compulsory with the regulation of the program. History, Geography and Citizenship lessons in the Republican period were merged under the name of "Society and Country Investigations" in an interdisciplinary approach in the Primary School Program Draft published in 1962 and this course was named "Social Studies" in 1968 (Gunden, 1995; Gungordu, 2002, Gokkaya, 2003, Ozturk and Otluglu, 2003, Sonmez, 2005, Tay, 2011). National Education Development Project has been prepared by the Higher Education Institution-World Bank between 1994-1997. Especially in 1996 under the title of Primary School Social Studies Teaching Edition, James L. Barth and Abdullah Demirtas also created a reference work. In this work, the universal definition of Social Studies was "Integration of discipline for the purpose of providing citizenship education in other fields such as social studies, philosophy and religion" (YOK-World Bank, 1996: 1-8). The program, which was adopted in 1998, was abolished in 2004 and 2004 programme was put into effect. The program prepared by the Social Information Specialization Commission is based on a Constructivist approach. The 2004 program was amended and the 2017 program was adopted and implemented in the 2017-2018 academic year.

## 2. Purpose of the research

The purpose of this study is to compare the understanding and learning of the 4th grade social studies curriculum of 2004 and 2017 in terms of learning areas, units, achievements, teaching hours, skills, to try to reveal the possible causes. For this purpose, the following sub-problems will be sought.

- How are the understandings in the social studies curriculum of 2004 and 2017 handled?
- How is it in the learning area and units in the 2004 social studies curriculum?
- How is the change in the learning field and units in the 2017 social studies curriculum?
- How does the number of acquisitions vary according to the areas of social studies curricula in 2004 and 2017?
- How does the course time in the 2004 and 2017 social studies curriculum change?
- How are the skills, values in the social studies curriculum of 2004 and 2017 handled?
- What are the common and different aspects of basic skills in social studies curricula in 2004 and 2017?

## 3. Method

### 3.1. Model of your research

The document review method was applied based on the qualitative research approach in the research. The document review includes an analysis of written materials that contain information about the facts and events targeted for investigation.

Documents are information sources that must be used effectively in qualitative research. In such studies, the researcher may obtain the data without the need for observation or interview (Yildirim and Simsek, 2008).

### 3.2. Source of Data

As the data source of the research, Social Sciences Lesson of the 4th-5th grade and Social Studies lesson of the 4th, 5th, 6th, 7th and 7th grade of Social Studies course by the Ministry of National Education (MEB, 2004, MEB, 2017). In this context, Social Studies curriculum for 4-5-6-7th grades, teacher's book and course books at Ankara Ferit Ragıp Tuncor Library and at the website of Ministry of National Education Board of Education and Discipline have been studied (<http://ttkb.meb.gov.tr>). Percentage analyzes have also been done in the comparative analyzes.

#### 4. Results

##### Understanding of programs in 2004 and 2017

**Table 1.** Understanding in 2004 and 2017 Programs

2004	2017
<b>Social Studies as Social Science Social as Reflective Thinking</b>	<b>Social Studies as Social Science Social as Reflective Thinking</b>

As seen in Table 1, when the learning-teaching processes of the curricula are examined, it is seen that both curricula adopt the concept of "social as Social Sciences" and "social as Reflective Thinking".

##### Learning areas in 2004 and 2017 programs

**Table 2.** Learning Areas in 2004 and 2017 Programs

2004	2017
Individual and Identity	Individual and Society
Culture and Heritage	Culture and Heritage
People, Places and Environment	People, Places and Environment
Production, Distribution and Consumption	Production, Distribution and Consumption
Science, Technology and Society	Science, Technology and Society
Groups, Institutions and Social Organizations	-
Power, Management and Society	-
Global Connections	Active Citizenship Global Connections

As shown in Table 2, there are 8 learning areas in the 2004 program, 7 learning areas in the 2017 program, the name of the "Individual and Identity" learning field in the 2004 program was changed to "Individual and Society". "Groups, Institutions and Social Organizations" and "Power, Management and Society" learning areas are not in the program of 2017 and instead a new learning area is placed under the name "Active Citizenship".

##### Programs in 2004 and 2017

**Table 3.** Units in 2004 and 2017 Programs

2004	2017
Everyone Has an Identity	-
I'm learning my past	-
Where We Live	-
From Production to Consumption	-
Good	-
All together	-
People & Management	-
My Remote Friends	-

As it is seen in Table 3, it is seen that there are 8 units in the 2004 program and no unit in the 2017 program. In the 2017 program, learning areas have been written instead of units.

### Learning gains in 2004 and 2017 programs

**Table 4.** Learning gains for 2004 and 2017 Programs

2004	2017
46	34

As you can see in Table 4, there are 46 acquisitions in the 2004 program and 34 acquisitions in the 2017 program. It is seen that the gains in the 2017 program have been reduced by approximately 26%.

### Course hours in 2004 and 2017 programs

**Table 5.** Course Hours in 2004 and 2017 Programs

2004	2017
108	108

As shown in Table 5, there are 108 lesson hours in both programs. No changes were made upon class hours.

### Skills in 2004 and 2017 programs

**Table 6.** Skills in 2004 and 2017 Programs

2004	2017
Critical Thinking	Research
Creative Thinking	Environmental Literacy
Communication and Empathy	Perception of Change and Continuity
Research	Digital Literacy
Problem solving	Critical Thinking
To decide	Empathy
Using Information Technologies	Financial Literacy
entrepreneurship	entrepreneurship
Using Turkish language correctly and effectively	Observation
Observation	Map literacy
Detecting Spaces	Communication
Perception of Time and Chronology	Cooperation
Perception of Change and Continuity	Reslising Mold Judgment and
Social Participation	Prejudice
	Using Evidence
	Deciding
	Location Analysis
	Media Literacy
	Detecting Spaces
	Self-control
	Political Literacy
	Problem solving
	Social Participation
	Drawing and Interpreting Table, Graph, Diagram
	Using Turkish language correctly and effectively
	Innovative Thinking
	Perception of Time and Chronology
14	26

## Comparison Of 2004 And 2017 Social Study Programs

As Table 6 shows, there are 14 skills in the 2004 program and 26 skills in the 2017 program. It is observed that the skills in the 2017 program have increased by approximately 86%. The 11 programs in the 2004 program have been included in the 2017 program and 13 new skills have been included in the program instead of the "Creative Thinking" and "Using Information Technology" skills and "Communication and Empathy" skill was discussed separately in the 2017 program of "Communication and Empathy".

### Values in 2004 and 2017 programs

**Table 7.** Values in 2004 and 2017 Programs

2004	2017
Fairness	Justice
Griving Importance to the Family Association	Griving Importance to the Family Association
Independence	Independence
Scientific	Peace
Diligence	Scientific
Solidarity	Diligence
Sensitivity	Freedom
Honesty	Solidarity
Aesthetic	Sensitivity
Tolerance	Honesty
Hospitality	Aesthetic
Griving Importance to be Healthy	Equality
Respect	Respect
Love	Love
Responsibility	Responsibility
Cleaning	Saving
Patriotism	Patriotism
Helpfulness	Helpfulness
<b>18</b>	<b>18</b>

As shown in Table 7, the value of both programs is 18, the 14 values in the 2004 program are included in the 2017 program, and the values of "tolerance, hospitality, cleanliness and being healthy" are removed, instead values of "equality, peace, saving and freedom" are added.

### 5. Conclusion And Discussion

The Content of 2004 and 2017 programs; insights, learning domains, units, acquisitions, periods at school, existence of skills and values, and how they are involved, are studied relatively. When the insights of the 2004 and 2017 curricula were studied, it was determined that both curricula adopted the mentalities "Social Studies as Social Science" and "Social Studies as Reflective Thinking".

In the Social Studies curriculum of 2004, it can be seen that 8 learning domains took place at the 4th grade level. These are listed as: Individual and Identity, Culture and Heritage, People, Places and Environment, Production, Distribution and Consumption, Science, Technology and Society, Groups, Institutions and Social Organizations, Power, Management and Society, Global Connections. At the 4th grade, 8 learning areas were formed as 8 units. These units are planned in order as "Everyone has an Identity", "I'm Learning My Past", "The Place We Live", "From Production to Consumption", "It is Good to Have It", "All Together", "People and Management", "My Remote Friends". It has been found that there are no units in the 2017 social studies curriculum, instead, the names of 7 learning areas have been written. In the curriculum of 2017, six of the learning domains of 2004 were taken as the same, which are "Individual and Society", "Culture and Heritage", "People, Places and Environments", "Production, Distribution and Consumption", "Science", "Technology and Society" and "Global Connections". The learning domains "Groups, Institutions and Social Organizations" and "Power, Management and Society" are not included in 2017 curriculum; these two learning fields are merged

and replaced by a new learning domain called "Effective Citizenship". With this learning area, it is expected that students should be aware of their rights as a child, take responsibilities of the words and actions of their family and school life, recommend educational social activities they consider as necessary in school life and explain the relationship between their national independence and individual freedom.

While there were 46 acquisitions in the 2004 curriculum, it is seen that there are 34 acquisitions in the 2017 curriculum, approximately with %26 reductions in the 2017 program. According to the acquisitions that are removed in the learning domains, it is understood from the change made in the learning domain from "Individual and Identity" of the 2004 program to "Individual and Society" of 2017 program that the individual is asked to put themselves in place of others rather than their own feelings and thoughts. In the "Culture and Heritage" learning domain of the 2004 curriculum, acquisition number (6) as "He/She realizes the role of Ataturk in the achievement of the National Struggle and the Declaration of the Republic" is replaced in the 2017 curriculum as "Departing from the lives of the heroes of National Struggle, he/she realizes the importance of the National Struggle", acquisition number (4). The role of Ataturk was removed and a general expression as "the National Struggle heroes" was used. The acquisitions (2,3) on the usage of figures and diagrams in the 2004 program in the domain of "People, Places and Environments" were removed from the 2017 program. In the learning domain "Production, Distribution and Consumption" of 2004, the acquisition number (7) "He/She associates jobs with needs" was removed from 2017 curriculum and put the acquisition (5) "He/She uses resources in the periphery without wasting them" instead. Thus it can be said that the newly introduced "importance of saving" is underlined in 2017 curriculum. Acquisition number (2) as "He/She recognizes the major time measuring instruments and methods used by mankind" which take place in the learning domain of "Science, Technology and Society" of 2004 curriculum was removed from 2017 curriculum and acquisition number (2) "He/She explores the inventors of the technological products they use, and the development of these products over time" was added instead. Here students are encouraged to research departing from the idea of perceiving Social Sciences as Social Studies and Social Sciences as Reflective Thinking. Apart from the acquisition (5) in the learning domain "the groups, institutions and social organizations" of 2004 curriculum as "He/She recommends educational-social activities that he/she considers being necessary in school life", it can be seen that the acquisitions (1,2,3,4) related to social organizations, official institutions and groups and other acquisitions (1,2,3,4) related to local administrations in the learning domain "Power, Management and Society" has been excluded and replaced with the combination of these two into a learning domain "Effective Citizenship". In this learning domain, students are asked to realize their rights as children, to take the responsibility of the words and actions in their family and school life, to recommend the educational-social activities that they consider as being necessary and to explain the relationship between the national independence and individual freedom (Acquisitions 1,2,3,4). In this domain of learning, it is seen that the new value of freedom in 2017 program is emphasized. Acquisitions that take place in the learning domain "Global Connections" in 2004, "he/she takes advantage of the visual materials and makes inferences about the daily lives of various communities in their daily lives." (2) and "gives examples to the special days that are accepted by various communities" (4) are seen to be removed from 2017 curriculum and acquisition (2) "He/She understands the relationships between Turkey and its adjacent countries and other Turkish Republics" and acquisition (4) "He/She respects other different cultures" are added. When we compare the 2004 and 2017 programs in terms of school periods, it is seen that there are 108 class hours in both programs and no changes are made during the class period duration.

Skill can be defined as the ability of students to acquire, develop, and the thing to be transferred to life in the learning process. Curriculums are also aimed at providing students with skills. When we compare the 2004 and 2017 programs in terms of skills, it is seen that there are 14 skills in the 2004 program, and 26 skills in the 2017 program, thus, about a 86% increase in the number of skills can be seen in the 2017 program.

It is seen that the 13 programs of 2004 curriculum are present in 2017, "Communication and Empathy" skill is studied separately, 13 skills are included in the curriculum instead of the skills

## Comparison Of 2004 And 2017 Social Study Programs

"Creative Thinking" and "Using Information Technology". These skills are; detecting preconception and prejudice, financial literacy, cooperation, usage of evidence, self-inspection, political literacy, drawing and interpreting charts and diagrams, map literacy, innovative thinking, media literacy, environmental literacy and digital literacy.

It is necessary for teachers and students to be able to use information technology at a certain level due to the transition to FATİH (Action for Increasing Opportunities and Technological Improvement in Education) Project and the use of EBA (Education, Information Network) portal. It is thought that the skill "to use information technologies" that is removed from the 2017 program, has been extended to media literacy and digital literacy skills in order to catch up with today's technology and to use technology in education. It is believed that these skills can reduce the limitations and deficiencies of the 2004 curriculum of Social Sciences aimed at educating effective citizens.

The "Creative Thinking" skill in the 2004 program was replaced with the "Innovative Thinking" skill in the 2017 program. Innovative thinking involves originality; It requires creativity. Creative thinking is defined as an association of observations, knowledge and ideas, which are acquired through knowledge and experience, to produce new ideas and concepts (Can Yasar, 2009). Thus, creative thinking also includes innovative thinking. Therefore, it can be said that the innovative thinking in the 2017 program does not satisfy the creative thinking of the 2004 program.

Although the origin of the literacy concept does only refer to the ability to read and write, the scope of the usage of this concept has expanded after the industrial revolution. After the industrial revolution, this concept is used to mean having a good education or a broad knowledge in a particular field (McBride, 2011: 23). According to Kellner (2002), literacy is the means by which the world can be understood.

Another skill that attracts attention by entering the 2017 program is "Political Literacy". An individual with political literacy skills has the ability to understand the point of view of others, to recognize their influence and to respond morally to them (Fyfe, 2007). In the new learning domain "Effective Citizenship" of 2017 curriculum, students are expected to understand the existence of an organized state power being the most important insurance of social problems, become aware of how the problems are solved and how the order is sustained, realize how the individual rights are protected in governments that are based on sovereignty by people, and conceive which democratic ways are present to affect the government. It can be said that it is tried to gain political literacy skills with effective citizenship learning domain.

One of the newcoming skills to the 2017 program is "Environmental Literacy". If an environmental literate is a responsible and sensitive citizen towards an his/her environment, the duty and responsibility of raising a citizen with such characteristics is firstly given to the social studies course in primary education courses (Karatekin, 2013). With environmental literacy skills, it is desired to educate individuals who are sensitive to the environment, give importance to recycling and use energy resources consciously.

Map literacy is the ability to use maps and understand maps in everyday life. Weeden (1997: 169) Map skills are listed as using maps, making maps, reading maps and interpreting maps. With the skill of "Map Literacy" in the 2017 program, in the learning domain "People, places and environments", students are expected to examine political and physical maps with the acquisition (5) "Make implications about the geographical features of the place where they live".

Value can be defined as a common idea, purpose, basic moral principle or beliefs that a social group or society deems to be true and necessary by a majority of its members in order to provide and maintain its own existence, unity, function and continuity. In the 2004 program, values were tried to be transmitted by traditional suggestion method, value explanation approach, moral reasoning and value analysis approach. When we look at the 2017 program, values are presented in accordance with the nature of the course within acquisitions, and students are made to feel and experience values implicitly. The teachers are expected to present the things that are both good and right by becoming a model to the students and through activities.

It has been seen that 14 values in the 2004 program are included in the 2017 program and that values such as "tolerance, hospitality, cleanliness and being healthy" have been removed and "equity, peace, freedom, savings" have been introduced instead. With the new values of "equality, peace and freedom" that entered the 2017 program are thought to be the cornerstones that defines the future of a nation, which faced a coup attempt against the government on July 15, 2016, and future generations are demanded to understand that without democracy and freedom, a nation can not exist and is open to both internal and external threats.

In the "Culture and Heritage" learning domain, a general expression as "the National Struggle heroes" was used in the 2017 program by removing the acquisition (6) "He/She realizes the the role of Atatürk in achievement of the National Struggle and in the declaration of the Republic" that take place in the 2004 curriculum. It is considered to be wrong to omit the role of Atatürk, who has the greatest importance in the foundation of this country and the republic, during the National struggle from the curriculum. It is suggested that for giving the importance and value that Atatürk deserves, the acquisition should be reincluded in the curriculum as "He/She understands the importance of the National Struggle and Turkish Republic by studying the lives of both Mustafa Kemal Atatürk and the heroes of the National Struggle". Another value that has just entered the 2017 program is "Saving". We can define saving as careful behavior in consumption and usage of the materials, which are indispensable, and are required for the existence of life for both humans and other living beings, in their most economical level and at their basic amounts. This value is first given in the family. Family members can create a table of income and expenditure based on a sample budget and make students aware of the needs and demands of them, and thus this acquisition can be given to the students. For this reason, it is thought that in the 2017 program, students are demanded to use the limited resources for the country's economy and the future of the world carefully and consciously and to be provident.

The removing of tolerance and hospitality, which were present in the previous program, from the 2017 program is considered as a mistake. It can be said that hospitality and tolerance are among the most beautiful characteristics of Turkish society. Our country's approach to Syrian refugees, which meets the needs of many millions of Syrians who have fled from the internal war in their countries, such as shelter, health, education, clothing and food, is a good example of how welcoming and tolerant Turkish society is. It may be suggested that these values, which distinguish us from the other societies that identifies us should be revised and added to the future program.

It was determined that the acquisitions in the 2017 program were reduced compared to the 2004 program. The reason for this can be the excessive number of acquisitions to be given to the students. In this context, it is advisable to determine how much of the 2017 acquisitions are achieved to shed light on the future curriculum.

## 6. References

- Akdag, H. (2014). *Sosyal Bilgilerin Tanımı, Amacı, Önemi ve Türkiye'deki Yeri*. Turan, R., Sunbul, A. M. ve Akdag, H.(Ed.).Sosyal Bilgiler Öğretiminde Yeni Yaklaşımlar I. Ankara: Pegem Akademi Yayıncılık.
- Barr,R., Barth J.L. ve Shermis S.S. (2013). *Sosyal Bilgilerin Doğası*. Ankara: Pegem Akademi Yayıncılık.
- Barth, J. ve Demirtas, A. (1997). *İlköğretim Sosyal Bilgiler Öğretimi*. Ankara: YOK/Dunya Bankası Yay.
- Can Yasar, M. (2009). *Anasınıfına devam eden altı yaş çocuklarının yaratıcı düşünme becerilerine drama eğitiminin etkisinin incelenmesi*. Yayınlanmamış Doktora Tezi, Ankara Üniversitesi, Ankara.
- Fyfe, I., (2007) *Hidden in the curriculum: Political Literacy and Education for Citizenship in Australia* *Melbourne Journal of Politics*, Vol. 32, pp. 110-134
- Gunden, S. (1995). *Sosyal bilgiler öğretimine genel bir bakış. İlköğretim okullarında sosyal bilgiler öğretimi ve sorunları*. Ankara: T.E.D. Öğretim Dizisi No:13. (Haz. Meral CİLELİ).
- Gungordu, E. (2002). *İlköğretimde hayat bilgisi ve sosyal bilgiler öğretimi*. Ankara: Nobel Yayıncılık.

## Comparison Of 2004 And 2017 Social Study Programs

- Gokkaya, K. (2003). Sosyal bilgilere giriş. *Icinde Konu alanı ders kitabı inceleme kılavuzu sosyal bilgiler*. Sahin C. (Ed.). Ankara: Gunduz Egitim ve Yayıncılık, ss. 9–29.
- Karatekin, K., (2013) *Cevre okuryazarlığı*. Ebru Gencturk, E. ve Karatekin, K. (Ed.). Sosyal Bilgiler İcin Çoklu Okuryazarlık. Ankara: Pegem Yayıncılık.
- Mcbride, B. (2011). *Essential elements of ecological literacy and the pathways to achieveit: perspectives of ecologists*, Unpublished Doctoral Dissertation, The University of Montana, Missoula.
- MEB, (2005). *Sosyal bilgiler 4.-5. sınıf programı*. Ankara: Devlet Kitapları Mudurluğu Basımevi
- MEB, (2017). *Sosyal bilgiler dersi öğretim programı (İlkokul ve Ortaokul 4, 5, 6 ve 7. Sınıflar)*. <http://ttkb.meb.gov.tr> adresinden 04.09.2017 tarihinde alınmıştır.
- Sonmez, V. (2005). *Hayat ve sosyal bilgiler öğretimi ve öğretmen kılavuzu*. Ankara: Ani Yayıncılık.
- Tay, B. (2011). Sosyal bilgiler öğretiminin dünü, bugünü ve yarını. *Icinde Sosyal bilgilerin temelleri*. Turan, R. ve Ulusoy, K. (Ed.). Ankara: Pegem Akademi Yayıncılık, 1-18.
- Ozturk, C. (2007). *Hayat Bilgisi ve Sosyal Bilgiler Öğretimi*. Bursa: Ezgi Kitabevi.
- Ozturk, C. ve Otluoğlu, R. (2003). *Sosyal bilgiler öğretiminde edebî ürünler ve yazılı materyaller*. Ankara: Pegem Akademi Yayıncılık.
- Paykoc, F.(1995). *İlköğretim Kurumlarında Sosyal Bilgiler Öğretimi ve Sorunları*. Türk Eğitim Derneği Öğretim Dizisi. Ankara: Safak Matbaacılık.
- Yıldırım, A. ve Simsek, H. (2011). *Sosyal bilimlerde nitel araştırma yöntemleri*. Ankara: Seckin Yayıncılık.
- Weeden, P. (1997). *Learning through maps, in Daniella Tilburyand Michael Williams (ed) Teaching and Learning Geography*, 168-179, London: Routledge.





# Designing Web-based Situated Learning Environment in Teacher Training<sup>1</sup>

Ibrahim Gokdas

## 1. Introduction

Creating an effective learning environment that links theoretical knowledge with practical experience is significant for filling the theory-practice gap in teacher training (Brouwer & Korthagen, 2005; Korthagen & Kessels, 1999). Many studies emphasize the importance of learning experiences (Hoekstra, Beijaard, Brekelmans & Korthagen, 2007). For this reason, teacher training programs need to be designed in such a way as to help teacher candidates gain experience (Leaman & Flanagan, 2013). Situated learning is a prominent model for teacher candidates within the context of filling the theory-practice gap and supporting them to gain experience (Martin & Ertzberger, 2013) because situated learning requires knowledge to be presented in authentic contexts. It emphasizes that knowledge cannot be known and completely understood independent from its context (David, Chalon, Champalle, Massarey & Yin, 2007).

The literature puts forth researches supporting the view that situated learning can be used successfully as an instructional model (for example; Bransford, Sherwood, Hasselbring, Kinzer & Williams, 1990; Cognition and Technology Group at Vanderbilt [CTGV], 1990, 1993a, 1993b; Griffin, 1995; Young, 1993). For this reason, Situated Learning (SL) applications have gained importance in the recent years, taking into consideration the need to train "21<sup>st</sup> century professionals" who need collaboration and problem solving skills in different contexts and situations (Gardiner, Corbitt & Adams, 2009; Lunce, 2006; Meyers & Lester, 2013). On the other hand, the fact that the use of mobile technology is now widespread offers many opportunities to learn and to support performance both in and outside the classroom (Martin & Ertzberger, 2013).

Therefore, situated learning has begun to be included in instruction gradually together with the theories and research findings. Situated learning has been applied in many fields such as language learning (Pirainen-Marsh & Tainio, 2009; Shih & Yang, 2008; Yang, 2011; Wu, Sung, Huang & Yang, 2010), science teaching (Bell, Maeng & Binns, 2013; Sadler, 2009), increased reality (Chang & Liu, 2013; Yusoff, Zaman & Ahmad, 2010), teacher training (Bella & Mladenovic, 2015; Gokdas, 2003; Leaman & Flanagan, 2013; Huang, Lubin & Ge, 2011; Shaltry, Henriksen, Wu & Dickson, 2013), teaching technologies training (Huang, et al., 2011; Kucuk, 2017), stressful work areas (Bose & Ye, 2013), and math's education (Ticknor, 2012).

Situated learning model has such an appearance that can support teachers to gain experience in pre-service training programs considering its general characteristics and the opportunities that information technologies offer. In this study, the subject how a learning environment that can support the applicability of the web-based situated learning model in pre-service teacher training programs should be designed was examined based on the literature.

## 2. Situated Learning

The concept of situated cognition was originally put forth by Brown, Collins and Duguid (1989). Learning within the context of situated cognition is considered as a social phenomenon. Therefore, learning is described as an output of social interaction rather than forming the human mind (Harley, 1993). Individual differences of students and their learning cultures can also lead to different perceptions and interpretations within a similar context. Besides, situated learning is a powerful metaphor for human learning which includes everyday cognitive elements, informal learning,

---

<sup>1</sup>*Part of this study is summarized from the doctorate dissertation of the author.*

authentic learning experiences and cultural influences (Brown et al., 1989; Griffin & Griffin, 1996; Wilson, 1995a). Situated cognition emphasizes that knowledge is in the situations present in the social structure. Situated learning focuses on how knowledge can be obtained on the basis of the concept of situated cognition.

According to Jonassen (1991), learning occurs only when the activities are similar to real situations. Fitzsimmons (2001) emphasized that authentic learning is effective learning and includes real life situations since real life involves both the structured and unstructured problems and conditions. The individual reaches knowledge in authentic activities and tries to find solutions to the problem by specifically restructuring knowledge. According to Brown et al. (1989), situated learning occurs when students undertake duties as apprentices in a particular discipline, not in the learning environments in which they are passive. If it is determined how people solve problems in certain situations, it becomes easier to teach how the problems are solved.

There are four key points of situated learning experiences that will enable the development of classroom activities. These are: (1) Learning is based on daily situations, (2) Knowledge is acquired situationally and is only transferred to similar situations, (3) Learning is formed as a result of such social processes as thinking, perception, problem solving and interaction, and (4) Learning is not separated from real life events, but occurs in strong, complex and social settings (Anderson, Reder & Simon 1996; Wilson, 1995).

In situated learning, students learn by working on events, not from the program organized and structured by the teacher. Content is instinctively acquired when the task is performed and is not independent from usual life conditions and interaction (Stein, 1998). Interaction is important in the situated learning model. For this reason, the student should definitely participate in the practice community. In situated learning, knowledge is seen as the practical skills for regulating and doing. Learning is the ability to participate in true events as a community. Therefore, learning is socially situated and it is important that students are in interaction and involved in situations in terms of providing learning (Evans & Heidegger, 1999). With regard to the implementation of situated learning in class, Stein (1998) emphasizes that learning will be achieved by totally getting into the experiences rather than scrutinizing previous experiences.

### 3. The Components of Situated Learning

McLellan (1996) stated the key components of situated learning as stories, reflection, technology, collaboration, cognitive apprenticeship, coaching, multiple practice and articulation learning skills. While applying situated learning approach, it is necessary to perform various activities within the limits prescribed by these components. The components that are the basis of situated learning approach are outlined below in general terms.

**Stories.** In order for situated learning model to be implemented, first of all, it is necessary to have a context in which students will work. This context is stories. Stories play a significant role in the transfer and discovery of knowledge. Stories help the discoveries of students and provide meaningful structures to remember what they have learned (McLellan, 1996). That's why, the stories reflecting real-world settings take place within the implementation of the situated learning approach. Other components forming situated learning approach are generally implemented or used while working on these stories.

**Reflection.** Reflection can be explained as the fact that the student learning in a certain context expresses knowledge, after reaching and internalizing it, verbally or non-verbally in the way as he structured it (Herrington & Oliver, 1996). Through the realization of reflection in the situated learning process, learners can focus on their actions, compare themselves with others' activities, summarize what they learn and make the summary or criticism of the process for beginners (Collins, 1990). Reflection is important in terms of allowing students to express their own perceptions about what they learn, how they learn and what all the knowledge is for.

**Technology.** Technology is another important component of situated learning approach in terms of providing the presentation and interaction opportunity for the context (stories) to be worked on in

the learning process. The transfer of real-life contexts into the classroom setting becomes even easier with the developing technologies. It can reflect real-life events in the classroom by such media as videos, animations or virtual reality, or can present almost-real contexts to students. In these settings, students find a piece of their own lives and begin to think and decide how and in what point of their lives they will use what they have learned (Winn, 1993). Rapid development of technology offers opportunities for the realization of the expected interaction in the implementation process of situated learning. Virtual classes, video conferencing, chat programs, and e-mail are some of them.

**Collaboration.** In the implementation of situated learning, the students are expected to be in interaction with the environment in the learning process. One of the best practices for interaction is collaborative learning activities because learning is provided in a collaborated social process. Situated learning environments enable the use of interactive multimedia resources within a social context. In this regard, students work in groups, discuss problems, present the discovered skills and make reciprocal interviews. Thus, students can express their opinions clearly and provide various negotiations (Herrington & Oliver, 1995). Collaboration is important because it helps students to construct knowledge by providing different perspectives to be learned about the task being worked upon and about sharing knowledge.

**Cognitive apprenticeship.** The supporters of the cognitive apprenticeship presume that people acquire many skills in the context of real life and refine these skills by implementing them to new situations. For this reason, they emphasize that students should be matched with a guide or a more experienced student when beginning to learn a new concept (Brown et al., 1989). More experienced students help the inexperienced students who begin to construct a new information through cognitive apprenticeship or fulfill the specialist need by performing as their coaches (Griffin & Griffin, 1996). The fact that a student working in a context can implement or use what he has learned in real life conditions requires an experienced expert guidance at first. The student who has just participated in the learning process may have the chance to use what he has learned by means of the support provided at the cognitive level.

**Coaching.** Training provides scaffolding and guidance for the students working on a task in order to let them learn how to proceed when necessary. In the coaching process, the teacher undertakes the role of a guide, a team leader and providing collaboration rather than a director (McLellan, 1996). Carrying out coaching in the implementation process of situated learning approach requires assisting the learners' problem solving, helping them when they need, and providing different perspectives for the problem (Collins, 1990). Coaching necessitates the teacher to be a good observer and to know his students. The teacher will be able to put forward an idea about what his students can do and to what extent by taking into account their past experiences in the problem solving process; and he will be able to provide the necessary guidance by more easily identifying the students in need of help.

**Multiple practice.** In multiple practices, work is defined by the actions of students, rather than passive acquisition of processed information. The students are expected to adapt their work to new environments and contexts instead of doing what they already know (McLellan, 1996). The practices repeated over and over in order to perform multiple practices provide significant support for the skills to deepen and root in the social context where reflection and collaboration occurs (McLellan, 1996; Ataizi, 1999). Multiple practices that allow the individual to exhibit progress alone also support the transfer of knowledge.

**Articulation of learning skills.** There are two dimensions of articulation. The first emphasizes the concept of totally disassembling or articulating all of the different components of the skills in order to learn. The second is the articulation of the students' knowledge, problem solving processes or reasoning skills in a certain area (McLellan, 1996). Students can produce knowledge that may be used in different contexts by means of articulation, and can compare the strategies that may be used in different contexts. Students will have the opportunity to see the problems from other students' perspectives and thus, produce the knowledge that is not clearly defined and spoken (Collins, 1990).

#### **4. Web-based interactive multimedia design where situated learning model can be implemented in teacher training**

The rapid development and possibilities presented in information technologies provide important advantages in terms of the applicability of teaching-learning models. Especially the widespread use of mobile technologies offers significant opportunities for learning and supporting performance both in the class and outside the class. Students have the opportunity to benefit from mobile technology and get support not only in the class, but also while walking around within the context of learning. Mobile technologies support the access to information, the management of learning processes and the improvement of the learners' performance in terms of communication through constant access everywhere (Lacina, 2008; Martin & Ertzberger, 2013; Meurant, 2010; Sheppard, 2011). Mobile technologies support situated learning practices with such applications as bluetooth, 2D and 3D barcodes, videos and photos, etc.

New mobile devices make authentic activities easier than ever before. Mobile devices can let learners gain active experience in a context. Mobile technologies present the opportunity to access instantly to information and reconstruct it. Therefore, a content can be created for learners and the content can be accessed. While the learners are working on a task, they can make notes about their perceptions of the context, document their observations related to the environment, record local voices, share them with others, and develop projects (NMC, 2009).

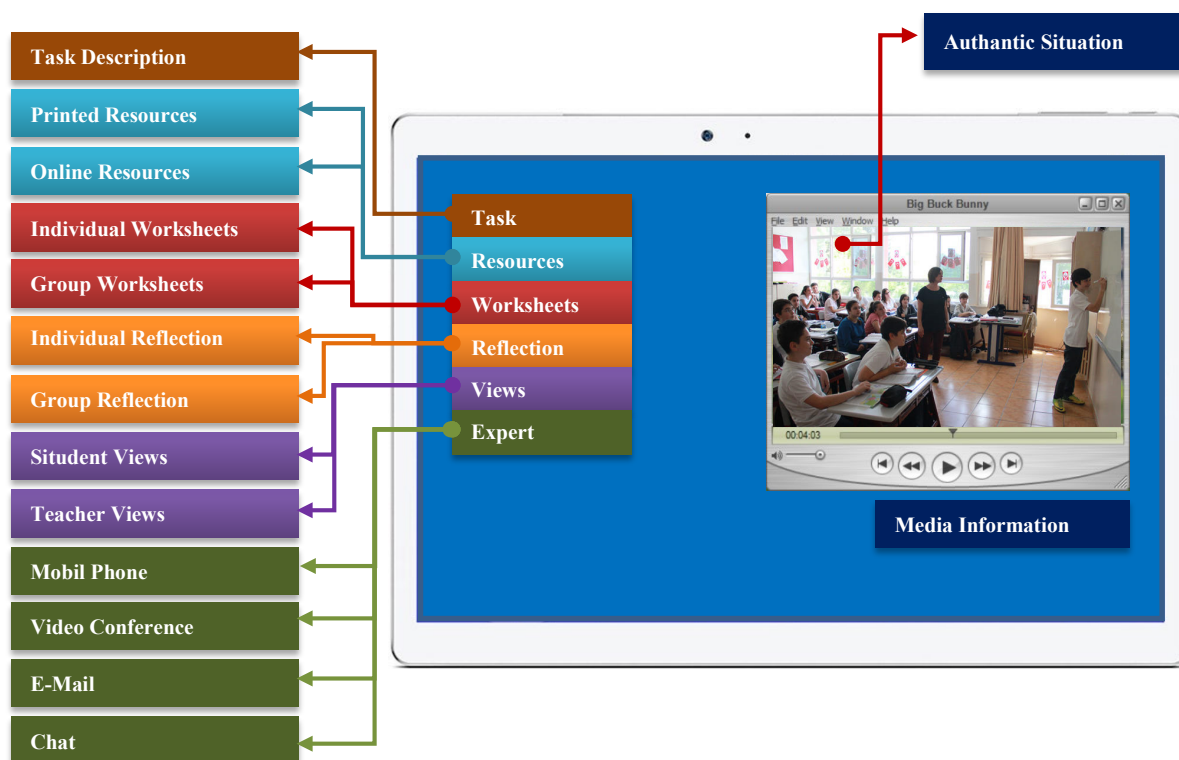
Situated learning model is, by nature, a model open to the active use of instructional technologies. However, it is suggested to take into consideration the fact that certain features should be included in designing interactive multimedia developed in accordance with situated learning approach. Herrington and Oliver (1995) focused on two main topics related to these suggestions. These were the role of the designer and that of the student. The role of the designer for the interactive multimedia program is to provide authentic context, authentic events, expert performance and multiple roles and points of view. In order for the students to be able to perform his role in situated learning process, it is necessary to provide such opportunities as collaboration, reflection, articulation, management and scaffolding, and integrated evaluation.

Teachers also have a duty in the use of interactive multimedia. This duty varies according to the role the teacher adopts. Herrington and Oliver (1996) stated that the teacher who will undertake duty in interactive multimedia had three roles. These were given as a transmitter, manager, and coach.

In a setting where interactive multimedia material designed in accordance with situated learning approach is applied, the teacher needs to act as a coach. It is noteworthy to express that this role is to provide general scaffolding to learners and to guide them. Herrington and Oliver (1995) ranked the media elements expected to be found in the multimedia material peculiar to situated learning environment as: (1) To show an authentic example of the subject to be taught by a video footage prepared in real settings, (2) To present the video footages including the teachers' views about the approach and their thoughts on the strengths and weaknesses of each approach, (3) To provide video footages showing the students' interpretations on the strategies, (4) To allow interviews with the experts in the field so as to provide theoretical perspective, (5) To present the students that will use the source (such as software, website) the perspectives and suggestions of advanced and experienced students, (6) To provide descriptions related to the subject, (7) To present the students various examples of work to let them carefully examine the resources and the work presented in the scenario, (8) To include electronic notebook application that enables the students to write their own thoughts and ideas within the program and to copy the texts from the files, (9) To enable the students to examine the test resource related to authentic subjects presented.

The following is an example of designing situated learning model within the context of information technologies that will enable the teacher candidates to gain experience in the areas such as special instructional methods, classroom management, and time management during their preservice training. This sample design can be improved by the practitioners according to the purpose.

## Designing Web-based Situated Learning Environment in Teacher Training



**Figure 1.** Designing Web-based Situated Learning Environment in Teacher Training

**Authentic Situation:** It is composed of video footages taken in the classroom setting during the course without any outside intervention, which reflect the social context that teacher candidates will work on.

Classroom videos are an important resource in the acquisition of pedagogical information. Videos can facilitate innovative learning by being integrated into teacher training intuitively (Seidel, Blomberg & Renkl, 2013).

It is argued that observing classroom videos can help teacher candidates to link their university education with their later classroom practices. Therefore, video can fill the gap between theory and practice (Abell & Cennamo, 2004; Seidel et al., 2013).

**Task:** Teacher candidates may be asked to perform various tasks by defining them on the video footages taken in the real classroom setting without any intervention. Within the context of this task, teacher candidates will have task descriptions and roles about how they can resolve to smaller tasks, what information is needed, and what solution offers can be developed for the identified problems (Herrington & Oliver, 1996).

**Resources:** Resources include the sources of information that teacher candidates may need while working on a task. The designer can support teacher candidates to gather information about the subject by presenting the online addresses and the list of the printed and visual materials that can support them because working on a task assigned to teacher candidates requires to consider on a broader database. Interactive multimedia designers also believe that their programs must have satisfactory resource support (Herrington & Oliver, 1996).

**Worksheets:** By preparing online forms in which there are the questions they have to answer while working on the task, the designer can help teacher candidates to obtain and develop the necessary preliminary knowledge in terms of the fulfillment of the tasks by their students. Besides, these can support them to develop suggestions and alternative ways of completing the task. These worksheets that are presented online should be designed in such a structure to provide multiple applications and to let teacher candidates work both individually and in collaborative groups. In situated learning model designed in interactive media, it is suggested that the learners working on a social context should work in groups, discuss the topics, provide feedback, and present their findings (Herrington & Oliver, 1996).

**Reflection:** Situated learning environment requires reflection to ensure the creation of abstractions (Brown et al., 1989; CTGV, 1990; Collins, 1988; Collins, Brown & Newman, 1989; Resnick, 1987). Reflection is the structured questions that will enable teacher candidates to think in a metacognitive way, associate with what they have learned in different disciplines, and transfer what they have learned to different situations. The designer should create some sort of questions that will provide the reflections of teacher candidates in terms of the task being worked upon. These questions should be placed in the program with online forms.

**Views:** Video supports teacher candidates by presenting their teachers' practical work (Llinares & Valls, 2009), discussions and feedback (Masingila & Doerr, 2002) within the context of the situated learning model. It is composed of video and/or voice recording files including the views of the chosen student, teacher, expert and, when necessary, the related individuals such as the parent, the administrator, etc. These video and/or voice recording files are also seen to be necessary and important in terms of the learners to benefit from different points of view while working on the task.

**Expert Support:** Experts own advanced concepts which allow them to interpret typical classroom situations and understand students' thoughts in their own field within the context of teaching (Borko, 2004). For this reason, teacher candidates should be provided with online media where teacher candidates can communicate with the experts from whom they can receive support while working on the task. At that point, teacher candidates can receive support by communicating with the experts using such virtual platforms as video conference, e-mail, and chat.

**Media Information:** Information should be given about the authentic situation to be worked on. A text that answers such questions as "how many students are there in the class? What are the socio-economic characteristics of the environment where the school is located? What is the teacher's professional experience level?" can help the learners to make better decisions while working on the task.

**Integrated Assessment:** Integrated assessment includes the individual and group work reports prepared by teacher candidates while working on the task during and after the course and the evaluation of the reflection pages by the instructor. In general, all the performance of teacher candidates during the process they are working on the task must be evaluated in an integrated way. Various web 2.0 tools can also be used during the evaluation process (for example; Class Dojo, Team Up, etc.).

Each application given above in headings can be varied in line with the task assigned to students. Different activities can be organized by taking into account the basic components of the situated learning. The tasks that can contribute to the performance of learners within the process can be included.

## 5. Discussion and Conclusion

The inability to provide teacher training with an integrity of theory and practice led to the investigation of the insufficiency of the application dimension. As situated learning model presents task-based work opportunity on real-life situations, it seems to support the solution to the problem. However, the applicability of situated learning requires technology support significantly. Together with the fact that the emergence of situated learning in the 1990s is significant, it is observed that the widespread use of it in the learning environments is not at the desired level. Experiencing such a situation stems from the fact that, considering the period, information technologies had limited features. Nowadays, taking into account the opportunities offered by information technologies, it is possible to access information, communicate, and record and share real-life situations anytime and anywhere. The fact that experimental work has become widespread after 2005 (for example: Bell, et al., 2013; Bose & Ye, 2013; Chang & Liu, 2013; Huang, et al., 2011; Kucuk, 2017; Ticknor, 2012; Sadler, 2009; Yusoff, Zaman & Ahmad, 2010) can be considered as an indicator of this situation. When literature is reviewed, it can be observed that there are studies (Bella & Mladenovic, 2015; Gokdas, 2003; Leaman et al., 2013; Huang, et al., 2011; Kucuk, 2017; Shaltry, et al., 2013), though limited, in terms of situated learning practices in teacher training programs.

Designing web-based situated learning environments in which the opportunities offered by information technologies in pre-service teacher training process can be benefitted from has such a structure that can contribute teacher candidates to gain experience. Especially mobile technologies, various web 2.0 application tools, virtual reality and enhanced reality applications, and artificial intelligence applications offer a wide range of opportunities for performing the implementations in terms of stories, reflection, technology, collaboration, cognitive apprenticeship, multiple practice and the articulation of learning skills, which are the basic components of learning. Therefore, designing and implementing web-based situated learning environments based on mobile technologies will enable to provide theory and practice integrity in pre-service teacher training process and carry out implementation activities in line with the purpose. Within this context, disseminating situated learning model in pre-service teacher training programs and presenting learning environments in accordance with situated learning model enhances by technology integration is regarded to be significant.

## 6. References

- Abell, S. K., & Cennamo, K. S. (2004). Videocases in elementary science teacher preparation. In J. Brophy (Ed.), *Using video in teacher education* (pp. 103-130). Oxford, UK: Elsevier.
- Anderson, J. L., Reder, L., & Simon, H. (1996). Situated learning and education. *Educational Researcher*, 25(4), 5-11
- Ataizi, M. (1999). *Bilgisayar destekli durumlu ogrenmede bilissel bicim ve icerigin gerceklik duzeyinin sorun cozme becerilerinin gelismine etkisi. [The effects of cognitive style and authenticity level on development of problem solving skills during computer-based situated learning]* (Yayınlanmamış doktora tezi). Anadolu Universitesi. Sosyal Bilimler Enstitüsü, Eskisehir, Türkiye
- Bell, R. L., Maeng, J. L., & Binns, I. C. (2013). Learning in context: technology integration in a teacher preparation program informed by situated learning theory. *Journal of Research in Science Teaching*, 50(3), 348-379.
- Bella, A., & Mladenovic, R., (2015). Situated learning, reflective practice and conceptual expansion: effective peer observation for tutor development. *Teaching in Higher Education*, 20(1), 24-36. Retrieved from <http://dx.doi.org/10.1080/13562517.2014.945163>
- Borko, H. (2004). Professional development and teacher learning: mapping the terrain. *Educational Researcher*, 33(8), 3-15. Retrieved from <http://dx.doi.org/10.3102/0013189X033008003>
- Bose, M., & Ye, L. (2013). Antecedents of situated learning in stressful service experiences: a cross-cultural study. *Journal of International Consumer Marketing*, 25, 219-233. doi:10.1080/08961530.2013.803897
- Bransford, J. D., Sherwood, R. D., Hasselbring, T. S., Kinzer, C. K., & Williams, S. M. (1990). Anchored instruction: Why we need it and how technology can help. In D. Nix and R. Spiro (Eds.), *Cognition, Education and Multimedia: Exploring Ideas in High Technology*, Hillsdale, NJ: Lawrence Erlbaum, pp. 115-141.
- Brouwer, N., & Korthagen, F. (2005). Can teacher education make a difference? *American Educational Research Journal*, 42(1), 153-224
- Brown, J. S., Collins, A., & Duguid, P. (1989). Situated cognition and the culture of learning. *Educational Researcher*, 18(1), 32-42
- Chang, Y. H., & Liu, J. (2013). Learning in a ubiquitous learning environment. *TOJET: The Turkish Online Journal of Educational Technology*. 12(3), 21-32
- Collins, A. (1990). Reformulating testing to measure learning and thinking. In N. Frederiksen, R. Glaser, A. Lesgold, & M. Shafto (Eds.), *Diagnostic monitoring of skill and knowledge acquisition* (pp. 75-88). Mahwah, NJ: Lawrence Erlbaum.
- Collins, A. (1988). Cognitive apprenticeship and instructional technology (Technical Report No. 6899). BBN Labs Inc., Cambridge, MA.



- Collins, A., Brown, J. S., & Newman, S. E. (1989). Cognitive apprenticeship: Teaching the crafts of reading, writing, and mathematics. In L.B. Resnick (Ed.), *Knowing, learning and instruction: Essays in honour of Robert Glaser, Hillsdale, NJ: LEA*, pp. 453-494.
- CTGV. (1993a). Anchored instruction and situated cognition revisited. *Educational Technology*, 33(3), 52-70.
- CTGV. (1993b). Designing learning environments that support thinking: The Jasper Series as a case study. In T. M. Duffy, J. Lowyck and D. H. Jonassen (Eds.), *Designing Environments for Constructive Learning*, Berlin: Springer-Verlag, pp. 9-36.
- CTGV. (1990). Anchored instruction and its relationship to situated cognition. *Educational Researcher*, 19(6), 2-10.
- David, B., Chalon, R., Champalle, O., Massarey, G., & Yin, C. (2007). Contextual mobile learning: a step further to mastering professional appliances. *IEEE Multidisciplinary Engineering Education Magazine*, 2(3), 5-9.
- Evans, K., & Heidegger, G. (1999). Proposal: situated learning and "re-integration initiatives" for young people: policies and practices. Paper presented at the European Conference on Educational Research, Lahti, Finland 22-25 September 1999. Retrieved from <http://www.leeds.ac.uk/educol/documents/00001279.ht>**
- Fitzsimmons, J. (2001). Designing an effective online unit: Theory and practice. *Paper presented at the Teaching Online in Higher Education Online Conference*, Indiana University-Purdue University Fort Wayne, Indiana. Retrieved from <http://www.ipfw.edu/as/tohe/2001/abstracts/fitzsimmons.htm>.
- Gardiner, L. R., Corbitt, G., & Adams, S. J. (2009). Program assessment: getting to a practical how-to model. *Journal of Education for Business*, 85(3), 139-144.
- Gokdas, I. (2003). *Bilgisayar ve sınıf ortamına dayalı durumlu öğrenmenin öğrenci başarısı, tutum ve transfere etkisi [Effect of computer and classroom settings based situated learning on student success, attitude and transfer]*. (Yayınlanmamış doktora tezi). Ankara Üniversitesi Eğitim Bilimleri Enstitüsü, Ankara, Türkiye
- Griffin, M. M. (1995). You can't get there from here: Situated learning, transfer and map skills. *Contemporary Educational Psychology*, 20, 65-87.
- Griffin, M. M., & Griffin, B. V., (1996). Situated cognition and cognitive style: Effect on students' learning as measured by conventional tests and performance assessments, *Journal of Experimental Education*, 64(4), 293-309
- Harley, S. (1993). Situated learning and classroom instruction. *Educational Technology*, March, 46-51
- Herrington, J., & Oliver, R. (1996). The effective use of interactive multimedia in education: Design and implementation issues. In: *3rd International Interactive Multimedia Symposium: The learning superhighway: New world? New worries?*, 21 - 25 January 1996, Perth, Western Australia. Retrieved from <http://researchrepository.murdoch.edu.au/id/eprint/7172/>
- Herrington, J., & Oliver, R. (1995). Critical characteristics of situated learning: Implications for the instructional design of multimedia. In: *ASCILITE 1995 Conference, 3-7. December 1995*, (pp. 253-262). University of Melbourne, Melbourne. Retrieved from <http://www.ascilite.org/conferences/melbourne95/smtu/papers/herrington.pdf>
- Hoekstra, A., Beijaard, D., Brekelmans, M., & Korthagen, F., (2007). Experienced teachers' informal learning from classroom teaching, *Teachers and Teaching*, 13(2), 191-208. Retrieved from <http://dx.doi.org/10.1080/13540600601152546>
- Leaman, L. H.; Flanagan, T. M. (2013). Authentic role-playing as situated learning: Reframing teacher education methodology for higher-order thinking, *Studying Teacher Education*, 9(1), 45-61, ERIC Number: EJ997994
- Huang, K., Lubin I. A., & Ge, X. (2011). Situated learning in an educational technology course for pre-service teachers. *Teaching and Teacher Education*. 27, 1200-1212.
- Jonassen, D. H., (1991). Objectivism versus constructivism: Do we need a new philosophical paradigm? *Educational Technology Research and Development*. 39(3), 5-14
- Korthagen, F. A. J., & Kessels, J. P. A. M. (1999). Linking theory and practice: changing the pedagogy of

- teacher education. *Educational Researcher*, 28(4), 4-17.
- Kucuk, S. (2017). Durumlu ogrenme yaklasimina dayali egitim teknolojileri ogretimi [Situated Learning Based Educational Technology Instruction: Preservice Teachers' Experiences]. *Egitim Teknolojisi-Kuram ve Uygulama*, 7(2), 276-298.
- Lacina, R. (2008). Technology in the classroom: learning English with iPods. *Childhood Education*, 84(1), 247-249.
- Leaman, L. H., & Flanagan, T. M. (2013). Authentic role-playing as situated learning: reframing teacher education methodology for higher-order thinking, *Studying Teacher Education*, 9(1), 45-61. doi:10.1080/17425964.2013.771573
- Llinares, S., & Valls, J. (2009). The building of pre-service primary teachers' knowledge of mathematics teaching: interaction and online video case studies. *Instructional Science*, 37(3), 247-271. Retrieved from <http://dx.doi.org/10.1007/s11251-007-9043-4>.
- Lunce, L. M. (2006). Simulations: bringing the benefits of situated learning to the traditional classroom. *Journal of Applied Educational Technology*, 3(1), 37-45.
- Martin, F., & Ertzberger, J. (2013). Here and now mobile learning: An experimental study on the use of mobile technology Author links open overlay panel Computers & Education, 68, 76-85. Retrieved from <https://doi.org/10.1016/j.compedu.2013.04.021>**
- Masingila, J. O., & Doerr, H. M. (2002). Understanding pre-service teachers' emerging practices through their analyses of a multimedia case study of practice. *Journal of Mathematics Teacher Education*, 5, 235-263. Retrieved from <http://dx.doi.org/10.1023/A:1019847825912>.
- McLellan, H. (1996). Evaluation in situated learning environment. McLellan, H. (Ed.). *Situated Learning Perspectives*. (pp. 101-112). USA: Educational Technology Publication.
- Meurant, R. C. (2010). iPad tablet computing to foster Korean EFL digital literacy. international journal of u- and e-service, *Science and Technology*, 3(4), 49-62
- Meyers, S., & Lester, D. (2013). The effects of situated learning through a community of partnership in a teacher preparation program. *Sage Open*, 3(3), 1-9.
- NMC. (2009). 2009 Horizon Report Australia-New Zealand Edition. Horizon Report. Retrieved from. <http://wp.nmc.org/horizon-anz-2009/section/location-based-learning/>.
- Piirainen-Marsh, A., & Tainio, L. (2009). Collaborative game-play as a site for participation and situated learning of a second language, *Scandinavian Journal of Educational Research*, 53(2), 167-183.
- Resnick, L. (1987). Learning in school and out. *Educational Researcher*, 16(9), 13-20.
- Sadler, T. D. (2009). Situated learning in science education: socio-scientific issues as contexts for practice, *Studies in Science Education*, 45(1), 1-42.
- Seidel, T., Blomberg, G., & Renkl, A. (2013). Instructional strategies for using video in teacher education. *Teaching and Teacher Education*, 34, 56-65.
- Shaltry, C., Henriksen, D., Wu, M. L., & Dickson, W. P (2013). Teaching pre-service teachers to integrate technology: situated learning with online portfolios, classroom websites and facebook. *TechTrends*. 57(3), 20-25
- Sheppard, D. (2011). Reading with iPads-the difference makes a difference. *Education Today*. 3, 12-15
- Shih, Y. C., & Yang, M. T. (2008). A collaborative virtual environment for situated language learning using VEC3D, *Educational Technology & Society*, 11(1), 56-68.
- Stein, D. (1998). Situated learning in adult education. *ERIC Digest No. 195. No. ED418250*. Columbus, OH: ERIC Document Reproduction Service. Retrieved from <https://www.ericdigests.org/1998-3/adult-education.html>
- Ticknor, C. S. (2012), Situated learning in an abstract algebra classroom. *Educ Stud Math* 81, 307-323. doi: 10.1007/s10649-012-9405-y
- Wilson, B. G. (1995). Metaphors for instruction: Why we talk about learning environments. *Educational Technology*, September/October. 25-30
- Wilson, B. G. (1995a). Situated instructional design: Blurring the distinctions between theory and practice, design and implementation, curriculum and instruction. In M. Simonson (Ed.),

*Proceedings of selected research and development presentations.* Washington D. C.: Association for Educational Communications and Technology. Retrieved from [https://www.academia.edu/17481032/Situated\\_instructional\\_design\\_Blurring\\_the\\_distinctions\\_between\\_theory\\_and\\_practice\\_design\\_and\\_implementation\\_curriculum\\_and\\_instruction?auto=download](https://www.academia.edu/17481032/Situated_instructional_design_Blurring_the_distinctions_between_theory_and_practice_design_and_implementation_curriculum_and_instruction?auto=download)

- Winn, W. (1993). Instructional design and situated learning: Paradox or partnership? *Educational Technology, 33*(3), 16-21.
- Wu, T. T., Sung, T. W., Huang, Y. M., & Yang, C. S. (2010), Location awareness mobile situated english reading learning system, *Journal of Internet Technology, 11*(7), 923-933.
- Yang, Y. F. (2011). Engaging students in an online situated language learning environment, *Computer Assisted Language Learning, 24*(2), 181-198.
- Young, M. F. (1993). Instructional design for situated learning. *Educational Technology Research and Development, 41*(1), 43-58.
- Yusoff, R. C. M., Zaman, H. B., & Ahmad, A., (2010). Design a situated learning environment using mixed reality technology-A case study. world academy of science, *Engineering and Technology 47*, 884-889

# Investigating The Means Of Providing Vocational School Students With Improved Language-Learning Environments: The Case Of Davutlar Vocational School

Bertan Akyol, Bilge Sevim Okuyan, Erhan Coskun

## 1. Introduction

In Turkey, numerous studies, projects, and reforms have been implemented to improve the ways English is taught and used since the second half of the 20<sup>th</sup> and 21<sup>st</sup> centuries. Although the significance of effective communication in a foreign language is a known fact, proficiency in English and acquisition of communicative skills are still one of the biggest problems in Turkish education system. A report prepared in 2017 by EF Education First Schools exemplifies the situation further: this report is the world's largest English proficiency ranking by countries. It is published annually. In this ranking, Turkey has remained in the "very low proficiency" band for the last three years (2015, 2016, 2017). In 2017 ranking, it is the 62<sup>nd</sup> of 80 countries and 26<sup>th</sup> of 27 European countries.

Another report published in 2014 by British Council and Tepav provides a national insight. It is titled *A National Needs Analysis Concerning English Language Teaching in State Schools in Turkey (Turkiye'deki Devlet Okullarında İngilizce Dilinin Öğretimine İlişkin Ulusal İhtiyac Analizi)*. According to one of the findings, the proficiency level of most primary and secondary education students in Turkey (more than 90%) remains elementary even after more than 1000 hours of English classes.

This situation proves that the present education policies and foreign language teaching methods fail to provide the learners with communicative language skills. A large body of research indicates that English is taught as a series of subjects to be memorized and to be tested with written exams rather than a medium of communication.

### 1.1. Communicative Language Teaching

Communicative language teaching (CLT) can be generally defined as teaching a language with an emphasis on meaning making and communicating in the target language. Mehmet Demirezen (2011) reminds that CLT first appeared in Britain in the 1970s as an ESL (English as a Second Language) methodology. Defining CLT can be a difficult task as it means different things to different teachers and learners. According to Nina Spada, "[w]hile most descriptions of CLT emphasize the communication of messages and meaning, there is disagreement as to whether CLT should include a focus on the analysis and practice of language forms" (p. 1).

Three methods have been popular in Turkey since the 1960s. These are Grammar-Translation Method, Audio-Lingual Method, and Direct Method (Arslan & Akbarov, 2009). These methods rely on memorizing language structures. They have proved to be insufficient when it comes to teaching how to communicate in English. On the other hand, CLT prioritizes communicating in a foreign language and advocates a sustainable language education in different contexts. Tahsin Aktas (2005) defines CLT as follows:

Communicative competence means the knowledge and abilities necessary to communicate with a language community. In other words, it requires using the signs in a language in different contexts in a timely and meaningful manner...This type of competence requires distinguishing who to communicate, what to say, and how to express ideas in certain situations. (p. 90)

As Aktas emphasizes, communicative competence is not something that can be achieved merely through memorizing pieces of information or rules. The ability to use "the signs in a language in different contexts in a timely and meaningful manner" can be acquired by perceiving the language within particular social and cultural contexts. For example, a language learner should be able to use

various grammatical structures and vocabulary in different social roles for asking for and giving information, making requests, making discussions, giving instructions, and giving advice etc.

### 1.2. Generative Multimedia Learning Theory

Including technology in foreign language learning environments can make significant contributions to language teaching and learning. Using technology for language teaching and learning enables learners to participate in the learning process actively and independently; to use more than one sense simultaneously; and to cooperate with teachers more often.

Buket Akkoyunlu and Meryem Yilmaz (2005) classify the technologies for teaching in an article which addresses generative multimedia learning theory comprehensively. Their classification is based on the senses to which these technologies are directed: visual media, audio media, and audio-visual media. Although the article mentions various definitions of generative multimedia learning, Akkoyunlu and Yilmaz define the term simply as the media that addresses more than one sense and transmits different types of data.

Generative multimedia learning theory was developed by Richard E. Mayer in 2001. Mayer, in his book *Multimedia Learning* (2001), states that presenting a subject or explanation in words and pictures stimulates better understanding for learners than words alone. The desired outcome of this type of learning is meaningful learning which can be obtained by good retention of the media and good transfer performance (1).

Studies which advocate that multimedia should be included in language teaching (Altinisik & Cakir, 2002; Baturay, Yildirim & Daloglu, 2007; Saran, Seferoglu & Cagiltay, 2009; Saran & Seferoglu, 2010) all conclude that generative multimedia learning theory encourages meaningful and permanent learning and increases learners' motivation.

## 2. Method

### 2.1. Research Model

The study is a part of the English multimedia classroom project implemented in Adnan Menderes University, Davutlar Vocational School. In order to determine and solve the problems of low levels of academic success and motivation, action research was undertaken in the school setting. This model is suitable for such projects due to the fact that the researcher is both the practitioner and the observer of their operations and concerns (Aydogan & Gundogdu, 2015). Eileen Ferrence (2000) defines action research as "a process in which participants examine their own educational practice systematically and carefully" (1). According to some classifications, action research is a type of qualitative research (Aydogan & Gundogdu, 2015).

The implementation of the multimedia classroom project in Davutlar Vocational School consisted of four steps: needs analysis, creating media, implementation, and evaluation. The needs analysis was done in the fall term of academic year 2016-2017 at Davutlar Vocational School. 10 students from the Culinary Arts Program were selected and interviewed about their opinions on English for Occupational Purposes (EOP) courses. Their responses were analyzed by means of content analysis technique. This study determined the concerns and needs of the students who stated that they needed more speaking activities and audio-visual material during the EOP classes.

The second step was creating media. This was done taking into account the specific language learning problems and needs of the students studying in the programs of Culinary Arts, Catering Services, Tourism and Hotel Management. The equipment, furniture and media used in the classroom were a computer, a projector, loudspeakers, a printer, posters, CDs and DVDs, a bookshelf, and tablet arm chairs.

The third step was to implement the media. Communicative language teaching activities were designed to engage students in meaningful learning through multimedia. The classroom was put into use in October 2017. The need for more speaking and pronunciation practice on the part of students was met by means of audio-visual material. The main goal was to leave the outworn methods aside and

adopt communicative teaching approaches in order to stimulate the learners' creativity and participation. The implementation step lasted two months.

The final step was to evaluate the efficiency of communicative activities done by using multimedia in the classroom. To this end, a group of students were asked to compare the English classes characterized by teacher-centered grammar-translation method to their new learning environment.

## 2.2. Sampling

The sample of the study was drawn from Adnan Menderes University, Davutlar Vocational School. Five students were selected by means of convenience sampling method from the three main programs, namely Culinary Arts, Catering Services, Tourism and Hotel Management. The participants were both first year and second year students. The participants in their first year of study take English Speaking Skills classes. The ones in their second year of study take English for Occupational Purposes classes. Culinary Arts students do not take any English classes during their first year of study; therefore, they are not included in the study.

## 2.3. Data Collection and Analysis

The data were collected, after the implementation and during the evaluation step, through semi-structured interviews. The interview questions were prepared by the researchers. They were reviewed by three specialists and revised in accordance with specialists' comments. The final version of the interview form contained five questions. The researchers sought voluntary participation and each participant was given a code for the confidentiality of their answers. The data were analyzed by means of content analysis method. The answers were directly quoted in the "Findings" section.

## 3. Findings

The multimedia in Davutlar Vocational School English classroom were put into use from October 2017 until the end of December 2017. Five participants, who had taken English Speaking Skills and English for Occupational Purposes classes in this classroom, were interviewed about the effects of the multimedia and the new seating arrangement on permanent learning and motivation.

The first interview question asked the level of participants' proficiency in English language skills (writing, speaking, listening, reading). Four participants stated that their English proficiency level was pre-intermediate (A2), whereas one participant stated that it was intermediate (B1). All the participants stated that they had minor problems about their receptive skills (reading and listening). However, they found their productive skills (writing and speaking) poor. Some answers are presented below:

*K1: "Not very good. Maybe pre-intermediate. I can understand English, but I can't speak the language."*

*K2: "My English speaking skills are not very good, as I started studying the subject of tourism last year. I don't have much experience. I watch some movies and series in English. This has improved my reading and listening. I can't speak because I haven't practiced enough."*

*K3: "...good listening skills, but I have serious problems with speaking. I take the English classes very seriously as I think they will help with my studies and career. Writing is not too bad. I believe it will be better."*

The second question asked whether the multimedia and other visual material, such as the posters, were adequate for their language learning needs. All the participants found the computer, projector, and loudspeakers adequate in terms of enriching their learning environment. Two participants suggested that the number of visual material could be increased. One participant added that student projects could also be displayed along the posters. Some of the answers are as follows:

*K1: "Seeing slides on the board is fun. I understand better when I see things."*

*K2: "There should be more posters. I'm not sure about the audio equipment. It all comes down to individual effort. The facilities can be increased in number."*

*K3: "I think they are adequate. Could they be improved? Yes. The classes should be interesting. For example, we can put name stickers on classroom objects."*

*K4: "Because English is all about hearing, it is good for us to have loudspeakers. They are necessary for speaking activities."*

K5: *“Visuals are adequate. I remember things better. There could be a large bulletin board on the wall for student projects. We must make something. It is better when we hear the language.”*

The third question of the interview was about the new seating arrangement. One part of the project was to dismantle the desks which had been fixed to the ground. Our purpose was to provide the students with more mobility so that they could move their chairs around for group activities. Three participants stated that moving the chairs around and working with peers increased student cooperation.

K1: *“Each student can express their ideas. Everybody sees the whole classroom and share ideas. With fixed desks, the front of the classroom was separated from the back. That was not good. People were disconnected.”*

K4: *“I definitely believe it is better compared to the fixed desks. This lesson requires dialogue. With the fixed desks, we could talk only to the person next to us. When I was sitting at the front, I couldn’t talk to the ones at the back. I like it better when we are face to face.”*

K5: *“Participation increases. Students mingle and socialize. They share.”*

Participants also evaluated the tablet arm chairs in terms of classroom management. Three participants stated that the new seating arrangement helped the instructor with the classroom management. However, two participants cautioned the researchers against over-socialization among the students. They stated that close friends should not be seated together.

K1: *“When chairs are mobile, the students begin to disperse. A pre-arranged seating chart would help. We should sit away from our good friends. Otherwise we become distracted.”*

K2: *“With the fixed desks, sometimes our teacher walked along the rows and we were chatting when she was not looking. That was a major student problem created again by the students. Now we sit in a U-shaped arrangement and the teacher has more control over the class. As we all have separate chairs now, we create our own private zone and get distracted less.”*

K3: *“I find the new seats good. You have to listen to the conversations now. You cannot hide at the back. When I hide, I become distracted and demotivated. The U-shaped seating makes me focus on the teacher.”*

K5: *“These chairs motivate me. Close friends should not sit together. When we sit in a circle, we focus better. It is also good for teacher’s control over the class.”*

The fourth question was about the effects of multimedia and visuals on permanent learning. All the participants emphasized the positive effect of visuals on permanent learning. Two participants used the term “visual memory.”

K1: *“When I hear only the words, I forget. When I see things, I remember.”*

K2: *“When there are pictures and when the subjects are accompanied by visuals, I remember things better.”*

K3: *“As I said before, you can’t remember things when you see them just once. You need to see it again and again before it becomes permanent. My visual memory is very strong. I never forget a thing I see. Pictures work for me.”*

K4: *“As I believe visual memory is important for learning, I definitely find this classroom useful.”*

K5: *“The more the better. Even if you take a quick look at the posters, the words stick in your mind.”*

Two participants emphasized the importance of audio material.

K2: *“When I encounter some words in English, I remember the meaning with sounds. When you practice listening long enough, you don’t need to think about the translation.”*

K5: *“Our teacher speaks English in the classroom, but that wasn’t enough for us. Loudspeakers are very useful.”*

The fifth and final question asked whether the specially-designed English classroom, the multimedia, and the additional visuals affected the participants’ language learning motivation. All the participants mentioned a positive effect on their motivation.

K1: *“Better now.”*

K2: *“As you know, being in a classroom is an obligation for students. This kind of material makes things more interesting.”*

K3: *“I think I am affected positively. I have always wanted to learn English since my early childhood. The only sentence I know is ‘What is your name?’ Nothing improved my English. As I see these changes in*

*this classroom, I become motivated and believe in my potential. Then I start to make an effort. I feel lucky and I don't want to waste this chance."*

*K4: "This room is fun. It's better than naked walls and a boring atmosphere."*

*K5: "Learning English is important. The posters and the equipment will make things more interesting."*

One participant stated that similar projects should be implemented in other classrooms at Davutlar Vocational School.

*K2: "This could be done in the other classrooms. At least the seating arrangement could be changed. We study tourism and we need motivation. This is already a belated attempt."*

#### 4. Conclusion

As a result of the semi-structured interviews with five students studying Culinary Arts, Catering Services, and Tourism and Hotel Management at Davutlar Vocational School, some themes about the multimedia in the English classroom have emerged.

First of all, English proficiency level of the participants is pre-intermediate (A2). They have major issues with productive language skills (speaking and writing). According to a study conducted in the academic year 2016-2017 with ten students selected from Culinary Arts Program, the fact that students had not received a permanent and sustainable education in English affected their language learning at college. They brought along their disappointment, worries and learned helplessness to their college education (Okuyan and Sezgin, 2017). Participant who listed similar problems emphasized the importance of multimedia in stimulating motivation and supporting permanent learning. In addition to the multimedia, the participants also mentioned the U-shaped seating arrangement with regard to student participation and cooperation.

Before the implementation of the project, the needs analysis step highlighted the need for audio-visual material. It was assumed that the audio-visual material would increase the amount of speaking and listening exercises in the classroom. The interviews done after the implementation confirmed this assumption. The consistency in the participants' views concerning the increase in their learning motivation and permanent learning indicated the efficiency of the project.

It is expected that the long-term use of multimedia in the English classroom will highlight the benefits of the project, which are permanent learning, an increase in student motivation, and a learning environment characterized by sharing and interaction. It is also expected that the multimedia in the classroom will encourage the students to engage in communicative activities. It is suggested that similar projects are designed and implemented for the subjects of study and classrooms not only at Davutlar Vocational School, but also the other schools at Adnan Menderes University.

#### References

- Akkoyunlu, B., & Yilmaz, M. (2005). Turetimci coklu ortam ogrenme kurami. *Hacettepe Universitesi Egitim Fakultesi Dergisi*, 28, 9-18.
- Altinisik, S., & Orhan, F. (2002). Sosyal bilgiler dersinde coklu ortamin ogrencilerin akademik basarilari ve derse karsi tutumlari uzerindeki etkisi. *Hacettepe Universitesi Egitim Fakultesi Dergisi*, 23, 41-49.
- Aktas, T. (2005). Yabancı dil ogretiminde iletisimsel yeti. *Journal of Language and Linguistic Studies*, 1 (1), 89-100.
- Arslan, M., & Akbarov, A. (2010). Turkiye'de yabancı dil ogretiminde motivasyon-yontem sorunu ve cozum onerileri. *Selcuk Universitesi Edebiyat Fakultesi Dergisi*, 24, 179-191.
- Aydogan, R., & Gundogdu, K. (2015). Ilkokul ogrencilerine yönelik hazirlanan bir sorumluluk programinin yansimalari: bir eylem arastirmasi. *Journal of Theory and Practice in Education*, 11 (3), 1061- 1088.
- Baturay, M. H., Yildirim, S. I., & Daloglu, A. (2007). Web-tabanlı İngilizce kelime ogretimi ve tekrar modeli. *Politeknik Dergisi*, 10 (3).
- British Council. (2014). *Turkiye'deki Devlet Okullarında İngilizce Dilinin Ogretimine Iliskin*



- Ulusal ihtiyaç Analizi.* Retrieved from [http://www.tepav.org.tr/upload/files/13993885191.Turkiyedeki\\_Devlet\\_Okullarinda\\_Ingilizce\\_Dilinin\\_Ogrenimine\\_Iliskin\\_Ulusal\\_Ihtiyac\\_Analizi.pdf](http://www.tepav.org.tr/upload/files/13993885191.Turkiyedeki_Devlet_Okullarinda_Ingilizce_Dilinin_Ogrenimine_Iliskin_Ulusal_Ihtiyac_Analizi.pdf)
- Cakir, I. (2006). The use of video as an audio-visual material in foreign language teaching classroom. *The Turkish Online Journal of Educational Technology*, 5 (4), 67-72.
- Demirezen, M. (2011). The foundations of the communicative approach and three of its applications. *Journal of Language and Linguistic Studies*, 7 (1), 57-71.
- Ferrance, Eileen (2000). *Themes in Education: Action Research*. Providence: LAB.
- Haznedar, B. (2010). Turkiye’de yabancı dil eğitimi: reformlar, yönelimler ve öğretmenlerimiz. *International Conference on New Trends in Education and Their Implications*. Ankara.
- Mayer, R. E. (2001). *Multimedia Learning*. Cambridge: Cambridge University Press.
- Okuyan, B., & Sezgin, A. (2017). Meslek yüksekokulları asçılık programı öğrencilerinin mesleki İngilizce dersine ilişkin görüşleri. *Uluslararası Meslek Yüksekokulları Sempozyumu*. Sozlu bildiri. Saraybosna.
- Saran, M., Seferoglu, G., & Cagiltay, K. (2009). Mobile assisted language learning: English pronunciation at learners' fingertips. *Egitim Arastirmalari-Eurasian Journal of Educational Research*, 34, 97-114.
- Saran, M., & Seferoglu, G. Yabancı dil sozcuk öğreniminin çoklu ortam cep telefonu iletileri ile desteklenmesi. (2010). *Hacettepe Üniversitesi Eğitim Fakültesi Dergisi*, 38, 252-266.
- Sife A. S., Lwoga E.T., & Sanga C. (2007). “New technologies for teaching and learning: challenges for higher learning institutions in developing countries”. *International Journal of Education and Development*, 3 (2), 57-67.
- Spada N. (2007) Communicative language teaching. In: Cummins J., Davison C. (Eds) *International Handbook of English Language Teaching*. Springer International Handbooks of Education, vol 15. (pp.271-288). Boston: Springer.
- The EF English Proficiency Index Seventh Edition. (2017). Retrieved from [www.ef.com.tr/epi/](http://www.ef.com.tr/epi/)

# The Village Teacher Training Trials in Turkey, Mahmudiye Instructor Course and Mahmudiye Village Teacher Training School

Ilhan Kulaca, Adil Adnan Ozturk

## 1. Introduction

Before the Balkan War, Anatolia people were tired of war and mobilization orders. Within and after The Balkan War and The First World War, they were plunged into darkness and gave up hope of their future.

Ottoman General Mustafa Kemal Pasha, having achievements in to lots of fronts, was looking for a remedy for liberation with a group of his friends who believed him. As mentioned in Amasya Circular “*independence of the nation’s determination and decision will save the nation*”. After Amasya Circular and Congresses, M. Kemal, came to Ankara on 27 December 1919. Turkish Grand National Assembly; opened on 23 April 1920; founded the regular army. For the struggle, especially against the Greek regular army was the first and the most significant condition for him.

M.Kemal was aware of limited possibilities than inviting the help of suffering Anatolian people who were doomed, poor and ignored for centuries. The idea of founding firstly an army then a young republic that can adapt to the needs of the age was his biggest ideal (Kansu,1968). He gave importance to both the victory of war and the enlightenment of Anatolian people who were abandoned to ignorance. In the course of Kutahya-Eskisehir War, despite all objection, organizing Education Congress in the sign of this.

M.Kemal visited Ismet Pasha who was about to become desperate. He looked at the window and saw the women who had digger, trowel, water jug in their hands and said: “*Let’s get rid of it Ismet*”. When he said that, it was a dream of educated, free from poverty and happy people lived in Turkey (Ozakman,2005).

Lozan Peace Treaty was signed on 24 July 1923. It is historical document which shows that the Ottoman Empire was destroyed and replaced with an Independent Turkey and that it was approved by the powerful states of Europe, Asia, America and especially the victors of the World War (Turan,2012).

Churchill represented M.Kemal as “*the man of the century*”. The war of Independence was won by M.Kemal and self devotion of Anatolian people. As M.Kemal indicated, the real war was started now. He had to fight ignorance and the education system had to be taken care of. Because, it was the main reason which has led the nation to disaster for 300 years. More than 80% of the population lived in the village, so if the villagers did not developed, the country could not develop. Facing village and villagers, at the same time, was a duty of loyalty to Anatolian people who were the most significant part of National Struggle.

Berkes (2016:522) in his work, points out the two aspect of Turkish Society’s modernisation: “*Bringing up the Turkish Society to the trajectory of civilization has two aspects: The first side, which we can see plenty of samples in this book, is to eliminate the traditionalist attitude. The secondside, instead, is to establish the rules, to establish the transition bridge between the ages by cultivating the new generations of society according to the needs of this trajectory*”. This relationship could only be established with training. The work that had to be done was not simple of course, but to throw off the centuries backward, especially from the villagers and the nation.

Till 1940s, although important steps were taken in the period, there were many things to get over. According to the population census in 1935, 12.400.952 of the country’s population, namely the 80%, lived in villages. Early 1940s, there were 40.000 villages in Turkey and there was no school in 35.000 of these villages. In 1935, in Turkey, now all senior educators have exhausted their suggestions for the village’s education problem. They were all inconclusive finally, they all came to the same point (Kirby,2015).

In order to save the country from this backward state, someone was needed who knew the country well. This need was solved by bringing Saffet Arikan to Ministry of National Education on 11.06.1935 (Tonguc,1947). The biggest problem to overcome for Saffet Arikan was to bring school and teacher to the villages of the country. For the General Directorate of Primary Education, a qualified person was needed to overcome this. Ismail Hakki Tonguc was a person that Arikan was looking for (Kirby,2015). According to Tonguc, the village issue was not a uniform development, but a conscious revival of the village. The villagers should be relieved of turbaned literate and the village teacher should be replaced. If the village does not develop, the continuity of the regime and reforms can not be ensured. It would disappear before it could reach the society. Tonguc prepared a report to Saffet Arikan. In this report, demographic structures of the villages were discussed and the village teachers were encouraged to be chosen from the village (Tonguc,1947).

The report submitted by Tonguc, directed Saffet Arikan to Mahmudiye. He started the process of opening Mahmudiye Village Training School and Instructor Course which would later become a model to all over the country.

## **2. Material and Methods**

In this study, scanning model is used. For this reason, founded in Mahmudiye, Mahmudiye Instructor Course and Mahmudiye Village Teacher Training School's accesible documents were scanned in the archives. Relevant sources were investigated. Interviews were made up with the students who are alive especially graduated from Cifteler Village Institute. Audio and video records were taken. The school campus has been investigated in some buildings that are still used today. Interviews were made up with the people in Mahmudiye and the contribution of the school to it's environment was investigated. Descriptive analysis method is used to analyze the datas.

## **3. Results and Discussion**

Although 13 years had passed since the proclamation of the Republic, no progress has been made on the development and education of the villagers. This situation disturbed those who sought a solution to this situation in Turkey. According to Tonguc (1947), Turkey was a nation for behind Europe in terms of primary education activities in 1934. This problem caused to opening Mahmudiye Village Training School and Instructor.

### **3.1. Mahmudiye Instructor Course**

Minister of Culture Saffet Arikan in 1936, shared his idea that those who would be assigned as teachers to three-class-schools to be opened in villages, should be chosen from the youth who had made their military service as corporal and sergeant. Because it was decided that sergeants and corporals should be chosen from the ones with abilities in terms of their education success and hard work (Basgoz,2016).

The petition number 6/65627, signed by Minister of Culture, General Director of Primary Education, Saffet Arikan on 3 August 1936, was sent to the Prime Ministry. In this petition, permission was requested for the Village Teachers and Trainers Course, which was planned to be opened in the village of Mahmudiye, Cifteler Farm. The instruction includes the basic issues such as the wages and salaries of the agricultural teachers who will take part in the course will be met by the Ministry of Agriculture, the cultural lesson teachers will be charged by the Ministry of Culture, the farm facilities and buildings will be used, and the large staff will be formed in cooperation with the Ministry (Anadolu University,2009).

The opening Mahmudiye Village Teachers and Trainers Course was officially accepted in Decree no 2/5494 on a legal basis by the Law of eight-item Village teachers on 11.06.1937. Thus, the way of employing trainers has been opened to villages whose populations were unsuitable for sending teachers (Koy Egitmenleri Kanun ve Talimatnamesi,1938). One month before the letter which Saffet Arikan sent to the Ministry it is understood from the work of Turkoglu (2017) that the first rehearsal of the course was made. In July 1936, the first trainers were trained in Mahmudiye Village of Eskisehir. Cifteler Studfarm here to be installed, tools and technical staff, training of trainers would benefit who finishes

### The Village Teacher Training Trials in Turkey

this seven-month-course would be named as instructor, not teacher. The Director of the course was also the Director of Cifteler Studfarm, Numan Kirac. 84 participants from the villages of Ankara and Tunceli participated in the course (Tonguc,1947). The second course was opened in 1937, students from the villages of Eskisehir an Afyon began to be taken (Balkir,1968).

The second course was opened in Hamidiye at the same time with Mahmudiye, unlike the first one. The course in Mahmudiye was opened for the first students who did internship and came back, the course in Hamidiye was opened for candidates who would be educated for the first time (Balkir,1968).

The training period of Mahmudiye Instructor Course was limited to seven months. After the first four and a half months of training, students would go to their village for an internship, then return of the internship, was two and a half month more training (Tonguc,1997). The Course were; Arithmetic, Geometry, Homeland and Living Knowledge, Workshop Classes, Education Knowledge (Bayram,1999).

After the Agriculture Congress in 1938, according to a report by the Ministry of Agriculture, Mahmudiye and Cifteler Studfarm were chosen as the horse breeding and agricultural practice field of the country. As a matter of fact, the democratic formation of people, tendency to work together with the studfarm and the hand-to-handedness of people were the reason to be chosen. People in Mahmudiye's contribution to the breeding of animals had great support. Again in those years, Mahmudiye Inrtuctor Course, Cifteler Village Institute who used the lands of Studfarm were in solidarity with the public (Emiroglu and Yuksel,2009).

According to the work of Mahmudiye Village Instructor Course Education Chief S.Edip Balkir (1968), students were separated into groups as Ergenekon, Cankaya, Tinaztepe, Altiok, Sakarya, Gocyolu, Bozkurt, Kocatepe, Inonu. The work of the students before and after the afternoon were determined. Groups alternately participated in Workshops, Course Applications, Construction, Field Agriculture, Culture lesson, Free Reading Activities from 07.00-20.30. A daily run program can be seen in Table 1 and Table 2 below.

**Table 1.** Mahmudiye Instructor Course11.10.1937 Monday Study Program Before Afternoon

Work	Clusters	Time
Free Reading	All Clusters	07.00-08.00
Workshop	Kocatepe	08.00-10.00
Workshop	Dumlupinar	10.00-12.00
Course Application-Writing	Gocyolu, Bozkurt, Ergenekon	08.00-12.00
Course Application-Writing	Inonu, Sakarya	08.00-12.00

Resource: (Balkir, 1968:193)

**Table 2.** Mahmudiye Instructor Course11.10.1937 Monday Study Program Afternoon

Work	Clusters	Time
Guard	Altiok	-
Construction	Kocatepe	14.00-17.30
Workshop	Tinaztepe	13.30-15.30
Workshop	Inonu	15.30.-17.30
Zootechnics	Dumlupinar, Sakarya, Gocyolu	14.00-15.30
Canning	Bozkurt, Ergenekon, Cankaya	14.00-15.00
Canning	Dumlupinar, Sakarya, Gocyolu	15.30-17.00
Free Reading and Writing	All Clusters	19.30-20.30

Resource: (Balkir, 1968:194)

As Ozkucur (2015:216) mentioned in his work, although the curriculum seemed to be heavy, the work in the course was not more difficult than the work of village life, all of which were peasant children. Ozkucur: "...Collecting stones, trees, digging up soil and shoveling was farm labourer's job in our village. Those who did this were called as 'worker' Here it is called 'work job' and those who work are called 'students' ". In the second month, the trainees have turned success into an issue of honor and they have gone far beyond the expected success (Tonguc, 1997). The same effort and efficiency can be seen in Edirne course as mentioned in Bayir's (1971) work. Bayir talks about village teachers with respect and admiration, giving examples to some of these trainers who spend 12 hours of the day working tirelessly.

The campaign for education which started with the schools opened by the graduates of the Instructor Course has increased significantly in the villages of Anatolia over the next 20 years. The contribution of the graduates hasn't only been about teaching illiteracy. For the development of the village, which has been neglected for centuries, they were intended to be guide people to keep up with the age and to keep up with the innovations.

### 3.2. Mahmudiye Village Teacher Training School

The success of Mahmudiye Instructor Course also affected the opening of primary school in Mahmudiye. When the opening dates of the schools in Mahmudiye were examined, the fact that the were equal to 1938 proves this success. At the same time, this succes encouraged Ismail Hakki Tonguc and the Ministry to spread village education to Turkey. In the academic year, Kizilcullu Village Teacher Training School and Eskisehir/Mahmudiye Village Teacher Training School was officially opened on 30.10.1937 in the college which was purchased from the Americans in Izmir. This date was also the beginning of the process of Village Institutes (Tonguc,1997).

The reason that brought Hasan Ali Yucel to Ministry of National Education, whose name was identified with Village Institutes, were formed spontaneously. Saffet Arıkan, who worked on Primary Education issues, resigned from the Ministry due to the health problems. Hasan Ali Yucel, became the Ministry of National Education on 28.12.1938. Hasan Ali Yucel has survived this year's grieving period by "turning pain into work" (Turkoglu, 2017).

During the first months of the Ministry, Hasan Ali Yucel worked to legalize Village Teacher Training Schools. In 1939, the law no.3704 on the "Administration of Village Instructor Courses and Village Teacher Training Schools" has been enacted (Gedikoglu,1971). Thus, Mahmudiye Village Teacher Training School also had a legal status. Peasant children were admitted from Eskisehir, Konya, Afyon, Ankara, Kutahya province to the school of Mahmudiye Village Teacher Training. When you look at the Cifteler Village Institute diploma book, it is seen that the first graduates are from Eskisehir and Konya. In the selection of students to school, regional selection examination were effective done by the inspectors. In his work Ozkucur (2015) wrote that he was a beekeeper on an islet in Lake Beysehir, and that he attended the exam with malaria and became successful. 30 Turkish Liras entrance money was received from the students who would be admitted (Burgac,2004). Then reduced to 20 Turkish Liras (Apaydin,2017). After the school became Cifteler Village Institute, the registration fee was abolished. Instead, a written engagement was started to be invited from the students' parents. This is understood the written engagement that belongs to Sabri Cicek, the son of Huseyin Cicek, Kilbasan Village in Karaman, 13.07.1940 (Yunusemre Vocational and Technical Anatolian High School Archive).

Education and training activities would start without losing time. The building, which was inherited from American College, gave Kizilcullu an advantage. In Mahmudiye, there was no building to be used, except for the building whose authenticity has been lost today and the primary school building of the Instructor Course. The building shortage was resolved by the construction of a three-storey building in Hamidiye in 1938. In the construction of the building, the Hungarian Construction foreman Sili Layos, the instructor and the students worked. Students had a hard winter until the building shortage was resolved. The Principal Remzi Ozyurek often went to Eskisehir, working day and night to meet the needs of the school (Tonguc,1997). In some of the buildings in Mahmudiye, the first teachers, Ankara Construction Foreman School, villagers, village teachers and the first graders of the school have great support (Koc,2013).

Today both Mahmudiye Public Education Center, Osmangazi University Mahmudiye Horsebreeding Vocational School buildings and Hamidiye Campus buildings were built by the co-operation with teachers and students. So, it was a process that made the education given by the teachers valuable for the students. During this construction process, life-lesson events were experienced.

On the meeting with Ahmet Oztuna (Interview, 23.08.2017, Eskisehir), graduated from Cifteler Village Institute in 1944: "We set up the dorm, I was carpenter. Sili Layos was our teacher and construction foreman. Barns, sheep pens and so on were made. One day, I was hitting the tree with an adze, unintentionally, absently. Sili came 'what are you doing?' he asked. 'Nothing' I answered. Sili was a Hungarian. He grabbed

the wood. 'shoot' he said. 'I don't shoot' I said. He just looked at my face and I understood that he wanted to say 'the materials are valuable, do not harm them'. It was a life-lesson." By saying these words, he gave information about building construction works and memories about Sili Layos teacher. The experience gained at Mahmudiye Village Teacher Training School, minimized the difficulties that the Cifteler Village Institute would experience.

Mahmudiye Village Teacher Training School was made up of three parts. These were Primary School, Secondary School and Teacher Training School in the Primary School 4. and 5. graders were studying. This was because the fifth grade schools in the villages were a small number graduates of the secondary school. The point that attracts attention here is that the Mahmudiye Village Teacher Training School would receive students after secondary school and Cifteler Village Institute which is the continuation of this school would receive students after primary school (Burgac,2004). Three-class school villages were very common, as we saw in the study of Mahmudiye Primary School archives. The opening of the five-grade primary schools in Mahmudiye was in 1942 and after which the Cifteler Village Institute gave its first graduates. As we mentioned before, the first students Of Mahmudiye Village Teacher Training School, were the first graduates of Cifteler Village Institute at the same time. They worked hard to build the constructions that the school needed. It can be said that, those who came to Cifteler Village Institute after 1943-1944 were more comfortable than the first graduates.

According to the main theme of Ozkucur (2015)'s work, one of the first students of the Mahmudiye Village Teacher Training School, the basic requirements of the school were obtained by the students' work. All the building requirements such as, school, workshops, bath, toilet, tank etc. were done by the students with their teachers. As he said during a meeting with Ilyas Kucukcan (Interview, 06.07.2017, Eskisehir) graduated from Cifteler Village Institute, "this was job training at work".

After Mahmudiye Village Teacher Training School became Cifteler Village Institute, students were educated for two more years and graduated from Cifteler Village Institute. Graduates of 1941-1942, 1942-1943, 1943-1944 were also the students of Mahmudiye Village Teachers Training School. There were also the first students of Cifteler Village Institute in 1944 graduates. They were graduated one year early because of the need of teachers in villages. They were trained for four years. All 33 students graduated in 1942 were sent to Hasanoglan High Village Institute. 57 students graduated in 1943. The whole of these two years were the students of Mahmudiye Village Teachers Training School. 312 students graduated in 1944. As we said before, among them were the first registered students (Kulaca, 2017).

Mahmudiye Village Teacher Training School left useful experiences to Cifteler Village Institute, after it became an Institute three years later. It tried to minimize the difficulties which Cifteler Village Institute would experience. When the Village Institute Law of post-1940 was drafted, psychological and pedagogical experiences gained here, provided idea background to Ismail Hakki Tonguc who visited Mahmudiye Village Teacher Training School for many times.

#### 4. Conclusion

The revolutionary cadre in the thought of creating a modern society after a state, from the tired nation of the years of National Struggle, have seen that success can not be achieved without the help of the villagers. At the point where all solution proposal were exhausted and Ismet Inonu considered the steps taken for education as a waste of time; Saffet Arikan and Ismail Hakki Tonguc found a more practical, cheaper and permanent way for the revival of village life and education. The solution was Mahmudiye.

Mahmudiye was not chosen by chance. Proximity to the capital city, ease of transportation, being a form from Ottoman Empire, the advantageous structure of agricultural tools and qualified personnel, Anatolia's typical terrestrial climate, people's adoption of the change and the reforms are some of the reasons that made Mahmudiye special. People's fondness for education gained the appreciation of people who knew the region, especially Rauf Inan and Ismail Hakki Tonguc. Tonguc, at the the school's sod-turning ceremony in Hamidiye, gave the honor of throwing the first mortar to the villagers of Hamidiye and showed them the respect.

Mahmudiye Instructor Course and Mahmudiye Teacher Training School following it, besides then Cultural lessons of city schools; Agriculture, Fruit growing, Vegetable gardening, Cooking, Poultry Husbandry, Beekeeping, Animal Husbandry, Small Construction, Carpentry, Black Smith, Human and Animal Health Courses and Arts were taught which city schools didn't have. With the authentic programs, the concept of "job training at work" was adopted. The instructors and teachers who were sent to villages went eagerly to the villages where they were born and raised, and they one of the first success of later school in Mahmudiye and other regions was because of this while many of those who grew up in the city and the studied in the city schools wanted to get out of the poor villages where they were assigned as teachers, the graduates of the Village Instructor Course and Village Teachers Training Schools worked as if they were fighting the backwardness in the village.

Even on summer holidays, in the school's construction, in the field, in the vineyard... working students were part of the village enlightenment, one of the most important projects of country development in the middle of the steppe. They established orchard, vineyard and forest in Mahmudiye-Hamidiye bays with the water they carried from Seydi Stream with tins. It is possible to see these trees today. The fact that Mahmudiye Village Teachers Training School's buildings in Mahmudiye are still being used is important in terms of showing the quality of the work done.

These schools, an opportunity for the village children to attend school, contributed to education of many talented village children such as Abdullah Ozkucur, Talip Apaydin, Mustafa Aydogan, Ahmet Oztuna... For example, Yesilyurt Village of Mahmudiye is 60 houses and there are 300 teachers in the village. It means five teachers per household. All of them were educated in Mahmudiye Village Teacher Training School and its continuation schools. Their children and grandchildren are well-educated, qualified people today. In a meeting with Baki Aydin (Interview, 30.07.2016, Yesilyurt Village-Mahmudiye) he said: "how would we attend school without Mahmudiye and Hamidiye?" The material and spiritual traces of Mahmudiye Instructor Course, Mahmudiye Village Teacher Training School are still visible in Mahmudiye and many villages of Anatolia.

#### 4.1. Research Suggestions

The concept of "job training at work" at Mahmudiye Instructor Course and Mahmudiye Village Teacher Training School is model that is needed in Turkish education system today. Because of the examination anxiety, even the science course is taught by solving tests and can not provide permanence in learning. The common result of the Works and interviews studied in the research is that the sense of applied education provides long-term permanence in learning. In Turkish Education System, curriculums should be organized according to this understanding and education should be taken away from the anxiety of examination.

#### 5. References

- Anadolu University. (2009). *Kurtulus ve aydinlanma Eskisehir arxiv belgeleriyle*. Ankara: Basak Matbaacilik.
- Apaydin, T. (2017). *Koy Enstitusu yillari*. Istanbul: Literatur Yayinlari.
- Balkir, S. E. (1968). *Eski bir ogretmenin anilari*. Istanbul: Ari Kitabevi.
- Basgoz, I. (2016). *Turkiye'nin egitim cikmazi ve Ataturk*. Istanbul: Pan Yayıncılık.
- Bayir, F.O. (1971). *Koyun gucu*. Ankara: Ulusal Basimevi.
- Bayram, F. (1999). *Ogrenmeyi ogreten ustalar*, Ankara: Kultur Bakanligi Yayinlari.
- Berkes, N. (2016). *Turkiye'de cagdaslasma*. Istanbul: Yapi Kredi Yayinlari.
- Burgac, M. (2004). *Cifteler Koy Enstitusu*. Unpublished master's thesis. Uludag University Social Sciences Institute, Bursa, Turkey.
- The written engagement that belongs to Sabri Cicek, the son of Huseyin Cicek, from Kilbasan Village in Karaman, Cifteler Village Institute 13.07.1940. Yunusemre Vocational and Technical Anatolian High School Archive, Mahmudiye, Eskisehir, Turkey.
- Emiroglu, K. Yuksel, A. (2009). *Yoldasimiz at*. Istanbul: Yapi Kredi Yayinlari.
- Gedikoglu, S. (1971). *Evreleri, getirdikleri ve yankilariyla Koy Enstituleri*, Ankara: Is Matbaacilik ve Ticaret.

### The Village Teacher Training Trials in Turkey

- Interview with Ahmet Oztuna (Interview, 23.08.2017, Eskisehir).
- Interview with Baki Aydin (Interview, 30 Temmuz 2016, Yesilyurt Village-Mahmudiye).
- Interview with Ilyas Kucukcan (Interview, 06 Temmuz 2017, Eskisehir).
- Inan, R. (1977). *50. Yilinda Turkiye Cumhuriyeti ve egitim*. Ankara: Turk Tarih Kurumu Basimevi.
- Kansu, M.M. (1968). *Erzurum'dan olumune kadar Ataturk'le beraber*. Ankara: Turk Tarih Kurumu Basimevi.
- Kirby, F. (2015). *Turkiye'de Koy Enstituleri*. Istanbul: Tarihci Kitabevi.
- Koc, N. (2013). *Turk kultur tarihi icerisinde Koy Enstituleri*. Istanbul: Ideal Kultur Yayıncılık.
- Kulaca, I. (2017). *Cumhuriyet donemi Mahmudiye'de egitim*. Unpublished master's thesis. Adnan Menderes University, Social Sciences Institute, Aydin, Turkey.
- Tarım ve Kültür Bakanlıkları Koy Egitmenleri Yetistirme Kursları Nesriyatı (1938) *Koy egitmenleri kanun ve talimatnamesi*. Istanbul: Devlet Basimevi.
- Ozakman, T. (2005). *Su cilgin Turkler*. Istanbul: Bilgi Yayınevi.
- Ozkucur, A. (2015). *Ogretmen olacagim*. Ankara: Ogretmen Dunyasi Yayinlari.
- Tonguc, I. H. (1947). *Egitim yolu ile canlandirilacak koy*. Istanbul: Remzi Kitabevi.
- Tonguc, E. (1997). *Bir egitim devrimcisi: Ismail Hakki Tonguc (yasami, ogretisi, eylemi)*. Ankara: Guldikeni Yayinlari.
- Turan, S. (2012). *Turk devrim tarihi*. Ankara: Bilgi Yayınevi.
- Turkiye Radyo ve Televizyon Institution (Producer), Ozakman, T. (Scenarist) and Oztan, Z. (Director). (1996). *Kurtulus* [Film]. Turkiye: Turkiye Radyo ve Televizyon Institution.
- Turkoglu, P. (2017). *Tonguc ve Koy Enstituleri*. Istanbul: Turkiye Is Bankasi Yayinlari.
- Yunusemre Vocational and Technical Anatolian High School Archive.





# The Comparison Between Turkey And Some Countries Having High Achievement In PISA In Terms of Gender Equality<sup>2</sup>

Ilknur Maya, Necmiye Pamuk

## 1. Introduction

In this study, current situation of Estonia, Finland, South Korea, Japan and New Zealand, which are successful in the International Student Assessment Program (PISA) with Turkey were comparatively analyzed in terms of gender equality. Gender equality in selected successful countries will be discussed in the education, employment and entrepreneurial dimensions. As a result of the findings obtained in the research result, it is intended to bring the new proposals for Turkey.

Education is a process that has occurred since the emergence of human beings, and the development of the community in which the person lives is shaped through education (Tastekin, S. 2018). Today, education systems have an important role in the development and development of countries as well as in the training of individuals with the necessary qualifications. For this reason, education is an important fact for a country that can not be left to chance by its policies and practices (Yilmaz, A. 2017). Education, a prerequisite for a productive and quality life in modern society, is a key concept in adapting to the rapid change and development process in the world. For this reason, it is very important for the education of the people of a society and the inclusion of all sectors of society (Directorate General of the Status of Women, 2012). It is emphasized that it is extremely important for women to take an active role in social life and to benefit equally from educational opportunities and opportunities at all levels in the report named "Women in Turkey" by Women's Status General Directorate, dated January 2018 (General Directorate of Women's Status, 2017).

Article 10 of the Convention on the Elimination of All Forms of Discrimination Against Women (CEDAW) which regulates the right of education imposes obligations to take all appropriate measures preventing discrimination against women on states parties to ensure that they have equal rights with men (Women in Turkey, 2018). Research shows that gender inequality emerges as a major problem in many countries around the world (OECD, 2017). Despite the OECD's recommendation for 2013 and 2015, gender inequality continues to exist in almost every field in many countries and progress on gender equality is very slow according to the report "The Pursuit of Gender Equality Uphill Battle" published on October 4, 2017 (OECD, 2017).

The aim of this research is to determine the elimination of gender inequalities as a priority issue for countries to achieve success in education with the assumption that gender equality, in other words, equality between men and women affects the education of countries positively. Gender inequalities that occur at every stage of education in many countries are indirectly affecting the work of women, especially those of disadvantaged individuals.

The PISA, which has been organized by the OECD every three years since 2000 and attended by 15-year-old students, is an assessment that countries are participating in order to determine their position at the international level in the globalizing world. PISA, which serves to help countries to see where they are in the global arena and to generate policy through comparisons, serves as a feedback mechanism in the determination, evaluation and development of the success of an education system. The education indicators obtained as a result of this evaluation contribute to the determination of the level of the countries in the field of education, the deficiencies to be remedied and the precautions to

---

<sup>2</sup> This study is supported by Canakkale Onsekiz Mart University Scientific Research Projects (BAP) Coordination Unit as Master Thesis Project. Project Number: SYL-2018-2512.

be taken (MEB, [http://pisa.meb.gov.tr/?page\\_id=18](http://pisa.meb.gov.tr/?page_id=18)). PISA, which is important for this reason, is accepted as a reliable data source for many researches, especially for educational research.

In this research, it is aimed to examine the dimension of education, employment and entrepreneurship in the case of gender equality of Estonia, Finland, South Korea, Japan and New Zealand from OECD countries participating in PISA and getting successful score above the average in the context of science and math literacy and reading skills assessment with Turkey. In this context, answers to the following sub-problems are searched:

1. How is gender equality of Estonia, Finland, South Korea, Japan and New Zealand performing well in PISA with Turkey in the field of education?
2. How is gender equality of Estonia, Finland, South Korea, Japan and New Zealand performing well in PISA with Turkey in the field of employment?
3. How is gender equality of Estonia, Finland, South Korea, Japan and New Zealand performing well in PISA with Turkey in the field of entrepreneurship?
4. What are the similarities and differences between Estonia, Finland, South Korea, Japan, New Zealand and Turkey in terms of gender equality in the field of education, employment and entrepreneurship?

The study will shed light on the researches to be done because it is the first of the studies in the field and the studies including comparison of Turkey with other countries in terms of gender equality in the field of education, employment and entrepreneurship are not seen too much. It is expected that the results of the research will provide an important contribution by filling the gap in the literature on "comparative education" and shed light on decisions made by education policy makers.

## 2. Method

Document analysis technique is applied in this research. Research universe includes countries OECD members participating in the most recent PISA (2012) and PISA (2015). Research sample includes Estonia, Finland, South Korea, Japan and New Zealand OECD countries participating in PISA and getting successful score above the OECD average in all exams and sufficient data with Turkey. For this reason, the sample of the research is constituted by the sample which is easily accessible from the purposeful sampling methods.

In particular, the report "The Pursuit of Gender Equality: An Uphill Battle" published by the OECD on 4 October 2017 was taken into consideration. Estonia, Finland, South Korea, Japan and New Zealand successful in PISA in terms of gender equality have been compared with Turkey in the study. Similarities and differences between countries are included.

## 3. Findings

### 3.1. How is gender equality of Estonia, Finland, South Korea, Japan and New Zealand performing well in PISA with Turkey in the field of education?

It is necessary to examine the PISA scores of countries that have been successful in PISA in order to examine gender equality in education. Table 1 shows selected successful countries having scores above the average of OECD countries in PISA with the scores of Turkey.

## The Comparison Between Turkey And Some Countries Having High Achievement

**Table 1.** Selected Successful Countries Having Scores Above the Average of OECD Countries in PISA with the Scores of Turkey.

OECD Average	Mean score in PISA 2012			Mean score in PISA 2015		
	Mathematics	Science	Reading	Mathematics	Science	Reading
	<b>494</b>	<b>501</b>	<b>496</b>	<b>490</b>	<b>493</b>	<b>493</b>
Estonia	521	541	516	520	534	519
Finland	519	545	524	511	531	526
South Korea	554	538	536	524	516	517
Japan	536	547	538	532	538	516
New Zealand	500	516	512	495	513	509
Turkey	<b>448</b>	<b>463</b>	<b>475</b>	<b>420</b>	<b>425</b>	<b>428</b>

Source: MEB. (2015). PISA Türkiye (2012) Ulusal Nihai Rapor.

<https://drive.google.com/file/d/0B2wxMX5xMcnhaGtnV2x6YWsyY2c/view>

MEB. (2016). PISA 2015 Ulusal Raporu.

[http://pisa.meb.gov.tr/wpcontent/uploads/2014/11/PISA2015\\_UlusalRapor.pdf](http://pisa.meb.gov.tr/wpcontent/uploads/2014/11/PISA2015_UlusalRapor.pdf)

It is worth noting that the scores of countries performing well in the PISA exceed 500 points in all the scores except New Zealand's 2015 mathematics literacy score. It is seen that the scores of successful countries selected for the research are considerably higher than the OECD average scores. On the other hand, the scores of Turkey are well below the OECD average for all assessments. PISA assessments, which help countries to see differences and deficiencies between other countries and to develop policies in this context, have been used as criteria in the selection of countries to be examined in terms of gender equality in this survey.

**Table 2.** Gender Status of Countries Performing Well in PISA and Turkey According to Education Level in 2000 and 2013

Country	Net primary enrollment rate (%)				Gross tertiary enrollment ratio (% of relevant age group)			
	2000 Yili		2013 Yili		2000 Yili		2013 Yili	
	Women	Men	Women	Men	Women	Men	Women	Men
Estonia	96	<b>97</b>	95	<b>95</b>	67	46	94	<b>63</b>
Finland	100	100	99	99	90	75	101	83
South Korea	100	99	97	98	59	96	82	109
Japan	-	-	100	100	45	52	<b>58</b>	65
New Zealand	99	99	98	98	79	54	94	65
Turkey	<b>90</b>	98	<b>94</b>	<b>95</b>	<b>21</b>	<b>30</b>	73	85

Source: World Development Indicators, (2016), The little data book on gender, 79- 83-113-119-156,- 213.

<https://data.worldbank.org/products/data-books/little-data-book-on-gender>

Table 2 shows primary school enrollment rates are higher in Estonia, Finland, South Korea, Japan and New Zealand performing well in PISA than the rates in Turkey. Primary school enrollment rate of women is 94% in Turkey in 2013. When we examine the rates of tertiary education enrollment, it is worth noting that women's enrollment rates are more than men in other countries except South Korea, Japan and Turkey. Another remarkable point in this table is that the rate of 21% of women's tertiary education enrollment rate in 2000, has risen to 73% in Turkey 2013.

**Table 3.** Distribution of Higher Education Population by Gender

Country	Distribution of Higher Education Population by Gender (25-34 year-olds)		
	Men	Women	Gender Gap
Estonia	30.7	51	-20.3
Finland	32.6	48.9	-16.4
South Korea	64.6	73.6	-9
Japan	58.3	61	-2.7
New Zealand	34.8	43.1	-8.4
Turkey	27.8	27.2	0.6
OECD	35.9	47.8	-11.9

Source: The Pursuit of Gender Equality An Uphill Battle, figure: 1.1 <http://www.oecd.org/gender/the-pursuit-of-gender-equality-9789264281318-en.htm>

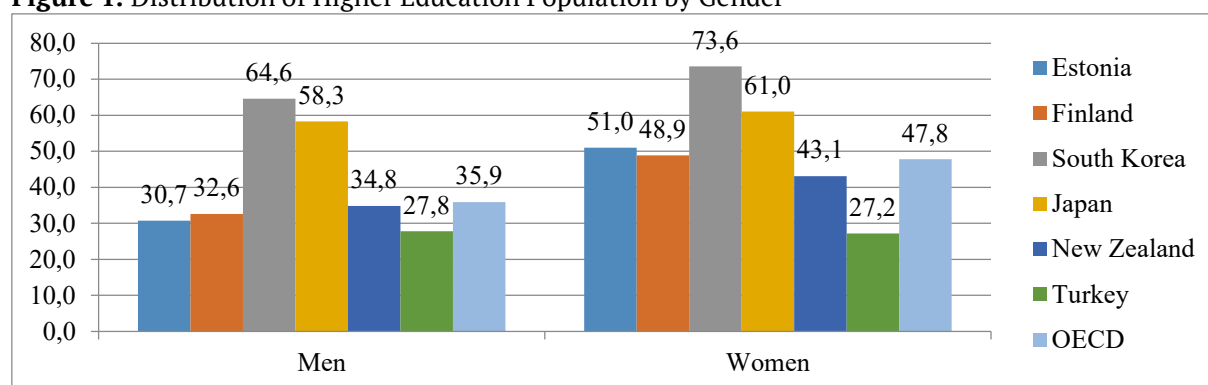
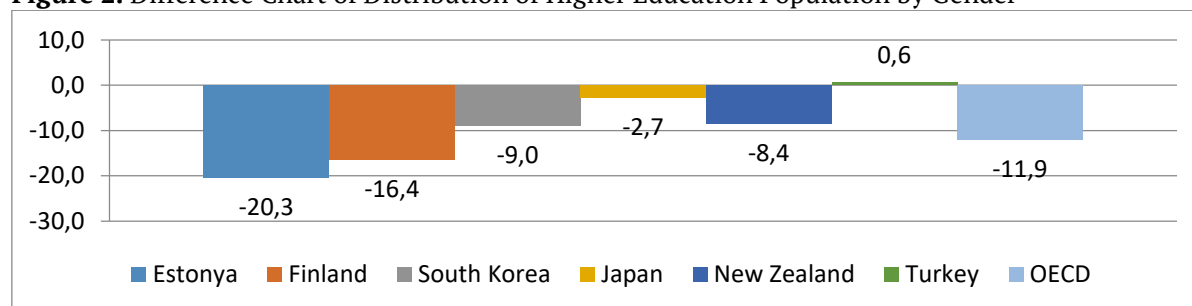
**Figure 1.** Distribution of Higher Education Population by Gender**Figure 2.** Difference Chart of Distribution of Higher Education Population by Gender

Table 3 shows distribution of higher education population by gender. It is seen that there is no gender gap in Estonia, Finland, South Korea, Japan and New Zealand performing well in PISA, which means that the proportion of female in tertiary education is higher. On the other hand, there is a gender gap of 0.6% in Turkey.

**Table 4.** Female Share of Graduates in Science, Mathematics and Computer (%)

Country	Female share of graduates in science, maths and computing (%) 2014 or latest
Estonia	46
Finland	42.6
South Korea	39.3
Japan	25.2
New Zealand	38.6
Turkey	50
OECD	39.2

Source: The Pursuit of Gender: An Uphill Battle, figure: 1.1 Access: <http://www.oecd.org/gender/the-pursuit-of-gender-equality-9789264281318-en.htm>

## The Comparison Between Turkey And Some Countries Having High Achievement

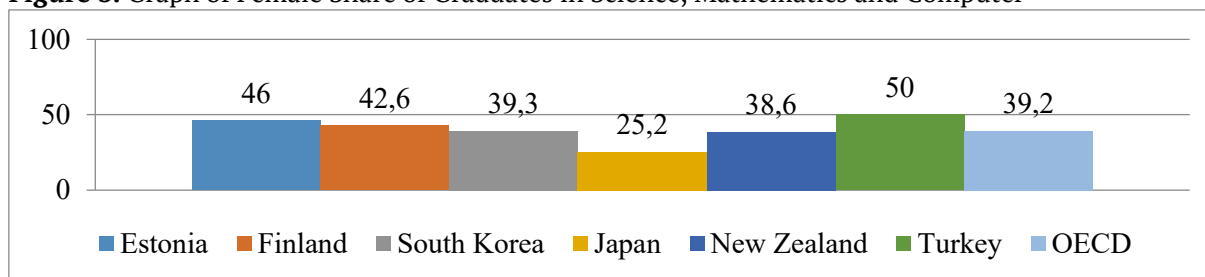
**Figure 3.** Graph of Female Share of Graduates in Science, Mathematics and Computer

Table 4 shows that the OECD average of graduates in science, mathematics and computer graduate female rate is 39.2% while it is 50% in Turkey. Rates of other countries are well below the rates of Turkey. The rates of Japan and New Zealand are also below the OECD average.

### 3.2. How is gender equality of Estonia, Finland, South Korea, Japan and New Zealand performing well in PISA with Turkey in the field of employment?

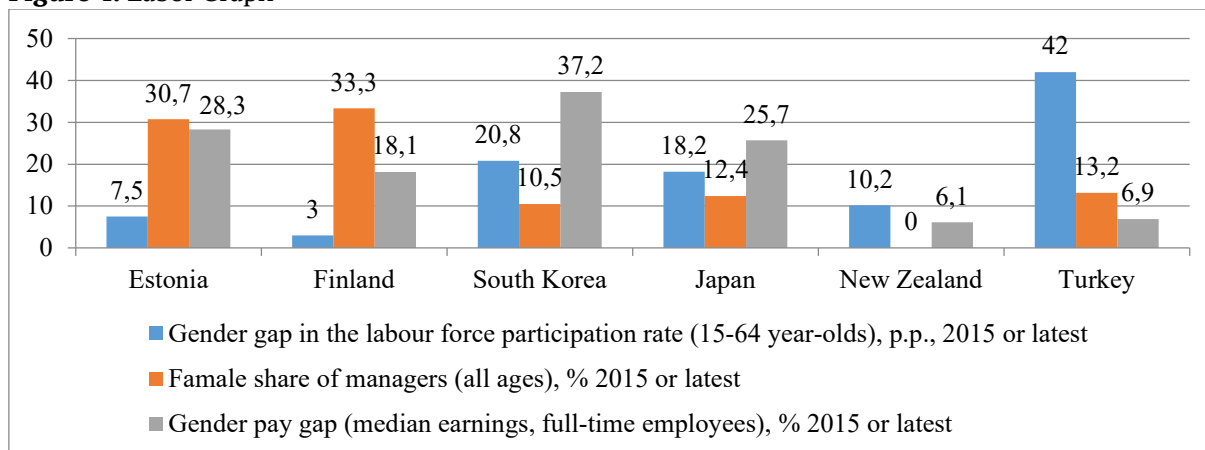
When examining the employment dimension of gender equality, it is necessary to consider the rate of female participation in the labor force, the female manager position and the gender wage gap in a country. Table 5 shows these rates of the countries.

**Table 5.** Labor Table

Country	Gender gap in the labour force participation rate (15-64 year-olds), p.p., 2015 or latest	Famale share of managers (all ages), % 2015 or latest	Gender pay gap (median earnings, full-time employees), % 2015 or latest
Estonia	7.5	30.7	28.3
Finland	3	33.3	18.1
South Korea	20.8	10.5	37.2
Japan	18.2	12.4	25.7
New Zealand	10.2	-	6.1
Turkey	42	13.2	6.9

Source: The Pursuit of Gender: An Uphill Battle, Employment. <http://www.oecd.org/gender/the-pursuit-of-gender-equality-9789264281318-en.htm>

When we examine the gender difference in participation rate of the workforce in Table 5, the gender gap with 42% in Turkey is considerably higher than the rate of other countries. When we look at the rate of female managers of the surveyed countries, Finland ranks first with 33.3%; Estonia ranks second with 30.7%, Turkey ranks third with 13%, Japan ranks fourth with 12.4% and South Korea ranks fifth with 10.5%. Table 5 uses the data of year 2015 or the most recent data. New Zealand's female manager share data could not be reached.

**Figure 4.** Labor Graph

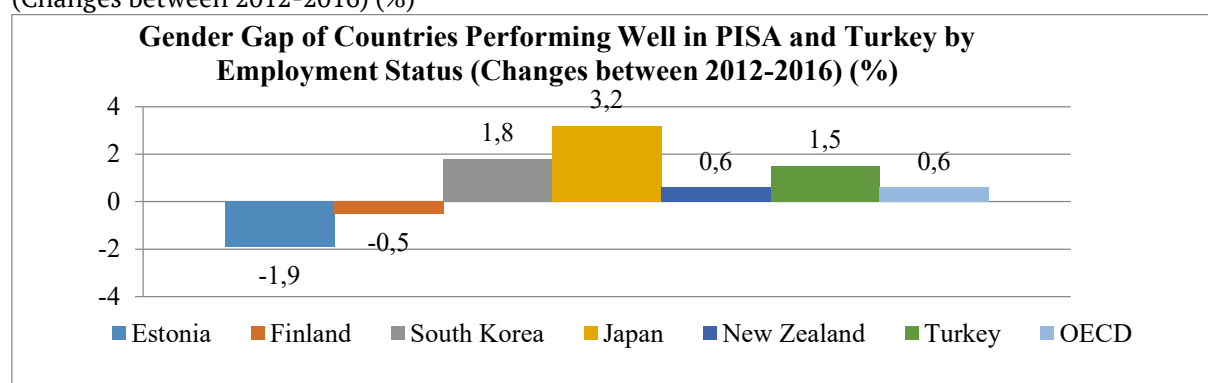
When we examine the gender wage gap; it is noteworthy that the wage gap in New Zealand is 6.1% and 6.9% in Turkey. Gender wage gap is 37.2% in South Korea, 28.3% in Estonia, 25.7% in Japan, and 18.1% in Finland. It is seen that the gender wage gap in Turkey is less compared to other countries (except New Zealand). As a result, it is observed that the gender gap of participation rate in labor force in Turkey is quite high, but the gender gap in wages is less compared to other countries (except New Zealand).

**Table 6.** Gender Gap of Countries Performing Well in PISA and Turkey by Employment Status

Country	2012 Year			2016 Year		
	Men	Women	Gender Gap	Men	Women	Gender Gap
Estonia	69.9	64.6	5.2	75.6	68.5	7.1
Finland	70.9	68.2	2.7	70.8	67.6	3.2
South Korea	74.9	53.5	21.4	75.8	56.2	19.6
Japan	80.3	60.7	19.6	82.5	66.1	16.4
New Zealand	77.4	66.8	10.6	80.7	70.7	10.0
Turkey	69.2	28.7	40.4	70.0	31.2	38.9
OECD	71.9	60.1	11.8	74.1	62.8	11.2

Source: The Pursuit of Gender: An Uphill Battle, figure 11.1 Access: <http://www.oecd.org/gender/the-pursuit-of-gender-equality-9789264281318-en.htm>

**Figure 5.** Gender Gap of Countries Performing Well in PISA and Turkey by Employment Status (Changes between 2012-2016) (%)



2012-2016 employment rates of the countries performing well with Turkey and the OECD average by gender is given in Table. According to the employment situation, a chart is prepared in order to make the gender gap between 2016 and 2012 clearer. According to the graph, gender gap has increased in Estonia and Finland according to the employment situation between 2016 and 2012. However, Estonia and Finland are the countries with the lowest gender gap according to employment status. In other countries, it is seen that there is a positive development and a decrease in gender gap. The change in gender gap in Japan is highest with 3.2%. The gender gap difference in the OECD average is 0.6%. Gender gap difference is 1.5% in the employment situation between 2012 and 2016 in Turkey.

**Table 7.** Gender Distribution Table with Employment of Countries Performing Well in PISA and Turkey by Economic Activity

Country	Agriculture		Industry		Services	
	Men	Women	Men	Women	Men	Women
Estonia	5.3	2.5	43.5	17.5	51.2	80.0
Finland	6.1	2.2	34.1	8.7	59.8	89.1
South Korea	5.6	5.7	32.6	13.7	61.8	80.6
Japan	3.9	3.2	33.8	14.6	62.3	82.3
New Zealand	9.1	4.6	30.3	9.7	60.4	85.5
Turkey	17.8	37.0	31.1	15.3	51.0	47.7
OECD	6.3	4.0	32.6	11.6	60.7	84.0

Source: The Pursuit of Gender: An Uphill Battle, figure 11.A.1 Access:

<http://www.oecd.org/gender/the-pursuit-of-gender-equality-9789264281318-en.htm>

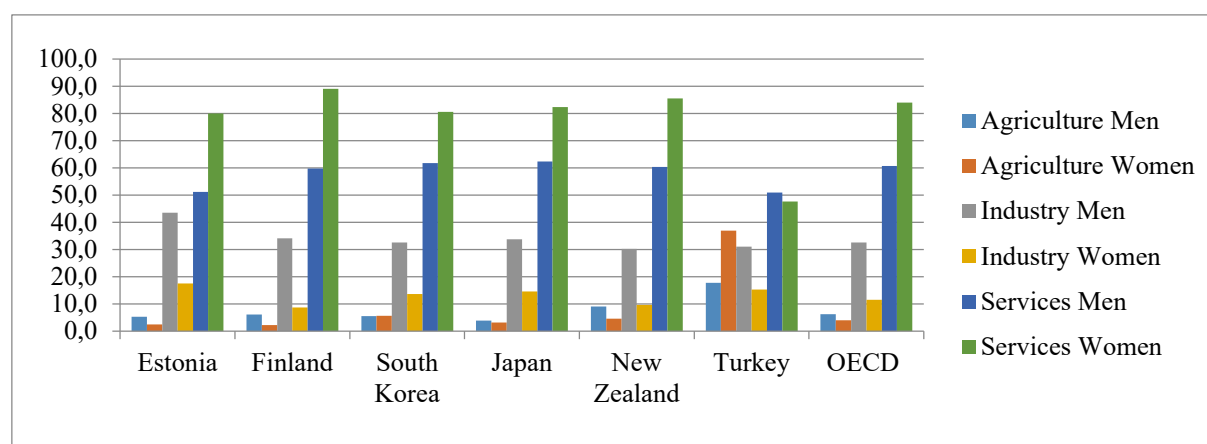
**Figure 6.** Gender Distribution Graph with Employment of Countries Performing Well in PISA and Turkey by Economic Activity

Table 7 shows employment situation in Turkey with successful countries in PISA under the headings of agriculture, industry and service activities by gender. When we examine the OECD average in female employment; women are employed with the rate of 4% in the agriculture sector, 11.6% in the industry, 84% in the service. As in the case in the OECD average, most of the women employed in successful countries in PISA are employed in the service sector. This rate is 80%. The rate of women in the service sector in Turkey is 47.7% and well below other countries and the OECD average.

Women are mostly employed in the agricultural sector in Turkey. The rate of women in the agricultural sector is 37%. This rate changes between 2.2% and 5.7% in the OECD average with other countries. When we examine the employment rate of women in the industrial sector, The OECD average is 11.6%. Estonia with rate of 17.5%, Turkey with the rate of 15.3%, Japan with rate of 14.6%, South Korea with the rate of 13.7% are above the OECD average. New Zealand is 9.7% and Finland is 8.7%, which are below the OECD average.

When we examine the differences between Turkey and other countries; the rate of women in the agricultural sector in Turkey is very high and almost twice the rate of men. While the rate of women in the service sector is high and the rate of men in the service sector is low in other countries, the rate of women employed in the service sector in Turkey is lower than that of men.



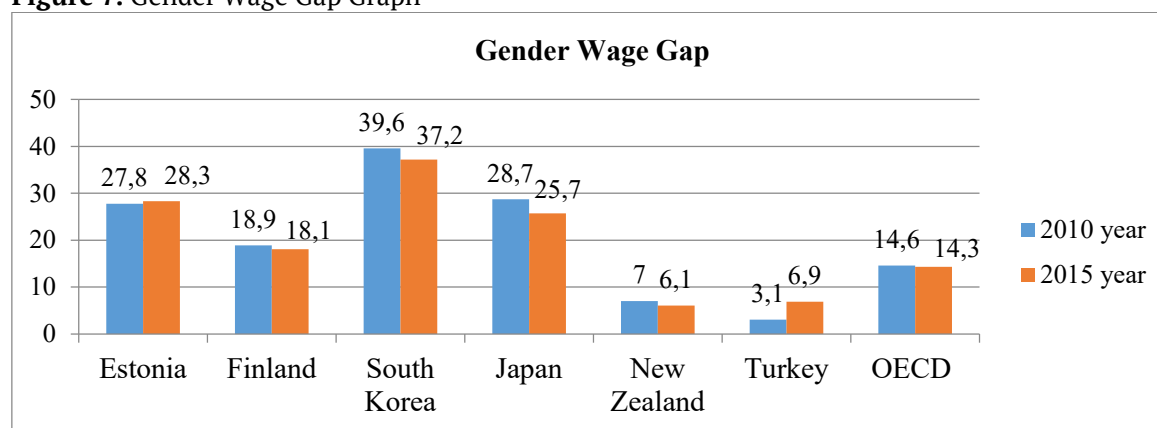
**Table 8.** Gender Wage Gap

Country	Gender Wage Gap	
	2010 year	2015 year
Estonia	27.8	28.3
Finland	18.9	18.1
South Korea	39.6	37.2
Japan	28.7	25.7
New Zealand	7	6.1
Turkey	3.1	6.9
OECD Ortalama	14.6	14.3

Source: The Pursuit of Gender: An Uphill Battle, Korea, figure 1.3.

Access: [http://www.oecd.org/korea/Gender\\_2017-KOR-en.pdf](http://www.oecd.org/korea/Gender_2017-KOR-en.pdf)

Table 8 shows gender wage gap between females and males of the countries and OECD average in 2010 and 2015. It is seen that the gap in wages in other countries except Estonia and Turkey has decreased in 2015.

**Figure 7.** Gender Wage Gap Graph

### 3.3. How is gender equality of Estonia, Finland, South Korea, Japan and New Zealand performing well in PISA with Turkey in the field of entrepreneurship?

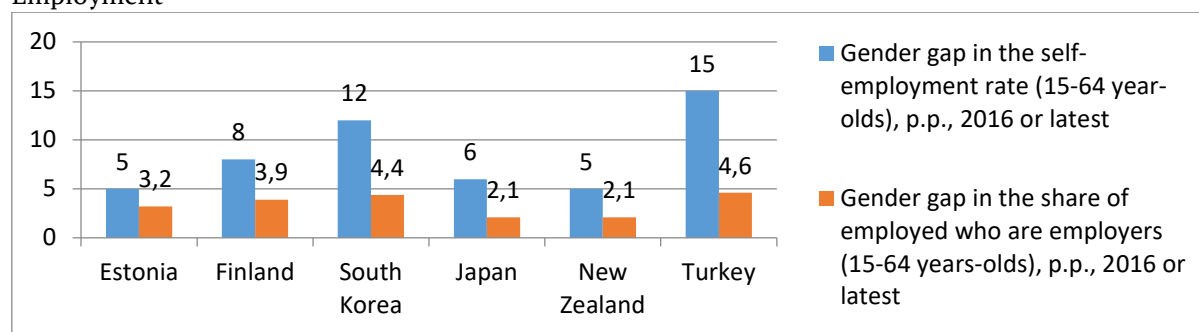
When we examine the gender gap at the rate of self-employed in Table 9, Turkey ranks first with the rate of 15% and South Korea ranks second with the rate of 12%. The rates of other countries are below 10%. When we examine the gender gap in the employment of the employers, it is seen that Turkey is still in first place with 4.6% and South Korea is in second place with 4.4%.

**Table 9.** Table of Gender Gap at the Self-employment Rate with Employers' Gender Gap in Employment

Country	Gender gap in the self-employment rate (15-64 year-olds), p.p., 2016 or latest	Gender gap in the share of employed who are employers (15-64 years-olds), p.p., 2016 or latest
Estonia	5	3.2
Finland	8	3.9
South Korea	12	4.4
Japan	6	2.1
New Zealand	5	2.1
Turkey	15	4.6

Source: The Pursuit of Gender: An Uphill Battle, Entrepreneurship.

Access: <http://www.oecd.org/gender/the-pursuit-of-gender-equality-9789264281318-en.htm>

**Figure 8.** Graph of Gender difference at the Self-employment Rate and Employers' Gender Gap in Employment

### 3.4. What are the similarities and differences between Estonia, Finland, South Korea, Japan, New Zealand and Turkey in terms of gender equality in the field of education, employment and entrepreneurship?

\* Enrollment rate of women in preschool education and in tertiary education is low in Turkey compared to other successful countries.

\* The rate of women graduates in science, mathematics and computing in Turkey is higher than in other countries. When we consider the rates of women employed in industry sector, Turkey ranks second after Estonia.

\* The enrollment rate of women in tertiary education is higher than men in Estonia, Finland, South Korea, Japan, New Zealand, which are successful in PISA. However, the enrollment rate of women in tertiary education is lower than men.

\* Wage gap between men and women in Turkey is less than other countries (except New Zealand).

#### Recommendations for Turkey

✓ New studies should be carried out to increase the enrollment rate in pre-school education in Turkey.

✓ 50% of women in Turkey who have graduated from tertiary education are graduates in science, mathematics and computing. The rate of women employed in the industrial sector in Turkey is 15.3%. This rate is lower in other countries (except Estonia). Necessary measures should be taken to increase the employment of women in the industrial sector.

✓ The rate of women working in the agricultural sector in Turkey is higher than in other countries. In fact, the rate is even greater than men who are employed in the agricultural sector in Turkey.

✓ Necessary measures should be considered so that women have opportunities to be entrepreneurs in the agricultural sector in Turkey where gender gap exists about entrepreneurship.

#### 4. References

Maya, I. (2016). Uluslararası öğrenci değerlendirme programı sonuçlarına göre ülkelerin başarılarını etkileyen göstergeler. *International Periodical for the Languages, Literature and History of Turkish*, 11(3), 1665-1684.

MEB. PISA, Türkiye. *PISA nedir?* Retrieved January 23, 2018 from [http://pisa.meb.gov.tr/?page\\_id=18](http://pisa.meb.gov.tr/?page_id=18)

MEB. (2015). PISA Türkiye (2012) Ulusal Nihai Rapor. Retrieved January 21, 2018 from <https://drive.google.com/file/d/0B2wxMX5xMcnhaGtnV2x6YWsyY2c/view>

MEB. (2016). PISA 2015 Ulusal Raporu. Retrieved December 18, 2017 from [http://pisa.meb.gov.tr/wp-content/uploads/2014/11/PISA2015\\_UlusalRapor.pdf](http://pisa.meb.gov.tr/wp-content/uploads/2014/11/PISA2015_UlusalRapor.pdf)

Ministry of Family and Social Policy General Directorate on the Status of Women. (2017).

*Women in Turkey*, Ankara: Retrieved January 23, 2018 from

<http://kadininstatusu.aile.gov.tr/uygulamalar/turkiyede-kadin>

Ministry of Family and Social Policy General Directorate of Women's Status. (2012). Directorate General of Women's Status. Ankara.

OECD. (2017). *The pursuit of gender equality an uphill battle*. Retrieved January 13, 2018 from <http://www.oecd.org/publications/the-pursuit-of-gender-equality-9789264281318-en.htm>

Tastekin, S. (2018). *Ogretmenlerin mesleki gelism uygulamalari acisindan PISA'da basarili bazi ulkeler ile Turkiye'nin karsilastirilmesi* (Yayimlanmamis yuksek lisans tezi). Canakkale Onsekiz Mart Universitesi, Egitim Bilimleri Enstitusu, Canakkale.

World Development Indicators. (2016), *The little data book on gender*. Washington: The World Bank. Retrieved February 11, 2018 from <https://data.worldbank.org/products/data-books/little-data-book-on-gender>, 79-83-113-119-156-213.

Yilmaz, A. (2017). *Egitim denetimi sistemleri bakimindan Turkiye ile PISA'da basari gosteren bazi ulkelerin karsilastirilmesi* (Yayimlanmamis yuksek lisans tezi). Canakkale Onsekiz Mart Universitesi, Egitim Bilimleri Enstitusu, Canakkale.

<http://www.oecd.org/korea/Gender2017-KOR-en.pdf> Retrieved March 18, 2018 from.

# **Examination Of The Reasons For The Preference Of Teacher Candidates For The Mathematics Teaching Program: Aydin Case Abstract**

Nesrin Ozsoy, Gokhan Kinali, Yildiz Akkaya, Merve Umurbek

## **1. INTRODUCTION**

It is very difficult to define mathematics and to express it in a closed form. It is a continuous developing work area of which application and use is large. In a simple way, an introduction can be made to the field of mathematics as a way of expressing the mental activities that people use for meaning and comprehension by using abstract concepts in a universal language and in accordance with the rules of this language (Altun, 2006). All the mathematical expressions we use are based on abstract concepts and the rules that do not contradict themselves. Mental activities in the language of mathematics and understanding and using this language is an art. While trying to make sense of abstract mathematical concepts such as numbers, geometric shapes and the relations between these concepts, mathematics provides the skills to discover patterns and solve problems due to its nature. Mathematics plays an important role in understanding the events and situations in all our lives, finding solutions according to the problems encountered and the discoveries made by humanity in the field of science and technology.

New approaches in education have started to be adopted. In these approaches, it is expected that a healthy communication between the teacher and the students will be established and students will actively participate in the classes. In constructivist approach, a teacher is expected to be open-minded, self-improving, to take into account individual differences among students, to be expert in the field of work, not only to provide ready-made knowledge to students but also to prepare appropriate learning environments, to interact with their students and even learn with them (Selley, 1999; 22 ). The perspectives of teacher candidates to their occupation play an important role in training qualified teachers. Candidates who want to do teaching profession should firstly love the profession of teaching and gain their self-confidence about what they can teach. For this reason, the reasons of the students who choose the teaching profession and their expectations' meeting level for this program are important. In this study, it is thought that it will be useful to shape teacher training process by taking into consideration the reasons of teacher candidates to choose mathematics teaching program and their expectations from the program.

## **2. METHOD**

### **Research Design**

To reveal the reasons of teacher candidates who prefer elementary mathematics teaching program their expectations from the program, whether their expectations are met or not and how they want to be a teacher have been examined by special case study method by using qualitative pattern.

This research is a qualitative research and it is a special case study as the opinions, attitudes and expectations of the people in the sample have been tried to be determined. It provides the opportunity to concentrate on the ordinary situation in special case studies (Cepni, 2007).

### **Sample**

The research has been made with the volunteer 66 teacher candidates who are on the first and second class in elementary maths teacher program in Adnan Menderes University in 2017-2018 academic year fall semester. The demographic data of the teacher candidates in Adnan Menderes University is given in Table.1

**Table 1. Adnan Menderes University Demographic information of the students, the schools they graduate and the Placement Score**

CATEGORIES	SUB CATEGORIES	FREQUENCY	PERCENT
GENDER	WOMAN	56	85
	MALE	10	15
GRADUATED SCHOOL TYPE	SCIENCE HIGH SCHOOL	1	2
	ANATOLIAN TEACHER HIGH SCHOOL	16	24
	ANATOLIAN HIGH SCHOOL	30	45
	PRIVATE HIGH SCHOOL AND BASIC HIGH SCHOOL	18	27
	VOCATIONAL AND TECHNICAL HIGH SCHOOL	1	2
PROGRAM PLACEMENT POINTS	350 POINTS	2	3
	350-360	10	15
	360-370	12	18
	370-380	17	26
	380-390	12	18
	390 POINTS OVER	6	9
	NOT REMEMBER	7	11

As it is seen clearly, Adnan Menderes University teacher candidates are mostly female (85%), a portion of teacher candidates is The Anatolia and Anatolian Teacher High School graduates (69%) and there are also 18 (27%) teacher candidates who graduated from private schools and basic school. Only one teacher candidate graduated from science high school and one from vocational high school. It is also clear that 3% of teacher candidates' placement score are under 350 points, 15% between 350-360 points, 18% between 360-370 points, 26% between 370-380 points, 18% between 380-390 points and only 6 teacher candidates got over 390 points. There are also 7 teacher candidates who cannot remember their placement score.

#### **Data collection tool**

The data obtained from the research has been collected through a semi-structured form with open-ended questions directed to the teacher candidates as "Why did you choose primary mathematics teaching program?", "What are your expectations from the mathematics teaching program", "Did the program meet your expectations?" and "How do you want to be a teacher?" It has been stated in the instruction section of the distributed form that the answers of the questions the teacher candidates answered in the form would be kept confidential and the answers would not be used for any purpose other than the research. Thus, teacher candidates have been asked to give sincere answers. In addition, the questions in the semi-structured form used in the research which Incikabi, Mercimek, Biber, Serin

conducted on 'Why am I in Elementary Mathematics Teacher Education Program?' in Kastamonu University in 2013 have been benefited.

### Analysis of data

Content analysis has been used in the analysis of the data obtained in the qualitative pattern study. The results of the analysis have been collected under category and subcategory. As qualitative studies are not concerned with generalization, the results are limited only to teacher candidates in the research. It is important that the validity and reliability of the results in qualitative researches should be examined as deeply as possible and tried to be provided by direct submission (Yildirim and Simsek 2013). For this reason, the answers of the teacher candidates have been included in the research where necessary. The opinions of two education experts have been taken into consideration and they have been divided into categories and sub-categories.

### 3. Findings and Comments

In order to understand the expectations of teacher candidates from the elementary mathematics teaching program better, some of their answers have been quoted.

*Examining the reasons of preference of primary mathematics teaching program according to gender, type of graduation and placement scores*

**Table 2. Examining the reasons for choosing the program according to gender in Adnan Menderes University**

Gender	Girl		Male	
	Frequency (f)	Percent (%)	Frequency (f)	Percent (%)
Future anxiety	17	19	7	47
Predisposition to Maths	28	31	5	33
Predisposition to profession	25	28	3	20
Obligation due to placement score	20	22	0	0

The reasons of preference according to gender factor have been examined under 4 categories. These categories are future anxiety, predisposition to Maths, predisposition to profession and the necessity due to score points. The preference in terms of predisposition to Maths is 31% for girls and 33% for males and it can be said that there is no significant difference according to gender. Future anxiety among male teacher candidates (47%) is higher than female teacher candidates (19%). The predisposition to the profession has been observed in females (28%) and males (20%). In addition, the reasons for preferring due to placement points have been found only in the answers of female teacher candidates. The answers like "I have chosen being teacher as I love teaching" have been categorized in predisposition to profession, "I have chosen being teacher as I love Maths" have been categorized in predisposition to Maths, "The reason why I have chosen mathematics as a department is that it is the closest to my score" has been categorized in obligation due to placement score and "it is easier to be assigned" have been categorized in future anxiety.

**Table 3. Examining the reasons for choosing the program according to graduated school in Adnan Menderes University**

Graduated High School	Science High School		Anatolian Teacher High School				Anatolian High School		Private high school		Vocational and Technical High School	
	f	%	F	%	f	%	f	%	f	%		
	<b>Future anxiety</b>	1	100	4	15	14	30	5	22	0	0	
<b>Predisposition to Maths</b>	0	0	9	35	17	37	5	22	1	50		
<b>Predisposition to Profession</b>	0	0	8	31	12	26	5	22	0	0		
<b>Obligation due to placement score</b>	0	0	5	19	3	7	8	34	1	50		
<b>Total</b>	100		100		100		100		100		0	

While the reasons of teacher candidates' preferences for primary mathematics teaching program according to the high schools they graduated from have been taken into consideration, it can be seen that the candidate who graduated from Science High School preferred to attend the school due to his/her future anxiety. For Anatolian Teacher High School graduates, future anxiety is 15%, predisposition to Maths is 35%, predisposition to occupation is 31% and point requirement is 19%. For Anatolian High School graduates, future anxiety is 30%, predisposition to Maths is 37%, predisposition to occupation is 26% and point requirement is 7%. For private high school graduates, future anxiety is 22%, predisposition to Maths is 22%, predisposition to occupation is 22% and point requirement is 34%. One of the 2 students who graduated from vocational high school preferred the program as he/she is tend to Maths and the other one preferred due to the requirement of point.

**Table 4. Examining the reasons for choosing the program according to placement points in Adnan Menderes University**

Placement Ratings	Under 350 points		350- 360		360- 370		370- 380		380- 390		Over 390 points	
	f	%	f	%	f	%	f	%	f	%	F	%
<b>Future anxiety</b>	0	0	7	44	4	29	3	11	5	28	0	0
<b>Predisposition to Maths</b>	1	33	4	25	6	43	12	43	4	22	1	20
<b>Predisposition to Profession</b>	1	33	4	25	2	14	7	25	4	22	4	80
<b>Obligation due to placement score</b>	1	33	1	6	2	14	6	21	5	28	0	0
<b>Total</b>	100		100		100		100		100		100	

As it can be seen that the reasons for Adnan Menderes University teacher candidates with a placement score of less than 350 points are predisposition to Maths (33%), predisposition to profession (33%) and

## Examination Of The Reasons For The Preference

obligation due to placement score (33%). The reasons for the preference of the students in the 350-360 points are future anxiety (44%), predisposition to Maths (25%), predisposition to the profession (25%), and the score requirement (6%). The reasons for preference of students in the 360-370 points are future anxiety (29%), predisposition to Maths(43%), predisposition to the profession (14%) and the score requirement (14%). The reasons for preference of students in the range of 370-380 points are the future anxiety (11%), predisposition to Maths (43%), predisposition to the profession (25%) and the score requirement (21%). The reasons for preference of the students in the 380-390 points range are future anxiety (28%), predisposition to Maths (22%), predisposition to the field (22%) and the score requirement (28%). The reasons for the choice of students over 390 points have been determined as predisposition to Maths (20%) and predisposition to the profession (80%).

**Table 5. Examining the teacher candidates' expectations of the program according to gender in Adnan Menders University**

Gender	Girl		Male	
	F	%	f	%
Field knowledge	33	42	3	60
Pedagogical Knowledge	44	56	2	40
Social activities	2	2	0	0
<b>Total</b>		<b>100</b>		<b>100</b>

Elementary mathematics teacher candidates' expectations from the program have been analysed in 3 categories as field knowledge, pedagogical knowledge and social activities. 42% of female teacher candidates have expectations for field knowledge, 56% for pedagogical knowledge and only 2% for social activities. For male teacher candidates, it is 60% for field knowledge and 40% for the category of pedagogical knowledge. The expressions "I want to have more equipment in teaching and graduate as a fully-equipped teacher" and "I prefer learning teaching to learning mathematics" have been coded as field information (B34). The statement "Providing a permanent and enjoyable education environment by enriching the course with various activities, not just as a course" has been coded as pedagogical knowledge and social activity expectations (B35).

**Table 6. Examining the teacher candidates' expectations of the program according to graduated school in Adnan Menderes University**

Expectations from Elementary Mathematics Education Program	Science High School		Anatolian Teacher High School		Anatolian High School		Private high school		Vocational Technical High School	
	f	%	f	%	f	%	f	%	f	%
Field Knowledge	1	50	12	46	18	50	11	48	1	50
Pedagogical Knowledge	1	50	14	54	17	47	10	43	1	50
Social activities	0	0	0	0	1	3	2	9	0	0
<b>Total</b>		<b>100</b>		<b>100</b>		<b>100</b>		<b>100</b>		<b>100</b>



When the expectations of mathematics teacher candidates have been examined according to the type of high school graduates, it is seen that the students who graduated from Science High School, Anatolian Teacher High school and Vocational and Technical High School types have expectations for pedagogical knowledge and field knowledge. It has been analysed that expectations for field knowledge of Science High School graduates is 50%, Anatolian Teacher High School is 46%, Anatolian High School is 50%, Private High School is 48% and Vocational Technical High School is 50%. Expectations for pedagogical knowledge of Science High School graduates is 50%, Anatolian Teacher High School is 54%, Anatolian High School is 47%, private High School is 43% and Vocational Technical High School is 50%. It can also be stated that the teacher candidates who graduated from Science High School, Anatolian Teacher High School and Vocational Technical High have not mentioned any expectations for social activities.

**Table 7. Examining the teacher candidates' expectations of the program according to placement score in Adnan Menderes University**

Expectations from Elementary Mathematics Education Program	Under 350 Points		350-360		360- 370		370-380		380-390		Over 390	
	f	%	f	%	f	%	f	%	f	%	f	%
Field Knowledge	1	50	6	50	5	50	15	50	12	50	4	50
Pedagogical Knowledge	0	0	5	42	5	50	14	47	11	46	4	50
Social activities	1	50	1	8	0	0	1	3	1	4	0	0
<b>Total</b>		<b>100</b>		<b>100</b>		<b>100</b>		<b>100</b>		<b>100</b>		<b>100</b>

According to the placement scores of teacher candidates, it is seen that teacher candidates focus on knowledge of the field and pedagogical knowledge. The students who have a score of under 350 points have expectations for field knowledge 50% and social activities 50%. The students who have a score of between 350 and 360 points have expectations for field knowledge 50%, for pedagogical knowledge 42% and social activities 8%. The students who have a score of between 360 and 370 points have expectations for field knowledge 50% and for pedagogical knowledge 50%. The students who have a score of between 370 and 380 points have expectations for field knowledge 50%, for pedagogical knowledge 47% and social activities 3%. The students who have a score of between 380 and 390 points have expectations for field knowledge 50%, for pedagogical knowledge 46% and social activities 4%. The teacher candidates with a placement score of over 390 have expectations for field knowledge (50%) and pedagogical knowledge 50%.

*Did your primary mathematics teaching program meet your expectations? Examining the answers of the teacher candidates according to gender and type of high school graduated.*

**Table 8. Did Adnan Menderes University's Elementary Mathematics Teacher Program meet your expectations? Examination of the answers of teacher candidates according to gender**

Did the program meet your expectations?	Girl		Male	
	f	%	f	%
Yes	24	43	2	22
No	6	11	0	0
Partially	11	20	0	0
Too early	15	26	7	78
<b>Total</b>		<b>100</b>		<b>100</b>

Did the program meet your expectations? As it is seen on the table above, the answers of female teacher candidates are “yes” 43%, “no” 11%, “partially” 20% and early to answer 26%. Male teacher candidates' answers are “yes” 22% and early to answer 78%. As the teacher candidates are on the first and second class, the rate of students who think it is too early to answer is high.

**Table 9. Did Adnan Menderes University's Elementary Mathematics Teacher Program meet your expectations? Examination of the answers of teacher candidates according to high school graduated**

Did the program meet your expectations?	Science High School		Anatolian Teacher High School		Anatolian High School		Private High School		Vocational Technical High School	
	f	%	f	%	f	%	f	%	f	%
Yes	0	0	4	25	11	38	5	28	0	0
No	1	100	1	6	1	3	3	17	0	0
Partially	0	0	2	13	6	21	4	22	1	100
Too early	0	0	9	56	11	38	6	33	0	0
<b>Total</b>		<b>100</b>		<b>100</b>		<b>100</b>		<b>100</b>		<b>100</b>

Did the program meet your expectations? When the answers of the students have been examined, the expectations of the student graduated from Science High School have not been met. The answers of the students who graduated from Anatolian Teacher High School are “yes” 25%, “no” 6%, “partially” 13% and “early to answer” 56%. The answers of the students who graduated from Anatolian High School are “yes” 38%, “no” 3%, “partially” 21% and “early to answer” 38%. The answers of the students who graduated from Private School are “yes” 28%, “no” 17%, “partially” 22% and “early to answer” 33%. It is also seen that the expectations of the student who graduated from vocational and technical high school have been partially met.

**Table 10. How would you like to be a teacher? Adnan Menderes University, Examination of the answers of teacher candidates according to high school graduated**

How would you like to be a teacher?	Science High School		Anatolian Teacher High School		Anatolian High School		Private high school		Vocational Technical High School	
	f	%	F	%	f	%	f	%	f	%
<b>Role model</b>	1	50	14	47	19	40	16	47	1	50
<b>Qualified (Successful)</b>	1	50	14	47	22	46	16	47	1	50
<b>Fair, Contemporary Idealist</b>	0	0	2	6	7	14	2	6	0	0
<b>Total</b>		100		100		100		100		100

How do you want to be a teacher? When the answers given to the question have been examined according to the type of high school, it is understood that teacher candidates who graduated from Science High School want to be both a role model and a qualified teacher. A large number of Anatolian Teacher High School graduates want to be a role model and a qualified teacher. 6% of students want to be fair, contemporary and idealist. A large number of Anatolian High School graduates want to be a role model and a qualified teacher. 14% of students want to be fair, contemporary and idealist. A large number of Private School graduates want to be a role model and a qualified teacher and very few want to be idealistic teachers (6%). Teacher candidates who graduated from Vocational and Technical High School want to be both a role model and a qualified teacher.

#### 4. Discussion and Conclusion

In this study, it has been tried to determine the reasons of the teacher candidates who are attending the first and second class in Adnan Menderes University for their preference, their expectations and whether the expectations are met or not according to gender, placement score and type of school they graduated. Generally, it is seen that girls prefer this program more than males. According to the findings obtained from Adnan Menderes University female teacher candidates, it can be seen that they prefer the program respectively as they love mathematics (Disposition to Field), have interest in teaching profession (Disposition to Profession) and have points for the program (Score obligation). The reasons such as its being a promising job and its advantages (Future Anxiety) are the last reasons for preference. When we look at the results of the female students in two universities, it is understood that they prefer as they love mathematics lesson and the profession of teaching. The reason "future anxiety" takes the first place among the reasons for male teacher candidates in Adnan Menderes University. It has been determined that male teacher candidates who are studying in Adnan Menderes University have not preferred the program because of the score requirement. Considering the reasons why the candidates prefer the program in Adnan Menderes University, the student who is a graduate of Science High School has future anxiety. In addition, when we look at the placement scores of the teacher candidates studying in Adnan Menderes University, it is seen that there is an accumulation between 360-380 points. Furthermore, it is observed that there is no expectation of social activity from the program. When teacher candidates' expectations from the program according to the types of schools they graduated from are considered, pedagogical knowledge is the first place among the expectations of the Anatolian Teacher High School graduates who are studying in Adnan Menderes University. The ranking of other high school graduates is in the form of field knowledge, pedagogical knowledge and social activity. Students of vocational high schools do not expect social activities from the program. University are listed as field knowledge, pedagogical knowledge and social activity respectively. In

addition, private high school and vocational high school graduates do not expect social activities from the program. When the teacher candidates' expectations from the program according to the placement scores in both university, they are in the form of field knowledge, pedagogical knowledge and social activity in all point ranges. Only teacher candidates who received a score of 360-370 and a score higher than 390 points do not expect social activities in Adnan Menderes University

Did the program meet your expectations? According to the type of high school graduated from, in Adnan Menderes University, the expectations of the student graduated from Science High School have not been met. The answers of the students who graduated from Anatolian Teacher High School are "yes" 25%, "no" 6%, "partially" 13% and "early to answer" 56%. The answers of the students who graduated from Anatolian High School are "yes" 38%, "no" 3%, "partially" 21% and "early to answer" 38%. The answers of the students who graduated from Private School are "yes" 28%, "no" 17%, "partially" 22% and "early to answer" 33%. It is also seen that the expectations of the student who graduated from vocational and technical high school have been partially met.

As a result, in order to educate a qualified teacher, it is important to determine the reasons of preferences of teacher candidates, what their expectations are and whether their expectations are met or not (Tataroglu, Ozgen, Alkan, 2011).

According to the results of our research, it is understood that most of the teacher candidates come to the elementary mathematics teaching program willingly and fondly. Education faculties should have more responsibilities to train qualified teachers. On the other hand, it should be ensured that candidates with qualifications required by the profession be selected to the faculties of education. Because teaching is a profession that guides our future, has social responsibility and needs to be consciously chosen (Incikabi, Biber, Mercimek, 2016). To generalize, this study should not limited to a single university and should be applied in universities with more students.

## 5. References

- Altun, M. (2006). *Developments in mathematics teaching*. Uludag University Education Faculty Journal , 19 (2).
- Attwood, TK, Flower, DR, Lewis, AP, Mabey, JE, Morgan, SR, Scordis, P., & Wright, W. (1999). *PRINTS prepares the new millennium*. Nucleic Acids Research, 27 (1), 220-225.
- Biber, A. C. (2013). *Investigating Teacher Candidates' Satisfaction Levels About Elementary Mathematics Education Undergraduate Program : The Case of Kastamonu University Faculty of Education*. Kastamonu Education Journal, 21 (3), 1253-1270
- Boz, Y. and Boz, N. (2008). *The reasons of being a teacher of chemistry and mathematics teachers*. Kastamonu Education Journal, 16 (1), 137-144.
- Cermik, H., Dogan, B. ve Sahin, A. (2010). *The reasons of preferences of class teacher candidates* Pamukkale University Faculty of Education Journal, 28: 201-212.
- Dogan, T. and Coban, AE (2009). *An examination of the relationship between the attitudes of the faculty of education students and their anxiety level*. Journal of Education and Science. 34, 153.
- Ekici, F. (2014). *Examining the attitudes of teacher candidates towards teaching profession in terms of various variables (Istanbul Sabahattin Zaim University Sample)*. Journal of International Social Research, 7 (35), 658-665
- Ekinci, CE and Burgaz, B. (2007). *Expectation and Satisfaction Levels of Hacettepe University Students About Some Academic Services*. Hacettepe University Journal of Education Faculty, 33: 120-134.
- Haciomeroglu, G. and Taskin, C. S. (2010). *Attitudes of Teacher Candidates in Science Education and Secondary School Science and Mathematics Education Department Related to Teaching Profession*. Ahi Evran University Journal of Education Faculty, 11 (1): 77-90.
- Incikabi, L., Mercimek, O. and Pepper, A.C. (2016). *A research on the reasons and expectations of primary mathematics teacher candidates' program preference*. Adiyaman University Institute of Social Science Journal, 22: 165-188.
- Korkut-Owen, F., Kepir, D.D, Ozdemir, S., Ulas, O. and Yilmaz, O. (2012). *Reasons of University Students for Choosing Program*. Mersin University Faculty of Education Journal, 8 (3), 135-151.

- Ozen, R., Yildiz, S. and Yildiz, K. (2013). *Professional anxiety levels of teacher candidates*. Journal of International Education Programs and Teaching Studies, 3 (6), 21-30
- Ozsoy, G., Ozsoy, S., Ozkara, Y. and Memis, A.D (2010). *Factors Affecting Teacher Candidates to Prefer Teaching Profession*. Primary Online, 9 (3): 910-921.
- Serin, M.K, Gunes, A.M and Degirmenci, H. (2015). *The Relationship between the Attitudes of Primary School Students' Attitudes towards Teaching Profession and the Anxiety Levels of Profession*. Cumhuriyet International Journal of Education, 4 (1), 21- 34
- Sara, P. and Kocabas, A. (2012). *Classroom teacher candidates' reasons for their choice of classroom teaching and their opinions about the education they receive*. Turkish International Journal of Special Education and Guidance & Counseling, 1 (2), 8-17
- Tataroglu, B., Ozgen, K. and Alkan, H. (2011). *Preference Reasons of Maths Teacher Candidates and Their Expectations*. 2nd International Conference on New Trends in Education and Their Implications. Ankara: Political Bookstore
- Ubuz, B. and Sari, S. (2008). *Preference Reasons of Classroom Teacher Candidates*. Pamukkale University Faculty of Education Journal, 24 (2): 113-119.
- Uras, M. and Kunt, M. (2006). *Teachers Candidates' Expectations from Teaching Profession and Their Hoping Level of Meeting Expectations*. Pamukkale University Journal of Education Faculty, 19 (1): 71-83.
- Yilmaz, N., Dogan, N. (2015). *Factors Affecting Profession Choices of Primary Mathematics Teachers: Hacettepe University Case*. Abant Izzet Baysal University Faculty of Education Journal, 15 (1), 405-421.

# What values should be taught? Measuring the Perceptions of High School Teachers on Values Education

Pervin Oya Taneri, Mehmet Mahsum Akgunduz

## 1. Introduction

Values are the principles that help individuals in a society to live together in peace and harmony. Although, values are changing over time, and differ from society to society, they are inevitable aspects of shared life. Whenever social conflicts, corruptions, crime rates, violence, immoralities, and frauds increase, values education becoming the primary debate issue in society. Afterwards, educators, politicians, sociologists, psychologists, lawyers, in short, all social scientists and ordinary citizens begin to think and discuss about lost values. While the justified reasons regarding the erosion of values have changed historically, quick technological changes, social movements, and globalization are the most frequently mentioned causes. Put another way, following the discussion of the disappearance of values, the necessity of values education has emerged as an urgent agenda.

The purpose of this study is to reveal the perceptions of high school teachers on values education. The teachers were asked whether there is a need values education, what values should be taught (e.g. aims and content of values education curricula), which instructional methods should be used, and how the success of students measured. The following research questions were answered in determining the route of the research:

1. What do the teachers think about whether there is any need for values education in the society?
2. What values should be taught in the schools (e.g. aims and content of values education curricula),
3. Which instructional methods should be used in values education?
4. How the success of students measured in values education?

## 2. Literature Review

### 2.1. Values education

Values education refers all sources of activities in schools in which students learn or develop values and ethics (Halstead, 1996; Lovat, 2011; Powney, Cullen, Schlapp, Johnstone, & Munn, 1995; Taylor, 1994). Since schools are not unresponsive to and free from values, in order to help learners to adapt the changes in their surroundings, it is required the schools to change the learners' behaviors and/or generate new behaviors. Today, values education is a controversial issue both in Turkey and in the world. The intense social changes, international instability, technological developments and intellectual discomfort reason deep changes in values around the world. That is to say, the values of society are greatly affected by sociological, technical, political and economic changes. Those constituents have mutual effects on each other, such as the increase in the use of internet cause changes in the family structures and role models of society. Similarly, political and economic changes have a great impact on patterns of work, unemployment and leisure, geographical mobility, cultural diversity and continuing gender, and ethnic inequalities.

Given that if values education ignored by the society, it is unavoidable the media turn into values generating mechanism and direct the structure of society. Specifically, when individuals feel alienation and pointless, they heavily depend on media (Aspin & Chapman, 2007). Therefore, in order to overcome those problems there is a need for values education. One of the discussions on this issue is that either values education is integrated into the present curricula or should it be given as a separate course. Another dilemma 'who', 'where', 'when', 'how' and 'whose values' are taught has emerged when it was decided that values education integrated in school curricula.

The literature asserted that in many of the countries values education generally integrated into other subjects in the school curricula especially social studies and religion courses, rather than as a separate subject. For example, the findings of a study which compared Turkish and Swedish schools revealed that neither in Turkey nor in Sweden schools have a specific values education course (Thornberg & Oguz, 2013). There is a no consensus on the content of values education course. Some says in literature moral and religious values should be emphasized. On the other hand, other researchers prioritizing scientific, secular, aesthetic, and universal values in education. More others claimed that initiative, competitive, hedonistic, and individualistic values are basic values. It is expected that in the future there will be more debate on this issue among educators, researchers, politicians, religious people, philosophers, and so on.

## **2.2. Different Approaches to Values Education**

There is conflict of ideas, not agreement in the field of values education, and political influences in values education must be accepted with severe argument (Department of Education, Science and Training, 2005). Therefore, the approaches to values education can be classified in different ways.

The first classification is traditional and progressive or constructive approach of teaching values. The traditional approach is content-oriented and culture-centered. This approach emphasizes conveying certain moral truths, codes of conduct, and unchanging truths; it utilizes moral dogmatism and indoctrination methods such as rewards and punishments. This approach adopts an up-down process that conveys or suggests a moral code through external incentives, direct instruction, and consistent modeling, from the community to the learners (Durkheim, 1961; Jones, 2009). On the other hand, progressivist or constructivists approach is process-oriented and focuses on developing the student's autonomous capacity to reason or deliberate in a morally principled way (Solomon, Watson & Battistich, 2001). This approach suggests child-centered and indirect approaches. Specifically, it stresses individualism and focus less on exhortation and lecture and more on school atmosphere and service learning (Leming, 1997). Therefore, open-mindedness, holistic moral development, and interactive learning are very important in values education.

According to the second classification, values are taught in the direct, the integrated, and the holistic approach. In direct approach, just like other courses, values education has a planned curriculum. Content of values education curriculum can be organized around specific values such as virtuousness, trust, generosity, honesty, justice, respect, and accountability, as well as to tackle a precise problem faced at school or in society. The integration approach in values education is the development of values through teaching-learning activities in different areas of learning; it does not mean quoting and discussing a value. The existing curriculum provides countless opportunities for students to think about values. That is, firstly the values to be developed within the course are determined; then the values are integrated with the concepts of that lesson. The integration of values education leads to a personal sense of what is taught to students in the class. The holistic approach is to integrate value education into all school experiences and activities. The realization of this integration depends on the full reconciliation of teachers and school staff about the importance of values education. It also requires the appreciation of values as much as academic knowledge. That is, affective domain skills should be considered as important as cognitive skills. School climate and activities should emphasis on building good relationships students, employees, parents and society in general. (Kumta, 2013; Manichander, 2016).

## **3. Method**

For the purpose of this study, qualitative research approach has been preferred. Efforts were made to disclose the views and perceptions about values education, and it emphasizes on the analysis of qualitative data.

### 3.1. Participants

The participants of this study were 14 public school teachers from public high schools. Regarding the gender, 6 are males, while 8 are females. The participants' ages ranged from 31 to 56 years. Professional experience of participants is in the range of 8-22 years. Participants' subject matter: Philosophy, History, Geography, Mathematics, Physics, Visual Arts, Physical Education, English and Turkish. The participant teachers were working in different types of high school teachers such as Anatolian Imam Hatip High Schools, Fine Art High Schools, Science High Schools, and Social Sciences High Schools.

### 3.2. Data Collection and Analysis

The data were collected by an open-ended questionnaire. The questions are focused on revealing respondents' perceptions about the values education. The teachers were asked whether there is a need values education, what values should be taught (e.g. aims and content of values education curricula), which instructional methods should be used, and how the success of students measured. The responses of participant were analyzed for concentration, depth, and specificity. The perspectives of teachers were categorized according to their differences and commonalities.

There are some ethical considerations in this study: In order to ensure the privacy of participants the names of the participants were not included in the study. Participants' genders (e.g., female as F, male as M), ages, and branches were given in parentheses. Obscure, or doubtful parts of answers were asked again to the respondents and the member-check was provided. It is also said that participating in the interviews is based on volunteerism. Namely, it is explained to the participants that the participants can leave the interview without any compensation.

## 4. Findings

Findings of this study are classified according to research questions. The participants' views were explained under the headings of (1) the need for values education, (2) the organization values education, (3) the approaches and strategies in values education, and (4) suggested assessment methods in values education.

### 4.1. The need for values education

According to the participants, the values are directly affected by social changes and technological developments. Loss of some values leads to social disintegration. Therefore there is a need for education of values in order to keep society together. As said by participant teachers, the loss of some values leads to serious problems in the school and therefore in the society. The following quotes explains this view:

*I think there is a deterioration in our society. Therefore, education of values is absolutely necessary. However, when determining the content, there should be not only religious values but also moral, and universal values should be included. (F, 31, Science teacher)*

*It's not just our country's problem. There is corruption all over the world, violence is increasing. Students are now ruthless and individualized. The corruption that starts in the family is spreading to the individuals in the whole society. (M, 35, Physical education teacher).*

*'Amin Maalouf says that nowadays people treat as if they do not need morality because they have a religion. It's the same situation in our country. Politicians and some educators aim to raise a religious generation. They increased the number of religious lessons, but ironically the immorality, and violence in the society has increased. It would be better to teach the values before religious education. We should teach to live together in peace and concord.'* (F, 46, Philosophy teacher).

### 4.2. The organization of values education

Participants were asked which values worth to teach in the schools, what is the aim of values education, and who should be responsible for values education?

Participants have associated the objectives of values education with affective skill development. Thus, when the teachers were asked, what values should be taught to, many of them suggested that



caring about other people, honesty, responsibility, and sensitivity are the most significant topics in values education. Participants noted that cognitive learning outcomes are linked to the use of emotional and psychomotor dimensions. For this reason, values education should be aimed at producing new values within the existing values of the individual and making them part of the individual's character. The teachers also indicated that if merely academic accomplishments are appreciated and moral values are ignored; thus, self-indulgence, selfishness, and freewheeling are inclined to increase. For this reason, affective skills as well as cognitive skills should be included in the curriculum.

*Parents aim to get the best grade of the children in the 'exam hell' in our country. They are not interested in the feelings, thoughts, attitudes and values of their children. The child whose grades are high is perceived as the most successful child. (M, 47, Physics teacher).*

*I have difficulties of understanding how the parents educate their child. I have doubt that they know how to raise a child. The guys (students) who compete with each other and hide information from each other... They are not friendly, and supportive to each other. A disrespectful, thoughtless, selfish generation... All they want is pass the exam. Exam scores have priority over everything. (F, 42, science teacher).*

Teachers' opinions differ on the issue that who should be responsible for teaching values. As regards responses on whether the value education is the duty of the school or families, it was seen that teachers have different views. Some of the teachers think that it is pointless to try to teach values. According to them, families and the environment are very effective in value teaching. Participants indicate that values education starts at an early age and the base values were given by the families. Thus, when students come to school, they already have some certain values. It is impossible to change the values of the family. For this reason, the task of teachers is to teach the subject of their lessons well, not to teach values. The following excerpts are noteworthy examples of clarifying this interpretation:

*You could not teach anything to a high school student. High school students internalized what they learned from their parents, and from the community they live in when they came to school. It is easy to teach something new to early childhood or primary education students. But to change the attitudes, and behaviors of high school student is difficult. (M, 35, Physical education teacher).*

*We, the teachers, are trying to be role models in school, but the attitudes and values of the parents influence the students. (M, 35, Physical education teacher).*

*Nowadays, families cannot see the mistakes of their child. Everyone's child is very special, very perfect, and unique. In this way, children are not aware of their mistakes. They wouldn't take responsibility for the mistake if they are not aware of them. How could values be taught in this case? I think parents should be educated first about child education and moral development. (M, 34, Chemistry teacher).*

On the other hand, some teachers think that teachers have an important and inevitable role in value education. There are teachers who advocate that value education should start at early childhood education. They asserted that behaviors of the adults reflect the childhood education. That is, when individuals become adults, they will behave the way they were taught to act as a child. Participants maintained that schools and teachers are the most crucial part of teaching values. For this reason, all stakeholders at schools are important to value education and take accountability for this issue. The views of a male history teacher are as follows:

*Teachers should be good models with their behaviors. The environment created in the classroom, communication patterns with the students, and effective use of class time can be seen as a part of value education. (M, 40, History).*

#### **4.3. The approaches and strategies in values education**

The finding study revealed that some teachers suggest that teaching values does not require specific teaching methods. On the other hand, some participants stated that the teaching methods to be used

## Measuring the Perceptions of High School Teachers on Values Education

in the teaching of values should encourage active student participation. The following quote illustrates this view:

*In the education of values, the student must be able to think about real problems. Only memorizing virtuous acts should be prevented. students should internalize virtuous behaviors and make them part of their lives. Case studies should be used, and real news should be discussed in the classroom. (F, 33, social studies teacher).*

Some participants pointed out that there is no need for a separate training program for values education. They also expressed that the values intended to be acquired by the students should be integrated into the other courses.

*For example, in the course of Turkish language and literature, student can write an essay on some values. Similarly, in history classes, events in the past can be discussed. I think the values can be put into all the courses. It is unnecessary to add an extra course to the curriculum. (F, 42, science teacher).*

Participant teachers have stated that value education must be linked to real life. In this context, they stated that they could use case studies, real life stories, television programs, newspapers, and virtual media tools as instructional materials during values education. Participants also stated that during the teaching of values, role playing, discussion, story completion can be used.

The findings also revealed that the use of instructional materials in values education has several benefits such as they increase the effectiveness of the teacher, clarify the concept, encourage the extraction, motivate student learning, give all the students the opportunity to share the experiences required for the new learning and to make the learning more permanent.

### 4.4. Suggested assessment methods in values education

It was recognized that participants were unable to agree on how to evaluate success in value education. Some of the participants argue that traditional assessment methods are adequate, while others suggest authentic assessment methods. Participants advocating traditional assessment indicate that written exams can be used in the assessing values education. On the other hand, participants advocating alternative evaluation, noted that the assessment of affective dimensions is quite complex, and therefore the best method to assess values is to use methods such as observation, exhibition, presentation, and demonstration. Some teachers pointed out that evaluation should not be based on grading in value education. The following quotations exemplifies this opinion:

*It is very difficult to measure affective domain gains. I mean, we cannot understand whether the child is honest, ethical, right and wrong by using written exams. The student writes an ideal answer to pass the exam and may hide his / her true attitudes and values. (M, 33, Visual arts teacher).*

*“... I'm not sure how to measure the values. I think it's best to make observations. It is even better if the students do not get scores from values education lesson. However, then the students would see the values education course as unnecessarily...”*

*Discussions can be made on the events in school when teaching values...debate about the topics in social media can be done. In other words, if you choose real life examples to motivate your students, more effective lessons will be made. The student participates actively in classroom activities (F, 33 years old, social studies teacher)*

*Values education should not be limited to school walls. Values can be learned in cinema, on the bus, on holiday by informal ways. I think adults should be good role models. (F, 40 years old, social studies teacher).*

## 5. Discussion

Values are the priorities given to specific beliefs, experiences and items in order for individuals and society to choose how they will live and appreciate (Hill, 2004). Today's school societies have to deal

with numerous factors that impact students' moral values, thereby, diminishing the effects of these factors educators and families should take some measures. According to the results of this study, among these factors, media, globalization and high stake exams in education systems are most commonly mentioned for causing corrosion of moral values.

Findings from the study reveal that value education should begin at an early age. This finding is consistent with Meslier's views. Consistent with Meslier (2014), human mind looks like a soft wax, especially in childhood, it is ready to accept all changes which desired to change it. Therefore, education can give all thoughts, beliefs and views to the children at their early ages.

It seems that schools do not develop a separate curriculum for values education, and values education is integrated into the curricula. It is suggested that education of values should be part of school life. The physical and emotional atmosphere in the school should be arranged in such a way as to emphasize the planned values. That is, all activities, spaces, tools-materials, and relationships must be designed around values. In the values education, teachers can use printed materials (e.g., textbooks, supplementary books, workbooks, reproduced drawings, worksheets prepared by the teacher, reference books, brochures, journal articles). Information communication technologies can also be used, for example podcasts, virtual media (twitter, facebook, flickr, tumblr, instangram). They can also utilize audio-visual materials such as music player, tape recorder, phonograph, recording devices.

Findings of the research disclosed that values education not only related to the content of religious education, thus, all courses in the curricula should include values. Having religion does not mean forfeiting the moral values. Meslier (2014) explained the relation between religion and values education as follows: In order to realize and choose the real moral principles, people do not need theology, or divine inspirations, but common sense. To teach people they should be fair, benevolent, understanding, good-natured, and get along well with other people, not because the gods want it but to win people's love. People should be taught to avoid immoral behaviors, not because they will be punished in the hereafter, but because they will be responsible the consequences of their misbehaviors in this world. The moral values can change through demonstrating good examples.

Values education should not be planned as a course passed by taking exam scores. Care should be taken to create teaching environments that will enable individuals to internalize basic values. Teaching activities that require active participation of students should be used to enable individuals to recognize and appreciate the values.

The findings of the research showed that teachers do not have enough knowledge on preparing instructional materials and assessment instruments for values education. To ensure fulfillment of the aims of values education, one would, first and foremost, recommend that, teachers can provide in-service training on the use and preparation of various instructional materials.

## 6. Conclusion

In the light of the findings of this research, it can be suggested that teacher education institutes should cover the instructional approaches to teaching values in the classroom. There is a need an interdisciplinary study to investigate the factors that impact people's values deeply and certain kind of instructional approaches to support students' moral development. The data of this study is limited only to the qualitative data obtained from public high schools in Ankara. Following researchers are recommended to conduct a more detailed research in different regions and with different research methods.

It can be concluded that the teachers' views reflected to the aims, objectives and content of school curricula. The results of this study are expected to be enlightening for educators and other constituents of community.

## 5. References

- Aspin, D. N., & Chapman, J. D. (2007). *Values Education and Lifelong Learning: Principles, Policies, Programmes*. Springer Science & Business Media.
- Department of Education, Science and Training (DEST). (2005). *Report on National Values Education Forum*. Australia.
- Durkheim, E. (1961). *Moral education*. New York: Dover Publications.
- Halstead, J. M. (1996). *Values and values education in schools*. In J. M. Halstead & M. J. Taylor (Eds.), *Values in education and education in values* (pp. 3–14). London: The Falmer Press.
- Hill, B. (2004). *Values education in schools: Issues and challenges. Paper presented at the National Values Education Forum*.
- Jones, T. M. (2009). Framing the framework: Discourses in Australia's national values education policy. *Educational Research for Policy and Practice*, 8, 35–57.
- Kumta, J. (2013). *Approaches to Value Education*. Retrieved from <http://www.teachersofindia.org/en/article/approaches-value-education>
- Leming, J. (1997). *Research and practice in character education: A historical Perspective*. In A. Molnar (Ed.), *The Construction of Children's Character*. Chicago, IL: The National Society for the Study of Education; distributed by The University of Chicago Press.
- Manichander, T. (2016). *Value Education*. Laxmi Book Publication, Solapur.
- Meslier, J. (2014). *Good Sense: The Illusion of Godlessness*. (Translation: Cevdet, A.) Kaynak Yayinlari. Istanbul.
- Powney, J., Cullen, M.-A., Schlapp, U., Johnstone, M., & Munn, P. (1995). *Understanding Values Education in the Primary School*. York: Reports Express.
- Solomon, D., Watson, M., Battistich, V. A. (2001). Teaching and schooling effects on moral/prosocial development. In V. Richardson (Ed.), *Handbook of research on teaching* (4th ed., pp. 566–603). Washington, D C: American Educational Research Association.
- Taylor, M. (1994). *Overview of Values Education in 26 European Countries*. In M. Taylor (Ed.), *Values education in Europe: A comparative overview of a survey of 26 countries in 1993* (pp.1–66). Dundee: Scottish Consultative Council on the Curriculum.
- Thornberg, R. & Oguz, E. (2013). Teachers' views on values education: A qualitative study in Sweden and Turkey. *International Journal of Educational Research*, 59, 49–56.



# Primary Education Practices of National Education Ministers (1999-2011)

Mehmet Cetin, Adil Adnan Ozturk, Sukran Demirkaya

## 1. Introduction

Education with its most known definition, is a process that cause the people's own behaviour and intended, positive results (Erturk; 1994). Despite the different opinions, Educators perceive the Education is a changing process. So As a result of these process, absolute changings expected by the educators (Tekin; 1979). In another definition education is a all social process which cause effective role to gain people's society standarts, beliefs and lifestyle (Karsli, 2008: 9). Teach one children one adolescents, bring-up them with helping them to develop their personality, oriented their development process, educating one person or one group is a developments to some skills, informations and culturel iformation on them. Educating one community will provide special informations that they will have their future functions (Big Larousse Dictionary and Encynlopedia).

The mankind born with the learning potancial. The human obtain the necessary life information to maintain their life after they start living. The Humankind increase their accumulaton wich they inherited from their family and their enviroment and maintain it with their own experience. The difference between the people who lived a centrury ago and today is because of this stuation because the attitude, perception, thinking style, lifestyle were different because of these things(Taskesen, 2006: 6). When the communities started to now generations will also became more increase. When the communities and their structures and resources became more complex, corparate or systematic education needings increased (Dewey; 2004). As a brief education is a very big term wich contain tecahing (Akyuz, 2006).

If we look to Turkish Education history, We will see that thanks to big efforts of some minister of education some Administrators, some teachers, The Turkish Education system show some, improvement even if they are not expected level. Changes to administrations causes to pauses pozitive efforts even sometimes stop them and these unstability give great damage to education system. Especially fast efforts with full of political thoughts and discourses opening the ways of failures and big preblems.

In this context the governments which were on the power between 1999-2011, beside social and economic areas, they also made some changes and innovations on the education system. In this Research, it has been examined ministry of Education who had been worked between 1999-2011 and their performances.

## 2. Methodology

Method is away to access certain aim or to produce solitions to solve certain problem. Method is all the mental process that use to access real result (Keles; 1982). In order to reach intended result, the method must chosen the most suitable one and perfectly aplied (Kaptan, 1998: 45-46). In the research, scanning method used, document analysis were made. The results were resolved as a word document and descriptive analysis done.

## 3. Universe Of Research

The universe of the research create the 5 minister of education who take part in between 1 January 1999 and 7 July 2011 in Turkish Republic Governments.

**Table: Minister Of Education Between 1999-2011**

<b>Minister of Education</b>	<b>Date of start-finish</b>	<b>Gorev yaptigi hukumet</b>
Metin BOSTANCIOGLU	11.1.1999- 09.07.2002	5th Bulent Ecevit government (56th government)
Necdet TEKIN	10.07.2002-19.11.2002	5th Bulent Ecevit government (57th government)
Erkan MUMCU	19.11.2002-17.03.2003	Abdullah Gul government (58th government)
Huseyin CELIK	17.03.2003-03.05.2009	R.Tayyip Erdogan government (59th and 60th government)
Nimet CUBUKCU	03.05.2009-07.07.2011	R. Tayyip Erdogan (60th government)

#### 4. Collecting Informations and Evaluaiting

In this research we use scanning modele and we also use document analysis and descriptive analysis. It has been examined the period of minister of educations what kind of innovations brought-up the education system and what kind of works they did. The result have been taken and evaluated in this research. After then their point of views to education system were evaluated. Also we keep in front of the eye their statements to give the press. The speeches they did on the council, broadcastic messages and the speeches they did at the time of education year. As weel as these things their parties general views about education system and their party programmes were also evaluated during the preparing process of this research. As a briefly during the period of solving problem of we applied some documents and They are:

- 1) The government programmes which were set-up during 1999-2011
- 2) Development Plans
- 3) The Speeches about education wich wered one Education ministers and deputies the time (1999-2011) on the parliement.
- 4) The speeches wich were to press about education by minister and press conferance that the given by minister.
- 5) The formal statistic were about education.
- 6) National education notification magazine
- 7) Books, essays, thesis about education.

#### 5. Findings

##### 5.1. Minister Of Education and Their Works

In this part we will try to explain the ministers who worked between 1999-2011 as a ministers of education and try to analysis their performances

##### 5.2. The Performance Of Metin Bostancioglu

At the time of Bostancioglu for the student who lived in a place there were no scholl the transporting training system spread and this cause the spread of primary school system. Between 1999-2000 619.324 student moved to 5321 central school as a result of investments, the number of boarding-district scholl number increase the 220 and pensioned primary school number increase 161 and between this there was 9 girl district scholl.

At the time of him snap capture project have been prepared and applied. Via this project between 2000-2001 education year They aim to access %100 schooling rate, step by step finishing the unified classes, step by step decrease class sizes around 30 and starting single teaching and They aim to increase the quality of education and in order to access these aims, they determine principles and politics (TBMMD, B:57 O:1, 2000:146).

Now we will look the statistic at the time of Bostancioglu

**Table 2. Primary School, New Record, Number of Student, Number Of Teacher, Graduated**

Years	Number of school	New record	Number of student	Number of teacher	Graduate
1998-1999	45.102	1.229.706	9.609.050	317.790	705.140
1999-2000	33.317	1.250.771	10.028.979	325.140	824.789
2000-2001	36.072	1.316.194	10.480.721	345.015	1.071.189
2001-2002	35.052	1.293.697	10.477.616	372.687	1.071.606

References: MEB, 2010: 89.

According to the table when Bostancıoğlu started his work the number of schools was 45.102, which decreased to 35.052. This decrease is mostly due to the transportation system or students continuing their education at boarding schools. Also, the Marmara earthquake caused the decrease because so many schools were collapsed or damaged.

Also at the time of Bostancıoğlu, the number of students increased from 9.609.050 to 10.477.616, which is a 9.03% increase in total. The number of teachers increased from 317.790 to 372.687, which is a 17% increase in total. If we look at the schooling rates between 1998/99, the rate is 89.6%, between 1999-2000 it is 93.54%, between 2000-2001 it is 95.28%, and between 2001-2002 it can be seen as 92.40%.

### 5.3. Minister Of Necdet Tekin and His Works

Between 10 July 2002 and 19 November 2002, namely for a four-month period, he held this job. His perspective on education was closely related to the programs of the left parties. Throughout the ministry, he worked in line with national principles and targets. He continued the performances that started before his time. He did not make a contribution to formal and informal education.

#### 5.3.1. Primary School Of Performance

At the time of Tekin, digital data is as follows: In the 2001-2002 education year, there were 9,975 national primary schools in cities, 25,149 national primary schools in villages, and a total of 34,424 national primary schools. There were also 575 private primary schools in cities and 53 private primary schools in villages, for a total of 628 private primary schools. If we look at the merged classes in the 2001-2002 education year, there were 18,517 schools, 914,074 students, and 35,669 teachers. If we look at the transportation data, there were 5,373 schools moved, 27,665 schools transported, and the number of transported students was 636,508. At the same time, in open primary education, there were 219,696 students and 143 teachers. In boarding primary schools, there were 275 schools, 5,556 teachers, and 139,971 students (MEB, 2010: 89-96).

### 5.4. Minister Of Erkan Mumcu and His Works

He also held the ministry of education for only four months, so he was not able to achieve most of his goals. The digital data was like this in his time. At the time of Erkan Mumcu, the compulsory uninterrupted 8-year education system was applied, but it did not have an important effect on primary education. It was just a continuation of the past. At the time of Erkan Mumcu in the 2002-2003 education year, there were a total of 35,133 schools. If we separate them by location, there were 25,103 in villages, 9,442 in cities, and 608 private primary schools. During this period, there were 10,331,303 students and 373,303 teachers in the part-time education system (MEB, 2010: 90).

In the 2002-2003 education year, the schooling rate was 90.98%, and they also removed the monotype school clothes and left the decision to the administrations.

### 5.5. Minister Of Huseyin Celik and His Works

The biggest changes that happened at the time of Huseyin Celik were the changes in the primary school curriculum. In the 2004-2005 education year, a school in a city of 120 was chosen as a pilot school and the constructivist approach with a formatted curriculum was applied. In the 2005-2006 education year, it was applied in all schools. After that, all teachers were taken into service training courses.



At the time of Huseyin Celik, there were happen alot of development both as a quality and as a quantity. Such as 10.250.000 scholl books distributing by goverment without money in 2003-2004 education year and this books costs was 157 trillion in 2004-2005 education year in Turkey and in other 11 country totally 83.119.000 books distrubited by goverment without Money (TBMMTD, B:73, O:2,2005: 253).

At the time of Celik the number of the hostel were increased for the students who live in rural area and needed boarding schools to get education (TBMMTD, B:10, O:1, 2004: 77). Also let's girl to school campaign was started this campaing was maintained with unicef in the first six month of the 2003, 40.000 girl were reclaimed to school who were missing by their schools with a different problems (TBMMTD, B:16, O:4, 2004:145).

This number was over the 70.000 in 2004 as a tecnology at the time of Huseyin Celik 84.000 new computer sent to All over the Turkey and for 43.000 school eneternet service provided (TBMMTD, B:40 O:2, 2004:589). 1400 school reopened for the education for the school buildings 41 project was prepared and they were displayed on the ministry (TBMMTD, B:58, O:2, 2005:280). At the time of Celik LGS system was changed and brought to OKS system with OKS system applications were done online (TBMMTD, B:62, O:2, 2005:280).

It was the first time when students enter pisa exams which was pegulated by OECD also happen in Celik time. If we look the PISA results in 2003-2006-2009 and compare with other OECD countries, in reading skills, Turkey in order 33th, 28 th and 32th in matematic skills turkey 56 th, in science skill 64 th, Turkey as a level in a very low situation and this is a result of shortcomings of education system.

Also at the time of Huseyin Celik Conditional cash transfer (CCT) namely as the people know child's money given for the people who has no regular income who hasn't connected any social security institution and because of these things they couldn't benefited these things. In conditional cash transfer seperated three type and these are education, health and pregnancy. Between 0-6 ages they gave health aid for the child. Between 6-17 ages they gave education aid for students and for the pregnants for pregnancy aid. When we look the 2005 the number of people who was taking these aids as student 1.226.331 and as a home 697.904 (TBMMTD, B:40, O:4, 2005:790).

On the other hand in 2006-2007 in order to increase students motivation to decrease their stress and to provide more enjoyable time for students who started first classes taken into class one week earlier. Also Heart-bridge project started, which is aiming to young people to provide them to see different parts of our country and via this they will be aware of the different cultures and people and increase the love and respect, friend ship sharing, help ingunity and togetherness and built-up permanent heart-bridges in totally 17.520 student took part in this organization (TBMMTD, B:33, O:2, 2008:985).

**Table:3 Total Number of Students and Schooling Rates In Primary Schools (2003-2009)**

Years	Total student	Schooling rate ( % )
2003-2004	10.479.538	90.21
2004-2005	10.565.389	89.66
2005-2006	10.673.935	89.77
2006-2007	10.846.930	90.13
2007-2008	10.870.570	97.37
2008-2009	10.709.920	96.49

Reference: MEB, 2010: 249.

## 5.6. Nimet Cubukcu Performance

### 5.6.1. Primary School Performance

At the time of Nimet Cubukcu in Turkey there were 11.051 national school in cities, in the villages there were 21.380 and totally 32.431 national primary school as a private school in the there were 789 school in the cities and 90 school in the villages an as a totally there were 879 private primary school. In merged

classes there were 11.348 school, 349.202 student and 12.424 teacher. If we look the statistic of transporting the number of carried schools were 5759, the number of transported schools were 23.072 and the number of transported students were 667.641 in boarding primary schools there were 574 school, 13.571 teacher and 265.285 student. As a blind primary school there were 15 school, 392 teacher and 1325 student, as a deaf people's primary school there were 49 school, 1096 teacher and 4598 student, Also as an orthopedic disability people's primary school there were 35 school, 79 teacher and 485 student (MEB, 2010: 89-95).

Outside the rural areas and in places where the geographic situation is not very difficult converted into boarding district schools and students who are under 12 and under 5th classes taken in to scope of transported student and carried from their home to school. With greater classroom instruction programme the children who were (the range between 10-14) stay-away- the school because at different causes, returned to school (TBMMD, B:111, O:4, 2010:849).

## 6. Evaluation And Comments

In the period of that we make an research (11.01.1999-07.07.2011) 5 government was established. In this period the governments often changed in a parallel so much minister of education changed. During the 12 year 5 month 26 day, 5 minister changed.

### 6.1. Primary School

It is intended to send to children the nearest school where he/she lives-in. But most of time because of our countries geographical and population distribution problems, this aim is not totally true. In some villages because of low population, the teachers employment can be difficult. As a result of it the student who live there taken in to scope of transporting training education or sending boarding schools so that they can benefited from primary school education.

In last ten years time the studies of accelerating of the schooling rates near the %100 but it couldn't reach totally. As of 2009-2010 this rates detected as %98.17 in primary schools. With the help of lets girls to school project increased the numbers of the girls in schooling rates. Inequalities between regions with regard to education still going-on. The number of students who are getting dual education and studying in unified classes still very high. These are causing the decrease of education quality and productivity. The average of students who are studying primary school is very high in Turkey compare with OECD countries. As of 2008-2009 education year the average number of classes is 28 in Turkey but in OECD countries this number fall to 21,4 beside this, the real problem.

In some regions the average number of students under 20 because of different problems such as social and economic problems, immigration but in a big cities the average is so high. Certainly it can be very big mistake to connect the problem only with MEB, the real problem is original. From different level of developments of regions security problems and population increases. With these things as a result of fast conversions and as the ministry doesn't long term plans to population growth rates (because in some regions fastly increase and in others fastly decrease) or in complete plans so they cause whether to intensive or the schools closed because of inadequate number for example in our country there are nearly 22.000 primary school unable to train because of insufficient number of student. These are all cause of waste of country resources.

### 6.2. New Curriculum

There was some problems to application of new curriculum which was brought in the period of Huseyin Celik. If we evaluate this curriculum. The biggest problem that encountered was the places where the curriculum was applied not enough suitable and teachers were not enough ready to it and these are increase the problems. According to constructivist approach, the edited curriculum needed to interested personally to every student and also according to multiple intelligence need to use different educational methods to every students learning field to help them to learn. These are intended situations but as a theoretic area can be ideal but in practical seen different problems. Despite the increase the numbers of school and classes in our country still average number of classes so high in a big cities that blocking the

application of new curriculum. Also in unified classes goes-on having problem to application of contrastivism.

After making pilot practice in 2005-2006 education year new curriculum applied in all over the country. The biggest mistake was without having enough evaluating and without seeing shortcoming and results. They started to new curriculum as a result of these things, teachers, administrators and inspectors had a big problems. Also as physical equipment, technical competence and capacity problems seen.

## 7. Discussion and Result

Since the modern Turkey was founded by the leadership of Ataturk in 1923 then 2011 which is the date of our research topic, the biggest problematic, complex and unstable topic can be seen as a education. In every stop of education there is problem to solve. During the time between 11.01.1999 and 07.07.2011 five government established. Two of these five belongs to Ecevit coalition governments (56th and 57 th) the others AKP governments (58 th, 59 th, 60 th ) in these three government, there was three different ministry of education.

In the period that we examined the first minister of education was Metin Bostancioglu He started his task of after Hikmet Ulugbay. At the time of Hikmet Ulugbay without exactly created the compulsory eight years Education law was accepted. From the beginning of day The Metin Bostancioglu try to overcome the problems which arose from compulsory education. After Metin Bostancioglu resigned from ministry of education, Prof.Dr Necdet Tekin start to relative between 10.07.2002 and 19.11.2002 he carry-on this task. On his time there was not any important performance that happen in education system. Current state went-on.

After the early election that happen in 2002 the AKP government elected as a ruling party and Erkan mumcu was appointed as a ministry of education in 58 th government. As Erkan Mumcu carried this task only for a four month times he couldnt do his targets. In the period that we examined the longest time work on this task was sustain by Doc. Dr.Huseyin Celik. He went-on this task 59 th, 60th government and 60 th government period. During his period He did new curriculum changes and educational contribution camings and do many innovations.

After cabinet changed Nimet Cubukcu was brought as a new education minister. She carried out this task between 03.05.2009 and 07.07.2011 in this time it was stick to government programme and targets of national education and the educational studies went-on in this context in her time the most draw attention performance was SBS exam which applied in 6th, 7th, 8th classes was step by step removed and nev SBS exam bring-out whic is only applied in 8 th classes.

The performances which was happen during these education of ministry will be evalvated and will be seen the affect on the primary schools system effect on the community and missing directions also detected and new suggestions will offer. As you can se there have never seen continuity incoming government and ministers continuously in efforts to make changes and innovations and this is generally doing as a ignorence of previos and doing back to square one. For example entry system of from primary school to middle school is changing almost every year and this cause the shaking confidence of both student and parents perspective to education.

The changes which happen in what ever topic doesn't enough calculated. Without waiting enough time to see trial process of result of changing in system they start appication process and this problem also cause the defined targets and planned education can not be applied in classes and school levels. In the work done it is mentioned about the problems of quality in our schools, the problem in our system is not because of the failure off apply to our student that they learn, as they couldn't gain the main informations and skills. The main reason of this thing is that they pass the upper classes without gain standart of main knowledge at skills. It is very important that in order to in crease quality of education and also in order to increase productivity all student must pass upperclass after they obtain standart they need.

The biggest problem that have been seen in Turkish education system doesn't have clear aims and education politic is very uncertain. The performance which have been done. For short time and in order

to save the day. Also deprived of certain strategies and it doesn't done anything to increase the quality of education for along time period. In the work have done the certain missing points detected and solution proposals as follows

- 1) Education system and policy should be seen as a whole. It must calculated that when a part of system change how it will affect general and planning shouldn't do at over one part, should consider a whole. In the education without consider others of it should a void doing changes. Changes should be done step by step so that if can be stop be victims of students and fiels and increase the trust of education
- 2) In national education policy should consider the reconciliation with others and universal aims and princibles must be in their arrangements.
- 3) It must give permission to use different method and tecnique in education places. For the purpose of the course, for the level of students if they need it must be stretch the student-centered methods and apply traditional methods in some cases.
- 4) Course load periods should be determinate according to students developmental features. It shold be know that to much lesson hours is not affective and efficient especially in the first years of education the lesson hours that she students responsible for must be decrease.
- 5) It must be finalized both dual education and unified class applications.
- 6) It must be finalized transport training system in primary schools
- 7) The class sizes must be decreases in primary schools.
- 8) In order to increase the productivity and quality in education system there must be important changes in pass-grade system. Students must pass the upper classes After they obtain the standarts what they have to get. The student that doesnt gain the standarts should take reinforcement courses and later they should pass.
- 9) The process-oriented evaluation system that located between new primary school curriculum should be applied affectively. The harmony between aims of education, teaching on the subject and assesment and evaluation should increase
- 10) In order to increase the quality of education it must make wide evaluation to intended students, teachers and families it must be done continous operations to see that how much the aims took place to see missing points and to see the quality of materials to prepared education system.
- 11) In order to catch development countries education levels in term of class and school size we sholud do improvements also schools should equipped with tecnology and it must be provided to broadcasting to national wide

## 8. References

- AKYUZ, Yahya (2006), Turkish Education History M.O 1000- M.S 2006 Pegem Publishing 10th Printing, Ankara
- Big Larousse Dictionary and Encynlopedia (1986) Gelisim Publishing, Volume: 6.
- DEWEY, John (2004), Democracy and Education, Yeryuzu Publishing, Ankara.
- ERTURK, Selahattin (1994), Curriculum Development in Education, meteksan, Ankara.
- KAPTAN, Saim (1998), Scientific Research and Tecnique of Statistic, Volume:11 Tek Isik Ofset, Ankara.
- KARSLI, Mehmet Durdu (2010), Introduction to Educational Science, Pegem Publishing, Volume:3 Ankara.
- KELES, Rusen (1982), Research Methods (Coursenotes TITA), Trabzon.
- Main Britanica (1992), Volume: 6.
- National Assembly Parliamentary Minutes Magazine (2000) B.57,O:1 page 146-147
- National Assembly Parliamentary Minutes Magazine (2004) B;10,O:1 page: 77
- National Assembly Parliamentary Minutes Magazine (2005) B:40 O:4 page 786
- National Assembly Parliamentary Minutes Magazine (2005) B:40 O:4 page 790
- National Assembly Parliamentary Minutes Magazine (2005) B:58,O:2 page 280
- National Assembly Parliamentary Minutes Magazine (2005) B: 62, O:2 Page 280
- National Assembly Parliamentary Minutes Magazine (2008) B:33,O:2 Page 985
- National Assembly Parliamentary Minutes Magazine (2010), B:11,O:4 page 849

National Ministry of Education (2010), Improvements on the System of Turkish Education System on the Period of Republic (1920-2010), National Education Publishing, Ankara.

Taskesen, U. 2006 "Hasan Ali Yucel Education Philosophy on Contribution of Education", Graduate Thesis, Selcuk University, Konya.

Tekin, H. Assesment in Education Mars Matbaa, Ankara, 1979.

# The Opinions Of School Administrators On The Teacher Performance Evaluation

Munevver Olcum Cetin, Ismail Erol, Pelin Karaduman

## 1. Introduction

Throughout the history, humans have come together for common goals and communities called organizations has come out. To achieve the goals of these organizations, each person in the organizations has some roles and responsibilities. According to some researchers (Basaran, 1991 and Aydin, 2014) within a limited time, idea, product, and any other kinds of results which are the people's acts of his roles and responsibilities in order to achieve the goals of organizations is the term, performance. It means performance is the behaviors and the products that are done to fulfill business requirements in a time zone.

As all the humans are not same, the people's interests and behaviors towards the work will not be the same. For this reason, the differences of employees in an organization should be monitored and evaluated in order to determine the differences in an objective way and accomplish the goals of the organization. Sabuncuoglu (2012:184) states that in order to get high efficiency in an organization, the abilities of the employees should be monitored and evaluated in accordance with the success which is improved. Aydin (2013:154) states performance evaluation as "make sense of relative or concrete performance measures in terms of performance standards or effectiveness levels". Performance evaluation is observing all activities, deficiencies, sufficiency, pluses, and inabilities of all employees whatever their work is. The question why this observation is a necessity reveals the importance and need of performance evaluation. This need comes from the nature of human. Human is a social being. They are always in touch with their environment. Humans are in need of being informed in their relations between others, confirmed, even encouraged and appreciated. These are all natural needs for humans (EARGED, 2006:7).

Performance evaluation helps employees and administrators in organizations. According to Helvaci (2002:157) some good sides of performance evaluation are like these: It helps employee to understand what is wanted from him/her; it helps to understand what is needed to achieve the aim; it helps to define his/her current situation, improvement and in what area he/she needs education in order to improve himself/herself; it helps to be aware of what the expectations in terms of duties are clearly; it helps administrators to give more objective feedbacks and guide more affectively; it helps to plan personal improvement and educational needs in a more effective way; it helps administrators to have more efficient relations with employees.

In order to determine the levels of performance of employees, there are many kinds of methods. These methods can change in accordance with the aim of performance evaluation. Some of these are labeled classical now and some are the modern methods that have been developed to have more objective evaluation and solve the problems that are came across during the evaluation process. Each of these methods has different advantages and disadvantages. Organizations should have performance evaluation by choosing the appropriate method according to their aims and employee's quality and sometimes make performance evaluation with their own approach using some of the methods (EARGED, 2006:7). Schools are a kind of organizations, so when we think school environment, performance evaluation of teachers has also beneficial effects on the organizations. For Stronge (2006), the main aim of education is teaching and learning and if there is good teaching, then the outcome will be good learning. To fulfill the aim of education, evaluation is needed. Teacher evaluation is firstly about recording the nature of the teacher's performance and then helping the teacher to improve their performance. It is also about helping the teacher to be accountable for his work. According to Peterson & Peterson (2005:78) to have a fine teacher evaluation, there should be a good contact between teachers, administrators and people related with school and good teacher evaluation includes:

Improved evaluation should be done by administrators, to have multiple data sources, teacher evaluation procedures and forms must be improved, there should be a student achievement system, there should be programs for staff improvement on evaluation theory and practice, there should be technical help and recommendation for teacher to involve in the evaluation and for their self evaluation, there should be mentoring programs, there should be substitute teacher support for evaluation, there should be always ongoing searches, improvements and verification of teacher evaluation system and practice, there should be public relations for teacher evaluation data.

Traditional performance evaluation system is one-sided and just the managers evaluate the employees. In this system, opinions, feelings and values of the evaluators are so affective that suspicions for objectivism and reliability come out. For this reason, openness, participation, objectivism become important parts of evaluation system. In order to decrease the mistakes because of the evaluators, 360 performance evaluation system, which includes more than one person to the evaluation, has come up recently. Ministry of National Education has wanted to apply this method (Kocak, 2006:786). According to Altundepede (1999:84) teacher performance evaluation is not an activity which is done by just expert, inspectors or school administrators, for teacher evaluation, students, parents and teachers themselves should also evaluate. In Turkey, In 2006, Ministry of National Education EARGED published "Performance Evaluation Method Model" and in primary schools, pilot study was done.

Teacher evaluation has great importance all over the world and in recent time, teacher evaluation in Turkey was done by inspectors' inspection reports and also because teachers are also a civil servant, the teacher evaluation was done by registration reports. In primary school, teacher performance evaluation was done by primary inspectors; in secondary and high schools, it was done by the inspectors of ministry of national education. However, with the official journal published on April 17, 2015, teacher performance evaluation was transferred to school administrators. Statement 54 is about teacher evaluation. According to this statement "the evaluation of each teacher who works at any kinds of schools and whose teacher candidate has finished is done by the school administrators of the same school at the end of academic year in order to evaluate success, productivity and efforts."

## **2.Method/ Data Collection and Analysis**

The aim of the study is to find out the opinions of public school administrators, who work in Suleymanpasa, Tekirdag during 2015- 2016 academic year, on the new teacher performance evaluation. It is a qualitative study. The qualitative studies are conducted by interviews, observations and document analysis, etc. in order to find out events and perceptions totally and really in their natural setting (Yildirim & Simsek,2008). Accordingly, in the study semi-structured interview method, which is useable for qualitative studies, was chosen in order to understand how school administrators understand and interpret the new teacher performance evaluation. This method is useable if more detailed questions on a specific topic is needed or the answers are not enough and again new questions on the same topic are needed to make things clear (Cepni,2007). In the study group, there are 15 public school administrators. 4 of them work at special education schools, 5 work at primary, 3 work at secondary, 3 work at high school in Suleymanpasa, Tekirdag. Semi structured interview form which included 12 open ended questions was prepared by the researchers. All the teachers work at public schools. The questions which were prepared for the aim of the study are as listed below:

1. What kinds of problems have you come across about the process of teachers' planning of education term? What do think about the convenience of the plan that the teachers have planned to the students?
2. While evaluating teachers, what have you come across about the teachers' regulation of education environment? According to you, while doing teacher evaluation, what tasks fall to the teachers for the regulation of education environment?
3. What are your feedbacks for the evaluation of teachers communication skills? What can be done to test their competence?
4. What do think about the competence of the teachers to motivate students while evaluating teachers? What should be taken into consideration during the evaluation?

## The Opinions Of School Administrators On The Teacher Performance Evaluation

5. What should be paid attention while analyzing the teachers' usage of school environment's opportunities? Do think that teachers are using opportunities of school environment?
6. Do think that time management is important on teacher evaluation? Do teachers are using time affectively?
7. On evaluation, to what extent is the teachers effective use of appropriate teaching method and technique important?
8. While evaluating the teachers, what do think about the teachers' evaluation of the education process and giving feedback? Do you think that teachers are doing enough transparent evaluations?
9. While evaluating teachers, to what extent is the accordance and contribution to school's teaching policy important?
10. What should be there to evaluate the teachers display of the appropriate attitude and behaviors of teacher profession?
11. Are the criteria of teacher evaluation enough? According to you, how often should it be done and what do you think about sharing the results of evaluation with teachers?
12. On teacher evaluation, should there be opinions of parents and students? Should this evaluation be a bench mark for career stages?

Before the interviews, participants were informed about the research and the interviews were recorded with recorder. Then, the interviews were written by using computer program. Each interview was lasted approximately 40-80 minutes and then they were written. The data were analyzed by using content analysis. According to Yildirim and Simsek (2008) the data collected qualitatively is analyzed in 4 stages. These are "data coding, theme determining, data and theme organizing, findings describing and commenting." The answers of participants were firstly written on computer and then by reading again and again data coding stage was done. During coding stage, data were evaluated by three people, 2 of them are doctorate students at Education administration and supervision and the other one is professor at the same department. After coding the data, themes under specific categories are determined and sub-themes are done by dividing themes in themselves in accordance with codes. In order to evaluate reliability, the formula offered by Miles and Huberman (1994) was used.  $Reliability = \frac{Agreement}{Agreement + Difference\ of\ Opinion}$ . By conducting the formula, reliability was calculated as 0.93. In this study, in order to support the opinions of participants, direct quotations were given when necessary.

### 3.Findings

14 of the administrators who have participated to the research are male, just one participant is female. 2 of the participants are 20-30 years old, 7 of the participants are 31-40 years old, 5 of them are 41-50 years old, 1 of them is 51-60 years old. 6 of the administrators who have participated in the research were graduated from primary school teaching department, 2 of them are from Turkish language and literature teaching, 2 of them are counseling, 1 is religious culture and moral knowledge teaching, 1 is preschool teaching, 1 is Turkish language teaching, 1 is English language teaching, 1 is special education. When we look at the administration year of the participants; 6 of the participants have been administrators for 0-5 years, 4 of them have been for 6-10 years, 3 of them have been for 11-15 years, 2 of them have been administrators for 15- and above years. The number of teachers at the participant administrators' schools are like this: there are 0-20 teachers at 2 schools, there are 20-50 teachers at 9 schools, there are 50-100 teachers at 4 schools.

The data gotten by the interview form were firstly written by Word Office from voice records. Then, they were read for a few times and then codes were done accordingly. On the Table 1 which is below, the codes were formed by the analyzing the questions. These codes were many times repeated on the interviews done with school administrators and seen as important were listed:



**Table 1: Codes of Data According To Questions**

<b>Questions</b>	<b>Codes</b>
<b>1 st Research Question</b>	Copy-Paste Method (4), Using ready plan (4), Not paying attention to the students (4), Not paying attention to the differences between regions of the country (3), No individuality (2), Not reading the plans (2), The teachers who come to the class without any preparation (2), Laziness (2), Unqualified Inspections (1), Age (1), The number of the students in the class (1), Using Turkish (1).
<b>2nd Research Question</b>	Technology Usage (4), Material Usage(2), Hardworking Teachers (2), Using Different Methods (2), Seating arrangement (2), Absence of security measures (2), Financial incapability (2), Including students to the lesson (1), Need of assistance (1), Necessities of the new century (1), Catching the students' level(1), Planned Teacher (1), Using the school's all setting (1), Technical inadequacy (1), Grouping the students (1).
<b>3rd Research Question</b>	Need of Inservice Training (7), Lack of Interaction with Parents (5), Interaction with Students (4), Interaction with administration (3), Using Turkish well (3), Colleague Relations (3), Being an example (2), Affection (2), Affect of social media (2), Body language (2), Following technology (1), Inadequacy of diction (1), Fear of complaints (1), Inability of self-expression (1), Not being enterprising (1), Lack of self-confidence (1), Appropriateness to the level (1).
<b>4th Research Question</b>	Understanding students (3), Appropriateness to the modern-day (2), Using different methods (2), Differences between education level (2), Having dialogue with students (2), Lack of motivation (1), Giving feedback (1), Taking attention (1), Using technology, Coming ready to the lesson (1), Distractibility (1), Planning (1), Political views (1), Institutional Interaction (1), Experience (1), Guidance of administrators (1), Being focused on success (1).
<b>5th Research Question</b>	Environmental possibilities (6), Teacher want (3), Suitability to the lesson (3), Opportunity training (3), Participation of family (3), Planning tours (1), Age of the teacher (1), Dialogue with school environment (1), Country construction (2), Sponsors (1), Connection with administration (1), View of environment to the students (1).
<b>6th Research Question</b>	Coming to lesson on time (8), Using technology (5), Time management (4), Problem with using time (3), Duties and responsibilities (3), Guidance to the teacher (3), Distribution of the subjects (2), Age (2), Doing all the activities (2), Absenteeism (1), Being a model to the students (1), The time given to have a rest (1), Number of the students in the class (1).
<b>7th Research Question</b>	Suitability to students (7), Suitability to the subject (5), Suitability to the daily life (3), Opportunity training (3), Readiness of the students (3), Making learning easier (2), Being incentive(2), Coming to the lesson ready (1), Overcrowded classes (1).
<b>8th Research Question</b>	Transparency (7), Informing students (6), Being objective (4), Not discriminating (3), Appropriateness to the ethic values (2), Informing the parents (2), Counseling activities (1), New evaluation methods (1), Knowing Students (1), Economical expectations (1).
<b>9th Research Question</b>	Shared decisions (5), Institutional loyalty (3), Benefits of the school (3), Being sharer (3), Cooperation (3), Innovativeness (2), productive

## The Opinions Of School Administrators On The Teacher Performance Evaluation

	teachers (2), Professional ethics (1), Positive discrimination (1), Rewarding(1), Guidance (1).
<b>10th Research Question</b>	Being an example person (8), Being a role model for students (7), Being appropriate to the school (5), Arrangement of the dress (4), Professional values (3), Being ethic (3), Being respectful (3), Wanting (2), Same culture agreement (2), Importance of the private life (2), Family attitudes (1), Being fair (1), Attitudes and ideas (1), Sentimental values (2).
<b>11th Research Question</b>	Sharing with teachers (6), Doing long term evaluations (5), Evaluation at the end of the term (4), Feedback problems (4), Doing annual evaluations (4), Adding new criteria (3), Doing monthly evaluation (2), Evaluation without force (2),Forms special to the schools (2), Opinions of assistant administrators (1), Classical evaluations (1).
<b>12th Research Question</b>	Not getting parents' opinions (8), Getting students and parents' opinions (5), Not getting students' opinions (5), Offending parents' attitudes (3), Getting inspectors' opinions (2), Career and improvement criterion (2), School administration is enough (1), Colleague evaluation (1), Evaluation of high school students (1), Objectivism (1).

With the data gotten, creating codes and categorizing them was not possible. With the codes specified, the themes are needed to be found. By analyzing the data gotten by interviews with administrators, the codes were collected into 5 themes and on Table 2 were written as below:

**Table 2: Themes**

<b>Theme 1</b>	<b>Planning of Education at Schools and Organizing Educational Environment</b>
<b>Theme 2</b>	<b>The Ability of Teachers' Motivation and Using Opportunities of School Environment</b>
<b>Theme 3</b>	<b>Time Management and Using The Suitable Method For the Lessons</b>
<b>Theme 4</b>	<b>Evaluating the Students and Behaving According to School Policies</b>
<b>Theme 5</b>	<b>Professional Qualification- Competence and the Condition of the Criteria of Teacher Evaluation</b>

At the stage of coding by theming, the basement of doing according to codes and themes done with data was used. The researchers divided each theme into 10 sub-themes, which are appropriate to 5 theme in accordance with data. On Table 3, themes and sub-themes are given:

**Table 3: Themes and Sub-themes**

<b>Themes</b>	<b>Sub-themes</b>
<b>Planning of Education at Schools and Organizing Educational Environment</b>	1. Lost of Individuality Because of Using Ready Plans, Not Paying Attention to the Districts and Students
	2. Using Technological Opportunities and Materials and Hardworking Teacher Attitudes
<b>The Ability of Teachers' Motivation and Using Opportunities of School Environment</b>	1. Get Use of Environmental Opportunities and Motivate Students by Understanding Them
	2. Communication Problems and The Need of Inservice Education
<b>Time Management and Using The Suitable Method For the Lessons</b>	1. Use of Technology, Time Management and The Problem of Entrance and Exit Time To the Lessons
	2. Choosing Appropriate Method and Technique to The Student- Subject- Daily Life
<b>Evaluating the Students and Behaving According to School Policies</b>	1. Transparent Student Evaluations and Giving Feedback
	2. The Ability of Taking Decisions with Institutional Loyalty and Protecting The Benefits of the School
<b>Professional Qualification- Competence and the Condition of the Criteria of Teacher Evaluation</b>	1. Considering Professional Qualifications and Role Model Teachers
	2. Long Term Teacher Evaluations and Taking Student- Parent Views into Consideration

At the last step, data which were collected and explained in detail was interpreted by the researchers. At the same time, some results were tried to be found out. In qualitative researches, researchers' ideas and inferences are important because the researchers are close to the data. According to the themes and sub-themes, the findings and some opinions of the administrators are as follows:

### **3.1. Planning of Education at Schools and Organizing Educational Environment**

#### **3.1.1. Lost of Individuality Because of Using Ready Plans, Not Paying Attention to the Districts and Students**

According to administrators, it is found out that teachers are generally getting their plans by using internet and copying and pasting them (4/15). Administrators indicate that teachers generally use ready plans (4/15), teachers do not pay attention to students while preparing the plans (4/15), they prepare plans without any care on differences because of district (3/15) and some lazy teachers are not enough to prepare the plans. Some administrators' opinions are as follows:

*"Nowadays, most of the plans which are prepared by the teachers are gotten by the educational websites or these are the standard plans which are prepared by some publishing houses..." (M3).*

*"...Because of the students number are high in some classes, I don't think that individual differences are cared about while teachers are preparing the plans..." (M9).*

#### **3.1.2. Using Technological Opportunities and Materials and Hardworking Teacher Attitudes**

Administrators state that they pay attention to using technology on their evaluations (4/15), on the evaluations teachers who pay attention to using technology are successful (2/15). Administrators on the research indicate that teachers who are using different methods and techniques to ease learning and teachers who are really hardworking are more successful both on the evaluations and on their occupations. Some administrators' opinions are as follows:

*"...There is a special role for the teachers to improve a new material and use it in the class. Each one of these are one criteria on the evaluation process for the administrators..." (M1).*

*"...A teacher should pay attention the modern day to arrange the educational environment and use technological equipments and the teacher should always be in the struggle for improving himself..." (M2).*

### **3.2.The Ability of Teachers’ Motivation and Using Opportunities of School Environment**

#### **3.2.1.Get Use of Environmental Opportunities and Motivate Students by Understanding Them**

The administrators who talks about the importance of teachers’ use of environmental opportunities (6/15), indicate that teachers who understand the students and use technology motivate students easier than other teachers (3/15). Some administrators’ opinions are as follows:

*“Using technological improvements to the educational environment help teachers to motivate students more easily ...”(M5).*

*“...I think a teacher has the responsibility to get the students to be willing to the lessons, not just teaching a lesson because each student can easily learn if he is willing to learn...” (M4).*

*“...Distinguishing one lesson or subject’s importance to the student’s life will motivate students in terms of aimed gains ...”(M2).*

#### **3.2.2.Communication Problems and The Need of In-service Education**

Communication problems comes first in the list of the problems that teachers have with parents (5/15), that teachers have with the students (4/15), that teachers have with colleagues (3/15), For this reasons, the administrators’ opinions in order to have in-service training about “communication” (7/15) are as follows:

*“...During the workshop periods, current education should be given to the teachers and administrators by the subject matter experts. This subject can be given to the teachers under some different titled in-service training. Thus, both the language may be ensured to be used accurately and precautions for the corruption of the language which has got fast with the technology may be taken...” (M6).*

### **3.3. Time Management and Using The Suitable Method For the Lessons**

#### **3.3.1. Use of Technology, Time Management and The Problem of Entrance and Exit Time To the Lessons**

The administrators who state the importance of time management during the inspections (4/15) indicate that the teachers can use time more affectively by means of technology (5/15). While on the one hand administrators indicate that teachers use time more affectively, on the other hand they state that teachers have problems with the entrance and exit time to the lessons and using time for the benefit of students. Some administrators’ opinions are as follows:

*“Time management is important for teacher evaluation because the data and information on their hand is clear. Subjects are clear. The teacher needs to evaluate the time period when to teach this subjects to the students with regard to time. Whiling evaluating this, the time management is one of the essential things for the administrators...” (M1).*

*“Entrance and exit time to the lessons is generally a problem for all schools. Teacher does not spend much time with the exit time of the lessons and immediately rests. With the entrance bell to the lesson, the teacher goes on tea break in the teachers’ room and without feeling any upset, takes other teachers’ education time. (M5).*

#### **3.3.2. Choosing Appropriate Method and Technique to The Student- Subject- Daily Life**

According to the administrators, teachers use of appropriate method to the students (7/15), to the lesson and subject (3/15),teachers use of adaptable method to the daily life (2/15), is very essential for them. Some administrators’ opinions are as follows:

*“Not using appropriate method and technique to the level of students make learning and teaching process difficult and longer. The easiest way to teach is learning by doing. Students should feel that he needs what he learns and can use what he learns in daily life...” (M3).*

*“That teacher’s use of appropriate method to the class and circumstances of education environment is important make students like the lesson and get over more in a short time ...” (M6).*

### 3.4. Evaluating the Students and Behaving According to School Policies

#### 3.4.1. Transparent Student Evaluations and Giving Feedback

On the evaluation processes, the school administrators who look for teacher's being transparent while evaluating students (7/15); states that students must be reported for the results (6/15) and the evaluations must be done objectively (4/15). Some opinions of the administrators as follows:

*"I see that our teachers are transparent on their student evaluations except some circumstances. In this respect, it is observed in our school that if the step of giving feedback is skipped, the acquisition which is aimed takes time and may not be gained..." (M8).*

*"...It is expected from the teachers to improve themselves in terms of giving feedback to students. Teachers are not giving enough feedback to inform students about why they give points and what students need to do..." (M13).*

#### 3.4.2. The Ability of Taking Decisions with Institutional Loyalty and Protecting The Benefits of the School

The administrators who state the importance of institutional loyalty (3/15), indicate that the common decisions gotten inside the school will provide positive returns to the evaluations and will ensure unity and solidarity of the school (5/15). At the same time, the teachers who protect the benefits of the school will always be supported positively (3/15) and gain of these teachers will be more (3/15). Some opinions of the administrators are as follows:

*"...If the teachers did not protect and contribute to the values of the school, the administration of the school's attempt to develop any projects or attempts to improve itself, it would not survive. The reason of is that the teachers do not have the institutional loyalty and policy of the school..." (M1).*

*"...We as school administrators have given particular importance on the harmony of the teachers in themselves and with the administration of the school because we are all and if one part is absent, we are aware that other parts will scatter within time. Therefore, we have all learned to unite to all kinds of criticisms..." (M15).*

### 3.5. Professional Qualification- Competence and the Condition of the Criteria of Teacher Evaluation

#### 3.5.1. Considering Professional Qualifications and Role Model Teachers

The administrators who indicate the importance of teacher's being an example person to the students (8/15), state the teachers who are role model for the students are treated with great respect during the evaluations (7/15). Teachers who follow the rules of the school (5/15), are careful about his/her wearing (5/15), give importance to professional values (5/15) are at the top of list on the evaluations. Some opinions of the administrators are as follows:

*"The most important person to take as an example is the teacher for students. Teacher should have the characteristic of an example person. From his wearing to the words he uses everything is important. While evaluating a teacher, his/her being a gentle woman/gentle man is important. Then, her/his attitude to the environment and colleague attitudes come. However, the most important thing is her behaviors towards the students, which is very important for education. Respecting to the rights of the students and seeing them as people is the most important thing." (M3).*

*"A teacher is a teacher in all point and place of the life. Being a teacher as a profession is a profession which always looks for being an example person. I think with position, words and actions, with wearing, a teacher should always protect the prestige the profession, being a teacher ..." (M9).*

#### 3.5.2. Long Term Teacher Evaluations and Taking Student- Parent Views into Consideration

The administrators who state the importance of evaluating teachers not in short term, but in long term (5/15), are uncertain about sharing the results with the teachers. While (6/15) administrators see no disadvantage of sharing, (9/15) administrators think that it may disturb the peace within the school.

About taking parent and student's views to the evaluations, most of them state his/her disagreement (8/15). Some opinions are as follows:

*"I think that the views of parents and students should not be taken into consideration on the evaluations because parents may show offending and backbreaking behaviors. Teachers are always wrong, but students are right. For this reason, I do not think that there will be a positive attitude towards the evaluations..." (M10).*

*"...A teacher cannot be evaluated in just one lesson hour. His/her living and the process is confronted as an important criterion for evaluation." (M4).*

#### **4. Discussion and Conclusion**

In accordance with the administrators' opinions, teachers are generally downloading the plans from the internet and using these unsubjective plans in their lessons. In this respect, teaching based on students and strategies which focus on the differences between regions cannot be talked. We can say that teachers see preparing annual and daily plans as extra workload. Also, we can say that, teachers who do not use technology to be practical, do not use appropriate materials to the lessons do not make an effort for the success of the students. In this respect, there is a similarity with other some researches about planning. According to some researches, teachers see preparing plans as extra work and plans are usually taken from the official curriculum as they are and therefore there is no reflection of the teacher (Ozturk, 2012:297; Tasdemir, 2006).

It has been found out that a teacher should be hardworking and use all the possibilities for the lesson. Teachers are responsible for taking students' attention to lesson to be successful on the evaluation. If a teacher does not use the possibilities of the environment, teacher's success on the evaluation cannot be waited for. The teacher who understands the students and come to the lesson accordingly are the teachers who prepare her/his lessons according to the students, uses the best methods in his/her lessons and whose communication with students is at high level. It can be said that teachers who are careful about entrance and exit time to the lessons, give special time to the students and parents are given great importance by the administrators. The teachers who come and exit from the lesson on time will be an example for the students. At the same time, they will clear the administrators who evaluate them about the methods they use are based on daily life and students.

The teachers who are careful about the criteria of the profession about wearing, being a model for students and even parents, will ease the work of evaluator administrators and improve the culture of the school. In the research done by Sahin (2011:254) about the effective teachers' attitudes, it is found out that it is important for a teacher to have good social ethics and be a model with his/her behaviors. The teachers who are objective and transparent on student evaluations will get positive results on their own evaluations and enhance the success of students by giving feedback to the students. The teachers who are loyal to the school which they work, who protect the benefits of the school and at the same time who work for improving the culture of the school will have more positive evaluations.

Doing the evaluation not only one time in a year, but in a long process each term will make the teacher ready for all time and will improve the quality of education, school, teacher, everything. It is clear that we are not ready to take the views of the parents and students yet. However, No disadvantage of taking views of parents and students into consideration is seen. In the research done by Altun and Memusoglu (2008:19), teachers, administrators and supervisors have stated the disadvantages of taking parents and students. They think that there will be a negative atmosphere within the school and it will cause more problems It shows that we are not ready to take the opinions of students and parent's views.

#### **5.Recommendations**

The administrators who do the evaluations of the teachers in the school can get sufficient inservice training. The administrators should know when and how to evaluate the teachers in terms of the teachers branch. At the same time, it can be asked for some help from the inspectors within the evaluation process. That doing the evaluation of the teachers in a long process will be the most beneficial update in the process. The teachers who are ready to be inspected not just for some days but

for always will expand the quality of teaching. The criteria of the evaluation can be updated one by one appropriate to the process of teaching, modern days and the changes in the society.

## 6. References

- Altun, S. A., & Memisoglu, S. P. (2008). Performans degerlendirmesine iliskin ogretmen, yoneticisi ve mufettis gorusleri. *Kuram ve Uygulamada Egitim Yonetimi Dergisi*, 14(1), 7-24.
- Aydin, I. (2013). *Ogretimde denetim*. Ankara: Pegem Akademi.
- Altuntepe, O.(1999). Ortaogretim kurumlarinda ogretmen performansinin degerlendirilmesi, *Dokuz Eylul Universitesi: Sosyal Bilimler Dergisi*, 1 (1), 81-106.
- Basaran, E.(1991). *Orgutsel davranis*. Gul Yayinevi: Ankara.
- EARGED. (2006). *Okulda performans yonetimi modeli*. Ankara: Milli Egitim Basimevi.
- Helvaci, M. A. (2002). Performans yonetimi surecinde performans degerlendirmenin onemi. *Ankara Universitesi Egitim Bilimleri Fakultesi Dergisi*,35(1-2), 155-169.
- Kocak, R. (2006). Ogretmen performans degerlendirme envanteri (OPDE) gecerlik ve guvenirlik calismasi. *Kuram ve Uygulamada Egitim Bilimleri*, 6 (3), 779-808.
- OZTURK, I. H. (2012). Ogretimin planlanmasinda ogretmenin rolu ve ozekliigi: Ortaogretim tarih ogretmenlerinin yillik plan hazirlama ve uygulama ornegi. *Kuram ve Uygulamada Egitim Bilimleri*, 12(1), 271-299.
- Peterson, K. D., & Peterson, C. A. (Eds.). (2005). *Effective teacher evaluation: A guide for principals*. Corwin Press.
- Sabuncuoglu, Z. (2012). *Uygulama ornekleriyle insan kaynaklari yonetimi*. Istanbul: Beta Basim
- Sahin, A. (2011). Ogretmen algilarina gore etkili ogretmen davranislari. *Ahi Evran Universitesi Egitim Fakultesi Dergisi*, 12(1), 239-259.
- Stronge, J. H. (2006). *Evaluating teaching: A guide to current thinking and best practice*. Corwin Press.
- Tasdemir, M. (2006). Sinif ogretmenlerinin planlama yeterliklerini algilama duzeyleri. *Egitim Bilimleri Dergisi*, 4(3), 287-307.

# Investigation of Teacher Opinions on Crisis Management in Primary and Secondary Schools

Ismail Erol, Ismail Karsantik

## 1. Introduction

Looking at the definition of the crisis in detail, it is a situation that is not correct and requires radical decisions. They are situations that suddenly break down the normal functioning of a structure and suddenly emerge. It requires the care of the owner and the people who manage the situation. The crisis situation threatens not only the continuity but also the future of the institution in which it emerges. It can destroy the controversy that arises with other institutions and prevent it from becoming productive. It has a very effective potential for the development or differentiation of the institution (Vergiliel, 1996, p.3).

Concept of crisis might be conceptualized as events that have become prominent and which have not been noticed before, affecting the functioning of institutions or structures and their work (Jimenez, 2001 p. 54). The crisis situation is a disproportionality affecting the activities of the organizations and the companies and their continuous work. It is the situation that puts the institution's goals at risk and takes precautions against it, at the same time providing short time while taking the measures, and most importantly when it arises it puts the concerned decision organs into the trouble of deciding and managing the situation (Irvine, 1987, pp. 36-37).

Time is not a friend in case of crisis. Every time it emerges and continues, the crisis continues to hush the institution and to multiply in the institution (Luecke, 2008, pp. 107). This is the beginning of the crisis. When a crisis is detected in the emergence, the crisis situation, just like illness or the treatment of the disease, can easily be eliminated (Keown-McMullan, 1997, p.6). One of the most important elements for resolving the crisis rapidly is the rapid identification of the signs of crisis. Just as early diagnosis is important for a disease, early diagnosis is crucial in cases of crisis. In the event of a crisis, many of the administrators make incorrect decisions in different and unnecessary situations and act without consulting the employees. For this reason, tightening of the control mechanism in the organizations, the operation in the management and an increase in the intermediate levels, solidification in the rules, an increase in the rules of procedure can occur. Very strict supervision can cause problems for self-sustaining and hardworking individuals (Realin, 1999, p.36).

Crisis management is about deciding which ways to implement and enforce in order to be able to identify the most appropriate solution for quality and situation, and to recognize how this process will be managed (Fink, 1980, p.83). The concept of crisis management is the process of making preliminary analysis by recognizing the symptoms in the face of a crisis, and planning the work to be done in order to defeat the crisis by giving the least loss in the crisis period (Pearson, C. M. and Clair, J. A., 1998, p.64). As an example, the hurricane of Katrina, which took place in New Orleans in USA in 2005, is clearly a prefix to this situation. At the end of the storm, many buildings and public institutions became damaged at the same time, education and training activities ceased and became unsustainable. The biggest lesson and note taken by schools for crisis management in the event of a tornado is the need to be prepared for natural disasters and disasters (Lipka, 2005, p.28). One of the first situations that should be implemented is to prepare the plan and operation related to crisis management. There are two basic questions that have to be taken into consideration when creating these plans (Allen and Ashbaker, 2004,139):

- a) Who should be appointed and trained as an intervention team in case of crisis?
- b) Which training model is the most appropriate and can be processed?

According to Allen and Ashbaker (2004, p.139) it is very important to meet the physical and psychological needs of the students at the first stage in the crisis time. Therefore, it should be rigorous when determining the members of the intervention team created according to the prepared plan. After



the persons in charge of the crisis management are identified, the task distribution should be made and the tasks should be explained in detail. Different plan and activity charts should be created for each different crisis situation and the procedures should be certain. As a result, functioning should be resolved without making a clear decision at the time of crisis (Kennedy, 2004).

In a crisis situation, many of the administrators and teachers make misleading decisions in different attitudes and act without consulting their colleagues. For this reason, tightening of the control mechanism in the educational institutions, solidification of the rules can occur. Crisis management helps to decide which ways to implement in order to determine the most appropriate solution to the situation, and to realize how these situations will be managed.

In order to effectively manage conflicts in the group during crisis times, administrators need to consider the following points (Tack, 1994, pp. 35-39):

- a) Rather than acting without will, every event should be handled within its own circumstances.
- b) Attention should be given to the group and it should be assumed that the team can work together.
- c) It should be remembered that in times of crisis, words may be more striking than movements.
- d) Once the problem is diagnosed, it should be considered that it cannot be resolved over time.
- e) If the attitude of the team is to be changed, positive support should be applied, not a threat.
- f) The manager team should never forget that it is a job.

The aim of this study is to evaluate the approaches and perceptions of primary and secondary school teachers to crisis situations experienced in their institutions. For this purpose, the following questions were sought for an answer:

- a) What are the perceptions of teachers' level of crisis management?
- b) Is there any difference in teachers' perceptions of crisis management according to their gender?
- c) Is there any difference in crisis management skills according to the years of experience of teachers?
- d) Is there difference in crisis management skills according to the teachers' teaching field?
- e) Is there any difference in the techniques of the crime intervention according to the teachers' ages?

It is thought that the results obtained in the study will contribute to the policy to be developed in crisis management.

## 2. Method

Qualitative research method was used in the study in which the approaches and perceptions of primary and secondary school teachers who are working in Kocaeli and Tekirdag provinces towards crisis management were tried to be determined. Phenomenology method was utilized in the study that aimed at evaluating the perceptions of primary and secondary school teachers to the crisis situations experienced in their institutions. Phenomenology is a qualitative research design used to describe how certain phenomena are perceived, understood, sensed, and experienced by a person (Patton, 2002). In the study, data were collected through semi-structured interview, which is patterned as phenomenological and suitable for qualitative research. By this way, it is possible to determine the participants' experiences, attitudes, ideas, intentions and reactions in the interview process (Yildirim ve Simsek, 2011).

The study is composed of 20 primary and secondary school teachers working in the provinces of Kocaeli and Tekirdag in the academic year of 2015-2016. Since it is impossible to reach all the teachers in the study population, a study group was preferred. Characteristics of the teacher participants are demonstrated in Table 1.

**Table 1. Characteristics of Teacher Participants**

<b>Field</b>	<b>Age</b>	<b>Years of Experience</b>	<b>Level</b>	<b>Gender</b>	<b>Code</b>
<b>Science and Technology</b>	35	9	Secondary	M	M1
<b>Science and Technology</b>	42	17	Secondary	M	M2
<b>Turkish Language</b>	36	11	Secondary	F	M3
<b>Primary School Teacher</b>	37	10	Primary	M	M4
<b>Primary School Teacher</b>	37	12	Primary	M	M5
<b>Primary School Teacher</b>	42	17	Primary	F	M6
<b>Primary School Teacher</b>	45	20	Primary	M	M7
<b>Primary School Teacher</b>	41	14	Primary	M	M8
<b>Mathematics</b>	40	14	Secondary	F	M9
<b>Turkish Language</b>	42	16	Secondary	M	M10
<b>Primary School Teacher</b>	56	31	Primary	F	M11
<b>Primary School Teacher</b>	55	30	Primary	F	M12
<b>Turkish Language</b>	55	30	Secondary	M	M13
<b>Turkish Language</b>	60	36	Secondary	F	M14
<b>Mathematics</b>	57	30	Secondary	F	M15
<b>Mathematics</b>	50	26	Secondary	M	M16
<b>Primary School Teacher</b>	50	26	Primary	M	M17
<b>Primary School Teacher</b>	53	28	Primary	M	M18
<b>Religious Culture and Moral Education</b>	48	23	Secondary	M	M19
<b>Science and Technology</b>	51	27	Secondary	M	M20

It is planned to make 20 teachers participate in the study by applying maximum variation method. Data were collected with face-to-face interviews through semi-structured interview forms. Semi-structured interview questions were formed by reviewing the literature and taking expert opinions. In order to make the interviews suitable for the purpose of the study, the literature describing the method of interviewing was examined and necessary precautions and measures were taken in order to ensure the most appropriate research conditions by emphasizing the importance of scientific interview methods. The research interviews lasted 30-45 minutes on average and the data obtained from the teachers were analyzed by content analysis.

The collected data must first be conceptualized and these concepts emerging afterwards should be regularized. Then the themes should be opened up in content analysis (Yildirim and Simsek, 2011, p.45). In the study, an attempt was made to directly quote interview data to ensure internal reliability. In qualitative research, validity and reliability are explained by Guba (1981) as credibility, transferability, consistency and verifiability. In this study, purposeful sampling and detailed description were made for transferability, data were analyzed by two researchers for consistency and expert opinion was obtained for verifiability.

### 3. Findings

Findings obtained as a result of the research are classified as five (5) main headings. The classification from the interviews is as follows:

- a) Teachers' Crisis Management Perception Levels
- b) Crisis Management and Gender Context of Teachers
- c) Crisis Management Skills By Teachers' Years of Experience
- d) Crisis Management Skills by Teachers' Teaching Fields
- e) Teachers' Age Levels and Crisis Management Context

#### Teachers' Crisis Management Perception Levels

Teachers (19/20) who participated in the interview expressed the occasional crisis situations in their schools. At the same time, these teachers (15/20) stated that they perceive crisis situations in their schools and accordingly take measures in their classes and schools. While the primary school teachers (6/9) stated that there were student-led crises in their schools, the secondary school teachers (7/11) stated that they experienced management-led crises. Teachers (16/20) who participated in the research expressed the need for in-service training for the development of perception skills of teachers and administrators in crisis management.

*"In schools, as in every institution, there are occasional troubles and crises. It is normal for crises to happen in every environment where people are. What is important in educational institutions is to overcome it" (M3).*

*"We spend time with the school from the school. Now I know what happens with the experience of years. For this reason I am prepared for crisis situations" (M17).*

*"Generally, the difficulties stem from the students. We cannot keep them in place ... " (M11).*

*"In schools, managers think that they should improve their managerial skills and keep themselves up to date with crisis situations that happen in schools" (M1).*

*"Crisis management is not the duty of the employees in school, I think. Crisis management starts with conscious family ... " (M9).*

#### Crisis Management and Gender Context of Teachers

Of the teachers who participated in the interview, 7 were female and 13 were male. The teachers interviewed (14/20) indicated that female primary school teachers were more successful in classroom management and crisis management, while the male teachers (15/20) at secondary school level was more successful in managing students and managing difficulties and overcoming crisis situations. Teachers (17/20) stated that gender is not very important in crisis management skills and intervention techniques in school management.

## Investigation of Teacher Opinions on Crisis Management in Primary and Secondary Schools

*"In classroom teaching, I can easily say that even though I am not a male, the female teachers know the students and are more successful in solving the problems experienced in class" (M7).*

*"I think as our age grows, our children are increasingly in direct proportion to their problems. I think that students from male administrators and teachers are attracted more" (M3).*

*"Management is a talent. I know ladies like that, more successful than most men. Fixed with experience. I am absolutely dependent on crisis management; I depend on experimentation. It is not gender" (M13).*

### **Crisis Management Skills According to Teachers' Years of Experience**

Five of the interviewed teachers have 30 years and over, 4 of them have 25 years and over, 2 of them have 20 years and over, 3 of them have 15 years and over, 5 of them have 10 years and over, and 1 of them has under 10 years of experience. The teachers (16/20) stated that experience is important in crisis management, others voiced that education is more important than experience (4/20). The interviewed teachers (16/20) stated that the experiences were important in the school administration and during the crisis intervention times.

*"I gave 30 years to this profession. I always say around. If I worked with a carpenter, I figured out which tree was covered when I picked up a wooden plank. Teacher is like that. When I look at a student now, I can see if there is light in him" (M11).*

*"Experience is always important. The experience of teachers is important to know the time spent at school, to get to know the students closely, to spend time with them, and to identify and take precautions in school" (M20).*

### **Crisis Management Skills by Teachers' Teaching Fields**

Of the teachers who participated in the interview, 9 are primary school teachers, 4 are Turkish language teachers, 3 are science and technology teachers, 3 are mathematics teachers, and 1 is a religious culture and moral education teacher. While the teachers (13/20) expressed that primary school teachers were more successful in school management in crisis management (7/20), they pointed out that the teaching field in crisis management was not very important.

*"They are the ones who spend more time with the students. A student is studying from 1st to 4th grade. They naturally experience in crisis and classroom management (M19).*

*"In crisis management, I do not think the branch is very important. The important thing is experience (M10).*

### **Teachers' Age Levels and Crisis Management Context**

9 of the interviewed teachers were 50 years old and over, 7 were 40 years old and over, and 4 were 30 years old and over. While some teachers (11/20) stated that age is important in crisis resolution and management skills, others (9/20) stated that experience is more important than age. Most teachers (17/20) emphasized that not only age, but also the education received and the experienced person is important in crisis management.

*"Age brings maturity and calmness together. It improves people's perspective on events. For timely intervention, the share of age in mind is great" (M18).*

*"I am only aged, and I cannot imagine that you will achieve success in the stages of crisis management. Experience is also important" (M13).*

*"Education, experiences, crisis situations that have been in school before are the real experiences. If a person does not experience these experiences, he cannot succeed in crisis management" (M4).*

## **4. Discussion and Conclusion**

According to the results of the study, many of the teachers are predicting crisis situations and taking measures against them. While primary school teachers describe the source of the crisis as students, secondary school teachers say it is based on management. A large number of teachers express the need

for in-service training of teachers and administrators for crisis management. Also, in school administrators, teachers who say that gender is not important in crisis management, have stated that classroom management is more effective for female primary school teachers in primary school and male teachers in secondary school.

The greatest responsibility for the management of schools falls on the school principals. Taking this into consideration, it is necessary for school principals to determine the methods to be applied in order to remove the crisis and to reduce the possible damage of the crisis to a minimum level. According to the findings, the most important task for the school principal is to predict the crisis and resolve it. The school principal should make a decisive contribution to the overcoming of the crisis in the school with his constructive behavior and attitude towards school. Similarly, Demirtas (2000) mentioned the importance of managerial competencies in crisis management in his study. The manager should direct the crisis by resolving it and by evaluating the events in a holistic approach, structurally based on culture, management, and resource use. In addition, for effective crisis management and planning, joint work with internal and external stakeholders should also be undertaken (Ritchie, 2004, p. 680).

Teachers say that experience is important in crisis management and at the same time they are more effective with in-service training experience. The interviewed teachers stated that the experiences are of great importance in school administration and crime intervention techniques.

It can be stated that the positive side of the crises may also be the result of taking the lessons from the crises and the least possible damage from the possible new crises. It can be said that the crises give schools the ability to gain experience and new experience. Similarly, Okumus (2003) discussed the positive aspects of crises. At the same time, it provides appropriate opportunities for organizations to observe structures, policies, social situations and operations (Boin, 2004).

A large majority of teachers say that the teaching field is not important in crisis management, but again a large majority say primary school teachers are more effective in crisis management. Emphasizing that age is not important, teachers have reported that age-related experience is very important in crisis management.

In crisis management, managers and teachers must have certain abilities. Qualifications required by managers in crisis management can be listed as follows:

- a) Getting the crisis signals.
- b) Preparation and protection of the cruiser.
- c) Be able to make effective decisions in crisis management process.
- d) To be able to use authority in crisis management process.
- e) Planning crisis management process.
- f) To organize the crisis management process.
- g) To be able to communicate in crisis management process.
- h) To be able to provide coordination in crisis management process.
- i) Be able to control the crisis management process.
- j) Be able to provide transition to normal state.
- k) Learning and evaluation in crisis management process.

Besides all of this, perhaps the most important thing to say is knowing how to take lessons. Because only those who know how to take lessons can make healthy plans for the future (Demirtas, 2000).

## 5. Suggestions

Based on the results of the research, seminars can be given to the teachers and administrators on the factors that may cause the crisis in the schools. A "crisis management plan" for possible crises can be created. Seminars and courses can be organized for teachers on writing this plan and crisis management. Preliminary studies on the identification and resolution of possible crises can be made in schools. The development of measurement tools of crisis management skills in accordance with the different stages of the education system can make the crisis management process even easier. This should be emphasized on scale development studies. Schools should have the ability to intervene as a planned and trained team against crisis situations as it should be in other teaching activities. It is

necessary to ensure that parents, children, young people feel more secure in their school and around the school.

## 6. References

- Allen, M., & Ashbaker, B. Y. (2004). Strengthening schools. *Intervention in School and Clinic*, 39(3), 139-146.
- Boin, A. (2004). Lesson from crisis research. *International Studies Review*, 6(1), 165-194.
- Demirtas, H. (2000). Kriz yönetimi. *Kuram ve Uygulamada Egitim Yonetimi*, 6(23), 353-373.
- Fink, S. (1980). *Crisis management*. New York: American Management Association.
- Guba, E. G. (1981). Criteria for assessing the trustworthiness of naturalistic inquiries. *Educational Communication and Technology Journal*, 29, 75-91.
- Irvine, R. B. (1987). What's a crisis, anyway? Retrieved from <https://www.questia.com/magazine/1G1-19746597/what-s-a-crisis-anyway>.
- Jimenez, D. (2001). When you are the headline: A guide to understanding crisis management. *Franchising World*. 33(3), 1-3.
- Kennedy, M. (2004). Preparing for disaster. *American School and University*, 76(11), 135 -139.
- Keown, C., & McMullan. (1997). Crisis: When does a molehill become a mountain? *Disaster Prevention and Management*, 6(1), 4-10.
- Lipka, S. (2005). After Katrina, colleges nationwide take a fresh look at disaster plans. *Chronicle of Higher Education*, 52(8), 28-30.
- Luecke, R. (2008). *Felaketleri onleme becerisi, kriz yönetimi*. Harvard Business Essentials. (Cev: Onder Sarikaya). Istanbul: Yaylacik Matbaa.
- Okumus, F. (2003). Isletmelerde kriz yönetimi ve krizlerin isletmeler uzerine olasi etkileri. *Ataturk Universitesi Iktisadi ve Idari Bilimler Dergisi*, 17(1-2), 203-212.
- Patton, M. Q. (2002). *Qualitative research & evaluation methods*. (3rd ed.). Thousand Oaks, CA: SAGE Publications, Inc.
- Pearson, C. M., & Clair, J. A. (1998). Reframing crisis management. *The Academy of Management Review*, 23(1), 59-76.
- Realin, J. A. (1999). *Kulturlerin catismasi*. (Cev: K. Tuncay). Istanbul: Turkiye Is Bankasi Kultur Yayinlari.
- Ritchie, B. W. (2004). Chaos, crises and disaster: a strategic approach to crisis management in the tourism industry. *Tourism Management*, 25(6), 669-683.
- Tack, P. B. (1994). *Kriz zamani yonetim*. (Ceviren: Yakut Guneri). Istanbul: Ilgi Yayıncılık.
- Vergiliel, M. T. (1996). *Kriz donemlerinde isletme yonetimi*. Bursa: Ekim Kitapevi.
- Yildirim, A., & Simsek, H. (2011). *Sosyal bilimlerde nitel arastirma yontemleri*. Ankara: Seckin Yayıncılık.



# Teachers' Perception of Justice in Decision Making Process

Bertan Akyol, Mehmet Ulutas

## 1. Introduction

Organizational justice means employees' perception of fairness related to workplace procedures, interactions and outcomes. This term includes three sub-dimensions which are distributive justice (equal distribution of outcomes to all employees), procedural justice (fairness of criteria leading the decisions of outcomes) and interactional justice (fairness perceived related to the interactions in an organization). The perception of justice is required to be considered seriously by the management of an organization to carry the whole management processes successfully. The existence of justice is crucial for all the processes in management, but it becomes more significant for decision making process as it is the focus point of the other managerial facilities.

Decision making is adapting to the form of a certain activity and taking responsibility on behalf of others, promising and wanting other people to support their decision. Decision-making is also the heart of management. The nature of the management process is determined by decision-making (Aydin, 2010). Decision making process is also used to make changes in the organization, block or solve any conflict and affect members of organization. The organization's life depends on the accuracy of the decisions it makes. Decision making process resembles the process we call "problem-solving". It may be necessary to use a number of different methods to make a decision in solving problems. These models such as optimizing and satisficing decision making, muddling and scanning, garbage and politics, practice cases, a comprehensive model, a simplified model (Hoy & Tarter, 1995; Arslan, 2018). Solving the problems which may emerge from a little injustice in an organization is among the main tasks of the management. From the point of distributive justice, employees who are members of an organization may feel that distributions in the organization are not done fairly among different employees and they may think that there is an injustice right there. This situation may cause a feeling of anger towards the organization and may lead to distrust against the managers. Besides, these employees may think that their co-workers do not deserve their income. Because of this, employees expect all people in the organization get what they deserve and they think only in this way they can work with fair managers in a fair organization. If an output or a decision related with it is perceived as unfair and in spite of their contribution to the organization they continue to feel that they are not offered deserved income, feelings of anger and aggression are likely to emerge (Akyuz, Demirkasimoglu, & Erdogan, 2013; Greenberg & Lind, 2000).

Organizational management and decision making means two concepts in the same category (Besler, 2009; Bakan & Buyukbese, 2005). The quality of the decisions made by the organization includes organizational dynamics. As the organizations grow and get more complex, decision – making mechanisms become the most central part. That's why managers are expected to evaluate the alternatives about the decisions in the most rational way and make the most appropriate choices for both the organization and its stake-holders. Moorman (1991) states that employees' trust and loyalty to each other and the organization are in direct proportion to perception of justice in the organization and justice gives a direction to the behaviors of employees. When they feel that the managers who are decision – makers treat them fairly, it's clearly seen that they support taken decisions within the organization. On the other hand, when they see that a lack of justice is increasing, the rate of compliance with decision decreases.

If the process which is related to taken decisions within the organization corresponds to employees' income in a fair way, it can be seen as a success of the management. The main purpose of the managers is to keep the organization alive and to reach the goals. In doing so, it is necessary to consider the human factor (Kaya, 1996). It must be known that being a member of an organization



which is managed using fair decision – making process affects perceptions of employees positively for both the organization and managers. One of these perceptions is trust. Blau's (1964) social change theory reveals the trust change of profits between two people or groups and it's important for continuous social relationships. In terms of organization, trust has a very important impact on an organization's living and endurance (Hoy & Miskel, 2010). Experimental studies on this subject show that organizational justice affects employees' trust in the managers and organization. In the same way, Colquitt, Greenberg and Zapala (2005) pointed out that not only each employee of the institution but also managers have an important role in providing all issues related to organizational justice.

Decision – making is both the most important task of the management and the administrative process which makes the management the most strategic part of the organization. The effectiveness of the management stage is not making so many decisions; it's getting results by focusing on the important ones. Succeeding in this is the most stimulating element that motivates the sense of satisfaction in the organization (Drucker, 2001). In this sense Hubbell & Chory (2008), states that understanding how the decisions are taken in the organization not only leads the employees to understand the impartiality of the decision – making procedures but also provides a sense of trust towards the managers who are decision – makers. In the opposite of this situation, employees may feel that organization procedures serve the interests of decision – makers or they are biased in some way and it causes the disappearance of perception of justice (Bies & Shapiro, 1987). For this reason, it is very important for managers to act in this respect in the internal justice. It can be said that providing organizational justice is an element of realizing trust, motivation and the objectives of the institution.

As it is understood from the information given above, perception of organizational justice for teachers is an essential factor for the quality of their performance. For this reason, this study aims to reveal teachers' perception of organizational justice on decision making process in terms of the dimensions of organizational justice; distributive, procedural and interactional.

This study also has revealed the answer of the these questions;

1. What are teachers' perceptions of justice in general as a human being?
2. What are teachers' perceptions of justice in general as a teacher?
3. What are teachers' perceptions of justice for the decision outcomes and distribution of resources in their schools?
4. What are teachers' perceptions of justice for the attitudes of their managers in terms of informing decisions?
5. What are the suggestions made by teachers for fair decision making process in their schools?

## **2. Method**

In this section, the method of research is mentioned. This section is given through the modal of research, participants, data collection tool, and validity and reliability topics.

### **2.1. Model of Research**

This study is formed through qualitative phenomenology research design. This research design gives researchers the opportunity of focusing the topic studied thoroughly and revealing the uncertain dimensions and phenomenon out (Yildirim and Simsek, 2006). For this reason, the aim of this study is to analyze teachers' perceptions of organizational justice in the decision making process of their schools in detail.

### **2.2. Participants**

Several sampling models were used in determining the study group. First, an easily accessible sampling model was used. According to this model, the district of Aydin province Efeler, where the researchers served, was selected for the study. Another sampling model that has been used in the research has been the homogenous sampling model. According to this model, the schools in Efeler, which have similar aspects in terms of number of courses, teacher characteristics and student development, were included

in the study. The participants of this study are ten class and nine branch teachers working in ten various primary schools of Aydin city center.

### 2.3. Data Collection Tool

Data of the study is gathered with semi-structured interview technique. Questions on the interview form were prepared in the light of relevant literature review. The interview form used in the study includes questions which aim to reveal the perceptions teachers' perceptions of organizational justice and its dimension (distributive, procedural and interactional) on decision making process in detail. A voice recorder has been used during the interviews with the permission of teachers. As for the analysis of the data, voice records have been typed and then classified in parallel with the questions in the form and the sub-dimensions of organizational justice. During the analysis process the teachers have been coded as T1, T2, T3, .....T18, T19. The perceptions of teachers on organizational justice in decision making process have been shown in tables with frequency by promoting with their answers for the questions.

### 2.4. Validity and Reliability

For the internal validity of study, the data gathered have been interpreted in parallel with the findings. As for the external validity of the study, the whole process of sampling technique, data collection tool and analysis of the data have been explained. Additionally, the records gathered through the interviews have been kept for the necessary explanations and questions in the future. For the internal reliability of the study, the themes have been based on literature on organizational justice and the findings gathered have been coded by other researchers in addition to the researcher of the study.

## 3. Findings

The findings of the study have been analyzed in terms of the perceptions of teachers on organizational justice and its dimension in decision making process of their schools. Teachers' perceptions of justice term in general as a human being have been grouped under the themes in Table 1.

**Table 1.** Teachers' perception of justice term in general as a human being

	Themes	f
1.	Equal chance to get rights in society	14
2.	Equality in laws	9

Firstly, what the teachers' perceptions of justice in general as a human being were asked. As it is seen in Table 1., teachers' ideas were grouped under two themes, equal chance to get rights in society and equality in laws. It has been seen that teachers generally perceive justice as a tool to get their rights in society. In this context, T3 states that "*In a society, everybody must have equal rights and justice must be in every aspect of life.*". Another idea that is parallel with T3, T8 says that "*Justice means being aware of one's own rights and being respectful for the rights of others*". As another finding shown in Table 1., teachers need justice as a guarantee for equality under laws. T2, agreeing this idea, says that "*Justice must be guaranteed by the laws and regulations, not related to the initiative of others*". In a similar way, T11 states that "*fair and unfair must be differentiated by the help of laws and regulations in a society and it must be considered as custom by very member of this society*".

Teachers' perceptions of justice terms in general as a teacher have been grouped under the themes in Table 2.

**Table 2.** Teachers' perception of justice term in general as a teacher

	Themes	f
1.	Educational laws to create justice	12
2.	Teachers' equal behaviors to all students	9
3.	Managers' equal behaviors to teachers	9

As shown in Table 2., what teachers' perceptions of justice in general as a teacher were asked secondly. For this part, teachers' ideas were grouped under three themes, educational laws to create justice, teachers' equal behaviors to all students and managers' equal behaviors to teachers. Findings in this part of the study have revealed that plenty of teachers interviewed perceive justice in their institutions as a chance to defend their rights. They believe that justice is a requirement to create a workable place. At this point, T6 expresses that *"Justice as a teacher means fairness supported by the laws and regulations of ministry of education"*. The second finding under this theme reveals teachers' attitudes to behave equally to all students in their classes. T5 says that *"Justice is the fair atmosphere in the classroom where a teacher behaves each student equally, evaluate each student equally and teach each student equally."* For this theme, a group of teachers are in need of considering their managers as the distributor of justice in the school. T16 states that *"Justice is the equal working atmosphere created by the manager ensuring the same working conditions for each teacher in the school."*

Teachers' perceptions of justice for the decision outcomes and distribution of resources in their schools have been grouped under the themes in Table 3.

**Table 3.** Teachers' perception of justice for the decision outcomes and distribution of resources in their schools

	Themes	f
1.	Decisions in assigning classes to teachers	14
2.	Decisions in distributing school-based tasks to teachers	7
3.	Decisions in distributing rewards-punishments to teachers	6

Table 3. shows that teachers' perceptions of justice for the decision outcomes and distribution were grouped under three themes, decisions in assigning classes to teachers, decisions in distributing school-based tasks to teachers and decisions in distributing rewards-punishments to teachers. The findings gained for this theme have revealed the importance of distributive and procedural justice for teachers' performance in their schools. For the distributive justice sub dimension, most of the teachers complain for the decisions about managers' ways of assigning the classes. T7 says that *"Our manager did not behave in a fair way in groping the students in the classes. He assigned all the problematic students a class and appointed me as the teacher of this class as I criticized him in the previous meeting."* In a similar way, T1 states that *"I am teacher of English. At the beginning of the academic year, our manager asked other two English teachers ideas about their wishes to select classes to teach, but not me. I am still waiting to learn the reason of this decision."* As a significant finding for the procedural justice sub dimension, according to the teachers, another problematic topic for the decision outcomes and distribution of resources in their schools is distribution criteria of school-based tasks to teachers. They generally believe that their managers do not assign the school tasks to teachers under acceptable reasons. T4 also expresses that *"There are two Turkish Language teachers in our school, but all the tasks to organize educational ceremonies are always assigned to me."* For another issue under this theme is that teachers experience problems in having faith in their managers' decisions in distributing rewards-punishments to teachers. For this point, T13 states that *"It is my seventh year in the same school. I have finished my master in my field of study and have organized many seminars to my colleagues. But I have never received of a positive statement or a reward from my manager. On the other hand, he awarded one of my colleagues with a certificate of success as her students won bronze medal in table tennis tournament"*.

Teachers' perceptions of justice for the attitudes of their managers in terms of interaction and communication have been grouped under the themes in Table 4.

## Teachers' Perception of Justice in Decision Making Process

**Table 4.** Teachers' perception of justice for the attitudes of their managers in terms of informing decisions

	Themes	f
1.	Informing decisions based on personal relations	14
2.	Informing decisions based on teachers' performances for school	8
3.	Informing decisions based on formal communication tools	2

As it is seen in Table 4., teachers' perceptions of justice for the attitudes of their managers in terms of informing decisions have been grouped under three themes, informing decisions based on personal relations, informing decisions based on teachers' performances for school and informing decisions based on legal communication tools, which gives ideas about the existence interactional justice for teachers. Findings from the interviews with teachers have revealed that teachers criticize their managers for changing the type of giving information to teachers based on their close relations with them. T17 says that *"Our manager has a good relation with some teachers out of school time and these teachers learn the decisions taken for our school earlier than us and have more opportunity to get information about the reasons of these decisions."* T12 also states that *"If a teacher has a positive relation with our manager, s/he gets the decisions taken for our school first orally from the manager and then in a written document as we get."* Teachers also believe that working so hard for the effectiveness of the school affects managers' way of informing the teacher on a positive way. T19 explains that *"I am a class teacher and I spend most of my time in my class, which prevents me doing extra work for my school. However, our manager does not want to understand this situation and consider me and the other class teachers as lazy teachers. So, we lastly get information about the decision in our school"*. Only 2 of the teachers complain about their managers' use of formal communication tools. For this point, T9 states that *"Our manager insistently announce the decisions taken in our class in formal way with the documents, which blocks us from learning the reasons of the decisions and asking extra questions about the application of decisions"*.

The suggestions made by teachers for fair decision making process in their schools have been grouped under the themes in Table 5.

**Table 5.** The suggestions made by teachers for fair decision making process in their schools

	Themes	f
1.	Fair attitudes of managers to teachers	10
2.	Teachers' right to participate in decision making process	7
3.	Necessity for managers to undergo management training	4

Table 5. shows that teachers' suggestions for fair decision making process in their schools have been grouped under three themes. Firstly, most of the teachers suggest that their managers should treat each teacher fairly and consider each of them in the same way. T10 says that *"Treating each teacher equally creates a peaceful atmosphere among the teachers and resolves possible quarrels"*. Teachers also show tendency to participate actively in decision making process in their schools. T14 advises that *"A fair manager should organize meetings before making a decision and ask for our ideas. Teachers must be the active decider of implementations in our school."* Lastly, teachers think that their managers should undergo management training to ensure a fair decision making process. T16 advises that *"A few of our colleagues have finished master education in educational administration but in fact the managers should actively participate in such kind of an educational process to learn the scientific aspects of management and carry their management tasks out more fairly"*.

#### 4. Conclusion

In this study, teachers' perceptions of justice as both a human being and a teacher and their perceptions of justice in their school management system in terms of decision making process have been revealed. As it can be concluded from the findings, teachers are not satisfied about the distributive decisions taken related to resources in the school and the criteria directing these decisions. They also act in an unfairly affected manner about their managers' interaction styles for informing the decisions.

Each organization's goal should be improving the quality of its decisions. Effects and sense of satisfaction provided by decisions on the lower levels are the most important keys for organizational success. Effective decision-making process, which can be seen as an investment on achieving organization's aims, provides the most vital returns more important than other things. In connection with this point, Greenberg (1990) indicated that "impartiality of the decision-making process, trusting those who have authority to make decisions and relationship system's being based on the idea of respect and trust.

According to Akyuz et al. (2013), managers generally perceive the concept of organizational justice as "justice in the distribution of authority, status, awards and resources in organization". In addition, distribution justice in public organizations is not adequately taken into consideration; the respect and courtesy rules in the communication between the employees are paid more attention in the upper levels than in the lower levels; it is understood that employees participate in decisions but are not effective when the final decision is made and the in-organizational corrective justice mechanisms do not function functionally.

Decision – making consists of mental, physical and emotional processes related to making choices between various purposes, their ways, means and possibilities. Decision – making is described as a stressful process because of its troublesome feature. It's a difficult and stressful job to find alternatives and to find and compare their cons and pros. Decision – making is meant to surpass the problems and obstacles to reach the goals. So, decision – making is struggling with problems and uncertainties and by ignoring them and knowing how, when and how to do things. In this respect, participation in the decision – making process has a critical role in the embodiment of procedural justice perception. Studies on process control have revealed a positive correlation with organizational justice (Bies & Shapiro, 1987). The fact that managers share the decision-making process is an important factor in achieving organizational justice.

Decision-making is a process, just like management. However, decision-making includes evaluating the conditions in order to choose the direction of the action in alternative situations. While making a decision, all available information should be reviewed to evaluate alternative situations and to create proper decision-making strategies (Gambetti et al., 2008). In this context, the lack of justice in decision-making processes that may arise can withhold the plans of organizations that can be successfully implemented, just like it can block all the processes that need to exist (Polat & Celep, 2008).

Organizational decisions are the choices which the managers create to overcome the difficulties they face in their positions. The aim of this process which must be accepted by all steps of the organization is to reach organizational purposes (Mescon, 1988). That's why, decision – making process which is a vital part of management process has a direct relationship with the perception of organizational justice. How decisions are taken on the income of employees within the organization, which criteria is operated by the management while reaching these decisions, the decisions which the decision – makers make with the employees are the most important factors that determine to what extent the perception of justice in the organization will continue (Arslan and Rata, 2015).

Increasing competition environment has directed organizations to the best, perfect and the most successful and thus, organizations have been in the research together with that. This seeking is the effort of both developing the employees and making the organization become sufficient itself. The most critical element forming organizations is human. The most significant expectation towards the employees is their self-motivation and displaying high performance. Today, the concepts of organizational justice and motivation are highly important for all the institutions and organizations.

## Teachers' Perception of Justice in Decision Making Process

Because these concepts are two concepts that complete each other although they may seem to be two separate factors. In order to provide motivation in employees, perception of organizational justice should be formed. When motivation perception is provided, performance and efficiency is provided, too. Such concepts as organizational justice, organizational commitment, job satisfaction, organizational citizenship and motivation are connected to each other just like the rings of a chain. Even a little defection in one of these rings damages the others. The fundamental aim of establishing the organizations is to make profit and gain satisfaction. When the concept of satisfaction is provided reciprocally for both the organizations and employees, achievement is made to a large extent. The fact that organizations have higher expectations from their employees, that they display a perfectionist and meticulous attitude, and the backbreaking conditions of work life causes the employees to have a prejudiced point of view. This view harms the organizational justice perceptions of the employees and negatively affects their motivation levels. Administrators and leaders have significant part at this point. Directing the perceptions in a positive way, providing motivation, increasing the performance and efficiency are among the duties of a successful leader or administrator. In our country, health is a dynamic sector. As it is open to continuous change and improvement, the employees have been made to be dynamic, too. To be able to continue its existence depends on its employees and the organizations that are obliged to manage them in the best way. The employees of health sector, in which there is immense sacrifice both individually and organizationally, face difficulties not only in professional life but also in private life. It is impossible for the employees to work with high motivation, patience and tolerance at every moment of the day. That's why, when the topic is taken into consideration from both aspects, the point of views of the employees towards organizational justice and their job motivations display how difficult and troublesome process is to manage an organization.

In providing organizational commitment, the perception of whether the employees are fairly treated within the organization has a significant role. Within this framework, this research will shed light on the researches done later on from the point that it puts forth the perceptions of how fairly the employees are treated within the organization and the effects of these perceptions on commitment. As organizational justice is the fairly perception of the share and outcomes that the individual reaches and gathers, organizational commitment of the employees will decrease when that share is not fair, together with such problems as a decrease in performance and efficiency, a loss of motivation, developing negative attitude towards the organization, and not making extra effort for the fulfillment of organizational aims and objectives.

Employees with positive organizational justice perceptions become more successful, efficient and happier in organizations, show a high and qualified performance and feel confidence in the organization and the administrator. On the other hand, employees with negative organizational justice perceptions display low performance, lack attendance and become alienated from the organization. That's why, organizational justice and its dimensions are significant for both the employees' job satisfaction and motivation, and the organization's achievement. The most important factor that increases motivation is fulfillment of the employees' desires and their expectations from the organization. The expectations of the employees can be expressed as; fairly distribution of the deserved gains among all the employees of the organization, fairly application of decision making processes while making organizational decisions about distribution and objective transmission of these decisions to the employees.

So as to reach the objectives in an organization, the point to be set out from should be organizational justice. Setting out by perceiving organizational justice in the organization helps to get action by understanding where the problem or deficiency is. The most important factor for providing or changing organizational justice is the attitude of top management and directing necessary actions to set organizational justice, and it is very critical to embrace this process. In order to decrease anti-social behaviors towards organizational justice, top management must detect these anti-social behaviors and must take the necessary precautions to be able to prevent these behaviors. For the decisions aiming to increase organizational justice, getting the views and advices of the individuals that top management is in charge of will make the individual concede the decision even it affects the individual negatively. The more the employees are included in these works within the process, the

faster and the more efficient their organizational embracement will be. The borders of the prizes and punishments that will be given by the organization should be defined and these rules should be informed to the employees. After the desired organizational justice perceptions are embraced by the employees, educational seminars should be organized periodically, by taking into consideration the ratio of labor force motion, related to behaviors displayed and supposed to be displayed so as to provide organizational justice. Top management must lead to all these processes.

Competences suitable for the rules to provide organizational justice in the organization must be defined and the interviews must be done accordingly. In the organizations where there are employees having such competences as personal integrity and honesty, ability and team work spirit, the probability of encountering anti-social behaviors will be extremely low. So long as the employees in the organization, just like the research findings also defined, are supported by educational activities, the possibility that they display stress behaviors related to their work will be fairly low.

One of the main duties of the administrators is to provide the attitudes of the employees towards the administrator and the organization to be shaped in a positive manner. Organizational justice perception is seen to be a significant tool to accomplish this task. Within this context, if the employees perceive that they have impact on the decisions made on the subjects related to themselves and they have equal opportunities to reach the administrator, organizational justice perceptions within the organization will be empowered. Empowering justice within the organization will improve the employees' organizational commitment and their trust through the system. Displaying fair attitudes and behaviors by the administrators will provide a positive organizational justice perception on the employees and in the long term, it will make the solidarity among the employees improve. The employees judge the attitudes and behaviors of the administrators and other employees towards themselves as an indicator of organizational justice. Moreover, ethical and fair behaviors displayed by the authority of the organization minimize the problems about work and organization by decreasing the personal anxieties of the employees about unjust treatment.

## 5. References

- Akyuz, U., Demirkasimoglu, N. & Erdogan, C. (2013). Milli Egitim Bakanligi Merkez Orgutundeki Yoneticilerin Orgutsel Adalet Algilari [Organizational Justice Perceptions of Administrators in Central Organization of Ministry of National Education]. *Education and Science*, 2013, 38(167), 273-288.
- Arslan, H. (2018). *An Introduction to Education*. London: Cambridge Scholars Publications.
- Arslan, H. and Rata, G. (2015). *Interdisciplinary Perspectives on Social Science*. London: Cambridge Scholars Publishing.
- Aydin, M. (2010). *Egitim Yonetimi* [Educational Management] (9. Baski). Ankara: Hatiboglu.
- Bakan, I. and Buyukbese, T. (2004). Orgutsel iletisim ile is tatmini unsurlari arasindaki iliskiler: Akademik orgutler icin bir alan arastirmasi [Relationship between organizational communication and job satisfaction: A case study for academical field]. *Akdeniz I.I.B.F. Dergisi [Journal of Akdeniz Faculty of Economics and Administrative Sciences]*, 7, 1-30.
- Besler, S. (2009). Karar verme surecinin etkinligi ve stratejik uzlasi [The effectiveness of decision making process and strategical agreement]. *Amme Idaresi Dergisi [The Journal Public Administration]*, 42(2), 89-108.
- Bies, R. J. & Shapiro, D. L. (1987). Interactional fairness judgements: The influence of casual accounts. *Social Justice Research*, 1, 199-218.
- Blau, P. (1964). *Exchange and power in social life*. New York: Wiley.
- Colquitt, J. A.; Greenberg, J. and Zapala-Phelan, C. P. (2005). *What is organizational justice*. Mahway: Lawrence Erlbaum Associates.
- Drucker, P. F. (2001). Effective decision. *Harward Business Review on Decision Making*, Harward Pres, 1-21.

## Teachers' Perception of Justice in Decision Making Process

- Gambetti, E.; Marco, F.; Luca, B. & Lorenzo, T. (2008). A Contribution to the Italian Validation of the General Decision-Making Style Inventory, *Personality and Individual Differences*, Vol: 44, No: 4, 842 – 85.
- Greenberg J. (1990). Organizational Justice: Yesterday, Today and Tomorrow, *Journal of Management*, Vol: 16, Sayı: 2, 399- 432.
- Greenberg, J. & Lind, E.A. ( 2000). The pursuit of organizational justice: From conceptualization to implication to application. In C. L. Cooper & E. A. Locke (Eds.), *I/O psychology: What we know about theory and practice* (pp. 72-105). Oxford , UK: Blackwell.
- Hoy, W. K. & Miskel, C. G. (2010). *Eğitim yönetimi teori, araştırma ve uygulama* [Educational management theory, research and practice.]. (Cev. S. Turan). Ankara: Nobel.
- Hoy, W. K. & Tarter, C. J. (1995). *Administrators solving the problems of practice: Decision-making concepts, cases, and consequences*. Massachusetts: Allyn and Bacon.
- Hubbell, A. P. & Chory, R. M. (2008). Organizational Justice and Managerial Trust as Predictors of Antisocial Employee Responses. *Communication Quarterly*, 56(4), 357–375.
- Kaya, Y. K. (1996). *Eğitim Yönetimi Kuram ve Türkiye'deki Uygulama* [Education Management Theory and Practice in Turkey]. Ankara: Bilim.
- Mescon, M. H., Albert, M. and Khedouri, F. (1988). *Management*. New York: Harper & Row Press.
- Moorman, R.H. (1991). Relationship Between Organizational Justice and Organizational Citizenship Behavior: Do Fairness Perceptions Influence Employee Citizenship? *Journal of Applied Psychology*, 76, 845-855.
- Polat, S. & Celep, C. (2008). Perceptions of secondary school teachers on organizational justice, organizational trust, organizational citizenship behaviors, *Educational Administration: Theory and Practice Spring*, 54, 307-331.
- Yıldırım, A. & Simsek, H. (2006). *Sosyal Bilimlerde Nitel Araştırma Yöntemleri (Qualitative Research Methods in Social Sciences)*. Ankara: Seckin Yayıncılık.





# The Management of Conflicts among Teams in the School and the Leader's Impact on the Conflict Process

Ismail Erol, Ismail Karsantik

## 1. Introduction

When looking at the dictionary of the Turkish Language Institution, the words; disagreement, confrontation, conflict and antagoism seems as war (TDK, 2015). In **the** language used in current and academic studies in terms of English, the word "conflict" is not exactly named in Turkish language. Conflict has been seen to be counteracted in the form of conflict, contradiction, disagreement, friction, controversy (Gumuseli, 1994). Forced conflicts are of an opposite meaning with negative expressions which overturns the balances that the employee creates in the institutional environment during conflicts, and force the employee to balance again (Basaran, 1991). The first meaning that the concept of conflict generally refers to negativities such as fighting, war, fighting in organizations. For this reason, extraordinary efforts are being made to ensure that the feelings of unity and solidarity between the individuals and the organizations are dominant in the societies. However, conflict is constantly present both in society and in nature. Conflict should not be mentioned with always negative expressions in organizations. If conflicts are well organized and managed within the organization, the quality of the organization may increase (Fleetwood, 1987, p.6).

Organizational conflict is the confusion that arises as the result of perceiving and reaching the targets of the individual as an obstruction of others (Robbins, 2005, p.422). Since education organizations are a small model of society, conflict is also present in these organizations. Moreover, the conflict in education organizations which have human beings in its input, in process and in its output is more concrete and real. Therefore, we should not learn to escape uninvolvedly, but to learn the methods and techniques of managing it, realizing that there are conflicts in organizations and in society in some extent also in nature (Sarpkaya, 2002). Zembat (2012) stated that conflicts in education organizations are inevitable. Since forces and groups are more fluent in the school environment, even unimportant friction can be transformed into unexpected conflict situations (Bursalioglu, 2008, p.157). While teachers, students, civil servants, and other staff are defined as internal components of the school; the stakeholders such as the leaders of these groups, the management structure and the business organizations are defined as external components constituting the school (Bursalioglu, 2008, p.39).

Relations between the school staff and the school's external environment (family, etc.), as well as administrator-teacher and teacher-teacher relationships, are factors that affect the educational quality of schools (Cinkir and Cetin, 2010). These relationships are likely to involve conflict. Conflict management within the context of organizational culture requires effective leadership. In any case, leadership affects, directs and controls the activity of a person or group in order to achieve the goal, while at the same time ensuring the group by bringing the group members together (Tevruz et al., 1999: 189, Bennis and Nanus, 1985). Many factors, such as organizational characteristics, priorities, organizational culture, the characteristics of the individuals forming the organization, affect and diversify the leadership style in achieving the goals of the organization (Ozmen and Akuzum, 2010). It is important for organizational leaders to be knowledgeable and competent about effective conflict management strategies to manage the conflict effectively and effectively. Rahim (1992) developed conflict management styles based on conflict management styles developed by Blake and Mouton. According to the dedication of the persons to meet their interests or the interests of others Rahim (1992, pp. 23-25) set a model which is classified as; integration (where the interests of both sides of the conflict are protected), avoidance (conflict is ignored), reconciliation (conflicting parties have met in

the middle way at a certain rate), concessions (one of the crossing parties has given up in favor of the other) and domination (resulted in the loss of one side and the acquisition of the other side).

The aim of this research is to examine conflict situations between teams in Turkey and determine the effect of school leaders on these conflict processes. Despite the fact that teachers, administrators and educational leaders are among the most strategic parts of schools (Bursalioglu, 2008, p. 42) it is seen that there is limited research on conflict situations that they have experienced as one of the parties to the school and the solutions they have proposed regarding these situations. It is important to know the conflict situations experienced by the leaders in these institutions and the solutions they use in these conflict situations, especially in terms of educational quality, as conflict situations in educational institutions can affect the work productivity of employees as they are in other institutions. All this information reveals that conflicts are effective in realizing the aims of organizations. Therefore, in this research it is aimed to determine the conflict situations of the leaders and the solutions they have applied in these situations.

## 2. Data Collection and Data Analysis

Content analysis method was used in this study in which research (articles and theses) on conflict management applied in schools in Turkey were examined through content analysis. Content analysis, which is often used in the social sciences and qualitative research, is a systematic, repeatable technique in which certain words of a text are summarized with smaller content categories with certain rules-based coding (Buyukozturk et al., 2013). The basic process of content analysis is to bring together similar data within the framework of specific concepts and themes and to interpret them in a way that the reader can understand. (Yildirim and Simsek, 2011, p 227). Content analysis is a method that helps to evaluate literature in a specific field (Falkingham and Reeves, 1998).

Twenty (20) articles on "conflict management", "conflict management in schools" and "conflict management in educational organizations" in the field of educational sciences in Turkey and ten (10) postgraduate theses on "conflict management" covering 2010 and later constitute the focus of this study. Since leaders are concerned with conflict management, these articles and theses have been examined. In Turkey, especially in the field of educational sciences, education management and supervision, it has been concentrated on the last 10 years since it has been working rapidly in the last 10 years. The information about the selected studies are demonstrated in Table 1.

**Table 1. Selected Studies**

Years	Number of Articles	Masters Degree	Doctorate Degree
2010	2	1	
2011	3	-	1
2012	2	-	
2013	4	3	1
2014	4	1	1
2015	3	2	
2016	1		
2017	1		
<b>Total</b>	<b>20</b>	<b>7</b>	<b>3</b>

In this study, expert opinion was obtained from 1 professor, 2 assistant professors and 1 research assistant who have already conducted studies on conflict management. The opinions of these experts have been taken in determining the scope of years for the validity of the work. 25% of the experts, believe that it is needed to examine academic studies in 2005 and later while 75% of them think that academic studies in 2010 and later are needed to examine. The title restriction on the collection of data

within the scope of the study has also been made by taking expert opinions. 50% of the experts stated that "conflict management", 25% "conflict management in schools" and 25% "conflict management in educational organizations" would make the data of the study more sound and accurate.

In this study, twenty (20) articles covering "conflict management", "conflict management in schools" and "conflict management in educational organizations" published in academic journals and 10 postgraduate dissertations reached from the National Thesis Center were classified and analyzed under eight (8) headings. When analyzing, each article and dissertation is carefully examined and classified according to the topics, years and leaders' conflict resolution methods. When these stages are implemented, especially in some articles it has been observed that there is not enough descriptive information about subject, content, method, data collection tools and data analysis methods. After this situation is discussed among the researchers, a common idea is reached and the data is coded accordingly.

### 3. Findings

#### 3.1. Conflict Management Strategies

As a result of analyzing the data; it is found out that Rahim (2000) considered the conflict as a positive process for the organization and set out the following conflict management strategies for leaders:

- Integration
- Compromise
- Establishing dominance
- Avoidance
- Compromise

The appropriateness of conflict management strategies varies according to the situation of conflict. Some conflict management processes are appropriate and effective for the conflict process, while others are ineffective. The following are examples of situations in which the use of conflict management strategies by Rahim (2000) is appropriate or not:

**3.1.1. Integration:** One of the effective solutions that can be used to solve complex problems. It is a suitable strategy for the problems that need more knowledge and skills of different people to resolve. It is not appropriate to use this strategy when it is necessary to resolve the emerging problem urgently and where there are simple and insignificant problems.

**3.1.2. Compromise:** It is a strategy that is appropriate in situations where the person himself regards it as unfair, that it is more important in terms of the other side, where the person is in a weak position and the protection of relations is important. It is a solution strategy that is important for the individual and is not appropriate for situations where the person feels right or the other side is unethical.

**3.1.3. Domination:** It is appropriate to use it in situations where it is necessary to make quick decisions and in trivial situations while it is not appropriate to use in situations which are complex, insignificant, and both sides are equally powerful.

**3.1.4. Avoidance:** It is appropriate for simple and time-consuming tasks; yet it is not an appropriate strategy for situations where decision-making responsibility is on one person, matters that are important, and situations that require quick decision-making.

**3.1.5. Reconciliation:** The use of this strategy is appropriate if the issue is specific for both sides, the parties are of equal strength, an agreement can not be reached, domination and integration do not work. However, it is not a suitable strategy when one of the parties is strong.

### 3.2. Team-to-Team Conflicts on Schools

When analyzing the data, it is indicated that there are some teams (teachers, school administrators, parents, service workers, students, health workers, etc.) in schools. From time to time, there is a conflict between these teams and leaders need to manage these conflicts in the best way for the benefit of the institution.

The following conflict situations lead to the frequent conflicts in schools:

1. Teacher-teacher conflicts
2. Teacher-parent conflicts
3. Conflicts between teacher and school administrators
4. Conflicts between teacher and health care workers
5. Teacher-servant conflicts
6. Teacher-student conflicts
7. School administration-parent conflicts
8. School administration student conflicts
9. School administration-servant conflicts

**3.2.1. Teacher-teacher conflicts:** In schools, it is at the top of the most common conflict situations. Teachers can be teams even according to their clan, class, branch, gender, age, floor, even neighborhood ties. Another teacher may be in conflict with the team. This process can often make educational situations difficult. A qualified training leader must intervene.

**3.2.2. Teacher-parent conflicts:** Some teachers act together against various parents' teams. It is often found in schools, especially with school-family units. Increasing demands of the parents, over-followers of their students and their desire to supervise the teacher are pushing the teachers to be a team against the parents. In order for the school and its students not to be affected, a training leader is a must for the process.

**3.2.3. Conflicts between teacher and school administrators:** Teachers can organize and form teams with attitudes towards overpowering school administrations. This situation can be seen in two teams of teachers that are close to school management and not. Teacher attitudes that the administration dislikes or does not approve of, cause this conflict situation. This is the result of administration that can not manage the conflict process.

**3.2.4. Teacher - healthcare workers conflicts:** Especially in private education institutions and pre-school education institutions, it is a conflict situation experienced by healthcare workers. The fact that healthcare workers do not perform their duties, the efforts of teachers and healthcare workers to manage each other and faults in speaking and making a job done lead to this conflict situation. In this conflict, the mediator role of the education leader is also important.

**3.2.5. Teacher-servant conflicts:** Especially after the employment of part-time and contracted personnel by ISKUR (Turkish Employment Agency) in the schools, there has been a conflict between school staff and school teachers. It constitutes the basis for conflict situations in which no work is undertaken, forced labor, job interruption and not doing the job properly. In this case responsibility lies with school leaders and administrators.

**3.2.6. Teacher-student conflicts:** It is one of the conflicts that are often encountered at schools. The overwhelming attitudes of the teachers, frequent and intense assignments, authoritarian behavior, disrespectful and irrational behavior of students are the main elements of these conflicts. In these conflict situations, it may not be possible to benefit from educational opportunities. Conflicts must be resolved with a good strategy and method.

**3.2.7. School administration-parent conflicts:** It is a conflict that is carried to a higher level as a result of teacher-student, teacher-parent conflicts at schools. Apart from these processes, the parents who cannot get the benefit from the school or who are not satisfied with the school administrators may also be a conflict element. In the same way, the fact that the school administration can not meet the expectations of the parents is also the basis of this conflict.

**3.2.8. School administration-student conflicts:** School administrations are often not in close contact with students. In fact, administrators of institutions based on student need to pay more attention to their students and take their needs into account. The most important factor that triggers this conflict situation is social and cultural expectations of students and school activities. A good education leader should manage these processes well.

**3.2.9. School administration-servant conflicts:** These conflicts are arising from the school administrators' passive attitudes, their inability to speak to their servants, and their idle servant attitudes. School management is also the basis for these conflict situations. If the staff cannot be managed well, it is likely that there will be conflict situations. Teacher-servant conflicts are also triggering this conflict.

### 3.3. Types and Levels of Conflict in Schools

When analyzing the research data, it is seen that the most common conflict type in schools is "cultural", followed by "ideological" and "conflicts of interest". Individual cultural differences and social activities include school culture conflicts that are created by school rules such as course entry, course schedules and school vigilance. Some of the research data suggested that there were moderate conflicts in their schools (15 studies), that there were low levels of conflict in 8 studies and a high level of conflict in 7 studies. In fact, the literature of the field also points to the necessity of moderate conflicts in terms of ensuring development and change in organizations.

It is seen that the causes of conflict in schools are mostly "cultural and ideological".

Other reasons are;

- Gossip,
- Environmental factors,
- Socio-economic situation
- It is seen that there are other reasons given in descending order.

### 3.4. School Leaders and Conflict Situations

When examining the conflict situations arising from school leaders, 16 studies conclude that conflicts originate from school leaders, and 14 studies put forward that conflicts originate from other reasons. The management style of the school leader leads to the "school culture" and "school management-staff" conflicts. It is also seen that this situation causes the conflicts of "teacher-teacher", "teacher-student", "teacher-guardian" and "interest" to occur. It appears that there are also school administrators who are "positive" (fair, constructive, restorative, corrective), "analytical", but in a "reactive" and "avoidant" attitude to conflict.

### 3.5. School Leaders' Attitudes Towards Teams

School administrators are most likely to be in a "positive (listening, constructive)" attitude to the conflicting parties, while attitudes including official procedures such as "legislator", "negative (punitive, harsh, stimulating)", "neutral" are also exhibited. The elements that determine school administrators' conflict management style are "desire for continuous learning for learning-teaching purposes, professional development, collecting information, analyzing conflict situations, sharing the solutions, participating in the decision making" and "gaining experience and sharing it". It is also important to develop and cultivate school cultures, to ensure cultural integration, to strengthen communication, and to ensure compliance with school rules. It is also important for school administrators to determine the manner of conflict management (situational leadership) according to

the elements of conflicting sides (conflict initiation, maintenance or termination, prejudice, obeying school rules) and subject of conflict (school culture, personal issues, environmental factors). Considering the suggestions of school administrators on conflict management to ensure that conflicts contribute positively to school culture, administrators emphasize the importance of analyzing and synthesizing conflicts primarily and emphasize the importance of keeping people's morale high and the necessity of implementing the legislation in order to fairly deal with conflicting parties, to establish empathy and to end conflict.

### 3.6. Leaders' Conflict Solutions Between Teams

According to the findings of the studies; school leaders often use "integration and reconciliation" styles to resolve conflicts, while "concession" and "avoiding" styles are occasionally used and "dominant" styles are used less frequently. In the study conducted by Ozmen (1997), it was concluded that the administrators used the "ruling" style to a lesser extent. In another study (Niederauer, 2006), it was understood that senior administrators at universities used integration styles first, compromise secondly, compromise and domination thirdly, and avoidance conflict styles in the last place to solve conflicts. Similarly, in Ural's (1997) doctoral dissertation, "Methods of Directing Conflicts between Primary School Administrators and Teachers", methods used in managing conflicts between administrators and teachers in primary schools are found as problem solving, compromise, avoidance and domination. In a study conducted by Gumuseli (1994), it was observed that school administrators used the style of integration in managing conflicts with teachers, followed by compromise, compromise, avoidance and domination styles respectively.

### 3.7. Leaders' Conflict Management Choices

Three basic questions need to be answered in determining which style of conflict management is appropriate and which style should be preferred (Karip, 2003, p. 69):

- a) Which conflict management style will contribute more to organizational effectiveness?
- b) Which conflict management style will contribute more to satisfying social needs?
- c) Which conflict management style will contribute more to meeting the ethical and moral needs of the members of the organization?

### 3.8. Conflict Management Ways of Leaders

**3.8.1. "Keeping Busy" Method:** The administrator who applies this way tries to keep conflicting parties busy by giving more jobs. Organizations with too much workload may not have time for conflict, as they will give their energy and time to their jobs. This path will reduce the conflict but will not remove it. The conflict is brought to a temporary solution (Eren, 1991, p. 443).

**3.8.2. Changing Contacts:** When conflict occurs, administrators try to solve the conflict by assigning persons who are parties to the conflict to other units or by assigning them to other places. This way, however, should be used when conflicts occur which cause harm (Genc, 2004, p.260).

**3.8.3. Drawing Method:** This method may be preferred if the conflicting parties or groups are deemed to be justified and the consent of the person or groups is required. The losing side in the result of the draw has to accept the result. But on the losing side; morale, motivation, and organizational commitment may decrease and may lead to more severe conflicts in the coming days. Frequent use of this method can cause profound internal injuries within the organization. (Can, 2005, pp. 385).

**3.8.4. Referee Application:** Conflicting parties can be referred to this way when they can not find a solution to the problem they are experiencing in conflict, and when they are not satisfied with the solution offered to them. In this case, a third person or group, which has earned the respect and trust

of both parties, is referred to. The referee makes the decision after hearing the views of both parties. (Eren, 1991, pp. 441).

**3.8.5. Identification of Common Goals:** Using this method, the administrator identifies common goals for conflicting groups or individuals and may enable them to collaborate on specific issues. These goals must be at the level that a single group or person can not succeed. Thus, these groups or individuals will need the help and cooperation of other groups or individuals (Can, 2005, pp. 384). For example, in a school, English and German teachers with conflicts can be assigned to prepare an EU project.

**3.8.6. Changing Organizational Relationships:** Administrators who use this method try to reduce organizational conflict by reorganizing organizational relationships or by developing existing relationships (Genc, 2004, p. 260).

**3.8.7. Finding New Possibilities:** Scarce sources are at the most common cause of conflict. The aim of this method is to find conflict solutions by increasing scarce material and human resources in organizations. In this way, the financing opportunities of the organizations can be increased, the number of jobs can be attracted to a sufficient level, the needs such as machinery and goods necessary for the organization can be met. With the creation of new resources, departments and people will have less conflict with each other (Eren, 1991, p. 443).

### **Discussion and Conclusion**

For school leaders to manage conflicts in the best way, it is important to understand the nature of the conflict and to identify the factors that influence the administrators' conflict management style preferences. In this study, conflict situations, conflict management styles used by school administrators in resolving conflicts were examined, and conflict management style preferences of school administrators were investigated. The results obtained are as follows:

The data reveal that school administrators always use the integration style. According to this, it can be stated that the administrators of schools are meeting with the parties of the conflict in the event of a conflict, continuing to negotiate until a solution satisfying all the parties is found, and making all parties of the conflict a part of the solution. The style of conflict management style that our administrators use frequently in our schools is style of integration. Secondary conflict management style is compromise. Research data show that school administrators use the style of integration often, occasionally use compromise style and rarely use avoidance styles. This result shows that school administrators only choose to escape without conflict when they are in very difficult situations or to make concessions for a solution. The conflict management style, which is used least by the school administrators participating in the research when resolving conflicts, is the style of domination. The domination style requires that the administrators use his power and authority to resolve conflicts. School administrators' conflict management style preferences also overlap with other research results. Previous studies have found that school administrators use the most integration style and then use consensus, compromise, avoidance, and governance styles, respectively (Oguz, 2007, p.54). As an organization, each school administrators who makes up a school has different backgrounds, values, truths, philosophical insights and cultures. There are occasional conflicts in the schools as indicated in the studies examined. In this sense, it is inevitable that there will be some disagreements in every school environment by starting from the thought of "There is always a problem in where the person is". What is important here is to be able to direct these conflict situations to the benefit of the school within the framework of the school's common goals.

### **Situations in which teachers conflict with administrators:**

- a) The fact that the administrators ask the teachers to prepare and present the activities that are attended by all the children in the ceremonies,



- b) The fact that the administrators are insensitive to the physical conditions of the material and classroom, such as auxiliary staff,
- c) The use of dues from children to cover the cost of the class is under administrative control and these dues are used to address other school needs,
- d) The lack of information on preschool education by administrators and parents,
- e) The administrators are not equal to the teachers.

**The conflicts that teachers have with their colleagues:**

- a) The co-operation of teachers from different disciplines and levels of education,
- b) Lack of information sharing,
- c) The fact that half-day institutions must use the same classroom,
- d) Competition and burnout,
- e) Not being able to act jointly and grouping among teachers.

**The conflict situations in which teachers live with their parents:**

- a) The lack of information about the importance of pre-school education,
- b) Teacher distrust,
- c) Intervention to the subjects that fall within the authority of the teacher,
- d) Not considering the school's program hours
- e) Perception of teacher as a carer instead of an educator.

When the results of the research are evaluated, it can not be stated that there is a healthy communication between school administrators, teachers and the environment. By acting in this interpretation, it can be suggested that school administrators will be able to negotiate existing problems together and produce alternative solutions in cooperation, if more negotiations can be made with the parties in conflict. Opportunities may be drawn up by meeting with the school administrator, the teacher, and the school community frequently. In order to effectively manage the types of conflicts that arise in educational organizations, it is necessary to know the sources of the conflicts very well. For this reason, research should concentrate on finding out sources of conflict at schools. For school administrators (whether experienced or new school head), in-service training activities related to conflict management should be organized. People in school management must accept that conflict is natural. For the resolution of conflicts, school administrators must use more than one method, sometimes at the same time and sometimes with the order.

**5. References**

- Basaran, I. E. (1991). *Orgutsel davranis. Insanin uretim gucu*. Ankara: Ekinoks Yay.
- Bursalioglu, Z. (2008). *Okul yonetiminde yeni yapi ve davranis*. (14. baski). Ankara: Pegem Akademi Yayinlari.
- Buyukozturk, S., Kilic Cakmak, E., Akgun, O. A., Karadeniz, S. ve Demirel, F. (2013). *Bilimsel arastirma yontemleri*. Ankara: Pegem Akademi Yayıncılık.
- Can, H. (2005). *Organizasyon ve yonetim* (7. baski). Ankara: Siyasal Kitabevi.
- Cinkir, S., & Cetin, S. K. (2010). Ogretmenlerin okullarda mesleki calisma iliskileri hakkındaki gorusleri. *Educational Administration: Theory and Practice*, 16(3), 351-376.
- Eren, E. (1991). *Yonetim ve organizasyon*. Istanbul: IU Isletme Fakultesi Yayinlari.
- Falkingham, L. T., & Reeves, R. (1998). Context analysis a technique for analysing research in a field, applied to literature on the management of R & D at the section level. *Scientometrics*, 42(2), 97-120.
- Fleetwood, K. L., (1987). *The conflict management styles and strategies of educational managers* (Unpublished doctoral dissertation). University of Delaware, Newark.
- Genc, N. (2004). *Yonetim ve organizasyon: Cagdas sistemler ve yaklasimlar*. Ankara: Seckin Yayınevi.
- Gumuseli A. I. (1994). *Izmir ortaogretim okullari yoneticilerinin ogretmenler ile aralarındaki catismalari yonetme bicimleri*. (Yayınlanmamis Doktora Tezi). Ankara: A.U. Sosyal Bilimler Enstitusu.

- Gumuseli, A. I. (1994). *Izmir Ortaogretim Okullari Yoneticilerinin Ogretmenler Ile Aralarindaki Catisma Yonetme Bicimleri*. Yayinlanmamis Doktora Tezi. Ankara Universitesi Sosyal Bilimler Enstitusu, Ankara.
- Karip, E. (2003). *Catisma yonetimi*. Ankara: Pegem A Yayıncılık.
- Oguz, Y. (2007). *Okul mudurlerinin demografik degiskenler ve kisilik ozellikleri ile catisma yonetimi stili tercihleri arasindaki farkliliklar ve iliskiler*. (Yayımlanmamis yuksek lisans tezi). Yildiz Teknik Universitesi Sosyal Bilimler Enstitusu, Istanbul.
- Ozmen, F. (1997). *Firat ve Inonu Universitelerinde orgutsel catismalar ve catisma yonetimi yaklasimlari*. (Yayımlanmamis doktora tezi). Firat Universitesi Sosyal Bilimler Enstitusu, Elazig.
- Ozmen, F., & Akuzum, C. (2010). Okullarin kulturel yapisi icinde catismalara bakis acisi ve catisma cozumunde okul yoneticilerinin liderlik davranislari. *Sosyal ve Beseri Bilimler Dergisi*, 2(2), 65-75.
- Rahim, M. A. (2000). *Managing conflict in organizations*, Westport, USA: Greenwood Press. Retrieved from <http://site.ebrary.com.onelog.marmara.edu.tr>.
- Robbins, S. P. (2005). *Organizational behavior*. New Jersey: Pearson Prentice Hall.
- Sarpkaya, R. (2002). Egitim orgutlerinde catisma yonetimi ve bir ornek olay. *Kuram ve Uygulamada Egitim Yonetimi Dergisi*, 8(3), 414-429.
- Turk Dik Kurumu [TDK] .(2015). *Turk dil kurumu sozlugu*. <http://www.tdk.gov.tr/>
- Tevruz, S., Artan, I., & Bozkurt, T. (1999). *Davranislarimizdan secmeler (orgutsel yaklasim)*. Istanbul: Beta Basim yayin Dagitim.
- Ural, A. (1997). *Ilkogretim okulu yoneticilerinin ogretmenlerle aralarindaki catismalari yoneltme yontemleri*. (Yayımlanmamis doktora tezi). Abant Izzet Baysal Universitesi Sosyal Bilimler Enstitusu, Bolu.
- Yildirim, A. ve Simsek, H. (2011). *Sosyal bilimlerde nitel arastirma yontemleri*. Ankara: Seckin Yayıncılık.
- Zembat, R. (2012). Okul oncesi ogretmenlerinin okul yoneticisi, meslekaslari ve aileler baglaminda algiladiklari catisma durumlarinin incelenmesi. *Egitim ve Bilim*, 37(163), 1300-1337.



# An Analysis of Graduate Theses on Elementary Education

Yasemin Abali Ozturk, Cavus Sahin, Mehmet Kaan Demir, Serdar Arcagok

## Introduction

Formal education is mandatory for an individual's cognitive, affective, psychomotor, and social development. It is initially offered at elementary education institutions. The first step following pre-school institutions is an elementary school. A high-quality educational elementary school, its conformity to scientific principles, and its congruence with the developing and changing educational understanding, and its adaptation to the globalized world and the age of informatics are achievable by researching the characteristics of education and teaching processes and of active elementary school teachers. Graduate theses account for a great majority of these research studies. Research fields, obtained results, and proposed problems of this kind of theses serve as "lodestars" for the Ministry of National Education, teacher-training institutions, and academicians conducting scientific studies.

Education is a sine qua non for a society to progress, develop, modernize, and become a community of informatics. The most important component of education is teachers. There is a strong relationship between teachers' qualifications and education's quality. Therefore, teachers' professional competencies, behaviors, values, worldviews, and social tendencies affect behaviors and knowledge repositories of students and societies they live in. Thus, teacher training constitutes the most important and essential element of any educational system to create a new society equipped with desirable behaviors, skills and knowledge (Avsar, 2007). Because qualifications of teachers governing an education process are among the basic determinants of quality and productivity in education, what underlie a high-quality education are highly qualified teachers. To achieve the desired quality in teacher training, qualifications of faculty members and preservice teachers and quality of equipment, administration and education programs should be enhanced (Eristi, 2004).

Among the most important social functions of universities are to conduct scientific research studies, to generate knowledge, and to invent. From this perspective, it can be asserted that graduate education at universities play a critical role particularly in knowledge creation (Karkin, 2011). Analysis of scientific theses on a specific subject matter offers some valuable insights into the depth and prevalence of that particular subject and a broader view of the field (Goktas & Erdem, 2006).

In social sciences, there could be a plethora of studies on a single subject. They are independent of each other and irregularly dispersed in the science archive. It is unknown what these works do and do not include in relation to that subject. Compiling these works is of grave importance to perform a general evaluation on them and to lead the way for new researchers. Hence, studies on some certain subjects in social sciences should be examined and evaluated (Arslan, 2018; Ayaz, Oral, & Soylemez, 2015). This is why the analysis of graduate theses on elementary school teachers accounting for majority of teacher population and affecting the educational quality at elementary schools is important.

Researchers such as Agaoglu, Ceylan, Kesim, Madden, and Altinkurt (2005), Kolac (2008), Oruc and Ulusoy (2008), Aksoy, Sonmez, and Meray (2009), Sonmez, Meray and Kaymakci (2009), Tarman, Acun, and Yuksel (2010), Sahin, Gogebakan Yildiz, and Duman (2011), Bektas and Karadag (2013), Coskun, Dundar, and Parlak (2014), Demir and Ekici (2015), Ayaz, Oral, and Soylemez (2015), Arslan and Rata (2015) and Cifci (2017) are among the researchers who have attempted to analyze the theses on teacher training, reading and writing, life science education, social studies education, special education, school administration, etc. It is a fact that graduate works have been increasingly investigated over the last years. However, works on elementary school education are scarce.

### **Aim**

The primary concern of this study is to reveal the general tendencies of graduate theses on elementary education between 2012 and 2016. The following research questions were produced for the purpose of the study:

1. What is the distribution of the open-access graduate theses between 2012 and 2016 by year?
2. What is the distribution of the graduate theses in the corpus by the gender/title of their authors/supervisors, the number of research problems, the number of results and suggestions?
3. What is the distribution of the graduate theses in the corpus by research focus?
4. What is the distribution of the graduate theses in the corpus by research models/methods, data collection methods/tools, and population/sample group?

### **2. Method**

Since this study describes the distribution of graduate theses on elementary education in Turkey by their sub-goals, it is considered as a descriptive study and follows a screening model.

#### ***Population and Sampling***

The population of the study, as of March 2017, consists of 485 open-access graduate theses written on Elementary Education in Turkey between 2012 and 2016, which are archived in the database of the National Thesis Center of Publication and Documentation Department of the Council of Higher Education. 243 graduate theses were isolated from these 485 theses by stratified sampling to create the corpus for in-depth analyses. To reinforce the representativeness of the sampling, the authors resolved to assign 50% of the population as the present study's corpus. 50% of the graduate theses per each year was calculated by stratified sampling and 243 (50%) of the 485 theses were assigned as the corpus. The theses in the sampling were carried out at 74 different universities.

**Table 1.** Graduate Theses in the Corpus by Year

	2012	2013	2014	2015	2016	Total
<b>Frequency</b>	57	63	52	47	24	<b>243</b>
<b>Percentage</b>	23,5	25,9	21,4	19,3	9,9	<b>100</b>
<b>Cumulative Percentage</b>	23,5	49,4	70,8	90,1	100	

As indicated in Table 1, 63 (25,9%) of the graduate theses were written in 2013. This means that 2013 marks the year when the highest number of theses was carried out in consideration of the corpus. Moreover, it can be concluded from the analysis of the theses that the lowest number of theses was produced in 2016.

#### ***Data Collection and Analysis***

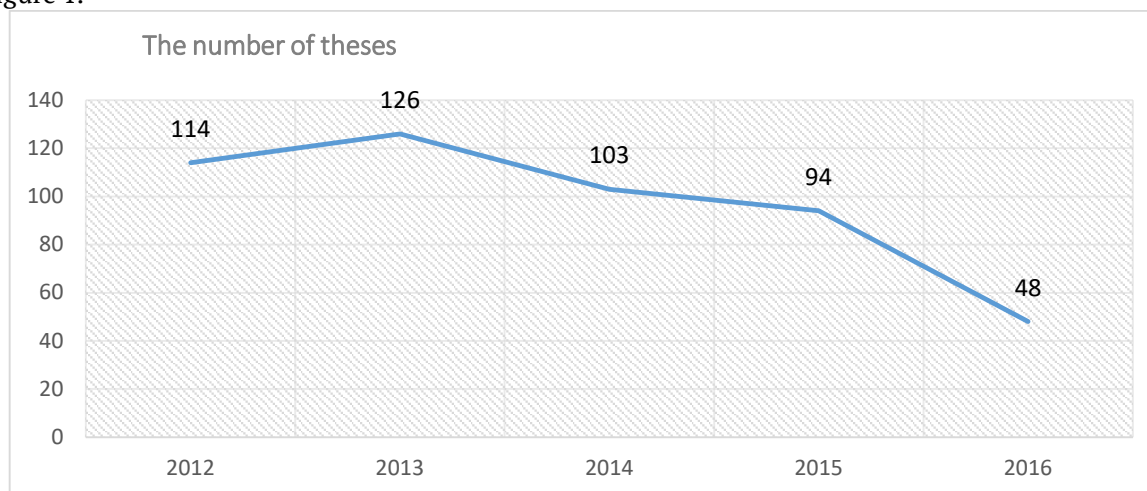
Document analysis was used as the data collection method. Thesis style guides of universities, sets of information in graduate theses, characteristics of scientific research studies and similar studies were reviewed to produce a "thesis analysis form" for the systematic analysis of the theses in the corpus. To ensure validity, the form was delivered to experts and revised based on their feedback. The researchers performed the analyses relying on the thesis analysis form.

The data (gender, title, research model, etc.) which were suitable for statistical analysis were analyzed with SPSS. The remaining data were analyzed by content analysis.

### 3. FINDINGS

#### *Findings on the First Sub-goal*

In view of the first research question “What is the distribution of the open-access graduate theses between 2012 and 2016 by year?”, the distribution of the 485 open-access graduate theses archived by the Publication and Documentation Department of the Council of Higher Education are presented in Figure 1.

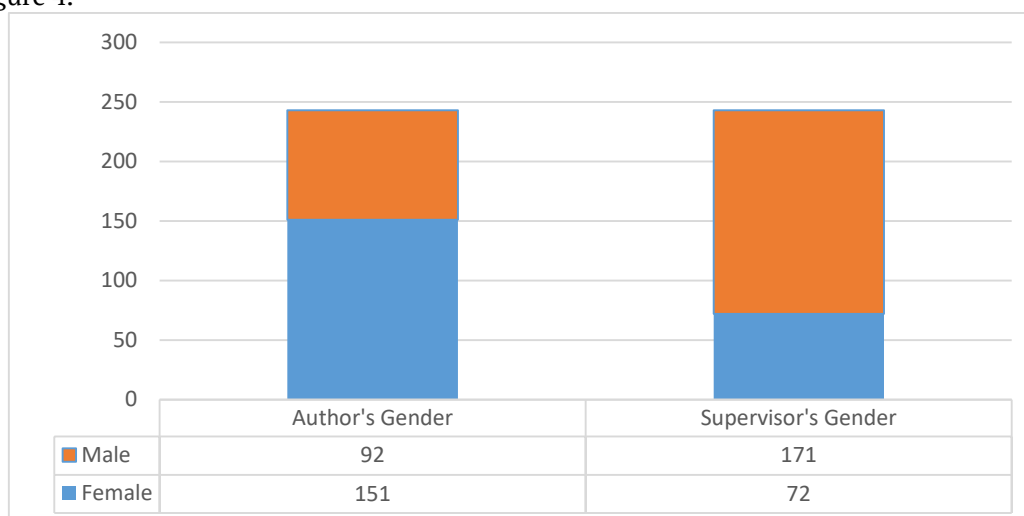


**Figure 1.** Change in the number of graduate theses by year

Figure 1 provides the by-year distribution of the 485 open-access graduate theses between 2012 and 2016, archived by the Publication and Documentation Department of the Council of Higher Education. The fall in 2016 may be misleading because access to the majority of the theses written in 2016 were prohibited by the authors and the number appears to be lower due to the fact that the data collection was conducted by March 2017. The analysis of the fluctuations before 2016 yielded a decline by 23,5% (114) in 2012, by 26% (126) in 2013, by 21% (103) in 2014 and by 19% (94) in 2015.

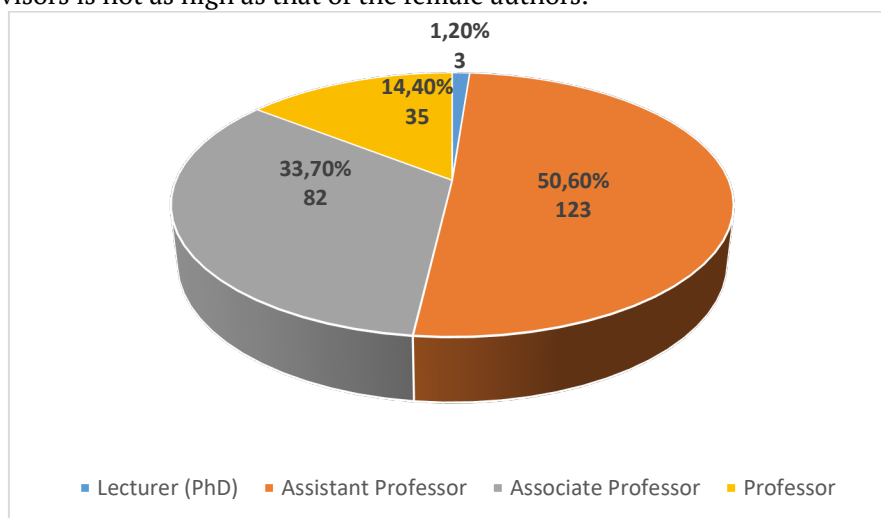
#### *Findings on the Second Sub-goal*

In view of the second research question “What is the distribution of the graduate theses in the corpus by the gender/title of their authors/supervisors, the number of research problems, the number of results and suggestions?”, the distribution of the 243 open-access graduate theses archived by the Publication and Documentation Department of the Council of Higher Education are presented in Figure 2, Figure 3 and Figure 4.



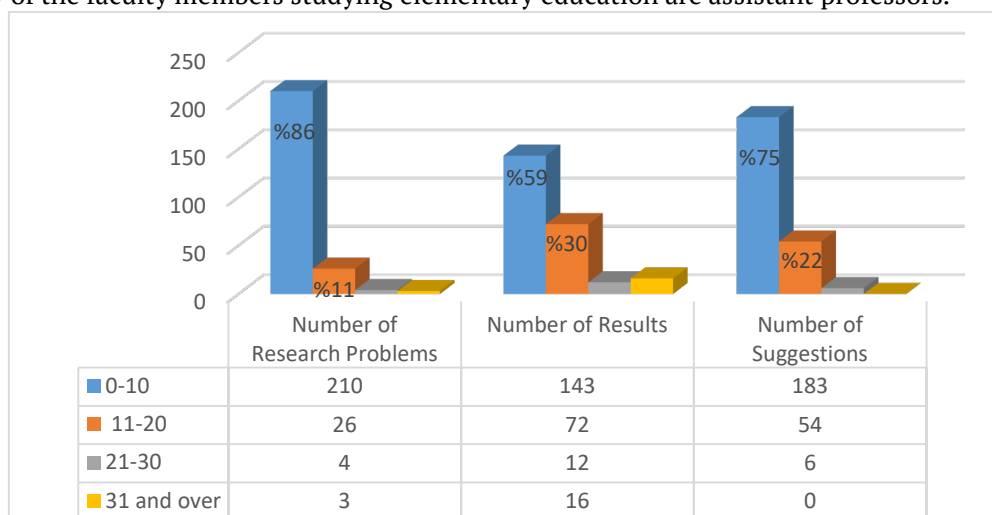
**Figure 2.** Distribution of graduate theses by genders of the authors/supervisors

As indicated in Figure 2, 151 (62%) and 92 (38%) of the researchers having carried out the theses on elementary education were female and male, respectively. This may be resulting from the fact that elementary education is considered to be more suitable for women. In fact, undergraduate programs elementary education at colleges of education are dominated by female students. It was revealed that 72 (30%) and 171 (70%) of the supervisors were female and male, respectively. The percentage of the female supervisors is not as high as that of the female authors.



**Figure 3.** Distribution of graduate theses by titles of the supervisors

Figure 3 on the distribution of the supervisors of the graduate theses in the corpus by their titles indicates that 14.4% of the supervisors are professors, 33.7% are associate professors, 50.6% are assistant professors and 1.2% are lecturers with a doctoral degree. This finding may evidence that majority of the faculty members studying elementary education are assistant professors.



**Figure 4.** Distribution of the graduate theses by research problems, results and suggestions

Figure 4 manifests that 86%, 59% and 75% of the 243 graduate theses contain 0-10 research problems, 0-10 results and 11-20 suggestions, respectively.

### ***Findings on the Third Sub-goal***

In response to the question “What is the distribution of the graduate theses in the corpus by research focus?, the researchers analyzed the contents of the graduate studies to identify the focal points of the 243 open-access graduate theses included in the corpus and archived by the Publication and Documentation Department of the Council of Higher Education. The researchers identified the foci of

the graduate theses in the corpus and grouped them into 8 categories, i.e. qualifications of elementary education teachers, effects of different approaches/methods on elementary education, characteristics of children, qualifications of class teacher candidates, analysis of education programs and lesson books in Turkey, qualifications of elementary school inspectors and administrators, the education of children who need special education / inclusive education and the others. These focal points are presented in Table 2.

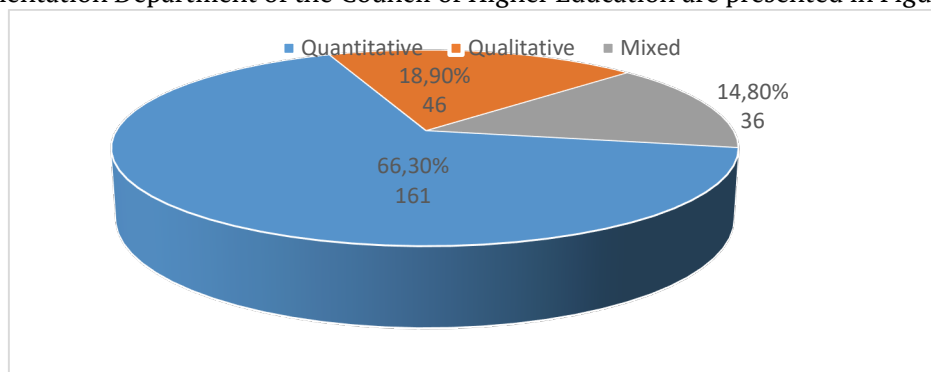
**Table 2.** Graduate theses in the corpus by focal points

Focal points	f	%
1. Qualifications of elementary education teachers	78	33
2. Effects of different approaches/methods on elementary education	47	19
3. Characteristics of children	36	15
4. Qualifications of class teacher candidates	28	12
5. Analysis of education programs and lesson books in Turkey	45	19
6. Qualifications of elementary school inspectors and administrators	8	3
7. The education of children who need special education / inclusive education	10	4
8. Others	11	5

Table 2 indicates that 33% (78) of the examined graduate theses are concentrated on the qualifications of elementary education teachers.

#### **Findings on the Fourth Sub-goal**

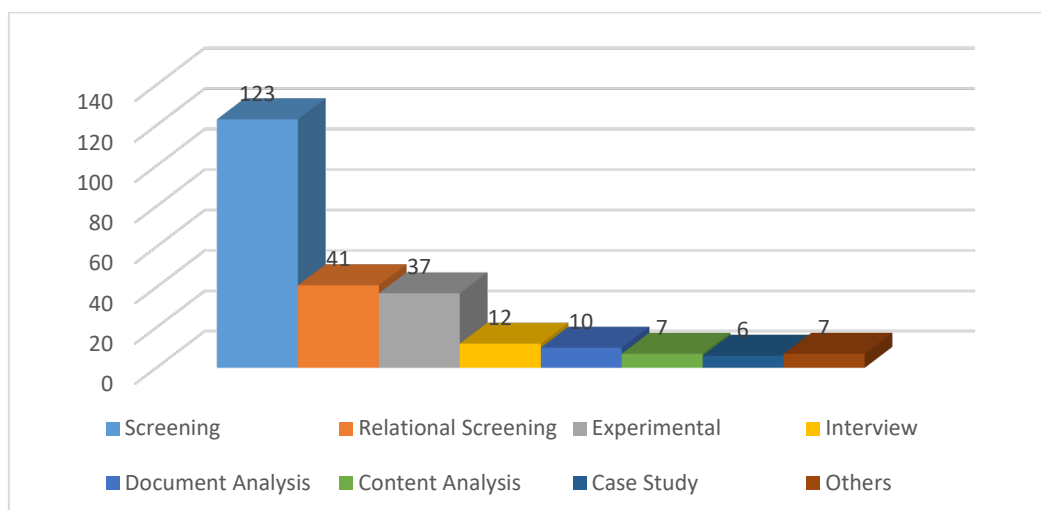
In the context of the fourth research question “What is the distribution of the graduate theses in the corpus by research models/methods, data collection methods/tools, and population/sample group?”, the findings on the scientific research types of the 243 open-access theses archived by the Publication and Documentation Department of the Council of Higher Education are presented in Figure 5.



**Figure 5.** Distribution of graduate theses by scientific research types

It is obvious from Figure 5 that most (161) of the 243 graduate theses are quantitative, accounting for 66.31%. The theses using mixed research method, account for 14.8% (36) of the examined studies. The distributions of the graduate theses in the corpus by research method are provided in Figure 6. To identify the research methods, the methods labeled as “research method” by the authors were taken into account.

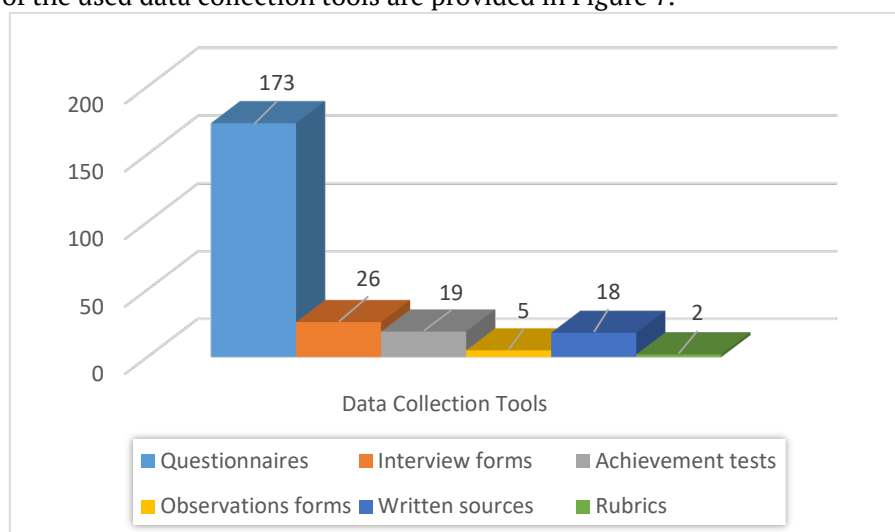




**Figure 6.** Distribution of graduate theses by scientific research methods  
(Others: Phenomenological (3), action research (2), observation (1), explanatory (1))

As observable in Figure 6, the authors of 51% (123) of 243 graduate theses used screening method. The least employed research methods were case study (2.5%), content analysis (2.9%) and document analysis (4.1%).

The analysis of the 243 graduate theses in terms of data collection tools showed that one data collection tool was used in 118 (49%) of the studies, two in 105 (43%), and more than two in 20 (8%). The distribution of the used data collection tools are provided in Figure 7.

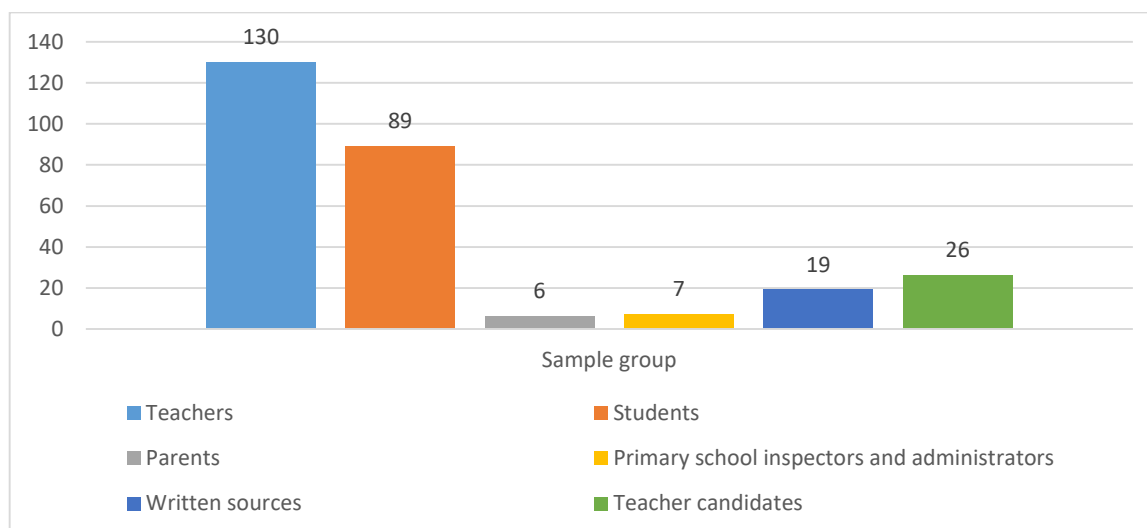


**Figure 7.** Distribution of graduate theses by data collection tools

The data in Figure 7 evidence that the most frequently used data collection tool (71%) in the graduate theses was questionnaire. The least frequent data collection tools are rubrics by 0.8%, observation forms by 2%.

Lastly, in consideration of the findings concerning the fourth research problem on the population and sampling in the corpus, it was found out that 209 (86%) of the authors conducted their studies on a single sample, 32 (13%) on two and 2 (1%) on more than two samples. The distributions by sample groups in the graduate theses are shown in Figure 8.

### An Analysis of Graduate Theses on Elementary Education



**Figure 8.** Distribution of the graduate theses by sample groups

It can be realized from Figure 8 that 53% (130), 37% (89) and 11% (26) of the theses were conducted on teachers, elementary education students and parents, respectively.

#### 4. Conclusion

In the present study, which aims to analyze the graduate theses conducted on elementary education between 2012 and 2016, 243 of a 485-thesis population were analyzed. The obtained results are as follows:

- 151 (62%) and 92 (38%) of the authors are female and male, respectively. This might have resulted from the fact that majority of undergraduate students in the department of elementary education are female.
- Half the analyzed theses have been supervised by assistant professors (lecturers with a PhD degree). The statistics of the Council of Higher Education indicate that assistant professors account for the highest percentage of faculty members employed at higher education institutions.
- The numbers of sub-problems, results and suggestions in the analyzed studies fall within the range of 0-10.
- The studies were detected to focus on 8 subject matters, i.e. qualifications of elementary school teachers, effects of different approaches/methods/practices in education, qualifications of elementary school students, qualifications of preservice elementary school teachers, educational programs in Turkey, analysis of course books, qualifications of administrators/inspectors, special education/education of inclusion students, and others. Qualifications of elementary school teachers are the focal point of every three studies.
- 161 (66.31%) of the 243 graduate theses are quantitative studies.
- Data collection tool most frequently used in the graduate studies is questionnaire, accounting for 71% of the corpus.
- In consideration of the populations and samples of the corpus, it was observed that 209 (86%) had a single, 32 (13%) had two, and 2 (1%) had more than one sample.
- It was also revealed that 130 (53%), 89 (37%), and 26 (11%) of the theses were conducted over elementary school teachers, elementary school students, and parents, respectively.

An educational system fails without teachers. Therefore, training of teachers as building blocks of the system should be prioritized. Programs employed to train teachers, architectures of societies, should be renovated in line with the requirements necessitated by the contemporary period and (re)organized in a way to train modern, intellectual, and unprejudiced teachers, who are prepared to teach. Teacher training is a fervently discussed issue always kept on the agenda all over the world (Cankaya, 2007). Thus, teachers should be encouraged to receive graduate education, conducted studies should be

analyzed by teachers, and they should be presented to teachers of the same field at schools during seminar period.

## 5. References

- Agaoglu, E. , Ceylan, M., Kesim, E., Madden, T., & Altinkurt, Y. (2005). Okul yönetimi ile ilgili lisansustu tezlerin incelenmesi. *II. Lisansustu Egitim Sempozyumu Tam Metinler icinde*. Istanbul: Marmara Universitesi.
- Aksoy, B., Sonmez, O., F., & Merey, Z. (2009). Sosyal bilgiler ogretiminde yapilan lisansustu tez konularinin 2005 yeni sosyal bilgiler ogretim programina gore degisiminin degerlendirilmesi, *IV. Sosyal Bilimler Egitimi Kongresi Tam Metinler Icinde*, (9 Ekim), Istanbul.
- Arslan, H. (2018). An Introduction to Education. London: Cambridge Scholars Publications.
- Arslan, H. and Rata, G. (2015). Interdisciplinary Perspectives on Social Science. London: Cambridge Scholars Publishing.
- Avsar, N. G. (2007). *Turkiye milli egitim sisteminde 1963-1980 ile 1980-2006 yillari arasinda ogretmen yetistirme ve atama politikalarinin degerlendirilmesi*. (Yayinlanmamis Yuksek Lisans Tezi). Inonu Universitesi, Turkey.
- Ayaz, M. F., Oral, B., & Soylemez, M. (2015). Turkiye’de ogretmen egitimi ile ilgili yapilmis lisansustu tezlerin degerlendirilmesi. *Ilkogretim Online*, 14(2), 787-802.
- Bektas, M., & Karadag, B. (2013). Hayat bilgisi ogretimi alaninda yapilan lisansustu tezlerin egilimleri ve degerlendirilmesi. *International Journal of Human Sciences*, 10(2), 113-129.
- Coskun, I., Dundar, S., Parlak, C. (2014). turkiye’de ozel egitim alaninda yapilmis lisansustu tezlerin cesitli degiskenler acisindan incelenmesi (2008-2013). *Ege Egitim Dergisi*, 15(2), 375-396.
- Cankaya, S. (2007). *Turk ve Ingiliz egitim sistemlerinde ogretmen yetistirme sistemlerinin karsilastirilmesi*. (Yayinlanmamis yuksek lisans tezi). Istanbul: Yeditepe Universitesi.
- Cifci, T. (2017). Turkiye’de cografya egitimi alaninda yapilan lisansustu tezlerin (2006-2017) egilimleri. *Journal of History Culture and Art Research*, 6(4), 864-887.
- Demir, M. K., & Ekici, B. (2015). Hayat bilgisi egitimi alanindaki tezlerin degerlendirilmesi. *SOBIDER*, 2(5), 47-65.
- Eristi, B. (2004). *Avrupa Kalite Yonetimi Vakfi mukemmellik modelinin egitim fakulteleri icin uyarlamasi*. (Yayinlanmamis doktora tezi). Eskisehir: Anadolu Universitesi Egitim Bilimleri Enstitusu.
- Goktas, B. & Erdem, R. (2006). Saglik yonetimi alaninda yapilan tezlerin profili. *Firat Saglik Hizmetleri Dergisi*, 1(1), 53-63.
- Karkin, A. M. (2011). Muzik bilimleri alaninda lisansustu tezlerin incelenmesi. *Inonu Universitesi Sanat ve Tasarim Dergisi*, 1(2), 143-149.
- Kolac, E. (2008). Ilk okuma yazma alaninda yapilan lisansustu tezlerin degerlendirilmesi. *VII. Ulusal Sinif Ogretmenligi Egitimi Sempozyumu Tam Metin Icinde*, Canakkale.
- Oruc, S., & Ulusoy, K. (2008). Sosyal bilgiler alaninda yapilan tez calismalari. *Ahmet Kelesoglu Egitim Fakultesi Dergisi*, 26, 121-132.
- Sonmez, O. F., Merey, Z., & Kaymakci, S. (2009). Vatandaslik ve insan haklari egitimi alaninda yapilan yuksek lisans ve doktora tezlerinin degerlendirilmesi. *I. Uluslararası Avrupa Birliği, Demokrasi, Vatandaslik Ve Vatandaslik Egitimi Sempozyumu Tam Metinler Icinde*, 28-30 Mayıs, Usak.
- Sahin, M., Gogebakan Yildiz, D., & Duman, R. (2011). Turkiye’deki sosyal bilgiler egitimi tezleri uzerine bir degerlendirme. *Sosyal Bilgiler Egitimi Arastirmalari Dergisi*, 2(2), 96-121.
- Tarman, B., Acun, I., & Yuksel, Z. (2010). Sosyal bilgiler egitimi alanindaki tezlerin degerlendirilmesi. *Gaziantep Universitesi Sosyal Bilimler Dergisi*, 9(3), 725 -746.

# Coding With Scratch In Primary Education: A Case Study

Jale Ipek, Gokben Turgut

## 1. INTRODUCTION

Throughout history, the development of technology has led to many positive influences, such as widespread education, facilitation, and increased gains (Trilling and Hood, 1999; Ward and Costello, 2016). Computers have become so cheap that they can go into every home, and as a result of the increase in availability, laboratories have been established in schools and many field courses such as mathematics, English, and science have begun to be processed by computer assisted education (BDE) approach. However, the tendency of the construction and operation of many sectors such as health, marketing, economy, trade, banking and tourism, not only in the field of education but also in computer-based systems, is increasing day by day with the development of technology. This leads to the need of people producing technology in the business sector. For this reason, in recent years, the development of technology has no longer been effective in educational curricula, technology education has become as important as the use of technology in schools.

Technology education aims to educate the individuals who can use the existing technologies well and can use them in a suitable way and produce solutions through a probing technology. World countries are trying to be the dominant technology producing technology and knowing industry, economy, military, etc. They are in the race to gain an absolute superiority in the fields. Because technology knowledge plays a key role in sharing the resources of the world and increasing the social prosperity (Senel and Gencoglu, 2003).

Information technology education can be divided into 2 parts: the use of information technology and software lessons. The use of information technologies; It aims to understand the technology that the student has encountered, to learn to use it, and to use the information technology in the professional, academic and daily life in the most efficient way. Software lessons are used to create games, animations, web pages, mobile applications, etc. by coding through various programming languages in order to produce the technologies used by the students. software development.

A computer system that is not capable of programming can be likened to a user who can read, but can not write; or "knowledge-literate", but not "knowledge-literate". In our day, every field has an information processing unit and it is important for an individual to know the basic software terminology so that a common language can be used with other units. On the other hand, the business world is now managing companies through complex IT networks, acquiring customers, or offering online services. In the near future, it is envisaged that there will be much more need for information specialists in the field of employment. For this reason, individuals who have been trained in a systematic way, with a good education in principle, may be instrumental in having the qualifications of our country's business capacity in this area. When we look at the developed countries on the world, it seems that children have begun to take coding courses in schools from the beginning of the school. Many institutions support projects such as Scratch, Kodable, Code.org, which provide free coding platforms, as well as educational information technology, and encourage children and their families to acquire this skill through various public spots. In addition to making a human investment for the development of the future-oriented IT sector, many studies on the field have suggested that programming education will also develop in different disciplines by increasing children's problem solving and analytical thinking skills (Attaway, 2013; Fessakis, Gouli, & Mavroudi, 2013; Frensch, 2014).

In this research, it was aimed to give a group of children in elementary school age with coding lessons in the Scratch environment and then to evaluate them by taking their experience in the education process. Scratch programming paradigms are a web-based visual programming platform that

teaches programming for children ages 8-16, provided by activities such as animation, games, interactive art that were not previously available in any medium (Resnick, Maloney, Monroy-Hernandez, Rusk, Eastmond, Brennan, Kafai, 2009). The participant group consists of 13 children and the training is arranged to cover 5 days and 20 hours. Children first defined the Scratch environment, then wrote simple games and made various applications related to mathematics. In this study, it is aimed to give opinion about the teaching of programming done with Scratch to the educators, program developers and field specialists and to convey the researcher 's experiences.

### 1.1 Problem Sentence

In the survey, the answer to the question "What are the opinions of children about learning programming in the Scratch environment?" Was searched.

Sub-problems of the study are as follows:

- 1- What are the feelings that children feel during the education process and activities?
2. What is the level of difficulty for children for the activities?
3. What are the children's views on programming?
- 4- What are the opinions of children's teaching through programming of mathematics?
5. What are the children's recommendations about education?

## 2. Method

The research qualitative method was carried out in a holistic uniformity pattern. There is only one unit of analysis, such as an individual, an institution, a program, a school in uniform situation patterns (Yildirim,& Simsek, 2011). In this study, the outputs of a single course program opened by the Ege University Children's Research Center in the summer of 2016 were examined.

### 2.1. Participants

Participation in the training and at the same time the study group was voluntary. A readily available case study is used. As students are younger than 18, permission documents have been obtained from the parents of the participants. In the group consisting of 13 primary children, ages range from 9 to 13 years. Age and gender information for children is shown in the table 1, image 1 below.

Table 1. Demographic Information

	Gender	Age
S1	F	9
S2	F	10
S3	F	10
S4	M	10
S5	M	10
S6	M	10
S7	M	10
S8	M	10
S9	M	10
S10	M	11
S11	M	12
S12	M	12
S13	M	13

## Coding With Scratch In Primary Education



Image 1. Participants

### 2.2. Course content

*Name of course:* Think, Design, Make, Make Your Own Game! (Scratch)

Day 1: Introduction to Scratch. Aquarium and number prediction game applications, image 2.

Day 2: Stage and dummy insertion. Moving the added puppet on the stage and providing disguise. Four operations and figure drawing applications, image 3.

Day 3: Area and environment calculation applications, image 4.

Day 4: Labyrinth game and base-factorial calculation application, image 5.

Day 5: Original game design on a topic to be specified. Dxball game application.

**Evaluation:** Students will be able to conduct an application that includes the topics described for five days.

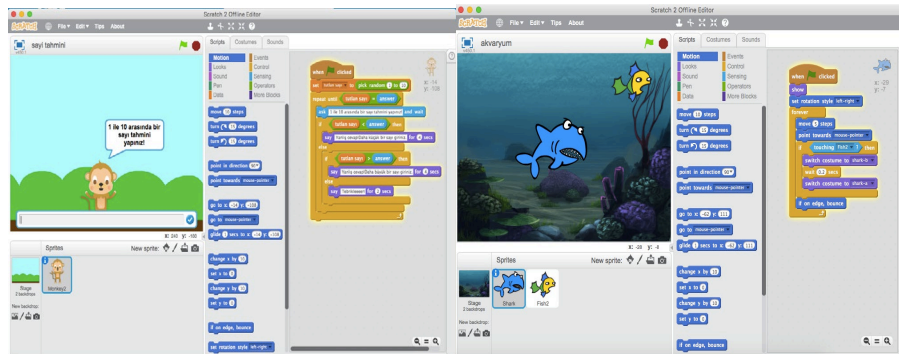


Image 2. Number Forecast and Aquarium Game Screen Views

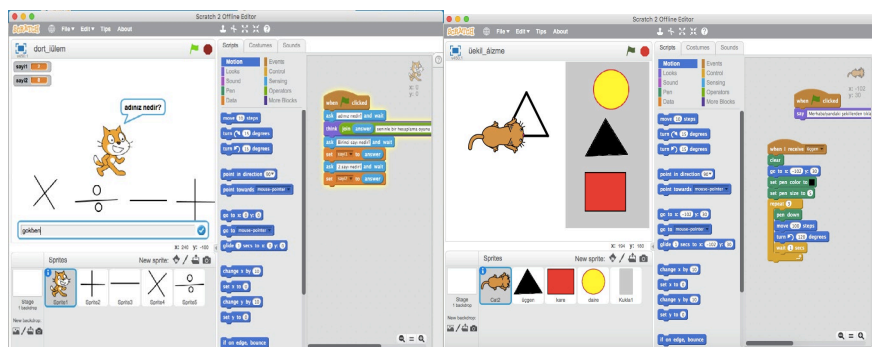


Image 3. Four Process and Figure Drawing Applications Screen Views

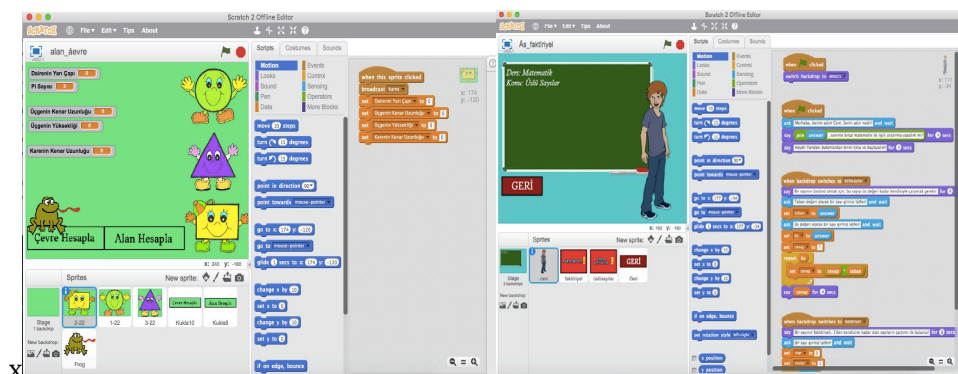


Image 4. Area-Environment Calculation and Bold Numbers Applications Screen Views

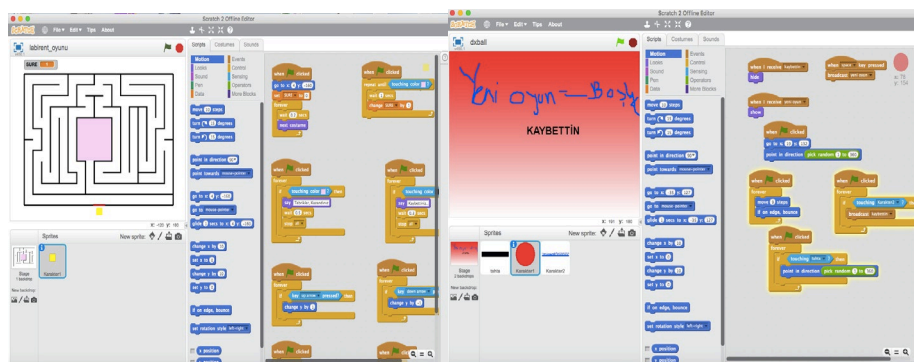


Image 5. Labyrinth and DxBall Game Screenshot

### 2.3. Data Collection Tools and Data Analysis

At the end of the training, a fully structured interview form with a total of 11 questions (8 items) was prepared in order to get the positive and negative learning experiences, feelings, suggestions and ideas about the lessons. The interview form was reviewed by the course trainer and the relevant field specialist, and necessary corrections were made. Students are asked to distribute the finalized interview form and write their ideas in writing. The collected data are divided into codes by content analysis method and then similar codes are categorized under the same themes.

### 3. Results

In this chapter; the findings obtained as a result of the analysis of the data are tabulated together with the codes, the frequencies formed under the various themes, and presented with quotations from the participants' thoughts.

#### Emotions that children feel about coding activities:

Code	F
<i>fun</i>	10
<i>happiness</i>	8
<i>wonder</i>	7
<i>success</i>	5
<i>strain</i>	3
<i>boring</i>	3
<i>failure</i>	1
<i>wonder</i>	1

In the coding activities carried out using the Scratch program, children stated that they had the most amusement, happiness, curiosity and success. 3 children said that they felt squeezed and strained and 1 child felt unsuccessful and confused. Children expressed the causes of these feelings as

## Coding With Scratch In Primary Education

follows: "Happiness; because I made my first plays [Scratch] on it. Boring; I'm mostly late." S2

"Because I learned the fun things I did not know." S3

"The reason for the hardship was that it was long and complicated. For fun we played the game we did." S4

"Because I wondered what we would do. I felt myself successful because I made a game ... "S6 ; " ... for designing the game." S7

"Because if I write a program and it works, I feel successful, happy and fun." S11

"The reason for the boredom was that the programs were so complicated because I was curious as to what kind of game it would be at the end of the reason for the curiosity." S12

"... there were commands that I did not understand in the Scratch program. And I wondered about these things. I'm happy to learn, and I'm tired of things I do not understand"... S13

**Activities that children love:**

<b>Code</b>	<b>F</b>
<i>Labirent Game</i>	7
<i>All</i>	4
<i>Number Prediction Game</i>	1
<i>Design Your Own Game</i>	1

While most of the children said they like the "Labyrinth Game" activity, 4 children expressed that they liked all activities (all) and 1 child liked "Number Estimating Game" and "Design Your Own Game" activities. The following table shows the reasons for the enjoyment of these activities:

<b>Code</b>	<b>F</b>
<i>Enjoyable</i>	7
<i>Strain</i>	1
<i>Being easy</i>	1
<i>Become a top-level game</i>	1
<i>It's a realistic game</i>	1
<i>Feeling free</i>	1

Mostly children have linked an activity's likes to fun. Other children have stated reasons such as difficulties in the event, ease of action, high-level play and realistic gameplay and free feelings.

"Because it was the most fun game for me [maze game]."

"Because it was difficult to construct." S9

"Because the person is doing what he wants." S10

"Because it was the most realistic game. The top level game was also played [labirent game]. I also enjoyed it a lot." S12

"The reason is an activity that I can understand. More things were happening than others. "

**Activities that are easy for kids:**

<b>Code</b>	<b>F</b>
<i>Number Prediction Game</i>	<u>3</u>
<i>Labirent game</i>	<u>3</u>
<i>Aquarium</i>	<u>3</u>
<i>No</i>	<u>2</u>
<i>All</i>	<u>1</u>
<i>Dxball</i>	<u>1</u>

Number prediction game, labirent game and aquarium activities are easy to get to 3'er children, 2 kids have difficulty of all activities, 1 child has no difficulty in activity, 1 child says that Dxball game is easy for him.

"I think none of it was easy. Because they all needed labor." S6

"I had difficulty in all but helped." S7

"The only activity is the aquarium (when the dogfish [,] is eating the fish)" S13



**Activities that kids do not like:**

<b>Code</b>	<b>F</b>
<i>No</i>	11
<i>Number Prediction Game</i>	1
<i>Exponential Factorial Number</i>	1

A large proportion of the children stated that they did not like any activities that they did not like [none] and that 1 child did not like the number prediction game and the wild-factorial activity. "Stiff and factorial [factorial] numbers" S4

"Yes it's okay. Number guessing game "S13

**The programs children want to write with Scratch**

<b>Code</b>	<b>F</b>
<i>Various games</i>	5
<i>War game</i>	2
<i>Five Nights at Freddy game</i>	2
<i>I do not know</i>	2
<i>Scratch himself</i>	1
<i>Compelling games</i>	1
<i>Fire and Water game</i>	1
<i>Atari Breakout game</i>	1
<i>Make-up game</i>	1

Almost all of the children expressed that they wanted to program the game and only 1 child wanted to program Scratch himself.

"Fire and Water, because my brother likes this game very much."S6

"... I wanted the Scratch program, the games we played in our daily lives, and the make-up program."S13

**Expressions used by children in programming definitions:**

<b>Code</b>	<b>F</b>
Brain	5
Action Steps	3
Enjoyable	2
Doing Useful, Useful Things	2
Coding	2
Computer	2
Freedom On The Computer	1
A Long Job	1
Complex	1
Design Software	1
Math	1
Create	1
Algorithm	1
I Do Not Know	1

When children are asked to define the concept of programming; The definition of 5 children is focused on brain expression, 3 children use the expression of process steps, 2 children see as entertainment elements, 2 children use coding statement, 2 children associate programming with the computer completely, 1 child defines programming as freedom on the computer, a long work, complex, software design, mathematics, creation, algorithmic expressions. If only one child answered this question, I do not know.

"I think programming is what people do fun, useful, useful things using mathematics."S9

## Coding With Scratch In Primary Education

"Coding the character in the computer to do what it wants" S2

"Programming is to have our brain do things by programming things that are done" S5

### The views of children about using and teaching math with Scratch:

Code	F
<i>Positive</i>	12
<i>Negative</i>	1

The use of math nearest the children with Scratch was positive, only 1 child had a negative opinion.

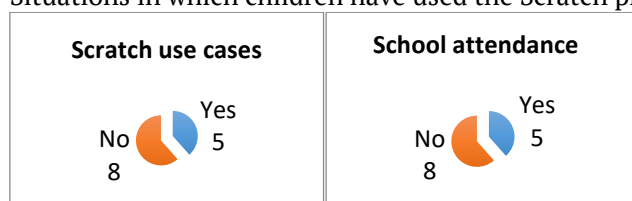
"I do not like this. I do not like the Scratch program because I do not like mathematics." S12

"Learning by having fun" S7

"Something good. Perhaps you are doing calculator." S4

"I think it should be used. Because mathematics is a very unfavorable lesson and it can be explained on the computer." S11

Situations in which children have used the Scratch program before instruction and coding at school:



Looking at the similarity and the data of the two graphs, it is seen that the children who have already met Scratch program use Scratch in their coding courses in their schools. At the same time, all the children who did not take the coding course in their school also stated that they wanted to take the coding course in the school.

### Children's willingness to receive a similar Scratch training:

Code	F
<i>Definitely yes</i>	6
<i>Yes</i>	5
<i>Maybe</i>	2

### Education recommendations for children:

Code	F
<i>No suggestion</i>	10
<i>Have suggestion</i>	3

While most of the children do not make suggestions [there is no recommendation] 3 children have made suggestions about the processing of the course.

"Only the projection should be more beautiful." S9

"I think we should be taught to do" S10

It would be better if it was a good education but it would be better if it was a computer speaker and camera." S5

## 4. CONCLUSIONS AND RECOMMENDATIONS

A group consisting of primary schoolchildren was instructed to teach coding on the Scratch platform and then students were asked to indicate their views on the activities during the course through a fully

structured interview form. The data obtained from the opinions of the children were analyzed by content analysis method and divided into codes under 10 themes.

Children's feelings about the events in general are positive sentiments such as curiosity, hearing, enjoyment and achievement, and children are sometimes challenged and bored with problems that require high mental activity. Some children have also been shown to be tolerated without mental difficulty. Teaching and learning programming requires complex and difficult activities. As Kaucic and Asic (2011) have pointed out, recent research shows that visual programming is more effective than classical context-dependent programming, students are more motivated, less squeezed, and do not have to deal with the syntax rules of programming languages.

During the course, children were involved and motivated when scheduling games or solving various algorithmic problems. Especially in games programming-based events, they have more fun, reaching the result, excited to play the game they write. This is why children expressed that their favorite activities were the lessons they had programmed. The children have tried to solve the problems and have experienced the sense of accomplishment when they discover the correct sequence of blocks. Meerbaum-Salant, Armoni and Ben-Ari (2011) used Scratch, one of the visual programming environments in their research, and stated that students did not experience learning through discovery in the medium. Similarly, in the study conducted by Gulbahar and Kalelioglu (2014) with 49 children studying in Ilkogretim 5th class, positive results were achieved as children liked to program, to develop themselves in this field, and to use Scratch easily.

The Turkish Language Institute has two definitions for programming: "a sequence of commands used to perform a computer operation" and "a section of a task to be performed, a draft that shows the sequence and timing of the sections, and the timing". Prensky (2008) defines "the creation of every digital technology to adapt to the needs and desires of a digital technology. Some describe it as human-machine interaction, some are procedural literacy, others are programming." Participant children have experienced through programming, experiencing, practicing, exploring, and making the correct definition of the concept in their cognition. The expressions "brains, software, creation, computer freedom, algorithms, process steps, mathematics, etc." that students use in their definitions show that children - in parallel with the real world -

The children evaluated the programming efficiency of the game with the prerogative of having fun. So he likes lessons he likes more. Favorite events are all maze games, number guessing games, etc. There have been lessons designed for games. In terms of age level for children, games are a kind of software that includes meaningful, useful, daily life and entertainment elements. The drawing and 3D modeling software for an architect can be said to be very meaningful for children, as long as it is necessary and meaningful. MIT, Moaloney from Media Laboratory, Burd et al., Found that animated story-making, games and interactive music, pictures, etc., (2004) stated that their work in the Scratch projects where artwork was done motivated the students.

In the study, it was observed that the children stated that they mostly wanted to schedule games with Scratch in the future. Werner, Campe, and Denner have successfully demonstrated the complexities of computer science concepts by programming games with Alice, a similar environment in their research on 325 children (2012). It can be said that for this kind of K-8 age group, program activities such as Scratch can be enjoyed like games and games, and meaningful sample activities should be selected. Although children are directly involved in mathematics and exemplify practices in the context of activities they love, they are most positive about learning through abstract, comprehension, and sometimes difficult mathematical programming. McCoy and Burton (1988) stated that programming works using mathematics and that it can be learned better by applying mathematics programming in a group of 6-8 year olds.

When the existing curriculum of the Ministry of National Education's Information Technologies and Software course is examined, it appears that the environments programmed by professionals such as Dreamweaver, Visual Basic are used (EBA, 20). Participant children who are trained also want to have programming lessons with Scratch in their schools. Scratch is a free web based software that allows you to host many sample projects, allow developers to communicate with other users by publishing their

projects, have a large number of tutorials on various video sharing sites, allow children to develop themselves at the border, it has many advantages. In the context of these research results, it is thought that Scratch should be taken to the National Curriculum and that the programming bases can be given to the children in an environment more suitable for their ages.

Participants in the study were primary school students in 4th-7th grade. class age group. It is recommended that future investigations involving in-depth studies at each grade level are proposed. In addition, studies that assess the contributions of frequent programming to problem solving and analytical thinking skills will enable more exposure to this area.

## References

- Attaway, S. (2013). *Matlab: a practical introduction to programming and problem solving*. Butterworth-Heinemann.
- EBA (2016). *Egitim Bilisim Agi*. 10 15, 2016 tarihinde EBA: <http://www.eba.gov.tr/ekitapdetay/2353> adresinden alindi.
- Fessakis, G., Gouli, E., & Mavroudi, E. (2013). Problem solving by 5–6 years old kindergarten children in a computer programming environment: A case study. *Computers & Education*, 63, 87-97.
- Maloney, J., Burd, L., Kafai, Y., Rusk, N., Silverman, B., & Resnick, M. (2004, January). Scratch: a sneak preview [education]. In *Creating, connecting and collaborating through computing, 2004. Proceedings. Second International Conference on* (pp. 104-109). IEEE.
- McCoy, L. P., & Burton, J. K. (1988). The relationship of computer programming and mathematics in secondary students. *Computers in the Schools*, 4(3-4), 159-166.
- Premsky, M. (2008). Programming is the new literacy. *Edutopia magazine*.
- Resnick, M., Maloney, J., Monroy-Hernández, A., Rusk, N., Eastmond, E., Brennan, K., ... & Kafai, Y. (2009). Scratch: programming for all. *Communications of the ACM*, 52(11), 60-67.
- Sternberg, R. J., & Frensch, P. A. (2014). *Complex problem solving: Principles and mechanisms*. Psychology Press.
- Senel, A., & Gencoglu, S. (2003). Kuresellesen dunyada teknoloji egitimi. *Gazi Universitesi Endustriyel Sanatlar Egitim Fakultesi Dergisi*, 11(12), 45-65.
- Simsek, H., & Yildirim, A. (2011). Sosyal bilimlerde nitel arastirma yontemleri. *Ankara: Seckin Yayincilik*.
- Trilling, B., & Hood, P. (1999). Learning, Technology, and Education Reform in the Knowledge Age or "We're Wired, Webbed, and Windowed, Now What?" *Educational Technology*, 39(3), 5-18.
- Ward, M., & Costello, E. (2016, April). Education Reform with Technology—Difficult but Worth the Effort. In *Global Learn* (Vol. 2016, No. 1, pp. 71-78).
- Werner, L., Campe, S., & Denner, J. (2012, February). Children learning computer science concepts via Alice game-programming. In *Proceedings of the 43rd ACM technical symposium on Computer Science Education* (pp. 427-432). ACM.



# ESL And EFL Learners' Perceptions Of Effective Foreign Language Teaching

Burcu Aydin

## 1. Introduction

Teaching is a very complicated process which is influenced by many factors. The act of teaching is personal, emotional, physical, practical, behavioral, political and cultural. Moreover, language teaching is even more complex as it is both shaped by teachers' views of the nature of language, and by their knowledge of the particular sociocultural setting (Adamson, 2004) and also by learners' attitudes, perceptions and beliefs in language learning (Wesely, 2012).

Researchers believe that predetermined ideas about language learning influence learner's effectiveness in the classroom, for instance, a student who believes that learning a second language requires learning vocabulary will give importance to vocabulary learning (Horwitz 1988). Williams & Burden (1997) stated that learners' perceptions and interpretations influence their success to a great extent and in some occasions, students' perceptions of teacher behaviors do not correspond with the teacher's intentions. Schulz (1996) stated that disagreements between students' and teachers' expectations can, unfortunately, affect L2 students' satisfaction with the language study. Therefore, learners' ideas and beliefs about the effectiveness of instruction are believed to contribute to the current teaching policies most of which aim to be more communicative, student-centered and more democratic. To what extent the learners' beliefs about the language teaching approaches are in accordance with the current system should be questioned. Noel (2014) stated that teachers are forced to evaluate their teaching strategies and find evidence that their instruction has made a positive impact on student learning to improve educational outcomes. Kissau et al. (2012) investigated the differences in beliefs of four demographic groups: experienced and inexperienced teachers, teachers with L2 teacher training and those without, teachers of different foreign languages and immersion and traditional L2 teachers. Although in their study, the survey responses were similar, the interview results revealed that members of each group have unique challenges which shape their classroom practices.

In language teaching, the terms such as foreign and second language have confused language learners' minds. The distinction in meaning should be clearly defined. Foreign language means a language which is not one's native language and learned in a formal situation. The learning is formalized for instance through a language course in school or private lesson. A second language is any language acquired later than the native language. The second language is frequently the official language of a country. In recent years second language is used for all types of non-native language learning. But if a non-native language is learned and used within a country the term second language is used whereas foreign language is used if a language is learned and used outside of the national boundaries (Stern, 2003). For this reason, foreign language students learning English in a foreign country and second language students learning English in an English-speaking country may have similar or different notions of effective teaching and learning. Their ideas and beliefs about the effectiveness of instruction may contribute to the current teaching policies. It is also believed that cultural familiarity has an effective role in learning. The aim of this study is to identify and compare the beliefs of university students learning English as a Foreign Language (EFL) in Turkey and learning English as a Second Language (ESL) in the USA.

The research questions asked in this study:

- 1) How do ESL and EFL students' beliefs about Effective Foreign Language Teaching differ from each other?
- 2) Does being exposed to target language spoken environment affect the language learners' beliefs or not?

## 2. Method

### 2.1. Study Group

To answer the question if there is a difference in beliefs between ESL and EFL settings about Effective Foreign Language Teaching, the study was conducted in two different countries. 178 EFL learners (97 females, 81 males) between the ages of 20-24 and 157 ESL learners (84 females, 73 males) between the ages of 22-27 participated the study. For ESL setting, a group of volunteers, university students of English Second Language Department in USA participated the study. For EFL setting, a group of volunteers, university students of English Language Education Department in Turkey participated the study. Their beliefs on the effectiveness of the teaching and learning processes were evaluated with the 24-item Likert-scale Effective Teacher Questionnaire.

### 2.2. Design

The researcher administered 24 item 'Effective Teacher Questionnaire' adapted from Brown (2009) to 157 participants in ESL group and 178 participants in EFL group. Participants were asked to answer the questions according to their opinions about that particular question and sign it on a Likert scale with 4 grades (1- Strongly Agree, 2- Agree, 3 -Disagree, 4 -Strongly Disagree). The items on the questionnaire were categorized and separately evaluated.

### 2.3. Statistical Evaluation

Students t-test for independent variables was held to evaluate the statistically significant difference in mean scores of questions in the questionnaire. Statistical significance was assumed when  $p < 0.05$ .

## 3. Results

The results were evaluated in 7 categories as: Grammar Teaching, Error Correction, Target Language Use, Culture, Computer-Based Technology, Communicative Language Teaching Strategies and Assessment.

### 3.1. Grammar Teaching

The results of the study indicate that EFL learners prefer grammar-based approach whereas ESL learners prefer a more communicative approach. ESL learners prefer inductive teaching of grammar whereas EFL learners prefer deductive teaching of grammatical items. EFL learners prefer grammar teaching in isolation regardless of contextual support. ESL learners feel strongly that grammar practice should be embedded in real-world contexts. ESL learners prefer to exchange information without giving importance to grammatical accuracy.

**Table 1.** The table shows the mean scores and mean difference and p values of questions previously designated as "Grammar Teaching". ESL: English as Second Language, EFL: English as Foreign Language',  $\Delta$  Mean: Mean Difference/, Significance assumed at  $p < 0.05$

		Mean			
Effective foreign language teachers should:		ESL (n=157)	EFL (n=178)	$\Delta$ Mean	p
<b>Q 10</b>	<b>not grade language production (i.e., speaking and writing) primarily for grammatical accuracy.</b>	1.76	3.04	-1.28	$p < 0.001^*$
<b>Q 16</b>	<b>mostly use activities that practice specific grammar points rather than activities whose goal is merely to exchange information.</b>	3.89	1.25	2.64	$p < 0.001^*$

<b>Q 18</b>	<b>not present a particular grammar point without illustrating how the structure is used in a specific, real-world context.</b>	1.05	3.03	-1.98	p<0.001*
<b>Q 20</b>	<b>teach grammar by giving examples of grammatical structures before explaining the grammar rules.</b>	1.88	3.05	-1.17	p<0.001*

\* p< 0.05

### 3.2. Error Correction

ESL learners don't want the teacher to correct students immediately and directly when they make a mistake or produce oral errors. EFL learners prefer immediate explanations when their responses are incorrect.

**Table 2.** The table shows the mean scores and mean difference and p values of questions previously designated as "Error correction" ESL: English as Second Language, EFL: English as Foreign Language',  $\Delta$  Mean: Mean Difference/, Significance assumed at p<0.05.

	Effective foreign language teachers should:	Mean		$\Delta$ Mean	p
		ESL (n=157)	EFL (n=178)		
<b>Q5</b>	<b>not correct students immediately after they make a mistake in speaking.</b>	1.31	3.83	-2.52	p<0.001
<b>Q8</b>	<b>only correct students indirectly when they produce oral errors instead of directly (e.g., correctly repeating back to them rather than directly stating that they are incorrect).</b>	1.08	3.11	-2.03	p<0.001
<b>Q13</b>	<b>address errors by immediately providing explanations as to why students' responses are incorrect.</b>	3.12	1.17	1.95	p<0.001

\* p< 0.05

### 3.3. Target Language Use

ESL learners prefer to use target language from the first day of class whereas EFL learners prefer to use native language when they feel it is necessary. Both ESL and EFL groups think that they should begin speaking a foreign language only when they feel they are ready to.

**Table 3.** The table shows the mean scores and Mean difference and p values of questions previously designated as "Target Language Use" ESL: English as Second Language, EFL: English as Foreign Language',  $\Delta$  Mean: Mean Difference/, Significance assumed at p<0.05.

	Effective foreign language teachers should:	Mean		$\Delta$ Mean	p
		ESL (n=157)	EFL (n=178)		
<b>Q7</b>	<b>not use English in the foreign language classroom.</b>	1.10	2.23	-1.13	p<0.001
<b>Q14</b>	<b>require students to speak in the foreign language beginning the first day of class.</b>	1.17	3.06	-1.89	p<0.001



<b>Q17</b>	<b>ask students to begin speaking the foreign language only when they feel they are ready to.</b>	1.89	1.93	-.04	p= 0.356
<b>Q19</b>	<b>speak the foreign language with native-like control of both grammar and accent.</b>	1.16	2.02	-.86	p<0.001
<b>Q22</b>	<b>not simplify or alter how they speak so that students can understand every word being said.</b>	1.80	1.96	-.16	p<0.001
<b>Q23</b>	<b>use activities where students have to find out unknown information from classmates using the foreign language</b>	1.87	2.94	-1.07	p<0.001

\* p< 0.05

### 3.4. Culture

ESL learners think that teachers should devote as much time to the teaching of culture as to the teaching of language. ESL learners think that teachers should use predominantly real-life materials (e.g., music, pictures, foods, and clothing) in teaching both the language and the culture rather than the textbook.

**Table 4.** The table shows the mean scores and Mean difference and p values of questions previously designated as "Culture". ESL: English as Second Language, EFL: English as Foreign Language',  $\Delta$  Mean: Mean Difference/, Significance assumed at p<0.05.

		Mean		$\Delta$ Mean	p
Effective foreign language teachers should:		ESL (n=157)	EFL (n=178)		
<b>Q3</b>	<b>devote as much time to the teaching of culture as to the teaching of language.</b>	1.06	2.11	-1.05	p<0.001
<b>Q9</b>	<b>be as knowledgeable about the culture(s) of those who speak the language as the language itself.</b>	1.18	2.98	-1.79	p<0.001
<b>Q21</b>	<b>use predominantly real-life materials (e.g., music, pictures, foods, clothing) in teaching both the language and the culture rather than the textbook.</b>	1.18	2.99	-1.80	p<0.001

\* p< 0.05

### 3.5. Computer-Based Technology

Both ESL and EFL learners think that teachers should frequently use computer-based technologies (Internet, CD-ROM, email) in teaching the language.

**Table 5.** The table shows the mean scores and Mean difference and p values of questions previously designated as "Computer-Based Technology". ESL: English as Second Language, EFL: English as Foreign Language',  $\Delta$  Mean: Mean Difference/', Significance assumed at  $p < 0.05$ .

	Effective foreign language teachers should:	Mean		$\Delta$ Mean	p
		ESL (n=157)	EFL (n=178)		
<b>Q1</b>	<b>frequently use computer-based technologies (Internet, CD-ROM, email) in teaching the language.</b>	1.04	1.81	-0.76	$p < 0.001$

\*  $p < 0.05$

### 3.6. Communicative Language Teaching Strategies

The EFL learners prefer grammar-based approach whereas ESL learners prefer a more communicative approach. ESL learners prefer their teachers to teach the language primarily by having students' complete specific tasks rather than grammar-focused exercises. Furthermore, ESL learners prefer authentic language whereas EFL learners prefer textbooks.

**Table 6.** The table shows the mean scores and Mean difference and p values of questions previously designated as "Communicative Language Teaching Strategies". ESL: English as Second Language, EFL: English as Foreign Language',  $\Delta$  Mean: Mean Difference/', Significance assumed at  $p < 0.05$ .

	Effective foreign language teachers should:	Mean		$\Delta$ Mean	p
		ESL (n=157)	EFL (n=178)		
<b>Q2</b>	<b>base at least some part of students' grades on completion of assigned group tasks.</b>	1.36	1.99	-0.63	$p < 0.001$
<b>Q4</b>	<b>require students to use the language outside of class with other speakers of the language (e.g., Internet, email, clubs, community events, etc.).</b>	1.01	1.87	-0.86	$p < 0.001$
<b>Q11</b>	<b>teach the language primarily by having students complete specific tasks (e.g., finding out prices of rooms and rates at a hotel) rather than grammar-focused exercises.</b>	1.07	3.03	-1.96	$p < 0.001$
<b>Q12</b>	<b>have students respond to commands physically in the foreign language (e.g., "stand up," "pick up your book," etc.).</b>	1.18	1.94	-0.77	$p < 0.001$
<b>Q15</b>	<b>not use predominantly small groups or pair work to complete activities in class.</b>	3.09	1.90	1.18	$p < 0.001$
<b>Q21</b>	<b>use predominantly real-life materials (e.g., music, pictures, foods, clothing) in teaching both the language and the culture rather than the textbook</b>	1.18	2.99	-1.80	$p < 0.001$
<b>Q23</b>	<b>base at least some part of students' grades on their ability to interact with classmates successfully in the foreign language.</b>	1.87	2.94	-1.07	$p < 0.001$

<b>Q24</b>	<b>use activities where students have to find out unknown information from classmates using the foreign language</b>	<b>1.98</b>	<b>2.93</b>	<b>-.95</b>	<b>p&lt;0.001</b>
------------	--	-------------	-------------	-------------	-------------------

\* p< 0.05

### 3.7. Assessment

ESL learners think that teachers should not grade language production (i.e., speaking and writing) primarily for grammatical accuracy. ESL learners think that teachers should assess their communication skills.

**Table 7.** The table shows the mean scores and Mean difference and p values of questions previously designated as "Assessment". ESL: English as Second Language, EFL: English as Foreign Language',  $\Delta$  Mean: Mean Difference/, Significance assumed at p< 0.05.

		Mean			
Effective foreign language teachers should:		ESL (n=157)	EFL (n=178)	$\Delta$ Mean	p
<b>Q2</b>	<b>base at least some part of students' grades on completion of assigned group tasks.</b>	1.36	1.99	-.63	p<0.001
<b>Q6</b>	<b>allow students to respond to test questions in listening and reading via English rather than the foreign language.</b>	3.71	2.04	1.66	p<0.001
<b>Q10</b>	<b>not grade language production (i.e., speaking and writing) primarily for grammatical accuracy.</b>	1.76	3.04	-1.28	p<0.001
<b>Q23</b>	<b>base at least some part of students' grades on their ability to interact with classmates successfully in the foreign language.</b>	1.87	2.94	-1.07	p<0.001

\* p< 0.05

## 4. Discussion and Conclusion

The results of the current study indicated that ESL and EFL students' beliefs about 'Effective Foreign Language Teaching' differ from each other and being exposed to target language spoken environment affect the language learners' beliefs. Their perceptions of ideal teaching practices showed different views especially on gaining communicative skills and error correction. The EFL learners preferred grammar-based approach whereas ESL learners preferred a more communicative approach and also EFL learners preferred immediate error correction.

Schulz (1996) compared students' and teachers' attitudes towards grammar instruction and error correction. The results of his study indicated that learners prefer focus on form instruction in the foreign language classroom, regardless of language. The results of this study is in consistence with Schulz (1996) as EFL learners prefer grammar based approach.

The results of this study indicated that learners' perceptions and interpretations have been found to have the ultimate influence on achievement and satisfaction. This study will shed a light to the teachers in determining effective strategies in language teaching. Teachers should design their teaching content and adopt teaching strategies according to their teaching objectives and student abilities and preferences. Also, they should take in consideration the students' needs to be effective in promoting student learning. Furthermore, teachers should provide appropriate feedback to students to

help them improve. In other words, teachers should not only trust their own beliefs about predominant methodologies in language teaching but also they should consider their student feelings and perceptions. In conclusion, to increase students' involvement in learning process, teachers should discover students' perceptions regarding language teaching and learning and establish a common sense. Because systematic evaluation of student beliefs will increase student learning and satisfaction.

## 5. References

- Adamson, B. (2004). Fashion in language teaching methodology. *The Handbook of Applied Linguistics*: 604-22. Malden, M. A: Blackwell
- Brown, A.V. (2009). Students' and teacher's perceptions of effective foreign language teaching: A comparison of ideals. *The Modern Language Journal*, 93, 46-60. doi: 10.1111/j.1540-4781.2009.00827.x
- Horwitz, E.K. (1988). The beliefs about language learning of beginning university foreign language students. *Modern Language Journal*, 72(3),283-294. doi: 10.1111/j.1540-4781.1988.tb04190.x
- Kissau, S. P., Algozzine, B. and Yon, M. (2012). Similar but different: The beliefs of foreign language teachers. *Foreign Language Annals*, 45, 580–598. doi:10.1111/j.1944-9720.2013.12001.x
- Noel, A. (2014). Teacher performance assessment (edTPA): An instructor's development and evaluation of an early embedded signature assessment in an early childhood literacy course. *Journal of Early Childhood Teacher Education*, 35, 357-372. Doi:10.1080/10901027.2014.968299
- Stern, H. H. (2003). *Fundamental Concepts of Language Teaching* (12<sup>th</sup> ed.). Oxford: Oxford University Press.
- Schulz, R. A. (1996). Focus on form in the foreign language classroom: Students' and teachers' views on error correction and the role of grammar. *Foreign Language Annals*, 29, 343–364. doi:10.1111/j.1944-9720.1996.tb01247.x
- Wesely, P. M. (2012), Learner Attitudes, Perceptions, and Beliefs in Language Learning. *Foreign Language Annals*, 45, 98–117. doi:10.1111/j.1944-9720.2012.01181.x
- Williams, M., & Burden, R. (1997). *Psychology for language teachers. A social constructivist approach*. Cambridge: Cambridge University Press.



# Students' Thoughts Over Arrangement of Schoolyards

Mustafa Aydin Basar, Ergun Kaya

## 1. Introduction

The school is a "living space" for students to spend most of their time. Some of arrangements should be made for effective implementation of education in schools. Psychological factors, physical condition and mental activity of the child should be considered when making arrangements in education and training. The layout of the learning environment influences what children do. The order of the school also reflects the educational considerations of the people in that region and the educators and administrators at that school (Aslan, 2010).

The learning level of each student differs from one another. According to Gardner (2013), who redefines intelligence in this regard, each person has his/her own talent and skill. Everyone has a different way of learning, problem solving and communication with the intelligence they have. It is crucial to improve the quality of education by making educational arrangements on the basis of Gardner's "Multiple Intelligence Theory" Training should be organized according to the conditions of the region and student expectations. The school administrators are the ones who will make this happen (Uysal, 2006).

The school administrator is responsible for the entire space where the school is located. It is important to perceive the child's development as a whole during the school period. A good arrangement in the school changes the educational outlook of the student, the teacher and the family, and the basis of "quality education" is laid down. The learning environment in the school is a place that must be well thought out and designed with everything. The proper arrangement of the place is important because it will lead children to more active learning. In arranging the place, the manager should act with the principle of "learning by experience with the best learning" by collaborating with the environment and nature. Thus, place arrangement will be the part of quality education and is made in a philosophy that is constantly improving itself (Aslan, 2010).

Although the arrangement of school's environment is perceived as a whole, it should be handled separately as interior and exterior of the building. Interior place; the classes within the school, the corridors, the rooms, in short, it is the interior of the building (Uysal, 2006).

As exterior places are school gardens where children can demonstrate and develop motor skills. Children need a wide place to move easily. Outdoors often allow the child to have physical activities such as running, jumping, skipping rope, playing ball. The physical structure and order of school gardens are important to create a playground for children by acting in harmony with the educational program. In order to meet the educational expectations of children, outdoor (school garden) arrangements must take place with the participation of children, teachers, parents and managers. School gardens should be organized appropriately with the involvement of managers, with the emphasis on developing the child's personality, talents, mental and physical skills (Aslan, 2010).

As an educational environment, the idea that school and garden should be attractive to children is very old-fashioned. It can be said "the garden of the school is the student's resting place and playground" (Gollwitzer, 1959: 5) with reference to "the classroom is the living room of the child" (Pestalozzi). Besides the development of the personality, talents, mental and physical skills of the students (Aslan, 2010; Basar, 2003), socialization and sharing are very important for the ability to play with their peers.

The school garden is the observation place for the student. At the garden of a crowded school, the student observes how to behave in the community and put into practice directly. For example, when the student takes a break, it is easier to decide thanks to his/her observations in which area of the garden he/she will play, how to move with whom, and which area is safer for him/her (Turner, 1970).

The school garden is also the place of observation for teachers and school administrators. A great deal of topics can be observed in the garden, mainly student attitude, behavior, movement and social relations. It is possible to estimate the quality and success of education in a school from the cleanliness of its garden, its order, and the surrounding wall (Alpaslan, 1973: 39-40).

During the course, the students and teachers who are still in the classroom environment relieve their physical and psychological tiredness in here. The student who sits and gets bored in the same place throughout the lesson will discharge and have time with his/her friends at the school garden. This will increase the interest, attention and commitment of the student to the lectures, School gardens are places for students to take advantage of educational activities, as well as social interaction during leisure and resting periods. These areas should be designed to provide students with the opportunity to participate in a variety of activities such as forested and grassed areas, recreational areas and seating groups, arbors, playgrounds, indoor and outdoor sports areas, walking and cycling trails, allotment gardens, meteorology corners, sand pool, zoo, multipurpose hall, ceremony area, Ataturk's bust and flagpoles, traditional children's play area, flower beds, open classrooms and amphitheater, fire brigade, service and personnel parking lot and control club, etc. (Basar, 2003, MEB, 2012, 1992, 1985, Ramsey & Rydeen, 1989).

The security of students in the school is a problem that must be firstly considered and interfered with. The most important and the first thing to be considered in securing the students' safety is the school's surrounding wall. Stone, brick, briquette and wire mesh can be used as surround material. The garden wall must not be arranged as a dangerous and high to prevent unauthorized entry and undesirable situations. The interior walls of the garden walls and the railings will be surrounded by trees in different lengths and with a green belt, which will be more suitable for protection from wind and dust as well as safety and appearance. (Basar, 2003).

The arrangement of school gardens out of school education is an area where children can demonstrate and develop their motor skills. School gardens often allow the child to have physical activities such as running, jumping, skipping rope and playing ball. The order, physical structures of school gardens are important for the students to create a playground for themselves by acting in harmony with the educational program. During the course, the students and teachers who are still in the classroom environment relieve their physical and psychological tiredness in here. The school garden is also an environment where all school members meet and interact and the social interaction is intense. Students who interact with peer groups in a natural environment can develop their competences such as acquiring new friends, becoming a member of a group, and acting in accordance with the rules in this environment. However, school gardens are far from reaching students' expectations even reaching legislative standards. (Basar, 2003). It is also aimed that with this project, which is planned that student will express their thoughts and priorities by drawing arrangements of school gardens, will guide the similar researches to be carried out in the future in our country.

### **2.1. The Aim of the Study**

The aim of this study is to bring out the thoughts of primary school 4th graders and junior high school 6th graders about arrangements of school gardens by drawing pictures; so as to reveal the common and different views of primary and secondary school students. For these purposes, the following sub-questions are also included;

1. What do Primary school 4th and 6th grade students hope to find a) sporting field, b) playground, c) social-cultural field, d) nature-green field, e) educational-administrative field, f) health field, and g) artistic fields in school gardens?
2. What are the common and different aspects of primary school 4th grade and junior high school 6th grade students' thoughts on arrangements of school gardens?

### **2. Method**

It is also important to get students' opinions about the areas that they need and desire in school gardens, which are an important learning and living space for children. Students' thoughts about these

## Students' Thoughts Over Arrangement of Schoolyards

fields can be analyzed by techniques such as interviews, questionnaires or by drawing pictures. Paintings are an effective way to bring out the cognitive behavior of students as well as their affective behavior.

This study is a survey model designed to describe thoughts of 4th grade and 6th grade students of Canakkale Provincial Center about school garden concept as if there is an existing situation (Karasar, 2000). In the sample, the results of the "empty school garden visual" prepared for 3 primary and 3 middle school students in different education areas had been shown.

For the purpose of reaching the research resources, the literature search was performed first. The photographs and visual impressions obtained from related theses, journals, related researches, internet researches and studies were utilized. In addition, an empty school garden image was given to elementary and junior high school students in this study. Students were asked to draw and paint their dream school. The obtained images were transferred to the SPSS Program and necessary analyzes and evaluations were made.

A total of 140 students were given an empty school garden image, of which 73 were primary grade 4th grade students and 67 were middle school sixth grade students. A total of 102 different visual objects were drawn in the given empty school garden image; they were categorized as sports area, play area, social - cultural area, nature - green area, educational - administrative area, health area and artistic area. Then, the drawings in each area were handled separately, the frequencies and percentages were calculated and the distribution of the drawings according to the general student number was examined

### 3. Findings

The findings of the study have been tried to be revealed depending on the sub-objectives. Primary school grade 4 and middle school grade 6 students' drawings were analyzed according to the general categories of the school garden and the achieved data are shown in Table 1.

**Table 1:** Distribution of Students' Drawings According to Areas

General Distribution of Student Drawings According to Areas	Students					
	Primary School		Secondary School		General	
	f	%	f	%	f	%
Sportive Areas	119	26,2	181	45,8	300	35,3
Educational- Playground	150	33,0	65	16,4	215	25,3
Social-Cultural Area	68	14,9	52	13,2	120	14,1
Nature-Greenery Area	63	13,8	46	11,6	109	12,8
Administrative Area	48	10,5	39	9,9	87	10,2
Health area	6	1,4	5	1,3	11	1,3
Artistic Area	1	0,2	7	1,8	8	0,9
<b>TOTAL</b>	<b>455</b>	<b>100,0</b>	<b>395</b>	<b>100,0</b>	<b>850</b>	<b>100,0</b>

According to the table data, it is seen that among the 850 objects mentioned in the drawings, the most preferred objects of the students are "Sportive Areas" (35,3%) with 300 objects. It has been found that 140 students draw on average more than two (2.14) sportive objects. A total of 215 drawings were made on the "Playground" and 150 (69.8%) of the 4th grade students and 65 (16.4%) of the 6th grade students of the junior high school were found to be drawing. In addition, the least preferred choice for students related to the "artistic area" (0,9%) with 8 school garden objects.

When looking at the "sporting areas" drawing objects in the students' drawings, the maximum number of football fields (26.3%) in the drawings was reached as the result of the drawing. According to the Table 2, the football field is followed by basketball court (19,3%), swimming pool (18,0%) and volleyball court (17%).



**Table 2.** "Sporting domain" objects drawn by students

Sportive Domains	Students					
	Primary School		Primary School		Genel	
	f	%	f	%	f	%
Football field	32	26,9	47	26,0	79	26,3
Basketball court	28	23,5	30	16,6	58	19,3
Swimming pool	17	14,3	37	20,4	54	18,0
Volleyball court	-	11,8	37	20,4	51	17,0
Hiking trail	2	1,7	8	4,4	10	3,4
Tennis court	1	0,8	7	3,9	8	2,7
Gym area	5	4,2	3	1,6	8	2,7
Ping pong	4	3,4	3	1,6	7	2,3
Ice rink	5	4,2	2	1,1	7	2,3
Top room	6	5,0	-	-	6	2,0
Gym	-	-	5	2,8	5	1,7
Bicycle path	4	3,4	1	0,6	5	1,7
Golf links	-	-	1	0,6	1	0,3
Archery room	1	0,8	-	-	1	0,3
<b>TOTAL</b>	<b>119</b>	<b>100,0</b>	<b>181</b>	<b>100,0</b>	<b>300</b>	<b>100,0</b>

In the drawings, 10 (3,4%) and fewer students have arranged the walking path, tennis court, gymnastics field, table tennis, ice rink, ball room, sports hall, bicycle path, golf and archery room.

**Picture 1.** Examples of sports domain drawings

The most noteworthy arrangements related to playgrounds in children's drawings (Table 3) were swings (26.9%) and slides (22.8%). It is noteworthy that in these areas, wheeled swings, jumping, historical castle playgrounds, fighting cars, ferris wheel, toy room, gokart, tent objects were drawn only by the 4th grade students of primary school. In addition, primary school students in this area had drawn 150 drawings (69.8%) and mid-school students had drawn 65(30.2%). This suggests that primary school students in grade 4 need more toys. Secondary school students, unlike their drawings, have included small airports and non-gravity fields.

## Students' Thoughts Over Arrangement of Schoolyards

**Table 3.** "Playgrounds" objects drawn by students

Playgrounds	Students					
	Primary School		Primary School		Primary School	
	f	%	f	%	f	%
Swing	36	24,0	22	33,8	58	26,9
Slides	34	22,7	15	23,1	49	22,8
Seesaw	13	8,7	7	10,8	20	9,2
Children's play corner	13	8,7	2	3,1	15	6,9
Trampoline	9	6,0	5	7,8	14	6,7
Climb	10	6,7	3	4,6	13	6,4
Sandbox	8	5,3	2	3,1	10	4,5
Wheeled swing	5	3,3	-	-	5	2,3
Swivel slide	4	2,7	1	1,5	5	2,3
Trail playground	2	1,3	2	3,1	4	1,8
Game house	2	1,3	1	1,5	3	1,4
Bowling	1	0,7	2	3,1	3	1,4
Hoppy	2	1,3	-	-	2	0,9
Sports equipment	1	0,7	1	1,5	2	0,9
Historic castle game	2	1,3	-	-	2	0,9
Crushing cars	2	1,3	-	-	2	0,9
Ferris wheel	2	1,3	-	-	2	0,9
Toy room	2	1,3	-	-	2	0,9
GoKart	1	0,7	-	-	1	0,5
Tents	1	0,7	-	-	1	0,5
Small airport	-	-	1	1,5	1	0,5
Non-gravity field	-	-	1	1,5	1	0,5
<b>TOTAL</b>	<b>150</b>	<b>100,0</b>	<b>65</b>	<b>100,0</b>	<b>215</b>	<b>100,0</b>

Below are pictures of playgrounds drawn by students.

**Picture 2.** Examples of playground drawings

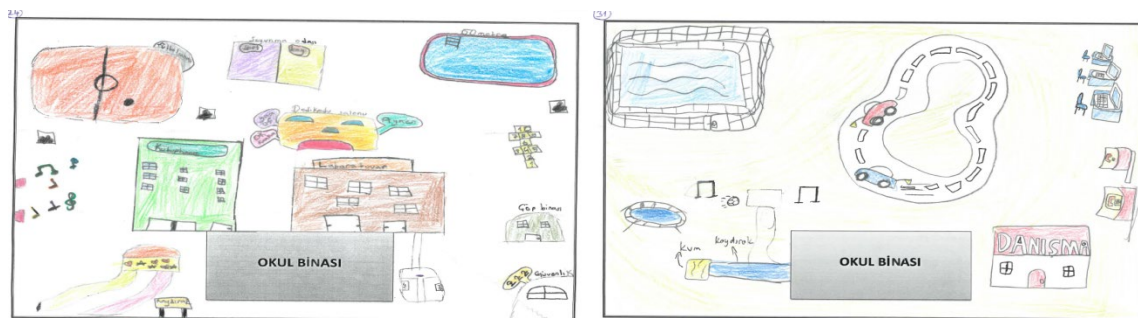
The data in Table 4 reveal that students are mostly involved in different sketch drawings (28 objects) of school gardens in the socio - cultural dimension. The gardening that most primary and secondary school students plot is "canteen". Drawings related to this garden area have been the area with the most

object diversity (28) compared to other areas. In the table, only primary school students have drawn the burger room, puff, stationery, laboratory, bear cave, intelligence room, market, ice cream place, drink place, show area, conference hall, cafeteria, gossip room, computer and arbor.

**Table 4.** "Social-Cultural domain" objects drawn by students

Social-Cultural Field Objects	Students					
	Primary School		Primary School		Primary School	
	f	%	f	%	f	%
Canteen	17	25,0	13	25,0	30	25,0
Library	9	13,2	6	11,5	15	12,5
Animal corner	2	2,9	8	15,4	10	8,3
Movie theater	5	7,3	3	5,8	8	6,7
Tribune	2	2,9	5	9,6	7	5,8
Dining hall	3	4,4	3	5,8	6	5,0
Dance hall	-	-	4	7,7	4	3,3
Hamburger hall	4	5,9	-	-	4	3,3
Puff corner	4	5,9	-	-	4	3,3
Book reading place	3	4,4	1	1,9	4	3,3
Theater Hall	2	2,9	2	3,8	4	3,3
Rest area	-	-	3	5,8	3	2,5
Stationery sales office	3	4,4	-	-	3	2,5
Multipurpose hall	1	1,5	1	1,9	2	1,7
Music hall	-	-	2	3,8	2	1,7
Lab	2	2,9	-	-	2	1,7
Bear house	1	1,5	-	-	1	0,8
Room of intelligence events	1	1,5	-	-	1	0,8
Market	1	1,5	-	-	1	0,8
Ice cream sales place	1	1,5	-	-	1	0,8
Beverage sales place	1	1,5	-	-	1	0,8
Showground	1	1,5	-	-	1	0,8
Auditorium	1	1,5	-	-	1	0,8
Cafeteria	1	1,5	-	-	1	0,8
Gossip room	1	1,5	-	-	1	0,8
Computer	1	1,5	-	-	1	0,8
Pergola	1	1,5	-	-	1	0,8
Museum	-	-	1	1,9	1	0,8
<b>TOTAL</b>	<b>68</b>	<b>100,0</b>	<b>52</b>	<b>100,0</b>	<b>120</b>	<b>100,0</b>

## Students' Thoughts Over Arrangement of Schoolyards



Picture 3. Examples of social-cultural domain drawings

When looking at the Table 5, in which the figures of nature and green area drawings are included, it is seen that the most drawn object by the primary (79,4%) and middle school (80,0%) students are "tree". This was due to low percentage of flower garden (11,9%), bridged water flow (3,6%), nature garden (2,7%). Some students also included a picnic area and aquariums in school garden drawings. In primary school students' drawings include only three objects and secondary school students drawings include six places.

Table 5. Students' Drawings "Nature - Green Space" Objects

Nature-Green Field Objects	Students					
	Primary School		Primary School		Primary School	
	f	%	f	%	f	%
Trees	50	79,4	37	80,4	87	80,0
Flower garden	10	15,9	3	6,5	13	11,9
Bridging water flow	3	4,7	1	2,2	4	3,6
Nature garden	-	-	3	6,5	3	2,7
Picnic area	-	-	1	2,2	1	0,9
Aquarium	-	-	1	2,2	1	0,9
<b>TOTAL</b>	<b>63</b>	<b>100,0</b>	<b>46</b>	<b>100,0</b>	<b>109</b>	<b>100,0</b>



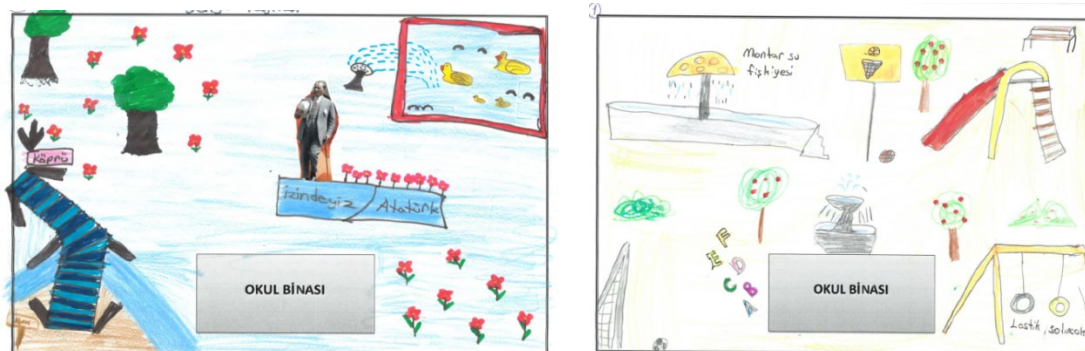
Picture 4. Examples of nature - green space drawings

According to the educational and administrative field tables, the most striking drawings among the 23 different garden drawings of the students are the banquet and fountain ornamental pool (Table 6). The most drawn object of the 4th grade students in the primary school was the fountain pool (f = 11), while the most drawn object of the 6th grade students in the middle school was the bank (f = 13).

**Table 6.** Educational and administrative domain objects drawn by students

General and administrative domain objects	Students					
	Primary School		Primary School		Primary School	
	f	%	f	%	f	%
Benches	10	20,8	13	33,3	23	26,4
Fountain ornamental pool	11	22,9	2	5,1	13	19,4
Dressing room	5	10,4	1	2,6	6	6,9
Toilets	1	2,1	5	12,8	6	6,9
Car park	-	-	5	12,8	5	5,7
Ataturk corner	3	6,2	1	2,6	4	4,6
School fountain	2	4,2	2	5,1	4	4,6
Security unit	4	8,3	-	-	4	4,6
Bicycle parking	1	2,1	2	5,1	3	3,4
Garbage collection place	1	2,1	2	5,1	3	3,4
Smart board	2	4,2	-	-	2	2,3
Security camera	-	-	2	5,1	2	2,3
Lighting	2	4,2	-	-	2	2,3
Bell building	1	2,1	-	-	1	1,1
Store	-	-	-	-	1	1,1
Advice	1	2,1	-	-	1	1,1
Telephone club	1	2,1	-	-	1	1,1
Private tuition room	1	2,1	-	-	1	1,1
Disabled way	1	2,1	-	-	1	1,1
Cable car	-	-	1	2,6	1	1,1
Elevator	-	-	1	2,6	1	1,1
Teachers' room	-	-	1	2,6	1	1,1
Meeting area	-	-	1	2,6	1	1,1
<b>TOTAL</b>	<b>48</b>	<b>100,0</b>	<b>39</b>	<b>100,0</b>	<b>87</b>	<b>100,0</b>

When the pictures of the students are examined, the garden layouts which are in the drawings of the primary school students and not in the drawings of the middle school students are as follows: Security unit, smart board, lighting, bell tower, warehouse, counseling, telephone club, private room and disabled way. Secondary school students, on the other hand, unlike primary school students, had drawn parking lot, security camera, cable car, elevator, teachers' room and assembly area.

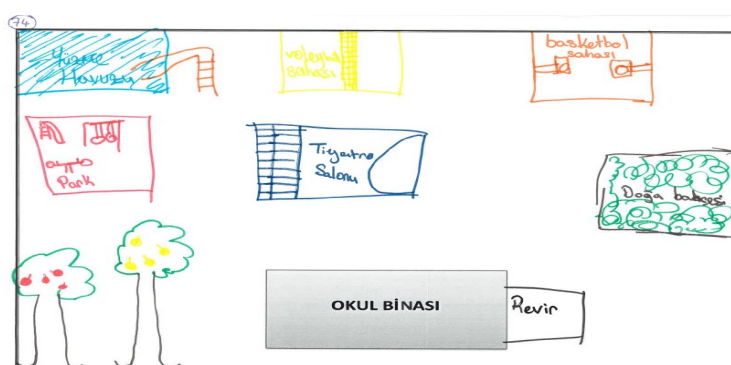
**Picture 5.** Examples of Educational and administrative domain drawings

## Students' Thoughts Over Arrangement of Schoolyards

**Table 7.** "Health domain" objects drawn by students

Health Field Objects	Students		
	Primary School	Primary School	Primary School
	f	f	f
Infirmary	3	2	5
Mini hospital	2	-	2
Emergency	-	2	2
The health clinic	1	-	1
Drug department	-	1	1
<b>TOTAL</b>	<b>6</b>	<b>5</b>	<b>11</b>

The arrangements in which pupils have at least a partial obligation in their drawings of school gardens have been related to health and artistic spaces. Because of the low frequency values, the percentage values in Table 7 and 8 are not included. According to the "health field" table above, both groups have included in their drawings and the most preferred drawing was "infirmary". In the drawings of primary school students include mini-hospital (2) and health center (1); while in the drawings of the middle school students, the drug-pharmacy unit was included.

**Picture 6.** Examples of health domain drawings

In the drawings there are only 8 arrangements for artistic domains. The object with the greatest number of drawings was the "painting art space" drawn by middle school students. Only one (1) primary school student has placed the design room in the drawing. Only one middle school student from all schools also pointed out that there should be poetry walls and colored walls in their drawings.

**Table 8.** "Artistic domain" objects drawn by students

Artistic Field Objects	Students		
	Primary School	Primary School	Primary School
	f	f	f
Art of painting	-	5	5
Design room	1	-	1
Poetry wall	-	1	1
Colored walls	-	1	1
<b>TOTAL</b>	<b>1</b>	<b>7</b>	<b>8</b>

#### 4. Conclusions and Recommendations

The results from the data and findings of the drawings made by the primary school grade 4 and 6th grade students in our study to the empty school garden visuals are as follows:

1. Regulations and objects with the greatest number of students in the pictures reflect the general situation of the schools (Basar, 2003). However, students' drawings of garden arrangements, which require creativity, also require school gardens to be rethought.
2. In a study aiming to gather the students' thoughts by their drawings related to school garden arrangements a total of 140 elementary and junior high school students were to state their thoughts with 850 object drawings. The pupils included an average of 6.1 school arrangement in their paintings.
3. Two-thirds of the students' school garden drawings were divided into sports (35.3%) and playgrounds (25.5%). There is an average 2.14 arrangement drawings per student in this area.
4. Students transfer most their playground objects to their drawings after the sporting scene in school gardens. On the other hand, health and artistic field objects are scarce. More than half of the students included trees and football field in school gardens; more than one quadrature also included basketball and volleyball fields, swimming pool, swing and slide sports field and playground objects and arrangements in their drawings. This reflects the fact that students see the school gardens as more of a sport and playground.
5. Looking at the whole of the work, it appears that the tree is the most drawn object. Other objects and arrangements, especially trees, show that students want to see school gardens equipped with green spaces.
6. According to secondary school students, elementary school students have twice as many places in their paintings, arrangements and objects that express playgrounds. The elementary school students in the game age, in a sense, transferred their developmental characteristics to their paintings. In secondary school students, the drawings related to sportive areas come to the forefront.

Based on the findings and conclusions, the proposals developed can be listed as follows:

1. Elementary and junior high school students in general should have enough sporting space and playgrounds in school gardens, depending on their interests, because they like gaming and sporting activities. School principals, class teachers and physical education teachers should take responsibility in order to take initiatives on topics that can respond to the students' requests.
2. The results of this study should be taken into consideration by education and school administrators and school garden regulations should be re-evaluated. Education and school administrators should consider student opinions and expectations in the planning of school gardening arrangements.
3. Artistic arrangements and practices should be more visible in the school gardens in order to increase students' attention to the artistic areas.
4. Students want to see green spaces in school gardens. Since most students, especially students, draw trees in the school garden, it means that they care about trees and greenery, so school gardens must be planted and green areas must be replicated.
5. Research in schools and education should include more studies that students can demonstrate their creativity.

#### 5. References

- Algan, A. ve Uslu, C. (2009). İlkogretim okul bahcelerinin tasarlanmasina paydas katilimi: Adana ornegi. *Akdeniz Universitesi Ziraat Fakultesi Dergisi*, 22(2), 129–140.
- Alparslan, I. (1993). *Okullarda gozlem*. Erzurum.
- Aslan, F. (2010). *Okul oncesi egitim kurumlarinda dis mekan tasariminda cocuklarin beklentilerinin belirlenmesi*. Doktora Tezi, Ankara Universitesi, Fen Bilimleri Enstitusu, Ankara.
- Basar, M. A. (2000). İlkogretim okullarinin isgoren ve fiziki olanaklari. *Pamukkale Universitesi Egitim Fakultesi Dergisi*, 8, 1-7.
- Basar, M. A. (2003). *Ilkogretim kurumlarinin olanaklari*, Doktora Tezi, Ankara Universitesi, Egitim Bilimleri Enstitusu, Ankara.

## Students' Thoughts Over Arrangement of Schoolyards

- Buyukozturk, S. & Cakmak, E.K. & Akgun, O.E. & Karadeniz, S. & Demirel, F. (2012). *Bilimsel arastirma yontemleri. (Gelistirilmis 13. Baski)*. Pegem Akademi Yayıncılık, Ankara.
- Gollwitzer, G. v.d. (1959). *Okul bahceleri*. Cev. N. Taner ve P. Taner. Ankara.
- Gardner, H. (2013). *Coklu zeka. Yeni ufuklar*. Optimist Yayinlari.
- Karasar, N. (2012). *Bilimsel arastirma yontemi. (24. Basim)*. Nobel Yayin Dagitim, Istanbul.
- Karasolak, K. (2009). *Mimari ozellikleri farkli ilkogretim okullarindaki ogrenci ve ogretmenlerin okullarinin bina ve bahceleri hakkindaki goruslerinin incelenmesi*. Yuksek Lisans Tezi, Cukurova Universitesi Sosyal Bilimler Enstitusu, Adana.
- Milli Egitim Bakanligi, (2011). *Okullar hayat olsun projesi uygulama protokolu*. Ankara.
- Ramsey, M., J. E. Rydeen. (1989). "Fernbrook elementary schools easy style makes it a prototype for growt". American school board journal. Vol. 176, Nr. 6, s.s. 36-37, Jun. Terzioglu, E. (2005). *Ilkogretim okulu binalarinin fiziksel ozellikler bakimindan degerlendirilmesi*. Doktora Tezi, Hacettepe Universitesi, Sosyal Bilimler Enstitusu, Ankara.
- Turner, C. E., B. R. Harriett ve S. L. Smith. (1970) *School health and health education*. 6th Ed. St. Louis. Turk Standartlari Enstitusu. (TSE, 2000), *Ilkogretim okullari – fiziki yerlesim- genel kurallar*. (1. Baski), Ankara, TS 9518.
- Uysal, F. (2006). *Okul oncesi cocuk egitim merkezlerinde ic ve dis mekan organizasyonlariinin egitim yaklasimlari cercevesinde incelenmesi*. Yuksek Lisans Tezi, Gazi Universitesi, Fen Bilimleri Enstitusu, Ankara.





# **An Analysis of the Optimum Piano Instructor's Characteristics from Students' Perspective**

Deniz Beste Cevik Kilic

## **1. Introduction**

Teachers are the most effective tools in engaging education into the society. For this reason, the quality of the educational system is directly proportional to the sufficiency of teachers. Teachers are the leading actors of the education system in the process of preparing students-the future of society-for life (Gencturk and Sarpkaya, 2009). Teachers can be described as qualified, ideal or high quality. Good teachers can be defined as the teachers who have the attitudes and behaviors that ensure learning by students (Ursano, Kartheiser and Ursano, 2007).

An ideal teacher is successful, creative and extroverted (Kivinen and Rinne, 1995). Teachers' personal and professional abilities play a major role. Miron (1983) suggested that the optimum teacher should be knowledgeable, critical and self-confident in addition to having strong communication skills, supporting creative thinking and being extroverted. According to Tural (2015), piano instructors should inform their students about proper studying methods. They should also follow the students' working processes until the next lesson and contribute to their development. Solving the problems at these stages might contribute to the student's success in the lesson, and also increase his/her motivation level for piano (pp.355). A study by Smith (2008) stressed the need for the optimum teachers to act as guides, be social, encourage students, value student opinions and be sensitive. Teachout (1997) categorized effective teacher qualities in music instruction in three groups: personal traits, musical traits and instructional traits. Yarbough (1975) describes the most effective personal traits of music teachers as making eye contact, being close with students, the tone and use of the voice, and gestures and facial expressions.

A review of the studies in music instruction indicates that these studies focus on students' perceptions of effective teacher qualities (Cevik Kilic, 2014; Madsen and Cassidy, 2005; Rohwer and Henry, 2004), student and teacher opinions about the concept of effective music instruction (Schmidt, 1994; Teachout, 1997), and the factors that ensure the effective performance of music instruction (Madsen, 2003; Teachout, 2001). This study was intended to determine the opinions of pre-service music teachers who chose teaching as a profession about the qualities and values involved in the concept of the optimum piano instructor.

## **2. Methodology**

### **2. 1. Study Sample**

The sample of this study included six pre-service teachers from the Music Teaching Program of the Fine Arts Teaching Department in Balikesir University's Necatibey Education Faculty in the 2016-2017 academic year. The participants were selected using purposeful sampling. Three participants were females, and the rest three were males.

### **2. 2. Data Collection Tools**

The study data (student opinions) were collected during semi-structured interviews. Punch (2005) notes that interviews can be structured, semi-structured or non-structured in qualitative studies. In semi-structured interviews, the interviewer has specific questions to ask the interviewees, and additional questions are asked if necessary (Yuksel, Mil and Bilim, 2007).

When creating the interview, the researcher consulted three field experts to see whether the interview questions were suitable for the validity of the study and finalized the form based on their suggestions. Each pre-service teacher in the study was generally informed about the interview process

at the beginning of their interviews. During the interviews, each participant was asked the questions on the interview form, and their responses were recorded.

The validity of the study was provided using credibility, the criterion of direct representation in study results, and transferability, the criterion of exterior validity (Yildirim and Simsek, 2006). This study attempted to meet the transferability criterion by providing direct quotations from the participants. In addition, the qualitative data were digitized in an attempt to improve its reliability.

### **2. 3. Data Analysis**

The study data were subjected to content analysis after transcribing the interview records. This method makes it possible to discover concepts and themes that are not noticed in descriptive analysis (Yildirim and Simsek, 2006). The main purpose of content analysis is to determine the concepts and coding that can explain the study data. The encoding system analyzes the examples and themes as well as similar data. Then, certain words and statements of themes are formed to represent the study data. These concepts or words are the encoding categories (Bryman, 2012). In the first stage, all of the data are read compared to each other and examined individually, and encoded as themes afterwards. In the second stage, the theme codes from the study data were categorized for the optimum piano instructor. The study was strengthened with support from the outside by making use other studies after the creation of the categories (Harris, 2005). In the final stage, the categorization procedure was terminated, and the themes were examined to decide the categories in which they should be included. Then, a consensus was ensured by consulting the opinions of experts. This study has three fundamental categories for the data of the optimum piano instructor. These main categories are professional traits, personal traits and instructional skills.

The study also refrained from using the actual names of the participants. The reliability of the study was calculated using the reliability formula by Miles and Huberman (1994) ( $\text{reliability} = \frac{\text{agreement}}{\text{agreement} + \text{disagreement}}$ ). The reliability of this study is 88%. The study was determined to be reliable since its reliability rate is higher than 70%.

### **3. Findings**

The themes and sub-themes that were determined based on the study results are presented in Figure 1 in a diagrammatic manner. The main title of the figure is the qualities of the optimum piano instructor according to the students. The research problems were examined as sub-titles under this main title. The items that are provided under these titles are summarized in Figure 1 individually. The items are written regarding the descending order of their frequency (f).

**Figure 1.** The characteristics of the optimum piano instructor from students' perspective***Professional Characteristics***

Valuing the teaching profession, get students to love the teaching profession, playing the piano and explaining at the same time, being enthusiastic about teaching, having sufficient knowledge about the piano, having advanced sight-reading skills, having good piano playing skills.

***Personal Characteristics***

Being patient, tolerant, natural, trustworthy, professional, encouraging, creative, having effective communicative skills and a smiling face.

***Instructional Skills***

Being capable of engaging students in the learning process and making an effective lesson plans, being able to use a variety of methods in piano lessons and using them to guide students, using teaching strategies that consider individual characteristics, making eye contact and being positive.

**3.1. Professional Characteristics**

The items listed by the students in response to the question about the characteristics of the optimum piano instructor are getting students to love the piano (f-6), playing the piano and explaining at the same time (f-5), being enthusiastic about teaching (f-4), having sufficient knowledge about the piano (f-4), valuing the teaching profession (f-3), having an advanced sight-reading skills (f-2) and having good piano playing skills (f-1). Here are some examples for these items:

- Example 1 (Female): "Above all, the optimum piano instructor should be able to get students to love the piano. When making them love the instrument, he or she should have sufficient knowledge to convey them the benefits that piano will provide them in their future professional lives."
- Example 6 (Male): "The optimum piano instructor should be capable of teaching the students what they know. So, it is not enough only to play it. He or she should play the piano and explain the performance at the same time since the instructional dimension is more important."
- Example 3 (Female): "The knowledge and skills related to the study area are highly important for the optimum piano instructor. He or she should be enthusiastic about conveying information to students and be capable of putting information and skills in a way that gets students to love the lessons and admire him or her."

**3.2. Personal Characteristics**

According to the participants, the personal characteristics of the optimum piano instructor were being patient (f-6), being tolerant (f-6), having a smiling face (f-5), having effective communicating skills (f-5), being natural (f-4), being trustworthy (f-3), being professional (f-3), motivating the students (f-2) and being creative (f-1). Here are some examples for these items:

- Example 2 (Male): "The optimum piano instructor should work hard for the students and be patient. These two characteristics are important particularly in piano lessons. A piano instructor should be very patient. To me, the piano requires a lot of self-sacrifice, patience, hard work and time."
- Example 5 (Female): "The optimum piano instructor should always smile to the students. If he or she does so, I believe that the students will be enthusiastic about attending lessons, and the lessons will be more productive."

- Example 4 (Male): “The ideal piano instructor should be a professional. This means that the instructor is a successful player of the piano. Piano instructors should also do their daily finger exercises and studies of musical pieces. Otherwise, they will lose their skills in time. If piano instructors do their daily required exercises, they will benefit themselves and their students much more.”

### 3. 3. Instructional Skills

The students described the instructional skills of the optimum piano teacher as being capable of engaging students in the learning process (f-6), making effective lesson plans (f-6), being able to use a variety of methods in piano lessons (f-5), directing the lessons (f-4), using teaching strategies that consider individual characteristics (f-4), making eye contact (f-3) and being positive (f-2). Here are some examples for these items:

- Example 1 (Female): “I like to sight-read the musical pieces at my level because they do not distract me and motivate me as well. When I encounter the pieces that push me beyond my level, my failure reduces my enthusiasm and happiness, and it makes me lose my affection for the lessons. At this point, it is important that the optimum piano instructor plan lessons effectively and motivate students for them.”
- Example 2 (Male): “I believe that the optimum piano instructor is supposed to make sufficient use of a rich piano repertory, and this is related to being completely informed about this field of study. The instructor should attempt to teach piano pieces from all periods and make use of a variety of piano methods.”
- Example 6 (Male): “The optimum piano instructor should think about how to take the students to the highest level because you cannot use the same method with all students. We all have unique personal characteristics. To me, for this reason, the instructor that determines teaching methods that consider students’ personal differences is the optimum piano instructor.”

### 4. Discussion and Conclusion

This study was intended to examine pre-service teachers’ views about the optimum piano instructor and analyzed the study data in the categories of professional traits, personal traits and teaching skills. In the study, the students identified getting students to love the piano, playing and explaining at the same time, being eager to teach, having sufficient information about the piano, valuing the teaching profession, having advanced sight-reading and piano playing skills as the professional traits of the optimum piano instructor. Demirel (1999) has stated that the competences related to the teaching process are important for the professional knowledge of teachers. Stanton (1985) has stressed that the optimum instructor should have precise academic competence and expertise and be a very knowledgeable researcher with a high-level information about the study area. These findings support this study.

Regarding the personal traits of the optimum piano instructor, another finding of the study indicated that the optimum piano instructor should be patient and tolerant, have a smiling face, have effective communication skills, be natural and professional, have encouraging and creative characteristics and be trustworthy. There are a number of studies that support these data since they stress that personal traits are mentioned more than the others (Akbulut, 2004; Sanders, 2002; Ubuz and Sari, 2009). According to Laminac and Long (1985), the characteristics that a good instructor should have are having complete authority in class management, being enthusiastic and patient, having a smiling face and being tolerant of the students. Cumali (2002) said that healthy and effective communication is required between teachers and students. Kelchtermans (1993) emphasized that there is a close relation between teachers’ personal and professional traits. Another study (Jones and Jones, 2004) stated that it was very important for the optimum piano instructor to have communicative competence to convey knowledge to students and perform required practices such as instructional cooperation.

Regarding the teaching skills of the optimum piano teacher, another finding of the study showed that the students' expectations of their instructors included being capable of engaging students in the learning process, making effective lesson plans, being able to use a variety of methods in the piano lesson, directing lessons, using teaching strategies that consider individual characteristics, making eye contact and being positive. A study by Cetin (2001) stressed that the optimum instructor should have precise knowledge about the study area, be capable of analyzing the individual differences between students and use various methods and techniques in lessons according to the students' needs. These results from the fact that the methods used by the piano instructor in conformance with the subject of piano lessons facilitate the teaching process and help students attain more skills and experiences. It is important that the optimum piano instructor is well-equipped in this regard. All students have their own individual learning methods. The optimum piano instructor is supposed to consider individual differences when making lesson plans for the teaching and learning process since students need unique attention and have different abilities and ways of learning. Thus, piano instructors should plan teaching strategies that consider these characteristics. This will help students to acquire information, skills and experience (Hargreaves, 1986). According to Tural (2017), it will be useful for students learning piano to learn about all areas of music (pp. 245).

## 5. Recommendations

Based on the results obtained in the research process, this study suggests that:

- The views of piano instructors (who are also faculty members) should be investigated.
- Similar studies should be conducted with music teaching students from other education faculties to compare their opinions with those of the students in this study.
- Future studies should inquire how piano instructors (also faculty members) evaluate themselves.

## 6. References

- Akbulut, G. (2004). Coğrafya öğretimi ve yaratıcı düşünce. *Cumhuriyet Üniversitesi Sosyal Bilimler Dergisi*, 28 (2), 215-223.
- Bryman, A. (2012). *Social research methods*. OUP Oxford.
- Cumali, A. E. (2002). *Oğretmenlik meslegine giris*. Ankara: Pegem Yayıncılık.
- Cevik Kilic, D. B. (2014). Bir müzik öğretmeni nasıl olmalıdır?. *Eğitim ve Öğretim Araştırmaları Dergisi*, 3 (2), 87-94.
- Cetin, S. (2001). İdeal öğretmen üzerine bir araştırma. *Milli Eğitim Dergisi*, 149.
- Demirel, O. (1999). *Planlamadan değerlendirilmeye öğretim sanatı*. Ankara: Pegem Yayıncılık.
- Gençtürk, E., & Sarpkaya, G. (2009). *Sosyal bilgiler öğretmenlerinin yeterlikleri*. M. Safran (Ed.), *Sosyal bilgiler öğretimi içinde* (s. 47-64). Ankara: Pegem Akademi.
- Hargreaves, D. J. (1986). *The developmental psychology of music*. Cambridge: Cambridge University.
- Harris, A. (2005). Teacher leadership: More than just a feel-good factor?. *Leadership and Policy in Schools*, 4, 201-219.
- Jones, V. F., & Jones, L. S. (2004). *Comprehensive classroom management, creating communities of support and solving problems* (5. Edition), USA: Allyn & Bacon Company.
- Kelchtermans, G. (1993). Getting the story, understanding the lives: From career stories to teachers' Professional development. *Teacher and Teacher Education*, 9, 443-456.
- Kivinen, O., & Rinne, R. (1995). Education of the elementary-school teachers and the images of citizenship in Finland during 19th and 20th Centuries. *Scandinavian Journal of Educational Research*, 39, 237-256.
- Laminack, L. L., & Long, B. M. (1985). What makes a teacher effective inside from preservice teachers. *Clearing House*, 58, 268.

- Madsen K. (2003). The effect of accuracy of instruction, teacher delivery and student attentiveness on musicians' evaluation of teacher effectiveness. *Journal of Research in Music Education*, 51, 38-50.
- Madsen, K., & Cassidy J. W. (2005). The effect of focus of attention and teaching experience on perceptions of teaching effectiveness and student learning. *Journal of Research in Music Education*, 53 (3), 222-233.
- Miles, M. B., & Huberman, A. M. (1994). *Qualitative data analysis*. Thousand Oaks, CA: Sage.
- Miron, M. (1983). What makes a good teacher?. *Higher Education in Europe*, 8 (2), 45-53.
- Punch, F. K. (2005). *Sosyal arastirmalara giris nitel ve nicel yaklasimlar*. (Cev.: Bayrak, D., Arslan, H. B., Akyuz, Z.). Ankara: Siyasal Kitabevi.
- Rohwer D., & Henry W. (2004). University teachers' perceptions of requisite skills and characteristics of effective music teachers. *Journal of Music Teacher Education*, 13 (2), 18-27.
- Sanders, S. E. (2002). What do schools think makes a good mathematics teacher?. *Educational Studies*, 28 (2), 181-191.
- Schmidt, M. (1994). *Defining good music teaching: Four student teachers' beliefs and practices*, University of Illinois, Paper presented at the qualitative methodologies in Music Education Research Conference, May 19-21.
- Smith, C. M. (2008). *Handbook of research on teacher education: Enduring questions in changing contexts* third edition. Co-Published by Routledge/Taylor & Francis Group and the Association of Teacher Educators.
- Stanton, H. (1985). What makes a good teacher?. *Education news*, Australian education index, 19.
- Teachout, D. J. (1997). Pre-service and experienced teachers' opinions of skills and behaviors important to successful music teaching. *Journal of Research in Music Education*, 45 (1), 41-50.
- Teachout, D. J. (2001). The relationship between personality and the teaching effectiveness of music student teachers. *Psychology of Music*, 29, 179-192.
- Tural, Z. (2015). *Part B: "Evaluation of Problems for Students with Low-Motivation in Piano Training"*, pp. 345-356. Art Studies, Hasan Arslan/Mehmet Ali Icbay/Christian Ruggiero (eds.), ISBN 978-3631-67501-4 Peter Lang Edition, Frankfurt 2015.
- Tural, Z. (2017). *Part B: "Teaching and Learning: An Analysis of the Sight-Reading Problems in Piano Instruction Experienced by Students in the Music Teaching Program of an Education Faculty"*, pp. 345-357. Research on Education, Hasan Arslan/Carmen Sonia Duse/Mehmet Ali Icbay (eds.), ISBN 978-83-948896-3-0 E- BWN-Bialystok, Poland 2017.
- Ubuz, B., & Sari, S. (2009). Sinif ogretmeni adaylarinin iyi ogretmen olma ile ilgili gorusleri. *Ondokuz Mayis Universitesi Egitim Fakultesi Dergisi*, 28, 53-61.
- Ursano, A. M., Kartheiser, P. H., & Ursano, R. J. (2007). *The teaching alliance: a perspective on the good teacher and effective learning*, 70 (3), 187-195.
- Yarbrough, C. (1975). The effect of magnitude of conductor behavior on performance, attentiveness, and attitude of students in selected mixed chorus. *Journal of Research in Music Education*, 23, 134-146.
- Yildirim, A., & Simsek, H. (2006). *Sosyal bilimlerde nitel arastirma yontemleri* (6.Baski). Ankara: Seckin Yayıncılık.
- Yuksel, A., Mil, B., & Bilim, Y. (2007). *Nitel arastirma: Neden, nasil, nicin?* Ankara: Detay Yayıncılık.

# The Effect of Using Photos on Academic Achievement and Attitudes in Social Studies Teaching

Kenan Kangoz, Sultan Baysan

## 1. Introduction

The content of Social Studies based on the near and distant surroundings, past, present and future associated with disciplines such as geography, history and citizenship, plays an important role in the development of the child's social character (Oruc & Erdem, 2010). The emphasis in this context, is on how the realization of a meaningful learning in Social Studies teaching can be realised. Because of the cognitive aspects, social studies usually use the strategy, methods and techniques of the disciplines which adopt gaining knowledge. Social Studies is closely related to the development of the child's perception. Therefore, starting from the current, advancing to the abstract from the concrete issues give useful results.

When organizing the teaching-learning activities in the classroom the right choice of techniques plays an important role in achieving a successful outcome. There are many factors affecting the selection of teaching methods and techniques. A Social Studies teacher should choose the most appropriate method or technique of their knowledge and skills related to teaching-learning environment in the classroom, his/her own personality and talents. A teacher primarily should determine the cognitive, emotional and psychomotor purposes on the subject; then the methods and techniques that will allow the students to gain these objectives be directed. In addition, teachers in the process of choosing a technique should consider their students' developmental characteristics and levels.

Photos are used in various purposes in teaching social studies. Accordingly, photos as a visual material allows knowledge to be easy and clearly learned. Therefore, in the literature, there are many studies indicating the use of visual materials to be useful. These include Ulucay (1958), Ucisik, Unlu & Ozey, (2002), Yasar (2004), Nalcaci & Ercoskun (2005), Demiralp (2007), Ulusoy & Gulum (2009), Allen (2012), Ozden (2013). On the other hand, thanks to the visual richness added to the attention of the student learning the use of photos contributes to the creation of the more colourful learning environment. Being an easy and inexpensive material is also one of the reasons to prefer the use of photos (Ozden, 2013: 150).

Students might come with new questions examining various aspects, thus new ideas may emerge (Akbaba, 2005: 188). Photos in the learning environment are always attractive for students. Thus, the photos which are from the child's surroundings, including colour and vivid life add excitement (Yanpar & Yildirim, 1999: 42-43). In this regard it is useful to use photos in Social Studies courses.

The effective way to use photos that have the nature of the evidence in can provide educational gains for students. However, some principles should be taken into account before the selection of the photos (Safran & Koksak, 1998: 71-86). These principles make it necessary to answer questions such as: *'are the photos suitable to the topic or the unit to be taught?', 'can questions about the evidence be answered?', 'does the evidence allow reference to previously processed subjects?', 'does the content of the evidence have the format and meaning that may excite curiosity and interests in students?', 'is the evidence appropriate to the student's age and development?'*. If an inappropriate direction arises then those photos should not be used.

Photos are a good opportunity for teaching the concepts of change and continuity. At the same time, photos provide the ability to interrogate, looking at different angles, and thinking multidimensionally. In this context, photos are the most important bridges that open the door to the mind. The main problem of the research is how to achieve academic success in teaching Social Studies. In this context, efforts to upgrade the academic achievement of students will be important. The aim of



the research is to attempt to determine the effect of photos on the students' academic achievement and attitude towards the course in the "*Journey in the Turkish History*" unit in the book of the 7<sup>th</sup> grade Social Studies lesson. For the stated aim, the following sub-problems were sought in the research process:

1. *Are the experimental and the control group students different in academic achievement before the experiment?*
2. *Are the experimental and the control group students different in academic achievement after the experiment?*
3. *Is there any difference between pre-and posttest scores of the academic achievement of the experimental group students?*
4. *Is there any difference between pre-and posttest scores of the academic achievement of the control group students?*
5. *Is there a meaningful difference between the attitudes of the students in the experimental group before and after the experiment (pretest-posttest)?*

## 2. Material and Method

The effect of the photos on students' academic achievement and attitudes towards the lecture was tried to be determined by experimental design with pre-test and post-test control groups. Thus, in the one class of a secondary school 7<sup>th</sup> grade Social Studies course photos were used in the "*Journey in the Turkish History*" unit; in the other, traditional (lecture, question-answer) teaching method was applied. It has been tested whether the use of photos in social studies teaching for eight weeks is effective on the students' academic achievement and attitudes towards the course. Experimental procedures were carried out in the 2015-2016 academic year of 3 hours weekly in the Social Studies course, covering the first week of December and the second week of February. It should be noted that the subjects in each class went in parallel in both groups.

The research was carried out in Nazilli Atatürk Secondary School, which is located in the province of Nazilli, Aydın province, affiliated to the Ministry of National Education, with two separate groups of 7<sup>th</sup> grade secondary school students in total of 45. The reason why the research is done in this school is that the researcher works as a teacher. In this process, the teacher researcher carried the lectures in both groups.

A validity and reliability tested achievement test was used as the data collection tool in the study (Yaylak, 2010). The achievement test is based on the third unit of the 7<sup>th</sup> grade social studies textbook "*Journey in the Turkish History*". The unit included the subjects of "*The Turks' New Homeland Anatolia, From Beylik to the State: The Establishment of the Ottoman Empire, the Ottoman Owner of the Lands and the Seas, Despite the Differences, Visit the World, See Konya, How did we Affect, Affected? Ottoman Culture through the Language of Travellers, Changing Society Life with New Institutions*". Therefore, the test consisted of 28 questions. Apart from this achievement test, the *Social Studies Course Attitude Scale* developed by Demir & Akengin (2010) was also applied.

Six pieces of photos were used for each chapter in the "*Journey in the Turkish History*" unit. These photos are based on the evaluation criteria of photos developed by Felton and Allen (1990) in the dimension of instructional use:

1. Presenting photos: the student is explained about the historical context and the scope of the photograph.
2. Lead by key question: A key question is asked. For example, '*what do people in this picture do?*'
3. Asking students to identify persons and objects: Students list everything they see in the picture.
4. Describe what the student sees in the photo: For example, '*how did these people dress up?*'.
5. Asking questions for deduction: For example, '*what kind of clues does this photo show about the places where people work?*'.

## The Effect of Using Photos on Academic Achievement and Attitudes in Social Studies Teaching

6. Asking students if they need to change, verify, or discard the hypothesis: Observations are made to change students' hypotheses. For example, 'how do you interpret what you see in this photo?', and/or 'do you notice something new here that will change your mind?'
7. Using lesson books or other materials with hypothesis support: Students support what they described in the photo with other materials. For example, 'what tools and evidence do you use for supporting your thoughts?'
8. Revising thoughts: In this step, the focus is on developing thinking skills with interpretation questions.

Below are a few examples of the functionality of some of the photos used in the experimental group by using the above criteria. While speaking about the *Ottoman Culture through the Language of Travellers*, a presentation was given to the control group about the Ottoman culture in the language of the travellers. The students were asked what they understood afterwards. In the experimental group, subject related photos of paintings which describe the events and cultural characteristics of the period that the travellers had seen during their travels were shown to the students. When the students concentrated their attention on the reflection of photos, they were supposed to assume if they were at that time and if there were any connections, differences or/and similarities with the present.



Figure 1



Figure 2

Figures 1 and 2: Sections from everyday life in the Ottoman period (1895 and 1890 respectively) (Sources: [https://commons.wikimedia.org/wiki/File:Flickr\\_-\\_E2%80%A6trialsanderrors\\_-\\_Mosque\\_and\\_street,\\_Scutari,\\_Constantinople,\\_Turkey,\\_ca.\\_1895.jpg#filelinks](https://commons.wikimedia.org/wiki/File:Flickr_-_E2%80%A6trialsanderrors_-_Mosque_and_street,_Scutari,_Constantinople,_Turkey,_ca._1895.jpg#filelinks) [https://commons.wikimedia.org/wiki/File:PZ\\_6763\\_Cook\\_in\\_the\\_rue\\_de\\_Stamboul,\\_Constantinople,\\_Turkey,\\_1890s.jpg](https://commons.wikimedia.org/wiki/File:PZ_6763_Cook_in_the_rue_de_Stamboul,_Constantinople,_Turkey,_1890s.jpg))

Figures 1 and 2 present sections of everyday life in the Ottoman Empire. A number of questions were asked to the students regarding these photos. Some of these questions are 'Where is this place?', 'What season could be from what you see?', 'What are sold in the countertops?', 'Are they present today?', 'Where had they grown up and reached the furnace? What similarities and differences are there concerning the clothing of the people?'

In addition, regarding Figure 2, questions, such as what students see on the street, the shapes of the buildings, the infrastructure of the street, what might they used as a vehicle, and how the men's clothes are, where the women might be, were asked. It was therefore attempted to improve the students' thinking, prediction and empathy skills by these types of questions. For example, 'what might be the name of the people behind' and 'what might they talk about?', 'Can you guess the occupation of the person writing on the right?'

### 2.1. Data analysis

The collected data were converted into a data set using the SPSS program; the correct responses of the students were counted 1, and the false answers 0. The pre-test and post-test results were analysed by taking the total scores of the students in the experimental and control groups granted by the *Journey to*

*Turkish History Achievement Test.* Item analysis was carried out for the reliability of the achievement test used to measure the achievement of the experimental and control groups.

Descriptive statistics of variables were examined before responding to research questions. The smallest, largest, mean, standard deviation, skewness and kurtosis coefficients of the pre- and post-test scores of the attitude scale and the pre-test and post-test scores of the achievement test were calculated from the experimental and control groups. The results are given in Table 1 and Table 2.

Table 1: Descriptive statistics on the scores of the attitude scale in the experimental and control groups

Group	Application	N	Smallest	Largest	Mean	Std. Deviation	Skewness	Kurtosis
Experiment	Pretest	22	55,00	121,00	91,46	19,24	-,248	-,738
Control	Pretest	23	66,00	119,00	96,87	16,26	-,378	-,929
Experiment	Posttest	22	54,00	109,00	86,50	16,52	-,532	-,766
Control	Posttest	23	75,00	120,00	100,57	11,26	-,843	,902

According to Table 1, the lowest score of the students in the experimental group attitude scale is 55; the highest score is 121. The attitude scores of the students in this group are 91,46 and the scores are distributed normally according to the skewness and kurtosis coefficients. Pre-test scores of attitude scale of the students in the control group ranged from 66 to 119. In the control group where the average is 96.87, it is seen that the scores are normally distributed. In the final test, the attitude scores of the students in the experimental group seem to decrease a little. The score of the attitude scale of the experimental group varies from 54 to 119 in the final test. It is seen that the distribution of points is still normal for this application where the average is 86,50. A similar situation exists for the control group. The attitude scale of the control group ranged from 75 to 120 post-test application scores. The mean score for the control group was 100.57 and the distribution of points was found to be normal.

Table 2: Descriptive statistics on the scores of the achievement test in the experimental and control groups

Group	Application	N	Smallest	Largest	Mean	Std. Deviation	Skewness	Kurtosis
Experiment	Pretest	22	1,00	15,00	9,14	3,55	-0,29	0,11
Control	Pretest	22	3,00	23,00	9,19	4,72	1,89	4,05
Experiment	Posttest	22	11,00	27,00	21,50	4,33	-1,04	0,01
Control	Posttest	22	9,00	23,00	15,50	3,77	0,41	-0,15

According to Table 2, the scores of the students in the experimental group from the pre-test of the achievement test ranged from 1 to 15 and the average of the scores was 9.14. According to the coefficient of skewness and kurtosis, the test group of the test group has a normal pre-test application scores. The scores of the students in the control group from the pre-test of the achievement test range from 3 to 23. The average score of this group is 9.19, and the average of pre-test for the experiment and the control group is very close to each other. The pre-test application scores of the control group, according to the skewness coefficient are not normally distributed, but show a sharp and pointed distribution to the right. The experiment group's achievement test is multiplied by an increase in the points they receive from the final test. Accordingly, the achievement test scores of the test group from the last test application range from 11 to 27, with an average of 21.50. It can be assumed that scores are normally distributed according to the skewness and kurtosis coefficients. The scores of the students in the control group from the final test of the achievement test ranged from 9 to 23. It is seen that the average is increased according to the pre-test application. The average is 15.50. According to the coefficient of skewness and kurtosis, the achievement test scores are normally distributed. According to the statistics in Table 1 and Table 2, scores obtained from the achievement test are mostly normal; whereas attitude scale scores show a normal distribution of all application scores.

Criteria such as research questions, type of variables, distribution characteristics of scores are influential in deciding which statistical test is to be applied in a research. According to the purpose of the study, it was decided to compare the average scores of the test and control group for both a test and for comparison of the pre-test and post-test scores. One of the tests used for this purpose is the t test.

The distributional characteristics are taken into account when deciding whether to apply the parametric or non-parametric type of the t test. The t test, a parametric test, is based on a number of assumptions: the fact that the data are constant, the variables are on a metric scale, the sample size in each group is greater than 30, and the normal distribution of the data is the prime of these assumptions. If one of these assumptions is not met, non-parametric tests are used (Sumbuloglu & Sumbuloglu, 2009). In this study, the sample size of experimental and control groups is 22 and 23, respectively. Because of the small size of the sample, it has been decided to use non-parametric responses of the t test for independent groups. The Mann Whitney U test was used to compare the experimental and control groups; the Wilcoxon Signed Rank Test was used to compare pre-test and post-test scores within each group. The relationships between the tests applied in the study and the control group were examined. Since the number of individuals in the groups is less than 30, Spearman's correlation coefficient was used in the analysis of relations. Interpretation of the correlation results is based on the following intervals (Buyukozturk, 2006):

- $r=1,00$  (perfect positive correlation),
- $r=-1,00$  (perfect negative correlation),
- $r=0,00$  (no correlation),
- $|r| < 0,30$  (low correlation)
- $0,30 \leq |r| < 0,70$  (moderate correlation)
- $|r| \geq 0,70$  (high correlation)

## 2.2. Reliability Analysis

Table 3 and Table 4 give the results of reliability analyses. In Table 3, the reliability coefficients for the pre-test and post-test of the achievement test were calculated for the experimental group and the control group and both groups.

Table 3: KR-20 reliability coefficients of the achievement test

Group	Application	KR-20 Reliability Coefficients
Experiment	Pretest	0,60
	Posttest	0,79
Control	Pretest	0,77
	Posttest	0,59
All groups (experiment and control together)	Pretest	0,69
	Posttest	0,80

Since the test items scored 1-0 and the average difficulties of the items differed, it was decided to calculate the KR-20 coefficient. Table 3 shows that the reliability of post-test application is higher in all conditions. The lowest confidence level belongs to the final test application of the control group and the highest reliability belongs to the final test application where the experimental and control group are together. Frisbie (1988) notes that reliability coefficients are not a precise measure of how much should be. If important decisions are made about the individual, it is suggested that the test applied should be within the range of 0.85 - 0.95 for a large scale standardized test. The test, however, implies that a coefficient such as 0,50 can be deducted if a teacher-made test for classroom applications and no critical decisions are made about students (Frisbie, 1988). Accordingly, it can be said that the reliability coefficients obtained for the achievement test are sufficient for this application and the obtained scores are reliable.

Table 4: Cronbach's alpha reliability coefficients of the attitude scale

Group	Application	KR-20 Reliability Coefficients
Experiment	Pretest	0,93
	Posttest	0,91
Control	Pretest	0,92
	Posttest	0,80
All groups (experiment and control together)	Pretest	0,92
	Posttest	0,90

The lowest reliability coefficient for the attitude scale according to Table 4 belongs to the post test application of the control group and is 0,80. The highest reliability is 0.93 for the pre-test of the

experimental group. Overall, all the reliability coefficients obtained for the attitude scale are quite high. Accordingly, it can be said that the scores obtained from attitude scale in this study are reliable.

### 3. Findings and Discussion

Findings related to statistical analyses for the research questions are given in this section. The sub-problems of the research were written and immediately the findings and interpretations related to that sub-problems were stated respectively.

#### 3.1. Are the experimental group students and the control group students different in academic achievement before the experiment?

The Mann Whitney U test results for this subproblem are given in Table 5.

Table 5: Mann Whitney U Test results on the comparison of the achievement test pre-test application scores of students in the experimental and control groups

Group	N	Rank Average	Rank Sum	U	p
Experiment	22	23,66	520,50	216,500	,546
Control	22	21,34	469,50		

According to Table 5, there was no statistically significant difference between the pre-test application scores of the achievement test of the students in the experiment and control groups ( $U = 216,500$ ,  $p > 0,05$ ). Accordingly, the experimental and control group scores of the pre-test achievement test are similar. As a matter of fact, as seen in Table 2, the average of the achievement test pre-test application scores of the test group 9,14; the control group is 9.19.

#### 3.2. Are the experimental group students and the control group students different in academic achievement after the experiment?

Table 6: Mann Whitney U Test results on the comparison of the achievement test post-test application scores of students in the experimental and control groups

Group	N	Rank Average	Rank Sum	U	p
Experiment	22	30,07	661,50	75,500	,000
Control	22	14,93	328,50		

According to Table 6, there is a statistically significant difference ( $U = 75,500$ ,  $p < 0,05$ ) between the post-test application scores of the achievement test of the students in the experimental and control groups. According to the rank average, the scores of the students in the experimental group after the test are higher than the control group's post-test application scores. As it is seen in Table 2, the average of the achievement test of the post-test application scores of the experimental group is 21.50; the control group is 15.50 and the scores of the experimental group are higher. This result shows that the teaching method based on photographs is more effective in increasing the success of the students in the teaching of the topics of the 7<sup>th</sup> grade Social Studies *Journey in the Turkish History* unit than the traditional (lecture, question-answer) method.

#### 3.3. Is there any difference between the pretest-posttest scores of the academic achievement of the experimental group students?

Table 7: Wilcoxon signed rank test results on the comparison of the scores of the students in the experimental group from the achievement test pretest-posttest

		N	Rank Average	Rank Sum	Z	p
Achievement test posttest scores –	Negative rank	1	1,50	1,50	-4,062*	,000
	Positive rank	21	11,98	251,50		
Achievement test pretest scores	Equal	0				

\* Negative rank favoured.

According to Table 7, there is a meaningful difference between the scores of the students in the experimental group and the scores they have taken from the pre-test and post-test ( $Z = -4,062$ ,  $p < 0,05$ ).

According to the average of the rankings, the scores of the students in the experimental group from the post- achievement test are significantly higher than the pre-test application scores. According to this, teaching method based on photography in the teaching of subjects in the 7<sup>th</sup> grade *Journey in the Turkish History* unit has been effective in increasing the success of the students who have been educated with this method.

### 3.4. Is there any difference between the pretest-posttest scores of the academic achievement of the control group students?

Table 8: Wilcoxon signed rank test results on the comparison of the scores of the students in the control group with the achievement test

		N	Rank Average	Rank Sum	Z	p
Achievement test posttest scores – Achievement test pretest scores	Negative rank	1	1,00	1,00	-3,985*	,000
	Positive rank	21	11,50	230,00		
	Equal	0				

\* Negative rank favoured.

According to Table 8, there is a significant difference ( $Z = -3,985$ ,  $p < 0,05$ ) between the scores of the achievement test of the students in the control group and the pre- and post-test scores. According to rank average, the scores of the students in the control group are higher than the pre-test application scores of the achievement test. This result shows that the traditional (lecture, question-answer) method is also effective in increasing the success of the students.

### 3.5. Is there a meaningful difference between the pretest and posttest attitudes of the students in the experimental group?

Table 9: Wilcoxon signed rank test results on the comparison of the scores of the pretest-posttest practice scores of the students in the experimental group

		N	Rank Average	Rank Sum	Z	p
Achievement test posttest scores – Achievement test pretest scores	Negative rank	14	11,46	160,50	-1,566	,117
	Positive rank	7	10,07	70,50		
	Equal	1				

According to Table 9, there is no significant difference between the scores of the attitude scale of the students in the experimental group and pre-test and post-test scores ( $Z = -1,566$ ,  $p > 0,05$ ). Therefore, teaching method based on photography in the teaching of subjects in the 7<sup>th</sup> grade Social Studies *Journey in the Turkish History* unit is not effective in increasing the attitudes of students towards the Social Studies course.

## 4. Conclusion and Suggestions

Education has carried out a different mission since the 20<sup>th</sup> century. Transferring specific knowledge to students is not enough for the new purposes of education; it is necessary to acquire the skills needed for student life and time requirements (Aik & Edmonds, 1976). The knowledge and skills in the different areas are, as a whole, a way of meeting the needs of life that the students will need. Only a single knowledge or a skill-based education, and the society that will emerge as a result, can be called a society lagging behind today's requirements. For example, thinking skills have a different prescription because of what is expected of today's people. The vital concept of information society is thinking and creating. The existing knowledge and judgments, the individual who accepts any logic without passing the thought filter, will not be able to take the step of becoming an individual with the ability to produce (Ibrahimoglu & Ozturk, 2013: 523).

Table 10 summarises the results. As a result of this research, it has been determined that the use of photographic material in social studies classes has an effective role in student achievement, student participation in class and helping to build thinking skills.

Table 10: Summary of the results

Problems	Results
----------	---------

1. Are the experimental and the control group students different in academic achievement before the experiment?	No
2. Are the experimental and the control group students different in academic achievement after the experiment?	Yes
3. Is there any difference between pre-and posttest scores of the academic achievement of the experimental group students?	Yes
4. Is there any difference between pre-and posttest scores of the academic achievement of the control group students?	Yes
5. Is there a meaningful difference between the attitudes of the students in the experimental group before and after the experiment (pretest-posttest)?	No

In Social Studies course, which is the one of the important disciplines at the secondary school level, covering different disciplines such as history and geography, there are more concepts in nature and subject of abstract concepts in different units in the curriculum. The teaching of these concepts via photos may add great contributions. However, the correct use of photos in social studies teaching is also important. However, careless, sloppy and misguided practices will turn out to be an activity that limits the horizon of thought against the subject as the students lose their interest and attention. When used correctly, it will have an impact on improving the students' understanding and learning, helping to ensure lesson participation and creative and critical thinking and empathy building skills. In addition, students will be able to bridge the gap between different disciplines in finding out things in the photos, and will contribute positively to the development of analytical thinking skills.

The following suggestions can be made concerning the findings of this research.

1. Photos should be used in the related units in Social Studies courses to support teaching.
2. Photos should be carefully selected by the teacher for the specific topics and should be collaborated with the other teachers to create a photo pool and be used in the following years.
3. Students' attention should be always taken into consideration.
4. Photos should be used with appropriate timing, so that the lesson will be more enjoyable, the topic is prepared, the photos well-selected and be rich in quality.
5. Photos should enable students to understand the information they cannot comprehend from the textbooks.
6. When using photos, teachers should create a discussion environment and lead criticism through visuals, and reinforce students with questions.

As a result, there is no doubt that photos as being one of the visual elements in social studies teaching will contribute positively if students are prepared using visual and scientific methods and methods that facilitate understanding and conception of the subject and provide the best service to the subject. Nevertheless, it should not be forgotten that no instrument or method alone is enough, it is the best way to teach all the instruments and methods where necessary, in the form and scale of the teacher's orchestration.

## 5. References

- Aik, K. & Edmonds, S. (1976). *Critical Thinking*. London: Longman Singapore Publishers.
- Akbaba, B. (2005). "Tarih Ogretiminde Fotograf Kullanimi". *Gazi Universitesi Kirsehir Egitim Dergisi*, 6(1): 185-197.
- Allen, Q. (2012). "Photographs and stories: ethics, benefits and dilemmas of using participant photography with Black middle-class male youth", *Qualitative Research*, 1-16.
- Buyukozturk, S. (20016). *Sosyal bilimler icin veri analizi el kitabi istatistik, arastirma deseni SPSS uygulamalari ve yorum*. Pegem Yayinlari, Pegem Yayıncılık, Ankara.
- Celikkaya, T. (2013). "Sosyal Bilgiler Ogretmenlerinin Ogretim Arac-Gerec ve Materyallerini Kullanma Duzeyleri", *OMU Egitim Fakultesi Dergisi*, 32(1): 73-105.
- Demir, S.B. & Akengin, H. (2010). Sosyal Bilgiler Dersine Yonelik Bir Tutum Olceginin Gelistirilmesi: Gecerlilik ve Guvenilirlik Calismasi, *E-International Journal of Educational Research*, 1(1): 26-40.

- Demiralp, N. (2007). "Cografya Egitiminde Materyaller ve 2005 Cografya Dersi Ogretim Programi", *Kastamonu Egitim Dergisi*, 15(1): 373-384.
- Felton, R.G. & Rodley Allen, R.F. (1990) Using Visual Materials as Historical Sources: A Model for Studying State and Local History, *the Social Studies*. 84-87.
- Frisbie, D. (1988). NCME Instructional module reliability of scores from teacher-made tests. *Instructional Topics in Education*, 55-65.
- Ibrahimoglu, Z. & Ozturk, C. (2013). "Sosyal bBilgiler dersinde ornek olay yontemi kullaniminin ogrencilerin akademik basari derse karsi tutum ve elestirel dusunme becerileri uzerine etkileri". *Uludag Universitesi Egitim Fakultesi Dergisi*, 26(2): 523-547.
- Nalcaci, A. & Ercoskun, M.H. (2005). "Ilkogretim Sosyal Bilgiler Derslerinde Kullanilan Materyaller", *Kazim Karabekir Universitesi Egitim Fakultesi Dergisi*, 11: 141-154.
- Oruc, S. & Akgun, I.H. (2010). "Ilkogretim Sosyal Bilgiler 7. Sinif Ogrencilerinin Grafik Okuma Becerisini Kazanma Duzeyleri". *Uluslararası Avrasya Sosyal Bilimler Dergisi*, 1(1): 51- 58.
- Oruc, S. & Erdem, R. (2010). "Sosyal bilgiler ogretiminde biyografi kullaniminin ogrencilerin sosyal bilgiler dersine iliskin tutumlarına etkisi". *Selcuk Universitesi Ahmet Kelesoglu Egitim Fakultesi Dergisi*, 30: 215-229.
- Ozden, O.D. (2013). "Sosyal Bilgiler Ogretiminde Film ve Fotograf Kullanimi". R. Sever and Kocoglu, E. (Eds). *Sosyal Bilgiler Ogretiminde Egitim Teknolojileri ve Materyal Tasarimi*. ss. 133-163. Ankara: Pegem Akademi.
- Safran, M. & Koksall, H. (1998). "Tarih ogretiminde yazili kanitların kullanılması", *Gazi Egitim Fakultesi Dergisi*, 18( 1): 71-86.
- Sumbuloglu, K. & Sumbuloglu, V. (2009). *Biyoistatistik*. Hatiboglu Yayınevi, Ankara.
- Ulucay, C. (1958), *Cevre Incelemeleri Tarih Ogretimi*, Istanbul: Ogretmenler Dernegi Yayinlari.
- Ulusoy, K. & Gulum, K. (2009). "Sosyal Bilimler Dersinde Tarih ve Cografya Konulari Islenirken Ogretmenlerin Materyal Kullanma Durumları", *Ahi Evran Universitesi Egitim Fakultesi Dergisi*, 10(2): 85-99.
- Ucisik, S., Unlu, M., & Ozey, R., (2002). "Cografya Egitim ve Ogretiminde Fotograflarin Onemi", *Marmara Cografya Dergisi*, 5, Istanbul.
- Yanpar, S.T. & Yildirim, S. (1999). *Ogretim Teknolojileri ve Materyal Gelistirme*. Ankara: Ani Yayıncılık.
- Yasar, O. (2004). "Ilkogretim Sosyal Bilgiler Derslerinde Gorsel Materyal Kullanimi ile Cografya Konularinin Egitim ve Ogretimi", *Milli Egitim Dergisi*, 163, [http://dhgm.meb.gov.tr/yayimlar/dergiler/Milli\\_Egitim\\_Dergisi/163/yasar.htm](http://dhgm.meb.gov.tr/yayimlar/dergiler/Milli_Egitim_Dergisi/163/yasar.htm) 12.10.2017.
- Yaylak, E. (2010). *Ilkogretim Sosyal Bilgiler Ogretiminde Internet Tabanlı Ogretim Yonteminin Ders Basarisina Etkisi*. Dokuz Eylul Universitesi Egitim Bilimleri Enstitusu Ilkogretim Anabilimdalı Sosyal Bilgiler Ogretmenligi Programi. (Unpublished MSc Thesis), Izmir.





# How Well Turkish and Slovak Preservice Elementary Teachers Comprehend Class Inclusion Related to Rectangle

Asuman Duatepe Paksu, Katarína Žilková

## 1. Introduction

Educators generally believe that teachers' knowledge shapes their students' learning. One of the important component of teacher knowledge is subject matter knowledge defined by Shulman (1986). According to him knowledge of the facts or concepts of a subject and its structures form the subject matter knowledge. In addition to "*what subject is about*", "*the teacher must further understand why it is so, on what grounds its warrant can be asserted, and under what circumstances our belief in its justification can be weakened and even denied*" (p. 9). Therefore teachers should know beyond what the subject is about.

Many researchers proposed that teachers' subject matter knowledge is essential for effective mathematics instruction (e.g. Ball, Hill, & Bass, 2005). In this study preservice teachers' subject matter knowledge on inclusive relations related with the rectangle was analyzed. Particularly the focus of the study is not only the content of rectangle itself but a higher level than that; deduction related with class inclusion. Classification of quadrilaterals is one of the key subjects studied in school mathematics. Understanding inclusive classes and making deduction among them is an important indicators in Van Hiele (1986) theory. Understanding relations, ordering, abstraction and simply deduction are important characteristics for informal deduction van Hiele level (the third level). At this level students know the properties of shapes and understand logical consequences of classification of geometric shapes to classes, they can draw conclusions, they are able to create easy definitions (see van Hiele, 1999; Usiskin, 1982; Marchis, 2012; Musser, Burger & Peterson, 2001; Mason, 2002; Feza & Webb, 2005; Knight, 2006; Contay & Duatepe-Paksu, 2012).

As mentioned above, the focus of the study also involves process standards defined by NCTM (2000) rather than just a geometry content area. In geometry content standards, NCTM states the expectation as students should understand deduction and learn to use deductive reasoning before finishing high school (p. 42). In process standard of "Reasoning and Proof", the importance of logical deduction was emphasized. It is clearly highlighted that students should be able to understand and produce arguments consisting of logically rigorous deductions of conclusions from hypotheses and should appreciate the value of such arguments by the end of secondary school (p.56).

With this point of view the aim of the study was to describe how senior preservice elementary teachers from Slovakia and Turkey understand the rectangle; whether they know attributes of rectangle which are important for decision making about class inclusion and what are the differences between results from these subsamples in the context of national approaches in geometry education.

## 2. Method

### Participants

The participants of this study were 144 senior preservice elementary teachers (84 Slovak and 60 Turkish from teacher training departments Slovak and Turkish universities). The underlying reason of choosing senior teacher candidates is to assume that they acquired the subject geometry matter since they completed all related courses.

### Measuring Instrument and Data Analysis

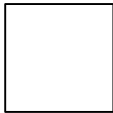
In order to collect data 6 questions from polygon and quadrilateral test constructed by Žilková (2011) was used. These items were questioning the class inclusion between rectangle and its upper and lower class shapes namely; polygon, parallelogram and square. Briefly there are 3 questions on class inclusion between rectangle and square; two questions on class inclusion between rectangle and parallelogram and one question on class inclusion between rectangle and polygon. Cronbach's alpha value of the whole test was 0.86. Due to page limitations questions are displayed in findings section along with the result of data analyses and interpretation. For data analyses the correct response percentage for each item was calculated to see how well preservice teachers know about rectangle and related class inclusion relations. Beside that chi-square test of independence was performed to see whether samples from different country was significantly different or not.

### 3. Findings

This section is divided into two parts. In the first part findings related with participants understanding of class inclusion between rectangles and its lower class quadrilateral namely square is given and interpreted. In the second part, findings related with understanding of class inclusion between rectangles and its upper class quadrilaterals. As upper class of quadrilaterals we examined parallelogram and polygon in separate sections.

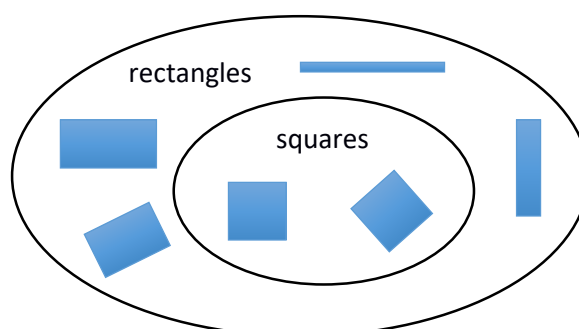
#### *Class inclusion between rectangles and its lower class quadrilateral: square*

There were three questions to determine the participants' comprehension of class inclusion between rectangle and square. These questions are displayed in Figure 1.

15. Square is ____ a rectangle. a. always   b. sometimes   c. never	5. Which words describe the shape? a) rhombus b) quadrilateral c) parallelogram d) rectangle	
16. Rectangle is ____ a square. a. always   b. sometimes   c. never		

**Figure 1.** The questions on relationship between square and rectangle

Mainly questions appeared in two different ways. Question 15 and 16 are word questions asking logical deduction concerning the inclusive relation between square and rectangle. On the other hand, question 5 display a model of square and ask to select alternative/alternatives to describe it. Although the format of these questions were different, they all required the sound understanding of hierarchical relations displayed by Venn diagram in Figure 2. As the figure tells square is a subset of rectangle that means a square is a rectangle and some type of rectangles are square but some are not.



**Figure 2.** The hierarchical relationship between square and rectangle

The correct response percentage and result of chi-square test of independence of Slovak and Turkish samples on these questions were displayed in the Table 1. The results showed that the Slovak sample had significantly better results than Turkish sample in items focused on inclusion between rectangle and square. For the interpretation of results it is important to consider the differences between definitions of rectangle and square in both countries.

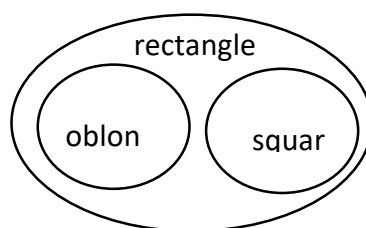
**Table 1.** The results related with class inclusion between rectangle and square

Item	SVK (%)	TUR (%)	$\chi^2(1)$	p
5d	87	13	76,981a	< .001
15	93	63	19,477a	
16	59	23	18,692a	

According to Slovak national terminology (Medek et al., 1975) there are these definitions:

- square is regular quadrilateral;
- oblong is parallelogram with all interior angles right, but not a square;
- rectangle is square or oblong (see Figure 3).

It means, there is a special name (oblong) for rectangle, which is not a square. The term rectangle is not used in national curriculum for primary, lower or upper secondary school. It is used only in some textbooks. The term oblong is used more often in education than the term rectangle and students have a big problem correctly recognize models of rectangle. They often choose right-angled triangle or right-angled trapezoid as a rectangle (see Žilková, 2013), because they do not understand that in rectangles are all angles right.



**Figure 3.** The hierarchical relationship between square and rectangle in Slovak national terminology (Medek et al., 1975)

Educational approaches in teaching geometry in Slovakia and Slovak handbooks of mathematics reflect these definitions (even though, term rectangle is not used very often as is described above). From this point of view the difference in results of items 15 and 16 (in both samples) is surprising. Correct response percentage of Slovak students in item 15, which is focused on relationship between square and rectangle, was 93 %. On the other hand correct response percentage of item which tests inverse relationship between both shapes was only 59 %. Hence, Slovak students reliably chose that “square is always a rectangle” but could not reliably identify that “rectangle is sometimes a square”. Up to 41 % of Slovak students chose distractor “rectangle is always a square”. Similar difference was observed in Turkish sample; while only 23 % of the Turkish participants correctly chose the statement “rectangle is sometimes a square”, 63 % of them correctly understand deduction of “square is always a rectangle”. It is obvious that item 16 was more difficult than item 15 for students in the whole sample. Briefly, deduction from bigger set to smaller set related rectangle and square was harder for both group of teacher candidates. As both square and rectangle are very familiar quadrilateral for the participants we assume that participants’ difficulties lied on the logical deduction. This result could mean that teacher candidates do not understand necessary and sufficient condition, they do not distinguish between subset and superset respectively. As the wordings of the questions mattered it is obvious that the linguistics had an important impact on participants’ response.

The picture of square in item 5d was marked by Slovak students as rectangle with the correct response percentage of 87 which is consistent with results in item 15. Items 15 and 5d test the same relationship, the only difference is in the formulation of items. Surprising result arises in comparison

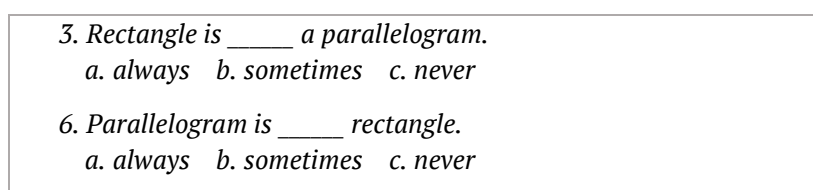
of items 15 and 5d in the sample of Turkish students. Although more than half of the Turkish sample (63 %) supposed that square is always rectangle, only 13% of them selected the alternative of rectangle to describe the given square. This big difference can be understood by interpreting the correct response rate to all alternatives of this question. Despite the fact that all alternatives are correct for this questions, only 1 % of Turkish sample selected all alternatives. The responses accumulated on alternative *a*) (57 %), then *b*), *c*) and *d*) (42 %, 17 %, 13 %, respectively). This can be interpreted as they felt to choose one alternative and majority selected the rhombus which was the first one.

### ***Class inclusion between rectangles and upper class shape***

In this part, findings related with preservice teachers' conceptions of class inclusion between rectangles and two of its upper class shape, namely parallelogram and polygon is displayed in under related titles.

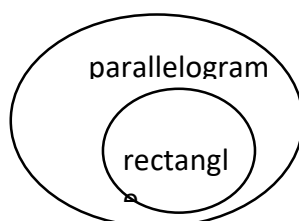
#### *Understanding of class inclusion between rectangles and parallelogram*

Questions 3 and 6 are related with class inclusion between rectangle and parallelogram are as follows.



**Figure 4.** The questions on relationship between rectangle and parallelogram

These two questions have the same pattern as the questions 15 and 16. Questions 3 and 6 examined the preservice teachers' ability of understanding logical deduction between set of rectangles and set of parallelograms. Basically, inclusive relations displayed by Venn diagram in Figure 5 was examined in these questions with different way of relations. Preservice teachers were expected to deduce “a rectangle is always a parallelogram” and “a parallelogram is sometimes a rectangle”.



**Figure 5.** The questions on relationship between rectangle and parallelogram

The correct response percentage and result of chi-square test of independence of Slovak and Turkish samples on these questions are displayed in the Table 2.

**Table 2.** The results related with class inclusion between rectangle and parallelogram

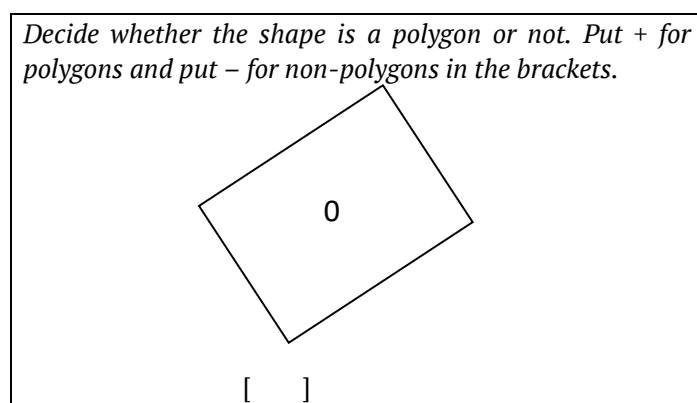
Item	SVK (%)	TUR (%)	$\chi^2(1)$	p
3	49	70	6,267a	,011
6	65	28	13,204a	,009

Despite the fact that both parallelogram and rectangle are defined in both countries in a similar way, Turkish sample got significantly higher score in question 3, but Slovak sample got significantly higher score in question 6 (Table 2). In both country's curriculum parallelogram is defined as the quadrilateral with two pairs of parallel sides and rectangle is defined as parallelogram with four right angles. From the results of Slovak sample we can conclude that item 6 was easier than item 3, hence, 65 % of students chose correctly that parallelogram is sometimes a rectangle. Inverse relationship in item 3 was correctly chosen only by 49 % of Slovak students. Those differences may be caused by multiple reasons, for example, problem with logical deduction or problem with understanding of relationships between

subsets and supersets or difficulties with understanding the meaning of words “always”, “sometimes” and “never” etc. Based on our results we are not able to reliably determine the cause of problems and differences between answers to items 3 and 6. However, based on previous research in Slovakia (Žilková, 2014) another explanation should be considered. Slovak students often understand under the term rectangle not only squares and oblongs but also other shapes with one right angle, e.g. right-angled triangle, right-angled trapezoid (as stated above). If students in Slovak sample had misconception about rectangle and imagined under this term also other shapes with right angle then they could chose second alternative in item 3. Up to 37 % Slovak students chose this alternative. We assume that the misconception about term rectangle caused the difference between success rate of Slovak students in items 3 and 6. It is interesting that sample of Turkish preservice teacher shown different response pattern. It can be said that item 6 was harder than item 3 for Turkish sample. The deduction from bigger set to smaller set related parallelogram and rectangle seemed more difficult for this group. As this findings of Turkish sample was similar with their response patterns related with deduction between square and rectangle, we can conclude that Turkish participants’ difficulties lied on the logical deduction. Briefly, they had problems in make a distinction between subset and superset.

#### *Understanding of class inclusion between rectangles and polygon*

Preservice teachers were given 20 figures and they were instructed to select the polygons. Among those 20 figures one of them was rectangle (Figure 6). We use data related with this question as an evidence of participants’ understanding class inclusion between rectangle and polygon.



**Figure 6.** The questions on relationship between rectangle and polygon

The correct response percentage and result of chi-square test of independence of Slovak and Turkish samples on this question were displayed in the Table 3.

**Table 3.** The results related with class inclusion between rectangle and parallelogram

Item	SVK (n = 84), (%)	TUR (n = 60), (%)	$\chi^2(1)$	p
0	79	95	7,389a	,007

The results of analysis showed that approximately one fifth of Slovak sample did not mark rectangle in the picture as a polygon. After the administration of test we interviewed with preservice teachers and investigated the origin of this perception. From preservice teachers’ answers we found out that they do not perceive triangles and quadrilaterals as polygons. According to them a polygon is a 2D shape, which has “many” vertices and “many” sides. Triangles have only 3 vertices and 3 sides, quadrilaterals have only 4 vertices and 4 sides and that is not many according to preservice teachers. Another reason is that in their prior education the special attention was paid to triangles and quadrilaterals, therefore, they considered these shapes different than other polygons. Because of this we assume that the problem of Slovak students in this item is caused by misunderstanding of term polygon. It is evident that with Turkish sample no big problems with polygon and classification of rectangle to class of polygon.

## Conclusion

The aim of the study was to describe the conceptions Slovak and Turkish preservice teachers have about class inclusions connected with the term rectangle. The results showed that thinking about rectangles, as a subset of square was more difficult for both groups of teacher candidates. As both square and rectangle are well-known quadrilaterals for all participants we assume that reasons for participants' difficulties were the logical deduction or linguistics difficulties with understanding of item's formulations. We observed differences in results between both samples about rectangles and upper class shape. The Turkish sample was better in identification that the set of rectangle is a subset of parallelogram and the results of Slovak sample showed that they are more able to identify parallelogram as a superset of rectangle. The relationship between rectangle and polygon was easier for Turkish sample. We can support that preservice candidates of teachers showed misconceptions about rectangles. Specially, for Slovak sample was the term oblong (as a subset of rectangle, which is not a square) easier than the term rectangle and we think the most of their problems was caused by educational approaches. The conceptions about the term polygon were not so correct for Slovak sample and results showed that we have to suggest educational intervention to refine on better understanding of these two terms (rectangle and polygon). On the other hand the Turkish sample did not have problems with classification of rectangle to higher class, but their results showed problems with perceptions between classes of rectangle and square. Holistically, we can conclude that sample of Slovak and Turkish preservice teachers did not understand class relationships between rectangle and other quadrilaterals (namely squares, parallelograms and polygons) and they showed attributes of second van Hiele level (1986).

These results should be taken by considering some limitations of the study. This study has a convenient sample. It will be recommended that results should be verified on more broad and representative samples. For further research, it would be good to observe the verbal statements of the respondents and their argumentations.

## Acknowledgement

This study was supported by PAU-ADEP 2018KRM002-162(2018KRM002)

## References

- Ball, D. L., Hill, H. C., & Bass, H. (2005, Fall). Knowing Mathematics For Teaching: Who Knows Mathematics Well Enough To Teach Third Grade, And How Can We Decide? *American Educator*, 14–17, 20–22, 43–46.
- Contay, E. G. & Duatepe-Paksu, A. (2012). Preservice Mathematics Teachers' Understandings of the Class Inclusion between Kite and Square. *Procedia – Social and Behavioral Sciences*, 55, 782-788.
- Feza, N. & Webb, P. (2005). Assessment Standards, Van Hiele Levels, and Grade Seven Learners' Understanding of Geometry. *Pythagoras* 62, 36-47.
- Knight, K. C. (2006). *An Investigation into the Change in the Van Hiele Levels of Understanding Geometry of Pre-Service Elementary and Secondary Mathematics Teachers*. (A Thesis), the University of Maine. Retrieved at April 30, 2018, from <https://digitalcommons.library.umaine.edu/etd/1361>
- Marchis, I. (2012). Preservice Primary School Teachers' Elementary Geometry Knowledge. *Acta Didactica Napocensia*, 5(2), 33-40.
- Mason, M. (2002). *The Van Hiele Levels of Geometric Understanding*. Professional Handbook For Teachers, Geometry: Explorations And Applications, Macdougall Litteil Inc. Retrieved at April 30, 2018, from <http://Geometryforall.Yolasite.Com/Resources/Mason,%20marguerite.%20the%20van%20hiele%20levels%20of%20geometric%20understanding.%202002.Pdf>
- Medek, V. et al. (1975). *Mathematical Terminology*. Bratislava, Slovakia: Slovak Academic Publishing.
- Musser, G. L., Burger, W. F. & Peterson, B. E. (2001). *Mathematics for Elementary Teachers*. (5th Edition). New York, USA: John Wiley & Sons.
- Shulman, L. S. (1986). Those Who Understand: Knowledge Growth with Teaching. *Educational Researcher*, 15(2), 4-14.

Turkish and Slovak Preservice Elementary Teachers Comprehend Class Inclusion Related to Rectangle

- Usiskin, Z. (1982). *Van Hiele Levels and Achievement in Secondary School Geometry*. CDASSG Project. Chicago, Us: The University Of Chicago.
- Van Hiele, P. M. (1986). *Structure and Insight: A Theory of Mathematics Education*. Orlando, Fl: Academic Press.
- Van Hiele, P. M. (1999). Developing Geometric Thinking Through Activities That Begin With Play. *Teaching Children Mathematics*, 5(6), 310-317.
- Žilková, K. (2014). Parallelogram Conceptions And Misconceptions Of Students Who Study To Become Teachers In Pre-Primary And Primary Education. *Indian Journal of Applied Research* 4(7), 128-130.
- Žilková, K. (2011). Convex Quadrilaterals and Their Properties in the Training of Teachers for Primary Education. *Acta Didactica Universitatis Comenianae – Mathematics* 11, 73-84.
- Žilková, K. (2013). *Theory and Practice of Geometric Manipulations in Primary Education*. Prague, Czech Republic: Powerprint.





# Preservice Teachers' Perceptions of Plagiarism: A Metaphor-Based Analysis

Yasemin Abali Ozturk, Mehmet Kaan Demir, Cavus Sahin

## 1. Introduction

In Turkey, colleges of education assume the duty of teacher training. They fulfill this mission by training undergraduate students in colleges of education and by offering teaching certificate programs to graduates of other colleges. This training process builds on the acquisition of content knowledge and skills, knowledge and skills of teaching as a profession, and courses on world knowledge. There are various values preservice teachers are expected to acquire during the training process. Academic integrity is among these values. According to Unal and Ozenc Ucak (2017), it is mandatory and crucial to help students acquire research skills and ethical principles as from the very moment of the training. These characteristics gained during teacher training are needed in professional life as well. Undergraduate education is not only a process in which the highest amount of research is conducted but also which helps students prepare for the professional life. Therefore, undergraduates are expected to observe academic integrity principles. Considering that it is very difficult and unethical at older ages to change habits which have been developed in relation to knowledge behaviors, it can be well appreciated that research skills and awareness of academic ethics should be acquired at early ages.

## 2. Literature Review

Academic fraud has gradually become a hotly debated issue across the world over the last years in particular. Plagiarism is the most common unethical behavior, which is likely to occur at any academic level. It is especially known that the proliferation of the internet and facilitated access to and sharing of information enhanced the cases of unethical information exploitation (Unal & Ozenc Ucak, 2017). The world has witnessed a rapid technological revolution over the last quarter of the 21st century. The creation and distribution of information have been unprecedentedly fast and incomparable to the previous centuries. This has affected not only the scholars of the present time but also of the future. Copy-and-paste and cut-and-paste have become regular practices in the activities performed by preservice teachers during their pre-service training. The importance of the awareness of plagiarism should be highlighted during this process. Of course, as the use of internet increases all over the world, so do the cases of plagiarism, but it should be known that this technological advancement has also made the detection of plagiarism easier.

Plagiarism is referred to as the behavior of copying or copy-pasting the materials found online or in other works to use or insert them in an academic work (Ersoy & Ozden, 2011). It also denotes the presentation of lines and parts from others' works as one's own or adapting others' subjects to present them in a very different way (Turk Dil Kurumu, 2017). It means the act of deliberately presenting others' knowledge and skills as one's own (Pavela, 1997). As Cakmak (2015) states, plagiarism is as an old academic phenomenon as science itself. It is defined on plagiarism.org as "turning in someone else's work as your own, copying words or ideas from someone else without giving credit, failing to put a quotation in quotation marks, giving incorrect information about the source of a quotation, changing words but copying the sentence structure of a source without giving credit, and copying so many words or ideas from a source that it makes up the majority of your work, whether you give credit or not".

Students plagiarize intentionally and unintentionally. As Cakmak (2015) cites from various sources, intentional plagiarism is an conscious act and it occurs when students choose the easy way out, are concerned with scores or wish to get higher marks, suffer from time pressure or fail to manage time, are unwilling to conduct comprehensive research (out of laziness), and study at a university where ethical principles are not strictly observed or they are not educated on academic integrity. On the other side, unintentional plagiarism results from students' lack of knowledge. Leask (2006) highlights the

difficulty of understanding the issue students from different educational and cultural background experience. It is believed by the Western academic milieu that “culturally inferior others who must be taught how to learn other than by rote and imitation, whose learning style and strategies impede critical thinking and are likely to result in inadvertent plagiarism” (Leask, 2006: 185).

A research study over Turkish students has revealed that students mostly plagiarize due to lack of awareness and of researching knowledge and skills (Erkaya, 2009). In the report on unethical behaviors in academic settings, which was issued by the Turkish Academy of Sciences (2002), the causes of plagiarism are categorized into four groups and the first of these causes is lack of education (Arslan, and Rata, 2015).

Mahmood (2009), claiming based on research conducted in the USA and Western Europe that students’ cultural differences are influential in their perceptions of plagiarism and international students in particular do not bother to feel concerned about copying others’ materials, states that students cannot appreciate the difference between paraphrasing and copying and have difficulty citing properly (cited in Unal & Ozenc Ucak, 2017).

The results of the research by Razek (2014) over 673 undergraduate students in Saudi Arabia are striking for they reveal the contradiction between faith and behaviors because students confess that they plagiarize and copy even if they think that these two acts defy religious, ethical, and cultural values (cited in Unal & Ozenc Ucak, 2017).

Another case of perception of plagiarism and the associated lack of education is a study on Turkish undergraduate students. The research has revealed that copying and assignment exchange are common practices among students and students see no harm sharing their homework with other students and their friends’ turning it in as their own. The findings have showed that 27.5% of the students do not consider plagiarism as an academic misconduct and 47.5% think that copied assignments cannot be construed as plagiarism (Kose & Arikan, 2011). Orhan and Gunay (2014), suggesting that root learning-based education and assignment of non-analytical tasks are effective in the excessive prevalence of copy-pasting, express that assigning the same tasks every year give way to the act of copying homework of the past years.

It has been found that preservice elementary school teachers use online source in 94% of their assignments, 13% of which include plagiarism (Ersoy & Karaduman, 2010). In a qualitative study, Ersoy (2014) has revealed the views of preservice elementary school teachers about their experience of plagiarizing in research reports of a certain course. The participants have explained their motives by associating the causes of plagiarism with personal traits, peer relations, role of the lecturer, technology use culture and role of the course. Lack of research skills and delaying assignments till the last moment are listed among the examples of personal traits. The fact that senior classes advise them to benefit from the internet can be considered as a sort of plagiarism caused by peer relations. The perception that lecturer does marking without even reading the papers is another likely cause of plagiarism. Delaying assignments till the last minute and resorting to technology as “the last bastion” is also listed among the motives to plagiarize. Plagiarism performed owing to the role of the course arises from underrating the class.

Research studies on copying/plagiarism in Turkey have been conducted based on colleges, departments, and programs at universities. For example, among the studies are the research on students of College of Theology (Kaymakcan, 2002), of College of Economics and Administrative Sciences (Arslantas & Acar, 2008), of Elementary School Education (Ersoy & Karaduman, 2010; Ersoy & Ozden, 2011), of Elementary School Mathematics Education (Eraslan, 2011), of non-thesis MA program (Durmuscelebi, 2011), preservice elementary school teachers (Ersoy, 2014) and on conceptual misconceptions concerning unintentional plagiarism committed by undergraduate students (Cakmak, 2015) and on views and thoughts of undergraduate students from similar departments in two different countries on plagiarism and copying (Unal & Ozenc Ucak, 2017).

Motivating preservice teachers to acquire the competencies of teaching profession such as keeping up-to-date with educational innovations and translating these developments into classrooms and adopting life-long learning as a philosophy of life (Korkmaz, Kucuk & Karabacak, 2016) are among the

major gains offered by preservice training Preservice teachers should be supported to appreciate that plagiarism, also referred to academic fraud and academic theft, is an unethical and undesirable behavior while desirable behaviors to be expected from preservice teachers for the development of these professional values are to follow scientific advancements, to acquire research competence and so on. A great number of previous studies have emphasized that preservice teachers' underdeveloped awareness of plagiarism and persistence of this approach of such a nature are influential in the occurrence of such behaviors even in their teaching and academic practices and in their lenience towards behaviors contradicting integrity principles and have underlined the importance of perceptions pertaining to plagiarism (Cakmak, 2015; Ersoy, 2014; Firmin, Burger & Blosser, 2009; Nonis & Swift, 2001; Rujoiu & Rujoiu, 2014; Unal & Ozenc Ucak, 2017).

The purpose of the present study is to identify the metaphors originating from plagiarism-oriented perceptions of preservice elementary school teachers having received preservice training.

### 3. Method

This research is a qualitative case study conducted over a sample of 119 sophomore preservice elementary school teachers having taken "Scientific Research Methods" course at a state university in the spring semester of the 2016-2017 academic year.

They were delivered forms containing statements "*Plagiarism is like..... because.....*" and asked to fill in the forms with a specific focus on a metaphor. The content analysis revealed such metaphorical clusters as (1) coding and eliminating, (2) naming, (3) categorizing, and (4) achieving validity and reliability.

In the coding and eliminating phase, metaphors produced by the participants were listed and encoded. The forms obtained from 131 participants were analyzed in this process and the forms without metaphors but explanations/definitions (7 forms), without no explanation concerning metaphors (3 forms), and with no response (2 forms) were eliminated in view of whether the participant distinctly produces a metaphor.

In naming metaphors (categorization), categories were formed based on the common features of the metaphors identified in the participants' responses. Metaphors were grouped according to their semantic bases and thematic associations and sub-categories were created in consideration of the similarities between metaphors.

Categorization/thematization was also built on shared characteristics. These sub-categories were merged into certain themes. Thusly, the sub-categories and themes based on these sub-categories were organized and analyzed. The obtained themes are "professional misconduct", "labor exploitation", "laziness" and "self-deception".

In the step "achieving reliability", the metaphorical images in the 4 conceptual categories obtained in the research were submitted to an expert to ensure that they represent the respective conceptual categories. To this end, an expert of the field was provided with an alphabetically ordered list of the 44 sample metaphorical images and with the titles and characteristics of the 4 conceptual categories. The expert was asked to use both lists to categorize the sample metaphorical images on list 1 into the 4 conceptual categories on list 2. Then, the expert's matching was compared with the researchers' own. "Agreed" and "disagreed" items were identified in the comparison and the reliability was calculated based on Miles and Huberman's (1994: 64) formula " $\text{reliability} = \frac{\text{number of agreements}}{(\text{total number of agreements} + \text{disagreements})} \times 100$ ". The expert put only six metaphors ("evil step mother", "boss", "stuck to dreams", "wig", "gambling", and "exchanging exam paper") in a category different from the categorization by the researchers. The reliability was calculated to be %86 ( $\frac{38}{38+6} \times 100$ ), which suggests that the tool is reliable because the calculated value is over 70%.

For the purpose of the study, the male participants were encoded as M1, M2, M3... and the female participants as F1, F2, F3... .

#### 4. Findings

The metaphors produced by 119 preservice elementary school teachers in relation to plagiarism are presented in Table 1.

**Table 1.** Valid metaphors produced by preservice elementary school teachers concerning plagiarism and the related frequencies and percentages

Metaphors	f	%	Metaphors	f	%
Thief/theft	49	41.2	Evil step mother	1	0.8
Copying	15	12.6	Boss	1	0.8
Piracy	7	5.9	Fake invoice	1	0.8
Illegal electricity use	3	2.5	Fanciful heroism	1	0.8
Moon	3	2.5	Mask	1	0.8
Baby	2	1.7	Exchanging exam papers	1	0.8
Swamp	2	1.7	Mirror of ignorance	1	0.8
Star	2	1.7	Raping	1	0.8
Painting by an artist	1	0.8	Stuck to dreams	1	0.8
Vulture	1	0.8	Scar	1	0.8
Kamikaze	1	0.8	Well	1	0.8
Junk dealing	1	0.8	Wig	1	0.8
Tumbling on someone else's rope	1	0.8	Lacking ideas	1	0.8
Murder	1	0.8	Mushroom	1	0.8
Drama	1	0.8	Playing blind	1	0.8
A little child	1	0.8	Fire	1	0.8
Bookworm	1	0.8	A little child acting like adults	1	0.8
Corruption	1	0.8	Organ mafia	1	0.8
Parasitism	1	0.8	Cruelty	1	0.8
External hard drive	1	0.8	Gambling	1	0.8
Plastic flower	1	0.8	Serial murder	1	0.8
Adultery	1	0.8	Plague	1	0.8

Table 1 shows that the preservice elementary school teachers produced 44 different metaphors of plagiarism. The most frequently used metaphor by the participants is "theft" (41.2%), followed by "copying" (12.6%), "piracy" (5.9%), "illegal electricity use" and "moon" (2.5%), and "baby", "swamp", and "star" (1.7%).

In the categorization/thematization, the metaphors of plagiarism by the preservice elementary school teachers were further categorized into 4 themes, e.g. professional misconduct, labor exploitation, laziness, and self-deception.

The metaphors of "professional misconduct" are given in Table 2.

## Preservice Teachers' Perceptions of Plagiarism

**Table 2.** The preservice elementary school teachers' plagiarism metaphors of "professional misconduct"

Theme	Metaphors	f
<b>Professional misconduct</b>	Thief	49
	Copying	15
	Piracy	7
	Illegal electricity use	3
	Corruption	1
	Adultery	1
	Evil step mother	1
	Exchanging exam papers	1
	Raping	1
	Organ mafia	1
	Serial murder	1
<b>Total</b>	<b>81</b>	

Table 2 indicates that 11 metaphors of plagiarism produced by 81 preservice elementary school teachers, accounting for 68% of the sample, are located in the category of "professional misconduct". The following are some of the metaphors in the theme of professional misconduct:

*F8: Plagiarism is like serial murder because serial killers plan and act systematically just like plagiarizers planned and sneaky.*

*F25: Plagiarism is like organ mafia because they deceive to steal and then sell organs as if they were their own.*

*M3: Plagiarism is like illegal electricity use because they think that they profit from it, but eventually they get caught and put in prison.*

*F2: Plagiarism is like raping because rapers attack and then claim that the victim belongs to them.*

*F80: Plagiarism is like theft because plagiarizers use others' works, which might have taken years to produce as if their own just as thieves steal someone else's bag, wallet, money and use them as if they were theirs.*

The metaphors concerning "labor exploitation" of plagiarism-related metaphors by preservice elementary school teachers are provided in Table 3.

**Table 3.** The preservice elementary school teachers' plagiarism metaphors of "labor exploitation"

Theme	Metaphors	f
<b>Labor Exploitation</b>	<i>Moon</i>	3
	<i>Star</i>	2
	<i>Painting by An Artist</i>	1
	<i>Kamikaze</i>	1
	<i>Junk dealing</i>	1
	<i>Tumbling on someone else's rope</i>	1
	<i>Murder</i>	1
	<i>Drama</i>	1
	<i>External hard drive</i>	1
	<i>Boss</i>	1
	<i>Mask</i>	1
	<i>Cruelty</i>	1
	<b>Total</b>	<b>15</b>

Table 3 indicates that 12 metaphors of plagiarism produced by 15 preservice elementary school teachers, accounting for 13% of the sample, are located in the category of “Labor Exploitation”. The following are some of the metaphors in the theme of “labor exploitation”:

*F14: Plagiarism is like a painting by an artist because artists inspire from some things, some people. Moreover, they even use it as it is. However, they do not obtain permission from or inform owners, and benefit from the beauties of someone else’s work without bothering to inform them. In other words, they exploit the labor put in for the creation of other beauties and present it as their own.*

*F18: Plagiarism is like a star because stars become visible thanks to the light they receive from the sun. Plagiarizers make themselves visible with somebody else’s knowledge.*

*M12: Plagiarism is like drama because dramatic descriptions include imitations and pretending. Plagiarizers too imitate someone else’s work and act as if it was their own.*

*M21: Plagiarism is like an external hard drive because data on an external hard drive do not exactly belong to a computer and similarly plagiarism is like carrying data that do not belong to you.*

*F90: Plagiarism is like a boss because all work in a business is performed by employees who eventually come up with a product. Then, the product is labeled with the boss’s name and introduced into the market with the same name on it. But the product has been produced by the employees but not the boss. Likewise, plagiarizers present someone else’s work as their own.*

*F7: Plagiarism is like a mask because plagiarizers use someone else’s face to present others’ work as their own.*

*M12: Plagiarism is like the moon because it deceives everyone, but it only reflects the light from the sun.* The metaphors concerning “laziness” of plagiarism-related metaphors by preservice elementary school teachers are provided in Table 4.

**Table 4.** The preservice elementary school teachers’ plagiarism metaphors of “laziness”

Theme	Metaphors	Frequency (f)
Laziness	Baby	2
	Vulture	1
	A little child	1
	Bookworm	1
	Parasitism	1
	Fake invoice	1
	Fanciful heroism	1
	Lack of ideas	1
	Mushroom	1
	A little child acting like adults	1
	Gambling	1
	<b>Total</b>	<b>12</b>

Table 4 indicates that 11 metaphors of plagiarism produced by 12 preservice elementary school teachers, accounting for 10% of the sample, are located in the category of “laziness”. The following are some of the metaphors in the theme of “laziness”:

*F70: Plagiarism is like gambling because plagiarizers earn from other people without making any effort.*

*F54: Plagiarism is like a mushroom because mushrooms parasitically live on thanks to other plants and they like the easy way.*

*F33: Plagiarism is like fanciful heroism because plagiarizers fancy that others’ works are as if their own and they do not strive to become heroes. They just act like dreamers nothing to do with heroism and seeking the easy way to become famous.*

The metaphors concerning “self-deception” of plagiarism-related metaphors by preservice elementary school teachers are provided in Table 5.

## Preservice Teachers' Perceptions of Plagiarism

**Table 5.** The preservice elementary school teachers' plagiarism metaphors of "self-deception"

Theme	Metaphors	Frequency (f)
Self-deception	Plastic flower	1
	Mirror of ignorance	1
	Stuck to dreams	1
	Scar	1
	Wig	1
	Playing blind	1
	Fire	1
<b>Total</b>		<b>7</b>

Table 5 shows that 7 metaphors of plagiarism produced by 7 preservice elementary school teachers, accounting for 6% of the sample, are located in the category of "Self-deception". The following are some of the metaphors in the theme of "self-deception":

*F70: Plagiarism is like being stuck to dreams because plagiarizers want it to be theirs, dream and think that it is theirs. Everybody but you knows that it does not belong to you, yet only they enjoy this false achievement and linger around with meaningless pride.*

*F33: Plagiarism is like a wig because even though its actual owner is not known, it carries a part of its owner with itself. Much as wig wearers act as if the false hair was their own and believe so deep within their souls, it is for vain and blatantly obvious that it is someone else's.*

*M17: Plagiarism is like fire. If plagiarizers try to snatch it from someone else's hand, they get burnt and it leaves a mark.*

## 5. Conclusion

This metaphor-based analysis conducted over 119 preservice elementary school teachers at a state university revealed 44 different metaphor produced by the participants. In consideration of these metaphors, it can be realized that the most frequently used metaphor by the participants is "theft" (41.2%), followed by "copying" (12.6%), "piracy" (5.9%), "illegal electricity use" and "moon" (2.5%), and "baby", "swamp", and "star" (1.7%).

Lofstrom (2011) too reported that students drew parallels between plagiarism and theft. While the students experienced less ambiguity about the concept of theft, plagiarism as a concept was not so clear (cited in Cakmak, 2015).

The metaphors of plagiarism by the preservice elementary school teachers were further categorized into 4 themes, e.g. professional misconduct, labor exploitation, laziness, and self-deception: It was observed that

- 11 metaphors of plagiarism produced by 81 preservice elementary school teachers, accounting for 68% of the sample, are located in the category of "professional misconduct".
- 12 metaphors of plagiarism produced by 15 preservice elementary school teachers, accounting for 13% of the sample, are located in the category of "labor exploitation".
- 11 metaphors of plagiarism produced by 12 preservice elementary school teachers, accounting for 10% of the sample, are located in the category of "laziness".
- 7 metaphors of plagiarism produced by 7 preservice elementary school teachers, accounting for 6% of the sample, are located in the category of "self-deception".

Gullifer and Tyson (2010) investigated 41 students' perceptions of plagiarism in the form of a group work at a local university in Australia. They found that the students felt confused about what behaviors should be labeled as plagiarism other than verbatim copying of a textual unit without providing references. The following statement of the participants in this group is striking to highlight their lack of knowledge on plagiarism: "Not fully understanding what plagiarism is, what are the different areas of plagiarism, and, therefore, they'll do it inadvertently, just because they don't understand what plagiarism is" (Gullifer & Tyson, 2010: 470).



In the study by Unal and Ozenc Ucak (2017), in response to the question “When was the first time they heard about the concept of plagiarism?”, 49%, 23%, 16%, and 10% of their participants expressed that they first heard about plagiarism when they were at university, middle school, high school, and elementary school, respectively. To the question “When was the first time they received an education as to how research should be conducted?”, 48% replied that it was at university, while 25% and 18% stated that they were offered an education about this issue at middle school and high school, respectively. Moreover, it was also reported that 84% always and 14% sometimes referenced the works they benefited from in their assignments. To the question whether they question the reliability and validity of the information they retrieved, 52% and 45% replied “always” and “sometimes”, respectively. Generally, 72% of the student thought that their lack of knowledge as to what plagiarism is and involves is likely to result in plagiarism. It was observed taking all the participants into account that a high number of students (76%) believed that not knowing the rules and standards concerning referencing and references organization would lead to plagiarism. The obtained results demonstrated that 72% of the students thought that their motive to pass a course and to be successful potentially results in plagiarism. The percentage associated with the ones of the opinion that lecturers’ failure to provide feedback and their not being able to see their mistakes negatively contribute to the occurrence of plagiarism was 42%.

By presenting the results of research studies majorly on faculty members, Avarogullari (2012) claims that plagiarism which is a confusing concept even for academicians and is not clearly understood by them is far more complicated for students, who do not know how to avoid plagiarism. The study by Nonis and Swift (2001) evidenced that unethical behaviors students developed during their education processes tended to persist even in their professional lives. Rujoiu and Rujoiu (2014) state that the habit of exhibiting unethical behaviors does harm to labor peace, productivity, and social structure. By putting the emphasis on the shortcomings in terms of research education in educational system, Sahin and Altinay (2009) highlight that this phenomenon cause problems in higher education and a great many students do not know what the research steps are, how to do research, how to report the retrieved information after internalized, and how to reference.

Unal and Ozenc Ucak (2017) indicate that individuals should be educated and helped gain awareness of academic integrity and enforcements should be deterrent to stop plagiarism and copying in almost all studies. In the project “Impact of Policies for Plagiarism in Higher Education Across Europe”, supported by the European Union (EU), research was conducted in 27 countries. The obtained results revealed that most of the 27 countries failed to develop competent policies and to enforce effective implementations to identify and prevent academic misconduct and plagiarism at higher education institutions (Impact of Policies for Plagiarism in Higher Education Across Europe, 2013).

## 6. References

- Arslan, H. and Rata, G. (2015). *Interdisciplinary Perspectives on Social Science*. London: Cambridge Scholars Publishing.
- Arslantas C., & Acar, G. (2008). Son sınıf ogrencilerinin akademik yasamdaki ve is hayatindaki sahtekarliga iliskin algilamalari. *Yonetim*, 19(60), 32-47.
- Avarogullari, M. (2012). *Sosyal bilgiler ogretmen adaylarinin ve ogretim elemanlarinin intihal problemine yonelik tutum ve davranislari*. (Yayimlanmamis doktora tezi). Gazi Universitesi Egitim Bilimleri Enstitusu, Ankara.
- Cakmak, N. (2015). Undergraduates’ Misconceptions Concerning Plagiarism. *Turk Kutuphaneciligi*, 29(2), 212-240.
- Durmuscelebi, M. (2011). Lise ogrencilerinin ve ogretim adaylarinin kopya cekme davranislarina iliskin gorusleri. *Kuram ve Uygulamada Egitim Yonetimi*, 17(1), 77-97.
- Eraslan, A. (2011). Matematik ogretmeni adaylari ve kopya: Hic cekmedim desem yalan olur. *Egitim ve Bilim*, 36(160), 52-64.
- Erkaya, O. R. (2009). Plagiarism by Turkish students: Causes and solutions. *Asian EFL Journal*, 11(2), 86-103.

- Ersoy, A., & Karaduman, H. (2010). Sinif ogretmeni adaylarinin hazirladiklari arastirma raporlarinda dijital asirma: Google arama motoru ornegi. *Ulusal Sinif Ogretmenligi Egitimi Sempozyumu Tam Metinler icinde* (s. 529-534). Ankara: Cantekin Matbaasi.
- Ersoy, A., & Ozden, M. (2011). Ogretmen adaylarinin odevlerinde internetten intihal yapmalarinda ogretim elemaninin rolune iliskin gorusleri. *Ilkogretim Online*, 10(2), 608-619. [Online] <http://ilkogretim-online.org.tr>
- Ersoy, A. (2014). I was not aware I plagiarized from online resources: A Phenomenological Research. *Pamukkale Universitesi Egitim Fakultesi Dergisi*, 35(1), 47-60.
- Firmin, M., Burger, A., & Blosser, M. (2009). Affective responses of students who witness classroom cheating. *Educational Research Quarterly*, 32, 3-15.
- Gullifer, J., & Tyson, G. A. (2010). Exploring university students' perceptions of plagiarism: a focus group study. *Studies in Higher Education*, 35 (4), 463-481.
- Kaymakcan, R. (2002). Ilahiyat ogrencilerinin kopya cekmeye karsi yaklasimlari. *Sakarya Universitesi Ilahiyat Fakultesi Dergisi*, 5, 121-138.
- Korkmaz, I., Kucuk, M., & Karabacak (2016). Degerler Bilancosu: Sosyoloji, Felsefe, Ekonomi, Egitim, Iletisim, Muzik, Tip, H.H. Bircan & B. Dilmac (Ed.) *Turk Egitim Sistemindeki Ogretmenlik Mesleginin Mesleki Degerlerine Dogru Bir Sentez* (219-249). Konya: Cizgi Kitabevi.
- Kose, O., & Arikan, A. (2011). Reducing plagiarism by using online software: An experimental study. *Contemporary Online Language Education Journal*, 1, 122-129.
- Miles, M. B. & Huberman A.M (1994). *Qualitative Data Analysis : An Expanded Sourcebook*. (2nd Edition). Calif.: Sage Publications.
- Leask, B. (2006). Plagiarism, cultural diversity and metaphor-implications for academic staff development. *Assessment & Evaluation in Higher Education*, 31(2), 183-199.
- Nonis, S., & Swift, C. O. (2001). An examination of the relationship between academic dishonesty and workplace dishonesty: A multicampus investigation. *Journal of Education for Business*, 77(2), 69-77.
- Orhan, F., & Gunay, A. (2014). Universite ogrencilerinin internet tabanlı akademik usulsuzluk nedenlerinin cesitli degiskenlere gore incelenmesi. *Ege Egitim Dergisi*, 15(1), 176-190.
- Pavela, G. (1997). Applying the power of association on campus: A model code of academic integrity. *Journal of College and University Law*, 24, 97-118.
- Rujoiu, O., & Rujoiu, V. (2014). Academic dishonesty and workplace dishonesty. An overview. Proceedings of the 8th International Management Conference "Management Challenges for Sustainable Development", November 6th-7th, 2014, Bucharest, Romania. (<http://conferinta.management.ase.ro/archives/2014/pdf/91.pdf>)
- Sahin, C., & Altınay, Y. B. (2009). Ilkogretim 1. kademedeki ogrencilerin dusunme becerilerini ve yaraticiliklerini gelistirmek amaciyla aktif arastirmaci olarak arastirma tekniklerini kullanma becerilerinin degerlendirilmesi. *In Proceedings of the The First International Congress of Educational Research*, 1-3 May 2009.
- Turkish Academy of Sciences (TUBA) (2002). *Bilimsel arastirmalarda etik ve sorunlar*. [ftp://ftp.sdu.edu.tr/pub/mat/serpil/BATE/TUBA\\_2002.pdf](ftp://ftp.sdu.edu.tr/pub/mat/serpil/BATE/TUBA_2002.pdf)
- Turk Dil Kurumu. (t.y). *Buyuk Turkce Sozluk*, <http://tdkterim.gov.tr/bts/?kategori>
- Unal, Y., & OzencUcak, N. (2017). Views and behaviors of university students from different educational and cultural settings towards plagiarism. *Journal of Faculty of Letters*, 34(1), 177-194.



# Investigating Pre-service EFL Teachers' Perceptions of Teacher Qualities in the Context of Teacher Training

Cevdet Yilmaz

## 1. Introduction

Education takes as its primary goal the provision of quality in educational system by the institutions involved. The efforts to increase the quality of the educational system necessitate comprehensive reforms in teacher education (Saglam & Kurum, 2005). This means that the prerequisite for the quality in education is the qualified teacher (Adiguzel, 2005). That is to say, the components of teachers and their qualities both of which make up the educational system come to the forefront (Cakmak, 2009; Adiguzel, 2005, Bikmaz ve Guler, 2002).

The concepts of “teacher quality” and “effective teacher” have drawn attention of many researchers in all the educational fields including foreign language teaching. Related literature shows that there has been an extensive research (Miller, 1992; Yates, 2005; Ansari and Malik, 2013) on the features of effective teaching, focusing, in particular, on the characteristics of effective teachers. The underlying idea is that the prerequisite for the teaching is the qualified teacher (Adiguzel, 2005).

Most of the studies conducted in the field of language teaching aimed to highlight some specific characteristics of language teachers. Related literature shows that a number of researchers (Brosh 1996; Brown 2009; Kelly 2007) have identified the characteristics of effective teachers. To illustrate, Anderson (1991) defined an effective language teacher as someone who guides their students alongside their learning process directly or indirectly. Bulger, Mohr and Walls (2002) pointed out that “a teacher's ultimate responsibility is to facilitate learning which highlights teacher's role as a facilitator”. Sutkin, Wagner, Harris and Schiffer (2008) maintained that the features of the most effective teachers are “recognition of relationship, generating responsibility and having self-awareness and competence”. Notably, these features of effective teachers are mostly universal, but others are field-specific (Badawood, 2015).

Various classifications have been made as to the characteristics with which teachers should be equipped in the process of teacher training. The teacher should have in general qualifications; personal, field and educational competencies (Caliskan, Isik & Saygin, 2013). They posit that personal competence reflects high personal responsibility, creativity, ability to solve problems, critical thinking, team work, understanding, compassion and tolerance (Caliskan, Isik & Saygin, 2013). With regard to the field competence, the quality and quantity of the relevant professional knowledge in a particular subject area is required. Educational competence relies on the teacher's educational study, in particular, the teaching itself (Sunbul, 2006). At this point, the whole stakeholders acknowledge that a qualified teacher should possess both educational and field competence. In addition to these, personal competence is of particular importance to the teacher quality, which enables them to be tolerant, caring, insightful, humorous, open-minded, encouraging, supporter, and so on. In a study undertaken by Shermen and Blacman (1975), 1500 university students were asked to evaluate their teachers' performance in the classroom. Based on the emerging data, they drew the conclusion that the teacher's personality matters rather than methods or in-class activities.

A considerable body of research on the concept of effective teacher has been conducted in the field of foreign language teaching. Research has shown that it is crucial to improve the qualities of EFL teachers in order to improve students' attitudes and motivations to language learning (Zamani & Ahangari, 2016). This consideration guided the research by Zamani and Ahangari (2016) who aimed to characterize the defining qualities of an effective English language teacher in Iranian EFL context. For this purpose, a questionnaire was administered to English language learners, and the results showed that students expected a good English teacher to have the ability to communicate with students and

the ability to build students' confidence, and to be able to maintain discipline in the classroom. Wichadee (2010) conducted a similar study aimed at exploring the characteristics of effective English teachers as perceived by students and teachers at Bangkok University in Thailand. Four themes emerged from the data: English proficiency, pedagogical knowledge, organization and communication skills, and socio-affective skills. The data were obtained by means of a questionnaire and the findings indicated that all of the characteristics were generally found to be important by students, with the highest ranking given to organization and communication skills.

There has been limited research on the qualities of effective foreign language teacher in Turkish context. A collaborative study by Arikan, Taser, Sarac and Sezer (2008) was intended to shed light on the characteristics of effective language teachers in Turkey. Their study showed that there were a variety of qualities ascribed to an effective foreign language teacher. As the results revealed, an effective teacher was considered to be a friendly, young, enthusiastic, creative, and humorous person. In addition, the participants held the view that an effective English teacher was the one who could incorporate games into their teaching and make use of group/pair work activities when attempting to individualize the teaching tasks during the class. In a current study (Cakmak & Gunduz, 2018) the quality of effective teachers were examined from pre-service ELT teachers' point of view. Data were collected through mixed-methods research in the study. There were 192 participants in this study from the Department of English Language Teaching in two state universities in Turkey. The study concluded that being objective, competent and consistent were the most important characteristics of effective teachers. The qualitative data also pointed to the importance of creating positive learning environment, getting prepared for lessons and managing classroom.

Research indicates that pre-service teachers can contribute to their professional development based on personal experiences of teaching (Ridgeway & Bowyer, 1998). However, very few studies have actually focused on the views of pre-service teachers about what they believe good teachers to be, what they think they need to know (Jegeda, Taplin & Chan, 2000). If teacher education is to meet the educational needs of pre-service teachers, understanding pre-service teachers' conceptions of good teaching is crucial because prior understanding of their views informs the development of their learning. Studies confirm that pre-service teachers are consistently constructing new views of good teaching based on their personal experiences (Sheridan, 2011). Further, Sheridan (2011) suggests that teacher education programs can better address alternative conceptions through understanding the perceptions of pre-service teachers.

Based on the existing literature on the qualities of teachers, the present study intends to contribute to the development of teacher education by exploring student teachers' perceptions of the teaching profession, as the perceptions can be indicative of the learning needs of student teachers in their education. More specifically, pertinent to this aim is to demonstrate that student teachers' perceptions of the teaching profession may be the first step in the development of their identity as prospective teacher (Bergmark, Lundstrom & Palo, 2018). The aim of the study is to identify teacher trainees' perceptions of the qualities of effective English language teachers. The following research question is addressed in the study:

- How do pre-service EFL teachers perceive the characteristics of an effective teacher, based on their prior experiences of education?

## 2. Method

This study intends to identify the defining characteristics of effective EFL teachers from pre-service EFL teachers' perspectives in Turkish context. In the phase of data analysis, the phenomenological approach of qualitative research design was used (Patton, 2002). This design allowed the researcher to tap into the experiences from the perspective of the pre-service EFL teachers and in turn to maximize the depth of the information collected.

### Participants

Participants were fourth year pre-service teachers (n=14) who took the practicum course in the Department of English Language Teaching at Canakkale Onsekiz Mart University, Turkey in 2017-2018 academic year. The participants were purposefully selected through convenience sampling method (Fraenkel, Wallen & Hyun, 2014). This method proves useful to researchers since it provides an easy and simple access to the participants (Patton, 2015).

### Data Collection Tool

The data sources employed in this study comprised semi-structured interview forms developed by the researcher. For this purpose, 14 teacher trainees were interviewed when the process of teaching practice was completed. Individual interviews were carried out with the student teachers in a semi-structured manner, which in turn allowed for in-depth analysis of the participants' perceptions. As Turner (2010) pointed out, preparing effective research questions for the interview process is one of the most important components in designing interview. Likewise, it has turned out that semi-structured interviews also allow for the systematic analysis of the data collected (Yildirim & Simsek, 2006). During the interview process, the research question generated in line with the purposes of the study was directed to student teachers as follows:

- What are the most important qualities of an effective English language teacher in your opinion?

### Data Analysis

The qualitative data were analyzed employing content analysis (Strauss & Corbin, 2008). After the transcription of the emerging data, the content analysis was applied in four stages: 1) coding of the data, 2) identification of the themes, 3) arrangement of the themes, and 4) description and interpretation of the findings. After all transcriptions and codes were determined, the codes from informants were reviewed, and common patterns were supplied. Data were systematized by the themes, for instance, Theme 1: Professional Development, Theme 2: Teaching and Learning Process, Theme 3: Classroom Management and Theme 4: Focus on Learner Needs.

### 3. Findings and Discussion

The data revealed four common themes: 1) Professional development, 2) Teaching and learning process, 3) Classroom management, 4) Focus on learner needs.

#### Professional Development

Professional development is defined as the total sum of formal and informal learning experiences throughout a teacher's career (Goh and Loh, 2013). As the results of the study revealed, pre-service teachers reported several factors in connection with the professional development of teachers. Among these factors the cognitive aspects were of considerable importance to the pre-service teachers. This is underlined in the following extract:

An EFL teacher should possess the ability to acquire both his native language as well as the target language, and should keep up with the recent developments in the field of SLA (Second Language Acquisition). An ideal teacher should also develop innovative ways of transmitting knowledge for students to apply in different contexts.

As Avalos (2011, p. 10) points out, professional development involves 'teachers learning, learning how to learn, transforming their knowledge into practice for the benefit of their students' growth'. The process requires both cognitive and emotional involvement, as well as a willingness to examine where one stands (Hargreaves 2000, Rodgers and Raider-Roth 2006).

In addition to cognitive aspects, many of the participants emphasized the relevance of emotional involvement to the process of professional development. One participant put this as the following:

The EFL teacher should be affectionate, positive, and have a passion for teaching English. As part of the efforts to become a model for students in the classroom, he should strive to create an identity acknowledging the fact that every student is valuable.

In line with this process, it appears that the whole person is considered. This means that cognitive, emotional and motivational aspects are important factors in the professional development of teachers (Hoekstra and Korthagen 2011; Vygotsky 2000).

### **Teaching and Learning Process**

Pre-service teachers commented that effective EFL teachers had the potential of drawing learner's attention to the lesson through giving real-life examples and also could use different teaching methods and materials. These characteristics stressed by the prospective teachers in the interviews are associated with the sub-competence field of 'diversification of teaching' by focusing on lesson planning, materials design and learner diversity. One of the pre-service teachers stressed that "an effective teacher needs to prepare a lesson plan before coming to the classroom". She added "in addition to the lesson plan, the materials that are going to be utilized during the class should be decided in the first place".

Furthermore, some other ways of language teaching such as games, techniques, methods and skills were highlighted by the trainees as follows:

Games are effective tools because of the sense of challenge and competition which they create on students. The main point about the games is whether they suit the levels of students. The teacher should be careful when using them in the classroom. For example, it could be fun if teachers let students play card games in primary schools whereas this could be tedious for the high school students.

One student teacher added that "an EFL teacher should be active and creative during the classes". Otherwise, it can be inferred that students get bored by the mechanical language teaching tasks such as filling the blanks activities and grammar exercises.

Another crucial concern highlighted by student teachers was concerned with treating the errors in the classroom. They pointed out that "an effective teacher should know how to correct the students' errors".

The teacher should not bother students by correcting minor mistakes. Major errors ought to be corrected in a positive manner without humiliating them. The teacher should make them feel that the purpose is not to criticize students due to their errors.

More specifically, another student teacher felt that the act of correcting students' language errors requires the teacher to employ hands-on strategies applicable to the particular teaching context. He goes on to suggest that "the teacher ought to correct learners' errors by ascribing the error in question to the whole class rather than focusing on one student". According to McBer (2000), effective teachers make the most of their professional knowledge by consistently selecting appropriate teaching strategies and exhibiting characteristics, which makes them effective.

### **Classroom Management**

Pre-service teachers' views of classroom management were reflected in their accounts as the following:

The teacher is the moderator of his/her classroom. The control of the classroom falls upon the teacher if something unusual happens. However, teacher should not be too harsh when handling difficulties faced in the classroom. Instead, teacher should behave friendly but should never become a friend of students.

The findings from the analysis of the qualitative data back up the student teachers' perception of authority required of the teacher regarding classroom management. The results indicate that "being authoritative" is considered to be one of the most important futures by prospective teachers in the process of language teaching. Lee, Chang and Tsai (2009) set out to investigate students' perceptions of 'teacher authority' in contrast with 'sharing authority'. They found that students who were in favor

of sharing authority tended to have more positive learning attitudes. In their work, students' preferred teacher authority was characterized as 'sharing authority' and 'teacher-centered authority.'

It was observed that pre-service teachers recognized the need to get prepared for the lesson built upon a sound schedule. It becomes clear that such an approach facilitates the teacher's management of the classroom. The possible outcomes of it were consistently reported from pre-service teachers' perspectives:

The teacher with a proper planning and preparation for the upcoming lesson will always be one step ahead within the context of classroom management. The teacher should not make students feel that he did not prepare for the lesson and use the time effectively. When the teacher does not use the time properly, he is likely to either end the lesson late or struggle to discipline the students in the course of the remaining time as he finished early.

### **Focus on Learner Needs**

The last theme derived from the qualitative data concerns meeting learners' needs, which informs one salient quality of EFL teachers. Specifically, the sub-titles of this theme also embodied the motivational, individual and field-specific issues faced by the teacher. First and foremost, in most of the teacher students' view, "the teacher should get to know his students well and observe them carefully". One of the student teachers' accounts helped to frame the teachers' role in responding to students' needs:

In the first place the teacher ought to get to know students and try to reach them in a way. In the case of students' faults the teacher is supposed to be tolerant. The teacher should be able to give positive feedback and always encourage the student to learn. The teacher should be able to ensure students that they can use inside and outside the classroom and adapt it to their daily lives. An effective English teacher should put great emphasis on students' command of classroom language regardless of grammar teaching at some level. Obviously, this might result in a positive sense of language learning on the part of students and potentially serves as a means of promoting their interest in language learning.

The data from the study make it clear that students' needs in the learning process are diverse. This means that teachers need to handle a wide range of learner needs in the classroom. This is reflected in student teachers' accounts:

In my opinion, the teacher's role is to let students feel comfortable and secure, and they should be guided and supported by the teacher. Unfortunately, learning would not be rewarding at this point. It is so clear that more than half of the class hates English because the texts are by no means interesting. Therefore, the teacher can be more careful when choosing a reading text. At least, they could be related to students' abilities such as painting or music.

### **4. Conclusion**

The outcomes of this study on the underlying characteristics of English language teachers may provide useful insights for teachers, teacher trainers, curriculum developers, and pre-service teachers in EFL contexts and also may serve as a preliminary needs analysis of the initial teacher education system in field-specific contexts like English. It is also hoped that the findings of this study will contribute to understanding pre-service teachers' emerging perceptions of teacher qualities and thus will provide significant insights into future teacher education.

### **References**

- Adiguzel, A. (2005). Avrupa Birligine uyum surecinde ogretmen niteliklerinde yeni bir boyut: bilgi okuryazarligi. *Milli Egitim*, 167, 355-364.
- Arikan, A., Taser, D., & Sarac-Sezer, S. H. (2008). The Effective English Language Teacher from the Perspectives of Turkish Preparatory School Students, *Egitimve Bilim*, 33(150), 42-51.
- Anderson, N. J. (1991). Individual differences in strategy use in second language reading and testing. *The Modern Language Journal*, 75, 20-32.



- Ansari, U. & Malik, S. K. (2013). Image of an effective teacher in 21st century classroom. *Journal of Educational and Instructional Studies in the World*, 3(4), 61-68.
- Avalos, B. (2011). Teacher professional development in *Teaching and Teacher Education* over ten years. *Teaching and Teacher Education*, 27(1), 10-20.
- Badawood, O. (2015). The features of effective English teachers as viewed by English language teachers and high school students in Saudi Arabia. *International Journal of English Language and Linguistics Research*, 3(6), 26-34.
- Bergmark, U., Lundstrom, S., Manderstedt, L., & Palo, A. (2018). Why become a teacher? Student teachers' perceptions of the teaching profession and motives for career choice. *European Journal of Teacher Education*, 1-17.
- Brosh, H. (1996). Perceived characteristics of the effective language teacher. *Foreign Language Annals*, 29(2), 125-36.
- Brown, A.V. (2009). Students' and teachers' perceptions of effective foreign language teaching: A comparison of ideals. *The Modern Language Journal*, 93, 46-50.
- Bikmaz, F. H., & Guler, D. S. (2002). Velilerin sınıf ogretmenlerinden beklentileri ve sınıf ogretmenlerinin bu beklentilere uygunlugu. *Kuram ve Uygulamada Egitim Bilimleri*, 2 (2), 445-472.
- Bulger, S.M., Mohr, D.J. & Walls, R.T. (2002). Stack the deck in favor of your students by using the four aces of effective teaching. *Journal of Effective Teaching*, 5(2).
- Carol R. R. & Miriam B. R. (2006). Presence in teaching. *Teachers and Teaching: theory and practice*, 12(3), 265-287.
- Caliskan, M., Isik, A. N., & Saygin, Y. (2013). Ogretmen adaylarinin ideal ogretmen algilari. *Ilkogretim Online*, 12(2), 575-584.
- Cakmak, M. (2009). Prospective teacher' thoughts on characteristics of an "effective teacher". *Education and Science*, 34 (153), 74-82.
- Cakmak, M., & Gunduz, M. (2018). Pre-service ELT Teachers' Perceptions of Characteristics of Effective Teachers. *GEFAD / GUJGEF*, 38(1), 359-383.
- Fraenkel, J., Wallen, N., & Hyun, H. (2014). *How to design and evaluate research in education* (9th ed.). NY: McGraw-Hill Education.
- Goh, L.H., & K.-C. Loh. (2013). "Let them fish": Empowering Student Teachers for Professional Development through the Project Approach. *Educational Action Research*, 21 (2), 202-217.
- Hargreaves, A. (2000). Four ages of professionalism and professional learning. *Teachers and Teaching: Theory and Practice*, 6 (2), 151-182.
- Hoekstra, A. & Korthagen, F. (2011). Teacher Learning in a Context of Educational Change: Informal Learning versus Systematically Supported Learning. *Journal of Teacher Education*, 62, 76-92.
- Jegade, O., Taplin, M., & Chan, S. (2000). Trainee teachers' perception of their knowledge about expert teaching. *Educational Research*, 42(3), 287-308.
- Kelly, S.N. (2007). High school band students' perceptions of effective teaching. *Journal of Band Research*, 42(2), 57-70.
- Lee, M-H. Chang, C-Y. & Tsai, C-C. (2009). Exploring Taiwanese high school students' perceptions of and preferences for teacher authority in the earth science classroom with relation to their attitudes and achievement. *International Journal of Science Education*, 31(13), 1811-30.
- McBer, H. (2000). Report on research into Teacher Effectiveness. DfEE Research Report. No. 216 Norwich: HMSO.
- Miller, K.L. (1992). Faculty and student perceptions of effective clinical teachers: a replication" Masters Theses. 91. Retrieved from <http://scholarworks.gvsu.edu/theses/9>
- Patton, M. Q. (2002). *Qualitative evaluation and research methods* (3rd ed.). Thousand Oaks, California: Sage Publications.
- Patton, M. Q. (2015). *Qualitative Research and Evaluation Methods*. CA: SAGE.
- Ridgeway, C., & Bowyer, J. (1998). Participants perceptions for valu of a professional development program in elementary science education for their role in school-wide reform. Paper presented at the *National Association for Research in Science Teaching Annual Conference*, San Diego, CA, April.

- Sheridan, L. (2011). Exploring Pre-Service Teachers' Perceptions of Teacher Qualities in Secondary Education: A Mixed-Method Study. Thesis submitted for the degree of Doctor of Philosophy, University of Canberra.
- Sherman, B. R. & Blaackman, R.T. (1975). Personal characteristics and teaching effectiveness of college faculty. *Journal of Educational Psychology*, 67, 124-131.
- Saglam, M., & Kurum, D. (2005). Turkiye ve Avrupa Birligi ulkelerinde ogretmen egitiminde yapisal duzenlemeler ve ogretmen adaylarinin secimi. *Milli Egitim*, 167, 53-70.
- Sunbul, A. M. (2006). Bir meslek olarak ogretmenlik (Ed. Ozcan Demirel, Zeki Kaya). *Egitim Bilimine Giris*, Ankara : Pegem A Yayıncılık.
- Sutkin, G., Wagner, E., Harris, I. and Schiffer, R. (2008). What makes a good clinical teacher in medicine? A Review of the Literature” *AcadMed*, 83(5): 452-66.
- Turner, D. W. (2010). Qualitative interview design: A practical guide for novice investigators. *The Qualitative Report*, 15(3), 754-760.
- Yates, G.C.R. (2005). “How obvious”: Personal reflections on the database of educational psychology and effective teaching research. *Educational Psychology*, 25(6), 681-700.
- Vygotsky, L. S. (2000). *A formação social da mente* (J. Cipolla Neto, L. S. Menna Barreto, & S. C. Afeche, Trads.). São Paulo, SP: Martins Fontes. (Original work published 1933)
- Yildirim, A., & Simsek, H. (2006). *Sosyal Bilimlerde Nitel Arastirma Yontemleri*. Besinci baski. Ankara: Seckin Yayinlari.
- Wichadee, S. (2010). Defining the effective English language teacher: Students' and teachers' perspectives, in Stoke, A.M. (Ed.), *JALT2009 Conference Proceedings*. Tokyo: JALT.
- Zamani, R., & Ahangari, S. (2016). Characteristics of an Effective English Language Teacher (EELT) as Perceived by Learners of English. *Foreign Language Teaching and Research*, 14, 69-88.



# As An Activity Of The Teaching Process: Drawing Attention

Menekse Eskici

## 1. Introduction

The production centre of the education system interacts with the teachers and students in the classrooms where the educational objectives are transformed into behaviour, and teachers play significant roles and tasks in this interaction process (Cakmak, Kayabasi & Ercan, 2008). Indeed, teaching is a process that requires specialised knowledge and skill and the knowledge, skills and attitudes to be gained in the classrooms which are particular educational environments are determined in advance, and they are tried to be given to the students by teaching activities organised in a planned and systematic manner by the teachers. When literature related to these skills is examined, it is seen that instructional management is gathered under six titles; planning, beginning of class, drawing attention, maintaining attention, monitoring, summarising and giving useful feedbacks (Kuran, 2007; Ekici, 2007). Educationally effective management of the class directly or indirectly influences other aspects of classroom management such as behaviour and communication. For this reason, it can be said that the teachers in the specialist position must have the ability to attract attention and maintain attention for qualified class management (Caglar, 2009).

As far as the students are concerned, the focus points are not the subject matter of the course. They are concerned with many different areas of their social life. Some students think about the movie they watched last night, and some students think about the evening match score and some students are thinking of conversations with their colleagues. In such a case, starting the teacher directly from the course subjects will cause the teaching process to fail and the student to lose the positive attitude towards the course. In this case, it is necessary for the teachers to establish a bridge between the students' daily thoughts and the course subjects during the course start-up. This bridge, which will facilitate the transition of pupils to the lecture process, can be established with the attention-grabbing activities that teachers will do during the course. As Senemoglu (2007) pointed out, if the teacher enters the own lesson in a planned, programmed and prepared manner, then the quality of the teaching service will rise. A lesson plan consists of introduction, development, conclusion and evaluation sections. The first step in the introductory course is to draw attention (Sonmez, 2005). Teachers should not start course directly when they enter the class. They should show a story, anecdote and memorandum, video cassette, slides, films, pictures, tables, graphics, maps and so on to attract students attention and target behaviours to be attained,

Successful educational programs must ultimately be designed to attract people's attention (Rose, 2015). Attention can be defined as focusing on a point for a specified period, directing a stimulus, ignoring other stimuli (Cammann & Spiel, 1991; Selcuk & Ozturk 1992) and concentrating on the subject to learn. The most important determinant of the success of the teaching process is the active participation of the student. It can be assumed that the active participation of the students in the teaching process is because the attention of the individual is at the highest level. Attention is one of the useful factors in learning. For the learning to take place, the learner must encounter the stimulant. The realisation of the reception and processing of the stimuli is started with attention (Ozturk, 1999). Despite having different perspectives on the learning, they all say that attention is an indispensable concept on the learning. Learning models accept the concept of attention as the mechanism that initiates learning (Schmidt, 1995).

The attention expressed as a complex neural and psychological phenomenon that comes in many different forms and involves many different brain structures (Dayan, Kakade & Montague, 2000) and mechanisms is explained as the recipient and cognitive processes that bring awareness to conscious stimuli from a neural perspective (Roda & Nabeth, 2005). Attention and memory are closely related to

each other. The focus point of attention is a subset of the short-term memory, and the short-term memory is the long-term memory, the actuation section. Attention can be seen as a part of the memory that provides structure and restriction (Robinson, 2003). For this reason, it can be said that how important the attention factor is in determining the visuals of learning environments (De Castell & Jenson, 2004).

It is also a precondition for the attention learning process (Demir, 2009). It is known that a student with a valid attentional level and a student with inattentive or limited attention have different learning levels (Sunbul & Celik, 1998). For this reason, attracting the attention of the students to the learning before they begin to teach the lesson will increase the stimulation of the students and will make the possibility of keeping the related central details of the course material more memorable (Roda & Nabeth, 2005).

Some of the conclusions related to researchers on the issue of attracting attention in the education-training process are as follows: Ergin, Battal & Cardak, (1999) found that teachers did not give enough attention to attraction and motivation activities in Science and Physics classes as a result of their researchers. As a result of the research done by Dundar (2005) in order to determine what the techniques used by the class teachers at the beginning of their lessons are and what techniques teachers often use and find useful, Dundar found that 75.5% of the teachers were using open-ended questions at the beginning of the course on target behaviors and 74.8% of them were using a technique to bring various materials such as a map, a closed box, etc. and 71.5% of them were using a technique which is checking out previously taught. In contrast, it was identified that the researcher teachers did not use attention-shooting techniques such as flute, alarm, ringing tone at a rate of 51.1% and that they did not use the guest specialists (doctors, police) related to the subject in the classroom at a rate of 33.6%. Also, it was found out that teachers used stories, memories, poetry reading activities related to target behaviours as the most effective attention drawing technique and the least effective ones were flute, alarm, have been identified.

The prominence in the results of the teaching of attention is indisputable. From here, it can be said that successful attention drawing activities can be done by taking the way and positive results can be obtained in the course of education. There is a need for research in this area to plan successful attentional activities. This research aims to determine the proposal of the prospective teachers' attention activities in the teaching process.

## **e) Materials and Methods**

This research is a qualitative research. The phenomenology design, one of the qualitative research types, was used in this study. In the pattern of phenomenology, it is focused on phenomena that are perceived but which do not have an in-depth and detailed understanding (Yildirim and Simsek, 2008). In the research, it was aimed to reveal the thoughts of the prospective teachers about the activities that could be done to attract attention in the course of the lesson.

### **2.1.Participantis**

This research was carried out with 243 (141 female and 102 male) prospective teachers in Kirklareli University in 2017-2018 academic year. Teacher candidates who participated in the research were selected by easy accessibility method.

### **2.2.Data collection tools**

The data of the study were collected by brainstorm technique. An open-ended question was asked of teacher candidates as to what kind of activity should be organised to attract attention during the teaching process. An idea pool was created by writing the answers of the teacher candidates.

### **2.3.Analysis techniques**

Content analysis technique was used to analyzed the data of collected. The answers that were not relevant to the subject were cancelled. The answers given by the teacher candidates are collected under

four central themes, except for the cancelled answers. These four central themes are "using material", "make it enjoyable", "communicating" and "activate students". The related codes are classified under the 4 main themes determined. Generated codes and frequencies of the themes were calculated.

#### f) Findings

Four main themes were formed as "using material", "make it enjoyable", "communicating" and "activate students" as a result of evaluating the views of prospective teachers about their attention-shooting activity. The codes found under this theme are listed, and their frequencies are presented.

##### 3.1.To set up the communication for drawing attention

The responses of teacher candidates under the theme of setting up communication for drawing attention are tabulated as follows.

Table 1. The responses of teacher candidates under the theme of setting up communication for drawing attention

Theme	Code	f
Setting up communication	Asking the question	32
	Using the gesture mimic	17
	Changing the tone of voice	12
	Talking about current topics	9
	Establishing eye contact	7
	Exciting/fluent expression	4
	Suddenly silence	3
	Displacement	2

When Table 1 was examined, it can be seen that the ideas of the teacher candidates were gathered under the theme of communicating for drawing attention such as asking the question (32), using the gesture mimic (17), changing the tone of voice (12), talking about current topics (9), establishing eye contact (7), exciting/fluent expression (4), suddenly silence (3) and displacement (2).

##### 3.2.To activate the student for drawing attention

The responses of teacher candidates under the theme of activating the student for drawing attention are tabulated as follows.

Table 2. The responses of teacher candidates under the theme of activating the student for drawing attention

Theme	Code	f
Activating the student	Making the application giving	34
	Research in advance	14
	Putting awards for events using	5
	The invention strategy	5
	Relocating to students	4

When Table 2 was examined, it can be seen that teacher candidates were gathered under the theme of activating the student for drawing attention such as making the application (34), giving research in advance (14), putting awards for events (5), using the invention strategy (5) and relocating to students (4).

##### 3.3.To make it enjoyable for drawing attention

The responses of teacher candidates under the theme of making it enjoyable for drawing attention are tabulated as follows.

Table 3. The responses of teacher candidates under the theme of making it enjoyable for drawing attention

Theme	Code	f
Making it enjoyable	Playing games	38
	Making a joke	21
	Telling a story	11
	Singing	8

When Table 3 is examined, it can be seen that the ideas of the teacher candidates were gathered under the theme of making it enjoyable for drawing attention such as playing games (38), making a joke (21), telling a story (12), and singing (8).

### 3.4.To use the material for drawing attention

The responses of teacher candidates under the theme of using the material for drawing attention are tabulated as follows.

Table 4. The responses of teacher candidates under the theme of using the material for drawing attention

Theme	Code	f
Using the material	Getting them Watch video	27
	Showing a picture	19
	Bringing objects	10
	Visualizing with table etc.	7

When Table 4 was examined, it can be seen that the ideas of the teacher candidates were gathered under the theme of using the material for drawing attention such as getting them watch video (27), showing a picture (19), bringing objects (10), and visualizing with table etc. (7).

### g) Discussion and Conclusion

Within the purpose of this research, it has been tried to determine the thoughts of the prospective teachers about how they will draw the attention of the students to increase the success of the teaching process. It has been observed that the views of the teacher candidates are gathered under four central themes: "using material", "make it enjoyable", "communicating" and "activate students". It was found that the ideas of the teacher candidates were gathered under the theme of communicating for drawing attention such as asking the question (32), using the gesture mimic (17), changing the tone of voice (12), talking about current topics (9), establishing eye contact (7), exciting / fluent expression (4), suddenly silence (3) and displacement (2). Education is a communicative process. Educational efficiency is also related to the communication between teachers and students (Bolat, 1996; Dunbar, Brooks & Kubicka-Miller, 2006).

Asking questions triggers thinking and learning (Kilinc and Caliskan, 2015). Marx, Fuhrer & Hartig (1999) stated that asking questions reinforces communication and encourages students to learn. This also supports the results of the research. Sevik (2005) emphasized the importance of the problem in the teaching process and stated that teachers should develop themselves in this respect. It is emphasized by Caliskan and Yesil (2005) that the communication skills of teachers are essential for the classroom climate to be noteworthy, especially the communication of the students with the correct use of body language by the teachers. Teachers use verbal communication in classroom communication as well as nonverbal communication. Teachers use nonverbal communication more than verbal communication (Ozbent, 2007). The non-verbal communication performed by the teachers in the body language is quite useful in giving the desired messages to the students during the education process (Miller, 2005). When the literature is examined, it is seen that there are studies showing that using the gestures and mimics correctly by the teachers is effective on the efficiency in education (Bencuya, 2003; Celep, 2008; Dagli & Oner, 2002; Gokceli, 2013; Gulec & Temel, 2015; Habaci, Urker, Bulut, Atici & Habaci, 2013; Khan, Mohammad, Shah & Farid, 2016; Sadioglu, 2018; Sen, 2006; Yildizhan, 2014). It can be said that

research findings emphasizing the importance of nonverbal communication within the classroom in the literature match up with the results obtained in this research findings such as asking the question, using the gesture mimic, changing the tone of voice, talking about current topics, establishing eye contact, exciting/fluent expression, suddenly silence and displacement.

It can be seen that teacher candidates were gathered under the theme of activating the student for drawing attention such as making the application (34), giving research in advance (14), putting awards for events (5), using the invention strategy (5) and relocating to students (4). When the literature is examined, it is seen that there are many studies emphasising that the student should be active in the education process (DeLozier & Rhodes, 2017; Freeman, Eddy, McDonough, Smith, Okoroafor, Jordt, & Wenderoth, 2014; Hancer, Sensoy, & Yildirim, 2003; Mennella, 2016; Roman & Uttamchandani, 2018). It is stated by Cavus (2005) that having class activities has positive results for both students and teachers in the teaching process. This research which is the emphasis on the importance of the activity of teacher candidates is parallel to Topcu (2017) research that teacher candidate activated teaching of extracurricular activities. There is also research (Alev & Yigit, 2006; Aydin, 2011; Bryan & Nelson, 1994; Deveci & Onder, 2014; Epstein & Van Voorhis, 2001; Paschal, Weinstein & Walberg, 1984) indicating that giving research assignments to students supporting these research findings is a factor in activating the student.

It can be seen that the ideas of the teacher candidates were gathered under the theme of making it enjoyable for drawing attention such as playing games (38), making a joke (21), telling a story (12), and singing(8). When the literature is examined, it is seen that educational games are the researches (Akgun, Nuhoglu, Tuzun, Kaya & Cinar, 2011; Conati, 2002; Habgood & Ainsworth, 2011; Karamustafaoglu & Kaya, 2017; Topcu, Kucuk & Goktas, 2014; Yurt, 2007) that reveal their effects on success in the teaching process. Same way, the research of teacher candidates in this study to make jokes to add fun to the teaching process is match with researchs (Altinkurt & Yilmaz, 2011; Asilioglu, 2013; Aydin, 2006; Balta, 2016; Garner, 2006; Jeder, 2015; Lei, Cohen & Russler, 2010; Sahin, 2010; Topcuoglu, 2007) indicating the importance of humour in the educational process in the literature.

It is seen that the ideas of the teacher candidates were gathered under the theme of using the material for drawing attention such as getting them to watch video (27), showing the picture (19), bringing objects (10), and visualising with table etc. When the literature is examined, it is seen that there are much researchs (Bernier, 1993; Demiralp, 2007; Duman, 2013; Kazu & Yesilyurt, 2008; Kreijns, Van Acker, Vermeulen & Van Buuren, 2013; Saka & Akdeniz, 2006; Yazici, 2015). that emphasises the importance of using materials on teaching. Baylak (2016) stated that the 3D simulation method has a significant effect on the students' acquisition of field experience. Similarly, Zengin, Kirilmazkaya & Kececi, (2012) stated that the use of intelligent boarding in the course of the lesson positively affects the attitudes and achievements of the students. The researches in the literature show that the suggestions of prospective teachers overlap in many places. It is seen that researches in the literature match up with teacher candidates suggestions related drawing attention. In this context, it is possible to take into consideration the proposal of drawing attention activity which has been put forward within the scope of the research while educational activities are planned.

## References

- Akgun, E., Nuhoglu, P., Tuzun, H., Kaya, G., & Cinar, M. (2011). Bir Egitsel Oyun Tasarimi Modelinin Gelistirilmesi. *Egitim Teknolojisi kuram ve uygulama*, 1(1), 41-61.
- Alev, N., ve Yigit, N. (2006). Tezsiz yuksek lisans (TYL) programindaki uygulamali derslerde uygulamanin bir parcasi olan odevler hakkında ogretmen adaylarinin gorusleri. *Turk Egitim Dergisi*, 3(4), 275-285.
- Altinkurt, Y. ve Yilmaz, K. (2011). Ilkogretim okulu ogretmenlerinin mizah tarzleri. *Pegem Egitim ve Ogretim Dergisi*, 1(2), 1-8.
- Asilioglu, B. (2013). Mizahin anlami ve egitimdeki yeri. *Bayburt Universitesi Egitim Fakultesi Dergisi, Egitim Felsefesi Ozel Sayisi* 1, 207-243.
- Aydin, F. (2011). Cografya Dersinde Verilen Odevlerin Ogrenci Goruslerine Gore Degerlendirilmesi. *Pamukkale Universitesi Egitim Fakultesi Dergisi*, 29(29), 27-41.



- Aydin, I. S. (2006). *Turkce derslerinde mizah kullaniminin ogrenci tutum ve basarisina etkisi (Izmir ilkogretim 8. sinif orneklemesinde)*. Yayimlanmamis Doktora Tezi, Dokuz Eylul Universitesi, Izmir.
- Balta, E. E. (2016). Egitimde Mizahin Kullanimina Iliskin Ogretmen Tutumlari. *Elementary Education Online*, 15(4): 1268-1279.
- Baylak, H.M. (2016). Physical geography teaching with 3D simulation. *International Journal of Contemporary Educational Research*, 3(2), 65-70.
- Bencuya, C. (2003). *Ogretmenlerin iletisim becerisi egitimi almasinin ogrenciler uzerindeki etkileri*. Yayimlanmamis Yuksek Lisans Tezi. Marmara Universitesi Sosyal Bilimler Enstitusu, Istanbul.
- Bernier, M. J. (1993). Developing and evaluating printed education materials: a prescriptive model for quality. *Orthopedic Nursing*, 12(6), 39-46.
- Bolat, S. (1996) "Egitim Ogretimde Iletisim: Hacettepe Egitim Fakultesi Uygulaması" *Hacettepe Egitim Fakultesi Dergisi*, 12, 75-78.
- Bryan, T., ve Nelson, C. (1994). Doing homework: Perspectives of elementary and junior high school students. *Journal of Learning Disabilities*, 27(8), 488-99.
- Cammann, R. & Spiel, G. (1991). Neurophysiologische Grundlagen von aufmerksamkeits- und konzentrationsleistungen. In H. Barchmann, W. Kinze & N. Roth (Eds.), *Aufmerksamkeit und Konzentration im Kindesalter: interdisziplinare Aspekte* (pp. 11-26). Verlag Gesundheit, Berlin.
- Celep, C. (2008). Sinif yonetiminde kuram ve uygulama. 3. *Baski, Ankara: Pegem Akademi Yayıncılık*.
- Conati, C. (2002). Probabilistic assessment of user's emotions in educational games. *Applied artificial intelligence*, 16(7-8), 555-575.
- Caglar, A. (2009). *Sinif ogretmenlerinin ogretimsel etkinliklerin yonetiminde dikkat cekme ve surdurme davranislarinin incelenmesi*. Yuksek lisans tezi. Adana: Cukurova Universitesi Sosyal Bilimler Enstitusu
- Cakmak, M., Kayabasi, Y., & ERCAN, L. (2008). Ogretmen adaylarinin sinif yonetimi stratejilerine yonelik gorusleri. *Hacettepe Universitesi Egitim Fakultesi Dergisi*, 35(35).
- Caliskan, N. ve Yesil, R. (2005): Egitim surecinde ogretmenin beden dili. *Gazi Universitesi Kirsehir Egitim Fakultesi Dergisi*, 6(1), 199-207.
- Dagli, A., & Oner, M. (2002). Ilkogretim okullarinin ikinci kademesinde okuyan ogrencilerin fen bilgisi ogretmenlerinin sinif ici iletisim davranislarina iliskin algilari. *Cagdas Egitim*, 292, 23-30.
- Dayan, P., Kakade, S., & Montague, P. R. (2000). Learning and selective attention. *nature neuroscience*, 3(11s), 1218.
- De Castell, S., & Jenson, J. (2004). Paying attention to attention: New economies for learning. *Educational Theory*, 54(4), 381-397.
- DeLozier, S. J., & Rhodes, M. G. (2017). Flipped classrooms: a review of key ideas and recommendations for practice. *Educational Psychology Review*, 29(1), 141-151.
- Demir, Y. M. (2009). Bilisel bilgi islem teorisi. M. Sahin (Ed.), *Ogrenme teorileri* (s. 130-182). Nobel, Ankara.
- Demiralp, N. (2007). Cografya egitiminde materyaller ve 2005 cografya dersi ogretim programi. *Kastamonu Egitim Dergisi*, 15(1), 373-384.
- Deveci, I., & Onder, I. (2014). Opinions of teachers regarding homework assignments given in science and technology course. *Elementary Education Online*, 13(1), 33-47.
- Duman, G. B. (2013). Turkcenin yabancı dil olarak egretiminde materyal gelistirme ve materyallerin etkin kullanimi. *Ana Dili Egitimi Dergisi*, 1(2), 1-8.
- Dunbar, N. E., Brooks, C. F., & Kubicka-Miller, T. (2006). Oral communication skills in higher education: Using a performance-based evaluation rubric to assess communication skills. *Innovative Higher Education*, 31(2), 115.
- Dundar, S. (2005). Sinif ogretmenleri tarafından kullanilan dikkat cekme teknikleri. XIV. Ulusal Egitim Bilimleri Kongresi. Denizli: Pamukkale Universitesi. 28-30 Eylul 2005.
- Ekici, G. (2004) Ilkogretim 1. Kademe Ogretmenlerinin Sinif Yonetimi Profillerinin Degerlendirilmesi. *Egitim ve Bilim Dergisi*, Cilt: 29, Sayi: 131
- Epstein, J. L., & Van Voorhis, F. L. (2001). More than minutes: Teachers' roles in designing homework. *Educational psychologist*, 36(3), 181-193.

- Ergin, O., Battal, N., & Cardak, Z. E. (1999). Fen bilgisi ve Fizik derslerinde dikkat cekme ve guduleme etkinlikleri. *DEU. Buca Egitim Fakultesi Dergisi*, 19, 192-197.
- Freeman, S., Eddy, S. L., McDonough, M., Smith, M. K., Okoroafor, N., Jordt, H., & Wenderoth, M. P. (2014). Active learning increases student performance in science, engineering, and mathematics. *Proceedings of the National Academy of Sciences*, 111(23), 8410-8415.
- Garner, R. L. (2006). Humor in pedagogy: How ha-ha can lead to aha! *College Teaching*, 54 (1), 177-180.
- Gokceli, S. (2013). Lise ogrencilerinin ogretmenlerin beden diline yonelik tutumlari: Adana-Kozan Fatih Anadolu Lisesi ornekleme, *Adiyaman Universitesi Sosyal Bilimler Enstitusu Dergisi Turkcenin Egitimi Ogretimi Ozel Sayisi*, 6 (11).
- Gulec, S., & Temel, H. (2015). Body language using skills of teacher candidates from Departments of Mathematics Education and Social Studies Education. *Procedia-Social and Behavioral Sciences*, 186, 161-168.
- Habaci, I., Urker, A., Bulut, S., Atici, R., & Habaci, Z. (2013). Beden dilinin egitim ogretim uzerine etkileri. *Electronic Turkish Studies*, 8(9), 1639-1655.
- Habgood, M. J., & Ainsworth, S. E. (2011). Motivating children to learn effectively: Exploring the value of intrinsic integration in educational games. *The Journal of the Learning Sciences*, 20(2), 169-206.
- Hancer, A. H., Sensoy, O., & Yildirim, H. I. (2003). ilkogretimde cagdas fen bilgisi ogretiminin onemi ve nasil olmasi gerektiği uzerine bir degerlendirme. *Pamukkale Universitesi Egitim Fakultesi Dergisi*, 13(13), 80-88.
- Jeder, D. (2015). Implications of using humor in the classroom. *Procedia-Social and Behavioral Sciences*, 180, 828-833.
- Karamustafaoglu, O., & Kaya, M. (2017). Egitsel oyunlarla “yansima ve aynalar” konusunun ogretimi: Yansimali kosu ornegi. *Journal of Inquiry Based Activities*, 3(2), 41-49.
- Kazu, H., & Yesilyurt, E. (2008). Ogretmenlerin ogretim arac-gereclerini kullanim amaclari. *Firat Universitesi Sosyal Bilimler Dergisi*, 18(2), 175-188.
- Khan, N., Mohammad, N., Shah, N., & Farid, N. (2016). A Study of the Use of Eye Contact in Teaching Learning Process at Secondary Level in District Peshawar. *Language in India*, 16(4).81-97.
- Kilinc, G., Caliskan, H. (2015). Sosyal Bilgiler Ogretmenlerinin Sinif Ici Ders Isleme Surecindeki Soru Sorma Davranislarinin Degerlendirilmesi. *Abant Izzet Baysal Universitesi Egitim Fakultesi Dergisi*, 15(USBES Ozel Sayisi I), 265-286.
- Kreijns, K., Van Acker, F., Vermeulen, M., & Van Buuren, H. (2013). What stimulates teachers to integrate ICT in their pedagogical practices? The use of digital learning materials in education. *Computers in human behavior*, 29(1), 217-225.
- Kuran, K. (2007), “Sinif Ogretmenlerinin Sinif ici Ogretim sureclerindeki Yeterliliklerinin Degerlendirilmesi” *Egitim ve Bilim*, Cilt: 28, Sayi: 130
- Lei, S. A. Cohen, J. L. & Russler, K. M. (2010). Humor on learning in the college classroom: Evaluating benefits and drawbacks from instructors' perspectives. *Journal of Instructional Psychology*, 37(4), 326.
- Marx, A., Fuhrer, U., & Hartig, T. (1999). Effects of classroom seating arrangements on children's question-asking. *Learning Environments Research*, 2(3), 249-263.
- Mennella, T. A. (2016). Comparing the Efficacy of Flipped vs. Alternative Active Learning in a College Genetics Course. *The American Biology Teacher*, 78(6), 471-479.
- Miller, P. W. (2005). Body Language in the Classroom. *Techniques: Connecting education and careers*, 80(8), 28-30.
- Ozturk, B. (1999). Ogrenme ve ogretmede dikkat. *Milli Egitim Dergisi*, 144, 51-58.
- Paschal, R. A., Weinstein, T., & Walberg, H. J. W. (1984). The effects of homework on learning: A quantitative synthesis. *The Journal of Educational Research*, 78(2), 97-104.
- Robinson, P. (2003). Attention and memory during SLA. In C. Doughty & M. Long (Eds.), *Handbook of Second Language Acquisition*, pp.631-662. Oxford: Blackwell.
- Roda, C., & Nabeth, T. (2005). The Role of Attention in the Design of Learning Management Systems. In *CELDA* (pp. 148-155).
- Roda, C., & Nabeth, T. (2005). The Role of Attention in the Design of Learning Management Systems. In *CELDA* (pp. 148-155).

- Roman, T. A., & Uttamchandani, S. (2018). Researching pedagogy within small active learning classrooms: examining enacted pedagogies of learner and instructor interactions. *International Journal of Research & Method in Education*, 1-21.
- Rose, M. (2015). Why attention is essential to learning and the formation of memory. <https://elearningindustry.com/attention-essential-learning-formation-memory>
- Sadioglu, O. (2018). Ogretmenlik Uygulamasi Alan Sinif Ogretmeni Adaylarinin Sinifta Kullandiklari Beden Dilinin Incelenmesi. *Mehmet Akif Ersoy Universitesi Egitim Fakultesi Dergisi*, (45), 190-209.
- Saka, A., & Akdeniz, A. R. (2006). Genetik konusunda bilgisayar destekli materyal gelistirilmesi ve 5E modeline gore uygulanmasi. *The Turkish Online Journal of Educational Technology*, 5(1), 129-141.
- Schmidt, R. W. (1995). Consciousness and foreign language learning: A tutorial on the role of attention and awareness in learning. In R. Schmidt (Ed.), *Attention and awareness in foreign language learning* (pp. 1-63). Honolulu: University of Hawaii Press.
- Selcuk, Z. ve Ozturk, B. (1992). Ogrenme-Ogretme etkinligini artirmada ogrenme stratejilerinin kullanilmasi; genel bir inceleme. *Egitim Dergisi*, 1, 66-74.
- Senemoglu, N. (2007). Gelisim ogrenme ve ogretim: Kuramdan uygulamaya. *Gonul Yayincilik*.
- Sunbul, A. M. ve Celik, M. (1998). Basarili ve basarisiz ogrencilerin dikkat duzeylerinin karsilastirilmasi. *VII. Ulusal Egitim Bilimleri Kongresi Bildirileri* (ss.437-447). Konya: Selcuk Universitesi Egitim Fakultesi.
- Sahin, C. (2005) Ilkogretim II. Kademesinde Matematik Dersinin Ogrenme Ogretme Surecinde Yapilan Etkinliklerin Ogretmen ve Ogrenci Acisindan Degerlendirilmesi. *Eurasian Journal of Educational Research*, 18, 171-185.
- Sahin, O. (2010). Sosyal bilgiler ogretiminde mizah kullaniminin ogrencilerin akademik basarilarina ve tutumlarına etkisi. *Mehmet Akif Ersoy Universitesi Sosyal Bilimler Enstitusu Dergisi*, (3), 56-73.
- Sen, S. (2006). *Sinif ici iletisimde beden dili (Anadolu Otelcilik ve Turizm Meslek Lisesi ogretmenlerinin beden dilini kullanma duzeylerinin belirlenmesine yönelik bir Arastirma)*. Yayinlanmamis yuksek lisans tezi. Ankara: Gazi Universitesi Egitim Bilimleri.
- Topcu, E. (2017). Out of School Learning Environments in Social Studies Education: A Phenomenological Research with Teacher Candidates. *International Education Studies*, 10(7), 126-142.
- Topcu, H., Kucuk, S., & Goktas, Y. (2014). Sinif ogretmeni adaylarinin ilkogretim matematik ogretiminde egitsel bilgisayar oyunlarinin kullanimina yönelik gorusleri. *Turkish Journal of Computer and Mathematics Education (TURCOMAT)*, 5(2), 119-136.
- Topcuoglu, H. (2007). Egitimde mizahin onemi. *MEB Bilim ve Aklin Aydinliginda Egitim*, 7(84), 38-43.
- Yazici, O. (2015). Cografya bolumu ogrencilerinin uc boyutlu gorsel materyal gelistirmelerine yönelik deneyimleri: Karabuk universitesi ornegi. *Marmara Cografya Dergisi*, (31), 98-131.
- Yildizhan, N. (2014). *Lise ogrencilerinin, cografya ogretmenlerinin beden dili hareketlerine yönelik gorusleri*. Yayinlanmamis yuksek lisans tezi. Ankara: Gazi Universitesi Egitim Bilimleri Enstitusu.
- Yurt, E. (2007). Egitsel oyun teknigi ile fen ogretimi ve yeni ilkogretim mufredatındaki yeri ve onemi (Mugla Ili Merkez Ilce Ornegi). *Mugla Universitesi Fen Bilimleri Enstitusu, Mugla*.
- Zengin, F. K., Kirilmazkaya, G., & Kececi, G. (2012). Elementary Students Use of Smart Board The Effect of Achievement and Attitude in Science and Technology Course. *Education Sciences*, 7(2), 526-537.

# **Effect of C Programming Language Instruction on Attitudes of the Students of the Biology Department towards Computer Programming**

Arzu Deveci Topal, Esra Coban Budak, Aynur Kolburan Gecer

## **1. Introduction**

Today, it is important for students to be able to use technology effectively and efficiently. One of the ways which will enable students to have the skills necessary to effectively use existing technologies is to teach computer programming. There are various researches in the literature in this regard (Akpinar and Altun, 2014; Cakiroglu, Sari and Akkan, 2011). Akpinar and Altun (2014) state that digital literacy and motivation of students for school and courses will improve if they are taught computer programming and design tools.

Programming languages are recently being learned and used by many profession groups except computer programmers. One of these fields is biological science. Biology has become an interdisciplinary science, and computer science has begun to have an important place in this field. Biology and computer science have a long and mutual relationship for decades. As information about biological systems increases rapidly, advanced methods to process information are needed more. In particular, it is important that students studying in the department of biology should be able to examine and research biological data using mathematical methods and to integrate biological data sets, and they must have computer skills and know the programming logic that involves systematic resolution of a problem. Programming languages are frequently used to analyse data in bioinformatics and system biology, molecular biology and genetics by statistical and data mining methods.

Navlakha and Bar - Joseph (2011) found that examples of biological systems in nature have inspired many computational algorithms; that both systems have parallel requirements and that one can be learned from the other. The learning of programming languages contributes to computational thinking skills. Individuals who have gained the ability of computational thinking will have the knowledge, skills and attitudes necessary to use computers to solve life problems for production purposes (Ozden, 2015). Qin (2009) stated that many students in life sciences are often weak in quantitative / computing skills and avoid computer based courses. Therefore, developing positive attitudes towards programming languages can contribute to the improvement of computational thinking skills of individuals. According to Hawk (2009), having basic programming expertise, will make biologists more effective as a scientist and will prepare them for a good career in an increasingly data-driven field.

Law, Li and Yu (2010) found out that if individual attitudes and expectations are positive in programming education, individuals can be better motivated. For this purpose it is important to determine the attitudes of the students of the biology department, who are biologists of the future and will analyse the biological data, towards programming. There was no study to measure the attitudes of students in biology department to programming in the literature. A great majority of the researches done has been conducted by students studying in the computer department. In this study, it was aimed to determine the effect of the C programming language applied in the programming course on the attitudes of the students of the biology department towards computer programming. Sub-problems of the research carried out are:

1. Does the C programming language affect the perceptions of the students in the biology department regarding their attitudes towards computer programming?
2. Does the biology department's students' attitudes towards computer programming differ significantly by their demographics (gender, computer ownership, duration of daily computer use, situations of having previously taken programming lessons and having written programs before)?

## 2. Method

The experimental model was used in this study. Designing was done according to a single group post test pattern from experimental models. Pre-test post-test experimental model without control group was used in the study (Buyukozturk et al., 2008). In this model, the effect of the experimental process was examined on a single group and the same measurement tools were randomly applied as pre-test and post-test on the same group.

### 2.1. Sample

This study was carried out within the scope of "Basic Computer Sciences" course with first grade biology students studying at a state university.

29 students studying in the first grade of biology department of Kocaeli University in the academic year of 2017-2018 participated in the study. Demographic characteristics of the students participating in the research are given in Table 1. According to these findings, a great majority of the participants in the study were female (82.8%) and 58.6% had their own computers. Only 3 people have already taken a programming course and the majority (65.5%) use computer less than 1 hour per day.

**Table 1.** Demographic characteristics of students participating in the research

<b>Gender</b>	<b>N</b>	<b>%</b>
Woman	24	82,8
Man	5	17,2
<b>Do you have a computer?</b>		
Yes	17	58,6
No	12	41,4
<b>Daily computer usage time</b>		
Less than 1 hour	19	65,5
1-3 hours	8	27,6
Over 3 hours	2	6,9
<b>Those having previously taken programming lessons</b>	5	17,2
<b>Those having written programs before</b>	4	13,8

### 2.2. Data Collection Tools

Scale of Attitude Towards Computer Programming used in the research was developed by Baser (2013, a). The scale is a 5 point likert type and consists of 38 items. It has four sub-dimensions called "self confidence and motivation in programming", "benefit of programming", "attitude towards success in programming" and "social perception of success in programming". The internal consistency coefficient was 0.953 for the whole scale. Factors account for 60.3% of the variance.

### 2.3. Experimental Process

Algorithms and C programming language which constitute the working logic of computer were taught in this course and the study continued for 12 weeks with 4 hours of lesson per week. The aim of the study is to determine how programming language teaching affects students' attitudes towards programming. While designing weekly lessons in the study, the programming steps that almost all programmers apply were used. The distribution of the subjects on a weekly basis is given in Table 2.

**Table 2.** Distribution of subjects by week

Week	Subject
1	Identifying the problem and developing solutions. Definition and types of algorithms, Operators used in algorithms and algorithm examples, flow diagrams
2	Process Structure in Algorithms: Variable, assignment-transfer, increment-decrement concepts, sequential addition and multiplication, algorithms and flow diagrams
3	Sequential examples of decision and loop algorithms. Array and matrix algorithms
4	Introduction to C programming language
5	Writing, compiling and running simple C programs
6	Login and logout commands in C language
7	if/switch-case statement in C language
8	Loop statement (for, while, do while) in C language
9	Function or method declarations in C language
10	Array type variables
11	String type variables
12	Writing various programs in C language

#### 2.4. Analysis of Data

The data were analyzed with SPSS 18.0 program. Descriptive statistics, frequency analysis, mean, standard deviation, matched and independent sample t test were applied. The level of significance was accepted as 0.05. When the responses to scale items are assumed to be equal in degree range, the highest value is subtracted from the lowest value and divided by the number of degrees. The value of this range is  $4/5 = 0.8$  and is given in Table 3.

**Table 3.** Limits of Score Distribution Related to the Research Scale

Options	Limits
I absolutely agree / Always (5)	4.20-5.00
I agree / Most of the time (4)	3.40-4.19
I agree a little / Sometimes (3)	2.60-3.39
I do not agree / Occasionally (2)	1.80-2.59
I strongly disagree / Never (1)	1.00-1.79

### 3. Findings

A matched group t-test was conducted to determine the difference between students' perception levels of their attitudes towards programming before and after algorithms and programming instruction, and the results are given in Table 4. According to this table, there was a significant difference in students' attitudes towards programming between before and after the programming course in favour of the final test ( $t(28) = 2,063, p < .05$ ). When the students' attitudes towards programming were examined in terms of sub-dimensions, a significant difference was found only in the sub-dimension of benefit of programming ( $t(28) = 2,262, p < .05$ ), no significant difference was found in other dimensions. This finding suggests that 12 weeks of programming instruction positively affected biology students' attitudes towards computer programming.

**Table 4.** T-test results of pre-test and post-test mean scores of students' attitudes towards programming

<b>Attitude toward to computer programming</b>		<b>X</b>	<b>N</b>	<b>S.d.</b>	<b>t</b>	<b>df</b>	<b>p</b>
Confidence and motivation in learning programming	Pretest	53,31	29	10,61	1,418	28	0,167
	Posttest	56,14		12,69			
Usefulness of programming	Pretest	26,62	29	9,44	2,262	28	0,032
	Posttest	29,72		10,55			
Attitude toward success in programming	Pretest	16,59	29	7,42	0,023	28	0,982
	Posttest	16,62		8,27			
Social perception of success in programming	Pretest	4,66	29	1,80	1,931	28	0,064
	Posttest	5,41		2,11			
Total	Pretest	101,17	29	22,37	2,063	28	0,048
	Posttest	107,97		24,39			

In order to determine the levels of perception for attitudes towards programming, the descriptive statistics of the items in the scale applied to the students were calculated and the findings are given in Table 5. Levels of students' attitudes towards computer programming are generally moderate in self-confidence and motivation and benefit sub-dimensions, but they are low in sub-dimensions of attitude towards success in programming and social perception of success.

**Table 5.** Perception levels of biology students' attitudes towards programming

<b>Attitude toward to computer programming</b>	<b>N</b>	<b>Item number</b>	<b>x</b>	<b>ss</b>
Total		38	2,84	0,64
Confidence and motivation in learning programming	29	17	3,30	0,75
Usefulness of programming		10	2,97	1,05
Attitude toward success in programming		8	2,08	1,03
Social perception of success in programming		3	1,80	0,70

The post test scores of the students were compared with the Mann Whitney U test according to gender, computer availability, daily computer use, having previous programming lessons, and written programs before (Table 6) and a significant difference in favour of those who had never programmed before was found only between attitudes of those who had written and not written programmes before. As a result of the single sample Kolmogorov-Smirnov test applied to determine whether the scores previously obtained from scales of attitude towards programming according to having written programme before had a normal distribution, the difference of the distribution from the normal distribution was not found significant ( $z = 1,170$ ,  $p > .05$  for computational thinking and  $z = 1.244$ ;  $p > .05$  for attitude toward programming).

**Table 6.** Comparison of attitude scores towards programming according to the situation of having previously written program

Having written programs before		N	S.T.	S.O.	U	z	p
Attitude toward computer programming	Yes	4	6,00	24,00			
	No	25	16,44	411,00	14,00	-2,278	0,020
Total		29					

#### 4. Conclusion and Discussion

In this study, it was aimed to determine the effect of the programming instruction course on the attitudes of the students of the biology department towards computer programming. For this purpose, a study for 12 weeks was planned and the scale of attitude towards computer programming was applied to the students before and after the study. According to the results of the study, it was found out that teaching of programming had a positive influence on the level of the biology students' attitudes towards computer programming at the end of the study. Qin (2009) presented computational thinking and experience of practical learning to students through bioinformatics course; students positively perceived this learning experience and realized that their computer knowledge and computing skills improved.

It has been determined that the attitudes of the students towards computer programming are moderate, they are moderate also in self - confidence and motivation and benefit sub - dimensions, however they are low in sub-dimensions of attitude towards success in programming and social perception of success. In a study of the field conducted by biology teachers working in secondary schools, it was observed that the teachers showed positive attitudes towards using word processing, e-mail and internet, presentations, use of data recorders, use of computer programs and virtual laboratories, but they showed negative attitudes about programming and computer games, and that the importance teachers perceived on the topic and the use of computer software were related to each other (Šorgo, A., Verčkovnik, T., Verčkovnik, T., Kocijančič, S., 2010). In addition, it has been determined in studies carried out by the students studying in computer sciences that they developed a positive attitude towards programming (Baser, 2013, b; Law, Li and Yu, 2010)

Furthermore, it has been determined that the attitudes of students who have already written a program using a programming language are lower than those who have never written a program. This may be due to the previous negative experiences of the students.

As a result, in this study, the attitudes of the students towards programming became more positive after programming language teaching. However, students' attitudes towards programming were found to be moderate. Individuals with developed problem-solving skills will also have positive attitudes towards programming. Therefore, longer-term and individually planned practices can be performed to improve problem-solving skills of students in biology departments so that they can develop a more positive attitude.

#### 5. References

- Akpinar, Y. & Altun, Y. (2014). The Need for Programming Education in Information Society Schools. *Elementary Education Online*, 13(1), 1- 4.
- Baser, M. (2013), (a). Attitude Scale Development Study for Computer Programming. *The Journal of Academic Social Science Studies*, 6(6), 199-215.
- Baser, M. (2013), (b). Attitude, Gender and Achievement in Computer Programming. *Middle-East Journal of Scientific Research* 14 (2), 248-255. DOI: 10.5829/idosi.mejsr.2013.14.2.2007.
- Buyukozturk, S., Cakmak, E. K., Akgun, O. E., Karadeniz, S. & Demirel, F. (2008). *Scientific Research Methods*. Ankara: Pegem A Yayıncılık.
- Cakiroglu, U., Sari, E. & Akkan, Y. (2011). The View of the Teachers about the Contribution



of Teaching Programming to the Gifted Students in the Problem Solving. *Paper presented at 5th International Computer & Instructional Technologies Symposium (22-24 September)*, Firat University, Elazig.

Hawks (2009). Why Biology Students Should Learn How To Program.

<https://www.wired.com/2009/03/why-biology-students-should-learn-how-to-program/>

Law, K. M.Y., Lee, V.C.S. & Yu, Y.T. (2010). Learning Motivation in E-Learning Facilitated Computer Programming Courses. *Computers&Education*, 55(1),218-228.  
<https://doi.org/10.1016/j.compedu.2010.01.007>

Navlakha, S. & Bar-Joseph, Z.(2011). Algorithms in Nature: The Convergence Of Systems Biology and Computational Thinking. *Molecular Systems Biology*, 7(1), 546. doi :10.1038/msb.2011.78. <http://msb.embopress.org/content/7/1/546.export>

Qin, H. (2009). Teaching Computational Thinking Through Bioinformatics to Biology Students. *Proceedings of the 40th ACM Technical Symposium on Computer Science Education SIGCSE '09*, 188-191, USA: Chattanooga. ISBN: 978-1-60558-183-5  
<http://doi.acm.org/10.1145/1508865.1508932>

Šorgo, A., Verčkovnik, T., Verčkovnik, T., Kocijančič, S. (2010). Information and communication technologies (ICT) in Biology Teaching in Slovenian Secondary Schools. *Eurasia Journal of Mathematics, Science and Technology Education*, 6(1), 37-46.  
<https://doi.org/10.12973/ejmste/75225>

# Recreational Activity Habits of Undergraduate Students and Factors Affecting Their Habits: The Case of Kastamonu University Landscape Architecture Department Students

Merve Kalayci, Sevgi Ozturk

## 1. Introduction

In today's industrialized country societies, people have to work like a machine sparing no time for themselves. This adversely affects individuals in terms of both their psychology and physiology and causes them to be unhealthy individuals. Unhealthiness starting from the individual gradually becomes a communal problem (Ergul, Alp, & Camliyer, 2015). To prevent this, one needs to learn how to manage time and live according to a program (Gungormus, Yetim, & Calik, 2006; Ayyildiz Durhan, Akgul, & Karakucuk, 2017). Individuals who are able to manage time and live according to a program will have time for themselves after carrying out the activities they are obliged to carry out in order to maintain their lives. In leisure time, the individuals carry out the activities they volunteer to do; thus they can experience both psychological relief and increase their productivity during working hours (Huang & Carleton, 2003, Onder, 2003, Gungor & Cengiz, 2006, Tel & Koksalan, 2008, Sabbag & Aksoy, 2011, Tutuncu, Aydin, Kucukusta, Avci, & Tas, 2011). As Tumer (1975) and Uzun & Altunkasa (1991) stated, activities voluntarily carried out by people in their leisure time can be defined as recreational activities (Mansuroglu, 2002).

In the most general and most understandable way, recreation can be defined as activities carried out in "leisure time" outside working hours. As people perform recreational activities, they become aware of their potential and also satisfy the need for self-realization in Maslow's hierarchy of needs (Figure 1). This is because recreation allows individuals to discover themselves and develop their potential (Sevil, 2012).

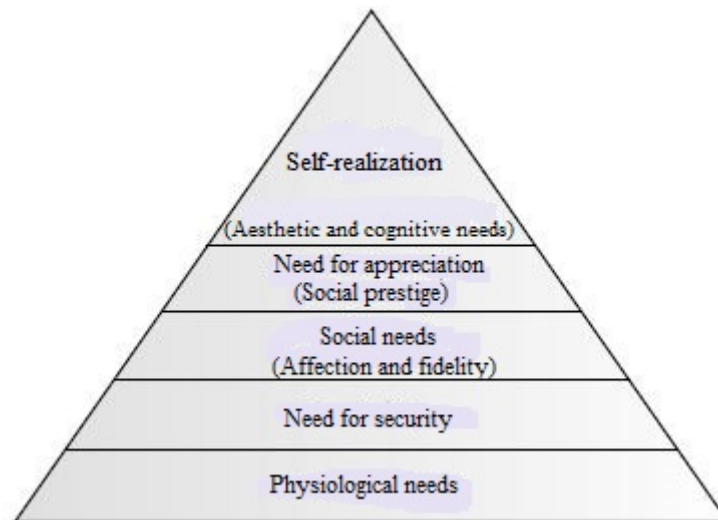


Figure 1. Maslow's hierarchy of needs (Bourdurst, 2001, Cited by Sevil, 2012).

Recreational activities vary according to age, sex, time, place, and are influenced and varied by many factors (Kaya, 2016). Individuals' preferences and satisfaction levels are also among the factors that cause the diversification of these activities (Uzun, Muderrisoglu, & Akinci Kesim, 2005). In order to

perform all these activities, the most essential condition is that the individual has the time to perform these activities (Kilicaslan, 2008; Tutuncu et al., 2011).

According to Kraus (1998), the concept of leisure time, which includes the concept of free time in the definition of recreation, is defined as the time apart from the time spent on sleeping, compulsory activities and work. Free time is, on the other hand, the time left after the individual has carried out his/her domestic, communal or professional duties that must be carried out to continue one's life (Sevil, 2012).

As Nixon (1969) and Guler (1978) mentioned, the working capacity is as important for an individual as the time he/she can spare for him/herself (Sevil, 2012). In order for the working efficiency of an individual to increase; it is necessary for the individual to have time to feel free and to complete himself in this way (Yerlisu Lapa, 2013; Karakucuk, 2014).

The concept of leisure time includes the concept of recreation. According to Karakucuk (1999); recreational activities can only be carried out in leisure time (Sevil, 2012). According to Aktas (2008); recreation is the whole of the activities that increase the quality of life of individuals and that individuals enjoy doing without harming any natural or cultural values (Kalayci & Uzun, 2015).

Recreation can be divided into 6 classes. These classes and their descriptive properties are given in table 1.

**Table 1.** Types of recreation (adapted from Sevil, 2012)

RECREATION TYPES		DESCRIPTIVE PROPERTIES
According to the Participation in the Activities	Active	Active, Dynamic Activities
	Passive	Watching, Being an Audience
According to Local Classification	Urban	Within urban boundaries
	Rural	Outside the City Center
In terms of Space	Outdoors	Outdoors
	Indoors	Indoors
According to the Number of Participants	Individual	Single
	Group	As a Community
In terms of Function	Commercial	Presented by Institutions and Organizations
	Social	Performed for Socialization
	Aesthetics	Visiting exhibitions, listening to music
	Intellectual	Passive Activities for Learning and Intellectual Development
In terms of Time	Every day	In the neighborhood, Short Termed
	Holiday	Activities performed in Holidays, Festivals etc.
	Variable	Activities that Retired People Do

There are many factors that affect the ability of individuals to participate in recreational activities. The most significant of these factors are time and material opportunities.

Like many undergraduate programs where the applied courses dominate, undergraduate students of the Department of Landscape Architecture suffer from both temporal and material difficulties because of the way the courses are taught and the obligations. For this reason, the recreational habits of the students and the factors affecting these habits vary. Within the scope of this study, the recreational activity habits of undergraduate students of Landscape Architecture Department of Kastamonu University were examined and the factors that are effective were evaluated statistically.

## 2. Method

Undergraduate education is classified as undergraduate 1 (15), undergraduate 2 (15), undergraduate 3 (15), undergraduate 4 (16). It was determined according to Ozdamar (2003) that as the universe of the

## Recreational Activity Habits of Undergraduate Students and Factors Affecting Their Habits

study is the 163 students at the Department of Landscape Architecture of Kastamonu University; there was a need for 61 questionnaires with 10% of error margin, 95% of confidence level. A questionnaire was conducted with 61 participants and a chi square analysis in the SPSS 20.0 package program was conducted to the data from the first part of the questionnaire. In the chi square analysis, time allocated to recreation according to gender and educational status, which activities come to mind when speaking about recreation, and the reasons for performing recreational activities and the frequency with which participants performed recreational activities were investigated.

In the second phase of the study, the participants were asked a question of 25 proposals in a 4-point Likert scale. They were asked to respond to the question between 0 and 3 (No idea- Disagree- Neither Disagree nor Agree- Agree).

For the evaluation of this part of the questionnaire, firstly, correlation analysis was performed in the SPSS 20.0 package program in order to reveal the relation between education levels.

In the next step; it was revealed which of the Likert scale the proposals evaluated in the Likert-scale got close to on average.

### 3. Findings

To ensure gender balance among the participants, 31 female students and 30 male students were selected.

Of the participants, 15 live with home mates, 6 with their family, 37 at dorm and 3 live with their relatives.

Participants were grouped in 3 groups according to their income source types: 30 received scholarships/credits, 11 were employed in a job and 20 received financial support from their families. According to the amount of income, the participants were grouped in the following way: 12 people less than 500 TL, 29 people between 501-1000 TL, 12 people between 1001 - 1500 TL and 8 people more than 1501 TL.

Of the participants, 15 stated that; they did not spend any time to recreational activities; 35, 1 or 2 times a week; 6, 3 or 5 times a week; and 5, everyday.

To the question about the reasons for recreational activities, the option for fun was opted by 54 participants, for relaxation by 55, for spending time with friends by 51; for excitement by 27; for health by 32; for sports by 36; for spending time with family by 34; for being alone by 36; for being alone with the nature by 55; for working off energy by 29 participants. The option 'for relaxation' opted by 55 participants was the one opted the most. The least opted option was, on the other hand, the option 'for excitement' which was opted by 27 participants. To the question which recreational activities the participants preferred; 49 participants responded as going for a walk in the park/woods; 43 cycling, 24 skateboarding/skating, 38 playing ball games, 35 photography, 17 bird watching , 31 trekking , 15 canyoning, 34 camping, 17 visiting caves, 28 visiting museums-ruins. The option that was least opted was canyoning whereas going for a walk in the park/woods was the most opted option. Participants also think that the activities of playing with painting boxes and dancing are also recreational activities besides the options given in the questionnaire. In the context of the analyzes made, a square analysis was conducted to determine the relationship between education, gender, amount of income, income source and frequency, and what activities come to the minds of participants when talking about recreational activities (Table 2).

**Table 2.** Significant differences between recreational activities and other factors

RECREATIONAL ACTIVITIES	Gender	Education	Amount of Income		
			Income	Source	Frequency
Skating-Skateboarding	0.012	0.008			0.011
Trekking		0.044			
Visiting museum-ruins		0.006		0.009	0.003
Going for a walk in the park/woods			0.048		0.006
Cycling			0.033		
Canyoning			0.004		
Bird watching				0.006	
Camping				0.002	

There was a significant difference only in the "Skating-Skateboarding" option according to gender. 45.2% of females and 76.7% of males do not think of "Skating-Skateboarding" as recreational activities.

Significant differences were found in "Skating-Skateboarding", "Trekking", "Visiting Museums-Ruins" activities according to educational level. 26% of the first graders, 66.7% of the second graders, 53.3% of the third graders and 12.5% of the fourth graders selected the "Skating-Skateboarding" activity whereas 40% of the first graders 26.7% of the second graders, 73.3% of the third graders and 62.5% of the fourth graders selected the "Trekking" activity. 26.7% of the first and second graders, 46.7% of the third graders and 81.2% of the fourth graders regarded "Visiting Museum-ruins" as a recreational activity.

When the recreational activities are analyzed according to the amount of income; there was a significant difference in the "Going for a walk in the Park/ Woods", "Cycling" and "Canyoning" options. Significant differences were found in "Visiting Museums-ruins", "Bird watching" and "Camping" options according to income source.

There was a significant difference in the "Skating-Skateboarding", "Visiting Museums-ruins", "Going for a walk in the Park/ Woods" options according to the frequency with which the participants spared time to the recreational activities. It was determined that as the frequency increased, the preference rate of "Going for a Walk in the Park/ Woods" option decreased. The "Skating-Skateboarding" option is preferred by 83% of participants who perform 2-3 or more recreational activities per week whereas "Visiting Museums-ruins" option is less preferred as the frequency of recreational activities increased. Subsequently, a chi-square analysis was conducted to determine the relationship between education, gender, amount of income, income source and frequency, and the reason why participants performed recreational activities (Table 3). There was no significant difference according to gender.

**Table 3.** Significant differences between reasons for recreational activities and other factors

Reason	Education	Amount of Income	Income Source	Frequency
For excitement	0.08	0.006		
For sports	0.02	0.041	0.003	0.038
For being in nature	0.039			
For working out energy	0.006			0.014
For being alone			0.005	
For fun				0.008
For health				0.049

## Recreational Activity Habits of Undergraduate Students and Factors Affecting Their Habits

When the relationship between the reasons for performing recreational activities and the level of education is analyzed, there was a significant difference in "for excitement", "for sports", "for being in nature" and "for working out energy" options. It was determined that the preference of "for being in nature" increased as the education level increased.

When the reasons for recreational activities are examined according to the amount of income, there was a significant difference in "for excitement" and "for sports" options.

When the reasons are examined by income sources, there was a significant difference in "for sports" and "for being alone" options. It was determined that 76.7% of the participants whose income source is "scholarship-credit" performed recreational activities for "sports" whereas only 18.2% of the participants who received incomes from working in a job preferred the "for sports" option.

When the options selected by the participants as the reason for performing recreational activities are examined according to the frequency with which they performed the activities, there was a significant difference in the "for sports", "for working out energy", "for fun" and "for health" options. As the frequency increased, the recreational activity was less performed "for fun". These 3 options, for which significant differences were found, were mostly performed "once or twice a week" by the participants. Correlation analysis indicated significant relation ( $p < 0.001$ ). According to Kendall's tau-b value; moderate correlation was found between undergraduate 1 and undergraduate 2 participants ( $r = 0.598$  coefficient value), between undergraduate 1 and undergraduate 3 participants ( $r = 0.617$  coefficient value) and between undergraduate 1 and undergraduate 4 participants ( $r = 0.608$  coefficient value) whereas a weak correlation was found between undergraduate 2 and undergraduate 4 participants ( $r = 0.447$  coefficient value) and undergraduate 3 and undergraduate 4 participants ( $r = 0.482$  coefficient value). This indicates that the difference between undergraduate 1 and other participants is greater whereas the difference between undergraduate 2 and 3 levels showed less difference with other grades. In the next step; it was revealed which of the Likert scale the proposals evaluated in the Likert-scale got close to on average. Since there was no score value of the participants who responded "no idea", these participants were excluded from the table 4 and the averages of the values given by the participants who had an idea were shown.

**Table 4.** The averages of the proposals in the Likert- type scale

		No idea	Num ber of Pers ons	Total Score	Approxi mate Averag e
1	Recreational activity makes the person happy.	6	56	164	2.93
2	Recreational activity is tiring.	3	58	91	1.57
3	Recreational activity is indispensable for a person.	6	56	106	1.89
4	I spare time for recreational activity only when I have free time.	1	60	155	2.59
5	Recreational activity is relaxing.	2	59	157	2.66
6	Recreational activity is a way of mental resting.	2	59	150	2.54
7	I allocate budget for recreational activity.	3	58	137	2.36
8	Recreational activity is performed with friends.	2	59	114	1.93
9	Recreational activity has an important place in my life.	5	56	128	2.29
10	Recreational activity is performed only at weekends.	5	56	66	1.17
11	Recreational activity can be performed without spending money as well.	4	57	150	2.63
12	Recreational activity is a lifestyle.	4	57	136	2.39
13	I have no time to perform any recreational activity.	3	58	111	1.91
14	I have no money to perform any recreational activity.	2	59	105	1.78
15	There are no places where I can perform recreational activities.	2	59	142	2.41
16	Recreational activity allows people to socialize.	0	61	170	2.79
17	Recreational activity psychologically comforts people.	2	59	170	2.88
18	Recreational activity is performed only outdoors.	3	58	99	1.71
19	Recreational activity can be performed indoors.	3	58	118	2.03
20	Recreational activity makes people active.	2	59	163	2.76
21	I spare time for recreational activities every day.	3	58	85	1.46
22	I spare time for recreational activities several times a week.	1	60	149	2.48
23	Transportation is important for recreational activity.	2	59	149	2.52
24	Season is important for recreational activity.	1	60	137	2.28
25	Distance is important for recreational activity.	0	61	151	2.47

According to Table 4, which emerged as a result of the evaluations of the participants, the following proposals with an average value approaching the "Agree" option with 2 (neither agree, nor disagree) and 3 (agree) stand out with an average of over 2.5:

- Recreational activity makes the person happy.
- I spare time for recreational activity only when I have free time.
- Recreational activity is relaxing.
- Recreational activity is a way of mental resting.
- Recreational activity can be performed without spending money as well.

## Recreational Activity Habits of Undergraduate Students and Factors Affecting Their Habits

- Recreational activity allows people to socialize.
- Recreational activity psychologically comforts people.
- Recreational activity makes people active.
- Transportation is important for recreational activity.

The following proposals with an average value approaching the "Disagree" option with 1 (disagree) and 2 (neither agree, nor disagree) stand out as the least selected proposals with an average of below 1.5:

- Recreational activity is performed only at weekends.
- I spare time for recreational activities every day.

As the last stage, the percentages of the Likert-scale responses of the participants according to their educational levels are given in table 5.

**Table 5.** Percentages of the responses on the Likert scale

	Undergraduate 1(%)				Undergraduate 2(%)				Undergraduate 3(%)				Undergraduate 4(%)			
	No idea	Disagree	Neither agree.	Agree	No idea	Disagree	Neither agree.	Agree	No idea	Disagree	Neither agree.	Agree	No idea	Disagree	Neither agree.	Agree
1	0,0	0,0	26,7	73,3	0	0,0	0,0	0	3	0,0	0,0	7	0,0	0,0	0,0	100,
2	0,0	7	20,0	13,3	3	0	0	6,7	6,7	0	6,7	26,7	0,0	56,3	31,3	12,5
3	0	7	7	26,7	3	13,3	33,3	0	6,7	20,0	7	26,7	0,0	68,8	18,8	12,5
4	6,7	6,7	40,0	46,7	0,0	33,3	6,7	0	0,0	13,3	13,3	3	0,0	0,0	0,0	0
5	0,0	0,0	13,3	86,7	3	0,0	20,0	7	0,0	0,0	40,0	0	0,0	12,5	31,3	56,3
6	6,7	13,3	26,7	53,3	6,7	13,3	33,3	7	0,0	0,0	20,0	0	0,0	0,0	43,8	56,3
7	0	20,0	26,7	33,3	0,0	13,3	40,0	7	0,0	20,0	20,0	0	0,0	0,0	0	50,0
8	0,0	26,7	0	33,3	3	13,3	26,7	7	0,0	40,0	13,3	7	0,0	68,8	31,3	0,0
9	6,7	26,7	3	33,3	6,7	6,7	26,7	0	6,7	6,7	33,3	3	5	18,8	0	18,8
10	6,7	7	0,0	6,7	3	7	6,7	13,3	3	7	20,0	0,0	0,0	0	0,0	0,0
11	6,7	0,0	6,7	86,7	0,0	20,0	26,7	3	0	26,7	13,3	0	0,0	0,0	0,0	0
12	0,0	13,3	33,3	53,3	0	13,3	26,7	0	6,7	40,0	0,0	3	0,0	0,0	37,5	62,5
13	0,0	33,3	3	13,3	3	7	26,7	13,3	6,7	0	0	13,3	0,0	18,8	18,8	62,5
14	13,	53,				46,				73,						
15	3	3	6,7	26,7	0,0	7	26,7	26,7	0,0	3	20,0	6,7	0,0	37,5	0,0	62,5
16	0,0	20,0	0	40,0	3	20,0	26,7	0	0,0	20,0	26,7	3	0,0	0,0	18,8	81,3
17	0,0	0,0	0,0	0	0,0	13,3	13,3	3	0,0	13,3	6,7	0	0,0	0,0	12,5	87,5



<b>1</b>					13,			<b>73,</b>				<b>93,</b>				<b>100,</b>
<b>7</b>	0,0	0,0	13,3	<b>86,7</b>	3	6,7	6,7	<b>3</b>	0,0	6,7	0,0	<b>3</b>	0,0	0,0	0,0	<b>0</b>
<b>1</b>			<b>40,</b>					<b>66,</b>		13,	<b>46,</b>					
<b>8</b>	6,7	26,7	<b>0</b>	26,7	0,0	7	13,3	20,0	3	7	20,0	20,0	0,0	<b>50,0</b>	37,5	12,5
<b>1</b>		<b>33,</b>	<b>33,</b>					<b>60,</b>		<b>46,</b>					<b>50,</b>	
<b>9</b>	6,7	<b>3</b>	<b>3</b>	26,7	6,7	26,7	6,7	<b>0</b>	6,7	7	26,7	20,0	0,0	18,8	<b>0</b>	31,3
<b>2</b>					13,			<b>66,</b>				<b>93,</b>				
<b>0</b>	0,0	0,0	20,0	<b>80,0</b>	3	6,7	13,3	7	0,0	6,7	0,0	<b>3</b>	0,0	0,0	31,3	<b>68,8</b>
<b>2</b>	13,	<b>60,</b>						<b>33,</b>	<b>33,</b>			<b>66,</b>				
<b>1</b>	3	<b>0</b>	26,7	0,0	6,7	<b>3</b>	<b>3</b>	26,7	0,0	7	26,7	6,7	0,0	<b>87,5</b>	0,0	12,5
<b>2</b>								<b>53,</b>				<b>66,</b>			<b>50,</b>	
<b>2</b>	0,0	13,3	13,3	<b>73,3</b>	6,7	26,7	13,3	<b>3</b>	0,0	13,3	20,0	<b>7</b>	0,0	0,0	<b>0</b>	<b>50,0</b>
<b>2</b>								<b>46,</b>				<b>60,</b>				
<b>3</b>	6,7	13,3	0,0	<b>80,0</b>	6,7	13,3	33,3	7	0,0	26,7	13,3	<b>0</b>	0,0	0,0	31,3	<b>68,8</b>
<b>2</b>			<b>46,</b>					<b>40,</b>				<b>46,</b>				
<b>4</b>	0,0	20,0	7	33,3	6,7	20,0	33,3	<b>0</b>	0,0	13,3	40,0	7	0,0	18,8	18,8	<b>62,5</b>
<b>2</b>								<b>53,</b>				<b>86,</b>				
<b>5</b>	0,0	26,7	20,0	<b>53,3</b>	0,0	20,0	26,7	<b>3</b>	0,0	0,0	13,3	7	0,0	18,8	18,8	<b>62,5</b>

When the percentage results are examined,

it can be seen that the proposal "recreational activity is indispensable for a person" was mostly agreed by undergraduate 2 students whereas mostly disagreed by undergraduate 4 students.

It can also be seen that the proposal "recreational activity is performed with friends" was mostly agreed by undergraduate 2 and undergraduate 3 students whereas undergraduate 4 students mostly disagreed with this proposal.

The participants were between "agree" and "disagree" responses for the "recreational activity has an important place in my life" proposal.

It was seen that undergraduate 1-2-3 students mostly disagreed and neither agreed nor disagreed with the "I have no time to perform recreational activities" and "I have no money to perform any recreational activity" whereas undergraduate 4 students mostly agreed.

While undergraduate 1 students mostly neither agreed nor disagreed with the "recreational activity is performed only outdoors" proposal, undergraduate 2-3-4 students mostly disagreed with this proposal. The proposal that "recreational activity can be realized indoors" changed according to each grade level whereas undergraduate 3 students mostly disagreed with this proposal.

Only undergraduate 1 students neither agreed nor disagreed with the "season is important for recreational activity" whereas other students mostly agreed with this proposal.

#### 4. Conclusion

In this study, the recreational activities of the students of the Department of Landscape Architecture of Kastamonu University and the factors affecting these activities were tried to be determined. Over the students selected as participants, it will be possible to obtain findings about the students of departments such as Landscape Architecture where applied courses dominate.

31 female and 30 male students were surveyed in the study as the sample. It was determined that these students mainly stayed in dorms. These students usually obtain income through scholarship - credit and approximately half of them receive an income between 501-1000 TL. Half of the participants spare time to recreational activities about once or twice a week.

Almost all of the participants perform recreational activities for relaxing and for being in nature. Most of the participants responded 'going for a walk in the park/ woods' to the question of what comes to their mind when speaking of recreational activity. There was not much difference in preferences according to gender, as expected. Participants' preferences for recreational activities vary according to their educational status. In particular, the option of visiting museums-ruins is more preferred as the

level of education increases. However, as the amount of time allocated to recreational activities increased; the option of visiting museums-ruins was selected at a minimum level. It is thought that this result is due to the fact that students think that it is sufficient to visit any museum-ruin once.

When the reasons why the participants performed recreational activities are examined; there was no significant difference in terms of gender. This result is parallel to the expected result. This is because the pleasure individuals get from recreational activities is not about gender but about individual preference. It is seen that the number of participants who performed recreational activities in order to be in nature increases more as the level of education increases.

There was a significant correlation ( $p < 0.001$ ) between the participants in the correlation analysis according to their education levels. This suggests that whatever the level of education, there is a relationship between recreational habits and the factors that influence it.

When the proposals in the Likert scale are evaluated according to the percentage ratios, it was revealed as expected that recreational activities make the individual happy and active and allow them to relax, socialize and that transportation is important for these activities. Individuals are aware that they can perform recreational activities without paying any price. In addition, another proposal that was selected at a high level was that individuals can perform recreational activities when they have free time, which is also reflected in the definition of recreation.

The proposal that recreational activities can only be performed at weekends was also selected at a low level, which was also in line with the expectations.

Changes according to the education level in the proposals are an indication that the higher the education level, the better the understanding of the concept of recreation. However, the proposals 'I have no money-time to perform any recreational activities- were mostly preferred by undergraduate 4 participants. The reason for this is believed to be the fact that the participants have heavy applied courses and have to spend a lot of money for these courses in order to meet the requirements for graduation. The proposal that 'recreational activity is indispensable for a person' was increasingly less preferred as the grade level increased.

The reason for this is thought to be the fact that participants who spend a full academic year without sparing time to recreational activities are at this level of education.

In the light of all these results, it can be concluded that young people who make up the participant group do not manage their time very well and they are not aware of the fact that the place they can learn time-management best is the university. In the departments such as Landscape Architecture, Architecture, City and Regional Planning, Interior Architecture where applied courses dominate -and as in all the other departments- , it should not be forgotten that students should have an efficient education life as well as graduate as healthy individuals and get jobs as citizens beneficial to the whole society. In this regard, a big responsibility falls on the shoulders of academicians. It is necessary that students should be given support about the recreational activities through which they can self-actualize and that recreational activities should be made more attractive for them through, if necessary, showing them different activities than the usual ones. Most importantly, students should be supported on time management and they should be taught that if they can make an efficient planning, they will have time to spare to anything they want. It should not be forgotten that students who are conscious about programmed life style will be better and more qualified individuals in the society.

## 5. Acknowledgment

We would like to thank TUBITAK 2229 project titled "Analytic Nature-Clustering and Ordination Techniques" for the methods used in this study.

## 6. References

- Ayyildiz Durhan, T., Akgul, B. M., & Karakucuk, S. (2017). Rekreatif Amacli Yuzme Sporuyla Ugrasan Bireylerin Bos Zaman Yonetimleri Uzerine Bir Degerlendirme. *Ataturk Universitesi Beden Egitimi ve Spor Bilimleri Dergisi*, Cilt: 19 (4) : 8-16.
- Ergul, K., Alp, H., & Camliyer, H. (2015). Determination of the Interest and Participation Level for the Youth of University Sports Recreation Activities. *Journal of Tourism Theory and Research*, Volume: 1(2) : 76-83.
- Gungor, S., Cengiz, T. (2006). Artvin Ilinin Iklim Konforuna Sahip Rekreasyon ve Turizm Alanlari. *Kafkas Universitesi Artvin Orman Fakultesi Dergisi*, 7(1): 69-80
- Gungormus, A. H., Yetim, A. A., & Calik, C. (2006). Ankara'daki Beden Egitimi Ve Spor Yuksekokullarinda Gorev Yapan Ogretim Elemanlarinin Bos Zamanlarini Degerlendirme Bicimlerinin Arastirilmesi. *Kastamonu Egitim Dergisi*, Cilt:14(1) : 285-298.
- Huang, C.Y., & Carleton, B. (2003). The Relationships among Leisure Participation, Leisure Satisfaction, and Life Satisfaction of College Students in Taiwan. *Journal of Exercise Science and Fitness*, 1(2): 129-132.
- Kalayci, M., & Uzun,O. (2015). Maden Alanlari Peyzaj Onarim Calismalari ve Bazi Rekreasyonel Aktiviteler. *III. Rekreasyon Arastirmalari Kongresi Bildiri Kitabi*, s: 369-378, Eskisehir.
- Karakucuk, S. (2014). Rekreasyon Bos Zamanlari Degerlendirme, s: 30, Bagirgan Yayınevi, Ankara.
- Kaya, S. (2016). The Relationship between Leisure Satisfaction and Happiness among College Students. *Universal Journal of Educational Research* 4(3): 622-631.
- Kilicaslan, C. (2008). Ortaca Kenti Rekreasyon Alanlarının Mevcut Durumu ve Mugla Universitesi Ortaca Meslek Yuksekokulu Ogrencilerinin Rekreasyon Alanlarına Yonelik Beklentileri. *Duzce Universitesi Ormancilik Dergisi*, Cilt: 4(1-2) : 3-16.
- Mansuroglu, S. (2002). Akdeniz Universitesi Ogrencilerinin Serbest Zaman Ozellikleri ve Dis Mekan Rekreasyon Egilimlerinin Belirlenmesi. *Akdeniz Universitesi Ziraat Fakultesi Dergisi*, 15(2) : 53-62.
- Onder, S. (2003). Selcuk Universitesi Ogrencilerinin Rekreasyonel Egilim ve Taleplerinin Belirlenmesi Uzerinde Bir Arastirma, *Selcuk Universitesi Ziraat Fakultesi Dergisi*. 17 (32): 31-38.
- Ozdamar, K. (2003). Modern bilimsel arastirma yontemleri. s: 116-118. Kaan Kitabevi, Eskisehir.
- Sevil, T. (2012). Bos Zaman ve Rekreasyon Yonetimi, Anadolu Universitesi Yayin No:2497, Eskisehir.
- Tel, M., & Koksalan, B. (2008). Ogretim Uyelerinin Spor Etkinliklerinin Sosyolojik Olarak Incelenmesi (Dogu Anadolu Ornegi). *Firat Universitesi Sosyal Bilimler Dergisi*, 18(1) : 261-278.
- Tutuncu, O., Aydin, I., Kucukusta, D., Avci, N., & Tas, I. (2011). Universite Ogrencilerinin Rekreasyon Faaliyetlerine Katilimini Etkileyen Unsurlarin Analizi. *Hacettepe Journal of Sport Sciences*, 22 (2), s: 69-83.
- Uzun, S., Muderrisoglu, H., & Akinci Kesim, G. (2005). Kentsel Alanlardaki Parklarda Kullanici Memnuniyeti: Duzce Inonu Parki Ornegi. *Abant Izzet Baysal Universitesi Ormancilik Dergisi*, 1(2) : 111-124.
- Yerlisu Lapa, T. (2013). Life Satisfaction, Leisure Satisfaction and Perceived Freedom of Park Recreation Participants. *Procedia - Social and Behavioral Sciences* (93): 1985-1993.

# Factors that Affect the Learning Process

Kadri Krasniqi

## **Introduction**

Human beings, despite being considered one of the cleverest and toughest creatures in the world, can still be very sensitive, and can be affected a great deal when exposed to various internal and external factors. Such factors that affect the learning process are of various types and include the following: intellectual, learning, physical, psychological, emotional and social, economic, environmental, and even a teacher's personality. Furthermore, there may be other factors which are, as yet, not known to us but which will significantly affect the learning process. Some of these factors that affect our learning process could be improved or eased with the help of adaptable therapies or reinforced practices. However, there may be a lot of other factors that cannot be improved or lessened by any kind of adaptable therapies or reinforced practices due to their complex nature. It has been discovered and confirmed that a pupil's difficulties in learning may be due to factors within the child himself/herself.

Different children have different approaches to learning, retaining, and processing information. Children learn how to identify objects at an early age; teenagers learn how to improve study habits and adults learn how to solve complex problems. Indeed, this applies to everyone throughout their long life learning process. The purpose of this research paper is to identify and elaborate on some of the main factors that affect the learning process of children.

## ***Some of the main factors that affect the learning process***

Since the beginning of human existence children and students have been acquiring knowledge and skill; but along the way, such acquisition will have been affected by many internal and external factors associated with the learning process. Abucay (2009) states that a pupil's difficulty in learning may be due to different factors which include the following: intellectual factors, learning factors, physical factors, emotional and social factors, mental factors, environmental factors and even teacher's personality. Some of these factors will affect a child's learning to a greater or lesser extent.

This research paper will elaborate on some of the most influential factors that affect the learning process, such as:

## **Intellectual factor**

This term refers to the individual way that pupils learn. It also refers to the individual mental level of pupils. In other words, it is about how pupils or students organize their minds ... their ideas as well as how they combine their thoughts to make sense of the world they live in. Pupils learn in different ways, such as: by trial and error, by copying, by exploring, repeating, questioning, doing, experimenting, talking, playing, listening and looking.

According to Human Growth and Development (Intellectual Development 2012) the most important tools of intellectual development that affect a pupils' learning process are language and cognitive development. Language development helps pupils to organize their thoughts and make sense of the world around them. It also helps pupils ask questions and develop simple ideas into more complex ones. All pupils have a need to communicate and share ideas and language is the tool that allows this important process to happen. Whereas, cognitive development is about how pupils use their minds and organize their thinking in order to understand the world around them. Cognitive development also involves imagination; allowing pupils to picture things that are not in front of them. It also includes problem solving skills thus enabling pupils to solve problems by following a set of patterns or sub-processes such as: identifying the problem, working out the solution, and predicting what might happen next.

According to Abucay (2009) intellectual factors can also include reaction to being praised in school and is generally related to the intellectual level of a pupil. In most cases, pupils with low level of intellect encounter serious difficulty in mastering or improving their schoolwork; similar observations would be noticed to workers with low intelligence who would encounter difficulty in mastering their work duties and improving on their performance.

### **Learning factor**

According to Lucas and Corpuz (2007), learning or thinking styles refer to the preferred way an individual processes information and also describe a person's typical mode of thinking, remembering or problem solving. There are several learning or thinking styles that can affect a pupils' learning process. Visual learners are those pupils who jockey for the positions at the front of the class. They must have front row class or theatre seats and love to be close to the action for sporting events in order to obtain the best view (Ldpride.net, 2008). Auditory learners are those pupils who are very good listeners. They tend to absorb information in a more efficient manner through sounds, music and discussion. These pupils will be more likely to record lectures so that they can replay them at a later time for study purposes. Auditory learners do not like or prefer written reports but tend to do better on oral presentations and reports (Ldpride.net, 2008). Kinesthetic learners are those pupils or students who are tactile learners. This means that they learn best through moving, doing, acting out and touching. Kinesthetic learners tend to become frustrated when they must sit for long periods of time. They enjoy conducting experiments, exploring and performing tasks (Ldpride.net, 2008).

In addition this is one of the factors that refer to lack of mastery of what has been taught, faulty methods of study, and lack of or narrowness of experimental backgrounds which may affect the learning process of many pupils or students. This is as a result when schools proceed too rapidly and do not have regular or constant checks on the extent to which pupils are mastering what they have been taught; whether the instructions are appropriate or faulty and whether the children may have learned inefficient methods of study. Therefore, pupils accumulate a number of problems / deficiencies that affect or interfere with their school or academic progress.

### **Physical factor**

We all know that learning is one of the most important aspects in a person's life; allowing them the ability or give them the opportunity to make informed choices when required. Unfortunately, there are a number of factors that can affect/impede the learning process; ranging from health, physical development, nutrition, visual and physical defects. Impaired vision is one of the most crucial detriments to the learning process. According to the website 'All About Vision', almost 80 percent of information pupils learn during school is presented to them visually. If undetected and uncorrected, vision problems can lead to learning problems. Impaired hearing can reduce a pupil's ability to learn in a classroom setting, for a simple reason that a pupil may not be able to accurately hear the teacher or their peers. If this occurs, the pupil will fall behind the rest of the class. This could lead to an ever-growing gap in issues such as vocabulary skills, sentence comprehension and sentence construction. As a result, many hearing-impaired pupils will pretend to understand what is being taught and perhaps leave the teacher with the false impression that the pupil fully comprehends the material or information. Nutrition fundamentally affects the learning process for the simple reason that a pupil who turns up to school hungry is not able to function to the best of his/her abilities. According to the website 'Public School Review', much of the food available to America's state schools may actually be negatively affecting a pupil's ability to learn, because of the food containing large quantities of sugar, caffeine, sodium and assorted chemicals that leave pupils feeling "tired, unfocused, jittery and sick," which will in turn affect their learning process. Fatigue also has a crucial effect on learning. In particular sleep deprivation has an undeniable negative impact on a pupil's ability to perform or learn. In addition, fatigue brings problems with long-term and short-term memory and makes it difficult to retain information that has been learnt.

## Factors that Affect the Learning Process

Above all, it has been researched and generally confirmed that ill health delays both physical and mental development, and that malnutrition interferes with the learning process and physical growth.

### **Mental factors**

These particular factors refer to thoughts, feelings and other cognitive characteristics that affect the behavior, attitude, and other non-physical functionality of pupils. They are made up of organic and kinesthetic elements, and importantly contribute to the development of a pupils' personality. These factors should not be confused with emotions that are generally characterized by internal visceral disturbances, and affect a large proportion of pupils around the World.

Mental factors play a significant part in the cognitive organization and general behavior of pupils. Apart from exercising an effect upon the rate of learning, attitude also exercises an effect upon the rate of teaching, and impacts on the progress in school. In this context (Mondal, 2016) confirms, "The efficiency of the work from day to day and the rapidity with which it is achieved are influenced by the attitude of the learner and is closely related with the symbolic drive and reward nature." On the one hand, we all know that from our own experience in teaching that a favorable mental attitude facilitates learning and contributes continuous progress over time. On the other hand, according to (Papaioannou, 2016), "The teaching process, which involves designing, preparing and coordinating a given class, must be at the level that will generate accurate predictions for the outcome of teaching and integrate the widest possible range of psychological aspects to the benefit of all participants involved in learning." However, mental factors can influence how a pupil thinks and also affect his/her decisions and relations in his/her daily life.

### **Emotional and social factors**

This is one of the most sensitive areas that affect the learning process. They refer to personal factors, such as instinct and emotions, and social factors such as cooperation and rivalry that are directly related to a complex psychology of motivation. According to (Desautels, 2016), "We are neurobiological wired, and to learn anything, our minds must be focused and our emotions need to "feel" in balance. Emotional regulation is necessary so that we can remember, retrieve, transfer, and connect all new information to what we already know."

However, it has been recognized and confirmed by many psychologist and educators that the various responses of the pupil to various kinds of stimuli are determined by a large number of tendencies. On one hand, some of these innate tendencies are constructive and lead to continuous progress and excellent achievement. On the other hand, some other tendencies are or could be undesirable and lead to some pupils developing a dislike for some subjects, as a result of failing to see its value or lacking foundation. This tendency, in most cases, results in a negative emotional state. However, some pupils are in a continuing state of unhappiness due to the fear of either being a victim of the disapproval of their teachers, parents or their classmates. This state of unhappiness and the fear of being a victim affect the learning process to a considerable degree and should be taken into consideration by any class teacher. So this leads us to the next factor that affects the learning process which is the teacher's personality.

### **Teacher's personality**

A teacher's personality can be the key to the learning environment and plays an important part or element in the failures and success of pupils. The teacher is also the most important factor in education process associated with teaching activities. The interaction of the teacher's personality with the personalities of the pupils being taught can prompt and determine the kind of behavior that emerges from the learning environment or situation.

We all know that the value of a teacher is not just the regular and appropriate performance of routine duties, but his/her will and influence to lead as an example and to inspire pupils through the influence of his or her moral personality. Therefore, a teacher's personality is made up of various factors which are the complex pattern of characteristics that distinguishes him or her from his colleagues or the groups of his kind. In other words, (Mondal, 2014) describes that, ".... an individual's personality is

a composite of his physical appearance, his mental capacity, his emotional behavior, and his or her attitudes towards others. Effective teaching and learning are the results of an integrated personality of the teacher.”

We all are aware from our own experiences in teaching that pupils do not like a grouchy teacher who cannot control his/her temper in the classroom. It is difficult for a grouchy teacher to create friendly and productive enthusiasm and to have any kind of positive influence to his/her pupils. Above all, pupils appreciate to have a happy, sympathetic, enthusiastic, and cheerful teacher... a teacher who is always there for his/her pupils and who is able to listen and empathize with them. So, effective teaching and learning is the product of love and care for the pupils, empathy for their interests, tolerance of their frustrations and a capacity for understanding. A teacher who lacks any of those characteristics will have a negative effect on the behavior exhibited within the learning environment.

### **Environmental factors**

Environmental factors refer to the physical conditions in which learning takes place - and affect the efficiency of learning in particular. Relevant environments include classrooms, textbooks, equipment, school supplies, and many other instructional materials (Mondal, 2014). The learning process is also affected by more general physical conditions at school such as large class sizes, insufficient ventilation, improper lighting, uncomfortable temperature, and noisy surroundings. Furthermore, the learning can be affected by factors within the home; e.g. the influence of family size, noise in the home (the use of radio and TV), etc. However, according to many scientists, environment is more important to a pupil's success than genetics. This is great news for all of us involved in teaching, because whilst we cannot control genetics we can make a difference by having some control over the environment.

Therefore, if we want our teaching to produce the desired results, then the conditions for learning must be favorable and adequate both in the school and at home. It has been emphasized by many educational psychologists and cannot be denied that the type and quality of instructional material and equipment in the school play an important part in the instructional efficiency of the school. Otherwise, it is so hard and difficult to do a good job of teaching in an inadequate type of building and without adequate/appropriate equipment and instructional materials. As a result, when building a school building or a classroom we have to consider the educational objectives and functions.

### **Conclusion**

All the factors mentioned and elaborated above affect the learning process in different ways. Among all factors, physical and environmental factors can greatly affect the learning process of children. However when compared to physical factors, environmental factors have a greater impact when it comes to children's learning. Environmental factors including the type and quality of instructional materials and equipment play an important role in the efficiency of the school's instructions (Abucay, 2009).

In addition, due to rise of poverty levels, too many children or students are turning up at school hungry, poorly dressed and above all unfit to study. As a result, they are not able to concentrate properly because they have not eaten, in some cases for days, and are either tired or stressed (Harris, 2011).

Finally, the lack of interest shown among some pupils indicates a weakness (unable to be identified) on the part of the school system to make education more interesting for them. This may be due to several issues such as: poor teaching quality, inadequate facilities and resources, and probably poor infrastructure (Sisante, 2008).

### **References**

Abucay A.R. (2009). Factors that may affect the learning process. Retrieved on the 17<sup>th</sup> of June, 2017 from, <http://www.infosforyouandme.com/2009/04/factors-that-may-affect-learning.html>

Brent, M. Physical factors that affect learning. Retrieved on the 12<sup>th</sup> of June, 2017 from the ehow.co.uk, [http://www.ewh.co.uk/info\\_8210852\\_physical-factors-affect-learning.html](http://www.ewh.co.uk/info_8210852_physical-factors-affect-learning.html)

## Factors that Affect the Learning Process

Desautels, L. (2016). How emotions affect learning, behaviors, and relationships. Retrieved on the 14<sup>th</sup> of June, 2017 from the edutopia.org, <https://www.edutopia.org/blog/emotions-affect-learning-behavior-relationships-lori-desautels>

Environmental factors that influence learning, (2015). Retrieved on the 15<sup>th</sup> of June, 2017 from the Adams Educational Consulting website,

<http://www.effectiveteachingpd.com/blog/2015/9/22/environmental-factors-that-influence-learning>

Factors that affect individual learning, (2014). Retrieved on the 06<sup>th</sup> of June, 2017 from the Ministry of Education Guyana, <http://www.education.gov.gy/web/index.php/teachers/tips-for-teaching/item/1172-factors-that-affect-individual-learning>

Harris, S. (2011). Children are arriving in class too hungry and tired to concentrate, warns teachers' union. London, England: Associated Newspapers Ltd. Retrieved on the 16<sup>th</sup> of June, 2017 from, <http://www.dailymail.co.uk/news/article-1377028/Hungry-childrenconcentrate-warns-Association-Teachers-Lecturers.html>

Human growth and development, (2012). Retrieved on the 12<sup>th</sup> of June, 2017 from the Health, Social Care and Children's Services, [http://resources.hwb.wales.gov.uk/VTC/2012-13/22032013/hsc/eng/unit\\_2/hsc\\_u2\\_hgd/hsc\\_u2\\_intellectual-dev.htm](http://resources.hwb.wales.gov.uk/VTC/2012-13/22032013/hsc/eng/unit_2/hsc_u2_hgd/hsc_u2_intellectual-dev.htm)

Important factors affecting learning, (2017). Retrieved on the 05<sup>th</sup> of June, 2017 from the Med-Health.net, <http://www.med-health.net/Factors-Affecting-Learning.html>

Jain, T. (2011). How environmental factors affect our learning process. Retrieved on the 16<sup>th</sup> of June, 2017 from preservearticles.com, <http://www.preservearticles.com/2011082912251/how-environmental-factors-affects-our-learning-process.html>

Ldpride.net (2008). Understanding your learning styles. Retrieved on the 12<sup>th</sup> of June, 2017 from, <http://www.roe11.k12.il.us/GES%20Stuff/Day%203/Understanding%20Your%20Learning%20Styles.pdf>

Lucas, M. and Corpuz B. (2007). Facilitating Learning: a Metacognitive Process. 776 Aurora Blvd., cor. Boston Street, Cubao, Quezon City, Metro Manila: Lorimar Publishing, Inc.

Mondal, P. Important factors that may affect the learning process. Retrieved on the 05<sup>th</sup> of June, 2017 from the, <http://www.yourarticlelibrary.com/learning/7-important-factors-that-may-affect-the-learning-process/6064/>

Papaioannou, E. (2016). Psychological aspects that affect the learning process. Retrieved on the 14<sup>th</sup> of June, 2017 from the edutopia.org, <https://www.edutopia.org/discussion/psychological-aspects-affect-learning-process>

Sisante, J. (2008). Poverty, hunger prevents Filipino kids from getting basic education. Retrieved on the 16<sup>th</sup> of June, 2017 from <http://www.gmanetwork.com/news/story/111257/news/specialreports/poverty-hungerprevent-filipino-kids-from-getting-basic-education>.





# **An Analysis of Pre-Service Music Teachers' Self-Efficacy Perceptions Regarding Their Piano Playing Performance**

Deniz Beste Cevik Kilic

## **1. Introduction**

Piano instruction is compulsory for all pre-service teachers during their undergraduate education in the institutions that provide professional music education. The piano is the greatest assistant of music teachers in music instruction since it has a wide range of sounds, enables students enjoy their education thanks to its rich repertory, is easy to use in polyphonic ear training and is categorized as a harmonic accompanying instrument. For all these reasons, piano instruction is a major branch of all instrument education (Ogan and Albuz, 2015). This increases the importance of the studies that focus on improving pre-service music teachers' performances in music education (Fink, 1992). According to Tural (2015), in the process of teaching piano, the individual who is trained must do planned and regular work from the beginning. Work done should contribute to the learner's instrumental and musical development. The student should be able to use basic music knowledge effectively on the instrument while doing these exercises, and be prepared physically and psychologically (pp.346).

An effective piano performance is built on a complex structure that involves both musical and technical difficulties (Kurteva, 1987). In addition to the musical and technical difficulties, students' competence belief in their piano playing skills and self-confidence affect their piano performances. It is certain that pre-service music teachers' piano playing skills, self-confidence and self-efficacy involve their piano instructors, piano practice environment, the time they spare for their piano practices and the materials they use in lessons (Ozen, 1998).

Students' piano performance self-efficacy is revealed by how sufficient they perceive their piano performances. Hence, this study aims to determine undergraduate level pre-service teachers' self-efficacy levels regarding their piano performances considering a number of variables. Its research questions are:

1. Is there a significant difference among pre-service music teachers' self-efficacy scores for their piano performances?
2. Is there a significant difference among pre-service music teachers' self-efficacy scores for their piano performances by gender?
3. Is there a significant difference among pre-service music teachers' self-efficacy scores for their piano performances by year of study?

## **2. Methodology**

### **2. 1. Study Sample**

The sample of the study included 130 students in the Music Teaching Program of Fine Arts Teaching Department in Balikesir University's Necatibey Education Faculty in the 2016-2017 academic year. Of the participants, 79 were females, and 51 were males.

### **2. 2. Data Collection Tools**

The survey form that was used in the study has two sections. The first section inquires about the participants' gender and year of study. The second section includes the Piano Performance Self-efficacy Scale that was created by Gun and Yildiz (2014) for pre-service music teachers. This scale has 25 items and three sub-dimensions. Its sub-dimensions are technical level perception, stage anxiety perception and level perception. It is a 5-point Likert type scale with the responses: Strongly agree, partially agree, neither agree nor disagree, partially disagree and strongly disagree. The positive items

were scored in a linear manner, and the negative items are scored in an inverted manner. The analysis that were conducted for the scale found that the Kaiser-Meyer-Olkin (KMO) value was 0.941, and the result of the Bartlett's test was 2721,651 ( $p=.00$ ). The Cronbach's alpha value of the scale was .95, which indicated that the tool was reliable. Its reliability in this study was .89.

### 2. 3. Data Analysis

This study calculated descriptive statistics to evaluate the study data. Means and standard deviations were calculated in general and on a factorial basis to determine the students' piano performance self-efficacy levels. The Kruskal-Wallis test and t-test were calculated to determine whether the participants' scores varied significantly by gender and year of study.

### 3. Findings

#### The Findings for the First Sub-objective of the Study

The first research question of the study was: "Is there a significant difference among pre-service music teachers' self-efficacy scores for their piano performances?" The distribution of the scores is shown in Table 1.

**Table 1.** The arithmetic means and standard deviation values for pre-service music teachers' piano performance self-efficacy scores

Dimension	N	$\bar{X}$	SD
Technical Level Perception (Factor 1)	130	2.57	.68
Stage Anxiety Perception (Factor 2)	130	3.21	.83
Performance Level Perception (Factor 3)	130	3.64	.91
Total Scale	130	3.18	.74

As Table 1 shows, the pre-service teachers had moderate self-efficacy scores in piano performances ( $\bar{X}=3.18$ ,  $SD=.74$ ). On a factorial basis, their scores on factor 2 ( $\bar{X}=3.21$ ,  $S=.83$ ) and factor 1 were moderate ( $\bar{X}=2.57$ ,  $SD=.68$ ), while they obtained high scores on factor 3 ( $\bar{X}=3.64$ ,  $SD=.91$ ).

#### The Findings for the Second Sub-objective of the Study

The second research question of the study was: "Is there a significant difference among pre-service music teachers' self-efficacy scores for their piano performances by gender?" The distribution of the scores is shown in Table 2.

**Table 2.** The t-test results of the pre-service music teachers' piano performance self-efficacy levels by gender

Gender	N	$\bar{X}$	S	sd	t	p
Female	79	2.86	.51	.78	.64	.02
Male	51	2.74	.73			

As Table 2 shows, there is a statistically significant difference by gender in the students' piano performance self-efficacy scores ( $t=.64$ ,  $p<.05$ ) and a statistically significant difference between the piano performance self-efficacy scores of the females ( $\bar{X}=2.86$ ,  $S=.51$ ) and the males ( $\bar{X}=2.74$ ,  $S=.73$ ).

### The Findings for the Third Sub-objective of the Study

The third research question of the study was: "Is there a significant difference among pre-service music teachers' self-efficacy scores for their piano performances by year of study?" Table 3 shows the distribution for this research question.

**Table 3.** The Kruskal-Wallis test results of the pre-service music teachers' piano performance self-efficacy levels by year of study

Year of Study	N	Mean Rank	sd	$X^2$	p
1	32	35.24	3	6.24	.06
2	34	39.24			
3	28	29.59			
4	36	41.14			

There is no significant difference in the pre-service music teachers' piano performance self-efficacy scores by year of study [ $X^2(3)=6.24$ ,  $p>.05$ ]. The seniors had the highest scores ( $\bar{X}=41.14$ ), and the juniors had the lowest scores ( $\bar{X}=29.59$ ).

## 4. Discussion, Conclusion and Recommendations

There are a number of studies on self-efficacy belief, which is an important area of study in teacher training (Bandura, 1997; Caprara et al., 2006; Pajares, 1997; Zimmerman, 2000). Studies of self-efficacy are mostly included in the field of education. However, it has also been investigated in music, a major branch of fine arts. The belief of self-efficacy has an important part in music in relation to performance as well. A relevant study emphasizes that self-efficacy is the best reference for performance (McCormick and McPherson, 2006). Nielsen (2004) found that instrument and vocal music students had better self-efficacy and performances. That study also emphasized that participation in various musical activities during lessons affected students' self-efficacy beliefs and

performances. McCormick and McPherson (2006) emphasized the necessity of measuring self-efficacy in music, and also mentioned the importance of self-efficacy belief in instrument performance.

These studies have examined the concept of self-efficacy in music instruction in recent years, and it is very important that pre-service music teachers' self-efficacy levels in piano performance be studied. This study was intended to determine how students' piano performance self-efficacy levels vary by certain variables considering the lack of studies examining students' piano performance self-efficacy levels by particular variables.

The study found that the pre-service teachers' self-efficacy levels in piano performance were moderate. The pre-service teachers' technical skills and stage anxiety were moderate, and their performance level was high. The results related to stage anxiety indicated that the pre-service teachers were anxious about their stage performances and did not have sufficient experience with stage performance. The technical level sub-dimension is related to the fact that lesson subjects vary by students' levels. Pre-service teachers' high self-efficacy in piano performance shows that they are self-confident and have awareness about improving their performances.

Another finding of the study was that the piano performance self-efficacy levels of the pre-service teachers had a statistically significant difference by gender. Considering the arithmetic means of both groups, the arithmetic means of the females were statistically higher than those of the males. This finding is consistent with the relevant studies (Altuncekic et al., 2005; Cheung, 2008; Cevik, 2010; Cevik, 2011; Egilmez, 2015; McCormick and McPherson, 2006).

Another finding of the study showed that there was no statistically significant difference by year of study in the pre-service teachers' piano performance self-efficacy levels. Regarding the mean rank of their years of study, the seniors had the highest scores, and the juniors had the lowest scores. The fact that the senior students had higher self-efficacy levels in piano performance may be a natural result of the fact that they have had more education. The relevant studies are consistent with this finding (Egilmez, 2015; Gun and Yildiz, 2014).

Based on the findings, the study suggests that:

- Pre-service music teachers should participate actively in more concerts and auditions where they can perform.
- Further studies should be conducted to reveal the positive and negative factors that affect pre-service music teachers' self-efficacy in piano performance.
- Pre-service music teachers' opinions about their own self-efficacy levels in piano performance should be determined by holding semi-structured interviews.
- Future studies should be conducted to see whether pre-service music teachers' piano performance self-efficacy levels vary by demographic characteristics.

## 5. References

- Altuncekic, A., Yaman, S., & Koray, O. (2005). Ogretmen adaylarinin ozyeterlik inanc duzeyleri ve problem cozme becerileri uzerine bir arastirma (Kastamonu Ili Ornegi). *Kastamonu Egitim Dergisi*, 13 (1), 93-102.
- Bandura, A. (1997). *Self-efficacy. The exercise of control*. New York: W. H. Freeman and Company.
- Caprara, G. V., Barbaranelli, C., Steca, P., & Malone, P. S. (2006). Teachers' self efficacy beliefs as determinants of job satisfaction and students' academic achievement: A study at the school level. *Journal of School Psychology*, 44, 473-490.
- Cheung, Y. H. (2008). Teacher efficacy: A comparative study of Hong Kong and Shanghai primary in-service teachers. *Australian Educational Researcher*, 35 (4), 103-123.
- Cevik, D. B. (2010). *Muzik ogretmeni adaylarinin muzik ogretimi ozyeterlik duzeylerinin bazi degiskenler acisindan incelenmesi*, International Conference on New Trends in Education and Their Implications- ICONTE 2010, 11-13 Kasim, 2010. Antalya.
- Cevik, D. B. (2011). Sinif ogretmeni adaylarinin muzik ogretimi ozyeterlik duzeylerinin incelenmesi, *Ahi Evran Universitesi Egitim Fakultesi Dergisi*, 12 (1), 145-168.

## Pre-Service Music Teachers' Self-Efficacy Perceptions Regarding Their Piano Playing Performance

- Egilmez, H. O. (2015). Pre-Service music teachers' piano performance self-efficacy belief inversely related to musical performance anxiety levels. *Educational Research and Reviews*, 10 (18), 2558-2567.
- Fink, S. (1992). *Mastering piano technique*. Portland, Oregon: Amadeus Pres, pp. 4.
- Gun E., Yildiz, G. (2014). Muzik ogretmen adaylarina yonelik piyano performansi oz yeterlik olceginin gelistirilmesi. *Turkish Studies-International Periodical for the Languages, Literature and History of Turkish or Turkic*, 9 (5), 1053-1065.
- Kurteva, M. (1987). *Piyano ogretimi*. Sofya: Muzik Yayinlari.
- Mccormick, J., & Mcpherson, G. (2006). Self-efficacy and music performance. *Psychology of Music*, 34, 332-336.
- Nielsen, S. G. (2004). Strategies and self-efficacy beliefs in instrumental and vocal individual practice: A study of students in higher music education. *Psychology of Music*, 32 (4), 418-431.
- Ogan, F. D., & Albuz, A. (2015). Piyano Ogretiminde C. Czerny Op. 599 ve J.B. Duvernoy Op.176 Metodlarinda Yer Alan Etudlerin Klasik Donem Sonatin Icralarina Etki Durumu, *Turkiye Sosyal Arastirmalar Dergisi*, 2, 397.
- Ozen, M. (1998). *Gazi universitesi Gazi Egitim Fakultesi muzik egitimi bolumu son sinif ogrencilerinin piyanoyu muzik ogretmenliginin gerekleri dogrultusunda kullanabilme becerileri*. Yayimlanmamis Doktora Tezi. Gazi Universitesi Fen Bilimleri Enstitusu, Ankara, Turkey.
- Pajares, F. (1997). *Current directions in self-efficacy research*. In M. Maehr ve P.R. Pintrich (Eds.). *Advances in Motivation and Achievement*. Greenwich, CT: JAI Pres, pp. 1-49.
- Tural, Z. (2015). *Part B: "Evaluation of Problems for Students with Low-Motivation in Piano Training"*, pp.345-356. Art Studies, Hasan Arslan/Mehmet Ali Icbay/Christian Ruggiero (eds.), ISBN 978-3631-67501-4 Peter Lang Edition, Frankfurt 2015.
- Zimmerman, B. (2000). Self-efficacy: An essential motive to learn. *Contemporary Educational Psychology*. 25, 82-91.



# Assessment of Z-Book included in B2 Level of “Yedi İklim Türkçe Instruction Set” Used to Teach Turkish as a Foreign Language

Abdullah Sahin, Yuksel Girgin, Onur Gurbuz, Mesut Kalin Sali

## Introduction

Constructivist theory in the teaching and learning process is the act of organizing the preliminary knowledge by activating the upper cognitive skills and recreating the cognitive processes of the learners. In the process of reconstruction of mental and cognitive processes, textbooks have a significant contribution in foreign language teaching activities.

In addition to this, the introduction and application of new approaches and methods in a second language teaching process in the course of the process has provided different perspectives in terms of efficiency and educational activities. These studies on language teaching have become more prominent in the 20th century.

Every novelty that emerges in terms of language politics and ideologies within this century should be perceived as parallel to the developments in the field of education. In other words, educational sciences and language education act together in many ways. This contributes to infrastructure development of approaches and methods. In addition to a learning theory, the addition of a language theory to the components of the method accelerates studies on language learning teaching approaches and methods (Richards and Rodgers, 2014).

It is stated that the course materials developed in accordance with these, and especially textbooks, are based on the latest researches and findings in psychology, linguistics and pedagogy (Lightbown and Spada, 2006).

In this context, the Yedi İklim Turkish teaching set was prepared with the aim of teaching the Turkish language as a foreign language at the Yunus Emre Institute, Turkish Cultural Centres and many other Turcology departments. The Yunus Emre Institute Turkish Education Directorate, which continues to work in different geographical areas of the world, continues teaching Turkish as a foreign language in the Turkish Cultural Centres and various institutions.

Level B2 of teaching Turkish as a foreign language; students can participate in discussions held on their own expertise and understand and interpret the basic contents of complex texts for concrete and abstract issues in Turkish. Additionally, they can show the positive and negative aspects of various possibilities, they can speak fluently to people who speak Turkish and have a sufficient level of language competence to express their views on a comprehensive topic in a clear and detailed way (Gokmen, Ed. 2015).

## Sub-problems

1. What are the opinions of the students about the z-book used at level B2 of the Yedi İklim Turkish set?
2. Does the evaluation of the z-book differ according to the gender?

## Method

### Research Model

In this study, descriptive and correlational survey models are used as a quantitative research. Descriptive survey is a research model which aims to describe past or current situations (Karasar, 2006). On the other hand, the correlational survey model is used to reveal the relationship between two or more variables (Buyukozturk, et al., 2013).



### Sample Group

The implementation phase of the study was carried out with 18 students in Canakkale Onsekiz Mart University TOMER Program in the fall semester of 2017-2018 academic years. The target population of the study constitutes the students of Canakkale Onsekiz Mart University TOMER program in the fall semester of 2017-2018 academic years. 18 students in the TOMER program were included in the sample group. Students who volunteered to participate in the study formed the working group. 44,4% of the students (n = 8) were women and 55,6% (n = 10) were males.

### Data Collection Tool

As data collection tool, a 30-point likert type Learning Object Assessment Scale (LOAS) which is made reliability analysis and prepared by Guner and Yildirim (2014) was used.

### Data Analysis

The study data which was collected through data collection tool of this study were analysed with SPSS package program. According to the test results which is made in order to see whether the data have normal distribution, it has been inferred that the values of Skewness (0,70) and Kurtosis (-1,014) are in the range of -1,5 and +1,5 and with these values, data has normal distribution (Tabachnick and Fidell, 2013). The arithmetic mean was used to determine the participants' opinions about the z-book. The independent samples t-test was used to determine the gender-specific differentiation of the scores. These obtained data were interpreted and presented in tabular form.

### Findings & Discussion

#### What are the opinions of the students about the z-book used at level B2 of the Yedi Iklim Turkish set?

The "Learning Object Assessment Scale (LOAS)" was applied to the participant in order to get opinions of z-books users used at the B2 level of the Yedi Iklim Turkish set. Descriptive statistics for each scale item are given in Table 1.

Table 1

*Descriptive Statistics for Survey Material*

<b>Maddeler</b>	<b>n</b>	<b><math>\bar{X}</math></b>
1.Ogrenme nesnesi ile calismak konuyu ogrenmeme yardimci oldu.	1	3,0
	8	0
2.Ogrenme nesnesini kullanarak konuyu daha kolay ogrendim.	1	3,5
	8	0
3.Ogrenme nesnesindeki gorseller (grafik, animasyon, video vb.) konuyu ogrenmeme yardimci oldu.	1	3,2
	8	8
4.Bu ogrenme nesnesini kullanarak konu ile ilgili sorulari kolaylikla cevaplayabilirim.	1	3,4
	8	4
5.Ogrenme nesnesini kullanmak konu ile ilgili etkinlikleri daha cabuk yapmami sagladi.	1	3,4
	8	4
6.Bu ogrenme nesnesi sayesinde yeni bilgiler ogrendim.	1	3,5
	8	6
7.Ogrenme nesnesi yardimi ile bu konuyu ogrenme nesnesi kullanilmayan konulardan daha cabuk ogrendim.	1	3,3
	8	9
8.Ogrenme nesnesini kullanabilecek duzeyde bilgisayar becerisine sahibim.	1	3,3
	8	3
9.Ogrenme nesnesini kolayca kullanabildim.	1	3,4
	8	4

## Assessment of Z-Book included in B2 Level of “Yedi İklim Türkçe Instruction Set”

10.Ogrenme nesnesinin kullanimi basitti.	1	2,8
	8	9
11.Ogrenme nesnesi icindeki konular acik bir sekilde sunulmustu.	1	2,8
	8	9
12.Ogrenme nesnesinin kullanimini ogrenmek kolaydi.	1	2,8
	8	3
13.Gorsel acidan ogrenme nesnesini begendim.	1	3,0
	8	0
14.Ogrenme nesnesinin ekran tasarimi karmasikti.	1	3,1
	8	7
15.Ogrenme nesnesindeki konular mantikli bir siraya gore hazirlanmis.	1	3,1
	8	7
16.Ogrenme nesnesindeki butonlar (dugmeler) kolay anlasilabiliyordu.	1	3,5
	8	6
17.Ogrenme nesnesindeki gorsellerin (resim, grafik, video vb.) kalitesi cok dusuktu.	1	2,7
	8	2
18.Ogrenme nesnesindeki yazilar rahatlikla okunabiliyordu.	1	3,4
	8	4
19.Ogrenme nesnesindeki boluimler arasi gecis kolaydi.	1	3,3
	8	3
20.Genel olarak ogrenme nesnesinde anlatilan konuyu sevdim.	1	3,6
	8	7
21.Ogrenme nesnesini yeniden kullanmak isterim.	1	3,8
	8	3
22.Ogrenme nesnesi eglenceliydi.	1	3,5
	8	6
23.Ogrenme nesnesi dikkatimi konu uzerinde toplamami sagladi	1	3,6
	8	7
24.Ogrenme nesnesi konuya merakimi arttirdi.	1	3,6
	8	1
25.Ogrenme nesnesi konuyu ogrenme istegimi arttirdi.	1	3,5
	8	6
26.Dersteki etkinlikleri yapmak icin ogrenme nesnesini dikkatlice inceledim.	1	3,5
	8	6
27.Ogrenme nesnesi dersteki etkinliklerinin tamamini yapmama yardimci oldu.	1	3,4
	8	4
28.Ogrenme nesnesini kullanarak ders islemek eglenceliydi.	1	3,5
	8	6
29.Ogrenme nesnesi, dersteki etkiliklere ilgimi artirdi.	1	3,6
	8	1
30.Ogrenme nesnesi, anlatilan konu uzerinde derinlemesine dusunmemi sagladi.	1	3,6
	8	1
<b>Perceived Learning</b>	1	3,37
	8	
<b>Usability</b>	1	3,15
	8	
<b>Engagement</b>	1	3,58
	8	
<b>Total</b>	<b>1</b>	<b>3,37</b>
	<b>8</b>	

As shown in Table 1, the arithmetic mean of participants' response to scale items ranged from 2.72 to 3.67. The average score of z-book assessed by participants is 3,37. According to this, z-book seems to have a good effect on students' perceived learning (3,37) and participation (3,58). It can also be said that z-book availability (3.15) level is acceptable.

### Variation of LOAS scores according to gender

Independent samples were t-tested to determine whether the scores of the Learning Object Assessment Scale differ according to gender. The results obtained from this test are given in Table 2.

Table 2

*Variation of LOAS scores according to gender*

Grup	n	$\bar{X}$	SS	sd	t	p
Famale	8	3,97	0,83	16	2,41	0,28
Male	10	2,88	1,04			

As seen in Table 2, there is a significant difference ( $t(2,41) = 16, p >, 05$ ) between the scores of the LOAS of the female participants and the LOAS of the male participants. In addition, the average score of female participants' LOAS ( $\bar{X} = 3.97$ ) is higher than the average score of male participants. According to this, it can be said that female participants are more positive towards the learning object than men.

Developments that took place in the second half of the 20th century in the foreign language learning-teaching environments lead to a direction towards the conceptual-functional programs from the structural programs (Richards and Rodgers, 2014).

Turkish language textbooks as a foreign language have adopted direct contemporary programs because of the diversity of the communicative approach at a time when it is very common. In terms of findings, the important thing is that any book has not adopted only structural design as a traditional program (Akbulut and Yayli, 2015).

When it is looked at the studies related to the field which is about the content of Turkish textbooks as a foreign language, it is emphasized that textbooks included in the program generally have adopt functional method based on teaching of concepts. In addition, traditional and structuralist teaching methods seem to be used as well.

Skill-based language teaching activities not included in Nunan's (1993) classification were proposed by Mohseni-Far (2008). In this study, this kind of program was found in two separate books. Textbooks that help teaching Turkish as a foreign language have not been evaluated in terms of program. Therefore, it is impossible to compare the findings of this study with others. However, from now on, similar studies to be applied can examine different book sets, new presses of existing sets and other course materials (Akbulut and Yayli, 2015).

Activities related with teaching Turkish as a foreign language and the application of methods-strategies can be regarded as new. Much as all these studies on the field will form teachers' and researchers' language teaching awareness, they provide them to be self-consistent in the use of educational materials and benefit surveillance.

### Conclusion

In this study, it is made the evaluation of the z-book used at B2 level of the "Yedi İklim Turkish" set which is one of the Turkish teaching sets as a foreign language. The results obtained are presented below.

The results of the students' opinions on the z-book used at B2 level of the "Yedi İklim Turkce" set is shown that with LOAS scores of participants, their opinions about z-book is at acceptable level. According to these findings, it is inferred that the z-book is suitable for using it.

When it is examined findings in relation that whether z-book assessment differs according to gender, significant ( $t(2, 41) = 16, p >, 05$ ) findings are obtained. In addition, it is found that female participants' LOAS mean score of evaluation item scale (= 3.97) is higher than LOAS average scores of

male participants, which is a significant difference in favour of female participants. Therefore, it is concluded that the LOAS scores are related to gender.

### References

- Akbulut, S. & Yayli, D. (2015). Yabancı dil olarak Türkçe öğretimi A1-A2 düzeyi ders kitapları üzerine bir izlenim çalışması. *Erzincan Üniversitesi Sosyal Bilimler Enstitüsü Dergisi*, 35-46.
- Buyukozturk, S., Kilic Cakmak, E., Akgun, O. E., Karadeniz, S. & Demirel, F. (2013). *Bilimsel araştırma yöntemleri* (15. baskı). Ankara: Pegem Yayıncılık.
- Gokmen, M. E. (Ed.) (2015). *Yabancı dil olarak Türkçe öğretim programı*. Ankara: Ankara Üniversitesi Basımevi.
- Gurer, M. D. & Yildirim, Z. (2014). Öğrenme nesnesi değerlendirme ölçeği'nin (ONDO) geliştirilmesi, geçerlik ve güvenilirlik çalışması. *Eğitim ve Bilim*, 39(176). ISO 690
- Karasar, N.(2006). *Bilimsel araştırma yöntemi*. Ankara: Nobel Yayın Dağıtım.
- Richards, J. C., & Rodgers, T. S. (2014). *Approaches and methods in language teaching*. New York: CUP.
- Tabachnick, B. G. & Fidell, L. S. (2013). *Using multivariate statistics* (sixth ed.). Boston: Pearson.
- Yayli, D. (2010). Yöntem sonrası dönem ve yabancı dil olarak Türkçe, yabancı dil olarak Türkçe öğretiminde yeni çalışmalar. 8. *Dünyada Türkçe Öğretimi Sempozyumu Bildirileri* (219-223). Ankara: Ankara Üniversitesi Basımevi.
- Yayli, D. & Yayli, D. (2011). Yabancı dil öğretimi yaklaşımları ve yöntemleri. D. Yayli ve Y. Bayyurt, (Ed.), *Yabancılara Türkçe öğretimi: politika, yöntem ve beceriler* (7-28) içinde. Ankara: Ani Yayıncılık.



# Examination of 12th Grade Students' Cognitive Structures about Electrochemical Concepts through Word Association Test

Canan Nakiboglu, Nuri Nakiboglu

## 1. Introduction

While concepts are taught both in textbooks and by teachers, generally the concept is tried to teach by introducing its definition at the beginning of the course. It is not considered that whether the learner can relate the concept taught to the concepts of the previous subject. At the end of the course, the students' understanding of the topic is also measured by mathematical questions in general. It is not interested in how the students establish the relationship between the concepts of the topic. On the other hand, one of the most important points in concept teaching is to provide the students to construct the relationship between concepts in their mind. When the student cannot establish appropriate relationships among the concepts in the mind, the students do not learn the topics meaningfully. Besides, one of the reasons for the misconceptions that are often encountered in teaching is that the concepts are not learned by the students in a meaningful way. For this reason, researchers have been interested in how students think about the concepts of chemistry and how they organize knowledge in their minds.

The structure that shows the relation between the concepts related to a subject in the minds of the student is known as cognitive structure. The cognitive structure is also accepted as an essential issue both in remembering the learned material and in learning new material (Gordetsky & Hoz, 1985). For that reason, uncovering the students' cognitive structure is significant for assessing what a student knows about the subject knowledge and whether the students have the misconceptions about the topic. To acquire the students' prior knowledge can guide teachers to design suitable teaching approaches in their classless.

The cognitive structures of learners can be explored as individual or group cognitive structures. There are several ways to learn about the students' cognitive structures. The concept map and flow diagram from these ways provide a way for students to identify their individual cognitive structures. Word association tests (WATs) are often used to obtain group cognitive structures of students (Nakiboglu, 2008) and the knowledge space theory (KST) can be applied for studying the cognitive organization of knowledge characteristic of a group of students (Tóth, 2007).

WAT is one of the methods used to determine the cognitive structure of a learner and the linkages between concepts in this structure and whether the relationships between concepts in the long-term memory (Nakiboglu, 2008). In this method, the student is asked to write the words he/she brings to the mind of a stimulus concept given in relation to any subject within a certain period. It is assumed that the sequential answer given to any stimulus concept by the learner in his long-term memory shows the semantic proximity which is revealed by the connections between concepts in the cognitive structure. Shavelson (1972) cited that the assumption about WAT is that the order of responses reflects at least a significant part of the structure within the semantic memory, and between concepts.

### 1.1 The rationale of the study

Electrochemistry is one of the topics in secondary school chemistry curricula. This topic also plays an important role in everyday life. Yang, Greenbowe and Andre (2004) indicated that one of the purposes of teaching electrochemistry is to have students apply electrochemistry concepts and principles to real-world applications. On the other hand, the studies have shown that electrochemical concepts have been perceived as difficult by both students in secondary chemistry and university general chemistry courses (Allsop & George, 1982; Brandriet & Bretz, 2014; Garnet & Treagust, 1992a and 1992b; Serger & Greenbowe, 1997a and 1997b; Schmidt, Marohn & Harrison, 2007; Yang et al., 2004).

In the literature, it has been seen that the students' difficulties of some electrochemistry topics have been studied. Most of them are concerning electric circuits, salt bridge, reduction-oxidation reactions, electrochemical cells, and electrolytic cells. While Allsop and George (1982) reported that students had difficulty using standard reduction potentials to predict the direction of chemical reactions, Garnett and Treagust (1992a, 1992b) searched Australian high-school students' misconceptions about the flow of current in electrolyte solutions and the salt bridge. Garnett and Treagust (1992a, 1992b) found that students thought that "electrons move through solution by being attracted from one ion to the other" and "electrons enter the solution from the cathode, travel through the solutions and the salt bridge, and emerge at the anode to complete the circuit", and "the anode is positively charged because it has lost electrons; the cathode is negatively charged because it has gained electrons". Sanger and Greenbowe (1997a) also replicated, with additions, Garnett and Treagust's interview study (1992a) to explore American university students' misconceptions about galvanic (electrochemical), electrolytic, and concentration (Nernst) cells. They reached the misconceptions which previously reported in Garnett and Treagust's study and also not reported ones. They found originally that "electrons can flow through aqueous solutions without assistance from the ions" and "only negatively charged ions constitute a flow of current in the electrolyte and the salt bridge".

Yang et al., (2004) conducted a study to investigate the misconceptions held by college freshman chemistry students about batteries and flashlights prior to studying electrochemistry. They found that students had eight misconceptions that four were relate to batteries and four were relate to electric circuits. Two examples of misconception about batteries were that "Batteries are dead when all the electrons inside a battery are used up." and "The "+" and the "-" ends of the batteries are charged, so the "+" end of a battery attracts electrons". One example misconception about electric circuits were that "The electrons come out of the cathode, go through the bulb, flow through a wire outside batteries, come back to the anode, and pass through the paste".

Schmidt et al. (2007) investigated secondary-school students' problems in learning electrochemistry. Their investigation covered four areas: (1) electrolytes, (2) transport of electric charges in electrolyte solutions, (3) the anode and the cathode, and (4) the minus and plus poles. They reached that students had four alternative concepts which were "during electrolysis, the electric current produces ions; electrons migrate through the solution from one electrode to the other; the cathode is always the minus pole, the anode the plus pole; and the plus and minus poles carry charges.

When the studies about electrochemistry are examined, it is shown that most of the question contain complex algorithmic problems or several dual concepts such as anode-cathode, reductant-oxidant, and reduction-oxidation are asked together. In addition, the instruments used consist of mostly multiple choice questions. Nevertheless, it is not encountered the study showing how the relationships between the concepts of electrochemistry in the students' mind. From this point on in this study, it is aimed to investigate through a word association test how secondary students' cognitive structure (CS) about the basic concepts of electrochemistry. Depending on this purpose, the study is structured according to the following two research problems.

1. What is the relationship between the basic concepts of electrochemistry in the 12th-grade students' CS after "Chemistry and Electricity" unit teaching?
2. How well are these relationships established in the students' CS?

## 2. Method

### Participants

The data gathered from the 55 12<sup>th</sup> grade students attending in a high secondary school with academic success. The reason for choosing a high school with academic success is that the topic of electrochemistry is a very difficult for the students to understand as mentioned in many studies.

### Data Collection Tool and Administration

To develop the WAT, ten key concepts acting as stimulus were chosen in this study by the authors firstly. These concepts were *electrolyte*, *anode*, *cathode*, *electrode*, *reduction*, *oxidation*, *salt bridge*, *electrolysis*, *conductivity*, and *electrochemical cell*. To provide the content validity of the WAT, "Chemistry and Electricity" unit of the secondary school chemistry curriculum was examined by authors who of one are the expert of electrochemistry. The expert judgment was also provided by an experienced high school chemistry teacher (Gay & Airasion, 2000, p. 163). The students were provided with a booklet, each page of which contained one of the ten stimulus concepts. They were asked to write down within 30 seconds as many response words as they could think of in association with each stimulus concepts placed in the WAT. The teacher of the class administered WATs and controlled the time.

### Data Analysis

There are several methods of analyzing the data obtained by a WAT. One of them is the relatedness coefficient method suggested by Garskof and Houston (Stewart, 1979, p. 386). This method is based on the degree of overlap between two response lists to a certain pair of stimulus words (Johnstone & Moynihan, 1985; Gussarsky & Gorodetsky, 1988). Another method of representing CS is by drawing a map. Wearn (1972, cited in Preece, 1976, p. 4) has suggested that graphic representations of the cognitive structure are obtained from the relatedness coefficient (RC) values for stimuli concepts. Other researchers draw a map using response frequencies instead of RC values for looking for relations used by Bahar, Johnstone & Sutcliffe (1999). In this method, from all the students' responses to every stimulus word, a frequency table is obtained. Nakiboglu (2008) also suggested a method which contains an integration of first and second methods. In this method, to obtain the CS from WAT analysis is drawn a map by using frequencies. On the map, the direction of the arrows and strength of associations are established by using the frequency tables. In this study, Nakiboglu's method was used for the data analysis.

### 3. Findings

The response concepts to each stimulus concept were counted from all the students' responses in the WAT. Firstly, how many meaningful response concepts are derived for all stimulus concepts are presented in Figure 1. From Figure 1, it can be said that total response concept numbers for all stimulus concepts range from 20 to 34. While the maximum number is 34 written for the concept of "cathode", the least number is 20 written for the concept of "conductivity". To map the student's cognitive structure, it is need to tabulate the frequencies of each response concepts against stimulus concepts firstly. Since the frequency table obtained in this study contain a huge amount of material, they are not given all response concepts there. However, to interpret accurately how the Figure 2-5 were drawn, a sample pattern of the frequency table is given in Table 1. The maps of students' CS were drawn from the frequency tables and are presented in Figures 2-5 for each frequencies' range. These maps make it possible to determine both the power and the direction of associations between both stimulus and stimulus and response, and also to interpret the relationships between concepts of electrochemistry in the students' minds better.

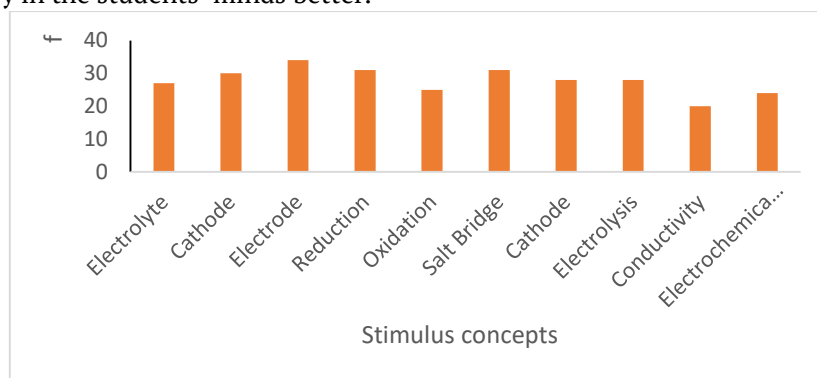


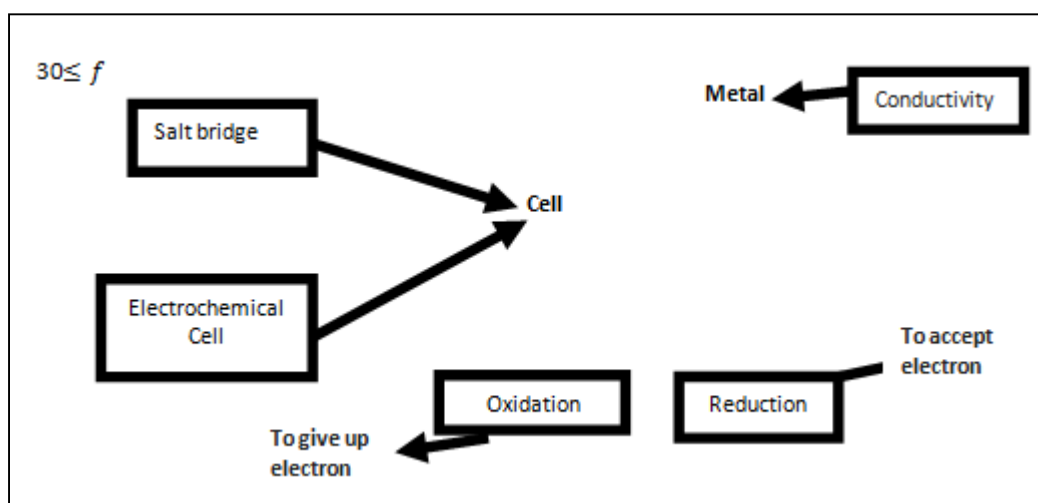
Figure 1. The number of response concepts to each stimulus concept.



**Table 1.** A part of the sample pattern of the frequency table

RESPONSE CONCEPTS	STIMULUS CONCEPTS									
	Electrolyte	Anode	Cathode	Electrode	Reduction	Oxidation	Salt Bridge	Electrolysis	Conductivity	Electrochemical Cell
Anode	14	1	11	4	3	8	17	12	-	16
Cathode	14	12	4	6	10	3	17	11	-	16
Electrode	1	3	2	-	-	1	2	1	-	4
Reduction	4	4	14	4	-	10	2	3	1	7
Oxidation	3	14	1	4	5	5	2	3	1	8
Salt Bridge	2	5	5	6	-	3	-	3	-	12
Conductivity	3	2	1	2	-	-	1	1	-	-
Positive charge	16	22	18	4	6	7	5	5	1	-
Solution	26	11	6	12	3	2	8	8	5	7
Bar	11	6	5	17	-	1	2	-	3	-
Negative charge	8	26	23	5	8	1	4	7	-	-
Electricity	16	4	5	9	2	2	2	18	24	8
Electron	8	15	13	12	16	14	6	12	10	11
To accept electron	-	3	3	1	36	2	-	1	-	-
To give up electron	-	2	3	1	3	37	-	2	-	-
Galvanic	2	-	-	1	1	-	2	-	1	16
Ion	10	7	3	3	6	7	18	13	15	1
Metal	6	4	7	9	3	7	2	2	38	-
Cell	20	21	23	19	8	9	32	13	7	33
Redox	-	-	3	-	21	19	-	2	-	2
Water	8	-	-	-	-	-	-	12	-	-
Reaction	-	2	1	-	14	11	3	5	-	2

As seen from Table 1, because the highest frequency was  $30 \leq f$ , this value was selected as the beginning frequency range for mapping (Figure 2).

**Figure 2.** The students' cognitive structures for  $30 \leq f$

## Examination of 12th Grade Students' Cognitive Structures

When Figure 2 is examined we can see that although five stimulus concepts appeared at the highest frequencies, there is no direct association between two stimulus concepts. There four separate islands and the two stimuli (salt bridge and electrochemical cell) are related to the response concept, cell, in one of the islands.

When the frequency range was lowered to  $25 \leq f \leq 29$ , two more separate islands appeared at this frequency. So, six separate islands and seven stimuli words occur in Figure 3. There is still no associations between any stimuli.

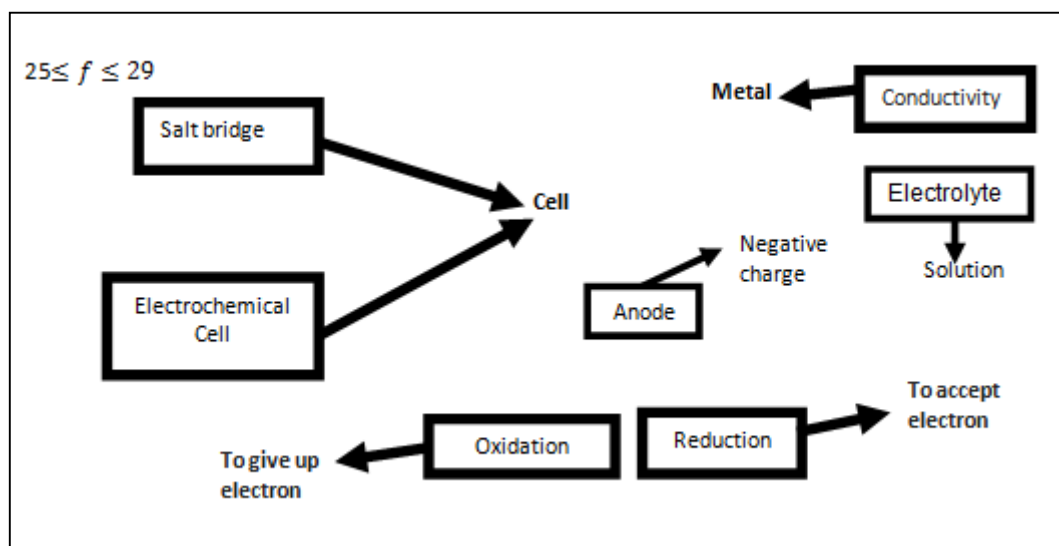


Figure 3. The students' cognitive structures for  $25 \leq f \leq 29$

Until the frequency range was lowered to  $20 \leq f \leq 24$ , it seems that there is disconnected ideas in the students' minds and some islands began to come together related to a response concept, *cell*. There is still three separate island on the map.

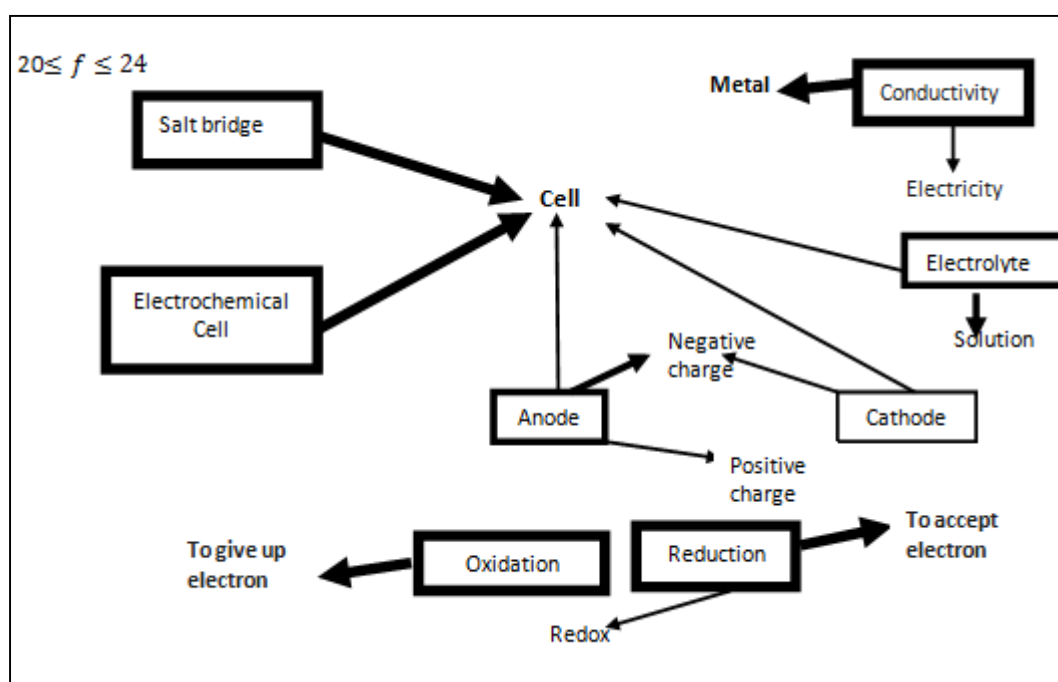


Figure 4. The students' cognitive structures for  $20 \leq f \leq 24$

In Figure 5, the frequency range  $15 \leq f \leq 19$ , all stimulus concepts appear on the map and while the two separate islands are connected to each other via the response word *electron*, two other separate islands are connected to each other via the response concepts *electricity* and *ion*.

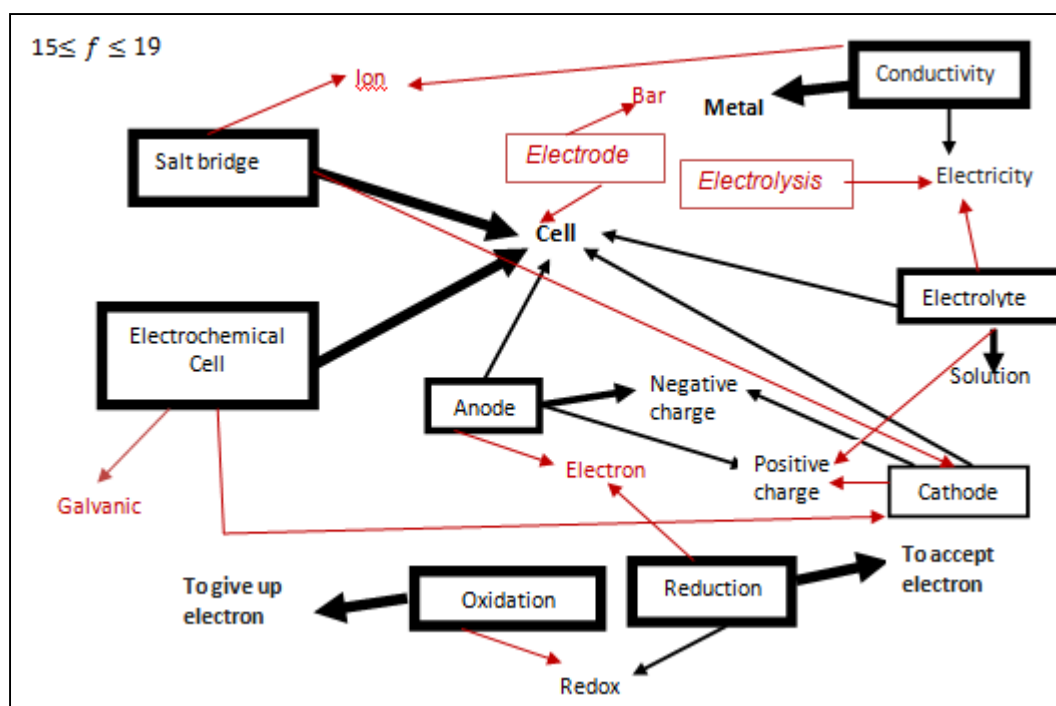


Figure 5. The students' cognitive structures for  $15 \leq f \leq 19$

#### 4. Discussion

At the end of the study, it was determined that most of the electrochemical concepts in the WAT were related to the cognitive structures of the students. On the other hand, although it has been concluded that relationship between some of the concepts of electrochemistry are established, some relationship between them is not established or very weak. It has been also determined that the electrolysis was not to be connected to the students' cognitive structure via anode and cathode, but the conductivity and electrolyte are weakly connected each other over the concept of electricity. It can be said that students could not establish a relationship between electrolysis and electrochemical cells and parts. In their study, Nakiboglu & Nakiboglu (2017) determined that students were not very successful in the test in which multiple-choice questions including the components and basic concepts of electrochemical cells take place.

Another consequence of the study is that the relationship between the stimuli concepts *oxidation* and *reduction*, and the response concepts *giving up* and *acceptance electron* is established correctly. Moreover, the high frequency of this relationship can indicate that the relationship is strong. This result shows that students can only establish better relationships in the basic situation. The other correct relationship that appears at high frequency is the relationship between the stimulus concept, *electrolyte*, and the response concept, *solution*. Students have correctly correlated the parts of the electrochemical cell with each other, but only with a weak relationship. It was also determined that 6 of the given key concepts were linked to each other via the concept of "cell", which is the response concept.

The concept of conductivity, the stimulus concept, appears at the highest frequency ( $30 \leq f$ ) on the map. However, it is seen that the conductivity is not related to other electrochemical concepts until the lowest frequency. Furthermore, the first response concept to the concept of conductivity is the metal. This suggests that students perceive conductivity as metallic conductivity. This supports the conclusions about conductivity in studies on electrochemistry. Garnett and Treagust (1992a) suggested

that the misconceptions about the conductivity of electrolytes can be related to prior learning concerning the concept of electrical conductivity of metals. Since the concept of conductivity in metals is introduced to the students earlier, this can be usually over-generalized by students. At the same time, this situation is linked to that some concepts such as conductivity have been introduced to the same group of students in both physics and chemistry class by using the different style. Relating this situation, Yang et al., (2004) said that the chemistry instructors focus their lessons on what is happening inside of electrochemical cells, while physics instructors focus their lesson on how current flows in a circuit. Even though those two concepts are closely related, without instructors' deliberate efforts, it is not easy for students to make connections between the two concepts. For this reason they have recommended that an instructional package is needed to put some of the concepts of physics and chemistry together so students can develop a better conceptual understanding of how commercial batteries operate in a circuit to do useful work.

As it is seen in the present study, it is understood that some of the relations between the basic electrochemistry concepts are either not established or very weakly established in the cognitive structures of the students after teaching. It can be said that this is mostly related to teaching the subject. In this case, different teaching methods can be suggested in teaching electrochemistry. Some of the researchers examined this situation. For example, Yang et al., (2004) investigated whether using an Interactive Software Program (ISP) would reduce students' misconceptions about batteries. They used instruction that started with something familiar to help students link a real-world context to concepts and principles in chemistry and physics. They found that the percentage of the students who expressed misconceptions was reduced on the post-test for the most of the categories as a result of the ISP instruction. For this reason, we can recommend that this type software programs should use to teach electrochemistry concepts firstly. Besides, to link between everyday life and abstract concepts during instruction can be helped the students understand the abstract concepts of electrochemistry.

## 5. References

- Allsop, R. T., & George, N. H. (1982). Redox in Nuffield advanced chemistry. *Education in Chemistry*, 19, 57-59.
- Bahar M., Johnstone A. H., & Sutcliffe R. G. (1999). Investigation of students' cognitive structure in elementary genetics through word association tests, *Journal of Biology Education*, 33, 134-141.
- Brandriet, A. R., & Bretz, S.L. (2014). Measuring meta-ignorance through the lens of confidence: examining students' redox misconceptions about oxidation numbers, charge, and electron transfer. *Chemistry Education Research and Practice*, 15, 729-746.
- Garnet, P. J., & Treagust, D. F. (1992a). Conceptual difficulties experienced by senior high school students of electrochemistry: Electrochemical (Galvanic) and electrolytic cells. *Journal of Research in Science Teaching*, 29(10), 1079-1099.
- Garnet, P. J., & Treagust, D. F. (1992b). Conceptual difficulties experienced by senior high school students of electrochemistry: Electric circuits and oxidation-reduction equations. *Journal of Research in Science Teaching*, 29(2), 121-142.
- Gay, L. R., & Airasion, P. (2000). *Educational research: competencies for analysis and application.*, New Jersey: Prentice-Hall.
- Gordetsky, M., & Hoz, R. (1985). Changes in the group cognitive structure of some chemical equilibrium concept following a university course in general chemistry. *Science Education*, 69(2), 185-199.
- Gussarsky, E., & Gorodetsky, M. (1988). On the chemical equilibrium concept: constrained word associations and conception. *Journal of Research in Science Teaching*, 25(5), 319-333.
- Johnstone A. H., & Moynihan T. F. (1985). The relationship between performances in word association tests and achievement in chemistry. *European Journal of Science Education*, 7, 57-66.
- Nakiboglu, C. (2008). Using word associations for assessing non major science students' knowledge structure before and after general chemistry instruction: the case of atomic structure. *Chemistry Education Research and Practice*, 9, 309-322.

- Ogude, A.N., & Bradley, J. D. (1994). Ionic conduction and electrical neutrality in operating electrochemical cells: pre-college and college student interpretations, *Journal of Chemical Education*, 71(1), 29-34.
- Ogude, A.N., & Bradley, J. D. (1996). Electrode processes and aspects relating to cell emf, current, and cell components in operating electrochemical cells: Precollege and college student interpretation. *Journal of Chemical Education*, 73(12), 1145-49.
- Preece, (1976). Preece P. F. W., (1976), Mapping cognitive structure. *Journal of Educational Psychology*, 68(1), 1-8.
- Sanger, M. J., Greenbowe, T. J. (1997a). Students' misconceptions in electrochemistry: Current flow in electrolyte solutions and the salt bridge. *Journal of Chemical Education*, 74(7), 819-823.
- Sanger, M. J., & Greenbowe, I. J. (1997b). Common students' misconceptions in electrochemistry: Galvanic, electrolytic and concentration cells. *Journal of Research in Science Teaching*, 34(4), 377-398.
- Schmidt, H-J., Marohn, A., & Harrison, A. G. (2007). Factors that prevent learning in electrochemistry. *Journal of Research in Science Teaching*, 44(2), 258-283.
- Shavelson, R. J. (1972). Some aspects of the correspondence between content structure and cognitive structure in physics instruction. *Journal of Educational Psychology*, 63(3), 225-234.
- Stewart, J. (1979), Content and cognitive structure: Critique of assessment and representation techniques used by science education researchers. *Science Education*, 63(3), 395-405.
- Tóth, Z. (2007). Mapping students' knowledge structure in understanding density, mass percent, molar mass, molar volume and their application in calculations by the use of the knowledge space theory. *Chemistry Education Research and Practice*, 8, 376-389.
- Yang, E. M., Greenbowe, T. J., & Andre, T. (2004). The effective use of an interactive software program to reduce students' misconceptions about batteries. *Journal of Chemical Education*, 81(4), 587-595.

# Evaluation of "Chemistry and Electricity" Unit of 12th Grade Chemistry Textbook in terms of the Chemistry Triplet

Canan Nakiboglu, Nuri Nakiboglu

## 1. Introduction

Chemical knowledge is expressed at three different levels called the macroscopic, the sub-microscopic, and the symbolic levels. The macroscopic level contains the actual phenomena that it is experienced in the daily lives or in the laboratory. This is the level of the observable and tangible (Gabel, 1999). The sub-micro level includes atoms, molecules, ions, and structures. The representational level is concerning symbols, formulae, equations, molarity, and mathematical manipulation and graphs (Johnstone, 2000). It can be said that the teaching and learning of chemistry require multiple thoughts.

This triplet relationship is often represented graphically in terms of a triangle and this model, "the chemistry triplet" was highlighted by Johnstone in 1983 (Johnstone, 1993; Johnstone, 2000). Taber (2013) cited that "Johnstone's triangle has in effect become a 'taken-for-granted' commitment (or assumption) for those working in the field of chemistry education (p.156)".

The idea of explaining, examining, or teaching the three levels of chemistry, a crucial view in the understanding of chemistry knowledge, has been one of the most powerful and productive ideas in chemistry education for the last thirty years. The chemistry triplet has been adopted by many chemistry educators and has maintained its basic philosophy even though it is interpreted differently by some. Talanquer (2011) has pointed out that most chemistry teaching is focused on the sub-micro-symbolic relationship and seldom helps students to build relations between the three levels. He has also cited that this kind of teaching duration could result in confusion and some problems could be seen as students' achievement in the chemistry classroom. In addition to this, he was concerned about although the chemistry triplet was very useful in highlighting core components of the chemical knowledge, it was careful in its application and interpretation.

### 1.1 The rationale of the study

"Chemistry and Electricity" is one of the units in 12th-grade chemistry curricula which is related to electrochemistry. This topic has considerable importance in much application such as batteries, corrosion, and electrolysis in daily life. Yang, Greenbowe, and Andre (2004) have also indicated that one of the purposes of teaching electrochemistry is to have students apply electrochemistry concepts and principles to real-world applications. However the studies have shown that electrochemical concepts are mostly perceived as difficult by students (Allsop & George, 1982; Brandriet & Bretz, 2014; Garnet & Treagust, 1992a and 1992b; Nakiboglu & Nakiboglu, 2017a and 2017b; Ogude, & Bradley, 1994; Ogude, & Bradley, 1996; Ozkaya, 2002; Rahayu, Treagust, Chandrasegaran, Kita, & Ibnu, 2011; Senger & Greenbowe, 1997a and 1997b; Schmidt, Marohn & Harrison, 2007; Yang et al., 2004). While the teaching of the concepts of electrochemistry, the students were presented with and asked to make sense of teaching about the macro (cell, an anode, cathode, and salt bridge), the sub-micro (ions and electrons) and the symbolic (redox equation).

Textbooks prepared in the direction of curricula are guided in many subjects such as teaching at the same time and carrying out class activities in case of planning the course. Research has indicated that textbooks are used as the most basic resources outside the classroom and in the classroom for the teaching of science subjects, and for this reason, they still have a very big importance for students (Nakiboglu, 2009).

Since the textbooks are an important teaching tool, they can facilitate students' conceptual understanding of the topics taught. While presenting electrochemistry concepts in the textbooks, it is important to know to what extent the chemistry triplet is used correctly and the relations between the

three levels are established acceptably. The purpose of this study is to determine the correct use of the triple representation of the chemist in the "Chemistry and Electricity" unit of the 12th-grade chemistry textbook.

## 2. Method

The study is a *qualitative research*, and *descriptive research method* is used. The descriptive method describes existing conditions (Buyukozturk, Kilic Cakmak, Akgun, Karadeniz & Demirel, 2009).

### 2.1. Sampling

The sample of the study was selected by using *purposive sampling technique*. Purposive sampling allows for the selection and in-depth study of wealthy situations depending on the purpose of the work being undertaken (Buyukozturk, Cakmak, Akgun, Karadeniz, Demirel, 2009). Two 12-th grade textbooks written according to the year 2013 program were selected for the study. While textbook #1 is the book that is suitable for use in the 2016-2017 academic year, textbook # 2 is the book that is suitable for use in the 2017-2018 academic year. 12-th grade textbook consist of four units and "Chemistry and Electricity" unit is the first unit. This unit contains five section and these are: oxidation-reduction reaction, electrochemical cells, standard electrode potential, electrochemical cells, and electrolysis. Due to the right of publication, figures and photographs of the textbooks were not used on the text.

### 2.2. Data Collection and Data Analysis

As a data collection method in the study, *documentary analysis method* was used (Karasar, 2005). In this method, which is also referred to as *the method of document review*, analysis of written materials containing information about the cases or phenomena targeted for investigation is performed (Yildirim & Simsek, 2011).

Data Analysis was performed by the content analysis method. Firstly, the studies on the triple representation of the chemistry in the literature were examined. Then all the books were analysed in general to create a rubric. After this first analysis, a rubric was developed and it was decided that the representations should be separated as figure and photograph. All figures and photographs placed in textbooks analysed separately by using the rubric developed. Finally, all statements on the text were analysed by using rubric.

## 3. Findings

While the data concerning representations were presented separately for each book, data about text analysis were given for two textbooks together. The data analysis presentation was explained below. Firstly, the numerical data obtained according to the macro, sub-micro, and symbolic levels concerning representations were given in the table. Tables included both numbers of representation and the representations which contain problems according to chemistry triplet usage. Then the findings of each level group were explained through examples. Finally, text analysis were presented.

### 3.1. Findings concerning textbook 1

The data concerning representations obtained according to the macro, sub-micro and symbolic levels usage are given in Table 1.

**Table 1.** Distribution of figures and photographs in textbook 1 according to chemistry triplet usage

TYPE OF REPRESENTATION	Chemistry Triplet	Number of Representation	Number of Problematic Representation
<b>Figure</b>	Macro/Symbolic/Sub-Micro	7	3
	Macro/Symbolic	12	6
	Macro/Sub-Micro	3	-
	Macro	2	-
<b>Sum of figure</b>		24	9
<b>Photograph</b>	Macro/Symbolic/Sub-Micro	-	-
	Macro/Symbolic	1	1
	Macro	22	1
<b>Sum of Photograph</b>		23	2

When Table 1 is examined, it is seen that there are 34 of figures and 23 of photographs in the "Chemistry and Electricity" unit. There are 7 of figures in Macro/Symbolic/Sub-Micro category, 12 of figures in Macro/Symbolic category, 3 of figures in Macro/Sub-Micro category and 2 of figures in Macro category. 3 of figures about Macro/Symbolic/Sub-Micro category were found to be problematic and 6 of figures of Macro/Symbolic category were problematic.

One of the figures of Textbook 1 shows an example figure which contains *Macro/Symbolic/Sub-Micro* representation used together in a figure and this figure also represent problematic usage of the chemistry triplet levels. Title of Figure 1 in the textbook is "ions moving from Zn electrode to solution". In this figure, while Zn electrode, salt bridge and solution is related to macro level, representations such as  $Zn^{2+}$ ,  $NO_3^-$  and  $Zn(NO_3)_2$  are concerning to symbolic level. There is a fragment taken from the electrode shows the particular structure of the matter and this part of the figure is concerning sub-macroscopic level. In this figure, although the physical state of  $Zn(NO_3)_2$  is correctly shown in parentheses, that is (aq), the physical state of Zn is not shown as Zn (s). ("s" represent "solid" and "aq" represents "aqueous")

Regarding to photographs, there is not any photograph in *Macro/Symbolic/Sub-Micro* category, there is only 1 of figure in *Macro/Symbolic* category, and there are 22 of photographs in *Macro* category. Figure shows an example photograph which contains *Macro/Symbolic* representation used together in a photograph and this photograph also represents problematic usage of the chemistry triplet levels. In this photograph, solutions placed in beakers are related to macro level and the reaction equation is concerning symbolic level. The physical states of reactants and products of reactions such as solid, liquid, gas and aqueous are not shown on the equation.

### 3.2. Findings concerning textbook 2

The data concerning representations obtained according to the macro, sub-micro and symbolic levels usage for textbook 2 are given in Table 2.



**Table 2.** Distribution of figures and photographs in textbook 2 according to chemistry triplet usage

TYPE OF REPRESENTATION	Chemistry Triplet	Number of Representation	Number of Problematic Representation
Figure	Macro/Symbolic/Sub-Micro	-	-
	Macro/Symbolic	16	10
	Macro/Sub-Micro	-	-
Sum of figure	Macro	1	-
		17	10
Photograph	Macro/Symbolic/Sub-Micro	-	-
	Macro/Symbolic	-	-
	Macro	18	-
Sum of Photograph		18	-

When Table 2 is examined, it is seen that there are 17 of figures and 18 of photographs in the “Chemistry and Electricity” unit of textbook 2. There are 16 of figures in *Macro/Symbolic* category and 1 of figure in *Macro* category. 10 of figures of *Macro/Symbolic* category were found to be problematic. Two Figures of Textbook 2 show two example figures which contain *Macro/Symbolic* representation used together in a figure and two of them concerning galvanic cell. Although the first figure represents problematic usage of the chemistry triplet levels, there is not similar problem in the another figure. In both of them, while electrodes, salt bridges, copper wires and solutions are related to macro level, representations such as  $Zn^{2+}$ ,  $Cu^{2+}$ ,  $SO_4^{2-}$ ,  $CuSO_4$  and  $ZnSO_4$  are concerning to symbolic level.

In the first figure, although the physical states of  $ZnSO_4$ ,  $CuSO_4$ , that is (aq), are correctly shown in the parentheses, the physical states of Zn and Cu electrodes are not shown as Zn(s) and Cu(s) in the parentheses. On the other hand, in the second figure, all physical states were shown correctly.

### 3.3. Findings about misuse of chemistry triplet on the text

Problems with *Macro/Sub-Micro* representations

1. The thinking is that a matter and its constituent unit were considered as the same. An example statement placed in the Textbook #1 is shown below.  
“In the spontaneously reaction of sodium metal with hydrochloric acid, sodium metal reacts by giving an electron. Hydrogen takes an electron and turns into hydrogen gas.”

In this statement, it was considered that metals give electron. On the other hand, a metal atom gives electron. Similarly, hydrogen atom takes electron.

2. The subscripts that indicate the physical properties of the compounds were not written on their side. This causes the matter in the macroscopic level to mix with the particles in the sub-microscopic level. An example statement taken from textbook 1 is shown below.

“In a compound, the sum of the oxidation steps of the atoms is zero. For example, the sum of the oxidation step of atoms in the compounds  $CO_2$ ,  $NH_3$ ,  $CaBr_2$  is zero”

## 4. Discussion

At the end of the study, it was shown that the "Chemistry and Electricity" unit required multiple thoughts based on the chemistry triplet during teaching. However, it has been concluded that in many equations macro-sub micro relations is not been taken much attention. The subscripts that indicate the physical properties of the compounds were not written on their side both in the presentations and on the text. This is an indication why students have problems about "chemistry and electricity" unit.

### Acknowledgments

Research reported in this publication was supported by Balikesir University BAP with the project number 2017/165.

### 5. References

- Allsop, R. T., & George, N. H. (1982). Redox in Nuffield advanced chemistry. *Education in Chemistry*, 19, 57-59.
- Brandriet, A. R., & Bretz, S.L. (2014). Measuring meta-ignorance through the lens of confidence: examining students' redox misconceptions about oxidation numbers, charge, and electron transfer. *Chemistry Education Research and Practice*, 15, 729-746.
- Buyukozturk, S., Kilic Cakmak, E., Akgun, O. E., Karadeniz, S., & Demirel, F. (2009). *Bilimsel arastirma yontemleri* (3. Baski). Ankara: Pegem A Akademi.
- Garnet, P. J., & Treagust, D. F. (1992a). Conceptual difficulties experienced by senior high school students of electrochemistry: Electrochemical (Galvanic) and electrolytic cells. *Journal of Research in Science Teaching*, 29(10), 1079-1099.
- Garnet, P. J., & Treagust, D. F. (1992b). Conceptual difficulties experienced by senior high school students of electrochemistry: Electric circuits and oxidation-reduction equations. *Journal of Research in Science Teaching*, 29(2), 121-142.
- Gabel, D. L. (1993). Use of the particle nature of matter in developing conceptual understanding. *Journal of Chemical Education*, 70(3), 193-194.
- Johnstone, A. H. (1993). The development of chemistry teaching: A changing response to changing demand. *Journal of Chemical Education*, 70(9), 701-705.
- Johnstone A. H., (2000), Teaching of chemistry – logical or psychological? *Chemistry Education: Research and Practice in Europe*, 1(1), 9-15.
- Karasar, N. (2005). *Bilimsel Arastirma Yontemi* (8. Baski). Ankara: Nobel Yayin Dagilim.
- Nakiboglu, C. (2009). Deneyimli Kimya Ogretmenlerinin Ortaogretim Kimya Ders Kitaplarini Kullanimlarinin Incelenmesi. *Ahi Evran Universitesi Kirsehir Egitim Fakultesi Dergisi (Ahi Evran University Journal of Kirsehir Education Faculty)*, 10(1), 91-101.
- Nakiboglu, N., & Nakiboglu, C. (2017a). *Investigation of high school students' understanding about electrochemistry concepts*. Paper presented at the *International Conference on Education in Mathematics, Science & Technology*, Kusadasi/Turkey.
- Nakiboglu, N., & Nakiboglu, C. (2017b). Kimya ogretmen adaylarinin elektrokimya kavramlarini anlama duzeylerinin incelenmesi. s.108, Paper presented at *Uluslararası Çağdas Eğitim Araştırmaları Kongresi*, Mugla.
- Ogude, A.N., & Bradley, J. D. (1994). Ionic conduction and electrical neutrality in operating electrochemical cells: pre-college and college student interpretations. *Journal of Chemical Education*, 71(1), 29-34.
- Ogude, A.N., & Bradley, J. D. (1996). Electrode processes and aspects relating to cell emf, current, and cell components in operating electrochemical cells: Precollege and college student interpretation. *Journal of Chemical Education*, 73(12), 1145-49.
- Ozkaya, A. R. (2002). Conceptual difficulties experienced by prospective teachers in electrochemistry: Half-cell potential, cell potential, and chemical and electrochemical equilibrium in galvanic cells. *Journal of Chemical Education*, 79(6), 735-738.
- Rahayu, R. , Treagust, D. F., Chandrasegaran, A.L., Kita, M, & Ibnu, S. (2011). Assessment of electrochemical concepts: A comparative study involving senior high-school students in Indonesia and Japan. *Research in Science & Technological Education*, 29(2), 169-188.
- Sanger, M. J., Greenbowe, T. J. (1997a). Students' misconceptions in electrochemistry: Current flow in electrolyte solutions and the salt bridge. *Journal of Chemical Education*, 74(7), 819-823.
- Sanger, M. J., & Greenbowe, I. J. (1997b). Common students' misconceptions in electrochemistry: Galvanic, electrolytic and concentration cells. *Journal of Research in Science Teaching*, 34(4), 377-398.

- Schmidt, H-J., Marohn, A., & Harrison, A. G. (2007). Factors that prevent learning in electrochemistry. *Journal of Research in Science Teaching*, 44(2), 258–283.
- Taber, K. S. (2013). Revisiting the chemistry triplet: drawing upon the nature of chemical knowledge and the psychology of learning to inform chemistry education. *Chemistry Education Research and Practice*, 14, 156-168.
- Talanquer, V. (2011). Macro, Submicro, and Symbolic: The many faces of the chemistry “triplet”. *International Journal of Science Education*, 33(2), 179-195.
- Yang, E. M., Greenbowe, T. J., & Andre, T. (2004). The effective use of an interactive software program to reduce students’ misconceptions about batteries. *Journal of Chemical Education*, 81(4), 587-595.
- Yildirim, A., & Simsek, H. (2011). *Sosyal Bilimlerde nitel arastirma yontemleri* (8.Baski). Ankara, NY: Seckin Yayınevi.

**Textbooks used in this study**

- Textbook # 1: Yildiz, M. (2017). *Ortaogretim Kimya 12*, Ankara: NOVA Yayıncılık Ticaret Limited Sirketi.
- Textbook # 2: Badur, H. (2016). *12. Sinif Ortaogretim Kimya Ders Kitabı*, Ankara: Evrensel İletişim Yayınları.

# The Village Teacher Training Trials in Turkey, Mahmudiye Instructor Course and Mahmudiye Village Teacher Training School

Ilhan Kulaca, Adil Adnan Ozturk

## 1. Introduction

Before the Balkan War, Anatolia people were tired of war and mobilization orders. Within and after The Balkan War and The First World War, they were plunged into darkness and gave up hope of their future.

Ottoman General Mustafa Kemal Pasha, having achievements in to lots of fronts, was looking for a remedy for liberation with a group of his friends who believed him. As mentioned in Amasya Circular “*independence of the nation’s determination and decision will save the nation*”. After Amasya Circular and Congresses, M. Kemal, came to Ankara on 27 December 1919. Turkish Grand National Assembly; opened on 23 April 1920; founded the regular army. For the struggle, especially against the Greek regular army was the first and the most significant condition for him.

M.Kemal was aware of limited possibilities than inviting the help of suffering Anatolian people who were doomed, poor and ignored for centuries. The idea of founding firstly an army then a young republic that can adapt to the needs of the age was his biggest ideal (Kansu,1968). He gave importance to both the victory of war and the enlightenment of Anatolian people who were abandoned to ignorance. In the course of Kutahya-Eskisehir War, despite all objection, organizing Education Congress in the sign of this.

M.Kemal visited Ismet Pasha who was about to become desperate. He looked at the window and saw the women who had digger, trowel, water jug in their hands and said: “*Let’s get rid of it Ismet*”. When he said that, it was a dream of educated, free from poverty and happy people lived in Turkey (Ozakman,2005).

Lozan Peace Treaty was signed on 24 July 1923. It is historical document which shows that the Ottoman Empire was destroyed and replaced with an Independent Turkey and that it was approved by the powerful states of Europe, Asia, America and especially the victors of the World War (Turan,2012).

Churchill represented M.Kemal as “*the man of the century*”. The war of Independence was won by M.Kemal and self devotion of Anatolian people. As M.Kemal indicated, the real war was started now. He had to fight ignorance and the education system had to be taken care of. Because, it was the main reason which has led the nation to disaster for 300 years. More than 80% of the population lived in the village, so if the villagers did not developed, the country could not develop. Facing village and villagers, at the same time, was a duty of loyalty to Anatolian people who were the most significant part of National Struggle.

Berkes (2016:522) in his work, points out the two aspect of Turkish Society’s modernisation: “*Bringing up the Turkish Society to the trajectory of civilization has two aspects: The first side, which we can see plenty of samples in this book, is to eliminate the traditionalist attitude. The second side, instead, is to establish the rules, to establish the transition bridge between the ages by cultivating the new generations of society according to the needs of this trajectory*”. This relationship could only be established with training. The work that had to be done was not simple of course, but to throw off the centuries backward, especially from the villagers and the nation.

Till 1940s, although important steps were taken in the period, there were many things to get over. According to the population census in 1935, 12.400.952 of the country’s population, namely the 80%, lived in villages. Early 1940s, there were 40.000 villages in Turkey and there was no school in 35.000 of these villages. In 1935, in Turkey, now all senior educators have exhausted their suggestions for the village’s education problem. They were all inconclusive finally, they all came to the same point (Kirby,2015).

In order to save the country from this backward state, someone was needed who knew the country well. This need was solved by bringing Saffet Arikan to Ministry of National Education on 11.06.1935 (Tonguc,1947). The biggest problem to overcome for Saffet Arikan was to bring school and teacher to the villages of the country. For the General Directorate of Primary Education, a qualified person was needed to overcome this. Ismail Hakki Tonguc was a person that Arikan was looking for (Kirby,2015). According to Tonguc, the village issue was not a uniform development, but a conscious revival of the village. The villagers should be relieved of turbaned literate and the village teacher should be replaced. If the village does not develop, the continuity of the regime and reforms can not be ensured. It would disappear before it could reach the society. Tonguc prepared a report to Saffet Arikan. In this report, demographic structures of the villages were discussed and the village teachers were encouraged to be chosen from the village (Tonguc,1947).

The report submitted by Tonguc, directed Saffet Arikan to Mahmudiye. He started the process of opening Mahmudiye Village Training School and Instructor Course which would later become a model to all over the country.

## **2. Material and Methods**

In this study, scanning model is used. For this reason, founded in Mahmudiye, Mahmudiye Instructor Course and Mahmudiye Village Teacher Training School's accesible documents were scanned in the archives. Relevant sources were investigated. Interviews were made up with the students who are alive especially graduated from Cifteler Village Institute. Audio and video records were taken. The school campus has been investigated in some buildings that are still used today. Interviews were made up with the people in Mahmudiye and the contribution of the school to it's environment was investigated. Descriptive analysis method is used to analyze the datas.

## **3. Results and Discussion**

Although 13 years had passed since the proclamation of the Repuclic, no progress has been made on the development and education of the villagers. This situation disturbed those who sought a solution to this situation in Turkey. According to Tonguc (1947), Turkey was a nation for behind Europe in terms of primary education activities in 1934. This problem caused to opening Mahmudiye Village Training School and Instructor.

### **3.1. Mahmudiye Instructor Course**

Minister of Culture Saffet Arikan in 1936, shared his idea that those who would be assigned as teachers to three-class-schools to be opened in villages, should be chosen from the youth who had made their military service as corporal and sergeant. Because it was decided that sergeants and corporals should be chosen from the ones with abilities in terms of their education success and hard work (Basgoz,2016).

The petition number 6/65627, signed by Minister of Culture, General Director of Primary Education, Saffet Arikan on 3 August 1936, was sent to the Prime Ministry. In this petition, permission was requested for the Village Teachers and Trainers Course, which was planned to be opened in the village of Mahmudiye, Cifteler Farm. The instruction includes the basic issues such as the wages and salaries of the agricultural teachers who will take part in the course will be met by the Ministry of Agriculture, the cultural lesson teachers will be charged by the Ministry of Culture, the farm facilities and buildings will be used, and the large staff will be formed in cooperation with the Ministry (Anadolu University,2009).

The opening Mahmudiye Village Teachers and Trainers Course was officially accepted in Decree no 2/5494 on a legal basis by the Law of eight-item Village teachers on 11.06.1937. Thus, the way of employing trainers has been opened to villages whose populations were unsuitable for sending teachers (Koy Egitmenleri Kanun ve Talimatnamesi,1938). One month before the letter which Saffet Arikan sent to the Ministry it is understood from the work of Turkoglu (2017) that the first rehearsal of the course was made. In July 1936, the first trainers were trained in Mahmudiye Village of Eskisehir. Cifteler Studfarm here to be installed, tools and technical staff, training of trainers would benefit who finishes

### The Village Teacher Training Trials in Turkey

this seven-month-course would be named as instructor, not teacher. The Director of the course was also the Director of Cifteler Studfarm, Numan Kirac. 84 participants from the villages of Ankara and Tunceli participated in the course (Tonguc,1947). The second course was opened in 1937, students from the villages of Eskisehir an Afyon began to be taken (Balkir,1968).

The second course was opened in Hamidiye at the same time with Mahmudiye, unlike the first one. The course in Mahmudiye was opened for the first students who did internship and came back, the course in Hamidiye was opened for candidates who would be educated for the first time (Balkir,1968).

The training period of Mahmudiye Instructor Course was limited to seven months. After the first four and a half months of training, students would go to their village for an internship, then return of the internship, was two and a half month more training (Tonguc,1997). The Course were; Arithmetic, Geometry, Homeland and Living Knowledge, Workshop Classes, Education Knowledge (Bayram,1999).

After the Agriculture Congress in 1938, according to a report by the Ministry of Agriculture, Mahmudiye and Cifteler Studfarm were chosen as the horse breeding and agricultural practice field of the country. As a matter of fact, the democratic formation of people, tendency to work together with the studfarm and the hand-to-handedness of people were the reason to be chosen. People in Mahmudiye's contribution to the breeding of animals had great support. Again in those years, Mahmudiye Instructor Course, Cifteler Village Institute who used the lands of Studfarm were in solidarity with the public (Emiroglu and Yuksel,2009).

According to the work of Mahmudiye Village Instructor Course Education Chief S.Edip Balkir (1968), students were separated into groups as Ergenekon, Cankaya, Tinaztepe, Altiok, Sakarya, Gocyolu, Bozkurt, Kocatepe, Inonu. The work of the students before and after the afternoon were determined. Groups alternately participated in Workshops, Course Applications, Construction, Field Agriculture, Culture lesson, Free Reading Activities from 07.00-20.30. A daily run program can be seen in Table 1 and Table 2 below.

**Table 1.** Mahmudiye Instructor Course 11.10.1937 Monday Study Program Before Afternoon

Work	Clusters	Time
Free Reading	All Clusters	07.00-08.00
Workshop	Kocatepe	08.00-10.00
Workshop	Dumlupinar	10.00-12.00
Course Application-Writing	Gocyolu, Bozkurt, Ergenekon	08.00-12.00
Course Application-Writing	Inonu, Sakarya	08.00-12.00

Resource: (Balkir, 1968:193)

**Table 2.** Mahmudiye Instructor Course 11.10.1937 Monday Study Program Afternoon

Work	Clusters	Time
Guard	Altiok	-
Construction	Kocatepe	14.00-17.30
Workshop	Tinaztepe	13.30-15.30
Workshop	Inonu	15.30.-17.30
Zootechnics	Dumlupinar, Sakarya, Gocyolu	14.00-15.30
Canning	Bozkurt, Ergenekon, Cankaya	14.00-15.00
Canning	Dumlupinar, Sakarya, Gocyolu	15.30-17.00
Free Reading and Writing	All Clusters	19.30-20.30

Resource: (Balkir, 1968:194)

As Ozkucur (2015:216) mentioned in his work, although the curriculum seemed to be heavy, the work in the course was not more difficult than the work of village life, all of which were peasant children. Ozkucur: "...Collecting stones, trees, digging up soil and shoveling was farm labourer's job in our village. Those who did this were called as 'worker' Here it is called 'work job' and those who work are called 'students' ". In the second month, the trainees have turned success into an issue of honor and they have gone far

beyond the expected success (Tonguc, 1997). The same effort and efficiency can be seen in Edirne course as mentioned in Bayir's (1971) work. Bayir talks about village teachers with respect and admiration, giving examples to some of these trainers who spend 12 hours of the day working tirelessly.

The campaign for education which started with the schools opened by the graduates of the Instructor Course has increased significantly in the villages of Anatolia over the next 20 years. The contribution of the graduates hasn't only been about teaching illiteracy. For the development of the village, which has been neglected for centuries, they were intended to be guide people to keep up with the age and to keep up with the innovations.

### 3.2. Mahmudiye Village Teacher Training School

The success of Mahmudiye Instructor Course also affected the opening of primary school in Mahmudiye. When the opening dates of the schools in Mahmudiye were examined, the fact that the were equal to 1938 proves this success. At the same time, this succes encouraged Ismail Hakki Tonguc and the Ministry to spread village education to Turkey. In the academic year, Kizilcullu Village Teacher Training School and Eskisehir/Mahmudiye Village Teacher Training School was officially opened on 30.10.1937 in the college which was purchased from the Americans in Izmir. This date was also the beginning of the process of Village Institutes (Tonguc,1997).

The reason that brought Hasan Ali Yucel to Ministry of National Education, whose name was identified with Village Institutes, were formed spontaneously. Saffet Arikan, who worked on Primary Education issues, resigned from the Ministry due to the health problems. Hasan Ali Yucel, became the Ministry of National Education on 28.12.1938. Hasan Ali Yucel has survived this year's grieving period by "*turning pain into work*" (Turkoglu, 2017).

During the first months of the Ministry, Hasan Ali Yucel worked to legalize Village Teacher Training Schools. In 1939, the law no.3704 on the "Administration of Village Instructor Courses and Village Teacher Training Schools" has been enacted (Gedikoglu,1971). Thus, Mahmudiye Village Teacher Training School also had a legal status. Peasant children were admitted from Eskisehir, Konya, Afyon, Ankara, Kutahya province to the school of Mahmudiye Village Teacher Training. When you look at the Cifteler Village Institute diploma book, it is seen that the first graduates are from Eskisehir and Konya. In the selection of students to school, regional selection examination were effective done by the inspectors. In his work Ozkucur (2015) wrote that he was a beekeeper on an islet in Lake Beysehir, and that he attended the exam with malaria and became successful. 30 Turkish Liras entrance money was received from the students who would be admitted (Burgac,2004). Then reduced to 20 Turkish Liras (Apaydin,2017). After the school became Cifteler Village Institute, the registration fee was abolished. Instead, a written engagement was started to be invited from the students' parents. This is understood the written engagement that belongs to Sabri Cicek, the son of Huseyin Cicek, Kilbasan Village in Karaman, 13.07.1940 (Yunusemre Vocational and Technical Anatolian High School Archive).

Education and training activities would start without losing time. The building, which was inherited from American College, gave Kizilcullu an advantage. In Mahmudiye, there was no building to be used, except for the building whose authenticity has been lost today and the primary school building of the Instructor Course. The building shortage was resolved by the construction of a three-storey building in Hamidiye in 1938. In the construction of the building, the Hungarian Construction foreman Sili Layos, the instructor and the students worked. Students had a hard winter until the building shortage was resolved. The Principal Remzi Ozyurek often went to Eskisehir, working day and night to meet the needs of the school (Tonguc,1997). In some of the buildings in Mahmudiye, the first teachers, Ankara Construction Foreman School, villagers, village teachers and the first graders of the school have great support (Koc,2013).

Today both Mahmudiye Public Education Center, Osmangazi University Mahmudiye Horsebreeding Vocational School buildings and Hamidiye Campus buildings were built by the co-operation with teachers and students. So, it was a process that made the education given by the teachers valuable for the students. During this construction process, life-lesson events were experienced.

On the meeting with Ahmet Oztuna (Interview, 23.08.2017, Eskisehir), graduated from Cifteler Village Institute in 1944: *"We set up the dorm, I was carpenter. Sili Layos was our teacher and construction foreman. Barns, sheep pens and so on were made. One day, I was hitting the tree with an adze, unintentionally, absently. Sili came 'what are you doing?' he asked. 'Nothing' I answered. Sili was a Hungarian. He grabbed the wood. 'shoot' he said. 'I don't shoot' I said. He just looked at my face and I understood that he wanted to say 'the materials are valuable, do not harm them'. It was a life-lesson."* By saying these words, he gave information about building construction works and memories about Sili Layos teacher. The experience gained at Mahmudiye Village Teacher Training School, minimized the difficulties that the Cifteler Village Institute would experience.

Mahmudiye Village Teacher Training School was made up of three parts. These were Primary School, Secondary School and Teacher Training School in the Primary School 4. and 5. graders were studying. This was because the fifth grade schools in the villages were a small number graduates of the secondary school. The point that attracts attention here is that the Mahmudiye Village Teacher Training School would receive students after secondary school and Cifteler Village Institute which is the continuation of this school would receive students after primary school (Burgac,2004). Three-class school villages were very common, as we saw in the study of Mahmudiye Primary School archives. The opening of the five-grade primary schools in Mahmudiye was in 1942 and after which the Cifteler Village Institute gave its first graduates. As we mentioned before, the first students Of Mahmudiye Village Teacher Training School, were the first graduates of Cifteler Village Institute at the same time. They worked hard to build the constructions that the school needed. It can be said that, those who came to Cifteler Village Institute after 1943-1944 were more comfortable than the first graduates.

According to the main theme of Ozkucur (2015)'s work, one of the first students of the Mahmudiye Village Teacher Training School, the basic requirements of the school were obtained by the students' work. All the building requirements such as, school, workshops, bath, toilet, tank etc. were done by the students with their teachers. As he said during a meeting with Ilyas Kucukcan (Interview, 06.07.2017, Eskisehir) graduated from Cifteler Village Institute, *"this was job training at work"*.

After Mahmudiye Village Teacher Training School became Cifteler Village Institute, students were educated for two more years and graduated from Cifteler Village Institute. Graduates of 1941-1942, 1942-1943, 1943-1944 were also the students of Mahmudiye Village Teachers Training School. There were also the first students of Cifteler Village Institute in 1944 graduates. They were graduated one year early because of the need of teachers in villages. They were trained for four years. All 33 students graduated in 1942 were sent to Hasanoglan High Village Institute. 57 students graduated in 1943. The whole of these two years were the students of Mahmudiye Village Teachers Training School. 312 students graduated in 1944. As we said before, among them were the first registered students (Kulaca, 2017).

Mahmudiye Village Teacher Training School left useful experiences to Cifteler Village Institute, after it became an Institute three years later. It tried to minimize the difficulties which Cifteler Village Institute would experience. When the Village Institute Law of post-1940 was drafted, psychological and pedagogical experiences gained here, provided idea background to Ismail Hakki Tonguc who visited Mahmudiye Village Teacher Training School for many times.

#### **4. Conclusion**

The revolutionary cadre in the thought of creating a modern society after a state, from the tired nation of the years of National Struggle, have seen that success can not be achieved without the help of the villagers. At the point where all solution proposal were exhausted and Ismet Inonu considered the steps taken for education as a waste of time; Saffet Arıkan and Ismail Hakki Tonguc found a more practical, cheaper and permanent way for the revival of village life and education. The solution was Mahmudiye.

Mahmudiye was not chosen by chance. Proximity to the capital city, ease of transportation, being a form from Ottoman Empire, the advantageous structure of agricultural tools and qualified personnel, Anatolia's typical terrestrial climate, people's adoption of the change and the reforms are some of the reasons that made Mahmudiye special. People's fondness for education gained the appreciation of people who knew the region, especially Rauf İnan and Ismail Hakki Tonguc. Tonguc, at the the school's



sod-turning ceremony in Hamidiye, gave the honor of throwing the first mortar to the villagers of Hamidiye and showed them the respect.

Mahmudiye Instructor Course and Mahmudiye Teacher Training School following it, besides then Cultural lessons of city schools; Agriculture, Fruit growing, Vegetable gardening, Cooking, Poultry Husbandry, Beekeeping, Animal Husbandry, Small Construction, Carpentry, Black Smith, Human and Animal Health Courses and Arts were taught which city schools didn't have. With the authentic programs, the concept of "job training at work" was adopted. The instructors and teachers who were sent to villages went eagerly to the villages where they were born and raised, and they one of the first success of later school in Mahmudiye and other regions was because of this while many of those who grew up in the city and the studied in the city schools wanted to get out of the poor villages where they were assigned as teachers, the graduates of the Village Instructor Course and Village Teachers Training Schools worked as if they were fighting the backwardness in the village.

Even on summer holidays, in the school's construction, in the field, in the vineyard... working students were part of the village enlightenment, one of the most important projects of country development in the middle of the steppe. They established orchard, vineyard and forest in Mahmudiye-Hamidiye bays with the water they carried from Seydi Stream with tins. It is possible to see these trees today. The fact that Mahmudiye Village Teachers Training School's buildings in Mahmudiye are still being used is important in terms of showing the quality of the work done.

These schools, an opportunity for the village children to attend school, contributed to education of many talented village children such as Abdullah Ozkucur, Talip Apaydin, Mustafa Aydogan, Ahmet Oztuna... For example, Yesilyurt Village of Mahmudiye is 60 houses and there are 300 teachers in the village. It means five teachers per household. All of them were educated in Mahmudiye Village Teacher Training School and its continuation schools. Their children and grandchildren are well-educated, qualified people today. In a meeting with Baki Aydin (Interview, 30.07.2016, Yesilyurt Village-Mahmudiye) he said: "how would we attend school without Mahmudiye and Hamidiye?" The material and spiritual traces of Mahmudiye Instructor Course, Mahmudiye Village Teacher Training School are still visible in Mahmudiye and many villages of Anatolia.

#### 4.1. Research Suggestions

The concept of "job training at work" at Mahmudiye Instructor Course and Mahmudiye Village Teacher Training School is model that is needed in Turkish education system today. Because of the examination anxiety, even the science course is taught by solving tests and can not provide permanence in learning. The common result of the Works and interviews studied in the research is that the sense of applied education provides long-term permanence in learning. In Turkish Education System, curriculums should be organized according to this understanding and education should be taken away from the anxiety of examination.

#### 5. References

- Anadolu University. (2009). *Kurtulus ve aydinlanma Eskisehir arxiv belgeleriyle*. Ankara: Basak Matbaacilik.
- Apaydin, T. (2017). *Koy Enstitusu yillari*. Istanbul: Literatur Yayinlari.
- Balkir, S. E. (1968). *Eski bir ogretmenin anilari*. Istanbul: Ari Kitabevi.
- Basgoz, I. (2016). *Turkiye'nin egitim cikmazi ve Ataturk*. Istanbul: Pan Yayıncılık.
- Bayir, F.O. (1971). *Koyun gucu*. Ankara: Ulusal Basimevi.
- Bayram, F. (1999). *Ogrenmeyi ogreten ustalar*, Ankara: Kultur Bakanligi Yayinlari.
- Berkes, N. (2016). *Turkiye'de cagdaslasma*. Istanbul: Yapi Kredi Yayinlari.
- Burgac, M. (2004). *Cifteler Koy Enstitusu*. Unpublished master's thesis. Uludag University Social Sciences Institute, Bursa, Turkey.

The written engagement that belongs to Sabri Cicek, the son of Huseyin Cicek, from Kilbasan Village in Karaman, Cifteler Village Institute 13.07.1940. Yunusemre Vocational and Technical Anatolian High School Archive, Mahmudiye, Eskisehir, Turkey.

## The Village Teacher Training Trials in Turkey

- Emiroglu, K. Yuksel, A. (2009). *Yoldasimiz at*. Istanbul: Yapi Kredi Yayinlari.
- Gedikoglu, S. (1971). *Evreleri, getirdikleri ve yankilariyla Koy Enstituleri*, Ankara: Is Matbaacilik ve Ticaret.
- Interview with Ahmet Oztuna (Interview, 23.08.2017, Eskisehir).
- Interview with Baki Aydin (Interview, 30 Temmuz 2016, Yesilyurt Village-Mahmudiye).
- Interview with Ilyas Kucukcan (Interview, 06 Temmuz 2017, Eskisehir).
- Inan, R. (1977). *50. Yilinda Turkiye Cumhuriyeti ve egitim*. Ankara: Turk Tarih Kurumu Basimevi.
- Kansu, M.M. (1968). *Erzurum'dan olumune kadar Ataturk'le beraber*. Ankara: Turk Tarih Kurumu Basimevi.
- Kirby, F. (2015). *Turkiye'de Koy Enstituleri*. Istanbul: Tarihci Kitabevi.
- Koc, N. (2013). *Turk kultur tarihi icerisinde Koy Enstituleri*. Istanbul: Ideal Kultur Yayıncılık.
- Kulaca, I. (2017). *Cumhuriyet donemi Mahmudiye'de egitim*. Unpublished master's thesis. Adnan Menderes University, Social Sciences Institute, Aydin, Turkey.
- Tarım ve Kültür Bakanlıkları Koy Egitmenleri Yetistirme Kursları Nesriyatı (1938) *Koy egitmenleri kanun ve talimatnamesi*. Istanbul: Devlet Basimevi.
- Ozakman, T. (2005). *Su cilgin Turkler*. Istanbul: Bilgi Yayınevi.
- Ozkucur, A. (2015). *Ogretmen olacagim*. Ankara: Ogretmen Dunyasi Yayinlari.
- Tonguc, I. H. (1947). *Egitim yolu ile canlandirilacak koy*. Istanbul: Remzi Kitabevi.
- Tonguc, E. (1997). *Bir egitim devrimcisi: Ismail Hakki Tonguc (yasami, ogretisi, eylemi)*. Ankara: Guldikeni Yayinlari.
- Turan, S. (2012). *Turk devrim tarihi*. Ankara: Bilgi Yayınevi.
- Turkiye Radyo ve Televizyon Institution (Producer), Ozakman, T. (Scenarist) and Oztan, Z. (Director). (1996). *Kurtulus* [Film]. Turkiye: Turkiye Radyo ve Televizyon Institution.
- Turkoglu, P. (2017). *Tonguc ve Koy Enstituleri*. Istanbul: Turkiye Is Bankasi Yayinlari.
- Yunusemre Vocational and Technical Anatolian High School Archive.



# Learning Analytics In Open And Distance Education: Advantages And Disadvantages

Nilgun Tosun, Gulsun Kurubacak

## 1. Introduction

MOOC (Massive Open Online Courses) contains big data in many formats on many students, registered in OYS (Student Placement Examination) and social networks. Hence, it is necessary to evaluate the collection, storage, processing, security of the data as well as the ethical approach. Another point that draws attention is the necessity to determine the extent to which the material investments spent for the open and distance learning platform, the content or design updates are effective on the development of qualifications of the teaching staff. In order to fulfill this requirement, data obtained from students and called "big data" need to be analyzed by unordinary statistics and processes. At this point, the application area, which is called as learning analytics and deals with the analysis of big data, gains prominence. In this study, learning analytics will be defined first and tools for learning analytics in open and distance-learning platforms will be mentioned. Then, the advantages and disadvantages of the learning analytics in open and distance learning environments will be revealed and recommendations for the learning analytics will be shared. We believe that this information and recommendations would be useful for decision makers, researchers as well as practitioners working in this field.

## 2. Learning Analytics

The Society for Learning Analytics Research defines the learning analytics as the collection, measurement, analysis, and reporting of data about learners and their contexts (SoLAR, 2014). According to another definition, learning analytics refers to the measurement, collection, analysis, and reporting of data about students and their contexts in order to understand and optimize the learning and the environments in which day study (Long and Siemens, 2011). It is within the context of learning analytics that learning and analyzing big data, developing new tools and techniques, revealing patterns in storage and big data, symbolizing the obtained data in a generalized and functional way, and finally, improving and personalizing learning processes (Martin and Sherin, 2013). According to the definition mentioned in the NMC Horizon Report (2016), learning analytics is an educational application of web analytics, aims to collect and analyze individual student interactions and create learners' profiles in online learning activities.

Learning analytics is used to obtain useful information for learners, to reflect learners' previous learning experiences and to improve teaching as well as learning (Dyckhoff et al., 2012). According to Shum (2012), questions about how to analyze learning data and the development of learning systems based on the evidence can only be answered with learning analytics since there is not much descriptive analysis.

It is important for learners studying in open and distance learning programs to organize their own learning, to present personalized learning materials and activities in support of this structure, and to provide for learning analysis. In addition, there is a need for learning analytics to help individuals successfully complete the learning process, to improve the quality of learning, and thus to recruit more learners in open and distance learning programs.

Dawson and Siemens (2014) advocate that learning analytics is a field integrating research and methods on data mining, social network analysis, information visualization, machine learning, psychology, semantics, artificial intelligence, e-learning, learning theory as well as the practice. In other words, learning analytics is an area of application that requires inputs from many disciplines.

### 3. Environments and Tools Used for Learning Analytics

Learning analytics can take different names depending on the purpose of the study. According to Stein (2012), there are five types of learning analytics. These are student-centered analytics, learning-centered analytics, classroom or community analytics, program evaluation analytics, and corporate analytics. Whatever their type is, learning analytics require an interdisciplinary work and takes a long time to complete, have a three-stage structure. The formation of this structure benefits from 4 main sources. The cycle and structure of learning analytics are as shown in Figure 1 (Elias, 2011).

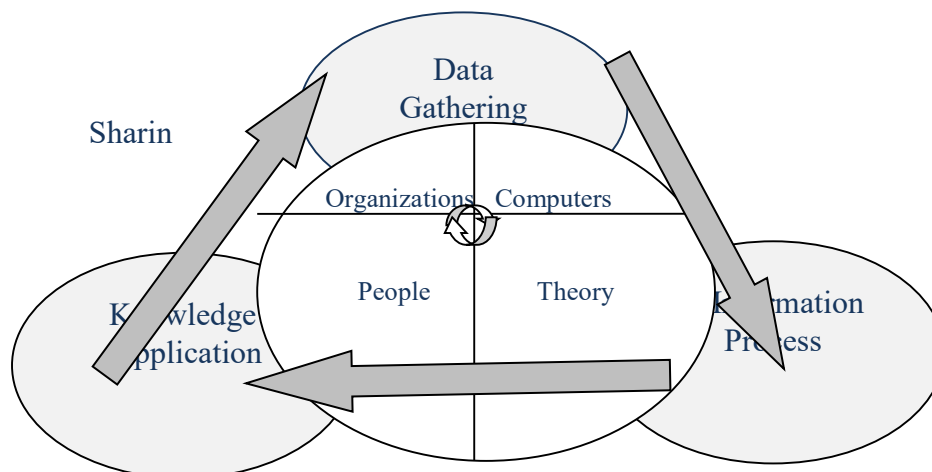


Figure 1. The cycle and structure of learning analytics

According to Figure 1, the cycle of learning analytics consists of 3 steps. In the first stage, the data to be collected are determined and these data are collected from appropriate media using suitable methods. In the second stage, the data are classified according to their particular characteristics and data were converted to the information. In light of this information, the estimations are prepared. For example, it is possible to estimate in which class a student may be successful, or the drop rates or the type of materials that the student might choose. In the third stage, redundant information is cleansed for evaluating and improving the system with meaningful information. This information is then integrated into the system. Finally, this information is reported and shared so that other stakeholders of the system may benefit from them. This realization of this cycle is achieved by the contribution and interaction of the four main components. Hence, at the heart of learning analytics lay the institutions that need evaluation and improvement, the learners, decision makers and educators involved in these institutions, the computers for analysis and the various theories that will form the foundation for analysis and improvements.

For the cycle of learning analytics, a set of data must be collected using appropriate means from different environments. Learning analytics according to Dawson and Siemens (2014); use data related to the interaction of a learner with content, other learners, and educational institution in order to make decisions and evaluations about learning practices, personalized content, and interventions that are necessary for students' achievement. While Shaffer et al. (2009) state that social networking and epistemic network analysis may be used as the learning analytics, Baker, D'Mello, Rodrigo, & Graesser (2010) advocate that emotional characteristics of the learners may be used as the learning analytics. Ifenthaler and Widanapathirana (2014) emphasize the use of diverse data such as psychometric tests, socio-demographic data about the student's previous information, learning strategies and competencies when learning analytics is being conducted. In addition, external data such as all characteristics of the student, including previous academic performance, searches in the library catalog, geographical data, or information from social media can be included in the learning analytics. The curriculum information about the style of study and learning objectives, the traces generated by the learning management system (the time spent online, frequency and duration, discussions and other

online interactive activities, the result of the personal evaluations, etc.) should be integrated into the analysis of formal learning environments. On the other hand, Khalil and Ebner (2016) stated that data mining techniques are the most used method for analyzing and interpreting daily data of students while ranking the method tools used for collecting and analyzing data in learning analytics. For example, the decision tree algorithm can be used for predicting performance degradation and lesson performance of a student in a virtual learning environment (Wolff et al., 2013). At the same time, the trees strive to detect student behaviors and determine if the students spend time online out of purpose (Pardos et al., 2013). On the other hand, statistics and mathematics are used for the numeric representation of the data obtained as well as the realization of the analysis in many techniques and data mining. Another analytical tool is the ontologies. These are text mining, discourse analysis, natural-language processing or language studies and text analysis, semantic and linguistic analysis categories tools (Khalil and Ebner, 2016). These tools are the most commonly used in the analysis of content such as the messages of students with each other, their messages to teachers, questions, answers, comments posted to the forums. Visualization is another analytical tool. Sometimes, it may be hard to examine a large amount of numeric data belonging to one or many students and hence, to decide. It may take a long time. It may be challenging to decide. Hence, it would be easy to summarize the data with visuals such as graphics, flowchart, and diagram and this will facility the analysis of the data as well. One of the most used methods in learning analytics is social network analysis. It is used for monitoring the students' behaviors in the networks and social networking environments, recording them and determine the underlying causes of the students' behaviors. Thus, Ferguson (2012) stated that social network analysis used within the context of learning analytics could be utilized to encourage collaborative learning and to explore the connections between learners, teachers as well as the resources. Qualitative analysis is another method used in the learning analysis. It aims to describe the research topic by capturing the behavior, thoughts, feelings or emotions of the person in detail and in a sophisticated way. In such analysis, different techniques can be used for a systematic analysis. For example; interviews, observation forms, videos, photos, etc. The collected data by using these techniques are divided into categories and the content is analyzed. Hence, we strive to explain the learning of the individual by using categories such as learning behaviors, learning strategies, interests as well as emotions (Glaser-Zikuda, 2012). Another method that has been included in the scope of learning analytics in recent years is the gamification. This method, which is used to render learning and teaching effective and enjoyable, benefits from graphs, progress bars, and scoring tables so that the students spend more time in the system, improve their performance and track their progress.

#### **4. Advantages of Learning Analytics on Open and Distance Learning**

Learning analytics aims to evaluate and improve many aspects of learning at an institutional level, with the help of a large amount of data collected via various mediums, methods, and tools. Macfadyen and Dawson (2010) used LMS (Learning Management System) data to predict the academic performance of the students. On the other hand, Greller and Drachler (2012) emphasize the benefit of learning analytics that would bring if we provide more personalized learning environment so that the students would have more effective learning experiences. In addition, Norris and Baer (2013) examined the learning activities of the students on the learning management system as well as the learning interactions obtained from the participation of the students. On the other hand, some researchers classify the benefits of the learning analytics at various levels. While Shum (2012) classifies these levels as micro, meso, and macro, Ifenthaler and Widanapathirana (2014) classify these levels as mega (governance), macro (institution), meso (curriculum, teacher/educator) and micro (learner). Khalil, Taraghi & Ebner (2016) discussed the benefits of the learning analytics in different dimensions and stated:

- *Prediction*: It is often used to predict when a participant is expected to drop from an online course. This could be done by analyzing a student behavior, exam performance, and video skips. Storing numerous records of previous students' activities based on specific modules help researchers predict the prospective action, such as dropping out of a course or detecting students, who are at

risk. Furthermore, learning analytics can be used to predict the performance and motivation of the students.

- *Recommendations*: These are general suggestions. For example, a MOOC provider may recommend learning materials to students based on their previous registered courses. These recommendations can also be generated to suggest a student answering a specific question in discussion forums.
- *Visualization*: Learners participate in many activities in online learning environments such as MOOC, LMS. Navigations, clicks, answering the questions, downloading files, etc. There are so many interactions; hence, the size of this data is so large. Presenting the data by visualizing them supports awareness, reflection, and sense-making. At the same time, the visualization facilitates many tasks such as analyzing and creating a model for the ones providing education services.
- *Entertainment*: Gamification can be used a learning analytics techniques, particularly at business places. Badges, reward points, progress bars or colorful gauges constitute some prominent elements of learning analytics.
- *Benchmarking*: Refers to a learning process which evaluates courses, videos, assignments, and MOOC platforms are attainable using learning analytics. Hence, it is possible to identify the learning difficulties as well as weak points in the online courses or stalling segments in video lectures. Accordingly, constructive feedback is generated for the development of the educational system.
- *Personalization*: Learners can shape their personal experience in a MOOC. For example, a student can favorite a part of a video and use it. Or may bookmark an article or a document. Furthermore, a student may customize notifications and add comments in videos. All these experiences help the student to develop a personal learning style.
- *Enhance Engagement*: When design improvements to be performed in MOOC platforms are realized in line with learning needs, the participation in the system will spontaneously increase.
- *Communication Information*: Learning analytics collects data from various sources and processes them. This information can also be presented as a report to different MOOC stakeholders. Similar to web analytics, students can check their activities and review learning behaviors and statistics. Furthermore, teachers and decision makers can build an overview about MOOC using these statistics.
- *Cost Saving*: Since learning analytics provide tools of data analysis, it opens the doors for a broad examination possibility, which makes it possible to determine the weak sections of a MOOC. Accordingly, decision-makers can allocate resources effectively and with minimal costs.

According to Harmelen and Workman (2012) learning analytics bring many benefits such as identifying at-risk students, designing appropriate interventions for keeping them in the system, providing recommendations related to the reading materials and learning activities, defining pedagogical improvement needs and evaluating the results, evaluating and adapting the course proposals from students, supporting the teachers in need of teaching methods and assisting the students in the recruitment process.

Because of all these advantages and benefits that have been experienced and expressed, learning analytics contribute to generating more effective outcomes in comparison with the standard analysis in terms of evaluation, improvement and personalized learning dimensions for the learners as well as the institutions, who are providing open and distance learning services.

## **5. Disadvantages of Learning Analytics on Open and Distance Learning**

The investigations reveal the benefits of learning analytics as well as some disadvantages and limitations. Papamitsiou and Economides (2014) emphasize some weak points of learning analytics in their work. For example, misinterpretation of results because of human decision-making factors is one of the weak points in learning analytics. Hence, it would be useful to focus on the reports that were issued before the decision phase, not on the decisions made. Since heterogeneous data sources are utilized in learning analytics, a dictionary to define the data as the representation is not yet available.

Therefore, the problem of data representation is another weak point of learning analytics. It is observed that learning analytics often include quantitative research and its results. Qualitative research only constitutes a minority. On the other hand, Khalil, Taraghi & Ebner (2016) listed the disadvantages of the learning analytics as follows:

- *Security*: The personal and academic information of the students are the most particular data in the databases that belong to learning analytics applications. Unfortunately, the institutions do not always consider maintaining the configuration of this database. Hence, breaches of confidential information are possible to happen.
- *Privacy*: MOOC datasets may hold sensitive information such as e-mails, names or addresses. This information may be disclosed because of learning analytics. This reveals the unauthorized disclosure of personal data, which constitutes an undesirable and sensitive condition.
- *Ownership*: Questions related to "who owns the analyzed data of MOOCs" are commonly heard. Participants, registered on MOOC platforms, like to keep their information confidential, but at the same time, consent policy is essential to ensure transparency.
- *Consent*: Related to ownership of data. Not every MOOC provider clearly declares the usage of students' data. However, policies within the legislative framework should be established. These policies should clarify the rules about the collection of data, the usage (for research purposes or third party information selling).
- *Transparency*: When learning analytics is applied to MOOCs, providers need to disclose their approach to collecting, analyzing and using of participants' data.
- *Storage*: As it is already known, MOOCs are all open to the public. Anyone interested can follow classes without any prerequisites. Hence, the problem of storing big data emerges. Storing big data could be costly, and complex as well as hard to manage.

Again, in this study, researchers, analysts, or managers emphasize that it is possible to trigger the *false positives*, by the generalization of data obtained from a small group of students on a MOOC. For example, if a group of students is "spending unnecessarily in the system" and an analyst builds a prediction model for all students based on MOOC indicators fulfillment, then a false positive action is triggered. Another point that has been emphasized by the researchers is that analytics could fail and thus, mistaken interventions and predictions occur. Failures could happen during the main processes of learning analytics cycle. Wrong actions in collection data form MOOC's, errors in processing or filtering and mistaken interpretation of data are unwanted cases in learning analytics. These mistakes may be accidental and not intentional; this may be beneficial for some stakeholders and may lead to dangerous consequences for the MOOCs.

## 6. Conclusion and Recommendations

Learning Analytics is an interdisciplinary field of application. One of the areas where the application of learning analytics is needed is open and distance learning. Learners in open and distance learning perform learning activities and a set of interactions electronically and leave behind some electronic traces after each action. These traces are a prominent source of data for enhancing learners' academic performance, estimating prospective academic steps, improving open and distance learning platforms, and testing teaching competencies as well. Analyzing large amounts of data from learners containing millions of numbers, using traditional methods makes it challenging to get answers to some questions. Hence, the use of learning analytics seriously supports the decision makers and practitioners in achieving the desired objectives. Despite all the positive aspects, some questions and problems in the implementation of learning analytics still exist:

- Although the confidentiality of personal information is very popular nowadays, it is not yet clarified which personal information would be used in the learning analytics and how to avoid including this mistaken information in analysis and reporting. In addition, there is no standard commitment for institutions to comply with, on what information will be shared, for which purposes and how the information of learners will be shared and with which stakeholders.
- Two of the mediums that the learning analysis uses to collect data are the web and social networks. If all the interactions of the learners, such as all the clicking, navigating, commenting, messaging,



content creating, sharing, constitute the basis of data for learning analytics, how will these data be filtered in the context of personal rights and freedoms without interfering with the personal lives of the learners? There is no standard set in this respect.

- Therefore, a series of ethical rules should be urgently drafted regarding the collection, classification, processing, reporting, storage, and sharing of personal data to be used in the learning analysis. Furthermore, there is an absolute need for corporate institutions that would both determine the legal responsibility against the learners and the ethical rules.
- In addition, learning analytics require significant financial power in terms of costs. The collection, archiving, retention and storage of data will bring financial burdens to institutions.
- Certainly, a significant factor in generating successful outcomes from learning analytics is the human resource. Nevertheless, education programs should be initiated for training the individuals to develop competencies and skills required for using learning analytics techniques and tools, and relevant current programs should be updated accordingly.

## 7. References

- Baker, R.S.J., D'Mello, S.K., Rodrigo, M.M.T., & Graesser, A.C. (2010). Better to Be Frustrated than Bored: The Incidence, Persistence, and Impact of Learners' Cognitive-Affective States during Interactions with Three Different Computer-Based Learning Environments. Retrieved from <http://www.learnlab.org/uploads/mypslc/publications/bdrg-ijhcs-final.pdf>
- Dawson, S. and Siemens, G. (2014). Analytics to literacies: The development of a learning analytics framework for multiliteracies assessment. *IRRODL*, Vol 15, No 4, Sept./14.
- Digital in 2018. Digital Around the World in 2018. Retrieved from <https://wearesocial.com/blog/2018/01/global-digital-report-2018>
- Dyckhoff, A. L., Zielke, D., Bultmann, M., Chatti, M. A., & Schroeder, U. (2012). Design and implementation of a learning analytics toolkit for teachers. *Educational Technology & Society*, 15 (3), 58–76.
- Elias, T. (2011). Learning Analytics: Definitions, Processes and Potential. Retrieved from <http://learninganalytics.net/LearningAnalyticsDefinitionsProcessesPotential.pdf>
- Ferguson, R. (2012). Learning analytics: drivers, developments and challenges. In *International Journal of Technology Enhanced Learning*, 4(5-6), 304-317.
- Glaser-Zikuda, M. (2012). Q-learning. N. Seel (Ed.), In the *Encyclopedia of the Sciences of Learning*. London, Springer.
- Greller, W. and Drachslrer, H. (2012). Translating learning into numbers: A generic framework for learning analytics. *Educational Technology & Society*, 15(3), 42-57.
- Harmelen, M. V. and Workman, D. (2012). Analytics for learning and teaching. *Centre for Educational Technology & Interoperability Standards*, Vol. 1, No. 3.
- Ifenthaler, D. and Widanapathirana, C. (2014). Development and validation of a learning analytics framework: Two case studies using support vector machines. *Technology, Knowledge and Learning*, 19(1-2), 221-240.
- Khalil, M. and Ebner, M. (2016). What is learning analytics about? A survey of different methods used in 2013-2015. In *Proceedings of the Conference: Smart Learning Conference, At Dubai, UAE*.
- Khalil, M., Taraghi, B., & Ebner, M. (2016). Engaging learning analytics in moocs: the good, the bad, and the ugly. In *Proceedings of the International Conference on Education and New Developments 2016, Ljubljana, Slovenia*. Retrieved from <https://arxiv.org/ftp/arxiv/papers/1606/1606.03776.pdf>
- Long, P. D. and Siemens, G. (2011). Penetrating the fog: Analytics in learning and education. *Educause Review Online*. Retrieved from <http://www.educause.edu/ero/article/penetrating-fog-analytics-learning-and-education>
- Macfadyen, L. and Dawson, S. (2010). Mining LMS data to develop an “early warning system” for educators: A proof of concept. *Computers & Education*, 54(2), 588-599.

- Martin, T. and Sherin, B. (2013). Learning analytics and computational techniques for detecting and evaluating patterns in learning: An introduction to the special issue. *Journal of the Learning Sciences*, 22(4), 511-520.
- Moodle (2017). Moodle Statistics. Retrieved from <https://moodle.net/stats/>
- NMC Horizon Report (2016). 2016 Higher Education Edition, New Media Consortium. Retrieved from <https://www.nmc.org/publication/nmc-horizon-report-2016-higher-education-edition/>
- Norris, D. M. and Baer, L. L. (2013). Building organizational capacity in analytics. Retrieved from <http://www.educause.edu/ir/library/pdf/PUB9012.pdf>
- Papamitsiou, Z. and Economides, A. (2014). Learning analytics and educational data mining in practice: A systematic literature review of empirical evidence. *Educational Technology & Society*, 17 (4), 49–64.
- Pardos, Z. A., Baker, R. S., San Pedro, M. O., Gowda, S. M., & Gowda, S. M. (2013). Affective states and state tests: Investigating how affect throughout the school year predicts end of year learning outcomes. In *Proceedings of the Third International Conference on Learning Analytics and Knowledge*, 117-124.
- Shaffer, D.W., Hatfield, D.L., Svarovsky, G.N., Nash, P., Nulty, A., Bagley, E.A., Frank, K. (2009). Epistemic network analysis: a prototype for 21st century assesment of learning. *International Journal of Learning and Media*. 1(1), 1-21.
- Shah, D. (2018). By The Numbers: MOOCS in 2017. Retrieved from <https://www.class-central.com/report/mooc-stats-2017/>
- Shum, S.B. (2012). Learning analytics. Policy Brief, UNESCO Institute for Information Technologies in Education. Retrieved from [http://iite.unesco.org/files/policy\\_briefs/pdf/en/learning\\_analytics.pdf](http://iite.unesco.org/files/policy_briefs/pdf/en/learning_analytics.pdf)
- SoLAR, (2014). Society for Learning Analytics Research. Retrieved from <http://www.solaresearch.org>
- Stein, Z. (2012). Learning Analytics and The Learning Sciences. Retrieved from <https://sites.ewu.edu/instructionaltech/2012/07/31/eli-learning-analytics-and-the-learning-sciences/>
- Wolff, A., Zdrahal, Z., Nikolov, A., & Pantucek, M. (2013). Improving retention: predicting at-risk students by analysing clicking behaviour in a virtual learning environment. In *Proceedings of the Third International Conference On Learning Analytics And Knowledge* (145-149).



# Beyond Boundaries: A Critical Analysis of Paradigms in Educational Research

Zeynep Gulsah Kani

## 1. Introduction

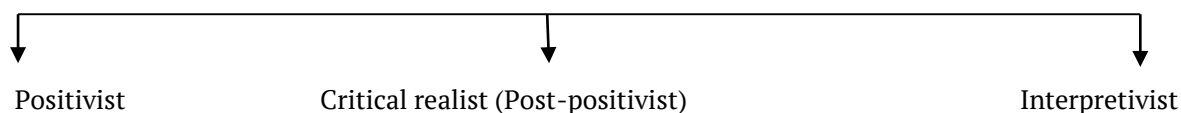
Different from laypeople's loose, unsystematic and uncontrolled concern with the search for truth, scientists with any grips of the world from the beginning of the Aristotelian deduction -syllogism- or Baconian induction to Foucauldian discursive practice consciously acquire a rigorous endeavour: *research* on a multiple and complex occurrence from nature to people's problems (Cohen et al., 2007). This endeavour is shaped according to different understandings of the reality and knowledge in different disciplines. To illustrate from applied linguistics, van Lier (1990 cited in Nunan, 1992) points out that 'controlling or watching space' may change according to the degree of (non-)intervention and (non-)selectiveness as research dimensions. Such technical differences at the level of methods are the visible end of a continuum that spring from different underlying assumptions specifying quantitative and qualitative research; however, instead of presenting an either-or definition with a binary distinction between them, which may lead to a naive oversimplification, I shall locate Nunan's (1992: 3) definition of *research* which encompasses sine-qua-non elements for any form in this context: "a systematic process of inquiry consisting of three elements or components: (1) a question, problem, or hypothesis, (2) data, (3) analysis and interpretation of data". Furthermore, Marshall and Rossman (1999: 21) describes it specifically for the social scientist or the researcher in applied fields as "a process of trying to gain a better understanding of the complexities of human experience, and in some genres of research, to take action based on that understanding".

In parallel to the umbrella definitions of research above, Ernest (1994: 8) basically defines *educational research* as "systematic inquiry with the aim of producing knowledge". It is a branch of an applied social science (Punch, 2009) whose aim is to improve educational critical action, inform understanding of phenomena (Bassey, 1999) or to describe, explain, generalise and predict hypotheses in educational settings. The assumptions underlying these different aims and understandings of the reality (ontology) and knowledge (epistemology) leading to different research methods (methodology) is essentially what is meant by a 'paradigm'. Guba (1990 cited in Creswell, 2007) posits that a paradigm or worldview is "a basic set of beliefs that guide action". Some writers refer to them as meta-theories (Punch, 2009), knowledge claims (Creswell, 2003), methodologies (Cohen et al., 2007) or theoretical perspectives, philosophical assumptions, epistemologies and ontologies (Crotty, 1998).

## 2. Research paradigms and blurring boundaries

When I first started to engage with research paradigms -- that is, our understanding of *what* one can know about something (ontology) and *how* one can gather knowledge about it (epistemology) (Grix, 2004: 78) -- I saw that these are inherent in every single approach to the study of society. My endeavour to locate my educational research studies in the social sciences amidst the bewildering array of -isms frequently used in academia led me to adopt a critical-realist (post-positivist) position between positivism and interpretivism (ibid.). While these positions are often labelled differently, which makes the discourse on the topic confusing, any form of categorisation is likely to be imprecise and leave out more than it contains. Nevertheless, I set out below the three positions on a continuum, as Grix did (2004: 78): as we move from left to right (from positivist to interpretivist positions), we go from approaches attempting to 'explain' social reality to those seeking to 'interpret' or 'understand' it:

Explanation Understanding



**Figure 1** The key research paradigms

These categories are broad and overlapping, and the clear distinction between ‘explanation’ and ‘understanding’ should only be taken as a guide, since many interpretivists seek to explain and positivists would hope their analyses help us understand social phenomena. Considering this initial graphic overview of the perspectives aligned within their respective paradigmatic research traditions, I find it useful to commence with a brief outline of these research paradigms to show how I arrived at the particular paradigmatic position beyond the binary thinking.

Research paradigms, or meta-theories, are important to understand the assumptions underpinning our research, as “meta-theory is a central feature in all planning of social science study. Therefore, there should always be a clear connection between the ontological and epistemological starting points and the practical research work” (Danermark et al., as cited in *ibid.*: 79). To begin with, the assumptions underlying research are both ontological and epistemological. Also, we need to be aware of, and understand, that different views of the world and different ways of gathering knowledge exist (Grix, 2004: 65). Moreover, there is a directional relationship between ontology, epistemology, methodology, methods and sources - the key building blocks of research, as Grix (2004: 66-68) explains:

By setting out clearly the interrelationship between what a researcher thinks can be researched (her ontological position), linking it to what we can know about it (her epistemological position) and how to go about acquiring it (her methodological approach), you can begin to comprehend the impact your ontological position can have on what and how you decide to study.

However, this directional relationship between key components of research does not mean that one component *determines* the other. For example, choosing an ontological position close to that favoured by positivism does not mean your epistemological position will automatically be positivist (Marsh and Furlong, as cited in *ibid.*: 68). Also, as Grix highlights (2004: 89), “there is nothing logically wrong in combining certain ontological and epistemological positions: for example, a realist epistemology with interpretivism”. He also suggests that much of the best research goes on at the borders between the paradigms which are not clear-cut (*ibid.*: 89-98). First and foremost, all research starts from a person’s view of the world, which itself is shaped by the experiences she brings to the research process. Then a researcher’s methodological approach, underpinned by and reflecting specific ontological and epistemological assumptions, represents a *choice* of approach and research methods adopted in a given study (Grix, 2004: 78).

Broadly speaking, there are two contrasting ontological and epistemological positions contained within the research paradigms: positivism and interpretivism. Generally, the former has a foundationalist ontological position that asserts that “social phenomena and their meanings have an existence that is independent of social actors”, while the latter is an anti-foundationalist ontological position that asserts that “social phenomena and their meanings are continually being accomplished by social actors” (Bryman, as cited in *ibid.*: 61). Positivism is “an objectivist epistemological position that advocates the application of the methods of the natural sciences to the study of social sciences and beyond” (Bryman, as cited in *ibid.*: 64). The latter, on the other hand, can be seen as a constructivist epistemological position that “is predicated upon the view that a strategy is required that respects the differences between people and the objects of the natural sciences and therefore requires the social scientist to grasp the subjective meaning of social action” (*ibid.*).

Since the 1970s, critical realism has become a powerful alternative to both positivism, with its search for regular laws, and interpretivism, with its emphasis on “the interpretation of meaning” (Sayer, as cited in Grix, 2004: 85). It neither undermines absolutism (“truth is always true in every situation”) nor supports relativism (“whose to say what is true?”) with its belief in a reality independent of human cognition (Garrison, 2001: 519). This is because “critical realism straddles both positivist and interpretive paradigms, sharing a foundationalist ontology with positivism and allowing for

interpretation in research” (Grix, 2004: 86). The following offers an outline of critical realism, which can be boiled down to these core premises (Grix, 2004: 86):

1. A critical realist approach believes that while social science can use the same methods as natural science regarding causal explanation (in line with positivism), it also needs to move away from them by adopting an interpretive understanding (Sayer, 2000: 17).
2. Critical realists, unlike interpretivists, generally seek not only understand but also to explain the social world.
3. Critical realists conceive of social change and conflict in society as not always apparent or observable, believing that “the immediately perceived characteristics of objects, events, or social relations rarely reveal everything” (Neuman, 2000: 77), i.e. we need to look beyond the surface.
4. Furthermore, critical realists believe in a ‘structured’ or ‘stratified’ reality which requires a “depth ontology” (explained in 2.1) and the interpretation of causal links not always observable in order to offer a fuller explanation of an event, object, social relations etc.
5. According to critical realists, “all human agency occurs and acquires meaning only in relation to already preconstituted, and deeply structured, settings” (Hay, 1995: 200). That is, pre-existing structures affect and are affected by actors.
6. Critical realists tend to distinguish between *efficient causes* (actors) and *material causes* (social structures), suggesting that both represent causal forces: the first by initiating action and the second by constraining or facilitating such action (for an excellent account, see Lewis, 2002: 17-23).
7. Crucially, critical realism is compatible with a wide range of research methods and suggests that the choice of which method to employ should depend on the nature of the object of study and what we want to learn about it (Sayer, 2000: 19).
8. Finally, many critical realists, unlike positivists, acknowledge the double hermeneutic as a means of understanding society, social actors and *their* perceptions of *their* role or position in society.

This position retains an ontological realism (there is a real world that exists independently of our perceptions, theories, and constructions) while accepting a form of epistemological constructivism and relativism (our *understanding* of this world is inevitably a construction from our own perspectives and standpoint) (Sayer, as cited in Maxwell, 2012: 5), as explained in sections below. Frazer and Lacey (as cited in *ibid.*: 5) put it in this way: “Even if one is a realist at the ontological level, one *could* be an epistemological interpretivist . . . our knowledge of the real world is inevitably interpretive and provisional rather than straightforwardly representational”. As Maxwell (2012: 5) stated, “this position has achieved widespread, if often implicit, acceptance as an alternative both to naïve realism (that this reality can be readily accessed) and to radical constructivist views that deny the existence of any reality apart from our constructions.” Shadish, Cook, and Campbell (2002: 29 cited in *ibid.*: 6) argued that “all scientists are epistemological constructivists and relativists” in the sense that they believe that “*both* the ontological world and the worlds of ideology, values, etc. play a role in the construction of scientific knowledge” .

## 2.1 Ontological realism

In Roy Bhaskar’s *A Realist Theory of Science*, reality is described in a stratified ontology that includes three domains: the empirical, the actual, and the real (Bhaskar, 1975/2008). The domain of the empirical is intended to be a subset of the domain of the actual, which in turn is a subset of the domain of the real (*ibid.*) Bhaskar defended an ontological distinction between scientific laws depending upon the existence of “natural mechanisms” and patterns of events that these mechanisms generate. He asserted that:

It is only if we make the assumption of the real independence of such mechanisms from the events they generate that we are justified in assuming that they endure and go on acting in their normal way outside the experimentally closed conditions that enable us to empirically identify them” (*ibid.*: 13).

Similarly, he explained the relationships between mechanisms, events and experiences as follows:

Events must occur independently of the experiences in which they are apprehended. Structures and mechanisms then are real and distinct from the patterns of events that they generate; just as events are real and distinct from the experiences in which they are apprehended. Mechanisms, events and experiences thus constitute three overlapping domains of reality, viz. the domains of the *real*, the *actual*, and the *empirical*" (ibid.: 56).

According to this, "mechanisms, events and experiences" are real; "events and experiences" are actual; and that "experiences" are empirical.

A critical realist ontology can basically be understood as follows: "Natural-social reality exists, absolutely or relatively, independently of our ability to describe it and cannot be reduced to discourse, nor is it merely contained or constructed in the semiotics of our speech" (Sewel, as cited in Wilkinson, 2013: 433). That is, "natural-social reality means that humanity's social being is natural and nature's being is also – at least in part – socially constructed" (Castree & Macmillan, as cited in ibid.). Moreover, "the findings of natural science are themselves social constructions and human interpretations, albeit a particular form of such constructions and interpretations" (Crotty, 1998: 57-71). Therefore, as Crotty (1998: 63) points out, "to say that meaningful reality is socially constructed is not to say that it is not real".

This is further illustrated through the following examples (Wilkinson, 2013: 433):

That being does not equal knowing is proved by the fact that the globe did not suddenly change shape when it was discovered not to be flat and neither did the experience of living on it and many other similar examples (Bhaskar, 2000). An extension of this is that beings, entities and phenomena can exist without being known or even if there is no possibility that they can come to be known (Bhaskar 1975/2008).

Norris stated that "where the anti-realist goes wrong, the realist will claim, is in confusing ontological with epistemological issues" (as cited in Maxwell, 2012: 12-13). The conflation of ontology and epistemology has been rejected by critical realists, and this taxonomic and causal reduction of being to knowing has been referred to as the "epistemic fallacy" (Scott, 2000: 3).

## 2.2 Epistemological relativism

Critical realism characterises the following key assumptions epistemologically:

1. Our knowledge of the world is fallible and theory-laden. Concepts of truth and falsity fail to provide a coherent view of relationship between knowledge and its object. Nevertheless knowledge is not immune to empirical check and its effectiveness in informing and explaining successful material practice is not mere accident.
2. Knowledge develops neither wholly continuously, as the steady accumulation of facts within a stable conceptual framework, nor discontinuously, through simultaneous and universal changes in concepts.
3. Social phenomena such as actions, texts and institutions are concept dependent. We not only have to explain their production and material effects but to understand, read or interpret what they mean. Although they have to be interpreted by starting from the researcher's own frames of meaning, by and large they exist regardless of researchers' interpretation of them.
4. Science or the production of any kind of knowledge is a social practice. For better or worse (not just worse) the conditions and social relations of the production of knowledge influence its content. Knowledge is also largely- though not exclusively- linguistic, and the nature of language and the way we communicate are not incidental to what is known and communicated. Awareness of these relationships is vital in evaluating knowledge (Sayer, as cited in Easton, 2010: 119-120).

As a consequence, critical realists accept that "our world (reality) is, of course, socially constructed but argue that this is not entirely the case. They construe rather than construct. Reality kicks in at some point" (Easton, 2010: 122). Considering the stratified ontology that Bhaskar (1975/2008) has suggested, Easton makes a well-grounded explanation (ibid.: 123):

The empirical domain is where observations are made and experienced by observers. However, events occur in the actual domain and may be not observed at all or may be understood quite

differently by observers. There is a process of interpretation that intervenes between the two domains. Events occur as a result of mechanisms that operate in the real domain. It is not the case that the real or actual cannot be observed but simply that it may not always be capable of being observed. We see just the tip of an iceberg but that doesn't mean that the invisible three-quarters is not there or is unconnected to what we see.

Critical realism shows that it is an epistemic fallacy to infer that “because there is no epistemologically objective view of the world, there is no objective world ontologically” (Archer et al., as cited in Wilkinson, 2013: 434). That is, it articulates that “knowing is dependent on being, but being is not dependent on knowing” (Norrie, as cited in *ibid.*). In other words, as endorsed by most critical realists (for example, Bhaskar, 1979), “holding a belief that an independent reality exists does not entail the assumption that absolute knowledge of the way that that reality works is possible (Scott, 2005: 635).

### 3. A critique of postmodernism

In addition to the points above that form the core premises of the research paradigm, critical realism, it is also worth looking briefly at a particular research perspective that has gained in significance in the recent past: postmodernism. Recognising the difficulty to categorise this –ism, which is neither a discipline nor a research paradigm, the following gives a flavour of postmodernism, though it does not tell you how deeply influential -- and controversial -- this perspective has been (Grix, 2004: 87):

1. It questions the very assumptions upon which most ‘mainstream’ research is based. They represent not just different applications of theory to research practice, but they also put many of the accepted norms and fundamentals of research in question.
2. It is an ontological position which views ‘traditional’ knowledge claims (i.e. epistemological positions) with scepticism and reflects a decline of absolutes and a readiness to accept many truths.
3. To do research in a post-modern way is to take a critical stance towards the practice of sense-making and sense-taking which we call research (Usher et al., 1997: 210-11, cited in Punch 2000a: 147-8).

Outlining the basic characteristics of postmodernism despite its very nature defying definition, I need to express that in line with my world view, I take on the first and third of these points, while seeing the second point from a different perspective. Drawing on critical realism, I simply cannot fit into some of the claims regarding reality found in either modernism or postmodernism, which developed as a reaction to the former. However, the way the latter prevailed in the 20th century can be explained through the dominance of power status over “the good” of the world which suffered from two world wars. The arguments of postmodernism that your relation to yourself is mediated by your concepts, your language, and by the society that gives you both and that “truths” are social constructions depending especially on race, class, gender and generally power status (Bonevac, 2013) can be understood; however, it is also not without limitations (*ibid.*). For example, even if our concepts of tornadoes or neutrons are social constructs, tornadoes or neutrons are not social constructs (*ibid.*). Also, it is self-refuting and hypocritical if logic is only seen as a tool of oppression because postmodernism itself can also be a tool of oppression if every discourse is a tool of oppression (*ibid.*). My main disagreement on postmodernism concerns its claim that there is no objective truth (e.g. nothing is objectively ‘right’ or ‘wrong’). Instead, I prefer to think that logic can be a tool for both liberation and oppression of selves, and that if logic or reason is just a tool for both ways, there should be a set of principles that guides logic so that it is used as a tool for liberation. Otherwise, if reason is simply a tool of oppression, then if someone and I disagree, we have nothing to talk about; we cannot use reason to settle our differences (Myerson, 1994: 58). So if reason does not work for us to settle our differences, which I agree as it has moral implications, postmodernists say there is no objective truth for us even to be right or wrong about. If we just take the side of either modernism or postmodernism, we are left with the following dichotomies: either reason/logic or social constructs; either relativism or objectivism; either positivism or interpretivism. By choosing one side over the other, we accept one part of life at the expense of the other. Metaphorically, we end up missing the forest for the trees, and this leads us to the point where, as Nietzsche saw, there is no truth but only power (Kofman, 1993: 142).



However, if both are seen as part of a large picture -- that is, if we say there is not only logic to differentiate between concepts but also social constructs in which logic cannot be sufficient to settle our differences -- then we arrive at only one conclusion: Either we understand that there must be *something* beyond logic that can guide us to use logic as a tool for both liberation of selves and oppression, or we can say that there is *nothing* for us to be right or wrong about, and this can lead to relativism, scepticism or 'a nihilistic denial of content' (Silverman, 2001: 39). In this sense, what we do is like to read our own scheme into what we experience, so what we believe -- everything about what we believe -- is about *choice*. At this point, as beings with logic, the capability to establish social constructs with our reason and power relations at the same time, we can choose to have a state of scepticism and a tendency to deny the existence of objective truth that leads us to differentiate right from wrong, or we can choose to accept the existence of an objective truth according to which we use reason- a truth that shows us the way to differentiate right from wrong and that shows us to use the reason to settle our differences- and to use it for the purpose of following good for all. Therefore, there is a moral implication as a result of this conclusion -- the possibility of knowability of right or wrong. I choose to believe that it is possible to know what is right or wrong.

Recent advances in the fields of neuroscience and psychology have also made a scientific understanding of universal human moral truth possible. These advances are in line with philosophical traditions that place more emphasis on finding commonality within humanity than stressing its differences (Harris, 2010: 1-2). Interestingly, psychological studies (Simner, 1971; Dondi et al., 1999; Hamlin et al., 2007; Colaizzi, 2016) show that newborns and infants have a sense of empathy, fairness and altruistic qualities, which reveals that morality is innately in-built in the human nature. From the social-scientific perspective, Hacking (1999: 126) puts forward the argument that everyone knows that child abuse is evil and it is a social construct shows that there is no clash between construction and reality. Holliday (2011: 135) identifies the "underlying universal cultural processes" through which humans "regardless of their background, negotiate their individuality" and highlights the oneness of humanity. My own epistemology, therefore, is one that has been informed by an understanding of the world that, while acknowledging the superficial differences in various cultures around the world, also sees the commonality of humanity. In this vein, I use the following strategies to bridge relativism and absolutism, which provide a portrait for the range of views at the same time (Garrison, 2001: 519):

**1) Reality exists apart from relativistic social construction.** Whatever is in the world exists whether people know about it or not. The Chernoble power plant existed and the pollution from its nuclear accident spread whether it was known or not known.

**2) Cultural ideas—beliefs, norms, and values—are socially constructed.** That is, people interact and definitions of what they believe to be true, moral, and valuable emerge. These constructed beliefs, norms, and values are also real and have real consequences. There is agreement that social construction occurs. Fads, styles, and hobbies, for example, all demonstrate this process. (...)

**3) This social construction of culture occurs in real life, empirical situations.** While ideas are socially constructed, they also occur in the real world as it is. For example, cultures vary as to what is defined as food but every definition must be tested by experience. Gravel will never be defined as food because the reality of trying to ingest it would be prohibitive. For a second example, architects can create buildings out of a wide variety of materials in a wide range of shapes and arrangements. But these buildings must be constructed according to the laws of physics and within the limits of the physical realities of the materials used.

**4) Relativism does not mean that "anything goes" or that anyone can do whatever one wishes.** Humans need interaction and every human relationship must be based upon some shared ideas about each person and what beliefs, values, and norms are operating in the relationship. Because these ideas are shared they cannot be significantly unilaterally changed without harming the relationship. This same process operates in larger groups and societies. There can be disagreement, but there must also be some shared definition of truth. People will disagree about

beliefs, norms, and values, but the necessity for these is evident and their existence constrains behaviour.

**5) Relativism does not mean that any one idea is as good as any other.** Continuing with the architectural analogy, some buildings “work” better than others. The floor plan of one may be more efficient for its function than another. Maintenance costs of one design may be less than another. This is also true of culture. Ruth Benedict (1934)—an early, important anthropological proponent of relativism—clearly preferred the culture of the Hopi to that of the Kwakiutil. One was a culture of harmony and the other of opposition. She valued harmony and evaluated accordingly.

Relativism does not preclude evaluation when criteria are specified.

Garrison (2001: 519) suggests that these five principles offer “a way to proceed with neither a digression to work out the question of relativism, nor a frustrating impasse in which one feels legitimately dismissive of the points presented”. While reflecting mainstream ideas about relativism, they are necessarily simple and assertive, but not simplistic (*ibid.*). In conclusion, taking seriously the “whose to say?” mentality without conceding the principles of critical realism, we can accept working principles for the absolutists while retaining a critical approach.

#### 4. Methodology Trees in Three Paradigm Farms

Imagining that various types of fruits grew up in one tree whose roots were nourished from the different elixirs of three farmers with a different theory of gardening, we could see that each farmer, according to their styles as paradigms, would make up different elixirs as methodologies, which might make use of different watering sources as methods on the way to go to the trees, and each tree would be a unique living entity with its own characteristics and own story. If the trees were nourished by the right sources, different fruits would be harvested, but if they did not accept the sources, it might not even be blossomed. Just as in this exciting process, each researcher blends his/her own elixir according to their philosophical intent or motivation for undertaking a study. Before the discussion of different gardening styles, it is appropriate to define *methodology* as ‘the overall approach to research linked to the paradigm or theoretical framework’ and the *method* as ‘systematic modes, procedures or tools used for collection and analysis of data’ (Mackenzie and Knipe, 2006: 5). The *positivistic methodology* is based on “a deductive and static cause-and-effect process with context free, isolated categories to make generalisations leading to a prediction or an accurate and reliable explanation” (Creswell, 1994: 5). An experimental, causal-comparative or correlational design is applied as its methodology is interventionist and manipulative to realise the mentioned purposes of the positivist agenda (Cohen et al., 2007).

When it comes to the methodology of the *interpretivist paradigm*, we see such hermeneutic or dialectic methodologies as phenomenology, symbolic interactionism, ethnomethodology, grounded theory and heuristic research and methods such as case studies, protocol analysis, discourse analysis, interviewing, narrative analysis, ethnography and focus groups (Denzin and Lincoln, 2005; Creswell, 2007; Flick 2006; Marshall and Rossman 1999; Maxwell, 1996; Ritchie and Lewis, 2003; Perry, 2011). The *critical paradigm*, which ‘seeks the elimination of false consciousness and facilitation of a transformed world’, implicates that its methodology such as ideology critique and action research is participative, dialogic and transformative (Phillimore & Goodson, 2004: 76). Hence, it draws on diverse range of tools describing contextual and historical factors, and both qualitative and quantitative methods can take place in a mixed way (Mertens, 2010) as long as they serve to their aim to challenge and change the situation.

#### 5. Conclusion

As discerning consumers of research, it is important to be versatile and eclectic as ready to digest whatever research method comes our way to be able to find the potential answers to research question. According to Perry’s (2011) design continua, research can be classified in one of two ends or the middle of each of three continua: Basic-Applied, Qualitative-Quantitative and Exploratory-Confirmatory. I find the continua very beneficial while analysing research studies or deciding our own research designs. As the starting point can spring from a paradigm, it may also be triggered by a problem or a question to

look for appropriate methods to find solutions or answers needed as pragmatic approach implies (Punch, 2009). In addition to being inspired by paradigms, I come to terms with Punch's (2009) call for taking both paradigm-driven and pragmatic approach into consideration and getting both to move to détente. I also find Lather's (2006: 52) suggestion fruitful in that she sees the 'aporias' or stuck places regarding 'objectivity, difference, interpretation, complexity and legitimization' as opportunities to produce different knowledge in a different way by facing the problems of the 'no longer and the not yet' history of paradigms.

## 6. References

- Bassegy, M.. (1999). *Case study research in educational settings*. Buckingham: Open University Press.
- Bhaskar, R. (1975/2008). *A realist theory of science*. London: Routledge.
- Bhaskar, R. (1979). *The possibility of naturalism: A philosophical critique of the contemporary human sciences*. Hassocks: Harvester Press.
- Bonevac, D. (2013). *Ideas of the twentieth century*. Austin: University of Texas Press.
- Cohen, L., Manion L. and Morrison, K. (2007). *Research methods in education* (6<sup>th</sup> ed.). London: Routledge.
- Colaizzi, J. M., (2016). *Empathy and prosocial behaviors in infancy (Unpublished doctoral dissertation)*. Stillwater, Oklahoma: Oklahoma State University.
- Creswell, J. W. (1994). *Research design: Qualitative and quantitative methods*. Thousands Oaks, CA: Sage.
- Creswell, J. W. (2003). *Research methods in education: Qualitative and quantitative and mixed methods approaches*. London: Sage.
- Creswell, J. W. (2007). *Qualitative inquiry & research design: Choosing among five approaches* (2nd ed.). Thousand Oaks, CA: Sage.
- Crotty, M. (1998). *The foundations of social research meaning and perspective in the research process*. London: Sage.
- Denzin, N.K. & Lincoln, Y.S. (Eds.). (2005). *The Sage handbook of qualitative research* (3<sup>rd</sup> ed.). Thousands Oaks, CA: Sage.
- Dondi, M., Simion, F., & Caltran, G. (1999). Can newborns discriminate their own cry and the cry of another newborn infant? *Developmental Psychology*, 35(2), 418-426.
- Easton, G. (2010). Critical realism in case study research. *Industrial Marketing Management*, 39, 118-128.
- Ernest, P. (1994). *An introduction to research methodology and paradigms*. RSU, School of Education, University of Exeter.
- Flick, U. (2006). *An introduction to qualitative research* (3<sup>rd</sup> ed.). London: SAGE.
- Garrison, C. E. (2001). Relativism and absolutism: Keeping college students involved in the examination of truth. *College Student Journal*, 35(4), 517-522.
- Grix, J. (2004). *The foundations of research*. London: Palgrave Macmillan.
- Hacking, I. (1999). *The social construction of what?* Cambridge, MA: Harvard University Press.
- Hamlin, J. K., Wynn, K., & Bloom, P. (2007). Social evaluation by preverbal infants. *Nature*, 450, 557-560.
- Harris S. (2010). *The moral landscape: How science can determine human values*. New York, NY: Free Press.
- Holliday, A. (2011). *Intercultural communication and ideology*. London: SAGE.
- Kofman, S. (1993). *Nietzsche and metaphor*, trans. D. Large. London: Athlone.
- Lather, P. (2006). Paradigm proliferation as a good thing to think with: Teaching research in education as a wild profusion. *International Journal of Qualitative Studies in Education*, 19(1), 35-57.
- Mackenzie, N. & Knipe, S. (2006). Research Dilemmas: Paradigms, Methods and Methodology. *Issues in Educational Research*, 16 (2) 1-11.
- Marshall, C. and Rossman, G. B. (1999). *Designing qualitative research*. Thousand Oaks: Sage.
- Maxwell, J.A. (1996). *Qualitative research design: An interactive approach*. Thousands Oaks, CA: Sage.
- Maxwell, J. A. (2012). *A realist approach for qualitative research*. London: Sage.

- Mertens, D.M. (2010). *Research and evaluation in education and psychology: Integrating diversity with quantitative, qualitative, and mixed methods* (3rd ed.). Los Angeles: Sage.
- Myerson, G. (1994). *Rhetoric, reason and society: Rationality as dialogue*. London: Sage.
- Nunan, D. (1992). *Research methods in language learning*. Cambridge: Cambridge University Press.
- Perry, Jr. F. L. (2011). *Research in Applied Linguistics: Becoming a Discerning Consumer* (2<sup>nd</sup> ed.). Routledge: Taylor & Francis Group.
- Phillimore, J. and Goodson, L. (2004). *Qualitative Research in Tourism: Ontologies, Epistemologies and Methodologies*. Routledge: Taylor & Francis Group.
- Punch, K. F. (2009). *Introduction to research methods in education*. London: Sage.
- Ritchie, J. And Lewis, J. (2003). *Qualitative research practice: A guide for social science students and researchers*. London: Sage.
- Scott, D. (2000). *Realism and educational research: New perspectives and possibilities*. London: Routledge.
- Scott, D. (2005). Critical realism and empirical research methods in education. *Journal of Philosophy of Education*, 39(4), 633-646.
- Silverman, D. (2001). *Interpreting qualitative data, methods for analyzing talk, text and interaction* (2nd ed.). London: Sage.
- Simner, M. L. (1971). Newborn's response to the cry of another infant. *Developmental Psychology*, 5(1), 136-150.
- Wilkinson, M. K. N. (2013). Introducing Islamic critical realism: A philosophy for underlabouring Contemporary Islam. *Journal of Critical Realism*, 12(4), 419-442.



# The Relationship between Ethical Leadership and Job Satisfaction

Erkan Kiral

## 1. Introduction

In the last quarter of the twentieth century, organizational leaders are expected not only to manage the organizations but also to be the executive leaders in order to contribute more to the organization. In fact, with the leadership behaviors that the administrators will exhibit the organization can easily and more effectively achieve its goals. The employees will perform the necessary activities in executive leadership willingly and voluntarily. Executive leaders will be able to use their informal powers as well as their official powers to influence employees. For this reason, leadership has been and is still the subject of many researches (Bass, 1985; Fiedler, 2006; Stogdill, 1974) within the process from the past to the present as an increasingly significant phenomenon for the organizations and for their executives. Mankind has always wondered what personality traits, behaviors and circumstances the people influencing them have had. In order to reveal them, various studies (Bass & Avolio, 1993; Bass & Steidlmeier, 1999; Nanus, 1992) have been carried out. In fact, when the latest point reached is taken into account, the exploitation-oriented production-based thought of making the most of the employees continues with the human-based, worker-centered thought but still making the most of the employees. The idea of how to make the most of the employees has never changed within the process but the techniques of achieving it have differed. The demand of making most of the employees tried to be indirectly obtained by making them feel valuable rather than putting pressure on the employees.

Not only did the enforcement of the legal foundations of the post-modern world, but also the expectations of people lead the executive leaders in administration to act in the light of universal ethical values. Executive leaders who influence the employees with universal ethical values, can of course, make better use of the potentials of the people they gather around. In this case, executive leaders can move from their current position to the ethical leader position within the contemporary leadership approaches. The universal ethical principles put forth by the ethical leader can make organizational climate be positive by positively influencing the quality of the relationships. The employees within the organization may begin to act together and exhibit the universal ethical principles that the leader himself applies to his behavior by being influenced from the ethical leader for what is good, what is bad, and what is wrong. In such an interaction-based situation, it can lead the organization to be more effective and productive. Hence, according to Yukl, the leadership process put forth by the administrator includes interaction as a phenomenon which is beyond the knowledge, skill and intelligence (2010). Ethical leader should be able to evaluate the present situation within the framework of universal ethical principles and shape his attitudes and behaviors accordingly. Together with this, ethical leadership is that; the person behaves in accordance with the norms determined within the framework of ethical principles both in his actions and in his interpersonal relationships (right, honest, justice, trust, respect, etc.); and let his followers act by communicating with them, rewarding their normative behaviors, disciplining their inadequate behaviors, and paying attention to ethical considerations in decision making (Brown, Trevino & Harrison, 2005). The basis of ethical leadership includes the intersection points of transformational, spiritual and authentic leadership, that are thinking of others, being role models and considering the events within their integrity, and the intersection point of transformational and authentic leadership, that is, making ethical decisions (Avolio & Gardner, 2005; Brown & Trevino, 2006). As mentioned, ethical leader is not just content with performing the right actions but also including those who follow him into these actions (Brown & Mitchell, 2010). In fact, the ethical leader must be able to create the ideal effect to transform the followers and be a role model for them. The fact that ethical leader has personality traits such as

honesty, principled behavior, and trustworthiness and exhibits them with his behaviors are important components leading to his effectiveness.

It is important that the behaviors of ethical leader is perceived and accepted correctly by the other side. Indeed, it is necessary that the leader should have certain characteristics to be perceived and accepted as ethical and should exhibit this with his attitudes and behaviors in the decision making process. This situation is also a valid case for all leaders, especially for such administrators of organizations as school administrators who lead for the formation of the society. As communities move towards becoming more democratic in the twenty-first century, school administrators should be able to develop their schools as places where tolerance, respect, love, justice, equality and democracy are applied at the highest level and be the pioneers for this. Exhibiting attitudes and behaviors based on such universal ethical principles as truth, honesty, justice, tolerance etc. during the school administrators' interactions with the teachers can lead the teachers to behave in the same way towards the school administrator. The better the interaction between the administrator and the employees, the more the employees exhibit ethical behaviors, the more they avoid undesired and unethical behaviors (Weaver, Trevino & Agle, 2005). School administrators may have such ethical principles as being truthful, honest, fair etc. as individuals. However, he should be able to exhibit all these universal ethical principles effectively in a unified manner as for his duty towards the internal and external stakeholders of the school. Hence, such a situation may lead him to be perceived as an ethical leader. The school administrator who has adopted and implemented ethical principles, who protects the rights of the school's stakeholders, who is honest, fair, equal, unsparing and trustworthy to them, who negotiates the decisions with the employees in such a way that it is for everyone's good, and who is visionary and open to change; has not only exhibited administrative behaviors but at the same time demonstrated effective ethical leadership behaviors in the eyes of his employees. The school administrator who acts in this way may cover a distance in not only the minds of the school's stakeholders, but also in the souls and therefore the hearts of them.

The fact that the school administrator exhibits ethical leadership behaviors can have positive consequences for both the teachers and the school. That the school administrator exhibits ethical attitudes and behaviors in an integrated manner can lead to ethical decisions, good interpersonal relationships, employee motivation, school commitment, and increased job satisfaction. These outcomes, in essence, depend on the school administrator's ethical leadership. As can be seen, the positive conclusion reached as a result of the school administrator demonstrating ethical leadership behaviors can provide the desired contribution to the effectiveness and efficiency of the school by increasing the teachers' job satisfaction. Teachers' job satisfaction can be affected by many different incidents or situations. Incidents or situations can lead to differentiations in the teachers' attitudes and feelings. Hence, according to Spector, job satisfaction is the emotional or attitudinal reaction of the employee towards his job (1985). When the employee evaluates his job, he handles it as a whole and evaluates the situation in all aspects from his colleagues to his executive, not just the work he does, and as a result of this, he gets into an emotional attitude like love or dislike. According to Kalleberg (1977), while job satisfaction is the employees' love of the job, the opposite is job dissatisfaction. According to Locke (1976), job satisfaction is the positive emotional state that occurs as a result of the employee's evaluation of the job. Teachers may have different attitudes and feelings towards the behaviors exhibited by the school administrator in the workplace. The school administrator, who is in organizational factors, may be an important element of the teachers' job satisfaction or dissatisfaction. If the managerial style of the school administrator is compatible with the teacher's personality traits and contains the universal ethical principles, it can affect the job satisfaction positively by positively influencing the motivation, success, attitude towards work, job success, and the cooperation in the school. These environmental factors, which are created within the organization, affect organizational commitment and hence job satisfaction (Locke & Whiting, 1974; Toytok, Korkmaz & Anik, 2016). Of course, this may be just the opposite. The attitudes and behaviors of the teachers within the school and those of the administrators towards the teachers are important issues that can cause the teachers to experience satisfaction or dissatisfaction in the school. Therefore, there are many studies on ethical

leadership and job satisfaction (Kim & Brymer, 2011; Yates, 2014 etc.). However, studies which investigate the relative ethical leadership and job satisfaction of the school administrators (Cetin & Ozcan, 2004; Madenoglu, Uysal, Sarier & Banoglu, 2014) are quite limited. Together with this, the fact that there has been an increase in the number of the news in the media about non-liaison appointments to schools in the recent years is another factor in conducting such a research. School administrators, who are said to have been appointed in that way, exhibit universal ethical principles in administration at what level. The ethical leadership behaviors they exhibit or do not exhibit is related to the teachers' job satisfaction at what level. The aim of this study is to reveal the relationship between the school principals' ethical leadership behaviors and the teachers' job satisfaction levels according to the perceptions of secondary school teachers. In order to achieve this aim, the answers to following questions were investigated:

- (1) According to the perceptions of secondary school teachers, what are school principals' ethical leadership behavior levels?
- (2) According to the perceptions of secondary school teachers, do school principals' ethical leadership behaviors differ according to demographic variables?
- (3) What are secondary school teachers' job satisfaction levels?
- (4) Do secondary school teachers' job satisfaction levels differ according to demographic variables?
- (5) According to the perceptions of secondary school teachers, is there a significant relationship between school principals' ethical leadership behaviors and job satisfaction levels?

## 2. Method

This research, which is descriptive relational screening model, aimed to reveal the school principals' ethical leadership behaviors levels and the teachers' job satisfactions according to the perceptions of secondary school teachers (Balci, 2009).

### 2.1. Study Group

The study group of this research was composed of 388 voluntary teachers working in the secondary schools of Efeler district in Aydin province. As a result of the analysis of data obtained in terms of the demographic features of the participant teachers, it was revealed that; 58.5% of the teachers were female (n: 227), 41.5% of them were male (n:161); 21.9% were 30 years old or below (n: 85), 23.7% were between 31-35 years old (n: 92), 23.2% were between 36-40 years old (n: 90), 31.2% were 41 years old or above (n: 121); 35.3% were working in verbal branches (n: 137), 36.6% were working in numeric branches (n: 142), 28.1% were in skills branches (n: 109); 19.1% had 5 years of seniority or less (n: 74), 23.2% had 6-10 years of seniority (n: 90), 19.6% had 11-15 years of seniority (n: 76), 14.4% had 16-20 years of seniority (n: 56), 23.7% had 21 years of seniority or more (n: 90); 94.3% were the ones who performed their professions willingly (n: 366) and 2.7% were the ones who performed their professions unwillingly (n: 22).

### 2.2. Data Collection Tool

In order to collect the data of the research, Minnesota Job Satisfaction Questionnaire (MJSQ) and Ethical Leadership Scale (ELS) were used. The features of the scales are given below.

*Minnesota Job Satisfaction Questionnaire (MJSQ)*:The questionnaire was developed by Weiss, Dawis, England & Lofquist (1967) in order to reveal the job satisfaction levels of people.The questionnaire is a 5-point Likert type scale: [I am not satisfied (1) –I am extremely satisfied (5)]. The questionnaire is composed of totally 20 items and 2 dimensions; internal satisfaction dimension is composed of 12 items, and external satisfaction dimension is composed of 8 items. In the study conducted by the researchers on different groups; the mean reliability coefficient of the groups (clerks, sellers, engineers, etc.) was found .86 for internal satisfaction, .80 for external satisfaction and .90 for overall satisfaction. The Turkish adaptation of the questionnaire was carried out by Baycan (1985) and was used in many studies (Deregozu, 2016; Basaran, 2017 etc.). Within the scope of this research, it was found that Cronbach Alpha value of internal satisfaction was .74, that of external satisfaction was .70, and that of overall satisfaction was .82.



*Ethical Leadership Scale (ELS)*:The scale was developed by Yilmaz (2005) in order to reveal the leaders' ethical behavior levels. The scale is a 5-point Likert type scale [I totally disagree (1) - I totally agree (5)]. The scale was used in many studies (Toytok, 2014; Emirbey, 2017). Construct validity and Cronbach Alpha reliability analyses were performed for the scale which was developed by Yilmaz (2005). As a result of the factor analysis performed, it was revealed that the scale was composed of totally 44 items and 4 dimensions as communicative ethics (15 items), climatic ethics (11 items), ethics in decision making (9 items), and behavioral ethics (9 items). The Cronbach Alfa reliability coefficient of the scale was found .95 for communicative ethics, .92 for climatic ethics, .94 for ethics in decision making, and .90 for behavioral ethics. The overall reliability of the scale was found .97. In this research, it was found that Cronbach Alpha values of the scale was .96 for communicative ethics, .92 for climatic ethics, .91 for ethics in decision making, .93 for behavioral ethics, and .98 for overall scale.

### 2.3.Data Analysis

In the analysis of the data obtained in the research; frequency, percentage, mean, parametric and nonparametric difference tests and correlation analysis were used. According to the perceptions of the teachers, the school principals' ethical leadership behavior levels and the teachers' job satisfaction levels were analyzed with mean and standard deviation; whether these levels differed significantly according to independent variables (gender, age, branch, occupational seniority, whether they love the profession) was analyzed with parametric difference tests (t test, ANOVA) when normality conditions were met and with non-parametric difference test (Mann-Whitney U) when normality conditions were not met. Scheffe test was performed in order to understand from which group the difference that was revealed in ANOVA test stemmed from. The measures of central tendency (mean, median and mode) were examined so as to determine whether the data met the normality conditions and it was found that they were close to each other; and also, kurtosis and skewness coefficients of the data group whose normality would be tested were examined and these values were seen to be between +1 and -1. However, because of the fact that the number of data in the variable of whether the teachers performed the profession willingly was below 30, Mann-Whitney U was used while performing an analysis with this independent variable (Can, 2016). Whether there was a significant relationship between school principals' ethical leadership behaviors and job satisfaction levels according to the perceptions of the teachers was tested with Pearson Product-Moment Correlation Coefficient as the normality conditions were met.

### 3.Findings

The findings obtained as a result of the research are given below as; the findings regarding the school principals' ethical leadership behavior levels according to the perceptions of the teachers, the findings regarding the teachers' job satisfaction levels, and the findings regarding the relationship between the school principals' ethical leadership behaviors and job satisfaction levels according to the perceptions of the teachers.

*The findings regarding the school principals' ethical leadership behavior levels according to the perceptions of the teachers*

The findings regarding the school principals' ethical leadership behavior levels are given in Table 1.

**Table 1.**Ethical Leadership Behavior Levels of Secondary School Principals

Variable	Dimensions	$\bar{X}$	Ss
Ethical Leadership	Ethics in Decision Making	4.16	.655
	Communicative Ethics	4.13	.688
	Behavioral Ethics	4.12	.687
	Climatic Ethics	4.00	.678
	General Ethics	4.10	.650

When Table 1 is analyzed, it can be seen that according to the perceptions of the teachers, the school administrators exhibited ethical behavior in decision making at the highest level, and then

## The Relationship between Ethical Leadership and Job Satisfaction

exhibited communicative, behavioral and climatic ethical behaviors, respectively. General ethical behavior level was relatively good.

No significant relationship was found both in the dimensions and overall regarding the school principals' ethical leadership behavior levels according to the teachers' gender, age, seniority, branch, and whether they perform the profession willingly ( $p > 0.05$ ).

### *The findings regarding the teachers' job satisfaction levels*

The findings regarding the teachers' job satisfaction levels are given in Table 2.

**Table 2.** Job Satisfaction Levels of Secondary School Teachers

Variable	Dimensions	$\bar{X}$	Ss
Job Satisfaction	Internal Satisfaction	4.01	.420
	External Satisfaction	3.49	.628
	General Satisfaction	3.80	.436

As can be seen in Table 2, it was found that secondary school teachers experienced internal satisfaction at most, which was followed by external satisfaction. The teachers' general job satisfaction levels were at "I am satisfied" level.

No significant relationship was found both in the dimensions and overall regarding the teachers' job satisfaction levels according to age and seniority ( $p > .05$ ). However, it was found that the teachers' job satisfaction levels showed significant differences according to the variables of gender, branch and whether they performed the profession.

While job satisfaction levels of the teachers did not differ significantly in internal job satisfaction dimension according to gender variable, it showed significant difference in external job satisfaction dimension [ $t_{(386)} = 3.535$ ;  $p < .05$ ] and overall job satisfaction [ $t_{(386)} = 2.028$ ;  $p < .05$ ]. It was found that external ( $\bar{X} = 3.63$ ;  $Ss = .60$ ) and overall ( $\bar{X} = 3.86$ ;  $Ss = .44$ ) job satisfaction levels of male teachers were higher than external ( $\bar{X} = 3.40$ ;  $Ss = .63$ ) and overall ( $\bar{X} = 3.76$ ;  $Ss = .43$ ) job satisfaction levels of female teachers.

While job satisfaction levels of the teachers did not differ significantly in internal job satisfaction dimension and in overall job satisfaction according to branch variable, it showed significant difference in external [ $F_{(2-385)} = 5.855$ ;  $p < .05$ ] job satisfaction dimension. Multiple comparative test was conducted in order to reveal which branches this difference stemmed from and it was found that external job satisfaction levels of the teachers in skill branches ( $\bar{X} = 3.64$ ;  $Ss = .614$ ) were higher than those of the teachers in numeric branches ( $\bar{X} = 3.37$ ;  $Ss = .613$ ).

While job satisfaction levels of the teachers did not differ significantly in external job satisfaction dimension according to the variable of whether they chose the profession willingly, it showed significant difference in internal [ $U = 2804.5$ ;  $p < .05$ ] job satisfaction dimension and overall [ $U = 2995$ ;  $p < .05$ ] job satisfaction. The mean ranks of the teachers who chose the profession willingly were found to be higher in internal ( $\bar{R} = 197.8$ ) and overall ( $\bar{R} = 197.3$ ) job satisfaction levels than the mean ranks of the teachers who chose the profession unwillingly in internal ( $\bar{R} = 138.9$ ) and overall ( $\bar{R} = 147.6$ ) job satisfaction levels.

### *The findings regarding the relationship between the school principals' ethical leadership behaviors and job satisfaction levels according to the perceptions of the teachers*

The Correlation test results regarding the relationship between the school principals' ethical leadership behaviors and job satisfaction levels according to the perceptions of the teachers are given in Table 3.

**Table 3.** Pearson Product-Moment Correlation Coefficient Results Regarding the Relationship between the School Principals' Ethical Leadership Behaviors and Job Satisfaction Levels According to the Perceptions of the Teachers

Variables	CE	CLE	EDM	BE	GE	IS	ES	GS
CE	1							
CLE	.861**	1						
EDM	.906**	.839**	1					
BE	.933**	.901**	.886**	1				
OE	.974**	.939**	.943**	.970**	1			
IS	.162**	.161**	.151**	.165**	.167**	1		
ES	.200**	.244**	.183**	.212**	.219**	.503**	1	
OS	.209**	.234**	.193**	.217**	.223**	.868**	.866**	1

CE: Communicative Ethics; CLE: Climatic Ethics; EDM: Ethics in Decision Making; BE: Behavioral Ethics; OE: General Ethics, IS: Internal Satisfaction; ES: External Satisfaction; GD: General Satisfaction; p value is significant at .01\*\* level.

When Table 3 is analyzed, it can be seen that there was a low level, positive, significant relationship between secondary school teachers' perceptions regarding school principals' ethical leadership behaviors and job satisfaction levels. Besides, according to the perceptions of the teachers, a high level, positive and significant relationship was found between the dimensions of school principals' ethical leadership behaviors and general ethical leadership behavior. Also, there was positive significant relationship between the teachers' internal and external satisfaction levels, and a high level, significant relationship with general job satisfaction.

#### 4. Discussion, Conclusion and Recommendations

According to the perceptions of secondary school teachers, school administrators exhibit ethical behaviors in decision making, and then communicative, behavioral and climatic ethical behaviors, respectively. Their overall ethical behavior levels are relatively high. Together with the fact that there are studies similar to this research (Emirbey, 2017; Toytok & Kapusuzoglu, 2016), there are also studies with different conclusions (Guler, 2017; Helvaci, 2010). As a matter of fact, while Guler (2017) and Kalaz (2016) revealed that school administrators exhibited behavioral ethics at the highest level; Buyukgokce (2015) expressed that school administrators exhibited communicative ethics at the highest level; Helvaci (2010) found that school administrators exhibited behavioral ethics at the lowest level; and Kalaz (2016) found that school administrators exhibited ethics in decision making at the lowest level. According to the results of this study, it can be said that school principals care about the ethical values in the school and transform them into behaviors, and that the teachers accept school administrators as the leaders attached to principles. The school principal is one of the important elements of the climate in the school. The fact that the climate of the school is good or bad can show itself with the practices of the school principal. Indeed, in a school, a principal may be the most important determinant and practitioner of ethical behaviors. According to Yilmaz (2006), the school administrator has to have ethical leadership skills and exhibit them. School administration requires individual ethical superiority. For this, the school administrator must lead to his employees through ethical leadership skills and personal ethical leadership behaviors. When the ethical leader makes decisions, he tries to make an ethical decision rather than making an ordinary decision, takes the consequences into account thoroughly and includes the employees into the ethical decision-making process when necessary (Kiral, 2015). One of the essential ethical skills that school administrators should have is to include teachers in the decision-making process (Shapiro & Stefkovich, 2010). Therefore, the school administrator gives responsibilities to teachers by exhibiting ethical leadership behaviors (Wahlstrom & Louis, 2008), makes the decisions that may be problematic in the outcomes and thus, becomes an example to teachers by doing the right job (Bennis, 1995, Stefkovich, 2013). The fact that school principals possess ethical behaviors and exhibit them by including the employees in the decision making process in practice, communicating with them and establishing a positive climate within school are important

components that increase the effectiveness of the school. The teachers who are influenced by the ethical behaviors of the school principal may feel better and perform better in order to achieve the school's goals and objectives.

There was no significant difference between school principals' ethical leadership behaviors according to the teachers' gender, age, seniority, branch, and whether they chose the profession willingly variables. It can be said that the independent variables mentioned do not make any difference in the ethical leadership behaviors of the school administrators. Similar results were obtained in the study of Erdogan (2016). However, in the study of Emirbey (2017), it was found that female teachers, rather than men, thought school administrators exhibited a higher level of ethical leadership behaviors. In the studies of Kalaz (2016), it was revealed that older teachers perceived that the school administrators exhibited higher levels of ethical leadership behaviors rather than younger teachers. In the study of Celik (2013), vocational lesson teachers perceived school administrators' behaviors in the communicative ethics, climatic ethics and ethics in decision-making dimensions at a higher level than culture lesson teachers. Tombak (2012) found in his study that the perceptions of class teachers regarding school administrators' ethical leadership behavior levels were higher than those of branch teachers. According to these results, the perceptions of teachers' regarding school administrators' ethical leadership behaviors may differ according to independent variables.

It was found that job satisfaction levels of secondary school teachers were high in overall satisfaction and in the dimensions of satisfaction. It was determined that they exhibited internal job satisfaction the most, which was followed by external job satisfaction. Similar results were obtained in the studies conducted by Ozkan (2017) and Basaran (2017). The fact that internal job satisfaction is high can be an important indicator of that the teachers perform their profession willingly. The relatively low level of external satisfaction may be a sign of the problems in the working environment, unsatisfactory pay, experiencing difficulties in promotion, and the inadequacy and unreliability of rewarding and promotion systems.

There was no significant difference in the teachers' job satisfaction levels according to age and seniority. Similar conclusions were obtained in the studies of Ozkan (2017), Basaran (2017), Yilmaz & Kiral (2014), Diri & Kiral (2016) and Nagar (2012). However, in the research of Darmody & Smyth (2011); while it was revealed that younger teachers had higher job satisfactions than older ones, in the study of Sargent & Hannum (2005), this was just the opposite. In Erdogan's (2017) study, it was found that as the age of the teachers increased, their job satisfaction increased, too. In the studies of Darmody & Smyth (2011) and Gupta & Gehlawat (2013), it was found that job satisfaction levels of junior teachers were higher than those of senior teachers. It can be said that job satisfaction levels of the teachers decrease in time as their individual expectations in the first years of the profession cannot be met as they progress in the profession.

It was found according to gender variable that external and overall job satisfaction levels of male teachers were higher than female teachers. Similar results were obtained in the studies of Ozkan (2017) and Basaran (2017). However, it was determined in the studies of Erdogan (2017), Akyurek (2016), Raj & Lalita (2013) and Sargent & Hannum (2005) that the gender of the teachers did not make a significant difference in their job satisfaction. The fact that external satisfaction levels of male teachers were higher in this study may be caused by such factors as promotion opportunities, the additional tuition fee earned by working overtime, the possibility of being able to participate more to long term professional development courses rather than female teachers, and etc. Moreover, while the role of women within the family may show up as a relatively more important factor than their jobs, this situation can vary for men and most of the time their jobs are more important. In the study of Ololube (2006) it was found that job satisfaction levels of female teachers were significantly higher than male teachers. The reason why it is different in the present study may be the fact that women have got to struggle more to achieve the positions they are in within the organizations, and that they are more satisfied internally with the success they have achieved at the end of the struggle.

It was found that external satisfaction levels of the teachers in the skill lessons branch were higher than those of the teachers in the numeric branch. Similarly, it was determined in the researches of Yilmaz & Kiral (2014) that the branches of teachers made differences in their job satisfaction levels.

However, it was found in the studies of Ozkan (2017), Erdogan (2017) that the branches of the teachers did not make any difference in their job satisfaction levels. In this research, external job satisfaction levels of the teachers may be low as the responsibilities of the teachers in the numeric branches are a lot because of the fact that they prepare the students for the national tests, the expectations of the families of these students are high and thus, the teachers feel pressure.

It was found that the teachers who chose the teaching profession willingly had higher levels of internal and overall satisfaction levels than the teachers who did not chose the profession willingly. Similar results were obtained in the studies of Yilmaz & Kiral (2014), Diri & Kiral (2016). However, in the studies of Deregozu (2016) and Turkcapar (2012), there was no significant relationship between the teachers' job satisfaction levels and whether chose their profession willingly. The fact that the teachers who chose the teaching profession voluntarily and who are willing to do their jobs are have positive attitudes towards other teachers and school, that they make the job enjoyable and have fun doing it, and that they are open to professional development may have caused their satisfaction to be high. Hence, a person who does not choose his job willingly will, therefore, perform unwillingly, develop negative attitudes towards work and even not want to be within the work environment. Those who do not love their profession may not even want to create a friendship atmosphere at school and may have driven themselves to loneliness. According to Yilmaz (2006), teaching is a profession where relations are based on love and trust. People who choose their professions willingly do their jobs affectionately and thus, satisfied with it. It can be said that doing the job willingly is an important factor that increases satisfaction.

It was found that there was a low level, positive, significant relationship between the teachers' perceptions regarding school principals' ethical leadership behaviors and job satisfaction levels. Similar results were obtained in the studies of Olcum & Ozcan (2004), Madenoglu, et al. (2014) and Basaran (2017). It was also revealed that there were high level, positive, significant relationships among the teachers' perceptions regarding school principals' ethical leadership behaviors. Similar results were found in the study of Mertler (2015). It was found that there was a positive, moderate level relationship between the teachers' internal and external job satisfaction levels; and a high level, significant relationship with overall job satisfaction. Similar results were obtained in the study of Basaran (2017). According to these results, it can be said that ethical leadership behaviors of the school principals are in relationship, though low, with the teachers' job satisfaction. According to Simsek, Akgemci and Celik (2011), the leadership styles of the administrators influence the employees' job satisfaction. Hence, the decisions that employees perceive as fair can influence employees' satisfaction and performance by increasing the trust in the administrator (Yukl, 2010). The positive effects of school administrators' ethical leadership behaviors on teachers' motivation can relatively increase teachers' job satisfaction up to the desired level (Yilmaz & Kiral, 2014; Emirbey, 2017). By indigenizing universal ethical principles such as justice, equality, respect, tolerance, faithfulness, honesty and responsibility, school administrators should exhibit these with their behaviors at any moment (Stefkovich & Begley, 2007; Aydin, 2001; Buyukgokce, 2015, Kiral, 2017). By demonstrating ethical principals in their behaviors, school administrators can positively affect the employees in the school. In addition, the fact that employees feel themselves safe, comfortable and happy while doing their jobs can increase their job satisfaction. If inappropriate and non-ethical behaviors are exhibited, employees may become dissatisfied.

School administrators' ethical leadership behaviors can positively affect friendship relationships, teachers' development opportunities, participation in the decisions, and self-expression in the school environment. Taking the behaviors exhibited by school administrators as a model by the stakeholders of the school can lead them to exhibit similar behaviors. According to Madenoglu, et al. (2014), school administrators' ethical leadership behaviors make a positive contribution to teachers' job satisfaction. In their study, Brown et al. (2005) found that the administrators' ethical leadership behaviors perceived by employees positively affect their job satisfaction, job commitment and solving their job-related problems. School administrators' ethical leadership behaviors can lead the teachers to become more effective and efficient employees for their schools. According to Akyurek, it can be said that as the level

of leadership functions of school administrators increases, teachers' job satisfaction increases, too (2016).

As a result, according to the findings obtained; with the participation of all stakeholders, ethical principles can be created for the school by taking into account universal and national values. In order to increase the external satisfaction of teachers, reward and promotion systems can be revised according to objective criteria. Promotion opportunities for female teachers can be presented bearing in mind their circumstances (being a mother, family expectations, housework, etc.). What should be done to increase the external satisfaction levels of numeric lesson teachers and the reasons why teachers who did not choose such a sacred profession as teaching willingly but still continue to do can be revealed with a qualitative research. The qualifications this profession requires and the risks involved in it can be informed to people who will choose the teaching profession. Ethical committees may be established within the school where school stakeholders are also involved so that school administrators can improve their existing ethical leadership behaviors.

## 5. References

- Akyurek, M. I. (2016). *İlkokul mudurlerinin dagitilmis liderlik ozellikleri ile ogretmenlerin is doyumunu algilari arasindaki iliski: Ankara ili ornegi [The relationship between the distributed leadership characteristics of primary school principals and the teacher's perception of jobsatisfaction: Sample from Ankara]*. (Yayınlanmamış Yüksek Lisans Tezi). Gazi University, Turkey.
- Avolio, B. J., & Gardner, W. L. (2005). Authentic leadership development: Getting to the root of positive forms of leadership. *Leadership Quarterly*, 16 (3), 315-338.
- Aydin, I. P. (2002). *Yonetsel, mesleki ve orgutsel etik. [Managerial, professional and organizational ethics]*, Ankara: PegemA Yayıncılık.
- Balci, A. (2009). *Sosyal bilimlerde araştırma: Yöntem, teknik ve ilkeler [Research concepts, techniques and methods in social sciences]*, Ankara: Pegem Akademi.
- Bass, B. M. & Avolio, B. J. (1994). *Improving organizational effectiveness through transformational leadership*. Thousand Oaks, CA: Sage.
- Bass, B. M. & Steidlmeier, P. (1999). Ethics, character, and authentic transformational leadership behavior. *Leadership Quarterly*, 10 (2), 181-217.
- Bass, B. M. (1985). *Leadership and performance beyond expectations*. New York: Free Press.
- Basaran, M. (2017). *Okul yoneticilerinin yonetim bicimleri ile ogretmenlerin is doyumunu arasindaki iliskinin incelenmesi [Analysing the relationship between the management styles of schoolprinciples and job satisfaction of teachers]*. (Unpublished master thesis). Gazi University, Turkey.
- Baycan, F.A. (1985). *Farkli gruplarda calisan kisilerde is doyumunun bazi yonlerinin analizi.[Analysis of several aspects of job satisfaction between different occupational groups]*. (Unpublished master thesis). Bogazici University, Turkey.
- Bedir, G. (2017). *Ozel okullardaki yoneticilerin etik liderlik davranislarinin kurum ogretmenlerinin motivasyon duzeyi ile iliskisi [The relationship between ethical leadership behaviors of private school administrators and motivation levels of teachers]*. (Unpublished master thesis). Istanbul Sabahattin Zaim University, Turkey.
- Bennis, W. (1995). Leadership theory and administrative behavior: the problem of authority. *Administrative Science Quarterly*, 4, 259-260.
- Buyukgokce, A. (2015). *Okul mudurlerinin etik liderlik davranislarinin incelenmesi: Bir karma yontem arastirmasi, [Examination of ethical leadership behaviors of school principals: A mixed method research]*. (Unpublished master thesis). Mevlana University, Turkey.
- Brown, M. E., Treviño, L. K., & Harrison, D. A. (2005). Ethical leadership: A social learning perspective for construct development and testing. *Organizational Behavior and Human Decision Processes*, 97(2), 117-134.
- Brown, M. E., & Treviño, L. K. (2006). Ethical leadership: A review and future directions. *Leadership Quarterly*, 17 (6), 595-616.
- Brown, M. E. & Mitchell, M. S. (2010). Ethical and unethical leadership: exploring new avenue for future research. *Business Ethics Quarterly*, 20 (4), 583-616.

- Can, A. (2016). *SPSS ile bilimsel arastirma surecinde veri analizi. [Data analysis in the scientific research process with SPSS]*. Ankara: PegemA Akademi.
- Celik, N. (2013). *Ortaogretim kurumlari yoneticilerinin etik liderlik anlayislari ile orgut calisanlarinin orgutsel bagliliklari arasindaki iliski (Bursa ornegi).[The relationship between ethical leadership perception of the leaders of the secondary education institutions and institutional commitment of the institution employees].(Bursa Case)*. (Unpublished master thesis). Okan University, Turkey.
- Cetin, M., & Ozcan, K. (2004). Okul yoneticilerinin etik davranislarinin ogretmenlerin is doyumuna etkisi [The ethical behavior of school administrators is the effect of teachers' job satisfaction]. *Marmara Universitesi Atatürk Egitim Fakultesi Egitim Bilimleri Dergisi [Marmara University Faculty of Education Journal]*, 20 (20), 21–38.
- Darmody, M. & Smyth, E. (2011). Job satisfaction and occupational stress among primary school teachers and school principals in Ireland. *ESRI/ The Teaching Council: Dublin, Ireland*.
- Deregozu, A. (2016). *Kamu ve ozel sektörde calisan ogretmenlerin is doyumunu ve benlik saygisinin incelenmesi [Public and private sector employees of investigation of teacher job satisfaction and self-esteem]*, (Unpublished master thesis). Beykent University, Turkey.
- Diri, M. S., & Kiral, E. (2016). Ortaokul ogretmenlerinin is doyumlarının mesleki tukenmislik duzeylerine etkisi. [The effect to secondary school teachers' job satisfaction to the occupational burnout level]. *Mehmet Akif Ersoy Universitesi Egitim Fakultesi Dergisi, [Mehmet Akif Ersoy University Faculty of Education Journal]*, 3(39), 125-149.
- Erdogan, H. (2016). *Ilkogretim kurumlarinda gorev yapan okul mudurlerinin etik liderlik davranislarinin ogretmenlerin gorusleri acisindan degerlendirilmesi [The evaluation of ethical leadership behaviours of the school principals working at the primary education institutions with regards to teachers' views]*. (Unpublished master thesis). Yuzuncu Yil University, Turkey.
- Emirbey, A. R. (2017). *Okul yoneticilerinin etik liderlik davranislari ile ogretmen motivasyonu arasindaki iliski [The relationship between ethical leadership behaviours of school administrators with motivation of teacher]*. (Unpublished master thesis). Usak University, Turkey.
- Fiedler, F. E. (1964). A contingency model of leadership effectiveness. In L. Berkowitz (Ed.), *Advances in experimental social psychology*, (pp.149-190). New York: Academic Press.
- Gupta, M. & Gehlawat, M. (2013), Job satisfaction and work motivation of secondary school teachers in relation to some demographic variables: A Comparative study, *Educationia Confab*, 2 (1), 10-19.
- Guler, T. (2017). *Ortaokul mudurlerinin etik liderlik davranislari ile ogretmenlerin orgutsel sessizlikleri arasindaki iliski [The relationship between ethical leadership behaviours of secondary school managers with organizational silences of teachers]*. (Unpublished master thesis). Usak University, Turkey.
- Helvaci, M. A. (2010). Ilkogretim okulu yoneticilerinin etik liderlik davranisi gosterme duzeyleri. [The level of primary school administrators showing ethical leadership behavior]. *Journal of World of Turks*, 2(1), 391-410.
- Kalaz, M. (2016). *Ogretmen goruslerine gore okul yoneticilerinin etik liderlik ozellikleri ile ogretmenlerin orgutsel adanmisliklari arasindaki iliskinin incelenmesi [Examination of the relationship between school principals' ethical leadership characteristics and teachers' organizational commitment according to teachers' opinions]*. (Unpublished master thesis). Yildiz Teknik University, Turkey.
- Kalleberg, A. L. (1977). Work values and job rewards: A theory of job satisfaction, *American Sociological Review*, 42(1), 124-143.
- Kiral, E. (2017). *Ulusal ve evrensel degerlere iliskin ogrenci gorusleri [Student views on national and universal values]*. Paper presented at the 12 th International Conference on educational Administration, Ankara.
- Kiral, E. (2015). Yonetimde karar ve etik karar verme sorunsali [Decision in Management and Ethical Decision Making Problematique]. *Adnan Menderes Universitesi Egitim Fakultesi Egitim Bilimleri Dergisi [Adnan Menderes University Faculty of Education Journal]*, 6(2), 73-89.
- Kim, W. G., & Brymer, R. A. (2011). The effects of ethical leadership on manager job satisfaction, commitment, behavioral outcomes, and firm performance. *International Journal of Hospitality Management*, 30 (4), 1020-1026.

- Locke, E. A. (1976). The nature and causes of job satisfaction. In M. D. Dunnette (Ed.), *Handbook of industrial and organizational psychology*. Chicago: Rand McNally.
- Locke, E. A., & Whiting, R. J. (1974). Sources of satisfaction and dissatisfaction among solid waste management employees. *Journal of Applied Psychology*, 59, 145-156.
- Madenoglu, C., Uysal, S., Sarier, Y., & Banoglu, K. (2014). Okul mudurlerinin etik liderlik davranislari ile ogretmenlerin is doyumlarının orgutsel baglilikla iliskisi [The relationship between ethical leadership behaviors of school principals and teachers' job satisfaction with organizational commitment]. *Kuram ve Uygulamada Egitim Yonetimi Dergisi [Educational Administration: Theory and Practice]*, 20 (1), 47-69.
- Mertler, B. Z. (2015) *Sinif ogretmenlerinin okul yoneticilerinin etik liderlik davranislarina iliskin gorusleri [Primary school teachers' opinions on concerning ethical leadership behavior of school administrators]*. (Unpublished master thesis). Okan University, Turkey.
- Nagar, K. (2012). Organizational commitment and job satisfaction among teachers during times of burnout. *VIKALPA*. 37 (2), 43-60.
- Nanus, B. (1992), *Visionary leadership: Creating a compelling sense of direction for your organization*, San Francisco: Jossey-Bass Inc.
- Ololube, N. P. (2006). Teachers job satisfaction and motivation for school effectiveness: an assessment. Retrieved from <https://eric.ed.gov/?id=ED496539>
- Ozkan, A. (2017). *Ilkokul ve ortaokul ogretmenlerinin is doyumunu duzeyleri (Balikesir ili merkez ilceler ornegi) [Job satisfaction levels of the primary schools teachers and the secondary schools teachers (Balikesir central district sample)]*. (Unpublished master thesis). Balikesir University, Turkey.
- Polatkan, N. N., & Kiral, E. (2017). *Ortaokul ogretmenlerinin duygusal emek davranislari ile is doyumlari arasindaki iliski [The relationship between the secondary school teachers' emotional labor and their job satisfaction]*. Paper presented at the IV<sup>th</sup> International Eurasian Educational Research Congress, Pamukkale.
- Raj, T. & Lalita. (2013). Job satisfaction among teachers of private and government school: a comparative analysis. *International Journal of Social Science & Interdisciplinary Research (IJSSIR)*. 2 (9), 151-158.
- Sargent, T. & Hannum, E. (2005), Keeping teachers happy: job satisfaction among primary school teachers in rural north west china, *Gansu Survey of Children and Families Papers*, 174-204.
- Shapiro, J. P. & Stefkovich, J.A. (2010), *Ethical leadership and decision making in education: applying theoretical perspectives to complex dilemmas* (4th ed.), New York: Taylor & Francis Inc.
- Spector P.E.(1985). Measurement of human service staff satisfaction: Development of the Job Satisfaction Survey. *American Journal of Community Psychol*, 13 (6), 693-713.
- Stefkovich, J.A. (2013). *Best interests of the student: Applying ethical constructs to legal cases in education* (2nd ed.). New Jersey: Lawrence Erlbaum Associates.
- Stefkovich, J. A. & Begley, P. T. (2007). Conceptualizing ethical school leadership and defining the best interests of students, *Journal of Educational Management Administration and Leadership*, 32 (2), 205-225.
- Stogdill, R. M. (1974). *Handbook of leadership: A survey of theory and research*. New York: Free Press.
- Simsek, S., Akgemci, T. & Celik, A. (2011) *Davranis bilimlerine giris ve orgutlerde davranis [Introduction to behavioral sciences and behavior in organizations]*, Gazi Kitabevi: Ankara.
- Tombak, N. (2012). *Ilkogretim okulu yoneticilerinin etik liderlik davranisi gosterme duzeylerinin incelenmesi: Mugla ili ornegi [Examining the levels of ethical leader ship behaviours of the primary school adminisrators: the sample of Mugla provience]*. (Unpublished master thesis). Dokuz Eylul University, Turkey.
- Toytok, E. H., & Kapusuzoglu, S. (2015). Influence of school managers' ethical leadership behaviors on organizational culture: Teachers' perceptions. *Eurasian Journal of Educational Research*, 66, (1), 373-388.
- Toytok, E. H. (2014). *Ogretmen algilarina gore okul yoneticilerinin etik liderlik davranislarinin orgut kulturu uzerine etkisi: Duzce ili ornegi [The effects of ethical leadership behaviors of school administrators*



- organisation culture according to teachers' perceptions: Sample of Duzce city*. (Unpublished doctoral dissertation). Abant Izzet Baysal Eylul University, Turkey
- Toytok, E. H., Korkmaz, M., & Anik, S. (2016). Environmental conditions of the city in which teachers serve and their organizational commitment perception levels. *The Anthropologist*, 24 (1), 90-96.
- Turkcapar, U. (2012), Beden egitimi ogretmenlerinin farkli degiskenler acisindan is doyumunu duzeylerinin incelenmesi [Study of job satisfaction level according to different variant among physical education teachers]. *Gazi Egitim Fakultesi Dergisi*. [Journal of Gazi Education Faculty], 32, (2), 331-346.
- Wahlstrom, K. L., & Louis, K. S. (2008). How teachers experience principal leadership: the roles of professional community, trust, efficacy, and shared responsibility. *Educational Administration Quarterly*, 44, 458-495.
- Weaver, G. R., Treviño, L. K., & Agle, B. (2005). Somebody I lookupto: Ethical role models in organizations. *Organizational Dynamics*, 34(4), 313-330.
- Weiss, D. J., Davis, R. V., England, G. W., & Lofquist, L. H. (1967). *Manual for the Minnesota Satisfaction Questionnaire*. Minneapolis: University of Minnesota.
- Yates, L. A. (2014). Exploring the relationship of ethical leadership with job satisfaction, organizational commitment, and organizational citizenship behavior, *The Journal of Values-Based Leadership*, 7(1).  
Redrived from <https://scholar.valpo.edu/jvbl/vol7/iss1/4>
- Yildiz, H. (2016). *Spor yoneticilerinin etik davranislari* [Ethic behaviours of sports administrators]. (Unpublished master thesis). Selcuk University, Turkey.
- Yilmaz, E. (2006). *Okullardaki orgutsel guven duzeyinin okul yoneticilerinin etik liderlik ozellikleri ve bazi degiskenler acisindan incelenmesi*. [To Investigate the effect of school managers' ethical leadership levels on the organizational trust level and to test whether the organizational trust level in schools differentiate with respect to some variables or not]. (Unpublished doctoral dissertation). Selcuk University, Turkey.
- Yilmaz, E. (2005). *Etik liderlik olceginin gecerlilik ve guvenirlilik calismasi*. [Validity and reliability study of ethical leadership scale]. Paper presented at the 14 th National Conference on educational administration, Denizli.
- Yilmaz, M. & Kiral, E. (2014). The relationship between motivation and job satisfaction of secondary school teachers, *International journal of psycho-educational sciences*, 3 (3), 74 -90.
- Yukl, G. A. (2010). *Leadership in organizations* (7th ed.). Upper Saddle River, NJ: PrenticeHall.

# Evaluation of Effectiveness of Vitamin Teacher Portal

Hasan Arslan, Osman Ferda Beytekin, Meltem Kuscu

## Introduction

Learning portals are an e-learning environment used in National Education, private sector and the universities. The purpose of using portal in education is to facilitate accessing information and to provide service better. Portals are used in many other education areas such as private organizations, coaching companies, and language learning centers etc. The portal which is known most commonly in our country is the "turkiye.gov.tr" website. This website is expressed as the gate to the state.

The lexical meaning of the Portal concept, which has been started to be used frequently since 1995, is expressed as follows in various dictionaries; Redhouse: gateway, large or imposing door or entrance; Oxford English Dictionary: a large and imposing door, gateway, doorway or passageway; Whatis.Com: gateway, websites visited to access other websites; Webopedia: is a Website offering various services such as very large sources and e-mail, forums, search engines and online shops etc. (pbs.com, 2015). According to another definition, the "Web Portal" can be defined as a "Super website" which functions as an access point to numerous sources and services through the Internet (workcube.com, 2017).

The first Web portals, such as Yahoo, AOL etc., were the websites providing services through the Web. By the time, in order to reach larger masses, many websites, notably the search engines, have accommodated themselves with the Portal characteristics, and the concept has broadened accordingly. The advantages of Portal can be listed as follows; availability to reach the relevant information, time savings for the end user, making decisions better and faster, effective communication with the employees, providing more effective cooperation, possibility for the users to access information that the users are unaware of their existence, creating and sustaining competitive advantage, effective communication with the suppliers and business partners, and decreasing the affairs that have been neglected in terms of information technology (portal.com, 2016 ).

The portal types can be classified in terms of scope, according to their target audience, according to the sectors, according to their purposes, and according to their subjects. Characteristics of a portal can be listed as; integration, customization, personalization, categorization, searching, content management, work flow, single login, and security (portal.com, 2016).

## Importance of Learning Portals in Education

Learning portals are an e-learning environment used in National Education, private sector and the universities. The purpose of using portal in education is to facilitate accessing information and to provide service better. Portals are used in many other education areas such as private organizations, coaching companies, and language learning centers etc. The portal which is known most commonly in our country is the "turkiye.gov.tr" website. This website is expressed as the gate to the state.

The portals used in the National Education are "www.egitim.gov.tr", "www.vitaminogretmen.com" and "www.vitaminegitim.com" websites. It is aimed to promote use of technology in education and to improve the quality of education with the use of these websites. The students and the teachers can access information on the same platform. These portals providing e-learning ensures that individual diversities are taken into consideration and every student is able to access information and study either at school or home depending on his/her speed. Thus, it is aimed to develop self confidence in the students as well. Moreover, with these portals, parents have the chance to follow their students more closely.

### **Problems in Use of the Learning Portals**

If it is necessary to list the obstacles to use widely the information technologies in education in Turkey; we can list the facts that the shareholders are not included adequately in the decision processes, the poor-quality of in-service trainings (in terms of suitable pedagogy and technological integration), quality and quantity problems of e-materials, syllabus strictness (syllabus does not provide adequate clear opportunities to the teacher autonomy), BOTE (Computer and Instructional Technologies Training) graduates does not have sufficient opportunity, managers' and teachers' concerns/attitudes/self-efficacy perceptions, lessons regarding information technology are not included adequately in the schools, and it is considered that the technology literacy consists of only writing with MS Word and following our friends in Facebook (Sezer, 2014).

The most important problem of the learning portals is not having the adequate knowledge level. Since the portals are not promoted well enough, teacher, student and parents are not aware of this website. And even if they are aware of it, they refrain from using it because they are not familiar with its content. Another point is that to what extent the webmasters of the websites are involved in education is disputable. When designing an education system, opinions of the individuals involved in education should be taken.

Another important problem is poverty and living conditions. From the viewpoint of students, while there are children without electricity and running water in their homes, how it can be possible to make discussions about e-learning is yet another matter of debate. A considerable number of children do not have an Internet connection in their homes. And this is one of the obstacles to e-learning.

### **The Purpose of the Vitamin Ogretmen Portal**

The Vitamin Ogretmen Portal was put into practice by private company named Sebit. It is the Vitamin Ogretmen portal itself that tells us what it is and what its purpose is. In the "vitaminogretmen.com" website, its purpose is explained as follows: *"Learning, assimilating the knowledge, is pleasing for everyone. When you follow the right way, and discover the right methods....And it is reassuring to feel that you are not alone, your efforts are valued among your colleagues who share the common purpose with you. Just as the strength that nearly 250 thousand teachers who come together in the professional development and sharing portal, the Vitamin Ogretmen, take from each other, as a company that has ensured a significant progress in use of technology in education, we have known from the beginning that effective use can be possible only through correct and conscious application, and that the most important factor in this process is "teacher". Teacher should have been supported continuously and intensely for compliance with both the technology and the innovations brought by the new education paradigm. And we set off... In 2009, in order to ensure that the computer aided education is used in the in-class processes, we have held more than 100 meetings in 81 provinces and reached 24 thousand teachers. Then, witnessing closely the value added to the teachers by the inter-teacher communication and sharing during the in-service training that we gave to around 700 teachers with our Teacher Professional Development Training (OMGEP) program, by our nature, we decided to develop a portal in order to offer such an environment to them as an online service and to make that close contact sustainable. Thus, the Vitamin Ogretmen commenced its broadcasting life as a product of such an intense inspiration on a meaningful day, November 24, 2009. The purpose of the Vitamin Ogretmen is simply to add value to the lives of our teachers, ..... all the enlightened teachers who feel responsibility in raising the quality standards in Education, who believe that they are in the center of transformation, who continuously renew themselves, who are interested in modern and experimental education methods, and who appreciate sharing..."*

### **Content of the Vitamin Ogretmen Portal**

A renovation process was carried out in all websites of the National Education in December 2014. For example, while the websites of the National education used to be accessible by means of the Internet Explorer, now they are accessible through any browser. This has been a useful renovation for facilitation of works and transactions. And the Vitamin Ogretmen website also took advantage of this situation as well. As of December 2014, the website has attained its new design.

When we look at the new content, we see that the Subjects are collected under three headings. It consists of educational sharings, professional development and content archive tabs. Furthermore, there are buttons that facilitate searching documents according to any levels and any branches. There are documents and discussions under the educational sharing. Documents can be uploaded or downloaded according to the available topics under the documents heading. Under the discussions option, besides being able to type comments for and participate in the available subjects, teachers can also create new topics and discussions. Under the professional development tab, there are certain topics such as the subject assessment and evaluation, classroom management, educational world of 21st Century etc. And various videos, documents and discussions with respect to the topic can be accessed under these headings. In the content archive, there are important and useful documents such as educational videos, live videos, educational scripts, and annual plans etc. Entrance by the government teachers and entrance by the private school teachers are designed separately. State school teachers log in using the MEBBIS (Ministry of National Education Information Systems). Private school entrance can be used by private school teachers as well as by the teacher candidates and the academicians. The Vitamin Ogretmen website which has a substantially rich content allocates a significant space to main courses and technology, while it gives slightly lesser space to the art courses. The fact that certain courses such as the music, visual arts, physical training etc. have lesser contents provides the most important evidence of our examination-based education system.

Another sharing in the website is that good examples are included in the education. Such sharings give add meaning to the website, create awareness in other teachers, and set them an example. By means of involving extracurricular educational videos, it fulfills the duty of guiding those teachers that want to improve themselves. By virtue of the Vitamin Ogretmen portal which has interaction with the Vitamin Education website, the teachers can create a class with the students who are subscribed to the Vitamin Education, prepare examinations, and give homework. It is a highly useful application in this respect as well.

### **Problems in Use of the Vitamin Ogretmen Portal**

The Vitamin Ogretmen website has not yet reached the desired number of users. It should reach more teachers throughout the country. For this reason, it is essential to ensure that each teacher uses the Vitamin Ogretmen website at least once. This is the sole way for creating awareness in the teachers. It is thought that the teachers who see the richness of the website would strive to make the website even more enriched.

On the other hand, the fact that our teachers who try to practice their profession under challenging conditions have difficulties in finding adequate time for improving themselves appears as another problem. It seems a little bit difficult for our teachers who serve as a deputy headmaster alone at their school to enter in any websites where they could provide individual and professional improvement. There are teachers who cannot allocate some time to educational portals on account of dealing with the paperwork of the school and education of the students. In addition to that, the fact that there are teachers who are not enthusiastic about improving themselves is, besides being discouraging, a factor for the low number of users of such websites. However, the updates for the uses in the website have a hitch from time to time. When a teacher who has appointed to another duty enters into the website, sometimes the name of the former school might be displayed. For this reason, user updates should be followed-up more frequently.

### **Method**

The question of the study is; Is the Vitamin Ogretmen Portal an application which is satisfying in its field and which has achieved its goal in the teachers' opinion? Is it useful for training and education environment by creating awareness in the teachers? In this study, semi-structured interview method was used to investigate these questions.

Interview is one of the data collection techniques most commonly used in the qualitative researches. It is more effective in making use of experiences and opinions of individuals. On account

that the persons participating in the interview state their opinions verbally, they have the opportunity to express themselves more comfortably. (Yildirim and Simsek, 2011).

Interview is a data collection technique by means of verbal communication. Though interviews are mostly conducted face to face, it can also be conducted by means of instant audio and video transmitters such as telephone or video-phone systems. Furthermore, sign language communication with deaf and dumb is also included in the interview classification (Karasar, 2012).

The reason for using the qualitative research method in this study is to obtain in-depth information about the subject. In order to examine the effectiveness of the Vitamin Ogretmen Portal, the opinions of teachers were resorted to. The most suitable way to examine the Vitamin Ogretmen Portal's effectiveness and its reflection to the classroom environment from the viewpoint of teachers is application of the interview technique. For this reason, the interview technique, which is one of the qualitative research methods, was used as the data collection means to obtain quality data with open-ended questions. 10 questions were asked during the interviews. It was assumed that the participants gave sincere answers to the questions.

### Findings

The interview forms within the scope of the study were assessed separately based on the questions. 10 persons participated in the research. The statistical information regarding sex, seniority and age of the participants can be seen in the following Table 1.

**Table1-Participant Information**

Participants	Gender	Age	Seniority
P1	F	52	29
P2	F	29	8
P3	M	28	6
P4	M	30	8
P5	F	34	12
P6	M	30	7
P7	M	32	9
P8	F	31	7
P9	F	49	28
P10	F	36	13

10 questions are asked in the interview form prepared to investigate the effectiveness of the Vitamin Ogretmen Portal for teachers. The questions were prepared by the author. The answers given were evaluated within the scope of the content analysis. The results for each question are as follows.

Question: When we say Vitamin Ogretmen Portal to you, what does it mean for you?

In the answers given, the general opinion is that the website is very useful. The most prominent word is the expression of "development". 6 of the participants used the "professional and personal development" expression. The second most commonly used expressions were "source provider" and "sharing". Only 1 participant highlighted that it provides examples from life. In this respect, the answer given by P2 is as follows: *"Lecturing video, video examples from life, shortly it is helpful to me for my branch."* P9 stated as follows: *"Innovation, easy access, teacher colleagues who aspire after self-improvement and I am very happy to help them and to learn, share new things."* When the answers are reviewed, looking from the general frame with respect to the Vitamin Ogretmen website, it is seen that the teachers demonstrate positive attitude. They think that the website supports them in terms of development.

Question 2: Would you please mention about what the Vitamin Ogretmen Portal has gained you in the professional and personal development areas? Have you used it mainly for personal or professional or branch purposes?

According to the answers given, 4 participants mentioned only about the professional development, while 5 participants mentioned that they have gains in both personal and professional areas. 1 participant stated that it is not possible to mention about any gains on account that there isn't

any material in relation to his/her branch. It was stated that the materials in the website offers creative and diverse examples. The answer of P3 about the subject is: *"I think it is useful personally and professionally. It is helpful to us for the techniques and methods to be used in the classroom.* P1 commented as follows in this respect: *"Primarily personally. For personal development reflects consequentially to the profession, I can say in both areas."* When the answers given are evaluated, it was revealed that there is a deficiency in terms of branches. On account that there aren't lectures and sources in relation to each branch, it is seen that certain branches cannot avail of the website efficiently.

Question 3: Would you please explain how you have managed to find the opportunity to reflect the professional and personal development you have gained to your school life?

The answers in favor of increase of the education quality are the same and positive. 9 participants stated that the quality of education has increased, while 1 participant stated that there isn't any point for him/her to represent the quality of education because there isn't any document supporting his/her branch. In general, interrogating the events, gaining the problem solving skills, and enriching the lecture by creative examples were mentioned about. The comment by P7 on the subject is: *"I think that I will find the opportunity to reflect the developments I have gained to the school life when the portal's content with respect to my branch is enriched"*. P10, on the other hand, stated that: *I tried some of the methods in the classroom. I have seen that you obtain different attainments depending on the age groups. If the activities lectured are applied in the classrooms, you can rally change the atmosphere of the class. The students enjoy learning by entertaining. They get more pleasure from the school and the course."* It is seen that the participants are of the same opinion that the attainments gained from the Vitamin Ogretmen Portal make positive contributions to the courses.

Question 4: Which applications are there in the Vitamin Ogretmen Portal? Which of these applications do you use?

Live broadcasting, videos, lecture summaries, questions and writings, educational studies, videos for branches, sample lectures and the forum page are the answers given. However, 3 of the participants stated that they participate in the live broadcasting activities. 9 participants stated that they use videos for their branches and sample lectures. It is seen that there isn't any participant using the forum page. There is also a participant who considers the lecture summaries insufficient. The answer of P6 to this question is as follows: *"Lecturing, homework, tests, I make use of all."* P8's answer on the other hand is as follows: *"I follow mostly the videos and writings regarding professional development in the Vitamin Ogretmen Portal. Also I watch the sample lectures and I try to adopt such lecturing to my class as well."* The answers show that the participants are aware of the applications in the website and they use all of them. They prefer to use only those professional development videos that are related to their own branches. The reason why participations in the live broadcastings are low is identified as the broadcasting times.

Question 5: Have you ever used the Vitamin Ogretmen desktop application? If yes, what is your evaluation about it?

9 of the participants answered as no to this question. Because, it was understood that only 2 participants are aware of such application. It is seen that only one of the 2 participants who are aware of the desktop application uses it. The participant who stated that he/she uses it for it provides convenience also mentioned that he/she is satisfied with the application. The other participant who is aware of the application, however, stated that he/she has not used it because he/she has not needed it. From hence, it can be concluded that a better informing should be carried out with respect to the desktop application.

Question 6: Which lectures and lecturers take your attention most in the Vitamin Ogretmen Live Lectures?

3 individuals using the live educations responded to this question. P9 of these is as follows: *"In the live broadcastings I have watched, I liked the teaching methods and techniques, educational videos, slides, film sections and music pieces. Creativity and leadership subjects are very useful. Motivation, reading, creating strategy, mentorship and coaching, body language, and innovation attract my interest much."* P10, on the other hand, responded as: *"As subject, mostly the lectures in my own branch, classroom management and teaching techniques subjects attract my interest much. Educational management and leadership subjects are also good. As the lecturers, Nurdan KALAYCI and Necati CEMALOGLU are the*

*lecturers that I listen to with much pleasure.*" From the answers given, it is seen how useful the live broadcasting videos are. It is understood that the subjects followed mostly are the educational management and teaching techniques.

Question 7: The studies that you find generally about which area are the works that you consider as the most efficient in the Vitamin Ogretmen Portal?

The works about the educational methods and techniques were preferred by 3 participants. This is followed by the sample lectures and materials for the branches. Personal development, educational management and Turkish are among the answers given by one participant at a time. The answer by P8 about the subject is as follows: *"I find the sample lectures productive. I believe that if they were about more subjects and in each branch, they could have been more useful for us the teachers. When we see different lecturing methods with examples and apply them to our own classroom environment, the lectures will get rid of mediocrity and become more interesting. Thus, we may apply the methods we have not applied before in our courses in different ways."* P10 who expressed opinion about the subject answered as: *"In my opinion the works where different teaching methods are explained are very productive. For example, some movies are mentioned about. The movie recommendations for teachers and students to watch are also highly fruitful. They open up people's horizons."* The teaching methods and techniques, and sample lectures are the works that are found to be the most productive ones in both the live broadcast and other documents. Furthermore, it is seen that the materials included in the basis of branches are also found productive. It can be concluded that the teachers are aware of the fact that they should renew themselves in order to be able to cope with the changing student profile. Because, using different teaching methods and techniques is a must of our contemporary educational system.

Question 8: What can you say about whether the Vitamin Ogretmen Portal is sufficiently up-to-date or not? What would you like to find more in the website?

According to the answers given, 4 participants stated that they consider the portal up-to-date. 3 participants stated that they do not consider it up-to-date. And 2 participants stated that they consider it moderately up-to-date and that it could be improved further. P4 of the participants stated that he/she wants that there is information about the project preparation processes. The answer by the P7 of the participants is: *"I do not consider the website as up-to-date. There should be works that the teachers may use in the courses and that can be interesting for the students."* And the answer by the P8 is as follows: *"I don't think that the website is up-to-date. When we look at the sharings, we can see that much time has passed since the sharings. If its contents are improved a bit more, if it becomes a website where teachers can find whatever they need and share any subject in any branch, where more up-to-date subjects, news about education and training are included, then the teachers can use this website much more actively. The website is grouped based on the branches and levels, but when we look at it in terms of branches, it is hard to find up-to-date subjects and sharings. If it becomes as a website which is social on the basis of each branch, there would be no need for the teachers to access and make sharings in other websites."* As can be understood from the answers, the missing aspect of the portal is its up-to-dateness and the fact that equal materials are not offered to the branches. It is assumed that the participants finding the website up-to-date are the teachers of the main courses included in the general exams. Because materials for the main courses are given more place in the website compared to the auxiliary courses and elective courses.

Question 9: What can you say about the background of the Vitamin Ogretmen Portal?

Here, it is intended to determine whether the participants have knowledge about the kitchen of the work. According to the answers given, it is understood that 4 participants are aware of the kitchen of the work. The comment by P1 about this subject is: *"I know that Sebit and Gazi University cooperated in this work."* P7 brought a different comment in this respect: *"There should be separate studies for each educational region. The means of the schools, environment, and the economic structure of the people of that region should be taken into consideration. Regional differences should be taken into account for ensuring provision of the requirements in the studies."* Though it is normal that the teachers are unaware of the background of the portal, it is useful if they know it. Knowing who have placed efforts for and who have taken charge in and assumed responsibility for this work is the information necessary to discuss the quality of the website. It will be appropriate if the teachers have knowledge about this matter. For this reason, the kitchen of the work should be explained better to the teachers.

Question 10: Would you please share with us what you want to add about the Vitamin Ogretmen Portal?

9 Participants shared their comments about the subject. It was indicated in the comments that conducting face to face activities from time to time might be useful as well. It was stated that more branches should be given place. It was stated that in case appropriate equipment is provided in the classroom environment, the lectures will be more enjoyable. Stating that there isn't any sharing about especially the Physical Training course, it was recommended to enrich the content. It was stated that the section called discussions should be more functional. One of the deficiencies is that a questions and answers section should be added. P6 commented as: *"In fact if we have the opportunity to lecture the courses in the school with application like the vitamin, the lectures might become more enjoyable and understandable for the students."* And P9 commented that: *"I appreciate it for being a mediator for me to improve myself about the distance learning. I always learn something new while watching live broadcasts or videos. I wish we could communicate certain live broadcasts to many more teachers and introduce them the Vitamin Ogretmen; it is for sure that many of my friends would like to follow it after their initial sharings. It is important to create awareness. Best regards."* It is understood that the teachers using the Vitamin Ogretmen Portal are satisfied with the website in general. They gave certain advices thinking that it could be enriched with certain recommendations. The most important one of these advices is the matter of giving place to more branches. The desire that the courses other than main courses are given the necessary importance was also stated. Furthermore, it was concluded that the website should be promoted in a better way and it should reach more teachers, and awareness should be created in the teachers.

### **Conclusion and Recommendation**

The teachers of our age should keep step with the advancing and changing world and should use the websites where they can provide both professional and personal development. When we examine the new student profile, we recognize the fact that we are confronted with a generation that came into the world inside the technology. The teachers have fallen behind their students in terms of technology. In order to make up for this gap, also the teachers should do their part and integrate the technology into their courses. They should know that this is the only way that they attract the attention of their students and lecture properly.

The Vitamin Ogretmen Portal is a website which aims to provide professional and personal development to the teachers and which place importance to use of technology in education. When we look at the website from the viewpoint of the teachers, it can be said that it functions as a source making contributions to education and teachers with its rich content and the materials it provides. All the teachers participating in the study and using the Vitamin Ogretmen Portal stated that they consider the website highly effective. They stated that they were successful in increasing the quality of the education by conveying the information they learned to the classroom environment. There are teachers who started to use smart phones and Facebook in their courses with the information they learned from the Vitamin Ogretmen website. To be able to appeal to the students, one should speak their language. And the Vitamin Ogretmen website was designed to provide the teachers with such opportunity. The teachers are encouraged incentivized with the videos involving good examples and sample lectures.

However, the number of teachers using the website is not at a sufficient level yet. The updating is also being neglected. When a teacher whose school was changed access the website to use the Vitamin Education and when the information regarding the former school is displayed, the teacher cannot communicate with his/her students. For this reason, the user information should be followed more carefully. Necessary studies should be carried out in order to create awareness in the teachers. Media's power should be exploited. It is an undisputable fact that the website will be even more enriched when the teachers are introduced with the website and when awareness is created in the teachers. Because the teacher sharings are posted in the website, and inter-group cooperation is encouraged in the website. When limited number of people uses the website, the sharings remain limited as well. Another point having a role in why the number of teachers using the website is less is that documents from each branch are not given place at equal levels. On account that our educational system is based on



examinations and tests, more importance is placed on the main courses of which the questions are asked in the examinations. Since adequate place is not given to certain branches such as the Visual Arts, Music and Physical Training, the website has failed to gain these users. Only the content providing personal development serves all the teachers. When it comes down to the branches base, it is confronted with a situation that can be deemed as an accusation of discrimination among the teachers. But, a different approach should be taken for the matter. Instead of saying that there isn't any document regarding their branches, these teachers may prepare their own documents and present them for sharing. Instead of enjoying free-riding, they may be pioneers in their branches by placing their own efforts. If it is a teacher who is in question, then free-riding is an unbecoming situation. If there is a situation requiring a solution, the teachers should themselves be the solution.

As a conclusion, the Vitamin Ogretmen Portal is a highly efficient application despite the low number of its users. It is an important source which provides personal and professional development for the teachers, gains new approaches to the education and training environments, and makes up for a gap in the field. The videos that were prepared by working in cooperation with the academicians provide opportunity for self-improvement for the teachers. Nonetheless, involving more academicians in the work, the subjects can be lectured in a wider range. Thus, the opportunity to reach more teachers can be obtained.

### References

- Karasar, N. (2012). *Bilimsel Arastirma Yontemi*. Ankara: Nobel Akademik Yayıncılık.
- PBS.(2016). Public Broadcast Service. Retrieved 01.07.2018 from <https://www.pbs.org>
- Portal. (2015). Portal Nedir? Retrieved 12.07.2018 from <https://www.portal.nedir.com>
- Sezer, B. (2014). Calismalar, Teknoloji-Pedagoji Baglaminda Ele Alindiginda Yalnizca Donanim Saglama Projesi Olmaktan Bir Olcude Siyirilabilir, *Turkiye Bilisim Dernegi Bilisim Dergisi*. 170 (42). Ankara.
- TDK. (2014). Turk Dil Kurumu. Retrieved 17.07.2018 from <http://www.tdk.gov.tr>
- Yildirim, A. ve Simsek H. (2011). *Sosyal Bilimlerde Nitel Arastirma Yontemleri*. Ankara: Seckin Yayıncılık
- VITAMIN. (2016). Vitamin Ogretmen Dernegi. Retrieved 13.07.2018 from <http://www.vitaminogretmen.com>
- WorkCube. (2017). Workcube Association. Retrieved 15.07.2018 from <http://www.workcube.com/portal-nedir>

# Mind maps related to leadership skills of school principals

Meltem Kuscu, Hasan Arslan

## 1. Introduction

Brains of human are almost exposed to information overload in the days of digital age. It becomes difficult for us to keep information in mind against information overload. For this reason, people needed to develop various memory techniques. Graphical methods (Buzan & Buzan, 2013), three-dimensional modeling (Bulbul, 2007) and photographic memory techniques (Cecil, 2003) have become popular memory improvement and remembering methods of recent times. In this study, mind mapping technique built on organizing information is addressed. The purpose of the study is discussing leadership and mind map together and presenting different interpretations about revealing leadership skills.

### 1.1. What is a mind map?

Mind map was originated by Tony Buzan, English psychologist, mathematician and brain researcher in the late 1960's (Aydin, 2010; Butuner & Gur, 2008). It was expressed that mind maps were discovered in 1970 in some sources (Mahmud, Islam&Rawshon, 2013; Balim, Evrekli&Aydin, 2006-a). It will be good to learn the definition of mind map from Tony Buzan.

Mind map is the graphical representation of spreading thinking, spreading thought is the information pattern starting from the center and expanding to the curves by various associations (Buzan&Buzan, 2013). As expressed by Tony Buzan, a mind map covers all cortical skills such as word, letter, number, logic, rhythm, color and spatial awareness with a uniquely strong technique and in so doing; it gives the freedom to roam the infinite expanses of the brain (Buzan&Buzan, 1993).

#### 1.1.1. Advantages of a mind map

The most significant advantage of mind maps is that they enable us to use both hemispheres of brain. Mind maps improves imagination, make taking note easy, visualize the information and save time (Bulbul, 2007, p. 102). The underlying principle of mind map is not taking notes it is producing notes. Principles of mind mapping aim to increase mental freedom. Real mental freedom is the skill of creating order out of disorder. Mind mapping exactly helps it (Buzan&Buzan, 2013). There are studies on examining differences between taking notes by traditional methods and producing notes with mind maps. For instance, Aydin (2010) examined effects of mind maps on the skill of listening experimentally. According to experiment results, final test average of students taking notes by traditional methods was fell behind the final test average of students using mind maps. Briefly, mind maps improve the perception and facilitate remembering since they allow us see the phenomena one by one and the whole simultaneously. Accordingly, it provides an efficient identity. The most important of all, it saves time in fast lives.

#### 1.1.2. Areas of use of mind map

Mind maps would be used as the technique of taking notes however, it found place in a number of areas (Balim et. Al, 2006-a). Sari (2017) indicated that mind mapping method could be used in very different areas. He explained that it could be used for different purposes beyond taking notes fast and efficiently. Moreover, he expressed that we shouldn't be limited to what was told and mentioned about some of areas of use under the following titles: setting goals, preparing for the meeting, presentation preparation, reporting, combining, taking notes, brain storming.

Mind map is a technique which can be used in almost every area. In addition to it, education sector can be listed as a frequently preferred area. Studies performed about benefits of mind map in educational field yielded positive results (Aydin, 2010; Balim et al., 2006-a; Balim et al., 2006-b; Budd,

2004; Butuner&Gur,2008; Karatas,2010; Mahmud et al., 2013). Employability in other fields should be considered because of the fact that its benefit has been proven by studies in the educational field. Applications of mind mapping in different fields can be examined by the researchers.

Mind mapping method can be executed via a computer program. Instead of using paper and pen, features of mind map program in computer can be used. For instance, Ompa, Tryfonopoulos, Vassilakis and Lepouras (2014) did study on a program called OntoFM. OntoFM is recognized as a program which can be used as totally personal information management tool allowing determination of semantic links between information elements and updating in addition to being a helper to obtain the information. Balim et al., enabled students to develop mind maps by use of SmartDraw in science and technology class. By this means, they achieved both entertaining and successful study. Trial version of iMindMap program being the legal mind map software of Tony Buzan can be found at <https://imindmap.com/> (Buzan & Buzan, 2013). Moreover, Mind manager program is referred in a number of sources. Creating mind maps in computer has various advantages.

In brief, using a mind map efficiently requires perceiving it accurately. The basic role for this perception is key words. Selection of key word is important. Key words should be the most correct words to relay the opinion. A key word is specific to the person and should address to the scenario of the person. Scenario of everybody is different. In the basic form, instead of using sentence or list, an image is placed in the middle of the page. The page is covered by branching in the form of clock by use of keywords and images around the images in an organized way. While creating the branches, soft curves are used instead of sharp lines. While sharp lines add severity psychologically, soft lines make us relief (Gungor, 2005). Categorizing information with colors should be preferred because it increases the memorability. Mind maps can be created fast and efficiently by use of computer programs.

## **1.2. What is leadership?**

Lloyd Baird spoke of the first quality of a leader with the saying that “Leadership begins with knowing where and why to go” (Harvard Business School, 2006). Ercetin (2000) included a number of leadership definitions made from 1902 to 1997. It can be concluded by these definitions that leadership is influencing people by strong communication, motivating them and dreaming about the future together. Hoy and Miskel (2012) expressed that people considered leadership as “the person making a difference.” Celik (2013) emphasized the concepts of leader and leadership and defined the leadership as process of influencing and the leader as the person initiating the process.

Definitions of leadership transformed and developed in time and are the above-mentioned definitions now. Leadership is the person having the potential to trail the masses and gather the members for common purposes in the basic expression. Types of leadership and the relationship between mind maps and leadership are described in this part of the study.

### **1.2.1. Types of leadership**

Approaches of leadership are analyzed under three titles: characteristic approaches, behavioral approaches and situational approaches (Bakan&Buyukbese, 2010; Celik, 2013; Ercetin, 2000). When the literature was reviewed, it was believed that leadership skills were innate in characteristic theories. Leadership was defined as a concept which could be taught in behavioural approach. It was expressed in situational approach that the leadership might arise from unpredictable reasons and also a leader was not always necessary.

When new paradigms in leadership are analyzed, transformational leadership, cultural leadership, visionary leadership and quantum leadership may be mentioned (Ercetin, 2000). Celik defined types of leadership as educational leadership, cultural leadership, super leadership, moral leadership, learning leadership, transformational leadership, visionary leadership, quality leadership, team leadership, distributor leadership and social justice leadership. Harvard Business School (2006) spoke of charismatic leader, transformational leader and pragmatic leader. Hoy and Miskel (2012) mentioned about the concept of distributor leadership. Bakan and Buyukbese (2010) described types of leadership as autocratic leadership, leader giving a free hand, participant-democratic leader, charismatic leader and transformational-interactive leader.

### 1.2.2. Leadership and mind maps

Mind maps are ideal to define non-linear concepts that relevant opinions should be successive and leadership is a highly non-linear concept (McCreary, 2002). Because of the fact that mind maps present the whole picture and individual parts, they are perfect tools for the directors and leaders. The biggest problems for the management are not being comprehensible, lack of control and low communication. Mind maps can present the whole and parts together and therefore they may overcome these problems. At the same time, they create a cooperative environment and strengthen the bonds. Mind maps are easily accessible sources and they are not as daunting as notes and graphics. It draws attention because of its structure and makes the individual be a part of the process. Mind maps are used to improve team works. A good leader ensures that individuals are informed of skills of each other, in short, efficient team work (Buzan&Buzan, 2013). The most proper mind mapping method for team works is the group mind map method. In this method, firstly individual mind map is requested similar elements in themes are marked and a new map is created. Finally, group map is presented to the individuals and the same process is repeated on present mind map (Buzan, Dottino&Israel, 2012). Buzan and Buzan (1993) described the benefits of mind map for the management as follows:

1. Happier and more motivated labor for better management and organization. It means better public opinion image
2. Improves communication between staff members.
3. More efficient and productive training
4. Demands will increase since it is introduction-focused

A field that mind maps are associated with the leadership is the student leadership. Leadership is not only a phenomenon related to the adults. Hine (2013) emphasized the significance of student leadership and examined advantages and disadvantages of leadership experiences in students. As the great leader Gazi Mustafa Kemal Atatürk expresses all the time that Today's Children are the adults of tomorrow. For this reason, leadership skills should be introduced to the young people being the adults of tomorrow while they are students. Meyerson thinking in this way (2002) gives practical clues about how mind maps can be used to introduce leadership skills in his book called "Today's Children are the leaders of tomorrow".

In brief, a leader should know the potential of individuals in his team. By this means, it may be found out that from whom, at which level and in which area benefit can be provided. He achieves maximum performance by his team. Mind map is a very efficient tool to determine potential of the individuals. Mind map is the whole of figures that everyone presents his scenario and imagination in paper. Mind map is a nice clue showing the point of view of the individuals about the issues and reflecting the personality and how his mind works. It can be concluded that mind map is of the feature of determining performance.

A leader is responsible for training, development of individuals in his team. He should provide the opportunity of development to his team and encourage training. He can make use of these teams very well in the team. Team work is very significant for a team. A good leader should integrate development of each individual with development of the team. In so doing it, he should use communication skills. A significant way to ensure inter-personal communication is using the mind map again. Efficient results for solving a problem, designing a project, preparing for a meeting are achieved by mind map activity that everyone will participate easily. Work to last for weeks or months maybe can be concluded by mind map methods easily by saving time and labor owing to participations of all individuals. The person to ensure it is an efficient leader.

## 2. Method

This study based on examination of leadership skills of school principals by mind maps was performed by situational analysis, one of the qualitative research methods. As it can be understood by its name, situational analysis is a method used to acquire information about a situation and seeks for the answers of questions what, why and how (Metin, 2014). The aim is to reveal results related to a certain situation (Yildirim & Simsek, 2011). The problem sentence is "to which extend are school principals aware of their leadership potential? Of which leadership skills are reflected? While searching for answers of

these questions, it is aimed to determine common leadership skills of school principals and reveal inadequate leadership skills if any. By this means, it is important since it guides in-service training for school principals.

Participants are the school principals serving in Burhaniye district of Balıkesir. There are three kindergartens, 18 primary schools, 13 secondary schools, 10 high schools with private schools in the said region. In addition to it, there are vocational education center, public education center, science and art center and private education application center.

There are 50 institution principals with district director of national education and branch directors. 18 institution principals participated in the study based on volunteerism. By this means, 36% participation was achieved. Demographical information of participants is presented in Table 1. Participants are expressed in P(number) (gender, institution) in the study. For instance, P2 (E,L). P2 is used to define participant, E for gender and L for high school. Letter A is used for kindergarten, I for primary school, O for secondary school, L for high school and D for Public education center and BILSEM (Science art center).

*Table 1: Demographical information of participants*

Participant	Gender	Age	Term of being administrator	Institution	Branch
P1	E	53	15	High school	Geography
P2	E	50	4	High school	Vocational class
P3	K	40	8	Kindergarten	Pre-school
P4	E	41	3	High school	Installation techn.
P5	E	45	15	Primary school	Classroom
P6	K	52	10	Primary school	Classroom
P7	E	58	32	High school	Maths
P8	E	43	13	High school	Turkish language lit.
P9	E	41	8	High school	Physical education
P10	E	42	12	High school	History
P11	K	33	2	Kindergarten	Pre-school
P12	E	51	24	Primary school	Classroom
P13	E	33	3	Secondary school	Turkish
P14	E	47	16	Primary school	Classroom
P15	E	44	8	Primary school	Classroom
P16	E	44	12	High school	Turkish language lit.
P17	E	39	16	Public edu.	Classroom
P18	E	41	10	BILSEM	Classroom

Interview method and mind map technique was used in the study as data collection tool. The interview is the oral communication process between minimum two persons to obtain information about a certain subject (Metin, 2014). The interview is one of the most widespread data collection tools used in qualitative research, it is more efficient for benefiting from experiences and opinions of the individuals (Yildirim&Simsek, 2011).

The study was initiated with three minutes ten seconds video track to school principals and then 15-minute presentation during school visits. Following the presentation that mind maps were explained and points about leadership were reminded and a paper and crayons were distributed to the school principals and asked to draw a mind map related to their perception about their leadership skills. It was assumed that participants were since while they were drawing. Papers were delivered after the drawings lasting for about 15 minutes. Mind maps collected were examined by content analysis and themes were obtained.

### 3. Findings and comments

Firstly, two questions were asked prior to drawing. The first one is “How many leadership trainings have you participated in before?” and the other question is “Have you ever heard about mind maps before?” According to the answers of participants, a participant has not received leadership training. Five participants indicated that they received one training and five participants received two training and three participants received three trainings and four participants received four trainings. One participant expressed received 20-leadership trainings since he was a member of Teacher Academy Foundation and an instructor and also he provided 50 leadership trainings at various seminars. 13 participants answered the question of “Have you ever heard about mind maps before?” as yes and five participants answered that they had not heard about it before.

Mind maps drawn by the participants were examined by content analysis and themes were prepared. Drawings were evaluated based on each theme. Accordingly, themes prepared are trust, communication, collaboration, justice, innovativeness, conciliation. Other contents in the drawings of participants were presented collectively following the themes.

#### Theme 1: Trust



Figure 1: Parts related to trust in the drawing of P11 (K, A)



Figure 2: Parts related to trust in the drawing of P2 (E, L)

Theme of trust was expressed as in examples in Figure 4 and Figure 5. While trust was expressed in nine of 10 drawings handling the theme of trust, one drawing demonstrated distrust. When drawings were examined, it was seen that the theme of trust was associated with the personnel by four participants. Three of participants presented the theme of confidence by associating it with transfer of authority, three of them associated it with a part of institution culture and one of them associated it with accountability and one of them associated it with justice. P2 (E,L) presenting the single negative opinion associated distrust with the staff. Importance attached to the trust for leadership skills by the principals is understood by the drawings. Especially, it is understood that they emphasize the trust they put in vice principals by associating it with transfer of authority and in institution culture by associating it with the staff. It is seen in the drawing with the negative answer that the word of frustration is presented in the drawing. It can be concluded that difficulties that the participant named P2 (E,) had with the staff at the institution led to the problem of trust.

### Theme 2: Communication

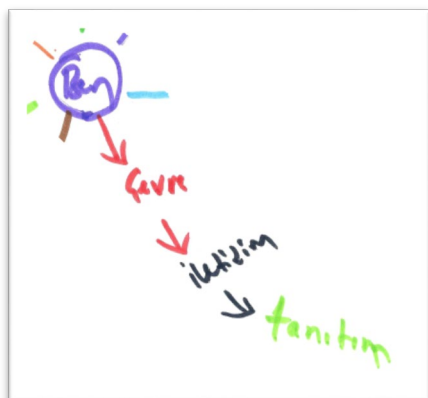


Figure 3: theme of communication in P10 (E, L) drawing

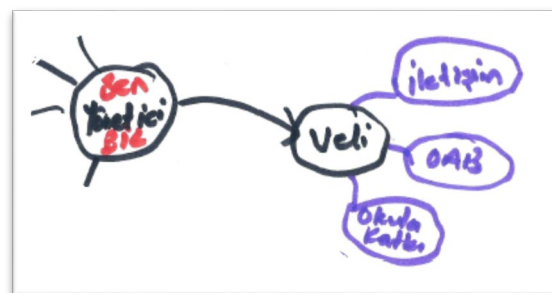


Figure 4: theme of communication in P15 (E, I) drawing

Theme of communication was used by nine participants with various expressions. Examples of communication theme are presented in Figure 6 and 7. Five of participants associated the theme of communication with the environment. Concept of environment was expressed as parent in some drawings and directorates of national education in some drawings. It was expressed as directly environment in some drawings. Three of participants handled the theme of communication alone. One participant associated the theme of communication with the concept of sharing. Drawings of communication theme show the importance attached by the institution principals to the communication within the scope of leadership skills. Participants associating the communication with introduction considered the theme in terms of self-expressing of the institution. It can be concluded that institution principals consider their institutions as a system and they attach importance to the communication with the environment.

### Theme 3: Collaboration (being us)



Figure 5: theme of collaboration in P4 (E, L) drawing



Figure 6: theme of collaboration in P3 (K, A) drawing

Theme of collaboration were included in drawings by eight participants in different forms. In figure 8 and 9, drawings that the theme of collaboration is shown by emphasizing “being us”. It was seen when the drawings under the theme of collaboration were examined that four participants emphasized “being us” two participants mentioned about direct collaboration. One participant associated the theme of collaboration with the parent and other participant associated it with the teacher. While analyzing drawings of institution principals of leadership skills, almost half of the principals met attached importance to collaboration at their institutions. It can be concluded that general perception of institution principals being aware of the importance of ensuring coordination at their institution related to the concept of collaboration is the phenomenon of “being us” or “being uniting” .

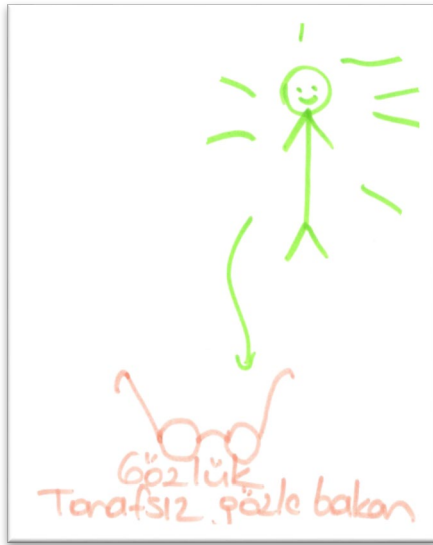
**Theme 4: Justice**

Figure 7: theme of justice in P13 (E, O) drawing

Examples of drawings of theme of justice emphasized with the expressions of justice, equality and objectivity are presented in figure 10 and 11. Theme of justice was expressed by six participants. While three of participants associated the theme with the word of objectivity, one participant included it in the drawing as trust-based, one participant included it as student, personnel and parent-based justice and one participant included it as justice directly. Because of the reason that fewer than half of the institution principals referred the theme of justice, it can be said that the concept of leadership skills is perceived by the institution principals partly.

**Theme 5: Innovativeness**

Figure 9: Innovativeness theme in P8 (E, L) drawing



Theme 8: theme of justice in P6 (K, I) drawing

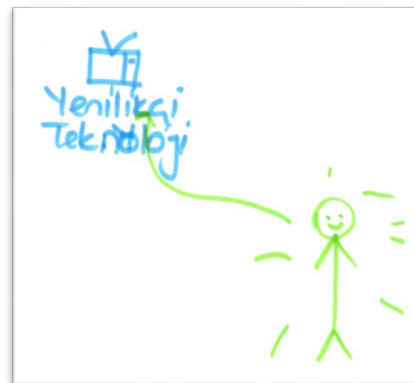


Figure 10: Innovativeness theme in P13 (E, O) drawing

Theme of innovativeness was drawn by the five participants. Examples of innovativeness are shown in Figure 12 and 13. Theme of innovativeness was associated with being open to innovations and therefore progresses, contingency, technology, believing in change and having a vision by a participant. Drawings show that institution principals demonstrate a leadership away from being innovative and visionary. It can be said that only five participants mention about innovativeness, contingency of visionary may indicate a deficiency in leadership trainings. It can be concluded that institution principals are closer to the type of conventional usual institution principal rather than leadership.



### Theme 6: Conciliation



Figure 11: theme of conciliation in P4 (E, L) drawing

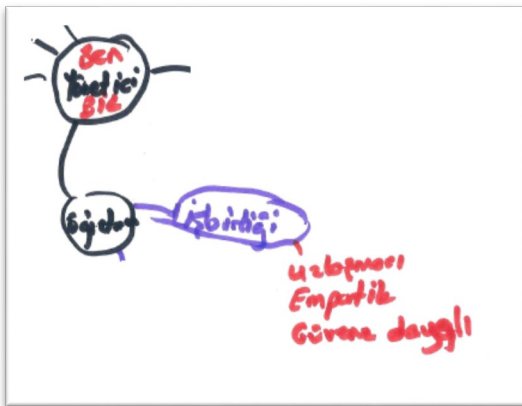


Figure 12: theme of conciliation in P15 (E, I) drawing

Theme of conciliation was drawn by five participants. Two participants associated the conciliation with personnel. One participant associated it with preventing sedition and not stopping the dialogue. One participant used it with empathy and trust under the title of teacher and collaboration. One participant considered conciliation as a direct one article. There may be two explanations of only five institution principals mentioned about conciliation. The first one is that accommodation at the institution is the top and the other one is that the institution principal does not display compromising attitude or not being able to demonstrate it. Especially, it is understood by fewer drawings of principals that they employ methods of persuasion, listening and exercising the authority to solve the conflicts.

In few drawings other than above-mentioned, status of crisis, sharing, respect, love, sincerity, empathy, listening, conflict, transparency, transfer of authority, sympathy, technology, embracing, contingency, appraising and financial condition are presented. When the drawings are analyzed in general, it can be concluded that leadership skills that the institution principals suppose to have are closer to the leadership as the communication skills and classical understanding as managerial processes. The fact that information relationships are appreciated is another result derived from drawings. Few principals' being inclined to visionary may reveal the necessity of reviewing the leadership trainings. Examples of some different drawings are blow. In figure 16, it is seen that conflict, transparency, status of crisis and school culture are referred. In figure 17, a self-confident leader profile is presented.

#### 4. Result and recommendations

When information in the literature is analyzed, it is seen that mind maps are of quite importance for a leader. Mind maps increase the efficiency and strengthen the communication for both individual work and group works. The leader respects the opinions of individuals to show that they are important for him and takes care of them and enables them to participate in decision making. In so doing it, if he uses mind maps efficiently, he will gain the trust of his colleagues and ensure efficient team work and organizational commitment. It can be concluded that it will affect job satisfaction and sense of belonging in individuals participating and thinking that they are regarded. It will mean the success. It will lead to health work environment. In short, a leader can use mind maps efficiently to be effective.

Mind maps that institution principals drew their leadership skills were examined in the study. It was seen that half or more than half of participants demonstrated leadership skills in trust, communication and collaboration. In addition to it, it was observed that more than half of participants did not mention about innovativeness, contingency, justice and conciliation. It may mean that institution principals don't think of having these characteristics and also leadership trainings are not adequate. Representing important concepts such as respect, love, sharing, empathy, sincerity, appreciation in very few drawings may be the indicators of deficiency in leadership characteristics. Considering the number of leadership trainings provided to the institution principals, it may be concluded that content should be reviewed.

These studies are related to the leadership skills of school principals and also can be used for assessing different skills. In addition to leadership skills, institution principals may be encouraged to display different skills by mind map method. By this means, potential of institution principals will be recognized and for the sake of utilizing the sources efficiently, environments that institution principals may be employed based on their skills may be created. In addition to it, deficiencies may be made up by in-service trainings by determining deficiencies.

#### 5. References

- Aydin, G. (2010). Zihin Haritalama Tekniginin Dinleneni Anlamaya ve Kaliciliga Etkisi, *Ataturk Universitesi Sosyal Bilimler Enstitusu Dergisi*, Erzurum.
- Bakan, I. ve Buyukbese, T. (2010). Liderlik "Turleri" ve "Guc Kaynaklari"na Iliskin Mevcut-Gelecek Durum Karsilastirmasi, *KMU Sosyal ve Ekonomik Arastirmalar Dergisi*, 12 (19), 73-84.

- Balim, A. G., Evrekli, E. ve Aydın, G. (2006-a). Fen ve Teknoloji Öğretiminde Zihin Haritaları ve SmarDraw Uygulamaları. Gazi Üniversitesi Eğitim Fakültesi, Ankara: 7. Ulusal Fen Bilimleri ve Matematik Eğitimi Kongresi. (7-9 Eylül 2006).
- Balim, A. G., Aydın, G. ve Evrekli, E. (2006-b). Fen ve Teknoloji Öğretiminde Zihin Haritaları ve Kavram Haritaları Kullanmanın Önemi. Famagusta, Turkish Republic of Northern Cyprus: VI. International Educational Technologies Conference.
- Budd, J. W. (2004). Mind Maps As Classroom Exercises, *Journal of Economic Education*, Winter Edition, s: 35-46.
- Buzan, T., Dottino, T. & Israel, R. (2012). *Akıllı Lider*. İstanbul: Alfa Yayıncılık.
- Buzan, T. (2005). *Hızlı Okuma*. İstanbul: Alfa Yayıncılık.
- Buzan, T. ve Buzan, B. (1993). *The Mind Map Book – how to use radiant thinking to maximize your brain's untapped potential*. London: BBC Books.
- Buzan, T. ve Buzan, B. (2013). *Zihin Haritaları – yaratıcılığınızı ortaya çıkarır, hafızanızı güçlendirir, hayatınızı değiştirir*. İstanbul: Alfa Yayıncılık.
- Bulbul, M. S. (2007). *Kaos ve Eğitim*. Ankara: Beyaz Kalem Yayınevi.
- Butuner, S. O. ve Gur, H. (2008). Acılar ve Üçgenler Konusunun Anlamlı Öğrenme Araçlarından V Diyagramları ve Zihin Haritaları Kullanılarak Öğretimi, *Necatibey Eğitim Fakültesi, Elektronik Fen ve Matematik Eğitimi Dergisi*, 2(1). Balıkesir.
- Cecil, J. (Yönetmen). (2003). *Human Mind – Get Smart*. UK: BBC.
- Celik, V. (2013). *Eğitimsel Liderlik*. Ankara: Pegem Akademi.
- Ercetin, S. (2000). *Lider Sarmalında Vizyon*. Ankara: Nobel Yayın Dağıtım.
- Gungor, S. (2005). Görsel Kompozisyonun Bir Ögesi Olarak Çizgi/Line As An Element Of Visual Composition. *Güzel Sanatlar Enstitüsü Dergisi*, (15), s: 85-100.
- Harvard Business School. (2006). *Liderlik – Pocket Mentor*. Harvard Business School Press: Optimist Yayıncılık.
- Hine, G. (2013). Student Leadership Experiences: A Case Study, *Leading & Managing*, 1 (11), s. 32-50.
- Hoy, W. K. ve Miskel, C. G. (2012). *Eğitim Yönetimi – Teori, Araştırma ve Uygulama*. Ankara: Nobel Yayın Dağıtım.
- Karatas, S. (2010). BOTE Öğretmen Adaylarının Mesleklerine İlişkin Zihin Haritalarının Analizi, *Ahi Evran Üniversitesi Eğitim Fakültesi Dergisi*, 1 (11), s:159-173. Kırşehir.
- Mahmud, I., İslam, Y. M. ve Rawshon, S. (2013). Engineering Creativity by Using Computer Aided Mindmap, *American Journal of Engineering Research (AJER)*, 7 (2), s:28-32.
- Metin, M. (2014). *Kuramdan Uygulamaya Eğitimde Bilimsel Araştırma Yöntemleri*. Ankara: Pegem Akademi.
- Meyerson, H. (2002). *Today's Teens Tomorrow's Leaders*. Dallas, Texas, USA: The Confidence Center.
- McCreary, D. (2002). A Leadership Mindmap, University of Saint Thomas.
- Rompa, J., Tryfonopoulos, C., Vassilakis, C. ve Lepouras G. (2014). Mindmap-Inspired Semantic Personal Information Management, *Open Proceedings*, s: 608-611, <https://openproceedings.org/2014/conf/edbt/RompaTVL14.pdf>, Access Date: 22.08.2017.
- Sari, E. (2017). *Beyin Gücü*. Antalya: Net Medya Yayıncılık.
- Yıldırım, A. ve Simsek H. (2011). *Sosyal Bilimlerde Nitel Araştırma Yöntemleri*. Ankara: Seckin Yayıncılık.

# Determination The Opinions Of The Secondary School Teachers Regarding The Use Of Mobile Technologies For Educational Purposes

Ismail Colak, Nejat Ira, Aynur Gecer

## 1. Introduction

While the constantly progressing science and technology expand their borders it creates awareness of the fact that the world is not as enormous as it is considered to be. Thanks to science and technology, a new tool, appliance, machine or software become an indispensable piece of our families or works. In today's digital era, the necessary time to reach out the information is measured by seconds. The most significant factor that causes this is the mobile phones, tablets, and laptops that have fast processors and that have become accessible to the wide masses with their cheap models which can be accessed remotely with their wireless internet and these gadgets have been accepted and adopted by these masses. While all of these advancements have been changing the lifestyles of the individuals, the integration of these to the education has changed our way of learning, as well. This new learning method of ours, mobile learning, is the learning that is formed by the joint use of mobile tools and technologies that have enabled the learning without any time or place restrictions. Mobile learning is defined as the educational practices that are being provided with PDAs (individual digital assistant or minicomputer) and smartphones (Keegan, 2005, Arslan,2018). On the other hand, Trifanova (2003) labels the mobile learning as any kind of teacher or learning events practiced the mobile technologies and tools by integrating with the mobile peripheries.

According to TUIK 2016 reports, %96,9 of the houses in Turkey have mobile phones. When the internet usage purposes checked, it is seen that the internet is used for social media, again ranks the first, followed by video watching and newspaper and magazine reading. Thus, it has become inevitable that the use of mobile devices that are used intensely by the nowadays students in education, in connection with e-learning which is widely used in education, e-learning has also started to be widely used. One of the applications that increased the spread of the mobile technologies' use learning-teaching processes in our country. The Ministry of Education launched "the Fatih Project" in 2011 in an attempt to pervade the technology in education, the smart boards installed in almost all the high and secondary schools in Turkey and the tablet computers are disturbed to the students. According to the 2015-2016 statistics of the Ministry of Education, 17 million 558 thousand students from the pre, primary, and secondary school institutions and 1 million teachers are in this scope. (MEB 2017) In order to be able to keep up with the digitalized student profile of the modern world, one needs to know the students' world. Summarize, one must own a magical key in order to attain the students. One needs to know, recognize, use, and produce mobile learning and its applications. In this case, the teachers are to carry very significant duties. They must develop themselves and become digital citizens. In this regard, through this research, the opinions of the teachers who use the mobile learning and its technologies in today's schools and classrooms during the teaching activities are assessed.

### 1.1. The Purpose and the Importance of the Research

The aim of this research is to detect the opinions of the secondary school teachers regarding the mobile learning. The sub-purposes in order to reach out to the developing purpose are as follows: The Secondary School Teachers;

1. Which and how the mobile tools are used during the teaching activities?
2. How do they decide which mobile tools they will use in the teaching activities?
3. What are their opinions about the changes in their teaching practices that have occurred since they started using mobile tools?
4. How do they define a successful or failed course supported by mobile tools?

5. How do they define mobile learning in their own words?
6. What are their opinions regarding the contribution of the Fatih Project to mobile learning?
7. What are their opinions on the successful integration of mobile learning into teaching activities?
8. What are their opinions on the use of mobile learning in teaching activities effects on the success of the student and the processing of the course positively and negatively?
9. What are their opinions on the obstacles that appear during the integration of the mobile learning tools to the learning and teaching activities?
10. What are the opinions of the secondary school teachers regarding the obstacles of the manager support, personal interest, vocational development/training that the teachers encounter in the integration of the mobile learning tools to the educational activities?
11. What are the opinions of the secondary school teachers regarding the obstacles of the technological restrictions, budget restrictions that the teachers encounter in the integration of the mobile learning tools to the educational activities?

## **2. METHOD**

### **2.1 The Model of the Research**

In this research, the qualitative research model is used. The descriptive and explanatory case study is used as a figurative approach. The content analysis is used in the analysis of the obtained data in this research. The content analysis is the process which, in an understandable way, edits and interprets the similar data within the frame of certain concepts and themes by bringing them together. (Yildirim and Simsek, 2006)

### **2.2 The Working Group of the Research**

The working group of the research is formed by 15 teachers who work in different secondary schools and various branches in the fall semester of the 2017-2018 educational year in Kocaeli. When the dispersion rates regarding the personal characteristics of the research group are evaluated, the demographical features of those who attended the research; from the aspect of gender 60% women, 40% men, from the aspect of professional seniority 13.3% 0-5 years, 60% 6-10 years, 20% 11-15 years, 13.3% have 16+ years of experiences, 20% in Science, 13.3% in Social Sciences, 20% in Turkish Language, 13.3% in Math, 20% in English, and 13.3% work in Religion branches. It is seen that this research consists of the participants with 100% teachers titles. It can be concluded that the participants are comparatively spread according to the gender and duty titles, in professional experiences the teachers with 6-10 years and 11-15 years are the majority, and the distribution on the basis of the branches are equal.

### **2.3 Data Collecting Tools**

The data of the research is obtained by the semi-structured interview form. The interview technique is the controlled and oriented communication way which takes place between the researcher and the person who is the subject of the topic. (Cohen and Manion, 1994) In the research, in which the qualitative research model is used, in order to gather the data the personal information form is prepared by the researchers in advance. Along with this form, by doing field scan and by taking the expert's opinions (6 academics who work under BOTE and the Education Management Audit) an interview form which contains the open-ended questions that detect the opinions of the secondary school teachers regarding the use of mobile technology is prepared. The first 5 of the open-ended questions are taken from Tsai and Hsieh (2017) work. Other than the questions in the interview form, during the interview, the teachers' opinions are taken regarding the obstacles that they come across while integrating the mobile learning to the mobile learning-teaching processes. The questions in the interview form are as follows:

1. Which and how mobile tools do they use?
2. How do they decide which mobile tools they would use in the teaching activities?

3. What are the changes in their own teaching activities since they started using the mobile tools in the teaching activities?
4. How do they define a successful and a failed course supported by the mobile tools?
5. How do they define the mobile learning with their own words?
6. What is the contribution of the Fatih Project to the mobile learning?
7. What does need to be done in order to integrate the mobile learning successfully to the teaching activities?
8. What are the positive and negative effects of the use of the mobile learning in the teaching activities for the success of the students and the processing of the course?

#### **2.4. The Analysis of the Data**

All the face-to-face interviews that are conducted by the researches are written. The coding process of the data from the interview forms is done. The expressions uttered by the secondary school teachers, who have responded to survey form, have not been subject to any kind of change or edit. Instead of the names of the participant teachers codes such as 1O (Teachers), 2O etc. Sample expressions that reflect the administrators' opinions are presented in "quotations". The data is organized according to the themes put forth through the research questions. By analyzing the obtained data in the research the codes are given to these expressions which form a meaningful whole within itself by the first researcher who conducted the research. As a result of these codings, 100 codes are formed at the end of analyzing the total forms. The second and the third researchers from all of the researchers examined the analysis done by the first researcher for the purpose of detecting the distribution of the opinions recorded in written texts that belong to the teachers from the aspects of codes and themes and their convenience. Conducting a different coding for the content analysis by another person except for the researcher him/herself in order to examine the data and as a result of comparing them to the results of the researcher and then assessing made it clear that there was a 80% consensus provided the credibility of the done coding and this proportion shows that the credibility of the research is quite high. (Buyukoztur ve oth., 2009) Miles and Huberman formula is used in security assessments of the qualitative data. Formula:

[Reliability= Agreement/ (Agreement + Disagreement) x 100]

The reliability of the study was calculated to be 82%.

In the analysis of the data obtained in the research, the content analysis is used. What intended is to realize in the content analysis is to reach out the concepts and relations that can explain the collected data. Primarily obtained data in the content analysis is read out by the researchers and suitable codes are formed. Then, by organizing the codes and the themes the findings are prepared. The direct quotations of the administrators' opinions are presented within quotations.

### **3. Findings and Interpretation**

In this section of the research, the written opinions of the secondary school teachers regarding the mobile learning are compared and the obtained data from the semi-structured interview forms for the purpose of the examination is analyzed.

#### **3.1 Which and How Mobile Tools Do the Secondary School Teachers Use?**

The results, shown in Table 1, are prepared in line with the opinions of the secondary school teachers regarding which and how mobile tools they use during the teaching activities.

Table 1. The Opinions of the Secondary School Teachers Regarding Which and How Mobile Tools They Use During the Teaching Activities.

<b>The Mobile Tool Used</b>	<b>How the Mobile Tool Is Used</b>	<b>N</b>	<b>%</b>
Mobile Phone	Momentary Information Need	8	53,3
Mobile Phone	Momentary Communication	4	26,7
Mobile Phone/Tablet/Laptop	Reflecting the Visual Data on the Board	15	100
Mobile Phone/Tablet/Laptop	Following DYNED and EBA applications	6	40
Mobile Phone/Tablet/Laptop	Supporting the Topic	2	13,3
Mobile Phone/Tablet/Laptop	Sharing Regarding My Field	2	13,3
Mobile Phone/Tablet/Laptop	Social Media Follow-Up	1	6,66
Mobile Phone/Tablet/Laptop	Entertainment Game at the end of the Topic	1	6,66

When Table 1 is analyzed, all of the teachers (%100) state that they “use the mobile tools in order to reflect the activity of the course to the smartboard.” 40% of them state that they “use the mobile tools in Eba and Dyned applications” provided by the Ministry of Education. 13.3% of the teachers claim that they “take support from the mobile tools while lecturing.” 13.3% of them remark that they use the mobile tools in sharings regardings their own fields, %6.6 of them suggest that they use them in following-up the social media, and 6.6% say that they use it at the end of the course in order to entertain the students.

### 3.2 How the Secondary School Teachers Do Decide Which Mobile Tools They Would Use in the Teaching Activities?

The results, shown in Table 2, are prepared in line with the opinions of the secondary school teachers regarding how they decide which mobile tools they would use in the teaching activities.

Table 2. The opinions of the secondary school teachers regarding which mobile tools they would use in the teaching activities.

<b>The Reason Why the Mobile Tools Are Chosen</b>	<b>Chosen Mobile Tool</b>	<b>N</b>	<b>%</b>
The Content of the Course	Laptop/Tablet	15	100
The Activity of the Course	Laptop/Tablet	15	100
The Mobile Tools That Can Be Obtained by the Students	Mobile Phone/Tablet/Laptop	4	26,4
The Ease of Use in Regard of Branch	Laptop/Tablet	1	6,66
In Regard of the Facilities of the School	Mobile Phone/Tablet/Laptop	1	6,66
By Thinking On My Own	Mobile Phone/Tablet/Laptop	1	6,66

Determination The Opinions Of The Secondary School Teachers Regarding

Programs and Applications That Can Give Me Fast Feedback	Mobile Phone/Tablet/Laptop	1	6,66
The Tools Through Which I Can Give the Course Three Dimensional	Mobile Phone/Tablet/Laptop	1	6,66
If Momentary Info Flow Is Necessary	Mobile Phone	1	6,66

When Table 2 is analyzed, all of the teachers (100%) claim that they use the mobile tools according to “the content of the course” and “the activity of the course.” 26.6% of the teachers say that they try to choose “the mobile tools that can be accessed by the students.” 6.66% of them utter that they use “the mobile tools convenient to their branches.” 6.66% of them express that “the facilities of the schools”, 6.66% say that “by thinking themselves”, 6.66% stress that “the applications and programs through which the students can have fast feedbacks”, 6.66% remark that “the tools through which the courses can be given three dimensional” and 6.66% say that they choose the mobile devices in which “info flow is necessary.”

### 3.3 What Are the Opinions of the Secondary School Teachers Regarding the Changes in Their Own Teaching Activities Since They Started Using the Mobile Tools?

The results, shown in Table 3, are prepared in line with the opinions of the secondary school teachers regarding the changes in their own teaching activities since they started using the mobile tools.

Table 3. The opinions of the secondary school teachers regarding the changes in their own teaching activities since they started using the mobile tools.

Has there been any change in teaching practice?	The changes happened in teaching practices	N	%
		15	100
	I started using more visual and audial tool and material.	7	46,6
	More effective learning and fertility increased.	10	66,6
	Went away from the orthodox ways.	7	46,7
	The participation and activiness of the students rose.	7	46,7
Yes, there has been change.	Permanency increased.	6	40
	Time-saving provided.	3	20
	Abstract concepts are better learned.	5	33,3
	I can do more activities and experiments in the lecture.	5	33,3



The quality in education increased.	3	20
Time spared for the student rose.	2	13,3
The course is funnier.	2	13,3
We acquired momentary feedback.	1	6,66
I need to get prepared earlier for the course.	4	26,7
We started solving more problems.	3	20
Repetition number of the courses increased.	3	20
We started learning new teaching techniques.	2	13,3
Teaching activities started continuing in and out of the school.	2	13,3
Homework controls became easier.	1	6,66
Planned lecturing started.	1	6,66

When Table 3 is analyzed, all of the teachers give their opinions that with the entrance of the mobile tools to their lives there has been a change in the teaching activities. 46.6% of the teacher say that “I started using more visual audial tool and material”, 66.6% of them say that “the effectiveness of fertility of the course increased”, 46.7% say that they “went away from the orthodox ways”, 46.7% say that “the participation and activeness of the students rose”, 40% say that “permanency increased”, 20% say that “time-saving is provided” and 33.3% say that “abstract concepts are better learned.” 33.3% say that “I can do more activities and experiments in the lecture” 20% utter that “the quality in education increased”, 13.3% suggest that “time spared for the students rose”, 13.3% claim that “the course is funnier”, 6.66% utter that “we acquired momentary feedback”, 26.7% say that “I need to get prepared earlier for the course”, 20% say that “we started solving more problems”, and “repetition number of the courses increased.” 13.3% say that “we started learning new teaching techniques” and “teaching activities started continuing in and out of the school” 6.66% utter that “homework controls became easier” and “planned lecturing started.”

On the other hand, 13.3% of the administrators say that “I started preparing the teaching activities on my own”, and “the creativeness of the students increased” 6.66% say that “learning independent of time and place”, “I started sharing the programs made by me with the colleagues”, and that “I started reaching out to wide masses.”

### **3.4. How Do the Secondary School Teachers Define a Successful and a Failed Course Supported by the Mobile Tools?**

The results, shown in Table 4, are prepared in line with the opinions of the secondary school teachers regarding how they define a successful and a failed course supported by the mobile tools.

## Determination The Opinions Of The Secondary School Teachers Regarding

Table 4. The opinions of the secondary school teachers regarding how they define a successful and a failed course supported by the mobile tools.

<b>A successful course conducted with the support of the mobile tools</b>	<b>N</b>	<b>%</b>	<b>A failed course conducted with the support of the mobile tools</b>	<b>N</b>	<b>%</b>
If it is pre-planned, and the convenient tools for mobile learning is used it is successful.	3	20	If it is not planned and does not give the gainings it is failed.	3	20
If the student is active it is a successful course.	3	20	If the student is not active in a course supported by the mobile tools, it is failed.	3	20
If the student answers the questions correctly at the end of the course it is successful.	1	6,66	When the mobile technology is used in an excessive and unproductive way it is failed.	3	20
I use the mobile tools during the course very often, it provides time-sving thus it is successful.	1	6,66	If the answers given at the end of the course are negative it is failed.	1	6,66
The course with an all-participation is successful.	1	6,66			
If it can be put in minds, it is successful.	1	6,66			
If it acquire %100 success it is successful.	1	6,66			
If it can draw attention and be used in certain times of the course, it is successful.	1	6,66			
If the learning level of the course and topic is high it is successful.	1	6,66			
If the student answers the question asked at the end of the course correctly, it is successful.	1	6,66			
It is a successful course if it puts the words in minds by using mobile tools.	1	6,66			

When Table 4 is analyzed, 20 of the teachers say that "If it is pre-planned, and the convenient tools for mobile learning are used it is successful" and "if the student is active it is a successful course." 6.66% say that "if the student answers the questions correctly at the end of the course it is successful." Also, 6.66% of the teachers utter that "I use the mobile tools during the course very often, it provides time-saving thus it is successful" and "The course with an all-participation is successful" and "If it can be put in minds, it is successful" and "If it acquires 100% success it is successful" and "If it can draw attention and be used at certain times in the course, it is successful" and "If the learning level of the

course and topic is high it is successful” and “If the student answers the question asked at the end of the course correctly, it is successful” and “It is a successful course if it puts the words in minds by using mobile tools.”

On the other hand, 20% of the teachers define a failed course as “if it is not planned and does not give the gainings it is failed.” Also, 20% of the teachers say that “When the mobile technology is used in an excessive and unproductive way it is failed” and 6.66% of them suggest that “If the answers given at the end of the course are negative it is failed.”

### 3.5. How Do the Secondary School Teachers Define the Mobile Learning With Their Own Words?

The results, shown in Table 5, are prepared in line with the opinions of the secondary school teachers regarding how they define the mobile learning with their own words.

Table 5. The opinions of the secondary school teachers regarding how they define the mobile learning with their own words.

<b>The Teacher Definitions Regarding the Mobile Learning</b>		
<b>Definition</b>	<b>N</b>	<b>%</b>
It is the self-learning by using the mobile tools.	2	13,33
Making the teaching permanent with the images.	2	13,33
Education everywhere, without time or place restrictions. Learning without being restrained in classroom and class hours.	1	6,66
The education which is conducted by bringing the electronic devices together with the internet.	1	6,66
It is the transfer of the portable mobile tools to education.	1	6,66
Learning by seeing and hearing.	1	6,66
Learning in a very little time with much fun.	1	6,66
It supports the intriguing learning.	1	6,66
The use of more tools effectively in education.	1	6,66
Learning of the digital learning era.	1	6,66
Individualization of the technology in education.	1	6,66
Realizing the education by having the support of the mobile tools.	1	6,66
The latest version of the modern learning.	1	6,66

When Table 5 is analyzed, it is seen that the definitions of the secondary school teachers regarding how they define the mobile learning greatly vary from each other. 13.3% of the teachers say that “it is the self-learning by using the mobile tools” and “making the teaching permanent with images.” 6.66% suggest that it is “education everywhere, without time or place restrictions. Learning without being restrained in classroom and class hours” and “the education which is conducted by bringing the

## Determination The Opinions Of The Secondary School Teachers Regarding

electronic devices together with the internet” and “it is the transfer of the portable mobile tools to education” and “learning by seeing and hearing” and “learning in a very little time with much fun” and “it supports the intriguing learning” and “the use of more tools effectively in education” and “learning of the digital learning era” and “individualization of the technology in education” and “realizing the education by having the support of the mobile tools” and “the latest version of the modern learning.”

### 3.6. What Are the Opinions of the Secondary School Teachers Regarding the Contributions of the Fatih Project to the Mobile Learning?

The results, shown in Table 6, are prepared in line with the opinions of the secondary school teachers regarding the contributions of the Fatih Project to the mobile learning.

Table 6. The opinions of the secondary school teachers regarding the contribution of the Fatih Project to the mobile learning.

Opinions	N	%
Yes, it contributed to the mobile learning.	15	100
It added the content richness (EBA contents) to the course.	15	100
The use of the smartboard supported the course.	14	93,3
It supported the technological infrastructure at the school.	14	93,3
The number of questions and samples presented in the course increased.	5	33,3
It creates excitement in the students during the course.	3	20
It eased the homework sending.	5	33,3
The course draws attention.	2	13,3
The learning pace increased.	2	13,3
The learning willingness increased.	2	13,3
Equal opportunity (within the country) increased.	2	13,3
It made the homework checking easier.	5	33,3
It provided time-saving.	5	33,3
Education went on in and outside the school.	1	6,6
Awareness increased.	2	13,3

The topics concreted.	2	13, 3
Watching videos regarding the course.	5	33, 3
Attention to the course increased.	4	26, 4
The content grows richer.	1	6,6 6
Technological literacy develops.	1	6,66
The teacher can use the different applications freely.	1	6,66
We can do the experiments, which are hard to carry out in reality, in 3 dimensional.	1	6,66

---

When Table 6 is analyzed, all of the secondary school teachers suggest regarding the contributions of the Fatih Project to the mobile learning that “yes, it contributed to the mobile learning” and “it added the content richness (EBA contents) to the course.” Furthermore, 93.3% of the teachers say that “the use of the smartboard supported the course” and “the number of questions and samples presented in the course increased.” 33.3% of them suggest that “the number of questions and samples presented in the course increased” and “it eased the homework sending.” 20% of the utter that “it creates excitement in the students during the course.” 13.3% say that “the course draws attention” and “the learning pace increased” and “the learning willingness increased” and “equal opportunity (within the country) increased.” 33.3% suggest that “it made the homework checking easier” and “it provided time-saving.” 6.66% say that “education went on in and outside the school.” 13.3% remark that “awareness increased” and “the topics concreted.”

### **3.7. What Are the Opinions of the Secondary School Teachers Regarding the Integration of the Mobile Learning to the Teaching Activities?**

The results, shown in Table 7, are prepared in line with the opinions of the secondary school teachers regarding the integration of the mobile learning to the teaching activities.

## Determination The Opinions Of The Secondary School Teachers Regarding

Table 7. The opinions of the secondary school teachers regarding the integration of the mobile learning to the teaching activities.

Opinions	N	%
The teacher's ability to use the mobile tools.	5	33,3
Handling the infrastructure problem in the schools.	8	53,3
Lecturing the students on how to use the mobile tools.	8	53,3
Lecturing the teachers on how to use the mobile tools.	6	40
The students' ability to use the mobile tools.	4	26,7
Teacher's ability to prepare a good course plan.	4	26,7
Providing and giving the equipment, and the mobile tools to the teacher and the student.	4	26,7
Preparing an interactive program.	2	13,3
Creating a convenient content.	1	6,66
Reaching out to more students with the high-speed wire internet faster and more.	1	6,66

When Table 7 is analyzed, it is seen that 33.3% of the teachers suggest that in the integration of the mobile learning to the teaching activities "the teacher's ability to use the mobile tools" matters. 53.3% of them say that "lecturing the students on how to use the mobile tools" 40% of them say that "lecturing the teachers on how to use the mobile tools." 26.6% suggest that "the students' ability to use the mobile tools" and "teacher's ability to prepare a good course plan."

### 3.8. What Are the Opinions of the Secondary School Teachers Regarding the Positive and Negative Effects of the Use of the Mobile Learning in the Teaching Activities for the Success of the Students and the Processing of the Course?

The results, shown in Table 8, are prepared in line with the opinions of the secondary school teachers regarding the positive and negative effects of the use of the mobile learning in the teaching activities and the success of the students and the processing of the course.

Table 8. The opinions of the secondary school teachers regarding the positive and negative effects of the use of the mobile learning in the teaching activities for the success of the students and the processing of the course.

<b>Positive Opinions</b>	<b>N</b>	<b>%</b>	<b>Negative Opinions</b>	<b>N</b>	<b>%</b>
The course draws attention. The interest in the course increased. Being able to address to different senses, and time gain.	9	60	Face-to-face communication falls to the bottom, and by taking advantage of this very situation the students spend most of their time on the mobile tools.	1	6,66
Being able to address to visual and audial senses.	1	6,66			
It removes the restriction of the place. The students can study at home, in the streets and anywhere thanks to the mobile phones. They can easily do the homework with each other from distance students can reach out to learning sources.	2	13,3			
We can have the feedbacks of the students fastly, the long topics are understood well in a relatively short period of time and we can comfortably do the dangerous experiments and studies 3 dimensionally.	1	6,66			
Reaching out the information swiftly, providing the momentary feedback, and productive use an aspect of the paper and time.	1	6,66			
The students' activeness while making the mobile learning.	1	6,66			

When Table 8 is analyzed, 60% of the teachers suggest that “the course draws attention and the interest in the course increased and it is being able to address to different senses, and time gain.” 6.66% say that “being able to address to visual and audial senses” as the positive opinions regarding the mobile learning. As for the negative opinions, they express that “face-to-face communication falls to the bottom, and by taking advantage of this very situation the students spend most of their time on the mobile tools” and “the student’s busyness with the technological tools” seems to be the adverse effects of the wide use of the mobile tools.

### 3.9. What Are the Opinions of the Secondary School Teachers Regarding the Obstacles Encountered in the Integration of the Mobile Learning Tools to the Educational Activities?

The results, shown in Table 9, are prepared in line with the opinions of the secondary school teachers regarding the obstacles encountered in the integration of the mobile learning tools to the educational activities.

Table 9. The opinions of the secondary school teachers regarding the obstacles encountered in the integration of the mobile learning tools to the educational activities.

Technological Information				Pedagogical Information				Content Information				Time Restriction			
		N	%			N	%			N	%			N	%
It is always an obstacle.		1	6,6	It is always an obstacle.		0	0	It is always an obstacle		0	0	It is always an obstacle.		0	0
It is often an obstacle.		2	13,3	It is often an obstacle.		0	0	It is often an obstacle		2	13,3	It is often an obstacle.		2	13,3
It is rarely an obstacle.		4	26,6	It is rarely an obstacle.		8	53,3	It is rarely an obstacle		7	46,6	It is rarely an obstacle.		7	46,6
It is not an obstacle, at all.		8	53,3	It is not an obstacle, at all.		7	46,6	It is not an obstacle, at all.		6	40	It is not an obstacle, at all.		6	40

According to Table 9, when the opinions of the secondary school teachers regarding the obstacles encountered in the integration of the mobile learning tools to the educational activities are analyzed it is stated that the obstacles about “**technological information**” do not most of the time pose impediment. When the proportions are examined, (6,66%) of the participant teachers say that “it is always an obstacle” (13,3%) say that “it is often an obstacle” (26,6%) suggest that “it is rarely an obstacle” and (53,3%) utter that “it is not an obstacle, at all.”

When the opinions of the secondary school teachers regarding the obstacles encountered in the integration of the mobile learning tools to the educational activities are analyzed, the majority of them state that the obstacles about “**pedagogical information**” do not pose an impediment.” When the proportions are examined, (46,6%) of the participant teachers say that “it is not an obstacle, at all” and (53,3%) say that “it is rarely an obstacle.”

When the opinions of the secondary school teachers regarding the obstacles encountered in the integration of the mobile learning tools to the educational activities are analyzed, the majority of them say that the obstacles about “**content information**” do not pose an impediment. When the proportions are examined, (13,3%) of the participant teachers express that “it is often an obstacle”, (40%) of them say that “it is not an obstacle, at all” and (46,6%) suggest that “it is rarely an obstacle.” When the opinions of the secondary school teachers regarding the obstacles encountered in the integration of the mobile learning tools to the educational activities are analyzed, the majority of them



state that the obstacles about “**time restriction**” it is rarely an obstacle. When the proportions are examined, (13,3%) of the participant teachers express that “it is often an obstacle” (40%) suggest that “it is not an obstacle, at all.” and (46,6%) utter that “it is rarely an obstacle.”

### 3.10. What Are the Opinions of the Secondary School Teachers Regarding the Obstacles of the Manager Support, Personal Interest, Vocational Development/Training that the Teachers Encounter in Integration of the Mobile Learning Tools to the Educational Activities?

The results, shown in Table 10, in prepared in line with the opinions of the secondary school teachers regarding the obstacles of the manager support, personal interest, vocational development/training that the teachers encounter in the integration of the mobile learning tools to the educational activities.

Table 10. Technological, pedagogical, content knowledge and time constraint findings

Manager Support	N		%		Personal Interest	N		%		Vocational Development/Training	N		%	
	N	%	N	%		N	%	N	%					
It is always an obstacle	0	0	0	0	It is always an obstacle	0	0	It is always an obstacle	0	0	0	0	0	0
It is often an obstacle	0	0	0	0	It is often an obstacle	2	13,3	It is often an obstacle	0	0	0	0	0	0
It is rarely an obstacle	4	26,6	4	26,6	It is rarely an obstacle	6	40	It is rarely an obstacle	5	33,6	5	33,6	5	33,6
It is not an obstacle	11	73,3	11	73,3	It is not an obstacle	7	46,6	It is not an obstacle	10	66,7	10	66,7	10	66,7

When the opinions of the secondary school teachers regarding the obstacles the teachers encounter in the integration of the mobile learning tools to the educational activities are analyzed, the majority of them claim that the “manager support” is not an obstacle”. When the proportions are examined, (26,6%) of the participant teachers suggest that “it is rarely an obstacle” and the big proportion of them claim (73,3%) claim that “it is not an obstacle, at all.”

When the opinions of the secondary school teachers regarding the obstacles the teachers encounter in the integration of the mobile learning tools to the educational activities are analyzed, the majority of them claim that the “personal interest” “is not an obstacle.” (46,6%) An important proportion (40%) of them claim that “it is rarely an obstacle.”

When the opinions of the secondary school teachers regarding the obstacles the teachers encounter in the integration of the mobile learning tools to the educational activities are analyzed, the majority of them suggest that the “vocational development/training” is rarely an obstacle” and “it is not an obstacle.” When the proportions are examined, (33,6%) of the participant teachers suggest that “it is rarely an obstacle” and (66,7%) claim that “it is not an obstacle.”

### 3.11. What Are the Opinions of the Secondary School Teachers Regarding the Obstacles of the Technological Restrictions, Budget Restrictions that the Teachers Encounter in Integration of the Mobile Learning Tools to the Educational Activities?

The results, shown in Table 11, are prepared in line with the opinions of the secondary school teachers regarding the obstacles of the technological restrictions, the budget restriction that the teachers encounter in the integration of the mobile learning tools to the educational activities.

Table 11. Findings related to manager support, personal interest, professional development / training

<b>Technological Restrictions</b>	<b>N</b>	<b>%</b>	<b>Budget Restrictions</b>	<b>N</b>	<b>%</b>
It is always an obstacle	1	6,6	It is always an obstacle	1	6,66
It is often an obstacle	3	20	It is often an obstacle	2	13,3
It is rarely an obstacle	6	40	It is rarely an obstacle	8	53,3
It is not an obstacle	5	33,3	It is not an obstacle	4	26,6

When the opinions of the secondary school teachers regarding the obstacles the teachers encounter in integration of the mobile learning tools to the educational activities are analyzed, according to Table 11 the majority of them say that the obstacles about **“technological restrictions”** is not an obstacle”, “it is rarely an obstacle” and “it is often an obstacle.” When the proportions are examined, (6,6%) of the participant teachers claim that “it is always an obstacle”, (20%) say that “it is often an obstacle”, (40%) suggest that “it is rarely an obstacle” and (33,3%) utter that “it is no obstacle.”

When the opinions of the secondary school teachers regarding the obstacles the teachers encounter in the integration of the mobile learning tools to the educational activities are analyzed, the majority of the teachers say that the obstacles about **“budget restrictions”** that “it is rarely an obstacle” and “it is not an obstacle.” When the proportions are examined, (26,6%) of the participant teachers express that “it is not an obstacle” while (13,3%) claim that “it is often an obstacle.”

#### 4. Result, Debate, And Suggestions

In this research, it is intended to detect the opinions of the secondary school teachers regarding the use of mobile technologies for educational purposes in the city of Kocaeli and the province of Iand . In general sense, the use of the mobile learning tools in education is assessed positively by the teachers. The finding obtained coincides with Celikten’s (2001) “the big majority of the secondary school administrators and teachers have an assertive attitude towards the use of technology in their management process.” Also, along with technology, it is also significant to observe that the interest and participation of the students increase. In the opinions stated by the teachers, it is underlined that the teachers motivate the students to the courses with the help of the technological tools. These findings resemble that of Gecer and Topal’s (2013). It is seen that the teachers do have a positive attitude towards the mobile learning and they agree with the opinions regarding the effectiveness and advantages of the mobile learning. Yoku1 (2016) supports it as follows; the reason why they have a high level of positive attitude towards the mobile learnings is that they have already been using and downloading the mobile applications for a long period of time.

One of the findings in the conducted research is the answers to the question of which and how mobile tools they use given by the teachers and most of the time they say that “meet the need of the momentary information”, “momentary communication”, and “reflecting the contents on the

smartboard.” It can be said that in the teaching activities it is of high significance that the meeting of the momentary information, to be able to communicate momentarily, and the prepared contents and activities are quite crucial.

In Agn and Bagci’s (2013) study, it is proved that the findings are supported through “the fast accessibility of the information”esbeing able to communicate with one another”, “portability” and that all of these features provide advantages.

In another research conducted by Yang (2012) which supports this finding by stating that “the majority of the students have interests in the mobile tools for the profound learning and that they attend online discussions always and everywhere.”

Among the findings of the research, it is observed that the teachers give more places to visual and audial components in their courses thanks to the mobile tools, and they are now able to use the applications and programs according to the content of the course, the interest of the students in the course increased, it made the students more active in the courses, the learning has become better, the quality of the course rose, and the permanency of the information increased. Chen, Seilhamer, Bennett, and Bauer (2015) have taken the opinions of the students regarding the advantages of the mobile applications and the use of the tools in the study conducted by them for academic purposes.

As a result of the research conducted, %72 of the students say that the mobile application and tools made the accessibility to the class works easier, %65 suggest that it increases the communication with the other students, %60 claim that it increases the communication with the teachers, %48 claim that it increases the information about the working field, %43 of them say that the quality of the study conducted increases, and %42 of them assert that it provided motivation for completing the class works. The participant teachers express that the use of the mobile learning and its tools increases the quality of the quality of the learning. Seferoglu (2009) has the similar finding in his research, as well.

Moreover, in Gecer and Topal’s (2013) study it is suggested that when the students use the technology in their educational peripheries they may encounter with some obstacles such as the network infrastructure incompetence, insufficient software sources, the incompetence of the abilities to reach and interpreting the information. The problems experienced by the teachers regarding their accession to the technological tools may have derived from the school’s technical equipment, the lack of the tool and material in the classroom and the information and skill insufficiency of the teachers for the use of technology. In another study which supports this finding by Kiper (2008) that the problems that the teachers encounter are mainly based on the equipment and even if the equipment is enough but there is no internet connection, the insufficient educational software and the hardships encountered in the classroom management are the main problems that are fixed.

Another finding of the research, just like the majority express, in order to integrate the teachers to the teaching applications and so that the mobile learning, the mobile tools, and the mobile applications could reach the educational targets the most important thing to do is that all the stakeholders, the student, the guardian, the teacher, and the administrator, should orderly have an in-service training and learn how to use the mobile learning fir for its purpose. Seferoglu’s (2009) work supports the similar findings.

Also, Eren and Kurt’s (2011) expression which is that “in presentation of the technology to the individuals the supply and presentation of the education technologies, and solving the problems about the use of technology by orienting and encouraging the teachers to the in-service training about the use of technology” carries the parallelism, as well.

One of the findings of the Fatih Project is that due to the differences among the regions it decreases the inequalities to the least. The students should take advantage of all the facilities without being subject to any kind of discrimination. However, because of the fact that the families’ cultural, socio-economic levels differ from each other, the facilities provided by them also do differ. It can be said that the finding which suggests that it is important from the equal opportunity point of view (Gecer and Topal, 2013) that the students ought to be able to reach the technology and the information any time they need.

One of the findings is that the teachers have declared the negative effects along with the positive ones. These are as follows: it increases the dependence on the mobile tools, it adversely affects the face-to-

face communication, and it accustomed the teachers and the students to the prepared and laziness. In Balko and Saban's (2009) work it is supported by the expression that "the excessive use of the mobile tools make the teachers and the students accustomed to the prepared, it may dwindle their skills of writing and composition, it may cause the unethical learnings, it prevents the living and making learning progress."

It is recommended that it is necessary to strengthen the technical infrastructure and give in-service training chiefly to the students, the teachers, and the administrators as a solution the problems caused by the mobile learning in the students, the teachers, and the administrators. The similar findings are also available in Seferoglu's (2009) works. Also, Akkoyunlu's (1998) work supports this idea by saying that "the educational institutions should use the new technologies, acquire the individuals with the new technologies, and teach them how to use those technologies." The teachers have also expressed that the future of the mobile learning will go in the positive direction in education and it will be used more efficiently in education.

Based on the findings of this study, it is considered that it would be useful to examine the opinions of the students, the guardians, and the teachers regarding the successful integration of the mobile learning in education peripheries.

## 5. Bibliography

- Agca, R.K., Bagci, H. (2013). The Student Opinions Regarding the Use of the Mobile Tools in Education. *Journal of Research in Education and Teaching*, 2(4), 2146-9199.
- Akkoyunlu, B. (1998). The Computer and its Use in Education. *The New Technologies in Contemporary Education* 3(4), 5.
- Arslan, H. (2018). *An Introduction to Education*. London: Cambridge Scholars Publications.
- Balkd, E. ve Saban, A. (2009). The Perceptions and Applications of the Teachers About IT Technologies: The Sample of Private Esentepe Primary School. *Primary Online*, 8(3), 771-781.
- Buyukozturk, S. C S. n, E.K., Akgun, O.E., Karadeniz, S. and Demirel, F. (2009). *Scientific Research Methods*. Ankara: PegemA Publishing.
- Cubslis, M. (2001). "The Problem Solving Skills of the School Administrators" *Education Management Magazine* issue, 27. (297-3009).
- Eren, E. and Kurt, A. (2011). Technological Leadership Conducts of the School Principals. *Usak University Sosyal Social Sciences Magazine*, 4(2), 219-238.
- Gecer, A., Topal, A. D.(2013). *Educational Administration: Theory and Practice 2013*, Vol. 19, Issue 3, pp: 391-417.
- Keegan, D. (2005). "The incorporation of mobile learning into mainstream education and training". In *Proceedings of the 4th World Conference on MLearning (M-Learning: 2005)*, SA, 25-28 October.
- Kiper, A.(2008). *The Use of Educational Technologies on the Courses of the Primary School Teachers and Their Opinions Regarding Their In-Service Trainings*. Gazi University, Educational Sciences Institution. Unpublished Master Thesis, Ankara.
- MEB (2017). <http://www.meb.gov.tr/ogrenci-sayisi-17-milyon-588-bine-yukseldi/haber/10675/tr%20adresinden%2031.01.2017#gsc.tab=0>. Erisim Tarihi 21.12.2017
- Miles, M., & Huberman, A. M. (1994). *Qualitative data analysis: An expanded sourcebook* (2nd ed.). Thousand Oaks, CA: Sage.
- Seferoglu, S. S. (2009). The Use of Technology in the Primary Schools and the Opinions of the Administrators. XI. Academic Information Conferent (AB09) Leaflets. 403-410. Harran University, Sanliurfa. [Online: [http://ab.org.tr/ab09/kitap/seferoglu\\_AB09.pdf](http://ab.org.tr/ab09/kitap/seferoglu_AB09.pdf), Access Date: 24 October 2009.]
- Trifonova, A. (2003). *Mobile Learning: Review Of The Literature*. Technical Report DIT-03- 009, Informatica E-Telecomunicazioni, University Of Trento. Access Date: 20.12.2017 <http://eprints.biblio.unitn.it/archive/00000359/01/009.pdf>
- TUIK, 2016. Access Site: <http://www.tuik.gov.tr/PreHaberBultenleri.do?id=21779>. Access Date: 10.05.2017
- Tsai, C.C. Hsieh W.M.(2017). Taiwanese high school teachers' conceptions of mobile learning. *Computers & Education* 115 (2017) 82-95.

- Yang, S.H. (2012). Exploring college students' attitudes and self-efficacy of mobile learning. The Turkish Online Journal of Educational Technology, 11(4), 148-154.
- Yildirim, A., and Simsek, H. (2006). The Research Methods in Social Sciences (6. bask ) Ankara: Seckin Publishing.
- YokuP, G. (2016). The Examination of the Opinions of the Students of the Faculty of Education on the Mobile Learning and The Study of Developing the Mobile Application Intended for Educational Sciences: Mobile Academy. Unpubslihed Master Thesis, Mersin University Educational Sciences Institution, Mersin.

# Examination Of The Information Literacy Levels Of Health Technicians Students: Aydin Health Services Vocational School Example

Perihan Ogdum, Sevil Ozcan

## 1. Introduction

The information literacy is a skill about finding, reaching, evaluating, using and transmitting of the information in which are different locations and forms. It's a need to be developed of students' literacy levels in academic training process. Because of this necessity, the different level curriculums of information literacy are implemented in universities.

Throughout history we can see that the existing societies have changed from agriculture to industry, and from industry to information society. Industrial society has left agricultural societies behind. After that, a new society that has different technology, economy, social and cultural structure has been created. This new society created and the technology that rapidly changing and evolving have created the need of continuous access to information at the people. Especially computer and internet-based technological changes have increased the need for information, and also they have led the need to quickly obtain information (Akkoyunlu & Kurbanoglu, 2003).

Furthermore this rapidly evolving new system has created changes in every field. The most important of these changes was the definition of literacy. First definition of the literacy was 'The person who knows to read and write his name and who can sign' (Ozbay & Celik, 2013). In a meeting held in November 1951 A committee of experts on standardization of educational statistics, convened by UNESCO and they recommended the following definitions of 'literacy': A person is considered literate who can both read with understanding and write a short, simple statement on his everyday life. The term that has changed over the years has been updated and redefined in accordance with the needs of the age in 1962. And Literacy was defined so, "The person who has the read, write and calculate skills at the level which can contribute to the development of society in which lives, also he or she has acquired the necessary knowledge and skills to effectively perform own duties within the group and community." The definition of "functional literacy" was first put forward at the World Congress of Education Ministers in Tehran in 1965. This concept has also been debated in the following years. In the International Literacy Symposium held in 1975, literacy education was stated that it should be regulated so which provide the individual's development and freedom' (Ozbay & Celik, 2013).

when we came at the present under the influence of all changes and developments, societies have to become a conscious information consumer that have got the knowledge and skills of lifelong learning, constantly can renew and increase their knowledge, can adapt to change, can follow the developments in order to can meet their information needs and keep up with innovations (Akbas & Ozdemir, 2002). Societies need the individuals who can produce information to adapt the changes.

The access to the right information have become an important problem depend on increase the individuals' access to information and multiplication of knowledge, and result of this the lifelong learning concept has been raised. Individuals can develop the ability to reach the right information in every way and to analyze the information that is achieved by moving away from redundant or unnecessary knowledge, thanks to learning and adopting the concept of information literacy. Information literacy which is important for individuals in terms of professional and personal development has become a very important fact for every profession nowadays (Akkoyunlu & Kurbanoglu, 2003). For this reason, the concept of information literacy has become an important element for anyone who successfully fulfils their profession and who wants to reach new knowledge and innovations (developments) in the field of expertise in the globalizing world especially in the health sector first which is showing rapid and constant change.

When information literacy is evaluated in terms of health professionals; we need to have knowledge literacy culture in order to be able to correctly evaluate the information obtained from the different ways of the learners in each field and to process the information correctly. Information literacy can be assessed as a key competence in the provision of adequate services in the future. Information literacy education should be given at all levels of education. Especially healthcare professionals must constantly and quickly take responsibility for renewing themselves. Therefore they face of increased knowledge and constant learning in their personal and professional interests, and to develop this responsibility. Because health is a rapidly changing and developing area (Faydaligul & Colakkol, 2015).

Health is a service sector that requires expert knowledge. This information is valuable to healthcare institutions, patients and the profession. In order to keep this information constantly updated, it is necessary to have a good understanding of the information literacy which is pre-requisite for lifelong learning. Healthcare technicians who have graduated and have took information literacy education will increase productivity in education and practice such as effectively acquire critical thinking, problem solving and decision-making skills. It is desirable of which the health technicians have health knowledge and skills that are needed in almost every step of health care services and in health institutions that serve in different fields who can adapt and use technology that develops at the same time. From this point of view, the health technician should be able to use both the health information and the device and computer applications effectively. Ability to keep up with all these knowledge and skills, to adapt to new applications depend on the ability of individuals to analyze knowledge and to benefit from knowledge. The importance of Technical personnel who are able to use information in their working life and are equipped with information literacy can't be denied to improving the quality of service in health. This study was carried out in order to determine the information literacy levels of the healthcare technicians who have an important place in the health sector and which will provide the connection between the patient and the doctor at different stages.

## 2. Method

This research is a descriptive study based on the survey scanning model. These kinds of models are research approaches that aim to describe a situation which is past or present as it is. The events, individuals or objects that are the subject in a survey is tried to defined in their own conditions and as they are (Karasar, 2012).

The students who were teaching in Medical Documentation and Secretarial (MDS), Medical Laboratory Techniques (MLT), Paramedic (PMD) and Environmental Health (EH) programs of Aydin Health Services Vocational School (AHSVS), Adnan Menderes University (ADU) in 2016-2017 academic year are constitute the sample for this study.

An information instruction and a "Personal Information Form" to identify the characteristics of the students have been added to the initial of the survey. "Information Literacy Scale" developed by Aldemir (2004) and its' reliability coefficient  $\alpha = .94$  was used in order to determine the opinions of medical technician candidates regarding information literacy situations. The survey was a 5-point Likert-type scale (1- I have great difficulty, 2- I have difficulty . 3- Uncertain, 4- I haven't got difficulty, 5- I haven't got any difficulty), and it was consist of 35 items. The data obtained from the scale were converted to a 3-scale and then evaluated in the SPSS program. The personal information form and information literacy scale were applied to the volunteer students at the same time by the researcher. There was no time limitation when the students were filling the survey.

The data were analyzed with IBM SPSS Statistics 21 program. When the evaluation of the study data, descriptive statistical methods (mean, standard deviation, frequency) as well as chi-square and T-test were used in comparison of two groups of quantitative data, and the results were evaluated at 95% confidence interval and  $p < 0.05$ .

## 3. Findings

Demographic features of the participants like below: Total 246 health technician candidates participated to the study, and 155 (63%) of participants were female and 91 (37%) of them were male.

## Examination Of The Information Literacy Levels Of Health Technicians Students

175 (71.1%) of them 1<sup>st</sup> grade, 71 (28.9%) of them were 2<sup>nd</sup> grade. Age groups were 17-20 (n:173, 70.3%), 21-23 (n:61, 24.8%), 24 and over (n:12, 4.9%). 180 (73.2%) of candidate technicians were the students in day time learning and 66 (26.8%) of them night learning students. Distribution of them according to their education program were PMT (n:96, 39%), EH (n:24, 9.8%), MLT (n:39, 15.8%) and MDS (n:87, 35.4%).

**Table 1.** Statistical data related to student responses to scale expressions (f, %, mean, p and differencies with chi-square).

	Difficulty N (%)	Undecide N (%)	Not difficulty N (%)	Mean	P	Differences (Grade=1-2 Age groups are 17-20=I 21-23=II 24+=III Gender=F- M)
<b>1. In the situation when I have to identify the homework / research topic myself, I have .....</b>	58 (23.6)	57 (23.2)	131 (53.3)	2.29	0.1	
<b>2. I have ..... to defining that my information requirement related to the homework / research topic.</b>	47 (19.1)	59 (24.0)	140 (56.9)	2.37		
<b>3. I have ..... expanding and narrowing the homework / research topic</b>	45 (18.3)	78 (31.7)	123 (50.0)	2.31	0.5	
<b>4. I have ..... to how and where find the information that I need.</b>	33 (13.4)	46 (18.7)	167 (67.9)	2.54	0.04	2<1
<b>5. In information search, I have ..... to identify the words that are the best describe the topic (keywords).</b>	41 (16.7)	66 (26.8)	139 (56.5)	2.39	0.1	
<b>6. I have .... to decision about which kind of information resource is more appropriate for which kind of information requirement.</b>	27 (11.0)	74 (30.1)	145 (58.9)	2.47	0.00	2<1
<b>7. I have ..... to using of different type information resources (encyclopedia, journal, guide, annual, etc.)</b>	33 (13.4)	47 (19.1)	166 (67.5)	2.54	0.6	
<b>8. I have ..... to using web resources (information resources on the web, web pages, e-journals, encyclopedias, etc.).</b>	17 (6.9)	32 (13.0)	197 (80.1)	2.73	0.00	M<F III>I and II
<b>9. I have .... to choosing and using of the indexes and e-database that are providing access to the information.</b>	35 (14.2)	63 (25.6)	148 (60.2)	2.45	0.1	
<b>10. I have ..... to using web search engine.</b>	12 (4.9)	32 (13.0)	202 (82.1)	2.77	0.00	M<F III>I and II
<b>11. I have .... to understand and apply of the router information at electronic information access systems (database, search engines, etc.)</b>	27 (11.0)	59 (24.0)	160 (65.0)	2.54	0.07	



<b>12. I have ... to do limitation such as date, language and kind. While I was searching information on computer.</b>	19 (7.7)	63 (25.6)	164 (66.7)	2.58	0.6	
<b>13. I have .... to define the relation between concepts using the conjunctions (and, or, not). While I was searching information on computer.</b>	36 (14.6)	50 (20.3)	160 (65.0)	2.50	0.7	
<b>14. I have ..... to try different search approaches. If I fail when searching for information.</b>	25 (10.2)	54 (22.0)	167 (67.9)	2.57	0.3	
<b>15. I have .... to using the library catalogue.</b>	54 (22.0)	66 (26.8)	126 (51.2)	2.29	0.8	
<b>16. I have .... to understand the information that are related to sources on catalogue.</b>	32 (13.0)	65 (26.4)	149 (60.6)	2.47	0.0 1	I and III < II
<b>17. I have .... using the other libraries.</b>	54 (22.0)	64 (26.0)	128 (52.0)	2.30	0.3	
<b>18. I have ..... to evaluation in terms of the quality and quantity of the obtained information to the topic.</b>	31 (12.6)	53 (21.5)	162 (65.9)	2.53	0.9	
<b>19. I have ... to evaluate the information obtained in terms of factors such as topicality, reliability, accuracy, and impartiality.</b>	31 (12.6)	64 (26.0)	151 (61.4)	2.48	0.0 0	M<F II>I and III
<b>20. I have ... to evaluate the web resources in terms of factors such as topicality, reliability, accuracy, and impartiality.</b>	26 (10.6)	71 (28.9)	149 (60.6)	2.50	0.0 4	I and II < III
<b>21. I have ... to determine the basic idea after read the information resource obtained.</b>	22 (8.9)	65 (26.4)	159 (64.6)	2.55	0.4	
<b>22. I have ... to determine the same and different points between the information resources I have read.</b>	23 (9.3)	66 (28.6)	157 (63.8)	2.54	0.0 2	M<F
<b>23. I have ... to interpret the information I have obtained.</b>	28 (11.4)	53 (21.5)	65 (67.1)	2.55	0.4	
<b>24. I have .... to associate the information I got before with I have obtained new.</b>	18 (7.3)	66 (26.8)	162 (65.9)	2.58	0.3	
<b>25. I have .... to re-express the information obtained from the sources with my own words.</b>	36 (14.6)	65 (26.4)	145 (58.9)	2.44	0.5	
<b>26. I have .... to using together many resources, while I am doing homework/research.</b>	22 (8.9)	72 (29.3)	152 (61.8)	2.52	0.2	
<b>27. I have .... to organize sections of the assignment (cover, contents, introduction, development, bibliography, attachments, etc.).</b>	26 (10.6)	48 (19.5)	172 (69.9)	2.38	0.0 0	M<F

## Examination Of The Information Literacy Levels Of Health Technicians Students

<b>28. I have .... to show which information is taken from within the assignment (reference in the text such as reference / citation, quotation).</b>	25 (10.2 )	66 (26.8 )	155 (63.0)	2.52	0.2	
<b>29. I have ..... to preparing a list of sources (books, journals, web pages, etc.) that I use in my homework / research.</b>	28 (11.4 )	47 (19.1 )	171 (69.5)	2.58	0.0 0	M<F
<b>30. I have ..... to orally presentation to the homework/ research's results.</b>	47 (19.1 )	71 (28.9 )	128 (52.0)	2.32	0.8	
<b>31. I have ..... to writiten presentation to the homework/ research's results.</b>	30 (12.2 )	50 (20.3 )	166 (67.5)	2.55	0.0 3	M<F
<b>32. I have ..... to comply with the limitation such as number of pages and time in the presentation of information.</b>	27 (11.0 )	67 (27.0 )	152 (61.8)	2.50	0.7	
<b>33. I have ..... to use appropriate technology in the transmission / presentation of information (PowerPoint slides, video, word file, etc.).</b>	22 (8.9)	55 (22.4)	169 (69.7)	2.59	0.6	
<b>34. I have ..... to criticizing homework / research I've done (identifying strengths and weaknesses).</b>	32 (13.0 )	63 (25.6 )	151 (61.4)	2.48	0.7	
<b>35. I have .... to use my past activities related to information in the future (search, find, use and transmit of the information).</b>	18 (7.3)	61 (24.8)	167 (67.9)	2.60	0.5	

When the data are examined it was seem that the most challenging topics for healthcare technician's students were 1<sup>st</sup>, 15<sup>th</sup>, and 17<sup>th</sup> expressions. We have concluded that from these expressions, it was that they were having difficulty to determine their own research / homework issues and working in the library (23.6%, 22.0% and 22.0%).

The least difficult topics for them were 10<sup>th</sup> and 8<sup>th</sup> expressions. According to these results, health technician candidates stated that they were not having difficulty using Web resources and search engines (82.1% and 80.1%).

The most undecided expressions of students were the 3<sup>rd</sup> and 6<sup>th</sup> phrases that they did not confident about their level of knowledge and skill in these topics (**31.7% and 30.1%**). As to this results it can be said that they did not trust themselves about exceed/limitation of knowledge related to homework/research and did not sure which kind of information can be found in which information recourses.

The answers were assessed by chi-square test to determine whether there was a significant difference in demographic characteristics (gender, class, age and curriculum).

According to this, 8<sup>th</sup>, 10<sup>th</sup>, 19<sup>th</sup>, 22<sup>th</sup>, 27<sup>th</sup>, 29<sup>th</sup> and 31<sup>st</sup> depending on the gender were determined statistically significant differences in the expressions (table 1). Meaningful differences, depending on the grade level, were found in responses given to the 4<sup>th</sup> and 6<sup>th</sup> expressions (table 1). It was determined that health technician candidates had a statistically significant difference in answers given to questions 8, 10, 13, 19 and 20 as a result of chi-square analysis based on age group (table 1). There is no statistically significant difference between answers given to any scale expression, depending on the program they have educated.

#### 4. Results and Discussion

The vast majority of our samples were young people in the 17-20 age range. Typical problems of young people who were born to the world in the electronic development age are lack of ability to think critically, not to comment and to act with commands only, etc. As a result of this scaled study done, it was seen that the students of health technicians stated that they did not have self-confident,

even they had worry in make decision and making research using with written sources in library. Same results have been faced in Demir & Seferoglu's (2016) paper. Faydaligul and Colakkol (2015) reported that individuals of the electronic knowledge age use the easiest to web based information searching systems. In our study, it was seen web based searching engines were used by health technicians candidates had not difficulties too, when their answers of the expressions 8<sup>th</sup> and 10<sup>th</sup> had been evaluated (80.1%, 82.1%).

It can be said that the students participated to the survey were lacking knowledge and skills in library and catalog screening, and also utilization skills of different library resources. Because when students' answer given to 15 and 17 expressions were evaluated to that was reached to the result that they have difficulty to use the library. Similarly, Ozbay and Celik (2013) reported a decrease in the students' tendency to use the library.

When the answers given to the scale expressions were analyzed according to gender these result have been found that the female students were having less difficult than the male students about below topics:

- Using of web resources (information resources on the web, web pages, electronic magazines, encyclopaedias, etc.),

- Using of web search engines,

- Evaluate of the information obtained in terms of factors such as updating, reliability, accuracy, and impartiality,

- To identify the similar and different points between the sources of the information read,

- To organize the homework's sections (cover, contents, introduction, development, bibliography, attachments, etc.),

- I am preparing a list of the different sources (books, journals, web pages, etc.) I use in my homework / research (bibliographic information),

- Present the results of the research in writing (homework, reports, articles, etc.),

It has been determined that have significantly less difficulty 1st grade students than 2nd grade students related to 4th and 6th express. We think this result may have arisen due to the fact that they have not yet been exposing to situations such as homework, project and research report preparation in their training process.

It can be an important problem that not adequate orientation about information resources to students. Thus they were having difficulty in determining the homework issues and using the information resources. Because the students who can't reach to the result in research and homework can leave undone their studies due to have difficulties in accessing the information. As a result, in the creation of the information society, which is a sign of the level of development, it is necessary that acquire knowledge literacy skills have been gained to individuals (Altay, Demirel & Topbasli, 2017; Kurbanoglu, 2010).

Higher education is the final phase of the individuals' training process. So knowledge literacy skill should be got to them in this period for complete and actively contribute to their daily and working lives. The fact that every student who graduates from universities has knowledge literacy skills will contribute to the level of development of countries.

## 5. Conclusions

These kinds of courses should be taken compulsory and/or elective courses by students in order to gain knowledge literacy skills. At the same time it is possible to increase their skills in this topic thanks to homework, project etc. studies. Furthermore, when evaluated the students' studies the lecturers make criticizing evaluations, and correct orientation should be raised important results and differences on students' development. Furthermore, when evaluated the students' studies the lecturers make criticizing evaluations, and correct orientation should be raised important results and differences on students' development.

## 6. References

- Akbas, O., & Ozdemir, S. M. (2002). Avrupa Birliğinde yaşam boyu öğrenme. *Milli Eğitim Dergisi*, 155(156), 112-126.
- Akkoyunlu, B. & Kurbanoglu, S. (2003). Öğretmen Adaylarının Bilgi Okuryazarlığı ve Bilgisayar Öz-Yeterlik Algıları Üzerine Bir Çalışma [A Study on Teacher Candidates' Perceived Information Literacy Self-efficacy and Perceived computer Self-efficiency]. Hacettepe Üniversitesi Eğitim Fakültesi Dergisi [Journal of Hacettepe University Education Faculty], 24, 1-10.
- Aldemir, A. (2003). Bilgiye Erisimde Yeni Yaklaşım: Bilgi Okuryazarlığı, II. Tıbbi Bilgi Yönetimi ve Teknolojileri Sempozyumu. Ed. Aytac Yıldızeli, Canan Duran, Hatice Kubra Bahsisoğlu. Ankara, Retrieved at January 21, 2018, from <http://kaynak.unak.org.tr/bildiri/unak03/u03-29.pdf>
- Altay, A., Demirel, C. & Topbaşlı, B., (2017). "Kırklareli Üniversitesi Pınarhisar Meslek Yüksekokulu Bilgi Yönetimi Programı Öğrencilerinin Bilgi Okuryazarlığı Becerilerinin Değerlendirilmesi" UMYOS, 18-20 Mayıs
- ACRL (Association College and Research Libraries) CHICAGO. (2000). *Libraries information Literacy Standards for Higher Education* Retrieved at January 21, 2018, from <http://www.ala.org/acrl/sites/ala.org/acrl/files/content/standards/standards.pdf>
- Demir, O. & Seferoğlu, S. (2016). The Investigation of the Relationship of Cyber Bullying with Cyber Loafing, Internet Addiction, Information Literacy and Various Other Variables. Online Journal Of Technology Addiction & Cyberbullying, 3 (1), 1-26. Retrieved from <http://dergipark.gov.tr/ojtac/issue/24675/260969>
- Faydalıgul O.D. & Colakkol, A. (2015). Hemsirelik Öğrencilerinde Bilgi Okuryazarlığı Eğitimi Retrieved at January 21, 2018, from <http://ab.org.tr/ab16/bildiri/137.pdf>
- Henkoglu, H. S., Mahiroglu, A. & Keser, H. (2015). Ortaokul Öğrencilerinin Bilgiye Erisim Aracı Olarak İnternete Yaklaşımları: Betimleyici Bir Çalışma [Approaches of Middle School Students to Internet as an Information Access Tool: A Descriptive Study]. Turkish Online Journal of Qualitative Inquiry, January, 6(1), <http://dx.doi.org/10.17569/tojqi.01897>
- Karasar, N. (2012). Bilimsel araştırma yöntemi. Ankara: Nobel Yayınları p.59.
- Kurbanoglu, S. (2010). Bilgi okuryazarlığı: kavramsal bir analiz, [Information Literacy: A Conceptual Analysis] *Türk Kutuphaneciliği*, [Turkish Librarianship], 24 (4), 723-747.
- Ozbay, M. & Celik, M. E. (2013). Türkçe öğretmeni adaylarının bilgi okuryazarlık düzeylerinin incelenmesi. [Review of Information Literacy Levels of Turkish Candidate Teachers] Ana Dili Eğitimi Dergisi [Journal of Mother Tongue Education] 1(4), 10-21.
- UNESCO (1951). *Defining of "the knowledge literacy"* Retrieved at February 20, 2018, from <http://www.unesco.org/education/educprog/50y/brochure/tle/122.htm>



# **Associate Degree Students' Self-Efficacy Beliefs about English Language Proficiency: The Department of Hotel, Restaurant and Catering Services at Davutlar Vocational School**

Bilge Sevim Okuyan, Ahu Sezgin, Emrah Koksak Sezgin

## **1. Introduction**

The concept of self-efficacy is often considered an educational term and used in education-related research. Self-efficacy particularly appears in studies where social cognitive theory is analyzed and applied. First in-depth analysis of self-efficacy construct is attributed to Albert Bandura. As a professor of psychology, Bandura (1977) presents self-efficacy in a psychological context and evaluates its influence, as “a common cognitive mechanism,” on changing “fearful and avoidant behavior.” Bandura (1977) defines self-efficacy as “the conviction that one can successfully execute the behavior required to produce the outcomes.” He later uses self-efficacy as a major component of social learning theory, which develops mainly as a result of Bandura’s studies in the second half of the 1960s and as a reaction to behaviorist learning theory which exclusively maintained the principle of external stimuli in learning. Making self-constructs and self-processes the focal point, Bandura (1982) firmly advocates that individuals can control their thought, emotions, and actions to a certain extent as proactive and self-regulating social beings. He further states that the influence of self-efficacy on “how much effort [individuals] put forth” and “how long they will persevere in the face of obstacles and failures” is stronger than all other self-referential constructs (1997). In this view, self-efficacy beliefs, i.e. the beliefs that individuals hold about their capabilities, can predict their agency and performance.

Bandura’s definitions and statements about self-efficacy beliefs are directly linked to learning and teaching process, so the suggested influence of self-efficacy beliefs on educational issues, such as performance and motivation of students and teachers, has galvanized interest and research. While most studies establish that students’ self-efficacy beliefs can predict their academic performance (Bandura, 1984; Pintrich & de Groot, 1990; Pajares & Miller, 1994; Pajares & Kranzler, 1995; Zimmerman, 1999), more recent studies focus on teachers’ self-efficacy beliefs about their profession and how self-efficacy can influence various issues such as job satisfaction, motivation, and burnout (Ashton, 1984; Skaalvik & Skaalvik, 2007; Skaalvik & Skaalvik, 2010).

Also, a large body of research at the end of 2000s and the beginning of 2010s explores how self-efficacy, as a predicting variable, affects learning foreign/second language skills, performing tasks, and language acquisition (Mahyuddin, et al., 2006; Hsieh & Schallert 2008; Rahimi & Abedini, 2009; Tilfarlioglu & Ciftci, 2011; Moghari et al., 2011; Yilmaz, 2010; Wang & Li, 2010; Shang, 2010; Hsieh & Khang, 2010). Similar studies about the predictors of achievement in foreign/second language learning show that self-efficacy is the strongest variable in predicting achievement in foreign/second language learning (Hsieh & Schallert, 2008; Wang, Spencer & Xing, 2009; Mills, Pajares, & Herron, 2007).

In 2016 Genc, Kulusakli, and Aydin conducted a study with the participation of 210 university students studying English language teaching. This study aimed at evaluating the role of self-efficacy in acquiring the skills of reading, writing, listening, and speaking in English. The findings revealed that students with stronger self-efficacy beliefs had a positive attitude towards language learning and experienced lower levels of learning anxiety.

## **2. The Aim and Significance of the Study**

This study aims at investigating associate degree students’ levels of self-efficacy beliefs about English language proficiency. The participants were selected among the first and second-year students who

studied at the Department of Hotel, Restaurant, and Catering Services at Davutlar Vocational School. The sub-problems of the study are as follows:

1. What are associate degree students' self-efficacy beliefs about reading, writing, listening, and speaking in English?
2. Is there a significant difference among associate degree students' self-efficacy beliefs in terms of gender, age, weekly study hours spent for English, their field of study, or out-of-school resources such as tutoring or private language schools?

### **3. Method**

After reviewing the literature on self-efficacy and English proficiency, a number of questionnaires were selected to create questionnaire statements to be used in this study. The participants were asked to choose the best option on the Likert scale starting with "1: Strongly disagree" and ending with "5: Strongly agree."

After the reliability analysis on SPSS, the data was evaluated in terms of significant difference. If the difference was between two groups, unpaired t-test was used. If the difference was among different groups, one-way analysis of variance (ANOVA) was used.

#### **3.1. Population and Sample**

The population of the research is the students studying at the departments of hotel, restaurant, and catering services. The sample was drawn from 425 students studying culinary arts, catering services, and tourism management at the Department of Hotel, Restaurant, and Catering Services at Davutlar Vocational School during the academic year of 2017-2018. As the target population was inaccessible due to time restriction and possible expenses, the sample was drawn by means of convenience sampling method. The number of respondents is 203.

#### **3.2. Data Collection Tool, Validity, Reliability**

The data was collected by means of "Self-Efficacy Beliefs for English Scale" developed by Yanar and Bumen in 2012. The scale has four sub-dimensions and 34 items. Reading dimension has 8 items; writing dimension has 10 items; listening dimension has 10 items; speaking dimension has 6 items. The factor loading values of the items vary between 0.42 and 0.69. The Cronbach Alpha internal consistency coefficient of the scale was 0.97 (Yanar and Bumen, 2012). The data collection tool was designed as five-point Likert Scale. The pre-coded responses were "I strongly disagree", "I disagree", "Neutral", "I agree", "I strongly agree." Respondents could obtain maximum 240 points from each sub-dimension. The data obtained from the second scale was added to the other variables. The findings proved both scales to be valid and reliable.

### **4. Findings**

The findings presented below have revealed students' the self-efficacy beliefs about reading, writing, listening, and speaking in English with reference to the variables of gender, age, weekly study hours spent for English, their field of study, or out-of-school resources such as tutoring or private language schools.

**Table 1. Frequency Distribution of Students at the Department of Hotel, Restaurant, and Catering Services**

<b>Gender</b>	<b>Frequency</b>	<b>Percentage</b>
Female	89	43,8
Male	114	56,2
Total	203	100
<b>Age</b>	<b>Frequency</b>	<b>Percentage</b>
18-19	114	56,2
20-21	27	13,3
22-23	43	21,2
24 and above	19	9,4
Total	203	100
<b>Field of study</b>	<b>Frequency</b>	<b>Percentage</b>
Tourism and Hotel Management	74	36,5
Culinary Arts	53	26,1
Catering Services	76	37,4
Total	203	100
<b>Weekly study hours</b>	<b>Frequency</b>	<b>Percentage</b>
None	50	26,6
1-2 hours	128	63,1
3-4 hours	22	10,8
5-6 hours	3	1,5
Toplam	203	100
<b>External resources (e.g. tutoring)</b>	<b>Frequency</b>	<b>Percentage</b>
Yes	58	26,8
No	145	71,4
Total	203	100

The frequency distribution in Table 1 shows that 43% of the participants are female and 56.2% are male; 56.2 % are at the age range of 18-19. 37.4% study catering services while 36.5% study tourism and hotel management and 26.1% culinary arts. 63.1% of the participants spend 1-2 hours in a week for studying English, 10.8% spend 3-4 hours, and 1.5% spends 5 or 6 hours. 26.6% percent of the participants spend no weekly study time for English. 71.4% of the participants do not turn to out-of-school resources for learning English, whereas 26.8% percent have resorted to these resources.

#### **4.1. Normal Distribution Analyses**

Normal distribution analyses of Self-Efficacy Beliefs for English Scale show that the mean is 2.69, median value is 2.69; and the range is 5,04. The values for skewness and kurtosis are between -2 and +2. The data are considered acceptable for normal distribution (George & Meallery, 2010).



**Table 2. Is there a significant difference among students' self-efficacy beliefs about English in terms of gender?**

Gender		N	X	Std dev	df	t	p
Reading	Female	89	2,6826	,71981	201	-2,325	,021
	Male	114	2,9529	,89328			
Writing	Female	89	2,4393	,75447	201	-1,736	,034
	Male	114	2,6640	1,02293			
Listening	Female	89	2,6697	,79221	201	-3,296	,001
	Male	114	3,0635	,88345			
Speaking	Female	89	2,1854	,83312	201	-4,44	,000
	Male	114	2,7412	,92334			

According to unpaired t test results, there is a significant difference between the self-efficacy belief scores of female and male participants. For instance, the mean of self-efficacy beliefs about reading scores of female participants is 2.68 (std dev ,719) whereas that of male participants is 2.95 (std dev ,893). This comparison shows that the male participants' self-efficacy scores differ more significantly. The same difference is true for writing, listening, and speaking ( $p < 0,05$ ).

**Table 3. Is there a relationship between students' self-efficacy beliefs about English and their age?**

		Sum Squares	df	Mean Square	F	Sig.
Reading	Between Groups	3,280	3	1,093	1,598	,191
	Within Groups	136,135	199	,684		
	Total	139,415	202			
Writing	Between Groups	3,878	3	1,293	1,541	,205
	Within Groups	166,980	199	,839		
	Total	170,859	202			
Listening	Between Groups	1,251	3	,417	,554	,646
	Within Groups	149,922	199	,753		
	Total	151,174	202			
Speaking	Between Groups	1,508	3	,503	,584	,626
	Within Groups	171,352	199	,861		
	Total	172,860	202			

ANOVA results show that there is no significant relationship between students' self-efficacy beliefs about reading ( $F: 1,59$ ;  $p > 0,05$ ), writing ( $F: 1,54$ ;  $p > 0,05$ ), listening ( $F: ,554$ ;  $p > 0,05$ ), and speaking ( $F: ,584$ ;  $p > 0,05$ ) in English and their age.

**Table 4. Is there a relationship between students' self-efficacy beliefs about English and their field of study?**

		Sum of Squares	df	Mean Square	F	Sig.
Reading	Between Groups	2,878	2	1,439	2,108	,124
	Within Groups	136,537	200	,683		
	Total	139,415	202			
Writing	Between Groups	,539	2	,269	,316	,279
	Within Groups	170,320	200	,852		
	Total	170,859	202			
Listening	Between Groups	5,989	2	2,995	4,125	,018
	Within Groups	145,184	200	,726		
	Total	151,174	202			
Writing	Between Groups	4,153	2	2,076	2,461	,038
	Within Groups	168,707	200	,844		
	Total	172,860	202			

ANOVA results show that there is no significant relationship between students' self-efficacy beliefs about reading (F: 2,108;  $p>0,05$ ) and writing (F: ,316;  $p>0,05$ ) in English and their field of study. However, there is a significant relationship between self-efficacy beliefs about listening (F: 4,12;  $p<0,05$ ) and speaking (F: 2,46;  $p<0,05$ ) and the participants' field of study. The program of tourism and hotel management has the highest mean (listening: 3.11, speaking: 2.67) among the groups. The lowest mean belongs to the program of catering services (listening: 2.27, speaking: 2.34).

**Table 5. Is there a relationship between students' self-efficacy beliefs about English and the weekly study hours they spend for English?**

		Sum of Squares	df	Mean Square	F	Sig.
Reading	Between Groups	5,301	3	1,767	2,622	,050
	Within Groups	134,114	199	,674		
	Total	139,415	202			
Writing	Between Groups	32,562	3	10,854	15,618	,000
	Within Groups	138,296	199	,695		
	Total	170,859	202			
Listening	Between Groups	11,488	3	3,829	5,455	,001
	Within Groups	139,686	199	,702		
	Total	151,174	202			
Writing	Between Groups	11,450	3	3,817	4,706	,003
	Within Groups	161,410	199	,811		
	Total	172,860	202			

ANOVA results show that there is a significant relationship between students' self-efficacy beliefs about reading (F:2,622;  $p<0,05$ ), writing (F:15,6;  $p<0,05$ ), listening (F:5,4;  $p<0,05$ ), and speaking (F:4,7;  $p<0,05$ ) in English and weekly study hours they spend for studying English. The most significant difference is between the group which selected "5-6 hours" and the one which selected "None."

**Table 6. The Relationship between the Participants' Self-Efficacy Belief Scores and the Out-of-school Resources They Use for Learning English**

Extra resources for English		N	X	ss	df	t	p
Reading	Evet	58	3,2392	,92873	201		
	Hayir	145	2,6724	,73096			
Writing	Evet	58	3,0069	1,19925	201	4,509	,000
	Hayir	145	2,3890	,71230			
Listening	Evet	58	3,3431	,93285	201	4,981	,000
	Hayir	145	2,7099	,76812			
Speaking	Evet	58	2,9138	,96187	201	4,220	,000
	Hayir	145	2,3310	,85819			

According to unpaired t test results, there is a significant difference between the self-efficacy belief scores of those who use out-of-school learning resources and those of who do not use these resources. The most significant difference between two groups is seen at the self-efficacy belief scores for reading. The scores differ significantly between two groups in terms of writing, listening, and speaking as well ( $p < 0,05$ ).

## 5. Conclusion and Discussion

In this study, which aims at finding out about associate degree students' self-efficacy beliefs about English proficiency, the participants were the students at the Department of Hotel, Restaurant and Catering Services at Davutlar Vocational School. Although the numbers of female and male participants are close to each other, their self-efficacy belief scores differ significantly in terms of gender. Male participants' self-efficacy scores for reading in English show more significance. The other three language skills also differ significantly between male and female participants. Similar findings can be seen in a study by Gomleksiz and Kilinc (2014). The mean of self-efficacy belief scores of male participants for reading, writing, listening, and speaking skills is higher. According to Gomleksiz and Kilinc, the reason for this significant difference could be that parents favor boys over girls in Turkish society. Therefore, boys can develop stronger self-efficacy beliefs. On the other hand, Ocak and Baysal (2016) conduct research with high school students to investigate their self-efficacy beliefs about English and the female respondents in this study scored higher in reading, writing, listening, and speaking.

ANOVA results in this study show that there is no significant relationship between students' self-efficacy beliefs about reading, writing, listening, and speaking in English and their age. A study by Ocak and Hocaoglu (2015) presents a different finding: there is a significant relationship between undergraduate degree students' self-efficacy beliefs about English and age. Ocak and Hocaoglu conclude that as undergraduate students get older, they scored higher in self-efficacy scale. As our study deals with the self-efficacy beliefs of associate degree students, it is assumed that the reason for the insignificant relationship between self-efficacy and age is due to the short period of time these students spend at school. Associate degree students in Turkey receive two years of college education and they leave school before they can fully grasp their potential of learning a foreign/second language, whereas undergraduate students stay for four years, or sometimes longer, at school and they probably realize both their own potentials and the importance of English.

Another finding in this study shows that there is no significant relationship between participants' self-efficacy beliefs about reading and writing in English and their field of study. There is, however, a significant relation between listening and speaking in English and their field of study. The program of tourism and hotel management has highest mean (listening: 3.11, speaking: 2.67) among the groups. The lowest mean belongs to the program of catering services (listening: 2.27, speaking: 2.34). This difference is thought to be due to the attitude the tourism students adopt towards the tourism industry.

Tourism and hotel management graduates generally work at hotels and restaurants where they can have face-to-face communication with guests. It is assumed that their possible working environment affects both their attitude towards English language and their self-efficacy beliefs about listening and speaking in English. Culinary arts and catering services students, on the other hand, usually find positions in the kitchen where face-to-face communication with guests is almost non-existent. Therefore, they might have weaker self-efficacy beliefs resulting from their working environment and their attitude towards English. A study by Okuyan and Sezgin (2017) conducted with associate degree students studying culinary arts presents supporting results. Culinary arts students have stated they consider their English skills insufficient.

Study findings also show that there is a significant relationship between students' self-efficacy beliefs about reading, writing, listening, and speaking in English and weekly study hours they spend for studying English. Gomleksiz and Kilinc (2014) present a similar finding in their research conducted with high school students. Therefore, it is thought weekly study hours for English have a direct influence on self-efficacy beliefs about English.

There is a statistically significant difference between the self-efficacy scores of participants who resort to tutoring or private language schools for supporting their English learning process and those of who do not use any supporting resources. For example, self-efficacy scores for reading differ significantly between the ones who use out-of-school learning support and those who do not. The same is true for writing, listening, and speaking in English. Matthews (2010) suggests that short and concentrated tutoring sessions for English have a positive motivational effect on self-efficacy beliefs of college students. This finding Matthews presents is consistent with the one presented in our study. It can be inferred that English lessons in higher education institutions may be insufficient in promoting student self-efficacy in English proficiency.

## 6. References

- Ashton, P. (1984). Teacher efficacy: A motivational paradigm for effective teacher education. *Journal of Teacher Education*, 35 (5), 28-32.
- Bandura, A. (1977). Self-efficacy: Toward a unifying theory of behavioral change. *Psychological Review*, 84, 191-215.
- Bandura, A. (1982). Self-efficacy mechanism in human agency. *American Psychologist*, 37 (2), 122-147.
- Bandura, A. (1984). Recycling misconceptions of perceived self-efficacy. *Cognitive Therapy and Research*, 8 (3), 231-255.
- Bandura, A. (1997). *Self-efficacy: The exercise of control*. New York, NY: W. H. Freeman & Co, Publishers.
- Genc, G., Kulusakli, E., Aydin, S. (2016). Exploring EFL learners perceived self-efficacy and beliefs on English language learning. *The Australian Journal of Teacher Education*, 40 (2).
- George, D., Mallery, M., (2010). *Using SPSS for Windows step by step: A simple guide and reference*. Boston, MA: Allyn & Bacon.
- Gomleksiz, M. N., Kilinc, H. H. (2014). High school 12th grade students' perceptions of self-efficacy beliefs for English. *Firat University Journal of Social Science*, 24 (2), 43-60.
- Hsieh, P. P., & Kang, H. S. (2010). Attribution and self-efficacy and their interrelationship in the Korean EFL context. *Language Learning*, 60 (3), 606-627.
- Hsieh, P. H. P., & Schallert, D. L. (2008). Implications from self-efficacy and attribution theories for an understanding of undergraduates' motivation in a foreign language course. *Contemporary Educational Psychology*, 33, 513-532.
- Mahyuddin, R., Elias, H., Cheong, L. S., Muhamad, M. F., Noordin, N., & Abdullah, M. C. (2006). The relationship between students' self-efficacy and their English language achievement. *Jurnal Pendidik dan Pendidikan*, 21, 61-71.
- Matthews, P. H. (2010). Factors influencing self-efficacy judgments of university students in foreign language tutoring. *The Modern Language Journal*, 94 (4), 618-635.
- Mills, N., Pajares, F., & Herron, C. (2007). Self-efficacy of college intermediate French students:

- Relation to achievement and motivation. *Language Learning*, 57 (3), 417–442.
- Moghari, E. H., Lavasani, M. G., Bagherian, V., & Afshari, J. (2011). Relationship between perceived teacher's academic optimism and English achievement: Role of self-efficacy. *Procedia Social and Behavioral Sciences*, 15, 2329–2333.
- Pajares, F. M., Miller, M. D. (1994). Role of self-efficacy and self-concept beliefs in mathematical problem solving: A path analysis. *Journal of Educational Psychology*, 86 (2), 193-203.
- Pajares, F. M., Kranzler, J. (1995). Self-efficacy beliefs and general mental ability in mathematical problem-solving. *Contemporary Educational Psychology*, 20 (4), 426-443.
- Pintrich, P. R., de Groot, E. V. (1990). Motivational and self-regulated learning components of classroom academic performance. *Journal of Educational Psychology*, 82 (1), 33-40.
- Ocak, G., Hocaoglu, N. (2015). The investigation of attitudes towards English lesson in terms of self-efficacy beliefs and some variables. *KKEFD*, 31, 37-61.
- Ocak, G., Baysal E. A. (2016). The examination of students' language learning strategies and their self-efficacy beliefs: the sample of Afyonkarahisar. *Marmara University Journal of Educational Sciences*, 44, 91-110.
- Okuyan, B., Sezgin, A. (2017). Vocational school culinary arts program students' opinions on English for occupational purposes (EOP) courses. *Proceedings of UMYOS 2017: 6th International Vocational Schools Symposium* (pp. 49-55). Bosnia & Herzegovina.
- Rahimi, A., Abedini, A. (2009). The interface between EFL learners' self-efficacy concerning listening comprehension and listening proficiency. *Novitas-ROYAL*, 3 (1), 14-28.
- Shang, H. F. (2010). Reading strategy use, self-efficacy and EFL reading comprehension. *The Asian EFL Journal Quarterly*, 12 (2), 18-42.
- Skaalvik, E. M., Skaalvik, S. (2007). Dimensions of teacher self-efficacy and relations with strain factors, perceived collective teacher efficacy, and teacher burnout. *Journal of Educational Psychology*, 99 (3), 611-625.
- Skaalvik, E. M., Skaalvik, S. (2010). Teacher self-efficacy and teacher burnout: A study of relations. *Teaching and Teacher Education*, 26 (4), 1059-1069.
- Tilfarlioglu, F. T., & Ciftci, F. S. (2011). Supporting self-efficacy and learner autonomy in relation to academic success in EFL classrooms (A case study). *Theory and Practice in Language Studies*, 1 (10), 1284-1294.
- Wang, J., Spencer, K., & Xing, M. (2009). Metacognitive beliefs and strategies in learning Chinese as a foreign language. *System*, 37, 46-56.
- Wang, C., & Li, Y. (2010). An Empirical study of reading self-efficacy and the use of reading strategies in the Chinese EFL context. *The Asian EFL Journal Quarterly*, 12 (2), 144-162.
- Yanar, B., Bumen, N. T. (2012). Developing a self-efficacy scale for English. *Kastamonu Education Journal*, 20 (1), 97-110.
- Yilmaz, C. (2010). The relationship between language learning strategies, gender, proficiency and self-efficacy beliefs: a study of ELT learners in Turkey. *Procedia -Social and Behavioral Sciences*, 2, 682–687.
- Zimmerman, B. J. (1999). Self-efficacy: An essential motive to learn. *Contemporary Educational Psychology*, 25 (1), 82-91.

# Examination of Parents' Problems in the Process of Inclusive Education

Gulden Ozturk Serter, Sukran Simsek, Yesim Yurdakul, Aynur Butun Ayhan

## 1. Introduction

Individuals who are significantly different from their peers in terms of their individual characteristics and educational competence for various reasons are defined as special needs individuals (Aral & Gursoy, 2012; Ataman, 2013). The least restrictive environment, defined as the training environment in which the special needs children can be together most with his or her peers, is possible through the inclusive education provided by the support special education services (McLaughlin & Jordan, 2005; Tastepe, Ozturk Serter, Yurdakul, Taygur Altuntas, & Butun Ayhan, 2017). The inclusive education, provision of special education services for special needs student and/or classroom teachers if necessary is continuing education in the normal education environment (Batu & Uysal, 2010; Chhabra, Bose, & Chadla, 2016).

In order for successful inclusive education to be successful, the physical conditions of the schools, supportive education services, number of students in the class, attitudes of their peers, attitudes and experiences of teachers and school personnel as well as the academic success of the student with special needs and social skill are very essential (Gurgur & Uzuner, 2010; Sucuoglu & Bakkaloglu, 2015; Tasdemir & Ozbesler, 2017). As is the case in the world, many precautions have been taken in also our country to ensure equality of opportunity in education and to succeed in the inclusive education (Aral, Gursoy, & Simsek, 2017; Butun Ayhan & Babacan, 2016).

It is emphasized that the inclusive education is beneficial to special needs kid by various researches that contribute to the children and families and even the teachers who do not need it (Chhabra et al., 2016; Sucuoglu & Bakkaloglu, 2015; Tasdemir & Ozbesler, 2017). Despite all the precautions taken, it is stated that the inclusive education has various problems in the implementation process, the lack of adequate special education support services for these problems, and the fact that teachers do not have enough knowledge and experience about the inclusive education (Gurgur & Uzuner, 2010). It is also emphasized that families with disabled children have concerns about the rejection of their children during the inclusive process.

When the literature is examined, studies point out that examination of teachers' view related the integration process (Sadioglu, Bilgin, Batu, & Oksal, 2013; Esmer, Yilmaz, Gures, Tarim, & Delican, 2017; Monsen & Frederickson, 2004), problems that families experience because of having disabled children (Azeem, Dogar, Shah, Cheema, Asmat, Akbar, Kousar, & Haider, 2013; Icoz & Baran, 2002; Kacan Softa, 2013; Kaytez, Durualp, & Kadan, 2015; Resch, Elliott, & Benz, 2012), families' views on integration process (Kargin, Acarlar, & Sucuoglu, 2003; Oncul & Batu, 2005; Ozyurek, 2015). However, it is noteworthy that the studies on the identification of the problems that special needs children have experienced in this process are limited. It is thought that this study, which aims to determine the opinions of the parents of the children who attend integration education in primary education schools about the problems they have experienced during integration education, will contribute to the field.

## 2. Method

This section includes the model of the research, the characteristics of the participants, the data collection tool and the process, and information about the analysis of the data.

### 2.1. Research Model

It is aimed to determine the opinions of the parents of the children who are continuing inclusive education in the primary school about the problems they have experienced in the inclusive education process. For this purpose, the casestudy method from qualitative research methods has been used. The case study is a qualitative research method in which the factors related to one or more situations

(events, processes, individuals, time, environment, etc.) are analyzed in a holistic approach within their limits, and how these factors affect the related situation and how they are affected from the situation are examined in detail (Yildirim & Simsek, 2016).

## 2.2. Participants

In the study determined by purposeful sampling method in accordance with the method of case study, the study group constitutes parents who have children who are getting inclusive education in primary schools at Sungurlu district in Corum province. 53.3% of the parents interviewed have consisted of mothers (n=8) and 46.7% of them are fathers (n=7). Four of mothers are between ages of 31-36 years, two of them are between the ages 37-40 years, two of them are 46 years and above. Two of mothers are non-literate, three of them are middle school graduate, one is primary school graduate, one is high school graduate and one is university graduate. One of between the fathers interviewed is between the ages of between 31-36, three of them are the ages of 37-40, two of them are the ages of 46 and above, and one of them is between the ages of 41-45. There are also three fathers of them are primary school graduate, one is middle school graduate, one is high school graduate and one is university graduate, while one of the father is non-literate. When demographic information on children is examined, it has been determined that one of the children is 8 years old, two childrens are 9 and 10 years old, three children are 11 years old, four children are 12 years old and one of them is 13 and one of them is 15 years old respectively. When children's type of disability is examined, it has been determined that two children have hearing impairment, one child has autism, one child is highly gifted, one child has a special learning disability, and ten children have mental inadequacy. It has been determined that one of the children was diagnosed before the birth, fourteen children were diagnosed postnatally; while the period of special education utilization is concentrated between 2-3 years (4 children) and 4-5 years (5 children), and 3 children have special education for 1 year and 6 years. In addition, it has been determined that two of the children in the study group who have been in full-time the inclusive education for one year, eight of them have continued to inclusive education for 2-3 years and five of them have been for 4 and more years.

## 2.3. Data collection tools and analysis of data

In this study, a semi-structured interview form prepared by the researchers in accordance with the qualitative data collection method has been used. In addition to the interview form, an individual information form prepared by the researchers has been used to determine the personal information of the participants. In the interviews with the participants, the data obtained by the voice recorder have been listened and written texts have been converted. It has been specified that the information recorded prior to the interview have been used only for scientific purposes and the participants have been informed about the confidentiality of the information, has been thought that it would be an important factor in ensuring mutual trust and the collected data would reflect the real situation. The content analysis method has been used in the analysis of the data obtained from the interviews on qualitative data analysis in this study. The audio responses to the interview questions have been converted into written text and the themes and sub-themes have been determined according to the answers given. The themes have been subjected to content analysis and analyzed to determine frequency and percentage on the obtained data. Then, the themes and sub-themes have been arranged and the findings obtained have been interpreted.

## 3. Findings

This section contains findings on data obtained through semi-structured interviews with parents who are continuing their children's inclusive education.

### ***Parents' views on whether their children are satisfied with the inclusive education***

In the interviews, parents have been asked whether their children are satisfied with their education in the inclusive environment. Thirteen of the parents said they were satisfied with the inclusive education their children and the two have been not satisfied. Some of the participant parents' responses to this issue are as follows:

## Examination of Parents' Problems in the Process of Inclusive Education

*“Yes, satisfied. Because she/he has been friends”(L). “Yes, she/he is satisfied in my opinion. It is better than special education. It was difficult first, but then she/he socialized with his friends”(K). “Yeah. My son is very happy. I observe that she/he is eager to go to school”(B). “No, not satisfied. She/he is also going to special education. There is special interest in the education she/he gets and he is getting individual training. I think there is special interest and individual educational expectation in the school where she/he has been integrated. He is also depressed because he is not good to write as well as his friends, difficult to write, and tired quickly so that she/he is upset”(S).*

### **Parents' view about whether they are satisfied with the inclusive education**

Parents have been asked whether they are satisfied with the inclusive education. 11 of the parents are satisfied with the inclusive education of their children and 4 are not satisfied. Some of the answers given by parents in this regard include:

*“Yes, I am satisfied. My child has developments. Now, she/he is a social child”(M). “Yes, I am satisfied; she/he is involved in society here”(D). “Yes, she/he left some negative behaviors after going to inclusive education”(K). “Some of the other children are going to go forward, I guess remaining of them are stabile. They are interested in easy learners or not interested in ones who can't learn easily or I don't know, they should have additional training. A better education can be given”(G).*

### **Parents' expectations on inclusive education**

Parents whose children are continuing their child's inclusive education have been asked about their expectation from the inclusive education. Five of parents reported an expectation that their children on inclusive education would be able to continue their education, go to school, and read. Five of parents stated expectation that are anticipating the socialization of their children regarding the inclusive education. Two of the parents stated that the parents of the inclusive education are expecting information and family education. One of the parents expressed the expectation of teachers about self-improvement education. One of the parents stated that physical arrangements for children with special needs for inclusive education and the expectation of ancillary personnel. Two of the parents said that the increase in the quality of education is the expectation, and the content of the inclusive education of the wunderkind and gifted children should be increased. Some of the participant parents' responses to this issue are as follows:

*“I am satisfied with education, enough to go to normal school”(N). “Less social than before primary school. My child has friends only in a private education school. Other than that, we were closing in. When we got together with the neighbors, the children of the other ladies kept away from my daughter. The biggest anticipation is to socialize, to be friends, not to be alone”(E). “It would be very helpful for us to organize meetings about matters such as informing, orienting, and understanding what to do with the other children with the integration student's parents”(B). “I expect the teachers to be educated enough about inclusive education, the school administration and other teachers to be more understanding and conscious about it. Teachers' self-improvement”(P).*

### **Parents' evaluations for approaches of school administration**

Parents whose children are continuing to the inclusive education have been asked whether they are satisfied with the approach of the school administration. Fourteen of the parents have been informed to be satisfied with the school management's approach, and one of the parents gave the opinion that the approach should be better. Some of the participant parents' responses to this issue are as follows:

*“They behave very well. We did not have a problem”(D). “I have not seen a negative behavior of the school administration”(M).*

### **Parents' evaluations for teacher's approach**

Parents whose children are continuing to the inclusive education have been asked how they evaluated the teacher's approach in the interviews. Parents have told that the teacher is doing well for his children and that he is a good teacher. Three parents evaluated their teachers as interested, regular



and kind. One parent stated that the teacher is disciplined, and one said that they behaved equally to the children. Some of the answers given by parents in this regard include:

*The teacher is trying to treat children and other children equally. Sometimes I think it is difficult”(A). “He’s behaving well, my child. When it is difficult (learning, doing homework) he/she does not force much”(M). “A disciplined teacher wants children to be more successful. I did not encounter a negative situation in our approach”(B).*

#### **Parents’ evaluations of other parents’ children and their approaches to them**

In the interviews with parents whose children are continuing to inclusive education, they have been asked how other parents evaluated the child and their approach to them. All of the parents stated that they did not have a problem with the other parents and they did not see a negative attitude. Some of the participant parents’ responses to this issue are as follows:

*“They behave well, I do not have any problems”(M). “I have not experienced any problems until now. They are good and understanding”(L). “I did not see any negative behavior. They behave well”(A).*

#### **Parents’ evaluations about children of peers about and their approaches**

Parents whose children are continuing to inclusive education have been asked in the interviews how their peers assessed their approach to the children and themselves. Parents have stated that they are having problems with their children’s in the early sessions of inclusive education, that peers are difficult to understand, excluded, distracted, and ridiculed their children, but over time they have accepted their children and have become accustomed to her/him and have no problem with their children now. 4 parents stated that the child does not have any problems with her/his peers and they like and behave well for their children. One of the parents said that their peers sometimes ridicule their child. Some of the answers given by parents in this regard include:

*“When we first started, we met with the negative behavior of her/his peers. The children then accepted the characteristics of my son different from them and socialized with her/him”(C). “Sometimes they make fun of my child”(H).*

#### **Parents’ views on their children problems in the inclusive education**

Parents whose children are continuing to inclusive education have been asked about the problems that their children experienced during the inclusive education. Three of the parents stated that they had a problem because their children did not want to do homework, and 5 of the parents stated that their children were afraid because of their peers’ children and distant from their peers. Two of the parents stated that the problem of living is that their child does not want to sit in her/his place. Three parents stated that they had problems because their children could not adapt to their education, their teachers and their peers, and the three parents stated that the child did not want to go to school, to escape from school, and to be unwilling against classes. A parent has stated that education is problematic in that materials, programs and observation techniques are inadequate, that a parent stated financial support is not enough by the state, and that a parent is having problems due to lack of assistant staff. Some of the participant parents’ responses to this issue are as follows:

*“We have a problem with doing homework. She/he does not like to do homework. That is why it is difficult to write and while writing, she/he has in difficulty”(S). “The state must provide financial support for the education of these children. Which education we want is based on the economy”(F). “Our biggest problem is about sitting at her/his place. She does not like to sit”(A).*

#### **Parents’ views on their children’ success in the inclusive education**

Parents whose children are continuing to the inclusive education have been asked how they saw the success of their children in the inclusive education. Ten of the parents said that they found the child successful at their own level, two of them found their children as successfully above the average of the classroom, two of them found their children unsuccessfully and one of them saw the child’s academic success on the second plan, the important thing is the socialization of their child. Some of the participant parents’ responses to this issue are as follows:

*"I find her/him good for her/his level, I can not compare it with other students"(L). "I find my child successful above of the class average"(B). "I think she/he is not successful. She/he fails both by herself/himself and by her/his friends"(H).*

#### ***Parents' views about whether they get complaint on their children behavior or success in the inclusive education***

Parents whose children are continuing to the inclusive education have been asked whether they got complaints on their behavior or success in the inclusive education. 4 of the parents stated that they did not get any complaint on their children. 3 of the parents stated that they got complaints on not sitting in the class, 2 of them stated that got complaint because of escaping behavior from school, 3 of them said that they got complaints on her/his child's behavior problems related to her/his disinterest towards the classes. Some of the answers given by parents in this regard include:

*"I get a complaint from his teacher about my son is standing up and moving around in his class"(A). "I'm getting complaint on her/his escape from school."(G). "Sometimes I get complaints about spitting behavior"(P).*

#### ***Parents' views on their children's continuance to the inclusive education***

Parents whose children are continuing to the inclusive education have stated that they want their parents to continue the inclusive education when they are asked whether 10 of them want to continue the inclusive education or that 2 of them want to continue because they have no other option and the other two of them want to continue in the special education classroom where they do not want the inclusive education. Some of the participant parents' responses to this issue are as follows:

*"I want. Because my son is happier in the inclusive, than the special education we have received before. She/he is at the same time more social than private education"(C). "I want her/him to be a private subclass. I would like the source room. Read, for example, she/he learnt in special education. There has been no progress with the education given here"(H).*

#### **4. Discussion and Conclusion**

In this study, it was aimed to determine the opinions of the parents of the children attending the inclusive education in the primary schools about the problems they experienced in the integrated education process. In the study, it was determined that the vast majority of the parents and their children were satisfied with the integration application the child had received. This satisfaction is thought to be due to the fact that the child has the possibility to integrate with the society, the integration environment allows children to socialize, the decrease of the problem behaviors, the socialization of the children in the inclusive environment, sourced from having interested of the teachers and the administrators. Parents who are dissatisfied with their children's integration application may be concerned that their children can't get individual education, that the normal school curriculum does not meet the real needs of children with disabilities and that they are academically challenged. It can be said that dissatisfied parents find inclusive education as inadequate. Among the main benefits of inclusive practice are the social and emotional benefits of adopting children and the social acceptance of the child (Leyser and Kirk, 2004). This finding is similar to other research results (Guralnick, Connor and Hammond, 1995; Palmer, Fuller, Arora and Nelson, 2001; Kargin et al., 2003).

The vast majority of the parents who participated in the study positively assessed the teacher's behavior and school administrators' against the children. In similar studies, it has been concluded that teachers were satisfied with their integration practices (Scruggs and Mastropieri, 1996; Sarac and Colak, 2012). It is emphasized that variables such as age, gender, grade level and the special education they receive may affect the attitudes of the teachers towards their integration with classroom attendance, support services, integration period, rate of handicapped and non-handicapped students in the class and the characteristics of disabled children (Temel, 2000; Sunbul and Sargin, 2003).

In the study it was determined that some of the parents' expectations are socializing their children's children from the integration environment. In addition, it is emphasized that inclusion and informing of families in integration education is one of the important factors in success of integration

programs (Sucuoglu, 2008, Aral, 2011). It was determined that some parents in the study are expecting parents to be informed and educated about the inclusive education. In this direction, this study shows that parents need to be informed in the process and they are in need of education and they are open to cooperating in terms of success of integration. It was also determined that some parents in the study have expectations about improving physical conditions and increasing the quality of education. The appropriateness of the physical conditions of the school or class appears to be one of the factors increasing the success of the integration practices (Gurgur, Kis and Akcamete, 2012; Aral and Gursoy, 2012). Studies have shown that parents are in a positive attitude towards the educational environments where their children are involved (Cross, Traub, Hutter-Pishgahi, and Shelton, 2004, Kalyva, Georgiadi, and Tsakiris, 2007).

In the study, it was determined that parents evaluated other parents' approaches to them and children positively. Results that are similar to those of parents 'positive evaluations of other parents' approaches are in the literature (Most and Ingber, 2016). It was also determined that parents have lived the problems between their children and their peers when they first started the inclusive process and that there were no problems after they experienced some problems.

It has been determined that parents experience problems such as being anxious, fearful, distracted, reluctant to do homework, having problems with sitting in their place, having problems with education, teaching and peer adjustment, not wanting to go to school and escaping from school in relation to the problems their children experience in the integration education environment. It is thought that children experience are problems that can be solved with support special education services and guidance services, but children and their families have experienced the problems mentioned above due to deficiencies in integration practices.

In the study, the majority of the parents considered the success of their children as successful according to their level. This finding can be interpreted as the fact that the expectation of the families about the success of the children is directly proportional to the level of their children, not above the capacity of their children.

When parents' preferences for their children's educational settings are examined, it has been determined that most of them want their children to continue their integration education, some want to continue integration education because there is no another option, and some parents prefer to receive education in a special education class instead of integration education. It is thought that the reasons for these considerations may be the experience of integration, dissatisfaction with integration practice, or the type of disability of the child.

Assessment of development at Guidance Research Centers prior to inclusion of children with disabilities in the integration process, preparation of the child-appropriate IEP (Individualized Education Program) and co-operation with the classroom teacher are one of important steps for success. With support services, educators and school staff should be trained on the integration of children with disabilities and their integration, and the continuity of these educations should be ensured. The regular provision of seminar programs for parents to support their children's education and to develop them on issues that challenge them, such as child development and discipline, constitutes also one of requirements for success.

## References

- Aral, N. (2011). *Okul oncesi egitimde kaynastirma*. Istanbul: Morpa Yayinlari.
- Aral, N. & Gursoy, F. (2012). *Ozel egitim gerektiren cocuklar ve ozel egitime giris*. Istanbul: Morpa Yayinlari.
- Aral, N., Gursoy, F. & Simsek, S. (2017). Isitme engelli cocuk annelerinin haklarına ilişkin dusuncelerinin incelenmesi. *Egitim ve Ogretim Arastirmalari Dergisi*, 6(3), 64-77.
- Ataman, A. (2013). Ozel egitimin temelleri. In A. Cavkaytar (Ed.), *Ozel egitim* (pp. 1-19). Ankara: Vize Yayıncılık.
- Azeem, M. W., Dogar, I. A., Shah, S., Cheema, M. A., Asmat, A. Akbar, M. , Kousar, S., & Haider, I. I. (2013). Anxiety and depression among parents of children with intellectual disability in pakistan. *Journal of the Canadian Academy of Child and adolescent Psychiatry*, 22(4), 290-295.

- Batu, S. & Uysal, A. (2010). Gunumuz siniflarinda engeli cocuklarin katilimini destekleme. In: G. Akcamete (Ed.), *Genel egitim okullarinda ozel gereksinimi olan ogrenciler ve ozel egitim* (pp. 113-140). Ankara: Kok Yayıncılık.
- Butun Ayhan, A. & Babacan, A. (2016). Okul oncesi ogretmenligi: Alan bilgisi. U. Deniz, N. Aral ve A. Kan (Ed.), *Kaynastirma* (pp. 665-681). Ankara: Alan Bilgisi Yayınları.
- Chhabra, S., Bose, K., & Chadha, N. (2016). Botswana early childhood educators' perceptions on factors associated with the inclusion of children with disabilities. *International Journal of Learning, Teaching and Educational Research*, 15(3), 1-19.
- Cross, A.F., Traub, E.K., Hutter-Pishgahi, L., & Shelton, G. (2004). Elements of successful inclusion for children with significant disabilities. *Topics in Early Childhood Special Education*, 24, 3, 169-83.
- Esmer, B., Yilmaz, E., Gunes, A. M., Tarim, K., & Delican, B. (2017). Sinif ogretmenlerinin kaynastirma ogrencilerinin egitimine iliskin deneyimleri. *Kastamonu Egitim Dergisi*, 25(4), 1601-1618.
- Guralnick, M. J., Connor, R. T., & Hammond, M. (1995). Parent perspectives of peer relationships and friendships in integrated and specialized programs. *American Journal on Mental Retardation*, 99, 5, 457-476.
- Gurgur, H., Kis, A., & Akcamete, G. (2012). Examining pre-service teachers opinions about providing individual support services to mainstreaming students. *Elementary Education Online*, 11, 3, 689-701.
- Gurgur, H., & Uzuner, Y. (2010). Kaynastirma sinifinda is birligi ile ogretim uygulamalarina bakisin fenomenolojik analizi. *Kuram ve Uygulamada Egitim Bilimleri*, 10(1), 275-333.
- Icoz, A., & Baran, G. (2002). Zihinsel engelli cocuklara sahip annelerin kaygi duzeylerinin incelenmesi. *Cocuk Gelismesi ve Egitimi Dergisi*, 1(6-7), 80-90.
- Kacan Softa, H. (2013). Engelli cocuga sahip ebeveynlerin depresyon duzeylerinin incelenmesi. *Kastamonu Egitim Dergisi*, 21(2), 589-600.
- Kalyva, E., Georgiadi, M., & Tsakiris, V. (2007). Attitudes of Greek parents of primary school children without special educational needs to inclusion. *European Journal of Special Needs Education*, 22, 3 295-305.
- Kargin, T., Acarlar, F., & Sucuoglu, B. (2003). Ogretmen, yoneticisi ve anne babalarin kaynastirma uygulamalarina iliskin goruslerinin belirlenmesi. *Ozel Egitim Dergisi*, 4 (2), 55-76.
- Kaytez, N., Durualp, E., & Kadan, G. (2015). Engelli Cocugu Olan Ailelerin Gereksinimlerinin ve Stres Duzeylerinin Incelenmesi. *Egitim ve Ogretim Arastirmalari Dergisi*, 4(1), 197-214.
- Leyser, Y., & Kirk, R. (2004). Evaluating inclusion: an examination of parent views and factors influencing their perspectives. *International Journal of Disability, Development and Education*, 51, 3, 271-285.
- McLaughlin, M. J., & Jordan, A. (2005). Push and pull: Forces that are shaping inclusion in the United States and Canada. In D. Mitchell (Ed.), *Contextualizing inclusive education* (pp. 89-113), New York: Taylor & Francis.
- Monsen, J. J., & Frederickson, N. (2004). Teachers' Attitudes Towards Mainstreaming and Their Pupils' Perceptions Of Their Classroom Learning Environment. *Learning Environments Research*, 7, 129-142.
- Most, T., & Ingber, S. (2016). Effects of exposure to inclusion and socioeconomic status on parental attitudes towards the inclusion of deaf and hard of hearing children. *Deafness & Education International*, 18, 3, 124-133.
- Oncul, N. & Batu, S., (2005). Normal gelism gosteren cocuk annelerinin kaynastirma uygulamasina iliskin gorusleri. *Ankara Universitesi Egitim Bilimleri Fakultesi Ozel Egitim Dergisi*, 6(2) 37-54.
- Ozyurek, A. (2015). Okul oncesi donem kaynastirma uygulamasina cocuk, veli ve egitimci bakis acisinin incelenmesi. *Uluslararası Aile Cocuk ve Egitim Dergisi*, 6, 82-102.
- Palmer, D.S., & Fuller, K. (2001). Taking sides: parent views on inclusion for their children with severe disabilities. *The Council for Exceptional Children*, 67, 4, 467-484.
- Resch, A. J., Elliott, T. R. & Benz, M. R. (2012). Depression among parents of children with disabilities. *Families, Systems, & Health*, 30(4), 291-301.

- Sadioglu, O., Bilgin, A., Batu, S., & Oksal, A. (2013). Sınıf öğretmenlerinin kaynastirmaya ilişkin sorunlari, beklentileri ve önerileri. *Kuram ve Uygulamada Egitim Bilimleri*, 13(3), 1743-1765.
- Sarac, T., & Colak, A. (2012). Kaynastirma uygulamalari surecinde ilköğretim sınıf öğretmenlerinin karsilastiklari sorunlara ilişkin gorus ve önerileri. *Mersin Universitesi Egitim Fakultesi Dergisi*, 8, 1, 13-28.
- Scruggs, T. E., & Mastropieri, M. A. (1996). Teacher perceptions of mainstreaming/inclusion, 1958-1995: A research synthesis. *Exceptional Children*, 63, 1, 59-74.
- Sucuoglu, B. (2008). Aile katiliminin artırilmasi. In B. Sucuoglu & T. Kargin, (Ed.), *Ilköğretimde kaynastirma uygulamalari yaklasimlar, yontemler, teknikler* (pp. 339-364). Istanbul: Morpa Yayinlari.
- Sucuoglu, B. & Bakkaloglu, H. (2015). Okul oncesinde kaynastirma: Öğretmen eğitimi. Ankara: Pegem Akademi.
- Sunbul, A.M., & Sargin, N. (2003). Okul oncesi donemde kaynastirma eğitimine ilişkin öğretmen tutumlarinin (Cesitli degiskenler acisindan) incelenmesi. *XII. Ulusal Özel Egitim Kongresi*. Ankara Universitesi Egitim Bilimleri Fakultesi Yayinlari, Yayin No: 193.
- Tasdemir, H., & Ozbesler, C. (2017). Kaynastirma eğitimine devam eden cocuklarin karsilastiklari sorunlarin okul ortaminda sosyal hizmet uygulamalari perspektifinde degerlendirilmesi. *Uluslararası Sosyal Arastirmalar Dergisi*, 10(49), 498-507.
- Tastepe, T., Ozturk Serter, G., Yurdakul, Y., Taygur Altintas, T., & Butun Ayhan, A. (2017). Turkiye’de okul oncesi donemde kaynastirma konusunda yapilan lisansustu tezlerin incelenmesi. *International Journal Of Social Science*, 49, 501-514.
- Temel, F. (2000). Okul oncesi eğitimcilerin engellerin kaynastirilmasina ilişkin gorusleri. *Hacettepe Universitesi Egitim Fakultesi Dergisi*, 18, 148-155.
- Yildirim, A., & Simsek, H. (2016). Sosyal bilimlerde nitel arastirma yontemleri. 10. Baski. Seckin Yayıncılık: Ankara.

# Teachers' Perceptions Related to the Usability of Subliminal Messages in Education

Hasan Arslan, Muzaffer Ozdemir, Meltem Kuscü

## Introduction

It was seen that the word "subliminal" is referred to with different words such as subconscious or subprime (Cetin, 2013; Izgoren, 2014). Therefore, in order to get a better grasp of this word, it is beneficial to know the factors affecting the subconscious. According to Psychoanalysis theory of Freud, the subconscious represents a big portion of our brains. In the iceberg example given on this subject, the subconscious is likened to the hidden part of the iceberg (Guler, 2008; Eldem, 2009; Yolcu, 2010; Ozturk, 2014; Solmaz, 2014; Erdem, 2015). Although our behaviors tend to be associated with conscious, in effect they are not only associated to the conscious but also to the subconscious. According to Izgoren (2014), the conscious has the ability to perceive, assess and eliminate whereas the subconscious does not. Our brain encounters approximately 2000 inputs every day. While very few of them are perceived by the conscious, the rest, which is the majority of it, is accepted by the subconscious as input. It is not possible to change the input placed in the subconscious. Moreover, when this information planted to the subconscious is primed with international propaganda purposes, it can be turned into a political tool which causes massive effects. For instance, Izgoren (2014) in his book "Esikalti Buyuculeri" (Magicians of Subthreshold) expresses that in the gulf crisis years, people only remembered the struggling cormorant covered in oil rather than dying babies and the embargo on medicines; because people believe in what they are shown. Violent scenes on television or computer screens can be examples to how the subconscious of our young ones is exposed to negative effects.

The first findings related to subconscious is influenced by visual perceptions emerged in the 1930's. In a movie shot in these years Marlon Brando did not wear a t-shirt under his shirt so a decrease in the sale of t-shirts occurred; and in his movie filmed in the 50's, Marlon Brando did wear a t-shirt and this lead to a boom in sales (Biskin, 2014). This turned out to be an opportunity to observe the influence of the film industry on people's choices. The subconscious has the ability to catch messages that are perceived by our sense organs and overlooked by our conscious. For example, in a study carried out on subconscious related to smells and sounds, it was seen that pregnant women who shop in restaurants where the aisles are sprayed with baby cologne and peaceful calm music is broadcasted, spend more time in these shopping malls and when their babies are born, they only calm down when taken to these particular malls (Biskin, 2014).

Korkmaz (2015) who comments on why subliminal content is prepared especially for children, while emphasizing that adult oriented products are tried to be sold by using sexual content, affirms that children are primed for this kind of content at an early age so that companies invest in the sale of their products for the future by creating an influence on children's minds in advance. Koccaz (2015) reviewed two videos related to the subconscious in his study. One of the videos is about how we think everything we see is all about our imagination but we are influenced by what we see around us. The researcher, who investigated the second video within the context of subliminal messages, interpreted the sunglasses scene on the American production movie titled "They Live" of the year 1988. In this scene, aliens invade the earth and send some secret messages and signals to people's brains through these sunglasses. When people put on the sunglasses they see messages like "I am your God", "Obey" and "Buy" on objects such as money, billboards etc. These movie scenes constitute a good example of subliminal messages.

In the study of Atas, Faivre, Timmermans, Cleeremans and Kouider (2014) which questions whether people can learn complicated information unconsciously, the participants were asked whether they could consciously perceive the differences between a series of symbols and it was concluded that sensitivity for successiveness could emerge with the help of the time-wise integration of unconsciously perceived information. In this study, the researchers discovered that the participants could learn a

series of stimuli they did not perceive consciously. Besides, the unconscious learning effect they found was potentially a combination of learning during perception (ex: binding together the successive stimuli) and operant conditioning (a behavior that both leads to a reward and to punishment avoidance).

There are some factors influencing the subconscious. These factors may vary from person to person or from society to society. However, there are two unchanging factors one of which is birth described with sexuality, meaning, the beginning of life; and the other is death described with fear, meaning, the end of life (Eldem, 2009; Solmaz, 2014).

### **Subliminal Message Techniques**

The 25<sup>th</sup> Frame technique (Solmaz 2014; Erdem, 2015), subconscious symbols (Solmaz, 2014) and the backmasking technique (Biskin, 2014) can be given as examples to subliminal message techniques. The most common subliminal message technique among these is the 25<sup>th</sup> Frame technique. The 25<sup>th</sup> Frame technique is about a single frame given right after the 24 frames shown within one second and shown only on the 25<sup>th</sup> frame in order to obtain motion. Any message can be placed on this single frame area whether or not relevant to the plot of the movie. It is stated that this message is not received by the conscious mind but by the subconscious mind (Cetin, 2012; Erdem, 2015). The subconscious symbols may be checkered background, single eye or the number 666 (Solmaz, 2014). As for backmasking, it is prepared by showing a detail in the background which may not directly draw attention but can be noticed by the subconscious mind (Erdem, 2015). Apart from visual subliminal messages, auditory subliminal messages are used as well (Biskin, 2014). People are able to hear sounds between 20 Hertz and 20.000 Hertz (Solmaz, 2014). Subliminal messages can be sent to people's subconscious mind using frequencies distinct from these. For instance, according to a study carried out by Lindstrom (2008), it is claimed that the subliminal messages like "*don't worry about money*" or "*don't try to steal it or you'll get caught*" hidden in the lyrics of the songs at malls where jazz and Latin music are played reduces the rate of robbery at those malls. (Lindstrom, 2008, quoted by: Solmaz, 2014).

### **The Purpose and the Areas of Use of Subliminal Messages**

It can be said that subliminal messages are generally used with the purpose of influencing people's mental instincts and directing them to the desired direction. It can be expressed that in this way the main purpose is to raise individuals who do not think, only consume and chase after pleasure. Moreover these messages are transmitted not only through hidden objects but also through dialogues that are against the cultural codes of society like slang words (Cetin, 2013).

Politics, advertising, cinema, music, cartoons and games can be mentioned among the areas of use of subliminal messages (Guler, 2008). According to Yolcu (2010), the most common areas of use of subliminal messages are movies, television series, sports competitions, novels and stories, computer games, songs and music videos, news programs, caricatures, animations and advertisements.

Subliminal messages can be used to influence the reaction of people towards a strange object (Murphy and Zajonc, 1993). Subliminal advertising is a technique of exposing consumers to product pictures, brand names, or other marketing stimuli without the consumers having conscious awareness (Trappey, 1996). Subliminal advertising has been a subject of controversy ever since the 1950's (Verwijmeren, Karremans, Bernitter, Stroebe and Wigboldus 2013). It has been unclear for the last decade whether a subliminally presenting a brand name has been effective in influencing consumer choice (Verwijmeren et al., 2013). However, the literature demonstrates that preparing subliminal messages can be very difficult (Strahan, Spencer and Zanna, 2002). In a study carried out by Karremans, Stroebe and Claus (2006), it was seen that a subliminally primed beverage brand positively influenced participants (but only the thirsty participants) to choose this brand. These findings look worrisome in terms of ethics of subconscious persuasion techniques (Nebenzhalve Jaffe, 1998). Subliminal advertising operates via an automatic process of which people are not aware, which fuels the idea that people may not be able to protect themselves against this type of persuasion (Verwijmeren et al., 2013). In a meta-analysis study carried out by Trappey (1996), it was concluded that subliminal marketing stimuli have little effect in influencing customer choice. However, it was indicated that subliminal

priming will only affect people's behavior if the subliminal prime is goal-relevant like quenching thirst (Strahan, Spencer and Zanna, 2002). However, it is thought that only conscious needs can create this effect. Subliminal messages become more effective when they are related to or can potentially satisfy a physical need (Milyavsky, HassinveSchul 2012).

There have been some regulations Turkey related to advertisements which are considered as the most convenient media to transmit subliminal messages to people. As indicated in law of Turkey subconscious methods cannot be used in commercial communication. Due to this reason, some restrictions were imposed on the use of subliminal messages in Turkey and subliminal messages were continued to be used on billboards or posters in magazines instead of television screens.

## **Method**

### **The Research Model**

The method used in the study is the case study method which is a qualitative research method. Case study is a research method that allows the researcher to thoroughly examine an event or fact which cannot be controlled by the researcher with reference to the questions "how" and "why" (Yildirim and Simsek, 2011). CEIT teachers were selected for the study and by creating an analogous sampling with the study carried out by Arslan, Ozdemir and Kuscu (2017), the two studies were compared. In this manner, it was aimed to investigate whether similar or different results would be obtained in the two studies. Analogous sampling is defining a specific subgroup; for instance, choosing parents who have a lower level in terms of socioeconomic status and educational background for the parent-teacher association (Yildirim and Simsek, 2011).

### **Data Collection Tools**

Semi-structured interview questions were prepared with the aim of finding out the participants' perception related to the use of subliminal messages in education and their opinion on the issue. The meeting questions were prepared by the researchers in line with the researches done related to the topic and two experts, one from the Department of Education Science and the other from the Department of CEIT were asked for their reviews on the questions. These questions were used by being asked to CEIT students in the study of Arslan, Ozdemir and Kuscu (2017).

The interview is referred to as an interview in some sources. According to Creswell (2014), interview is carried out face to face or on the telephone with participants and is used to obtain in-depth information about the participants' opinions or reviews about the issue. According to Johnson and Christensen (2014), interview data is obtained through asking participants questions. In the study it was aimed to obtain information related to the existence of similarities or differences between the participants' perspectives on the issue. It was assumed that the participants have given honest answers.

### **Participants**

The participants of the study comprise of 10 CEIT teachers employed at different universities as well as at positions of the National Education. Their technical competence on the subject has been a significant factor in choosing CEIT teachers. Besides, CEIT teachers were preferred in order to be able to make a healthy comparison with the study conducted on CEIT students. In order to have a first-hand and fast access to data, convenience sampling method was preferred. Convenience sampling is a preferable sampling method due to easy access to participants and its usefulness (Creswell, 2014).

Considering the demographic features, it is seen that the number of participants of both sexes is equal (N=10, 5 female, 5 male, age range: 25-39). As for the age range, it is seen that the study was carried out on a 25 – 39 age range, on a section between the generation X and the generation Y. The generation X comprises the interval 1965 – 1979 while the generation Y comprises the interval 1980 – 1999 (Keles, 2011). In this case, it can be said that the study was done with a technology generation called "migrant" in the literature. The participants were named as P (number).



## Findings

Currently serving CEIT teachers were asked questions related to the topic with the purpose of evaluating the usability of subliminal messages in education. The data were thematized through content analysis and were presented as tables in accordance with the frequencies. Each opinion, particularly the expressions that were repeated the most in the answers given, was given place.

### **Question 1: What is a subliminal message in your opinion?**

Table 2: Definition of Subliminal Message According to the Participants

Item No	Participant Comments	f
1	Subconscious	7
2	Secret	4
3	Undercover	1

Seven participants used the expression “subconscious”, four used the expression “secret” related to subliminal messages. While one participant used the expression “undercover”, another participant described the word subliminal as a method of transmitting a message indirectly. One participant described it as a technique that influences our character.

The opinion of the participant P5 was: “*The real purpose which is not stated openly and is hidden under other concepts or expressions*”. The interpretation of the participant P10 was: “*I think they are messages that influence the subconscious in a positive or negative way.*”

As a result, it is possible to state that the revealed common themes were particularly described as subconscious and hidden messages. Besides, it was seen that the participants knew about the concept of subliminal message and they explained it with different interpretations. The most prominent definition was “the message that affects our subconscious”.

### **Question 2: What are the subliminal message techniques?**

Table2: Subliminal Message Techniques According to the Participants

Item No	Participant Comments	f
1	Hiding a message inside a video (auditory or visual)	5
2	25 <sup>th</sup> Frame Technique	2
3	Hiding a visual inside an object	1

When the participants’ comments were examined, expressions related to hiding inside a video were expressed by five participants in different manners. Two participants mentioned the 25<sup>th</sup> Frame technique. One participant described the subliminal message technique as a visual hidden inside an object. Two participants stated that they had no information about the topic.

The participant P1 explained the subliminal message technique as follows: “*Hiding two or three-dimensional figures into visual elements in a manner that cannot be noticed unless looked carefully. It can also be changing sound waves into deep frequencies that cannot be understood or sensed by people but can be perceived by the subconscious mind*”. The participant P4 who expressed a different opinion said: “*While 100 messages dealing with the main subject are being given in a text, giving one negative message in the opposite direction, related to another subject or refuting the main subject in a fashion that will not disrupt the cohesion of the text or it can be visuals, audio messages or sign language hidden in a video.*”

As a result, according to the answers given, it is possible to say that the participants have basic knowledge about visual and auditory techniques. The technique they concretely specified is the 25<sup>th</sup> Frame technique. They qualify the techniques as visual and auditory and they define them with a

## Teachers' Perceptions Related to the Usability of Subliminal Messages in Education

superficial and generic expression. It can be said that the participants have basic knowledge about the techniques rather than detailed and clear information.

**Question 3: To what extent do subliminal messages influence the subconscious in your opinion?**

*Table 3: The Level of Influence of Subliminal Messages on Subconscious According to the Participants*

Item No	Participant Comments	f
1	High level	5
2	Effective and harmful on children	2
3	Medium level	1

While five participants stated that subliminal messages influence the subconscious at a high level, one participant expressed that they have a medium level effect. While one participant stated that their effect could emerge in the long run, two participants expressed that they could be effective at an early age. One participant asserted that their subconscious was affected by subliminal messages but they did not know to what extent.

The participant P3's comment on the topic was: "Although they reveal their effects in the long run, they adapt themselves to our lives". The participant P46 stated the following related to the topic: "This is where the individual's attention comes in, if the brain catches and receives the subliminal message, it can involuntarily develop a habit for its future behavior". The participant P7 gave an answer related to who is affected more by it and said: "I think it can be very effective at early ages".

As a result, it was expressed that subliminal messages can have more effect on younger age groups. As far as understood from the expressions of the participants, it is thought that subliminal messages have the ability to cause a change in behavior especially on younger age groups. It can be concluded that the common opinion is that subliminal messages affect the subconscious mind at a high level.

**Question 4: In which subjects do you think subliminal messages would be more successful?**

*Table 4: Subjects in which subliminal messages can be successful according to the participants*

Item No	Participant Comments	f
1	Any subject	2
2	Verbal subjects	2
3	The computer subject	2

The participants gave a wide range of answers. Two participants indicated that subliminal messages could be used in any subject. Two participants said verbal subjects, two participants said computer, one participant said communication, one participant said education, one participant said visual arts and one participant said psychiatry. One participant had a different approach to the topic and said that they perceive it as a practice of imposing Christianity.

The participant P6's comment on the subjects in which subliminal messages can be effective was as follows: "They can be used in any subject and they can be successful. However, I am of the opinion that it would be more effective in verbal classes rather than in numerical classes". P9 gave the following answer related to the topic: "I think it can be effective by being employed in different ways in every subject. As for my subjects, I think it would be quite effective in information technologies". P10 who brought a different approach to the topic and drew attention to the abstract side of the topic: "I think it would be more successful in subjects that require abstract thinking or subjects that deal with details; for instance, psychiatry".

As a result, there were different opinions. It can be thought that the participants are of the opinion that this technique may be more effective on verbal subjects. It was also stated that it can be a method

which can be used in dealing with abstract subjects. In line with these answers, it can be said that the teachers think that subliminal messages may be more successful in verbal and abstract fields.

**Question 5: If you were to prepare a study for students, for students of which age group, in which subject and using which techniques would you prepare the subliminal message?**

*Table5: Age groups in which subliminal messages can be used according to the participants*

Item No	Participant Comments	f
1	High School	4
2	Middle School	4
3	Elementary School	1

*Table6: Subjects in which the participants want to use subliminal messages*

Item No	Participant Comments	f
1	Social Sciences	4
2	Technology	2
3	National Culture	1

*Table7: Subliminal message techniques that can be used according to the participants*

Item No	Participant Comments	f
1	Messages hidden in a video	5
2	25 <sup>th</sup> Frame technique	1
3	Cartoon	1

Four participants answered high school, four answered middle school and one answered elementary school related to the level of education. Two participants stated that they would not feel the need to prepare and use material with subliminal message content. As for subjects, it was mentioned that it can be used in history, social sciences, citizenship and national culture, educative videos, technology use, cyber bullying and adolescence. As for the method, five participants suggested messages hidden in a video. One participant mentioned the 25<sup>th</sup> Frame technique. One participant expressed that it can be used in the field of education through giving a message in cartoons.

The participant P6 answered: "I could prepare a video or an animation using the images and verbal expressions used in social sciences, my own branch, for students between the 3<sup>rd</sup> grade and the 6<sup>th</sup> grade". P8 who emphasized the informatics field answered: "I would hide messages about the conscious use of technology or cyber bullying into objects or videos in information technologies classes for middle school or high school students."

As a result, from the point of view of the participants, the answers given were focused more on middle school and high school students. Verbal fields were mentioned more. It can be concluded that the common opinion is that messages hidden in videos could be more effective.

**Question 6: What would you like to say about the negative image of subliminal messages?****Table 8: Evaluation of the negative image of subliminal messages according to the participants**

Item No	Participant Comments	f
1	There are many negative examples	6
2	There are no negative examples	2
3	It affects the subconscious mind adversely	2

It was seen that subliminal messages have a negative image among the participant teachers due to affecting the subconscious, affecting the subconscious involuntarily and having almost no positive examples. It was suggested that the fact that subliminal messages contain violence, sexual drive or negative thoughts and because they are mostly preferred in advertisements leads to the formation of prejudices about subliminal messages. It was also stated that contents that involve political messages cause people to make motivated choices instead of conscious ones.

The participant P4, speaking about social preferences, stated the following: *"Subliminal messages can usually be found in advertisements or political messages. And this may lead social preferences to change. Instead of making conscious choices, they may make motivated choices"*. The participant P5 explained the notoriety of subliminal messages by saying: *"The act of hiding the main purpose under another element gives the impression that that purpose is a bad one and especially the fact that it has been used for advertising etc. purposes until today is the main reason which makes it look bad"*.

As a result, all the participants expressed that the negative side of subliminal messages predominates. Participants who mentioned that they have not seen any positive examples of it expressed that people are exposed to the negative use of subliminal messages especially in advertising and politics. It can be said that there is the belief among the participants that social choices are affected by these messages which is why this is a matter which should be handled delicately.

**Question 7: Will you share your contributions related to the use of subliminal messages in education?****Table 9: Contributions of the participants**

Item No	Participant Comments	f
1	It can be used in positive fields (patriotism, high level and abstract thinking etc.)	6
2	It will only be effective in educative videos	2
3	It would not be a beneficial practice	2

Six participants were of the opinion that subliminal messages could be used in positive fields such as promoting patriotism and improving the ability to high level and abstract thinking. And two participants stated that they did not think that this would be useful and effective. It was seen that the positive perspective predominated.

The participant P2 made the following comment related to the use of subliminal messages: *"We can give this method a try to teach patriotism and being a citizen. Maybe this time we succeed"*. P6 who suggested that subliminal messages should not be used on their own expressed the following: *"I think subliminal messages should not be used on their own. The teacher should also give their message openly. They may be more effective if used together"*.

When the answers were examined in general, it was seen that the majority of the CEIT teachers has a positive point of view the matter. It was seen that, except for the two participants who defended that it was ethically objectionable to influence the subconscious, all the other participants were of the opinion that subliminal messages could be used particularly in verbal subjects. To sum up, from the

point of view of CEIT teachers, it can be said that subliminal messages can be used for education purposes.

### Conclusion and Discussion

In this study, the usability of subliminal messages in education was examined from the point of view of CEIT teachers. The result obtained is in line with the study of Arslan, Ozdemir and Kuscü (2017) and these two studies are consistent. It can be said that the only difference is the target audience. While CEIT students saw younger age groups as the target audience, CEIT teachers rather see middle and high school students as the target audience. Positive opinions were expressed related to the use of subliminal messages in the field of education. It was concluded that subliminal messages could be prepared especially in verbal and abstract fields. It was suggested that groups under the age of 18 could be educated with messages hidden in videos and this could yield positive results. It can be inferred that whether it can be adopted as an education method which makes learning easier at different levels of education depends on studies to be carried out in this field. Judging from the results of this study, it can be said that subliminal messages which are a part of technology and exist with technology can be used in education environments.

Subliminal messages are not about consciousness, but about the perception of consciousness. It is expected that the trainings to be made for the subconscious perception will be reflected in their behavior without being aware of the person. It is envisaged that the subliminal messages to be given with the subliminal perception methods that have been proven to be effective in the field will be used as a part of the education and will provide faster learning and faster behavior development in the students. For example, the values we have recently lost can be given to students through educational videos with subliminal messages. It can be said that special studies for students who have learning difficulties will be beneficial for the development of these children. An education that can be done with subliminal messages can find its place in practice in order to minimize the crime rate of children in disadvantaged areas. Subliminal messages can be used to teach spiritual topics, such as not just teaching lessons, but respecting differences. In short, this study has revealed that subliminal messages, which can be found in every field of education, should be integrated into educational environments as a useful material.

It is seen that due to the fact that they affect the subconscious mind, subliminal messages can create controversy even when they are used only for education purposes. It was revealed that subliminal messages which could not yet find their place in the field of education due to discussions of ethics, is a method which should at least be tried as an education material. It could be said that it would be more appropriate to discuss the ethical dimension of it after the pilot tests; because it will never get past a hypothetical discussion unless its potential positive effects in the field of education are seen.

By increasing the number of studies related to the usability of conventionally notorious subliminal messages in the field of education, it is possible to raise awareness on the issue and achieve innovation in education. In an environment of education where technology is so involved in our lives, contribution of subliminal messages, which can be described as a field nourished by technology, could become a necessity in education in time. It could be possible to include it in education environments by determining the fields on which it is more successful (for example, numerical, verbal, psychological, abstract thinking, learning disability) through pilot schemes.

### References

- Arslan, H., Ozdemir, M. ve Kuscü, M. (2017). Perceptions of Prospective ICT Teachers Regarding Usability of Subliminal Message Techniques In Education, *European Scientific Journal*, Vol.13, No.7, s. 81-94.
- Atas, A., Faivre, N., Timmermans, B., Cleeremans, A., & Kouider, S. (2014). Nonconscious learning from crowded sequences. *Psychological science*, 25(1), 113-119.
- Biskin, F. (2014). *Subliminal A. S. Tuket, Itaat Et*. Ankara: Elma Yayınevi.
- Creswell, J. W. (2014). *Arastırma Deseni Nitel, Nicel ve Karma Yöntem Yaklaşımları*, Ankara: Egiten Kitap Yayınları.

- Cetin, M. (2013). Medyatokrazi Uzerinden Kultur Endustrisinde Subliminal Mesajlarin Rolu, Yayinlanmamis Yuksek Lisans Tezi, Pamukkale Universitesi, Sosyal Bilimler Enstitusu, Sosyoloji Anabilim Dali, Denizli.
- Cetin, Y. (2012). Subliminal Mesajlar: Zihin Simsarlari, Fatih Universitesi, Genc Kariyer Penceresi. <http://www.kariyerpenceresi.com/?yazarlarimiz,23,148/subliminal-mesajlar-zihin-simsarlari.html>. Access Date: 7 Ekim 2015.
- Erdem, O. (2015). Televizyon ve Sinemada Gizli Reklam ve Subliminal Mesaj, Yayinlanmamis Yuksek Lisans Tezi, Marmara Universitesi, Sosyal Bilimler Enstitusu, Radyo Televizyon ve Sinema Anabilim Dali, Istanbul.
- Guler, H. (2008). Algilarin Otesi: Bilincalti Reklamcilik Bilincalti Reklamciligin Tuketici Davranislari Uzerindeki Etkileri, Yayinlanmamis Yuksek Lisans Tezi, Kocaeli Universitesi, Sosyal Bilimler Enstitusu, Halkla Iliskiler ve Tanitim Anabilim Dali, Kocaeli.
- Izgoren, A. S. (2014). *Esikalti Buyuculeri*. Ankara: Elma Yayınevi.
- Johnson, B. ve Christensen L. (2014). *Egitim Arastirmalari*, Ankara: Egiten Kitap Yayinlari.
- Karremans, J. C., Stroebe, W., & Claus, J. (2006). Beyond Vicary's fantasies: The impact of subliminal priming and brand choice. *Journal of Experimental Social Psychology*, 42(6), 792-798.
- Keles, H. N. (2011). Y Kusagi Calisanlarinin Motivasyon Profillerinin Belirlenmesine Yonelik Bir Arastirma, *Organizasyon ve Yonetim Bilimleri Dergisi*, 3 (2), Istanbul.
- Koccaz B. (2015). "Biraz Subliminal Mesaj, Biraz Tuketim", <https://zihingezintisi.wordpress.com/2015/01/08/biraz-subliminal-mesaj-biraz-tuketim/#more-245/>. Access Date: 7 Ekim 2015.
- Korkmaz, K. (2015). <https://zihingezintisi.wordpress.com/2015/01/08/biraz-subliminal-mesaj-biraz-tuketim/>. Access Date: 7 Ekim 2015.
- Kouider, S., & Dehaene, S. (2007). Levels of processing during non-conscious perception: a critical review of visual masking. *Philosophical Transactions of the Royal Society of London B: Biological Sciences*, 362(1481), 857-875.
- Milyavsky, M., Hassin, R. R., & Schul, Y. (2012). Guess what? Implicit motivation boosts the influence of subliminal information on choice. *Consciousness and cognition*, 21(3), 1232-1241.
- Murphy, S. T., & Zajonc, R. B. (1993). Affect, cognition, and awareness: affective priming with optimal and suboptimal stimulus exposures. *Journal of personality and social psychology*, 64(5), 723.
- Nebenzhal, I. D., & Jaffe, E. D. (1998). Ethical dimensioins of advertising executions. *Journal of Business Ethics*, 17(7), 805-815.
- Solmaz, I. (2014). Noroplazma Faaliyetlerinde Bilincalti Reklamcilik ve Tuketici Algisi Uzerindeki Etkisi, Yayinlanmamis Yuksek Lisans Tezi, Gediz Universitesi, Sosyal Bilimler Enstitusu, Isletme Anabilim Dali, Izmir.
- Strahan, E. J., Spencer, S. J., & Zanna, M. P. (2002). Subliminal priming and persuasion: Striking while the iron is hot. *Journal of Experimental Social Psychology*, 38(6), 556-568.
- Trappey, C. (1996). A meta-analysis of consumer choice and subliminal advertising. *Psychology & Marketing*, 13(5), 517-530.
- Verwijmeren, T., Karremans, J. C., Bernritter, S. F., Stroebe, W., & Wigboldus, D. H. (2013). Warning: You are being primed! The effect of a warning on the impact of subliminal ads. *Journal of Experimental Social Psychology*, 49(6), 1124-1129.
- Yildirim, A. ve Simsek H. (2011). *Sosyal Bilimlerde Nitel Arastirma Yontemleri*. Ankara: Seckin Yayıncılık.



# Turkish university students' varied musical experiences agreeableness levels

Mustafa Hilmi Bulut, Yeliz Kindaptepe, Baris Erdal, Turker Erol, Derya Kirac, Kubilay Yilmaz

## Introduction

From early 1990s on, personality psychologists has been more and more convinced that non-clinical individual differences could be summarized accurately with reference to five basic traits or tendencies: neuroticism, extraversion, openness, agreeableness, and conscientiousness. Taking this progress on the theoretical front into consideration, recent studies on music embarked on a systematic review of the uses of and preferences regarding music, and the Big Five framework referred to above. A glance at the literature reveals that, especially the studies carried out after 1950s, on the functions of listening music, mostly focus on individual differences.

A large number of studies investigated whether personality traits were hereditary or not. In one such study, Bouchard & Loehlin (2001) found that the personality traits are hereditary at a rate of roughly 40-50%, while environmental factors have a further 50% impact. With reference to these findings, one can forcefully argue that the personality traits can be shaped by environmental factors, and thus the genre of music one is exposed to, as discussed in the present study, can play a role.

In the context discussed here, Rentfrow and Gosling (2003) showed a positive correlation between the personality trait of openness to different experiences and the preference for expressive and complex music genres (e.g. blues, jazz, classic and folk music), and intense and rebellious music genres (e.g. rock, alternative and heavy metal). On the other hand, preference for optimistic and rather conventional genres of music (e.g. country, soundtracks, religious music and pop) were found to have positive correlations with agreeableness, extraversion, and conscientiousness, and a negative one with openness. Furthermore, the music genres which were considered energetic and rhythmic by the Rentfrow and Gosling (e.g. rap, hip-hop, funk and electronic dance music) were found to have positive correlations with extraversion and agreeableness (Rentfrow & Gosling, 2003). These correlations between the personality traits and music preferences were mostly verified by Delsing et al. (2008) in a replication study with Dutch teenagers (n=2334).

Ferwerda, Tkalcic and Schedl's (2017) study (n= 1415) reviewed the preferences of individuals in three basic age groups, for all the genres of music covered by the researchers. Their findings suggest that personality traits exhibit variance with reference to music listening behavior, and such variance may be even more emphasized for certain age groups. For instance, the teenagers (age: 12-19) exhibited a positive correlation between folk music ( $r = .101$ ) and agreeableness alone. This means that, for this age group, users with an inclination for agreeableness had a marked preference for folk music. The individuals from the young adult age group (age: 20-39) and with agreeableness personality trait, on the other hand, had a preference for listening country ( $r = .184$ ), folk ( $r = .110$ ) and pop music ( $r = .194$ ), while heavy metal was markedly less popular among this group. On the other hand, individuals with high scores of agreeableness in the middle age group (age: 40-65) exhibited negative correlation with preference for listening heavy metal ( $r = -.339$ ). This observation suggests that the highly agreeable participants in the middle age group have lower preference for heavy metal. Generally speaking, these results show that the users in teenager and young adult age groups had a wider variety in terms of their music listening behavior.

A study by Erdal (2009) observed negative correlation between the preferences of individuals with high levels of agreeableness, and rock-metal music which are deemed rebellious genres. In the same vein, Erdal and Kindaptepe's (2017) findings in two comprehensive studies on emotion, mood, and music preferences, run in parallel to the conclusions reached by previous literature. According to the final results of the two-stage research performed (n=1456), individuals with lower scores in openness but higher ones in extraversion and conscientiousness had a marked preference for pop music, whereas



individuals exhibiting higher levels of agreeableness had a preference for Turkish Folk Music. Similarly, Tekman's (2009) study revealed that individuals with high levels agreeableness had a stronger preference for local and popular genres.

The results of the study by Vuoskoski and Eerola (2011), investigating the association between the basic feelings expressed by music show a strong correlation between enjoying happy tunes and agreeableness and extraversion, whereas openness was found to have positive correlation with music entailing tension and sadness. Agreeableness also was found to have negative correlation with angry and stressful tunes.

Taking into account the fact that agreeableness refers to tendencies such as avoiding conflict, easy-going, compassion, and cooperativeness, the studies on the use of music have arguably led to striking observations. For instance, Getz, Marks and Roy (2014) analyzed the existence of correlation between the music listening motivations and the music genre preferences of the individuals, with reference to their stress levels, optimism levels, and music education they received. Their results show that music was used for regulating emotions at higher levels of stress. In addition, optimists were found to have a rather emotional interest in music, while a negative correlation exhibited itself between stress and optimism. On the other hand, the participants with more extensive music education, in general, were found to have higher levels of stress and lower levels of optimism. Individuals who received music education had been inclined to listening on rather cognitive grounds in terms of regulating emotions, and had a higher preference for complex and intensive/rebellious music. Generally speaking, individuals with higher levels of stress were found to be inclined to using music for mostly regulating emotions, and to have a preference for optimistic/traditional genres of music. Individuals with higher levels of optimism, on the other hand, had a preference for active and traditional music (quoted by Erdal, Kindaptepe: 2017).

Chen, Liu and Yang's (2015) study found that the individuals who are deemed agreeable and open to new experiences were more into the genre and emotion of music, whereas individuals with high levels of conscientiousness scored emotion higher. On the other hand, the individuals with higher levels of agreeableness and openness were observed to prefer songs with lyrics compared to individuals characterized by neuroticism.

Chamorro-Premuzic et al. claim that agreeableness or conscientiousness is not associated with the use of music on a conceptual level. With reference to other character traits, Chamorro-Premuzic, Swami and Cermakova (2012) found positive correlation between extraversion and the use of music in the background. Openness to new experiences was found to have positive correlation with the cognitive use of music, aesthetic concerns, intellectual curiosity, and individual differences. It should be clear by now that, the existing literature underlines a correlation between agreeableness personality trait and preference for folk music and –to a certain extent– pop music. Moreover, individuals higher levels of agreeableness have a preference for happier tunes, compared to music marked by stress or fear. Yet, any review of the findings of such studies should take into account the prevalence levels of the other four major character traits as well, in addition to the agreeableness scores of the individuals. In other words, in addition to agreeableness, combinations of other character traits, namely neuroticism, openness, conscientiousness, and extraversion or intraversion are most likely to play a role in determining the genres preferred. One should not forget that a review based on agreeableness alone would be inadequate. In the light of the findings discussed above, the following research questions were formulated:

1. Do the agreeableness scores of the students vary by their gender?
2. Do the genres of music the students have been listening before their enrollment in the university, and the foreign languages they speak, write, and listen exhibit any inherent interrelationship structures?
3. Is there a relationship between the musical preferences and agreeableness levels of the students?
4. Is there a correlation between the American and Turkish music genres the participating students listen, and their foreign language proficiency levels?

5. Is there a relationship between the foreign language proficiency of the students, and the sub-dimensions of the agreeableness personality trait?

6. Is there a correlation between the music genres the students were interested in before and during their tenure at the university, and the sub-dimensions of agreeableness?

7. Do the students' preferred music genres change as they proceed from pre-university years to their actual studies at the university?

8. Does a change occur with respect to the list of music genres the students are interested in, as they proceed from pre-university years to their actual studies at the university?

9. Do the knowledge the students acquire about music history and theory vary as they proceed from pre-university years to their actual studies at the university?

10. Is there a correlation between music-related preferences (listening or interest in music, efforts to learn about the history and theory of music) and agreeableness personality trait?

11. Is there a correlation between the music genre the students play currently and agreeableness personality trait?

12. Does the preferred music genre and the agreeableness personality trait vary with reference to the type of school the student is enrolled in?

### **Methodology**

In the present study, the Music Listening Variety and Language Experience Survey developed by the authors, as well as the agreeableness part of the NEO-PR-I scale were employed for this study.

### **Sample and Implementation**

A total of 237 enrolled in music departments of various universities in Turkey took part in the study. 126 of the participants (51.6%) are female, and 111 (45.5%) are male. The participating students were in the age range 17-32, with an average age of 21.49 ( $S=2.94$ ).

### **Data Gathering Tools**

From 1960s to early 1990s, roughly a dozen of researchers from a number of countries had employed factor analysis to identify correlations between various trait descriptions. Virtually squaring a circle, the researchers reduced the list composed of 35 distinctive traits, to 5 ones serving as the basis of the five factors of personality model (Burger, 2004).

These five major traits are openness, conscientiousness, extraversion, agreeableness, and neuroticism. McCrae and Costa define these five traits as follows:

Openness: dreamer vs. realist, variety vs. banality, independent vs. submissive. Conscientiousness: tidy vs. untidy, careful vs. careless, resolute vs. weak-minded. Extraversion: outgoing vs. shy, frolicsome vs. serious, affectionate vs. distanced. Agreeableness: humane vs. tough, trusting vs. doubting, helpful vs. non-cooperative. Neuroticism: anxious vs. cool, insecure vs. confident, self-pity vs. comfortable (McCrae and Costa, 1986b).

These five major traits identified by McCrae et al. have six sub-dimensions each. The sub-dimensions of the agreeableness trait covered by the present study are imagination, emotional disposition, aesthetic disposition, openness to experiences, intellectual curiosity, and open-mindedness. The openness sub-dimension discussed herein refers to openness to experiences rather than assuming an open outlook in interpersonal relations. Among the traits which comprise this sub-dimension, one can think of a strong imagination, the willingness to embrace new views, sophisticated thought, and intellectual curiosity.

According to Feist, individuals who score high in the openness dimension have unconventional and independent thinking. Those who score lower in openness, on the other hand, are rather orthodox, and prefer existing knowledge to learning new things. Taking this definition into account, we can assume that innovative scientists and creative artists score higher in terms of openness (Feist, 1998).

A large number of studies investigated whether personality traits were hereditary or not. In one such study, Bouchard & Loehlin (2001) found that the personality traits are hereditary at a rate of roughly 40-50%, while environmental factors have a further 50% impact. With reference to these findings, one can forcefully argue that the personality traits can be shaped by environmental factors,

and thus the genre of music one is exposed to, as discussed in the present study, can play a role (Bouchard & Loehlin, 2001).

A Ph.D. dissertation on the relationship between music experience and personality traits investigated the potential correlation between the personality traits of the adult students enrolled in an instrumental music program, and their interest in music. The correlation between the music listening preferences of the students and five major personality traits, between their music preferences and five major personality traits, and between such personality traits and many more dimensions concerning music were discussed in that Ph.D. dissertation (Griffith, 2006).

The literature is certainly rich in terms of studies with a similar focus. As was the case with Griffith's dissertation, Payne also investigated the correlation between the personality traits of the orchestra students enrolled in public schools, and their tone preferences and instrument choices (Payne, 2009).

Rentfrow and Gosling's study is about the correlation between personality and music preferences. In doing so, they took multiple samples, trying to understand the relationship between openness to new experiences, and 4 aspects of musical preferences, with reference to specific geographic regions (Rentfrow, Peter J. & Gosling, Samuel D, 2003).

In another study on musical preferences and personality traits, Dollinger investigated the relationship between extraversion, seeking excitement, or openness personality traits, and the musical preferences. Dollinger used NEO personality inventory in his study, and found that extraversion had a positive correlation with Jazz among other musical genres (Dollinger, 1993).

In an article on the personality traits of professional music education students, Jale (1997) found that compared to male students, female ones scored higher in Performance, Dominance, Relationships with the Other Sex, Vanity, Readiness to Consult sub-scales of ACL (Adjective Check List), but lower in Change, Blaming Oneself, Auto-control, and Feminine Characteristics sub-scales.

## Findings

### 1. Do the students' agreeableness scores vary by gender?

One-way MANOVA was applied to determine if the study participant university students' agreeableness personality trait and sub-dimensions thereof varied by gender or not. The analysis did not reveal a significant effect of gender on the agreeableness personality trait and its sub-dimensions [Wilks'  $\lambda = .96$ ;  $F(6, 230) = 1.47$ ,  $p > .05$ ,  $\eta^2 = .03$ ].

Table 1.

*Gender-Based Distribution of the Agreeableness Personality Trait of the Students Who Took Part in the Study*

Variables	Gender	Ave.	S	N
Trust	Female	3.05	.55	126
	Male	3.03	.48	111
	Total	3.04	.52	237
Righteousness	Female	3.88	.59	126
	Male	3.68	.57	111
	Total	3.79	.59	237
Altruist	Female	4.24	.53	126
	Male	4.09	.56	111
	Total	4.17	.55	237
Conformity	Female	2.82	.70	126
	Male	2.80	.65	111
	Total	2.81	.68	237
Tender-minded	Female	3.71	.50	126
	Male	3.66	.51	111

## Turkish University Students' Varied Musical Experiences Agreeableness Levels

	Total	3.69	.51	237
Modest	Female	2.82	.70	126
	Male	2.80	.65	111
Overall Agreeableness	Total	2.81	.68	237
	Female	3.42	.35	126
	Male	3.35	.35	111
	Total	3.39	.35	237

## 2. Do the musical preferences the students had before enrollment in the university, and their foreign language proficiency levels exhibit some kind of correlation?

The principal components were analyzed to determine if the genres of music the students had been listening to prior to their enrollment in the university, and the foreign language they were proficient in, in terms of speaking, writing, listening and reading exhibited some kind of structure or correlation or not. Kaiser-Meyer-Olkin (KMO) value was calculated to see if the data was suitable for analysis. A KMO value of 0.81 was obtained, leading to the conclusion that the data is suitable for principal components analysis. The analysis led to the identification of three factors with an eigenvalue higher than 1. The factors' eigenvalues were 3.57, 1.62, and 1.30. As a result of the analysis based on the varimax rotation technique, the items were found to gather in groups to represent the three factors involved. The factor loads obtained through the analysis are presented in Table 2.

Table 2.

*Results of factor analysis performed for music listening preferences prior to university enrollment, and foreign language proficiency*

Variables	Factor 1	Factor 2	Factor 3
Reading proficiency	.84	.12	-.04
Writing	.82	.10	.02
Foreign language proficiency	.78	.04	-.01
Speaking	.76	.10	-.04
Listening	.70	.33	-.06
American folk music	.08	.81	.04
American country music	.28	.79	.05
Classical music	.08	.67	.02
Classical Turkish music	.03	.06	.73
Turkish folk music	-.05	-.08	.68
Turkish pop music	-.05	.11	.67
Eigenvalue	4.09	2.69	1.44
Variance expressed	34.08	22.41	12.00

## 3. Is there a correlation between the musical preferences the students had prior to their enrollment in the university, and the agreeableness personality trait?

The factor analysis produced the overall scores for listening foreign (American) and Turkish music. Pearson correlation coefficients were assessed to analyze any correlation between the agreeableness personality trait's sub-dimensions, and the overall scores for listening American music and Turkish music (see Table 3). The analysis revealed that listening American music genres among the students was not correlated with sub-dimensions of the agreeableness personality trait, while listening Turkish music had a positive correlation with the sub-dimensions of that personality trait.

Table 3.  
*Correlations between the research variables*

	1	2	3	4	5	6	7
1. Listening American music	-						
1. Listening Turkish music	-.05	-					
3. Trust	-.01	.49**	-				
4. Straightforwardness	-.06	.56**	.02	-			
5. Altruism	-.11	.51**	.15*	.43**	-		
6. Compliance	-.03	.75**	.22**	.17**	.012	-	
7. Tender-minded	.04	.46**	.19**	.13*	.36**	.08	-
8. Modesty	-.03	.28***	.12	.22***	.15**	.11	.36***

#### 4. Is there a correlation between the musical preferences and foreign language proficiency levels of the students?

The correlation between the foreign language proficiency levels and the American and Turkish music genre they listened was analyzed using Pearson correlation factors (see Table 4). In conclusion, it was observed that a positive correlation existed between listening American music and foreign language speaking, reading, writing and listening skills, but no such correlation existed with listening Turkish music.

Table 4.  
*Correlations between the research variables*

	1	2	3	4	5	6
1. Listening American music	-					
1. Listening Turkish music	.08	-				
3. Foreign language speaking	.22***	-.03	-			
4. Foreign language reading	.28***	-.06	.58***	-		
5. Foreign language listening	.39***	-.05	.44***	.53***	-	
6. Foreign language writing	.25***	-.02	.56***	.65***	.52***	-
7. Foreign language proficiency level	.23***	-.05	.46***	.55***	.54***	.50***

#### 5. Is there a correlation between the foreign language proficiency levels of the students, and the agreeableness personality trait?

The correlation between the foreign language proficiency levels of the students who took part in the study, and the sub-dimensions of the agreeableness personality trait were reviewed by assessing correlation factors (see Table 5). In conclusion, negative correlations between straightforwardness and altruism traits and foreign language listening proficiency, and between altruism and foreign language proficiency levels were observed.

## Turkish University Students' Varied Musical Experiences Agreeableness Levels

Table 5.  
Correlations between the research variables

	1	2	3	4	5	6	7	8	9	10	11
1. Foreign language speaking											
2. Foreign language reading	.58***	-									
3. Foreign language listening	.44***	.53***	-								
4. Foreign language writing	.56***	.65***	.52***	-							
5. Foreign language proficiency level	.46***	.55***	.54***	.50***	-						
6. Trust*	-.03	-.01	.03	-.01	.03	-					
7. Straightforwardness*	-.06	-.18**	-.16***	-.07	-.09	.02	-				
8. Altruism	-.06	-.09	-.15***	-.09	.15**	.15**	.42***	-			
9. Compliance	.05	.02	.01	.01	.05	.22***	.17**	.01	-		
10. Tender-minded	-.04	-.05	-.12	-.09	-.12	.19***	.13*	.36***	.08	-	
11. Modest	-.04	-.06	-.95	-.01	-.01	.12	.22***	.15**	.11	.31***	-
12. Total agreeableness score	-.02	-.08	-.10	-.06	-.06	.49***	.56***	.51***	.75***	.46***	.28***

### 6. The analysis of the correlation between the music genres the students want to learn about through their university education, and the sub-dimensions of agreeableness

The analysis of the correlation between the music genres the students want to learn about through their university education, and the sub-dimensions of agreeableness was performed using Pearson correlation factors (see Table 6). A positive correlation was found between Turkish music genre the student was interested in before enrollment in the university, and modesty as a personality trait.

Table 6.  
Correlations between the research variables

	BE American Music Genre	BE Turkish Music Genre	UE American Music Genre	UE Turkish Music Genre
3. Trust	-.01	-.03	-.06	-.10
4. Straightforwardness	.01	-.02	-.02	-.06
5. Altruism	-.02	.02	-.06	-.01
6. Compliance	.02	-.09	-.09	-.04
7. Tender-minded	.03	-.01	-.07	-.01
8. Modesty	.07	.13*	-.06	-.01

Note. BE: Before Enrollment, UE: University Education

\* $p < .05$ , \*\* $p < .01$ , \*\*\* $p < .001$ .

### 7. Does a change happen with the music genres the students listen through their enrollment in the university?

Matched-pair t-testing was applied to see if any change occurred with respect to the music genres the students listen through their enrollment in the university (see Table 7). In conclusion, it was observed that no significant change occurred with respect to the American music genre the students listened

through the enrollment  $t(243) = -.06, p > .05$ ; yet, that students listened a higher amount of Turkish music before their enrollment in university  $t(243) = 4.58, p < .001$ .

Table 7.

*Average values and standard deviation figures for music genres*

	<i>Average</i>	<i>S</i>
BE American Music Genre	.28	.33
AE American Music Genre	.28	.30
BE Turkish Music Genre	.63	.33
AE Turkish Music Genre	.50	.38

*Note.* BE: Before Enrollment, AE: After Enrollment

### 8. Does a change happen with the music genres the students want to learn about through their enrollment in the university?

Matched-pair t-testing was applied to see if any change occurred with respect to the music genres the students want to learn about, through their enrollment in the university (see Table 8). In conclusion, it was found that the average values for the American music genre an  $t(243) = .84, p > .05$  and Turkish music genre  $t(243) = .33, p > .05$  the students wanted to learn about before and after their enrollment in the university did not undergo any significant change through the process.

Table 8.

*Average values and standard deviation figures for music genres*

	<i>Average</i>	<i>S</i>
BE American Music Genre	.23	.28
AE American Music Genre	.25	.27
BE Turkish Music Genre	.34	.31
AE Turkish Music Genre	.35	.31

*Note.* BE: Before Enrollment, UE: University Education

### 9. Does a change happen with the music genres the students study the history and theory of through their enrollment in the university?

Matched-pair t-testing was applied to see if any change occurred with respect to the knowledge students gather about the history and theory of music through their enrollment in the university (see Table 9). In conclusion, it was found that during their studies at the university the students commanded a larger volume of knowledge about the history and theory of American ( $t(243) = -4.73, p < .001$ ) and Turkish ( $t(243) = -2.64, p < .001$ ) music, compared to their amount of knowledge prior to enrollment.

Table 9.

*Average values and standard deviation figures for music genres*

	<i>Average</i>	<i>S</i>
BE American Music Genre	.16	.22
AE American Music Genre	.26	.23
BE Turkish Music Genre	.29	.30
AE Turkish Music Genre	.36	.32

*Note.* BE: Before Enrollment, UE: University Education

### 10. Are the preferences regarding music (listening, learning about music, learning the history and theory of music) and agreeableness personality trait scores correlated?

The correlation between the music genre the students had listened before and after their enrollment in the university, the music genre they wished to learn more about, and the knowledge students gather about the history and theory of music, with the agreeableness personality trait, were studied using Pearson correlation factor. In conclusion, agreeableness personality trait was not found to be correlated

## Turkish University Students' Varied Musical Experiences Agreeableness Levels

with the music genre the students listened to or were interested to learn about, as well as the knowledge they accumulated about the history and theory of music.

Table 10.  
*Correlations between the research variables*

Variables	1	2	3	4	5	6	7	8	9	10	11	12	
1. Agreeableness													
2. Learning about American Music BE	.02	1											
3. Learning about Turkish Music BE	-.07	.20** *	1										
4. Learning about American Music UE	-.11	.28** *	.01	1									
5. Learning about Turkish Music UE	-.08	.01	.22** *	.14**	1								
6. Listening American Music BE	-.06	.43** *	-.01	.20** *	-.01	1							
7. Listening Turkish Music BE	-.01	.06	.38** *	.08	-.01	.08	1						
8. Listening American Music UE	-.06	.25** *	.07	.41** *	.20* *	.37** *	.15*	1					
9. Listening Turkish Music UE	-.02	.03	-.04	.12	.43* *	.02	.24** *	.24** *	1				
10. Learning history and theory of Turkish music BE	-.01	.23** *	.47** *	.02	-.06	.10	.29** *	-.01	-.06	1			
12. Learning history and theory of Turkish music UE	-.10	.19** *	.02	.34** *	.39* *	.09	-.10	.24** *	.26** *	-.01	1		
13. Learning history and theory of American music BE	-.03	.44** *	.04	.01	-.05	.44** *	-.03	.08	.02	.25** *	.03	1	
14. Learning history and theory of American music UE	-.02	.21** *	.10	.48** *	.12	.13** *	.09	.33** *	.10	.05	.36** *	.04	1



## Conclusion

The conclusions reached with respect to the research questions presented above are listed below. A glance at the results reached with respect to 12 research questions reveals that the correlations between agreeableness personality trait and listening music, learning about music, and learning the history and theory of music varied with reference to specific variables involved.

A total of 244 enrolled in music departments of various universities in Turkey took part in the study. 126 of the participants (51.6%) are female, and 111 (45.5%) are male. The participating students were in the age range 17-32, with an average age of 21.49 ( $S=2.94$ ). One-way MANOVA was applied to determine if the study participant university students' agreeableness personality trait and sub-dimensions thereof varied by gender or not. The analysis did not reveal a significant effect of gender on the agreeableness personality trait and its sub-dimensions [Wilks'  $\lambda = .96$ ;  $F(6, 230) = 1.47$ ,  $p > .05$ ,  $\eta^2 = .03$ ].

The principal components were analyzed to determine if the genres of music the students had a preference for prior to their enrollment in the university, and the foreign language they were proficient in, in terms of speaking, writing, listening and reading exhibited some kind of structure or correlation or not. Kaiser-Meyer-Olkin (KMO) value was calculated to see if the data was suitable for analysis. A KMO value of 0.81 was obtained, leading to the conclusion that the data is suitable for principal components analysis. The analysis led to the identification of three factors with an eigenvalue higher than 1. The factors' eigenvalues were 3.57, 1.62, and 1.30. As a result of the analysis based on the varimax rotation technique, the items were found to gather in groups to represent the three factors involved.

The factor analysis produced the overall scores for foreign (American) and Turkish music preferences. Pearson correlation coefficients were assessed to analyze any correlation between the agreeableness personality trait's sub-dimensions, and the overall scores for American music and Turkish music preferences. The analysis revealed that preference for American music genres among the students was not correlated with sub-dimensions of the agreeableness personality trait, while preference for Turkish music genres had a positive correlation with the sub-dimensions of that personality trait.

The correlation between the American and Turkish music genres the students who took part in the study had a preference for, and their foreign language proficiency levels were analyzed using Pearson correlation factors. In conclusion, it was observed that a positive correlation existed between preferences for American music and foreign language speaking, reading, writing and listening skills, but no such correlation existed with listening Turkish music.

The correlation between the foreign language proficiency levels of the students who took part in the study, and the sub-dimensions of the agreeableness personality trait were reviewed by assessing correlation factors. In conclusion, negative correlations between straightforwardness and altruism traits and foreign language proficiency, and between altruism and foreign language proficiency levels were observed.

The analysis of the correlation between the music genres the students want to learn about through their university education, and the sub-dimensions of agreeableness was performed using Pearson correlation factors. A positive correlation was found between Turkish music genre the student was interested in before enrollment in the university, and modesty as a personality trait.

Matched-pair t-testing was applied to see if any change occurred with respect to the music genres the students have a preference for through their enrollment in the university. In conclusion, it was observed that no significant change occurred with respect to the American music genre the students had a preference for through the enrollment  $t(243) = -.06$ ,  $p > .05$ ; yet, that students had a preference for a higher amount of Turkish music before their enrollment in university  $t(243) = 4.58$ ,  $p < .001$ .

Matched-pair t-testing was applied to see if any change occurred with respect to the music genres the students want to learn about, through their enrollment in the university. In conclusion, it was found that the average values for the American music genre an  $t(243) = .84$ ,  $p > .05$  and Turkish music genre  $t(243) = .33$ ,  $p > .05$  the students wanted to learn about before and after their enrollment in the university did not undergo any significant change through the process.

Matched-pair t-testing was applied to see if any change occurred with respect to the knowledge students gather about the history and theory of music through their enrollment in the university (see Table 9). In conclusion, it was found that during their studies at the university the students commanded a larger volume of knowledge about the history and theory of American ( $t(243) = -4.73, p < .001$ ) and Turkish ( $t(243) = -2.64, p < .001$ ) music, compared to their amount of knowledge prior to enrollment.

The correlation between the music genre the students had listened before and after their enrollment in the university, the music genre they wished to learn more about, and the knowledge students gather about the history and theory of music, with the agreeableness personality trait, were studied using Pearson correlation factor. In conclusion, agreeableness personality trait was not found to be correlated with the music genre the students listened to or were interested to learn about, as well as the knowledge they accumulated about the history and theory of music.

### Implications

Given the observations of a positive correlation with foreign language proficiency and of the marked preference for Turkish music among the people who are not proficient in foreign language, the students should learn a foreign language if they want to expand the variety of music.

The positive correlation between listening to American music and foreign language speaking, reading, writing and listening, coupled with the lack of association with listening Turkish music, suggests that the students should learn a foreign language (e.g. English, French, German) with not only reading skills, but also with listening, speaking and reading skills.

With reference to the positive correlation between Turkish music genre and modesty personality trait, one can argue that listening Turkish language music is associated with a higher score in modesty, compared to listening foreign language music.

The increased level of knowledge on the history and theory of Turkish music received during their studies at the university compared to the period prior to their enrollment suggests that the curriculum offered to the students of music departments in Turkish universities focuses substantially on information about the history and theory of Turkish music.

The higher weight of Turkish music in the listening repertoire of students enrolled in Cumhuriyet University, Faculty of Education, compared to that of their peers at Istanbul Technical University Conservatory can perhaps be a result of the rather traditionalist outlook the former group has. In contrast, the students enrolled in Istanbul Technical University Conservatory were found to have a more emphasized preference for American music, compared to their peers from Cumhuriyet University, Faculty of Fine Arts, probably due to their residence in a big city.

### References

- Chamorro-Premuzic, T., Swami, V., Cermakova, B. (2012). Individual differences in music consumption are predicted by uses of music and age rather than emotional intelligence, neuroticism, extraversion or openness. *Psychology of Music, 40*, 285–300.
- Chen, P., Liu, J.Y. and Yang, Y. H. (2015). Personal Factors in Music Preference and Similarity: User Study on the Role of Personality Traits. *Proc. Int. Symp. Computer Music Multidisciplinary Research*.
- Delsing M. J. M. H., ter Bogt, F. M. T., Engels, R. C. M. E., and Meeus, W. H. J. (2008). Adolescents' music preferences and personality characteristics. *European Journal of Personality, 22*, 2, 109-130., <https://doi.org/10.1002/per.665>.
- Dollinger, S. J. (1993). Research Note: Personality and Music Preference: Extraversion and Excitement Seeking or Openness to Experience? *Psychology of Music, 21*, 73-77.
- Erdal, B. (2009). Muzik Tercih ve Kisilik Iliskisi. *Cumhuriyet U. Sosyal Bilimler Dergisi, V. 35, Issue 2, 188-196*.
- Erdal, B. and Kindaptepe, Y. (2017). Ruh halinin icedonuk ve disadonuklerde tercih edilen muzige etkisi ve muzigin uyandirdigi duygular uzerine bir arastirma. *The Journal of Academic Social Sciences, 5(59), 54-75.*, <http://dx.doi.org/10.16992/ASOS.13002>.

- Ferwerda, B., Tkalcic, M. and Schedl, M. (2017). Personality Traits and Music Genres: What Do People Prefer to Listen To? In *Proceedings of the 25th Conference on User Modeling, Adaptation and Personalization. ACM*, 285–288.
- Getz, L. M., Marks, S., Roy, M. (2014). The influence of stress, optimism, and music training on music uses and preferences. *Psychology of Music*, 42(1) 71–85. Doi: 0.1177/0305735612456727.
- Greb, F., Schlotz, W. and Steffens, J. (2017). Personal and situational influences on the functions of music listening. *Psychology of Music* <https://doi.org/10.1177/0305735617724883>
- Little, P., Zuckerman, M. (1986). Sensation seeking and music preferences. *Personality and Individual Differences*, 7, 575-577.
- Rentfrow, P.J and Gosling, S. D. (2003). The do re mi's of everyday life: The structure and personality correlates of music preferences. *Journal of personality and social psychology* 84, 6, 1236.
- Tekman, H. G. (2009). Music preferences as signs of who we are: Personality and social factors. *Proceedings of the 7th Triennial Conference of European Society for the Cognitive Sciences of Music (ESCOM 2009)* Jyväskylä, Finland.
- Vuoskoski, J., Eerola, T. (2011). The role of mood and personality in the perception of emotions represented by music. *Cortex*, 47, 1099-1106 Doi:10.1016/j.cortex.2011.04.011

# The All- Inclusive Process and Children With Severe Disabilities

Elmira Rama

## 1. Introduction

The inclusion movement is an international trend being explored in many countries (Mittler, 2000). In 1994, the United Nations Educational, Scientific and Cultural Organization (UNESCO) organized the Salamanca Conference where 94 countries participated in the development of the Salamanca Declaration and Framework for Action. This declaration states "inclusion and participation are essential to human dignity and to the enjoyment and exercise of human rights" (p. 17). The discussion for education of children with disabilities begins with the treatment that is done today the issue from the perspective of guaranteeing basic human rights (UN, 1948). Expanding the concept of education for children with disabilities is closely related to the all- inclusive process to education . "Every child has the right of education" - noted in the statement of Salamanca. The principle of inclusive education should be involved as a law or policy, recognizing all children in normal schools, in addition to barriers to force greater. (Unesco, 1994) The notion of inclusion affirms the importance of including all students in creating a really school welcoming, even through the changes of lesson curriculum and organizational strategies, which should be sensitive to the full promotion of the differences that exist among students. (Dovigo, 2007). In determination of the UNESCO (UNESCO, 2003) the inclusive education is defined as a process that addresses and responds to the diverse needs of all learners through increasing participation in learning and reduce exclusion in and through him. Promoting inclusive education in Albania is mainly carried out through: (1) direct support to children with disabilities in inclusion and education at public schools; identification, registration and daily support through the development and implementation of Individual Education Plans (IEP) (2) Increasing the capacity of teachers, parents, education specialists at the Regional Educational Directorates (RED) and school psychologists about Inclusive Education issues. (3) Awareness activities, extended to selected schools and kindergartens, and not only, in the surrounding community, in relation to the rights of children with disabilities for inclusive and quality education. ( "Save the Children",2013)

The Albanian legal framework guarantees the right for educate every child, regardless of their needs and abilities. The Constitution of the Republic of Albania, in its Article 57, provides for the equal right of all citizens to be educated, as well as Article 59 the right to specialized education and the integration into society of people with disabilities.

Approval of the new Law 69/2012 "For the Pre-university Education" marked an important step for the right of persons with disabilities for education.

Article 2 defines "Students with disabilities are those who have long-term physical, mental, sensory, behavioral or combined which, in interaction, can inhibit participate fully and equally in his education and social life ".

Article 5 "The right to Educate ", cites : "In the Republic of Albania guarantees the right to educate of Albanian citizens, foreigners and stateless persons without discrimination from gender, race, color, ethnicity, language, sexual orientation, political or religious beliefs, status economic or social origin, age, place of residence, disability or other reasons defined in the Albanian legislation ".

In the article 63 cited : Inclusion of children with disabilities to specialized educational institutions for them is generally temporary. The inclusion and integration of children with disabilities in kindergartens and schools of basic education is a priority. "But anyway, this process faces in same barriers for children with severe disabilities, such as lack of infrastructure in mainstream schools and the reluctance of parents to enroll in mainstream schools because of prejudice.

There are also barriers that have to do with the child's disability, its severity, and its behavior coming as a function of the disabilities and lack of the teachers' abilities to respond to these behaviors. But as the studies show, these barriers are often used for certain directions necessary for intervention

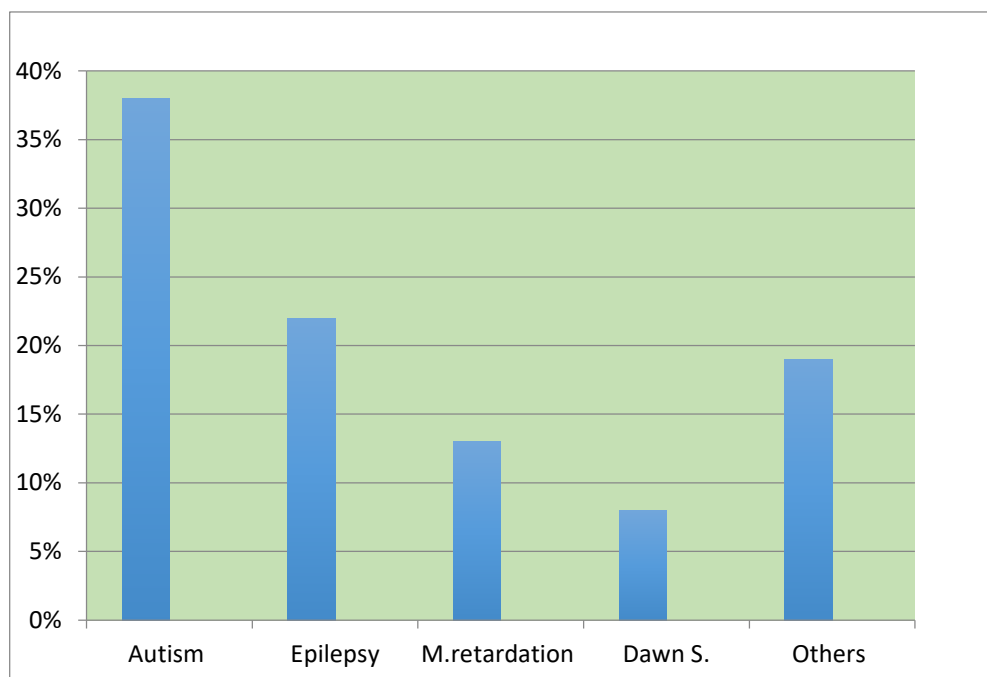
.(Institute of Medicine, National Academies, 2007, p.165). National Information Center for Children and Youth with Disabilities (NICHCY) has defined people with severe disabilities "who are traditionally labeled as mental retardation heavy and deep "who" require constant and extensive support in more than one vital activity to participate in integrated community environments and to enjoy the quality of life available to people with less or no disabilities ". Through collaborative partnerships and teamwork Family, children with limited abilities to multiple or severe, can achieve meaningful results. Educators need to understand that although these children may present substantial educational challenge, they deserve the right to grow, to learn and to advance, like everyone else. (EM Hornand J. Kang 2012)

### **1.1 History of Special Education in Albania and in the district of Fier.**

Institutionalized treatment of children with disabilities in Albania was launched in 1963, when the Institute of blind and deaf students was opened. The centralized model of government until years' 90, portrayed as in every other aspect of life in Albania, also in special education, the institutions established and provide care. Later, in the "70th" are opened 80 special education schools for children with mild mental retardation in Tirana, Shkodra, Durres, Elbasan, Korca and Vlora, whereas in "90 are opened three day care centers in Shkodra, Librazhd, Lezha for children with severe mental retardation (Nano. V, 2002). The first attempts at authentic integration practices in Albania concern the years "90 (Study on the integration of children with disabilities in traditional schools: "Albanian School for integration processes", 2002, p. 8). In the district of Fier, day center "Dea" - an NGO, (non-governmental organization) supported by private raised since 2010 of June, was the only day care centers which accommodate about 25 children with disabilities, by offering them professional assistance to individual programs. This center has had three specialized social workers, tutors and other support staff. Total in this center work ten employees. Because this center was the only provider of such services in Fier, complementing in this way a empty space in the field of social services, support by the local government in the form of financing has been a necessity. Special Class, a class created at the school "Liri Gero" profiled in providing special education to various disability categories, actually has a function as a day care center because they do not meet the criteria to be classified as a special education school. The problems that faced this class were various, such as the transportation of children who come from the rural areas, to the didactic tools of the environmental conditions in which to learn. The teachers of this school were very committed to children but lack of methodical materials has made this class do not be properly functional . (SZHPAK Fier ,2010 p.24)

From a 2016 study, "Report on disability in the territory of Fier " result 3. 497 persons with disabilities of which 1638 belong to the age 6-18. With the opening of multifunctional social center in September 2015, 60 of them, never without the prior specialized social services, was presented at this center to be treated. All were mainly with severe and multiple caused by Autism, Epilepsy (associated with behavioral problems and emotional type) Dawn syndrome, mental retardation and others.

## The All- Inclusive Process and Children With Severe Disabilities



Graph.1 Diagnosis

Although a relatively small group, is it right that children with severe or multiple to be excluded from the educational system? The overall goal of this study is to reveal the social service specialized role for a integration and inclusion education without exclusion. In order to achieve that goal have raised the following questions: How does social service specializing impact on the integration and inclusion of children with severe disabilities? Wich factors are involved in a combined intensive intervention efficiently? The importance of this study is in the fact that the Albanian academic literature has begun to give importance prevail studies for the education of children with disabilities, but little is said about the category of children with severe and multiple. The study estimates that alternating work wreathed therapeutic - edukative for reducing child with severe problems, identifying factors that help an intensive intervention efficiently. This article is as much a study as evidence both parents and educators of children with disabilities.

## 2. Method

The study is descriptive survey method with the participation, at social service specializing in the multifunctional center "Horizon" of the Fier District. This center on the vew point of organization can be considered as an example of a transversal work, educational and therapeutic, where teachers and specialists collaborate in groups with the aim to design of the intervention and its implementation through specific strategies. In this social center I have given contribution as a biolog nutritionist and as a teacher, being in cooperation with specialists, in direct conversations with parents and on the observational work with children with severe disabilities on treatment in this center. This paper was discussed and approved by the multidisciplinary committee of the center and the parents' council.

### 2.1 Description Of The Work

In the rehabilitation and health field has considerable changes that alter the axis of an individual biomedical perspective on what Biopsychosocial, in interaction with the context of life, as proposed by the International Classification of Functioning Disability and Health (WHO, 2001, 2007) . Through the interconnection of many perspectives, ICF (International Classification of Functioning) describes the global functioning of the subject, his health, and / or his difficulties in the field of education, learning, in order to identify interventions to be carried out to allow reached the maximum of its realization. (Peterson, Enskar, Huus & Simeonsson, 2013). Near center, in which the study was conducted, is set

up multidisciplinary committee who decides to enroll after examining the documentation of the child, parent interviewed and observed the child at the same times the premises of the center. In this way, is determined the functional diagnosis of the child, which is nothing more than an assessment of health problems by rehabilitation specialists. Functional Diagnosis Based on ICDH (International Classification of Impairments, Disabilities, and Handicaps) was evaluated in a series of studies on physical therapy, exercise therapy, vocational therapy, and speech therapy. The results have shown that the functional diagnosis tends to be reliable; the treatment goals stemming from the diagnosis, provide a significant characterization given by rehabilitation specialists care; and that the available treatment goals predict the selection of interventions by rehabilitation specialists. (J. Dekker 2009) Dynamic Functional Profile is the second intervention instrument. Built by teachers and professional therapists observing and keeping specific records for the child's abilities and needs during a two-week period, including information from parents. The Dynamic Functional Profile evidences the child's abilities and needs in this way becoming the leader in the design of the intervention. The Individual Educational Plan is the document that contains the intervention project in three areas: rehabilitation, socialization, education. Regarding rehabilitation, therapies are developed by psychologists, speech therapists and physiotherapists. Therapies developed according to schedule alternate with teaching process based on the child's needs and problems. Also it has a specific program for the development labs and organized a series of activities aiming at the socialization of children. The teaching process takes place in separate special classes, divided by age group. Activity in the classroom is developed by adopting the general framework of teaching based on the needs of children and difficulties in achieving the Individual Education Plan goals. Those are still rare studies that describe the results of the activities target children about the learning process in the presence of a disability. (E. Malaguti, 2017) American neuroscientist, expert at dyslexia, Maryanne Wolf (2012) in a study devoted to reading, says no specific genes loaded solely to enable the human being to read and write. To win this capacity, not only natural, children need environments education, supporting connection (structures related to vision and speech) of all those circuits that need an acquisition to allow the brain to read. Therefore, one of the main methods of teaching is the use of practical activities and visual aids tools.



**Figure 1 Rehabilitation**



**Figure 2 Socialization**



**Figure 3 The education process**



## 2.2. Nutrition .

Balanced food is essential during childhood to support normal growth and cognitive development. When children are fed with unhealthy foods, certain behavioral problems can begin to arise. Among the most common of these are attention deficit hyperactive disorder, irritability and aggression. Poor diets that are high in sugar, fast food, artificial food additives and trans fats have been studied for their potential links effects to these behavioral issues (Clay mcnight 2017) Nutrient composition and meal pattern can exert immediate or long-term, beneficial or adverse effects. Beneficial effects mainly result from the correction of poor nutritional status. One aspect of diet that has elicited much research in young people is the intake/omission of breakfast. This has obvious relevance to school performance. While effects are inconsistent in well-nourished children, breakfast omission deteriorates mental performance in malnourished children. Overall, the literature suggests that good regular dietary habits are the best way to ensure optimal mental and behavioural performance at all times. (Bellisle F1. 2004) Children at the center, consume breakfast and lunch, then take there about 60% of the calories needed. Meal consumption is not only nutritional character, but also educational and experimental. Nutritional referral in the diet is a model of the Mediterranean diet. In addition to the positive models, the motivation of children who present problems with anorexia or with food selections, by form and color of the food has given noticeable effects.

## 2.3 Cooperation with parents.

In promoting the achievements at all levels of primary and secondary schools, emphasized the important role of families, family-school relationships and involvement in education parents. (Hill & Tyson 2009) Parental involvement, in almost any form, produces measurable gains in student achievement" (Dixon, 1992, p. 16). The concept of parental involvement with the student and the school is a vital one and can produce great rewards for all concerned. However, it has been found that schools do not always know what the term parental involvement really means (Vandergrift & Greene, 1992). The visit of parent in center is a practice developed for known parent closely with efficient strategies for their child. Notebook of communication has been a way of communication for exchange of information daily mutual family-institution.



**Figure 4. The adaptation process in the normal schools**

After a positive evaluation by continuous monitoring of the child's progress starts the adaptation process in normal schools. Once noticed familiarity with the structure of the child and hospitality by his peers, with the approval of the parent, Multidisciplinary Commission of the center, proposed to the Multidisciplinary Commission Directorate Educational for evaluation of the documentation and the child, who then decide on his inclusion in the normal school and additional service from the supportive teacher.

## Discussion and conclusion.

Inclusive education removes the practice of separating students with learning and / or physical challenges from the rest of the student body. While the practice of including additional requirements for students and logistics facilities, there are numerous benefits to all students with disabilities as well

as disability. (Guest Blogger ,2015) Educating students with severe intellectual limitations and multiple poses different challenges for the practitioners, families and politicmakers. These challenges are complex philosophical and ethical, and influencing the curriculum, assessment and pedagogy. (Lyons, G., & Arthur-Kelly, M. 2014). The regional Department of Education in cooperation with the “Horizont” day care centre and many other local public schools have managed to bring major changes as far as concerning the involvement of the person with disabilities.(A. Osmani ,2016 p. 68) Until now resulting involved in normal schools in Fier 12 children with severe, previously treated in the “Horizont” Day care centre. Number this, realize in a short period of time and it gives hope to increase continuously. Intensive intervention helps children with severe needs and continuous learning and behavior, including students with disabilities. (NCII 2015). Children and adolescents with deep disabilities intellectual and multiple depend on the support they receive through their environment. Identified strategies, tailored individually through awareness and knowledge from parents and personal assistants, provide important evidence to help our understanding, to understand how to improve participation in family activities of children and adolescents with deep disabilities intellectual and multiple (PIMD) (Axelsson CA1, Imms C, Wilder J. *Disabil Rehabil.* 2014) The observations reported in this study clearly spell out that social service specializing ensure the implementation of a combined intensive intervention plan, which gives the opportunity a child for the cognitive and functional development ,simultaneously. The working group model teacher-specialists , care for specific nutritional needs and cooperation with parents, are factors affecting mitigation and reducing problems of child with severe disabilities.Treatment of children in specialized social centers can be considered as a strategy to qualitative integrate and inclusion education. Inclusive education, the axis moves from a perspective that relates to the individual child and its limitation in that provides a global vision as well as their full participation in the context of real life (Stiker, 2009).

### **Recommendation**

Social service specializing should work for children with severe or multiple, because the centers of this kind are provided with a service of special teachers and therapists specializing profession. In addition, specialized teachers can give support to other teachers at normal schools as resource teachers, thus creating a positive relationship between special and mainstream schools centers. This relationship helps inclusive education.

### **Referenze**

- A. Osmani, (2016) Report on disability in the territory of Fier.  
 Axelsson AK<sup>1</sup>, Imms C, Wilder J. *Disabil Rehabil.* 2014;Strategies that facilitate participation in family activities of children and adolescents with profound intellectual and multiple disabilities: parents' and personal assistants' experiences. 36(25):2169-77. doi: 10.3109/09638288.2014.895058. Epub 2014 Mar 4.  
 Dixon, A. (1992, April). Parents: Full partners in the decision-making process. *NASSP Bulletin*, 76(543), 15-18  
 Dovigo F. (2017) Making differences: indicators for the inclusion of pupils with special educational needs. Erickson Trento.  
 Bellisle F1. Effects of diet on behaviour and cognition in children.. Retrieved from: <https://www.ncbi.nlm.nih.gov/pubmed/15522161>  
 Elena Malagutias (2017) Inclusive early childhood education and right of literacy even for children with disabilities. *Form@re - Open Journal per la formazione in rete* ISSN 1825-7321, vol. 17, n. 2, pp. 101-112  
 Guest Blogger The biggest barriers to inclusive education 2015. Retrieved from: <https://www.thinkinclusive.us/barriers-to-inclusive-education/>  
 Hill, N. E., & Tyson, D. F. (2009). Parental involvement in middle school: A meta-analytic assessment of the strategies that promote achievement. *Developmental Psychology*, 45(3), 740–763  
 How Diet Affects Children's Behavior By clay mcnight oct. 03, 2017 Retrieved from: <https://www.livestrong.com › Food and Drink>

- J. Dekker (2009) Application of the ICIDH in survey research on rehabilitation: the emergence of the functional diagnosis, *Disability and Rehabilitation*, 17:3-4, 195-201
- Lyons, G., & Arthur-Kelly, M. (2014). UNESCO Inclusion Policy and the Education of School Students with profound Intellectual and Multiple Disabilities: Where to Now? *Creative Education*, 5, 445-456.
- Mittler, P. (2000). *Working towards inclusive education: Social contexts*. London: David Fulton Publishers.
- Nano.V. (2002) Study on the integration of children with disabilities in mainstream schools: "Albanian School for Integration Processes", National Dissemination Center for Children with Disabilities (NICHCY) 2001 Severe and/or multiple Disabilities. Fakt sheet #10
- National Center on Intensive Intervention (NCII)(2015 a) Retrieved from: <https://intensiveintervention.org/intensive-intervention>
- Parliament of the Republic of Albania,(1998) Constitution of the Republic of Albania.
- Peterson, C., Enskar, K., Huus, K., & Simeonsson, R.J. (2013). Comparing HRQOL instruments for children within the framework of the ICF -CY. *Health and Quality of Life Outcomes*. 11:75 doi: 10.1186/1479-7525-11-75.
- Save the children (2013); *Inclusive education in Albania*.
- Stiker, H.J. (2009). *Les métamorphoses du handicap de 1970 à nos jours*. Grenoble: PUG.
- The Assembly of the Republic of Albania, Law no. 69/2012 "On the pre-university education system in the Republic of Albania". (2012)
- The state social service; UNFPA. *Development Strategy for people with disabilities in the region of Fier*. Nentor 2010.
- UNESCO (1994) *The Salamanca Statement and Framework for Action on Special Needs Education*. Adopted by the World Conference on Special Needs Education: Access and Quality, Salamanca, Spain, 7-10 June 1994
- Vandergrift, J., & Greene, A. (1992, September). Rethinking parent involvement. *Educational Leadership*, 50(1), 57-59
- Washington (DC): National Academies Press (US); 2007. *The National Academies Collection: Reports funded by National Institutes of Health*.
- WHO. World Health Organization. (2001). *International Classification of Functioning, Disability and Health: ICF*. Geneva: World Health Organization.
- WHO. World Health Organization. (2007). *International Classification of Functioning, Disability, and Health: Children & Youth Version: ICF-CY*. Geneva: World Health Organization.

# **A Research On Teachers' Liking Of Children And Children's Feelings About School, Opinions About Teacher And Perceptions About Their Academic Skills**

Ayşe Oztürk Samur, Gozde Inal Kiziltepe, Esra Angin

## **1. Introduction**

Teachers who are the initiators, developers, and practitioners of training services are the most important building blocks of an effective and efficient education process. Thus, the implementations administered to promote the quality of training services mostly focus on the qualities required for the teachers. In addition to teachers' professional competences related to their fields of interest, one of the most important teacher qualities is liking of children (Saracho & Spodek, 2007; Duyan & Gelbal 2008; Kok, Ciftci & Ayik, 2011; Erdogan & Cuceloglu, 2013; Mete, 2013; Bag & Ceviker Ay, 2017). Today, liking of children are one of the priorities for those who will choose teaching as profession and also the quality of liking of children has been adopted as one of the qualities of effective teachers (Brown, Morehead & Smith, 2008; Gelbal & Duyan, 2010).

Liking of children which is described as individual's basic beliefs and favourable attitudes towards and being with children (Barnett & Sinisi, 1990) is one of the most important elements of a high quality and successful education (Lasley, 1980; Veenman, 1984, Yoleri, 2014). Brown, Morehead, & Smith (2008) stated that loving children is an important condition for those who are going to choose teaching as profession. In addition, Gelbal & Duyan (2010) stress that liking of children is the most important variable to work with children. Marso & Pigge (1994) determined that the most important variable liking of children before deciding to become a teacher. Downing, Ryndak, & Clark (2000) indicated that in addition to qualities like being patient, caring and kind, calm, and being able to interact with children, loving children is an important quality required to be an effective educator. Ergun & Ozdas (1999) stated that liking of children facilitated class management and also made the education process more enjoyable. Moreover, it is considered that teachers who love children understand children's feelings and desires and get more attentive while talking and listening to children (Durmusoglu Saltali & Erbay, 2013). Thus, it is regarded that this situation will have an effect on teachers' attitudes and behaviors towards children (Ergun & Ozdas, 1999) and it will develop a quality teacher- child interactions. The quality teacher -child interactions can be defined as the higher levels of proximity and lower levels of conflict between the teacher and the child (O'Connor & McCartney, 2006). This teacher-child relationship quality is one of the most important variables that affect child's readiness to school, adaptation to school, social competence, and academic achievement (Howes, Hamilton & Matheson, 1994; Birch & Ladd, 1997; Howes, 2000; Pianta & Stuhlman, 2004; Beyazkurk & Kesner, 2005; Sahin & Anliak, 2008). Positive and close relationships with the teacher becomes a source of reliability and social support for children, and thus it may set the stage for children to interact with their peers and also benefit from the learning opportunities (Howes, Phillipson, & Peisner-Feinberg, 2000; Hughes & Kwok, 2006; Dotterer & Lowe, 2011; Gregoriadis & Grammatikopoulos, 2014). The children who have a high quality interaction with their teachers during the pre-school period are academically more successful in their further education (Birch & Ladd, 1997; Burchinal, Peisner-Feinberg, Pianta & Howes, 2002), but the children who have negative relationships with their teachers develop negative perceptions about their academic skills (Stipek, Feiler, Daniels & Milburn, 1995; Stipek, 2001; Hughes & Kwok, 2007).

Children consider interactions with their teachers more important than interactions with their peers during the pre-school period (Morrison, 2003). Thus, depending on teachers' state of liking of children, a relationship based on love between the child and the teacher will have a positive effect on

child's development (Rudasill & Rimm-Kaufman, 2009). The first purpose of the research is to determine the pre-school teachers' liking of children levels and the relationship between 60-72 month-old children's feelings about school, opinions about teachers and perceptions about their academic skills. The second purpose of the research is to detect the relationship between 60-72 month-old children's feelings about school, opinions about teachers and perceptions about their academic skills.

## 2. Method

This research was designed using survey model and carried out to determine the pre-school teachers' liking of children levels and the relationship between 60-72 month-old children's feelings about school, opinions about teachers and perceptions about their academic skills and to detect the relationship between 60-72 months-old children's feelings about school, opinions about teachers and perceptions about their academic skills.

**The Study Group:** The population of the study consisted of 60-72 month-old children and their pre-school teachers working in independent pre-schools affiliated with the Ministry of National Education in Aydin. Samplings were not chosen in the research. The teachers who volunteered to participate in the research and six children from these teachers' classes were included in the research. A total of 40 teachers and six children from each teacher's class totally 240 children (120 females-120 males), composed the study group.

40 teachers in the study group are all females. Moreover, all of the teachers have bachelor's degree and work part-time. The information about teachers' age, marital status, having children, the number of children in their classes, professional experience, the reasons for choosing the profession, and the reasons for choosing this profession again was presented in Table 1.

**Table 1. Demographic Information about the Teachers in the Research**

Variables	Groups	f	%	Variables	Groups	f	%
<b>Age</b>	20-30	8	20.0	<b>The reasons for choosing the profession</b>	Liking of children	27	67.5
	31-40	24	60.0		Thinking that the profession is important	5	12.5
	41 and above	8	20.0		Coincidence and necessity	8	20
<b>Marital Status</b>	Single	5	12.5	<b>Choosing the profession again</b>	Yes	34	85.0
	Married	35	87.5		No	6	15.0
<b>The number of children</b>	Yes	32	80.0	<b>Professional experience</b>	0-5 years	4	10.0
	No	8	20.0		6-10 years	17	42.5
<b>The number of children in the class</b>	21 children and above	26	65.0	11-15 years	10	25.0	
	20 children and below	14	35.0	16 years and above	9	22.5	

**Data Collection Tools:** The data were gathered via "General Information Form" and "The Feelings about School Scale (FAS)" and "Barnett Liking of Children Scale (BLOCS)".

**General Information Form:** General information form consists of questions related to the participant teachers' age, gender, education, marital status, having children or not, professional experience, working hours, number of children in the class, reasons for choosing the job, and decision about whether or not choosing the job again.

**Scale for the Feelings about School (FAS):** The original form was developed by Valeski and Stipek (2001) and the FAS measure children's perceptions of academic competence (mathematics and reading and writing), their feelings about the teacher, and their general attitudes toward school. The scale consists of 12 items on a 5-point Likert-type scale. The scale's reliability and validity in Turkey was carried out with the data collected by Ozturk Samur and Inal Kiziltepe (2017) from 318 60-72 month children. The scale's content validity was presented to expert view and in line with the views of the expert, it was decided that the scale turned to a 3-point Likert scale from a 5-point Likert scale. According to the results of the confirmatory factor analysis, the comparative fit indices were determined as  $\chi^2=104.16$ ,  $X^2/sd= 2.03$ ,  $MSEA= 0.058$ ,  $CFI=0.93$ ,  $NNFI=0.91$ ,  $NFI=0.88$  and  $IFI=0.93$ . The scale for the Feelings about School's Cronbach alpha value for school sub-dimension was determined as 0.56, for teacher sub-dimension as 0.44, for reading and writing sub-dimension as 0.29 and for mathematics sub-dimension as 0.35. The scale is administered individually in a quiet and comfortable environment before the scale items are presented, sample questions in the scale are asked so that children can understand the implementation, and after it is made sure that children understand it, the main scale items are asked. After the practitioner addresses the question, s/he wants the child to show the answer on the columns from 1 to 3 with his/her finger.

**Barnett Liking of Children Scale (BLOCS):** Duyan and Gelbal (2008) translated and adapted the scale developed by Barnett and Sinsini (1990) to Turkish and also carried out its reliability and validity study. The scale consists of 14 items, four negative items (3<sup>rd</sup>, 6<sup>th</sup>, 10<sup>th</sup>, and 13<sup>th</sup> items) and 10 positive items and the lowest point to get from the scale is 14 and the highest point is 98. If the points from the scale increases, the level of liking of children increases but if the points decrease, the level of liking of children decreases. The scale is a 7-point Likert type scale which ranges from "Strongly disagree" to "Strongly agree". It was found that the scale's internal consistency was .92 and test-retest reliability coefficient was .85.

**Data Collection and Analysis:** After necessary permission was obtained from Aydin Directorate of National Education, the independent pre-school directors and teachers teaching 60-72 month old children were interviewed and they were informed about the content of the research. General information form and Barnett Liking of Children were administered to 40 teachers who volunteered to participate in the research. Then, they were asked to choose six children, three females and three males, from their classes and the scale of Feelings about School was administered to a total of 240 children, 120 females and 120 males, by the researchers. Frequencies and percentages were calculated for the demographic data about the children and teachers. As a result of the normality test, it was determined that the points 40 teachers got from the BLOCS did not follow a normal distribution. Thus, Spearman Brown's Rank Correlation Coefficient was used to determine the relationship between the scores for sub-dimensions of the scale of Liking of Children and Feelings about School. Because the scores for sub-dimensions of the scale of Feelings about School obtained from 240 children followed a normal distribution, Pearson correlation analysis was used to determine the relationship between the scores for sub-dimensions.

### 3. Findings

Table 2 presents the relationship between the scores for sub-dimensions of the Liking of Children and Feelings about School and Table 3 presents the relationship between the scores for sub-dimensions of Feelings about School.

**Table 2. The relationship between the scores for sub-dimension of the scale of Liking of Children and Feelings about School**

		Teacher	School	Reading and Writing	Mathematics
BLOCS	r	.189	.063	.197	.081
	p	.244	.697	.224	.620
	n	40	40	40	40

As a result of Spearman Brown's Rank Correlation Coefficient, there was not a significant relationship between the sub-dimensions of the Liking of Children and Feelings about School.

**Table 3. The relationship between the scores for sub-dimension of Feelings about School**

Sub-dimensions		Teacher	Mathematic	School
Mathematic	r	<b>.181**</b>		
	p	.005		
	n	240		
School	r	<b>.424**</b>	.121	
	p	.000	.060	
	n	240	240	
Reading and Writing	r	.071	<b>.300**</b>	<b>.227**</b>
	p	.277	.000	.000
	n	240	240	240

\*\* p< 0.01

When Table 3 was examined, it was revealed that there was a statistically significant and positive relationship between the teacher sub-dimension and mathematics and school sub-dimensions and reading and writing sub-dimension and mathematics and school dimension of the scale of Feelings about School (p< 0.01).

#### 4. Discussion and Result

A significant relationship was not found between the sub-dimensions of the scale of Liking of Children and Feelings about School in the research which was carried out to determine the relationships between pre-school teachers' perceptions of liking of children and 60-72 month old children's perceptions of academic competence (mathematics and reading and writing), their feelings about the teacher, and their general attitudes toward school and children's perceptions of academic competence (mathematics, reading and writing), their feelings about the teacher, and their general attitudes toward school. When the relationship between the sub-dimensions of the scale of Feelings about the School was examined, a positive and a significant relationship between the teacher sub-dimension and mathematic and school sub-dimensions and reading and writing sub-dimension and mathematic and school sub-dimensions were revealed.

The quality relationship between a child and a teacher is one of the most important factors that affect child's preparedness of school, orientation, social competence, and academic achievement (Howes, Hamilton & Matheson, 1994; Birch & Ladd, 1997; Howes, 2000; Pianta & Stuhlman, 2004; Beyazkurk & Kesner, 2005; Sahin & Anliak, 2008). The child who feels that s/he is liked by his/her teacher considers him/herself valuable and does not abstain from learning and trying new things (Ercan, 2014). The relationship between the child and the teacher is a very important support particularly for the children at very young ages who try to adapt to the school setting (Birch & Ladd, 1997). Although it looks as if it is stated in literature as stated above, when the findings related to the first purpose of the research was examined, it was found that there was not a significant relationship between the sub-dimensions of the scale of Liking of Children and Feelings about School. It is considered that this result is related to the number of teachers participated in the study.

The results obtained with regard to the second purpose of the research reveal that there is a significant positive relationship between the teacher sub-dimension, mathematics and school sub-dimensions and

reading and writing sub-dimension and mathematics and school sub-dimensions of the scale of Feelings about School. That is, it can be stated the children who have positive perceptions about their teachers have higher perceptions of mathematic competences and they have more positive feelings about school. At the same time, the children with higher perceptions of competences about reading and writing have higher perceptions of mathematic competences and these children have more positive feelings about school. Academic skills which children gain beginning from the pre-school period to the second grade are closely related to their experiences with their parents and teachers. Pianta & La Paro (2003) stated that the positive relationships between the teacher and the child are as important as high-quality curriculum. It is expected that teachers who like children have more positive, encouraging, and supporting behaviors towards children (Kaynak, Ergin, Arslan & Pinarcik, 2015; Bin Dahari & Sabri bin Ya, 2011). Burcinal and et al (2002) claim that the children who have good communication with their teachers, emotionally feel themselves secure and have positive perceptions about school give attention and energy to learning better and thus these children learn much better. It is viewed that the children who like school and are academically successful are more enthusiastic about joining class activities than the children with negative perceptions about school and low academic competences. Moreover, it is considered that the close and warm relationship established with the teacher is more important for very young children who especially need more adult care (Valeski & Stipek, 2001). The teacher plays the role of socializing agent in the school where socialization takes place. Valeski & Stipek (2001) in their study revealed that children's feelings about school and their feelings about teachers and children's perceptions of competence about their academic performances are closely related. Ladd, Birch & Buhs (1999) determined that children who are academically successful like school more and have more positive feelings about their teachers. As seen, there is a mutual relationship between children's perceptions related to feelings about their teachers, academic competence (mathematics and reading and writing) and feelings about school.

In conclusion, the research findings did not reveal a significant relationship between the sub-dimensions of the scales of the Liking of Children and Feelings about School. On the other hand, when the relationship between the sub-dimensions of the scale of Feelings about School was explored, both children's feelings about their teachers and their attitudes towards mathematics and reading and writing correlate with their perceptions about mathematic competences and their attitudes towards school.

### 5. Limitations and Suggestions

40 teachers are included in the research as the study group. In the other studies this number might be increased. Moreover, the scale for Feelings about School was administered to the children selected by the teacher considering only gender factor. Children's academic skills can be considered in the future studies. The children who are assessed with the assessment tool and at different levels of academic skills may be included in the study group and the gender factor can be discussed as a variable.

### References

- Bag, C., & Ceviker, Ay, S. (2017). Okul oncesi ogretmenlerinin ogretmen yeterlikleri ve hizmet ici egitim ihtiyaclari. *Abant Izzet Baysal Universitesi Sosyal Bilimler Enstitusu Dergisi*, 17(1), 289-312.
- Barnett, M. A., & Sinisi, C. S. (1990). The initial validation of a liking of children scale. *Journal of Personality Assessment*, 55(1-2), 161-167.
- Beyazkurk, D., & Kesner, J. E. (2005). Teacher-child relationships in Turkish and United States Schools: A cross-cultural study. *International Education Journal*, 6(5), 547-554.
- Bin Dahari, Z., & Sabri bin Ya, M. (2011). Factors that influence parents' choice of preschool education in Malaysia: an exploratory study. *International journal of Business and Social Science*, 2(15), 115-128.
- Birch, S. H., & Ladd, G. W. (1997). The teacher-child relationship and children's early school adjustment. *Journal of School Psychology*, 35(1), 61-79.



- Brown, N., Morehead, P., & Smith, J. B. (2008). But I love children: Changing elementary teacher candidates' conceptions of the qualities of effective teachers. *Teacher Education Quarterly*, 35(1), 169-183.
- Burchinal, M. R., Peisner-Feinberg, E., Pianta, R., & Howes, C. (2002). Development of academic skills from preschool through second grade: Family and classroom predictors of developmental trajectories. *Journal of School Psychology*, 40(5), 415-436.
- Dotterer, A. M., & Lowe, K. (2011). Classroom context, school engagement, and academic achievement in early adolescence. *Journal of Youth and Adolescence*, 40(12), 1649-1660. doi: 10.1007/s10964-011-9647-5
- Downing, J. E., Ryndak, D. L., & Clark, D. (2000). Paraeducators in inclusive classrooms: Their own perceptions. *Remedial and Special Education*, 21(3), 171-181.
- Durmusoglu Saltali, N., & Erbay, F. (2013). Okul oncesi ogretmenlerinin konusma, dinleme ve empati becerilerinin cocuk sevmeye davranisi acisindan incelenmesi. *Ahi Evran Universitesi Kirsehir Egitim Fakultesi Dergisi (KEFAD)*, 14(1), 159-174.
- Duyan, V., & Gelbal, S. (2008). Barnett cocuk sevmeye olcegini Turkece 'ye uyarlama calismasi. *Egitim ve Bilim*, 33(148), 40-48.
- Ercan, R. (2014). Ogretmenlerde cocuk sevgisi. *Turkish Studies*, 9(8), 435-444.
- Erdogan, G., & Cuceloglu, D. (2013). *Ogretmen olmak: Bir Can'a dokunmak*. Istanbul: Final Kultur Sanat Yayinlari.
- Ergun, M. & Ozdas A. (1999). Okul gozlemi ve uygulama calismalarinin ogretmen adaylari uzerindeki etkisi. *AKU Sosyal Bilimler Dergisi*, 3, 115-119.
- Gelbal, S., & Duyan, V. (2010). Ilkogretim ogretmenlerinin cocuk sevmeye durumlarina etki eden degiskenlerin incelenmesi. *Hacettepe Universitesi Egitim Fakultesi Dergisi*, 38, 127-137.
- Gregoriadis, A., & Grammatikopoulos, V. (2014). Teacher-child relationship quality in early childhood education: The importance of relationship patterns. *Early Child Development and Care*, 184(3), 386-402. doi:10.1080/03004430.2013.790383.
- Howes, C., Hamilton, C., & Matheson, C. (1994). Children's relationships with peers: Differential associations with aspects of the teacher-child relationship. *Child Development*, 65, 253-263.
- Howes, C. (2000). Socio-emotional classroom climate in childcare, child-teacher relationships and children's second grade peer relations. *Social Development*, 9(2), 191-204.
- Howes, C., Phillipsen, L., & Peisner-Feinberg, E. (2000). The consistency and predictability of teacher-child relationships during the transition to kindergarten. *Journal of School Psychology*, 38(2), 113-132.
- Hughes J. N., & Kwok, O. (2006). Classroom engagement mediates the effect of teacher-student support on elementary students' peer acceptance: A prospective analysis. *Journal of School Psychology*, 43(6), 465-480.
- Hughes, J. N., & Kwok, O. (2007). Influence of student-teacher and parent-teacher relationships on lower achieving readers' engagement and achievement in the primary grades. *Journal of Educational Psychology*, 99(1), 39-51. doi:10.1037/0022-0663.99.1.39
- Kaynak, K. B., Ergin, B., Arslan, E., & Pinarcik, O. (2015). Okul oncesi ogretmeni adaylarinin benlik saygilari ile cocuk sevmeleri arasindaki iliskinin incelenmesi. *Ilkogretim Online*, 14(1), 86-96. doi: 10.17051/io.2015.35947
- Kok, M., Ciftci, M., & Ayik, A. (2011). Ogretmenlik meslegi ozel alan yeterliklerine iliskin bir inceleme. *Ataturk Universitesi Sosyal Bilimler Enstitusu Dergisi*, 15(1), 169-183.
- Ladd, G., Birch, S., & Buhs, E. (1999). Children's social and scholastic lives in kindergarten: Related spheres of influence? *Child Development*, 70, 1373-1400.
- Lasley, T. (1980). Preservice teacher beliefs about teaching. *Journal of Teacher Education*, 31(4), 38-41.
- Marso, R. N., & Pigge, F. L. (1994). *Personal and family characteristics associated with reasons given by teacher candidates for becoming teachers in the 1990's: Implications for the recruitment of teachers*. Paper presented at the Annual Conference of the Midwestern Educational Research Association Chicago, IL. [Available online at: <https://files.eric.ed.gov/fulltext/ED379228.pdf>] Retrieved on December 20, 2017.

- Mete, Y. A. (2013). Guney Kore, Japonya, Yeni Zelanda ve Finlandiya'da ogretmen yetistirme ve atama politikolari. *Turkish Studies*, 8(12), 859-878.
- Morrison, G. S. (2003). *Fundamentals of early childhood education*. New Jersey: Pearson Education Inc.
- O'Connor, E., & McCartney, K. (2006). Testing associations between mother-child and teacher-child relationships. *Journal of Educational Psychology*, 26(5), 301-326. doi: 10.1037/0022-0663.98.1.87.
- Ozturk Samur, A., & Inal Kiziltepe, G. (2017). Okulum ve ogretmenim hakkında ne dusunuyorum? *Hitit Universitesi Sosyal Bilimler Enstitusu Dergisi*, 10(2), 1257-1276. doi:10.17218/hititsosbil.321933.
- Pianta, R.C., & La Paro, K. (2003). Improving early school success. *Educational Leadership*, 60(7), 24-29.
- Pianta, R. C., & Stuhlman, M. W. (2004). Teacher-child relationships and children's success in the first years of school. *School Psychology Review*, 33(3), 444-458.
- Rudasill, K. M., & Rimm-Kaufman, S. E. (2009). Teacher-child relationship quality: The roles of child temperament and teacher-child interactions. *Early Childhood Research Quarterly*, 24(2), 107-120. doi:10.1016/j.ecresq.2008.12.003.
- Saracho, O. N., & Spodek, B. (2007). Early childhood teachers' preparation and the quality of program outcomes. *Early Child Development and Care*, 177(1), 71-91. doi: 10.1080/03004430500317366.
- Stipek, D., Feiler, R., Daniels, D., & Milburn, S. (1995). Effects of different instructional approaches on young children's achievement and motivation. *Child Development*, 66(1), 209-223.
- Stipek, D. (2001). Path ways to constructive behavior: Importance of academic achievement in the early elementary grades. In A. Bohart & D. Stipek (Eds.), *Constructive and destructive behavior: Implications for family, school and society*. Washington, D.C.: American Psychological Association
- Sahin, D., & Anliak, S. (2008). Okul oncesi cocuklarinin ogretmenleriyle kurduklari iliskiyi algilama bicimleri. *Egitim Bilimleri ve Uygulama*, 7(14):215-230
- Valeski, T., & Stipek, D. (2001). Young children's feelings about school. *Child Development*, 72(4), 1198-1213.
- Veenman, S. (1984). Perceived problems of beginning teachers. *Review of Educational Research*, 54(2), 143-178.
- Yoleri, S. (2014). *Okul oncesi ogretmenlerinin cocuk sevme duzeyine etki eden degiskenlerin incelenmesi* [Oz]. Uluslararası EJER 2014 Konferansında sunulan bildiri, Istanbul Universitesi, Istanbul. Erisim adresi: <http://ejercongress.org/2014/>



# The Thesis Journey: “Doctoral Candidate’s Perspectives”

Gulsah Tasci, H. Tezer Asan

## 1. Introduction

PhD thesis is a very important journey in higher education, and also in this journey, the support provided to the doctor students are to influence the future academic life is invaluable. The thesis process has an unforgettable and special phase for everyone (Määttä, 2011). Particularly, writing a doctoral thesis requires a tremendous effort, determination, ability and ambition (Määttä, 2011, Lindsay, 2015, Odena & Burgess, 2017) According to Määttä (2011), "Doctoral thesis must meet official academic standards. However, these standards explain how a doctoral student's personal daily life will change over the course of this thesis and how the doctoral student demands effort, support and empathy from other doctoral student and close friends." Therefore, overcoming thesis stage in the most productive and healthy way is an important step for the actualization of hopes of the people set their hearts on science.

When general philosophy and context of the doctoral program in Turkey is examined, it would be easier to understand the frame of the education. According to Postgraduate Education and Training Regulations of Turkey; (2016) "Doctoral program offers students the abilities to research independently, to interpret data and scientific problems with deep and broad perspective and to analyze." Also, according to the 15th article of the Postgraduate Education and Training Regulation, "The Ph.D. program gives the students the skills to do independent research, analyze scientific problems, interpret the data with a broad and deep perspective, analyze, analyze and reach new syntheses. The doctoral program requires a minimum of 240 ECTS credits including at least seven courses, seminars, proficiency exams, thesis proposals and dissertations and it should not be less than twenty one credits and 60 ECTS credits for graduate students with master degree."

This process, which has started with the appointment of a counselor, is significantly influenced by the nature of product and the efficiency of the counselor and student relationship (Styles & Radloff, 2001). Sezgin (2002) likens that the relationship between the thesis counselor and thesis student in the thesis writing process to a kind of mentoring relationship and emphasizes that experienced and knowledgeable faculty members will play an important role both formally and informally. On the other hand, the researches which focus on difficulties faced during dissertation stage indicate that students have several troubles (Bakioglu & Gurdal, 2001; Green & Kluever, 1997; Gordon, 2003; Inman & Silverstein, 2003; Strachan, vd., 2004; Suna etc, 2007; Miller, 2009).

Besides, Ho et al. (2010) identified 17 possible factors that a doctoral student experience difficulty while studying: Thesis research, lack of understanding in writing thesis, data collection difficulty, tense and disturbing environment, excessive time and constraints, external pressures, interpersonal conflicts, personal qualities of students, personal qualities of counselor, lack of external sources, lack of support from peers, family and counselor, financial needs, length of thesis process, lack of departmental pressure, negative effects of peers and lack of plan " (p.123).

In this point, it is undisputable that, doctoral candidates are facing several troubles during the dissertation stage in Turkey as well as the world. Despite the existence of such difficulties, there are limited studies to research the extent of this phenomenon. It is seen that, most of the researches focus on academic troubles. The difficulties faced by the students affect their lives both academically, psychologically and sociologically. For this reason, the purpose of the research is to examine the problems faced by doctoral students in the thesis process. For this purpose, the following questions were asked:

What are the difficulties faced by the doctoral students in the writing process of thesis?

## 2. Factors Affecting the Dissertation Process

It is seen that students are facing academic, psychological, economic and social environment-based difficulties when it is approached with general perspective toward difficulties faced during dissertation stage.

First of all, these difficulties are **academic difficulties**. Especially student-counselor relation is one of them. Thesis counseling and guidance is a developing process that involves the sharing ideas in a very close relationship with the student (Murphy et al., 2007). The research also suggests that the presence of a participatory and supportive counselor contributes to the successful completion of the research (Maher et al., 2004). At the same time researches on the subject show that students perceive establishing good relationships with their counselors as a fundamental requirement (Appel & Dahlgren, 2003; Curtin, Stewart, & Ostrove, 2013). There is a great deal of research stating that consultants occasionally negatively affect the work of students (Ho et al., 2010; Wright, 2010; Mohamed et al., 2012; Khozaei et al, 2015).

Another academic trouble is that doctoral students feel themselves insufficient academically during the dissertation stage and also they lack of research ability and have structural deficiency (De Valero, 2001). Also, it is important to establish a good student-counselor relationship by mutual understanding of each other's expectations. The counselors' guiding in this process can reduce the students' anxieties. When the previous studies are reviewed, there are many studies referring to the importance of the counselor in the thesis process. At the same time, there is a lot of research referring to the importance of consultant and student relationship in a successful thesis process. The research process can be shown as the other important component of the thesis writing process in doctoral studies.

One of the important points is the feedback given to the doctoral student on his/her work in the thesis writing process. Inadequate feedback can cause problems in the progress of the thesis. Therefore, it is important that both the counselor and the thesis monitoring committee are clear. According to Feldon et al. (2015) "Inadequate counseling has noted that participants negatively influence their perceptions of their abilities and the opportunity to receive targeted feedback."

Students are facing many difficulties including not being able to identify the subject, not studying on the desired subject, not having sufficient library and other resources, and not receiving timely and sufficient feedback from the counselor during the dissertation stage (Bakioglu & Gurdal, 2001; Suna et al., 2007).

Besides, students, are also having troubles such as not being able to start writing a thesis, not planning the study period, failing to clear expectations, being unsure about the dissertation stage, not getting enough time, and not being able to work under a timetable (Strachan, et. al, 2004).

Another difficulty is **social environment based difficulties**. In this period, doctoral student sometimes can't balance his/her social and academic life and is having some troubles. For instance; some factors in the life of a person such as being married with children or working in a full-time job outside of university may lead to late graduation or failure of post-graduate education (Baird, 1997). During the doctoral dissertation stage, doctoral students are facing some problems in social environments such as family and friends. Spouse or children obstacles, loneliness or feelings of isolation that result from not having enough time for friends are other difficulties faced.

Another trouble faced is **psychological difficulty**. While the students in the dissertation stage are experiencing troubles such as fear, anxiety and not to being sure of themselves (Gordon, 2003), the attitudes related with the extreme perfectionism are also one of the factors that keep students away from, so, anxiety affects dissertation stage. (Foss & Waters, 2007 cited Locke a & Boyle, 2016) Time management is another difficulty faced by students.

Finally, **economic difficulties**; doctoral students are having some troubles about bringing sources from abroad, starting paying school fee because of extending process and etc. during the dissertation stage (Ho et al, 2010).

### 3. Method

In this study, qualitative research methods have been used in this study. Phenomenological method has been used as a qualitative research method. Creswell (2007) suggests in-depth interviews with participants as a method of data collection in phenomenological studies. Based on the relevant conceptual framework, a semi-structured interview form was created to collect data by the researchers. Interview questions consist of two parts. In the first part, demographic information about participants and dissertation was asked while in the second part difficulties faced during dissertation stage were asked. Interviews were conducted using face-to-face interview method.

Participants of this research consist of 10 volunteer graduates who finished their doctorate studies at various universities in Istanbul. All participants are graduated now. Interviews were performed with 7 women and 3 men. At the request of the participants their names are kept confidential and are called as P1-P10. The population is composed of doctoral students graduated from universities in Istanbul. The sample of the research was created by using the purposeful sampling method. Purposeful sampling means, making the most suitable part of the population as observation subject. (Sencer, 1989, p.386). The time passed for participants to start thesis actively and to finish it varies between 24 to 48 months. In this direction, institute of social sciences and institute of science graduate, doctoral students were selected. Ages of the participants depends on between 26 and 34.

The findings were used as a conceptual framework for writing the thesis proposed by Määttä (2011) in 5 stages. Thematic analysis was done according to this conceptual framework. In order to increase internal validity, data was supported with direct quotation. (Lecompte and Goetz, 1982).

**Table 1.** The Overview of the participants' demographic and academic characteristics

Participant	Sex	Age	Department	Country
P1	Female	27	Science	Turkey
P2	Female	30	Social	Turkey
P3	Female	26	Social	Turkey
P4	Female	28	Social	Turkey
P5	Male	26	Social	Turkey
P6	Female	29	Sciences	Turkey
P7	Female	32	Sciences	Turkey
P8	Female	34	Social	Turkey
P9	Male	28	Social	Turkey
P10	Male	29	Science	Turkey

### 4. Findings

The findings obtained in the study were examined under the following headings Määttä (2011):

- (1) *"Getting Started"*,
- (2) *"Being Hooked on the Dissertation Process"*,
- (3) *"Putting One's Social Life to the Test"*,
- (4) *"The Strain of One's Own Demands and Expectations"* and
- (5) *"Will Everything Be All Right if the End Is All Right?"*

#### 4.1. Getting Started

At this stage, participants expressed their fear and concern about the thesis writing process. They expressed that they found it hard to start writing the thesis and that they waited for a long time. One of the participants' views is as follows:

*When I chose the thesis subject and started to research, I was in fear and trembling. Firstly, there were a few conducted studies in that field. In my case, the example was very scarce especially in my thesis subject; I got confused in the process. I even thought if I should change the subject? (K2).*

#### **4.2. Being Hooked on the Dissertation Process**

Interviewed participants explained how they were detached from life, particularly in the process of writing theses. They mentioned that they did not even realize creating an autonomous living space especially in this process; they were amazed at how they managed to survive in this process after the thesis was over. One of the participants' views is as follows:

*I was like in another world during the thesis writing process. I've been thinking about it all the time. How will the result come out? How do I analyze it? I was thinking about those (K1).*

*I could not go on a vacation because I would not feel at ease. I could not sleep much because I felt guilty. My desire to do the best has covered almost my whole life (K3).*

#### **4.3. Putting One's Social Life to the Test**

In this phase, the participants expressed that they had difficulties in their social relationships, like relationships with family and friends.

*My own living space was getting narrower in the thesis writing process. I was studying all the time. I did not even have time for my family or even myself. Occasionally, my friends started asking me when this thesis would end.. (K5).*

*In the process of writing theses, my wife was so patient with me ... that she was cooking. She took care of our child. The fact she understood me in this process helped me to stay strong. (K3)*

*From time to time I experienced troubles with my counselor. I was constantly tense ... he was very busy. That made me sad. The fact that I could not get enough support and he did not spare me time made our relationship worse in the process (K4).*

*I was trying to relax by having academic conversations with my friends, especially with my doctoral friends. We could understand each other. (K10)*

#### **4.4. The Strain of One's Own Demands and Expectations**

Participants expressed that they found themselves in a deadlock or made mistakes about their work due to social pressures and the desire to finish the thesis as soon as possible due to inner pressures.

On the other hand, the participants expressed the difficulty in producing something about the thesis at this stage, and that the production observed in the first stages left its place to a certain sense of uncertainty and stress in this phase. And they stated that they had problems with getting feedback especially from their counselors at this stage. Besides, inadequate guidance, ineffective reading and insufficient suggestions of the counselors are among the other problems they are experiencing.

Another problem is that the participants expressed exhaustion since the thesis process take too many years due to the counselor's demand of thesis corrections, continuing researching, adding new sections etc. Another problem experienced between the counselor and the doctoral student is the counselor's use of language in their feedback. Some participants expressed their discomfort due to tough use of language used in the feedbacks.

*My counselors' humiliating attitudes such as how can you do a mistake like this, caused to lower my motivation for months. (K8)*

*My counselor demanded new things in every meeting. The draft we created at the beginning was completely changed. I felt exhausted. The same ongoing issue has worn me out for years. (K6)*

*My friends, my family, etc. always asked me when your thesis will end. When would my thesis really end? (K9)*

*My counselor did not have time to discuss the details of thesis. He did not spare enough time for me. I had to work out the thesis alone. I was going ahead on this road alone and I was wondering about the result (K8)*

#### 4.5. Will Everything Be All Right if the End Is All Right?

At this stage, the participants stated that they had overcome these difficulties. They even say that the difficulties they encounter fed their thesis and that they are proud to be able to produce such a good product.

*It was finally over. I could not believe ... I am proud to overcome those difficulties (K5).*

### 5. Discussion

In this article, the difficulties experienced by doctoral students during the thesis life has been tried to be identified. The discussion of the results found in the study in comparison to the findings of previous studies can be summarized under four headings. As a result of this study, the findings reveal the various difficulties that doctoral students encountered in the thesis writing process.

**Academic difficulties:** The first factor emerging from the views of the participants is that they have academic challenges difficulties are among the difficulties faced by doctoral students. These difficulties include the lack of academic competence (Robinson and Kuin, 1999; De Valero, 2001), the communication problems between counselors and students (Styles & Radloff, 2001; Mohamed et al, 2012), the personality traits of the doctoral student (being comfortable or being worried) (Ho et al, 2010) the personality traits of the counselor (Ho et al, 2010), time management (Strachan et al, 2004; Ho et al, 2010), inadequate feedback of thesis tracking committees ( Ipek-Akbulut et al., 2013) and inadequate feedback (Bakioglu & Gurdal, 2001; Suna vd., 2007; Feldon et al. 2015).

**Psychological difficulties:** The second factor emerging from the views of the participants is that they have psychological challenges psychological difficulties are among the difficulties faced by doctoral students. This finding is similar to the study of Ho et al (2010) psychological difficulties.

**Social difficulties (family, friends etc.):** The third factor emerging from the views of the participants is that they have effect of social circle challenges social difficulties are among the difficulties faced by doctoral students. This finding is similar to the study of Ho et al (2010) social difficulties.

**Economic difficulties:** The fourth factor emerging from the views of the participants is that they have economic challenges financial difficulties are among the difficulties faced by doctoral students. This finding is similar to the study of Ho et al (2010).

### 6. Recommendations

In this study, the difficulties experienced by doctoral students during the thesis life has been tried to be identified. The following suggestions can be made in the light of findings: thesis writing support centers can be created within Turkish universities in thesis writing process. The number of lessons can be reduced to decrease the intensity of consultants. Thesis tracking committees can be made more functional and thereby provide more feedback. Various organizations can be organized for social and emotional support. The problems can be discussed periodically with the same peers by creating thesis writing groups. Seminars can be given to students and counselors on how the student-counselor relationship should be in the thesis process with regard to counselors' use of language in motivating the students.

Finally, writing a thesis in Turkey traditionally became a process that takes many years and that leads to a sense of exhaustion in the student. Making the necessary arrangements will lead to more efficient results.

### 7. References

- Appel, M., & Dahlgren, L. (2003). Swedish Doctoral Students Experiences On Their Journey Towards A Phd: Obstacles And Opportunities Inside And Outside The Academic Building. *Scandinavian Journal of Educational Research*, 47(1): 89–110.
- Baird, L. L. (1997). Completing the dissertation: Theory, research, and practice. *New Directions for Higher Education*, 1997(99): 99-105.



- Bakioglu, A. & Gurdal, A. (2001). Lisansustu Tezlerde Danisman ve Ogrencilerin Rol Algilari: Yonetim Icin Gostergeler [Role of Counselors and Students in Graduate Theses Perceptions: Indicators for Management], Hacettepe Universitesi Egitim Fakultesi Dergisi [Hacettepe University Journal of Education ], 21:9-18.
- Creswell, J. W. (2007). *Qualitative inquiry & research design: Choosing among five approaches* (2nd ed.). Thousand Oaks, California: Sage Publications.
- Curtin, N., Stewart, A. J., & Ostrove, J. M. (2013). Fostering academic self-concept: Advisor support and sense of belonging among international and domestic graduate students. *American Educational Research Journal*, 50(1): 108-137.
- De Valero, Y. F. (2001). Departmental factors affecting time-to-degree and completion rates of doctoral students at one land-grant institution. *Journal of Higher Education*, 72(3): 341-367.
- Feldon, D. F., Mahr, M. A., Hurst, M., & Timmerman, B. (2015). Faculty mentors', graduate students', and performance-based assessments of students' research skill development. *American Educational Research Journal*, 52(2):334-370
- Gordon, P. J. (2003). Advising to avoid or to cope with dissertation hang-ups. *Academy of Management Learning and Education*, 2(2): 181-187.
- Green, K. E. & Kluever, R. C. (1997). *The dissertation barriers scale*. Chicago, IL: Paper presented at the Annual Meeting of the American Educational Research Association.
- Ho, J.C.W., Wong, L.C.J. & Wong, P.T.P. (2010). What helps and what hinders thesis completion: a critical incident study. *International Journal of Existential Psychology and Psychotherapy*, 3(2): 117-131.
- Ipek-Akbulut, H., Sahin, C. and Cepni, S. (2013). Determination of Faced Problems in Doctorate Thesis Process: Education Faculty Sample. *Dicle University Faculty of Education Ziya Gokalp Journal* ,20: 50-69.
- Inman, A. G. ve Silverstein, M. E. (2003). Dissertation support group: To dissertate or not is the question. *Journal of College Student Psychotherapy*, 17(3): 59-69.
- Kearns, H., Gardinera, M. & Marshalla, K. (2008). Innovation in PhD completion: the hardy shall succeed (and be happy!), *Higher Education Research & Development*, 27(1):77-89.
- Khozaei, F., Naidu, S., Khozaei, Z., & Salleh, N.I. (2015). An exploratory study of factors that affect the research progress of international PhD students from the Middle East, *Education + Training* ,57(4):448-460
- Krauss, S. E., & Ismail, I. A. (2010). PhD students' experiences of thesis supervision in Malaysia: Managing relationships in the midst of institutional change. *The Qualitative Report*, 15(4), 802-822. Retrieved from <http://www.nova.edu/ssss/OR/OR15-4/krauss.pdf>
- LeCompte, M. D. ve Goetz, J. P. (1982). Problems of reliability and validity in ethnographic research. *Review of Educational Research*, 52:31-60.
- Lindsay, L. (2015) What works for doctoral students in completing their thesis? *Teaching in Higher Education*, 20 (2):183-196.
- Locke, L. A., & Boyle, M. (2016). Avoiding the A.B.D. abyss: A grounded theory study of a dissertation-focused course for doctoral students in an educational leadership program. *The Qualitative Report*, 21(9), 1574-1593.
- Maher, M. A., Ford, M. E., & Thompson, C. M. (2004). Degree progress of women doctoral students: Factors that constrain, facilitate, and differentiate. *The Review of Higher Education*, 27(3), 385-408.
- Manathunga, C. (2005). Early warning signs in postgraduate research education: a different approach to ensuring timely completions. *Teaching in Higher Education*, 10(2):219-233.
- Määttä, K. (2011). The Dissertation Process Described By Doctoral Students In Finland, *e-International Journal of Educational Research*, 2(1): 66-80.
- Mohamed, A., Ismail, A.H., Mustaffa, M.M. & Mohd, N. (2012). Exploring factors influencing the success of doctoral students in engineering, *Procedia – Social and Behavioural Sciences*, 60:325-332.
- Miller, A. B. (2009). *Finish your dissertation once and for all! How to overcome*

- psychological barriers, get results, and move on with your life*. Washington, DC: American Psychological Association.
- Murphy, N., Bain, J. D., & Conrad, L. M. (2007). Orientations to research higher degree supervision. *Higher Education*, 53(2), 209–234
- Odena, O. & Burgess, H. (2017) How doctoral students and graduates describe facilitating experiences and strategies for their thesis writing learning process: a qualitative approach. *Studies in Higher Education*, 42 (3): 572-590.
- Postgraduate Education and Training Regulations of Turkey (2016). [20 Nisan Resmî Gazete Sayı : 29690 Lisansustu Egitim ve Ogretim Yonnetmeliği]
- Sezgin, F. (2002). Arastirma gorevlilerinin yetistirilmesinde tez danismani ogretim uyelerinin yetistiricilik rolleri. [The role of the thesis advisor teaching members in the training of research staff] Yuksek Lisans Tezi, Gazi Universitesi Egitim Bilimleri Enstitusu: Ankara [ Graduate Thesis, Gazi University Institute of Educational Sciences: Ankara].
- Sencer, M. (1989). Toplum bilimlerinde yontem. [Method in social sciences]. Istanbul: Beta.
- Suna, C., Karadag, R. & Selanik Ay, T. (2007). Yuksek lisans programi ogrencilerinin bilimsel arastirma surecinde karsilasilan sorunlara iliskin gorusleri. [The opinions of graduate students on the problems encountered in the scientific research process] Egitim Bilimleri Enstitusu III. Lisansustu Egitim Sempozyumu Bildiriler Kitabı [Institute of Educational Sciences III. Postgraduate Education Symposium Book], Eskisehir.
- Strachan, R., Murray, R. ve Grierson, H. (2004). A web-based tool for dissertation writing. *British Journal of Educational Technology*, 35(3), 369-375.
- Styles, I., & Radloff, A. (2001). The Synergistic Thesis: Student and Supervisor Perspectives. *Journal of Further and Higher Education*, 25(1), 97–106.
- Wright, T. (2003). Postgraduate research students: people in context? *British Journal of Guidance & Counselling*, 31(2), 209–227.



# The Views of Foreign Language School Lecturers on Technological Leadership

Osman Ferda Beytekin, Melih Unal

## 1. Introduction

Technology is the application of knowledge, tools and skills to solve problems and expand human capabilities (Smith, 1994). Technology offers new features that lead to significant changes in the organization. In discussions of the potential role of technology in education, Fiske and Hammond (1997) stated that instructional technology is the key to the quality of education in the new millennium. Many educators believe that the implementation of educational computing can improve teaching and learning (Bauer & Kenton, 2005; Flanagan & Jacobsen, 2003). The use of technology in the teaching-learning process improves students' writing skills, enhances cooperative learning and curricular integration, strengthens cross-national teaching practices and teacher communication, and reinforces community relationships and global students (Whitehead, Jensen & Boschee, 2003).

Various factors, such as the rapid development of technology, the global appearance of education and changes in educational policies increase educational sanctions and expectations from school. Strict competition between schools, the emergence of new educational approaches and the complexity of roles expected of school administrators and educators result from the changes. As the expectation of creating more effective and productive learning communities in schools increases, it is now more important for school administrators and instructors to be aware of their leadership roles in technology use and implementation (Afshari, Bakar, Luan, Samah & Fooki, 2009; Akbaba-Altun & Gurer, 2008; Dexter, 2005). With the integration of technology in all areas of education, school administrators and educators have been forced to have certain competencies. School administrators and educators are expected to be competent in using technology and to lead the way in using technology in management, teaching and learning applications.

Tanzer (2004) defines the technology leader as "the person who manages and influences the necessary coordination for effective and efficient use of technology in the organization". At the same time, this definition underscores the way administrators and educators must follow to use technology in the most productive way. It is therefore important that school administrators and educators define and standardize technology leadership roles. Even though standardization in educational management is a very difficult process (Turan & Sisman, 2000), school administrators should have the necessary competences in terms of technology leadership.

Based on research studies, a variety of factors have been found to influence technology integration in schools (Mumtaz, 2000; Williams, Coles, Wilson, Richardson, 2000). Among them, the leadership role of administrators and educators is the most important factor influencing the successful integration of technology (Byrom & Bingham, 2001; Arslan, 2018). School administrators and educators have a great responsibility to initiate and implement changes at school using information and communication technologies (ICTs).

Leadership is a key component in guiding today's learners to the teaching-learning process needed to prepare themselves for the knowledge and skills of today's society to become a productive citizen of the twenty-first century (Byrom & Bingham, 2001). Indeed, leadership is an important factor in the development of effective, innovative schools and facilitation of quality teaching and learning (Dinham, 2005). Today's school administrators and educators should focus not only on the day-to-day activities of a school, but also on student learning, standards, and decision making based on data and restructuring efforts (Felton, 2006).

In our age, education leadership faces strategic decisions to combat competition and to be useful to students. In the current wave of the present, internet and affordable information technologies create a globalized environment for education leaders to face competition from outside their own regions. In other words, schools have evolved from relatively closed systems where a leader is responsible for

producing pre-determined results, to dynamic systems that must adopt and respond to rapid social changes at global level. This kind of technological leadership is a fundamental process management procedure required to guide today's educators and students in the 21st century (Beytekin, 2014; Arslan and Rata, 2013).

Many countries have set standards, performance indicators, or competencies for educators and administrators to use technology vigorously in education. From these countries, the United States began using the National Educational Technology Standards (NETS), the project of the International Society for Technology in Education (ISTE), in the education system. Australia, UK, China, Ireland and some Latin American countries have adopted ISTE's NETS standards. ISTE has updated the NETS at various times, making it suitable for more than one field (Gurol, Yavuzalp, Bagcaci, Serhatlioglu, 2009). There are 5 NETS approaches in total; for students (NETS-S), for educators (NETS-E), for administrators (NETS-A), for computer science educators (NETS-CSE) and for coaches (NETS-C). NETS-E, the main theme of this work, was released in 2017 and has 24 performance indicators under 7 main headings. These extended NETS-E standards are an updated version of the NETS-T (Teacher) standards published in 2008, which includes a total of 20 performance indicators under 5 main headings.

The NETS-E standards are intended as a road map to help students become empowered learners. These standards are designed to deepen the practices in schools, encourage collaboration among colleagues, and reassess traditional approaches and prepare students to encourage their own learning.

## **Iste Standards For Educators**

### **Empowered Professional**

#### 1. Learner

Educators continually improve their practice by learning from and with others and exploring proven and promising practices that leverage technology to improve student learning.

#### 2. Leader

Educators seek out opportunities for leadership to support student empowerment and success and to improve teaching and learning.

#### 3. Citizen

Educators inspire students to positively contribute to and responsibly participate in the digital world.

### **Learning Catalyst**

#### 4. Collaborator

Educators dedicate time to collaborate with both colleagues and students to improve practice, discover and share resources and ideas, and solve problems.

#### 5. Designer

Educators design authentic, learner-driven activities and environments that recognize and accommodate learner variability.

#### 6. Facilitator

Educators facilitate learning with technology to support student achievement of the 2016 ISTE Standards for Students.

#### 7. Analyst

Educators understand and use data to drive their instruction and support students in achieving their learning goals (ISTE, 2017).

According to Turan and Sisman (2000), the most important issue that has recently been needed in Turkey is the study of standards in educational management. This is because the laws and regulations in Turkey only focus on some of the duties of school principals. So, school management becomes just about a routine.

Schools of Foreign Languages (SoFL) which provide English language instruction to all programs in higher education institutions, have critical responsibilities. This language education is performed by lecturers. Previous studies have shown that English learners have positive beliefs and attitudes about the use of information technology in lessons as they have significantly improved their listening and

reading skills. Other findings reveal that English language instructors who use the technology more effectively in their lessons can be more useful to their students and that educators need professional development practices (Nomass, 2013; Alkan & Durmus, 2013). For this reason, the views and attitudes of the lecturers of the SoFL regarding the standards of technology leadership have been evaluated.

Researchers in Turkey and around the world have generally studied the technological leadership of the school administrators or teachers or their views on the subject. Since the education institutions include both administrators and educators, researches on increasing the awareness of the educators about the technological leadership and standards should be carried out in addition to the studies on managerial standards and improvement.

The studies in the literature mostly include the opinions of the administrators and educators at primary or secondary school level. We have not been able to find any relevant information about the university and the School of Foreign Languages. This study is authentic because no research has been done in the same context in the literature and could provide guidance to future standards that will be identified for Turkey.

The purpose of this study is to examine the views of lecturers at Schools of Foreign Languages on the National Educational Technology Standards (NETS-E) developed for educators by the International Society for Technology in Education (ISTE), and to evaluate the compliance of these standards in Turkey from their perspective.

## 2. Method

The study was conducted by qualitative research method. The participant group of the study consists of 25 randomly selected lecturers who work at the Schools of Foreign Languages in state and private universities. The data collection phase of the survey took place between May-June 2018 and was based on individual face-to-face interviews. The aim here is to ensure that the participants in the sample reflect their views deeply and sincerely.

**Table 1. Characteristics of Study Participants (n = 25)**

<b>Characteristics</b>	<b>n</b>	<b>Characteristics</b>	<b>n</b>
<b>Type of Academic Institution</b>		<b>Education</b>	
State University	15	Bachelor's Degree	14
Foundation University	10	Master's Degree	8
<b>Age</b>		Doctorate	3
30 and under	7	<b>Gender</b>	
31-40	7	Female	15
41-50	6	Male	10
51 and over	5	<b>Total</b>	25

As seen in Table 1, 15 of the instructors (n = 25) who participated in the interviews work at state universities, 10 at private universities. Fifteen of them are female and 10 of them are male. Out of 25 participants, 14 completed bachelor's degrees, 8 master's degrees and 3 doctoral degrees. Seven of the participants included in the study are 30 years old and under, seven are between 31-40, six are between 41-50, and five of them are 51 and over.

The interview form consists of two parts. The first part of the interview form was designed to determine the demographic information of the educators involved in the study. The second part of the interview form included open-ended questions covering 7 main headings of the National Educational Technology Standards for Educators (NETS-E).

The researcher has been very careful to maintain his impartiality while promoting conversation by going through the reflective listening technique during one-on-one interviews. At the same time, an

environment was created in which participants could express their views and suggestions without any influence. After each interview, the "Interview Contact Summary Form", which was prepared with reference to Miles and Huberman (1994), was used for interview details and content. The interviews were held in the offices of the participating educators, usually taking about 30 minutes.

Within the scope of the research, the e-mails prepared for the invitees who would participate in one-on-one interviews included the National Educational Technology Standards for Educators and Students (NETS-E & NETS-S). Participants were interviewed on face-to-face meetings between May-June 2018 after the feedbacks indicating that they voluntarily participated in the work.

Within the scope of providing the internal validity of the research, participants were contacted by electronic mail, telephone or face-to-face interaction after the face-to-face interviews. The interview texts were examined in depth and the concepts within the texts and between the texts were compared and interpreted. In this study, there is a direct citation of the participants' views, preserving the authenticity of the data. Besides, the researcher used a sampling method appropriate to the nature of the study to show the variability and richness of the subject.

The opinions of the educators participating in the study on the main headings of technological leadership and their performance indicators were analyzed using content analysis technique. In this process, firstly the interview records were transferred to a plain writing and then these written texts were read carefully by the researcher more than once and the participant opinions were included in the categorized themes. The significant citations about the main headings and performance indicators were selected and links within the text and between the texts were established. In this study participants were coded as L1-L25 (Lecturer) with the principle of identity protection.

### 3. Findings

The findings were categorized under seven main headings; as "Learner", "Leader" and "Citizen" under the empowered professional theme and as "Collaborator", "Designer", "Facilitator" and "Analyst" under the learning catalyst theme.

#### 3.1 The Empowered Professional

##### 3.1.1 Learner

The participants were asked the following question: "What do you do to continually improve your practice by learning from and with others and exploring proven and promising practices that leverage technology to improve student learning?"

The views on the implementation of this standard in Turkey revealed that it is suitable for Turkey, but a few emphasized the technological infrastructure and hardware problems. The expression of L1 from the participants reflect most of the research group:

*I try to keep myself as up-to-date as possible on issues related to my profession in the field of technology and information, and to pursue existing training programs. I follow good practices of other educational institutions serving in the same area. (L1)*

Some other opinions about the subject are as follows:

*We look for appropriate digital resources with my colleagues if I need to. We are also reviewing the digital platforms of foreign publishing houses and putting them into practice where they can make the most contribution to the learning process. (L8)*

*I can participate in Online Webinar trainings and make learning continuous at times outside school. I can easily track online videos and PDF documents related to ELT and archive them for my work. (L19)*

*I follow social media accounts (Facebook, Instagram, Twitter, etc.) of expert educators. I read articles and researches they suggest. I'm reviewing web sites recommended by SoFL students. I take in-service trainings and attend ELT conferences. (L17)*

### 3.1.2 Leader

The participants were asked the following question: “How do you seek out opportunities for leadership to support student empowerment and success and to improve teaching and learning?”

When the lecturers were asked their opinions on the implementation of this standard in Turkey, many were in favor. On the other hand, different modes of learning, equal access to learning opportunities and individual differences of students were emphasized. The view of L13 from the participants reflect most of the research group:

*I advocate equal access to educational technology, digital content and learning opportunities that will meet the needs of students who will study in different areas and have different interests. I emphasize the importance of technology and digital life in all areas of life as well as in education and encourage students giving practical examples of how to use technology in and after the education life. (L13)*

The instructors we interviewed stated that a shared vision was needed to support student achievement and improve learning, and that equal learning opportunities should be provided to students with different needs. Some opinions on this are as follows:

*I share the applicable technological methods, techniques and practices I have learned during the workshops or online trainings with my colleagues in the school so that they contribute to the overall quality of the education. I give students online resources where they can benefit, and some suggestions based on individual differences. I also share new and feasible digital resources that I have discovered. (L20)*

*I'm trying to help my colleagues with small or large-scale problems with digital equipment. I inform them about platforms such as Padlet, Kahoot, Wheeldecide and Google Classroom, and I emphasize the areas that can be useful to them. (L7)*

### 3.1.3 Citizen

The participants were asked the following question: “How do you inspire students to positively contribute to and responsibly participate in the digital world?”

As for the implementation of this standard in Turkey, most of the lecturers agreed; however, they mentioned particularly new topics such as copyright law and the Personal Data Protection Law, and problems during practice in Turkey. Participant L12 reflects most of the research group's opinion as follows:

*First, I encourage students to use social networks with a certain maturity and consciousness. I advise on the awareness levels of information pollution disinformation and the ability to analyze in the digital environment. I emphasize the importance of choosing reliable sources in their research. I explain the need to use technology on a broad basis without leaving the concept of learning as much as possible, and the need to pay attention to the privacy of personal information. (L12)*

There were also opinions about students from different backgrounds who are in a multi-socio-cultural environment and the students who are still lacking in digital literacy:

*Considering the students' financial situation and conscientious / moral / professional concerns, I explain that students should never enter pirate book sites and that it is a crime and against copyright law and tell them not to download illegal digital or audio books. (L25)*

*I make myself clear about the Personal Data Protection Law. I would also like them to do their part to protect the data about their friends and the classroom environment. I refer students to digital platforms as much as possible since it is now an indispensable part of learning process. (L2)*



### 3.2 The Learning Catalyst

#### 3.2.1 Collaborator

The participants were asked the following question: “How do you dedicate time to collaborate with both colleagues and students to improve practice, discover and share resources and ideas, and solve problems?”

The lecturers participated in the study agreed most on the appropriateness of this standard in Turkey and stated that only a few problems emerged in its application. The joint opinion in the working group was summarized by the participant L3:

*We work with our colleagues to exchange ideas and work on online sites that we use to find resources in our work. I have experiences with my students about using social media as material for ELT. In many ways I can communicate with colleagues and other educators sharing ideas. The messages that are received via the mail also consist of good examples and exercises that create awareness. I work in an institution where I can easily get answers when I ask questions or comment. In an environment where technology is naturally integrated, the motivation of students who already always use technology in their lives will not disappear. So instead of boring information transfers, courses are created together with students using technology. Integrating technology into the classroom allows them to trust themselves by showing what they can do to the students. (L3)*

#### 3.2.2 Designer

The participants were asked the following question: “How do you design authentic, learner-driven activities and environments that recognize and accommodate learner variability?”

Most of the lecturers agreed about the implementation of this standard in Turkey; however, they emphasized the incapability or shortage of digital tools, resources and digital learning environments for various reasons. Participant L10 reflects most of the research group's opinion as follows:

*I use technology to provide a digital environment that will provide personal access and development opportunities for students. I argue that technology contributes to learning by integrating everyday life and designing through online games, exercises, movies and music during the education process. Studies on how to better meet the learning needs of the students and the programs to be implemented in both classical and digital environments are discussed at general and group meetings, negotiations are held, and the defined work plans are put into practice. (L10)*

The concerns and difficulties relating to the implementation of this standard in Turkey is stated by L14 as follows:

*I believe that our institution should have a team that can work full-time on information technologies and use resources in line with the needs. The education and professional experience I have gained from this area shows that if there is no such team, the educator-student interaction will be extremely limited or problematic. To put it another way, it requires the presence of a team that provides technical support to the campus as well as to students who are willing and able to perform in a digital environment "to create learning experiences that will meet student diversity and needs". I find myself ineffective / unsuccessful as 'designer' where this infrastructure does not exist. I work best as a lecturer who encourages the use of existing digital platforms but does not even create / use its own course-shell. (L14)*

#### 3.2.3 Facilitator

The participants were asked the following question: “How do you facilitate learning with technology to support student achievement of the 2016 ISTE Standards for Students?”

All the lecturers agreed on the implementation of this standard in Turkey while a small part of them pointed out their personal inability to facilitate learning with technology that supports student achievement. The view of L2 reveals the general idea of the working group:

*With digital platforms running on all kinds of devices, we create an easily accessible learning atmosphere for students, making learning space independent and easy. By having the students*

*create presentations using technology, I aim to create a digital environment that will allow them to create content that they can use their creativity and to improve in both independent and group settings. (L21)*

The problems in managing the use of technology and student learning strategies in digital platforms, virtual environments, hands-on makerspaces or in the field was stated as follows:

*We have a digital platform designed for in-service use. Here, exercises are given to the students and the lessons are taught. The students can access this from outside the school or anywhere they want. But apart from that, I do not do anything about managing individual learning strategies. I do not think that there is a digital work platform in which students can express themselves without any fear of doing everything wrong. (L18)*

### 3.2.4 Analyst

The participants were asked the following question: "How do you understand and use data to drive your instruction and support students in achieving their learning goals?"

The lecturers participated in the study agreed most on the appropriateness of this standard in Turkey but stated that there are some problems related to using technology to design and implement a variety of formative and summative assessments that accommodate learner needs, provide timely feedback to students and inform instruction:

*I review any reports that are generated from the collected data in digital classes and follow the success of the students in the learning process. I make their learning more effective by giving quick and detailed feedbacks after their presentations. I try to show the competences of the students and to offer alternative ways to reflect what they learn using technology and to offer them opportunities to help them reach their goals. (L22)*

*At the personal level, I cannot say I specifically analyze certain data. I observe my performance to raise my low scores I have achieved in the light of the annual reports given by our school (teacher performance evaluation, annual evaluation, etc.) (L17)*

## 4. Conclusion and Recommendations

The opinions of the lecturers participated in this study show that these standards are mostly suitable for Turkey. However, the data obtained from individual interviews reveals the issues that may be experienced in the implementation of these standards.

As for the main headings of "Learner", "Leader" and "Citizen" under the *empowered professional theme*, it is seen that lecturers generally agreed on these standards together with their performance indicators. However, the participants also stated that some performance indicators are not suitable to conditions in Turkey. The lecturers claimed that the processes of developing a technology vision and programs that comply with the conditions of Turkey in this process is the most difficult problem.

The technological inadequacy of school administrators and inability of elderly lecturers to be open to innovations of is one of the most frequently mentioned problems. Although not a phobia, fear and hesitation to use new technology, even the existing technology, can be seen in every institution and every age. Therefore, initiatives should be made to integrate the technology into the whole functioning of the school, and in-service training in education technology should be given a great deal of value.

This study also found a difference between foundation and state universities. The market competition and differentiation policy forces technological inclusion into the vision of teaching staff at foundation universities and thus enhances their technological competence. On the other hand, in state universities, although technology is being tried to be integrated into foreign language education, this goal is limited due to various reasons, especially for financial reasons.

It will be possible to create an effective digital age learning culture in foreign language schools and this culture will be strengthened in the virtual or real environment of the students. As a technological leader, educators need to define their environment very well. Informational meetings or trainings can be organized in the school with the participation of the lecturers and students in the school so that the digital age learning culture in the school can be internalized by the students.

When it comes to the main headings of "Collaborator", "Designer", "Facilitator" and "Analyst" under the *learning catalyst theme*, the participants mostly agreed on these standards although some of their performance indicators may not totally be in line with the conditions in Turkey.

The inadequacy of communication between school administrators, educators and students at schools is one of the voiced issues. For these performance indicators to be realized, online and face-to-face sessions where school principals and instructors can share their problems, their own practices and experiences should be increased. In this way, all the school employees' technological competence problems are solved, and a positive step is taken to develop their vision and to think creatively. Some problems in designing goals were highlighted by the educators involved in the study. It has been reported that existing technological systems in schools or educators' technological leadership levels do not overlap with academic programs. At this point, it must be made clear that the technological infrastructure of the schools or the technology systems planned to be established in the future comply with the educational programs.

Today, Turkey is in the transition period of technological leadership. So, especially in schools of foreign languages, "the use of information technology and ethical use of technology" should be given priority issues. A regulation should be established by the Council of Higher Education on the use of technology in areas such as teaching, research, communication and management, and ethical rules should be recognized.

Another shared view of the participants involved in the study is the need for a unit that will provide technical and training support for the use of the technological infrastructure that is present in each school and which is planned to be installed later. These educational technology units can set the planned technology expenditures as well as the strategy of the school in this area. The findings of the research also show that the issue of technological leadership needs to be addressed with instructional leadership, ethical leadership, social leadership, visionary leadership and transformational leadership as well as with other standards of the ISTE for students, educational leaders and coaches.

The purpose of this study was to examine the views of lecturers at Schools of Foreign Languages on the National Educational Technology Standards (NETS-E) developed for educators by the International Society for Technology in Education (ISTE), and to evaluate the compliance of these standards in Turkey from their perspective. More comprehensive researches including more diverse samples could pave the way to determine technology leadership standards for Turkey in the future. Findings and results of this study can be used not only for teaching staff in a foreign language school but also for structuring a post-graduate program or in-service programs that all academicians can benefit from. This is because the development of training programs in which all educators will gain technological leadership competencies is of great importance today. Technology is now one of the indispensable components of contemporary educational systems. In this context, the indicators and findings in the study can be examined in detail in terms of socioeconomic and cultural variables and used in future researches. Therefore, it is thought that this research can shed light on future multidisciplinary studies.

## 5. References

- Afshari, M., Bakar, K. A., Luan, W. S., Samah, B. A., & Fooi, F. S. (2009). Technology and school leadership. *Technology, Pedagogy and Education*, 18(2), 235-248.
- Akbaba-Altun, S., & Gurer, M.D. (2008). School administrators' perceptions of their roles regarding information technology classrooms. *Eurasian Journal of Educational Research*, 33, 35-54.
- Alkan, A., & Durmus, O. (2013). İngilizce öğretmenlerinin derslerinde bilisim teknolojilerini kullanma durumlarına ilişkin görüşleri. *Eğitim ve Öğretim Araştırmaları Dergisi*, 2(1), 110-116.
- Anderson, R.E., & Dexter, S. (2005). School technology leadership: An empirical investigation of prevalence and effect. *Educational Administration Quarterly*, 41, 49-82.
- Arslan, H. (2018). *An Introduction to Education*. London: Cambridge Scholars Publications.
- H.Arslan & G.Rata. (2013). *Multicultural Education: From Theory to Practice*. London: Cambridge Scholars Publishing.

- Bauer, J., & Kenton, J. (2005). Toward technology integration in the schools: Why it isn't happening. *Journal of Technology and Teacher Education*, 13(4), 519–546.
- Beytekin, O. F. (2014). High school administrators' perceptions of their technology leadership preparedness. *Educational Research and Reviews*, 9(14), 441-446.
- Byrom, E., & Bingham, M. (2001). *Factors influencing the effective use of technology for teaching and learning: Lessons learned from the SEIR\*TEC intensive site schools* (2nd ed.). Greensboro, NC: University of North Carolina at Greensboro.
- Dinham, S. (2005). Principal leadership for outstanding educational outcomes. *Journal of Educational Administration*, 43(4), 338–356.
- Felton, F.S. (2006). *The use of computers by elementary school principals*. (Unpublished doctoral dissertation). Virginia Polytechnic Institute and State University.
- Fiske, E., & Hammond, B. (1997). Identifying quality in American colleges and universities. *Planning for Higher Education*, 26(1), 8–15.
- Flanagan, L., & Jacobsen, M. (2003). Technology leadership for the twenty first century principal. *Journal of Educational Administration*, 41(2), 124–142.
- Gurol, A., Yavuzalp, N., Bagcaci, F. ve Serhatlioglu, B. (2009). *Ogretmen adaylarina gore egitim fakultelerinde egitim teknolojisi standartlari ve performans gostergelerinin uygulanma durumu (Firat Universitesi ornegi)*. Paper presented at 9. Uluslararası Egitim Teknolojisi Konferansi (IETC), Ankara.
- ISTE (2017). ISTE Standards for Educators e-book, ISBN-13: 978-1564843951, ISBN-10: 1564843955.
- Miles, M., & Huberman, A. M. (1994). *Qualitative data analysis*. London: Sage.
- Mumtaz, S. (2000). Factors affecting teachers' use of information and communications technology: A review of the literature. *Journal of Information Technology for Teacher Education*, 9(3), 319–342.
- Nomass, B. B. (2013). The impact of using technology in teaching English as a second language. *English Language and Literature Studies*, 3 (1), 111-116.
- Smith, J. (1994). *Collective intelligence in computer-based collaboration*. Hillsdale, NJ: Lawrence Erlbaum Associates.
- Tanzer, S. (2004). *Mesleki ve teknik ogretim okul yoneticilerinin teknolojik liderlik yeterlikleri*. (Yayinlanmamis Yuksek Lisans Tezi). Abant Izzet Baysal Universitesi, Sosyal Bilimler Enstitusu, Bolu.
- Turan, S. & Sisman, M. (2000). Okul yoneticileri icin standartlar: Egitim yoneticilerinin bilgi temelleri uzerine dusunceler. *Balikesir Universitesi Sosyal Bilimler Enstitusu Dergisi*, 3(4), 68-87.
- Whitehead, B.M., Jensen, D.F.N., & Boschee, F. (2003). *Planning for technology: A guide for school administrators, technology coordinators, and curriculum leaders*. Thousand Oaks, CA: Corwin Press.
- Williams, D., Coles, L., Wilson, K., Richardson, A., & Tuson, J. (2000). Teachers and ICT: Current use and future needs. *British Journal of Educational Technology*, 31(4), 307–320.



# **A Study on the Motives behind Vocational School Students' Preference of Culinary Arts Program and Their Opinions about the Program**

Ahu Sezgin, Emrah Koksal Sezgin

## **1. Introduction**

Culinary arts used to be under the domination of chefs who established an oppressive hierarchy and did not share their culinary secrets. Today, this is changing, mostly thanks to culinary arts schools. These schools offer culinary arts education, which is customized on sectoral basis, in a shorter period of time compared to traditional long-term education. Culinary schools have not only trained qualified personnel but also promoted cookery as a profession (Hughes, 2003: 10).

It is believed that college applicants usually do not realize the significance of their decisions when it comes to the choice of profession. Most young adults are trained for the jobs they do not want under the influence of their families, friends, and acquaintances. As a result, they tend to leave their profession and practice professions other than the ones they are trained for. Cookery is among the professions which require inner motivation to be practiced effectively (Erdinc and Kahraman, 2012: 230).

This study aims at investigating the opinions of culinary arts students who complete an associate degree in order to obtain the qualifications that help them do research, keep up with the changing situations and developing technologies, contribute to the national economy, and provide skilled labor.

## **2. Literature**

Profession can be defined as the knowledge and experience accumulated through a set of social rules and education so that individuals sustain their lives. Primarily considered a number of activities to make money, profession is also a way of using skills, personal development, and self-realization (Koroglu, 2014:139). A study conducted by Sarikaya and Khorshid (2009) examines the factors that affect students' choice of profession. According to the results of the study, the primary reasons of choice are despair, other people's suggestions, choosing programs for the sake of appearances, and the impression that the chosen profession is favorable.

In Turkey, developments in tourism industry highlight the need for qualified personnel in food and beverage sector. Training qualified chefs can provide labor supply. The facilities offered by educational institutions where students obtain culinary arts qualifications play a fundamental role for creating a self-image as a competent professional and developing a positive attitude towards the job (Ozturk and Gorkem, 2011).

Culinary arts program aims at training chefs who can plan menus, control food cost, produce safe and healthy food, cook and serve dishes properly, and use various culinary skills. According to standard classification of occupations (2009), chefs are trained to prepare, season, and cook salads, soups, fish dishes, meat dishes, vegetables, desserts, and other dishes; plan the workflow, price the menu items, order consumables, and keep the records (Cheng et. al, 2014).

Duties of a chef are as follows (Harbalioglu and Unal, 2014):

- Prepare and serve dishes
- Prepare menu items on time, in the right serving sizes, and in the right quality
- Follow hygiene and sanitation rules
- Protect the equipment in their charge
- Take delivery of food
- Practice workplace safety rules
- Perform the tasks assigned by the superiors

Cookery is a profession which requires skills, planning, and self-devotion. The popularity of cookery is increasing, so cookery students' perception of the profession is becoming a significant subject of study (Kurnaz et. al. 2014). Culinary arts program offers practice-oriented education and its objective is to train individuals who have professional and academic qualifications; are creative, productive, innovative, and visionary. They should operate at national and international levels. They can work in hotels, catering firms, chained-brand hotels, pastry industry, food and beverage business, and kitchens of private and public enterprises.

### 3. Method

This study is qualitative phenomenological research. Data was collected through interviews. The data was analyzed by means of content analysis. Below are the detailed explanation about the sampling, data collection tool, and the validity and reliability of the data collection tool.

#### 3.1. Sampling

The sample of the study was drawn from Adnan Menderes University, Davutlar Vocational School, Culinary Arts Program. 5 female and 5 male students participated in the study. The sample was selected by means of convenience sampling method. The primary benefit of this method is the fact that it provides speed and convenience for the researcher (Simsek and Yildirim, 2000).

#### 3.2. Data Collection Tool, Validity and Reliability

Data was collected through semi-structured interviews. The interview questions were assessed for validity on various levels. After literature review, a question pool was created with the questions that were thought to identify the students' problems and opinions. The questions were reviewed by three specialists. The participants were informed that the study was based on voluntary participation and that their answers would remain confidential. Another criterion is that the data was obtained by means of in-depth interviews.

The reliability of the study was provided by directly quoting the student opinions in the results section.

The interview form was revised according to the specialists' views. The final version of the interview form includes 6 questions to find out the reasons for students' choosing culinary arts program, the main influences on their university preference (family, secondary education, friends, teachers etc.), whether the courses in the culinary arts program are adequately-designed, whether the education they receive complements students' job training, and whether the profession is compatible with their personality and has a place in their future plans. The interviews were transcribed by the researchers.

### 4. Results

In this study, which aims at investigating the motives behind culinary arts program students' choice of profession and their opinions about the program, semi-structured interviews were used for collecting data. The first interview question is about the reasons why students prefer culinary arts program and whether their preference is based on their free will. The participants stated that they studied cookery during their secondary education and wanted to continue their field of study. They also stated that they were interested in cookery and chose the profession of their own free will. Some of the answers are as follows:

*E5: I had already been practicing cookery at high school. However, we weren't trained adequately at high school. I wanted to better myself at college.*

*K1: I wasn't interested in cookery before college. My preference was based on my university exam score. I tried to choose the best alternatives within my score range. I was also seeking a profession with job guarantee such as education, military etc. These sectors provide various job opportunities. So does the cookery. That's why I chose this program.*

*E4: I had been dreaming about this profession since my childhood. The main reason why I am here is the presence of experienced trainers and lecturers.*

## A Study on the Motives behind Vocational School Students' Preference

*K5: I received cookery education at high school. I had chosen that school because of my high school entrance exam score. Then I came to like the job and chose to study cookery at college.*

The second question of the interview asks whether the courses in the culinary arts program are adequately-designed for the students. When the answers are examined, it is seen that the participants find the theory classes adequate. However, they demand more practice sessions. Participants also state that they cannot afford some expensive food (e.g. lobster) and cannot practice preparing or cooking these foods. Another concern is the lack of English classes during the first year of college education. This, they say, causes some adaptation problems and difficulties when they take English for Occupational Purposes classes during their second year. Some of the answers can be seen below:

*E2: Sometimes we cannot find or buy some essential ingredients. Practice sessions become inadequate. We cannot learn some cooking techniques just because we cannot buy the ingredient. I think this is our biggest problem.*

*K4: I believe theory classes are adequate. They lay the foundation for us. We should have had more practice sessions during our first year. The second year is adequate though.*

*K2: It was good for us to have theory classes first. That provided a good foundation. I find the elective courses inadequate. They were not relevant to culinary arts. It was bad for us not to have English classes during the first year. It was shocking to have a demanding English course at the second year.*

The third question tries to find out whether the education they receive complements participants' job training. The participants think their college education complements their job training. However, they also see that the chefs and chef de parties in the kitchens where they receive their job training impose their own experience and practices upon students, even if these practices differ from the ones that the students learn at college.

*K1: I think what we learn at college is definitely adequate, but during the job training, we can never practice what we learn at college. We cannot act out of the hierarchy. There are very strict rules, but I cannot see anything related to the training we receive at school. Time and money is put before workplace safety and we are not allowed to practice the theory we learn at school. What we do at school is above the job training standards because we receive high-quality education.*

*K3: We didn't take pastry classes during the first year. My job training taught me pastry and baking techniques. I worked at the pastry section and prepared myself for my second college year. This also improved my hand skills. I am where I want to be.*

*E1: I think college education and job training experience differ significantly. There is no place for mistakes in the job training. Our thoughts are not important there. If we had done the job training first, we would have been disheartened.*

The future plans of culinary arts students include transferring their college education to undergraduate education.

*K5: My current goal is to get an undergraduate degree. I want to study nutrition and dietetics. I want to continue my education and become a conscious dietician who knows how to cook.*

*K1: If I decide to continue my career as a chef and work with visionary chefs, I will go abroad. I think this is the only solution. The chefs in Turkey hinder the young chefs from development. They want to overshadow us. They train young chefs for the competitions, but they don't share their secrets in a hotel kitchen. Gaining restaurant experience, especially abroad, is very important. I believe culinary arts education is very important. This job will always be on my mind.*

*E3: I want to continue my career as a pastry chef. I am interested in pastry and baking techniques. My career goal is to be a good pastry chef. I want to be an innovative and successful chef.*

*E4: I want to design my own kitchen and open a restaurant. I know I have to work hard for this. I must work with successful chefs. I got job training in a decent place. I wish I could continue to work in such good restaurants.*

The last interview question asks whether the profession is compatible with their personality.

*E5: Actually, I think I am talented, but I don't think this job is right for me. I am discouraged due to the people I've worked with so far. I am educated for this profession at college, but self-taught and experienced chefs impose their opinions upon us and they do not develop themselves. I can't help but worry about my future career.*



*K3: I think this profession is suitable for me. I was born to do this job. We have a family-run restaurant. My grandfather, my father, and my mother are all chefs. I grew up in this restaurant. I am aware of both the advantages and the difficulties of this job. Because I have been cooking with my father since my childhood, this job is a passion for me. I will take over the business from my father.*

*K2: The main point is to be happy and satisfied. I know this profession is difficult for women. I would like to work in a la carte Turkish restaurant. First, I wanted to have essential kitchen experience. I wanted to overcome some difficulties in a hotel kitchen. I would like to work in a la carte restaurant, but it is difficult for a married woman. Working in the morning is better. Cookery is a difficult profession due to working hours.*

*E2: It seems compatible. Sometimes it is wearisome to do the same thing again and again. But I manage to motivate myself. I believe things will be better. I can do it. I follow the works of famous chefs. I see good examples around such as our teachers. I firmly believe that anybody can be successful as long as they believe in themselves.*

## 5. Conclusion

This study, which aims at investigating culinary arts students' opinions about the profession of cookery, is qualitative phenomenological research. Data was collected through semi-structured interviews which were designed with the help of specialists' views. The data was analyzed by means of content analysis. The sample of the study was drawn from Adnan Menderes University, Davutlar Vocational School, Culinary Arts Program. 5 female and 5 male students participated in the study.

The interview forms were used to find out the reasons for students' choosing culinary arts program, the main influences on their university preference (family, secondary education, friends, teachers etc.), whether the courses in the culinary arts program were adequately-designed, whether the education they received complemented students' job training, and whether the profession was compatible with their personality and had a place in their future plans.

When the participants' answers were analyzed, it was seen that the ones who received cookery training at high school were familiar with the nature of the profession and chose the culinary arts program consciously in order to improve their skills further. Those who did not receive cookery training chose the culinary arts program because it would offer job guarantee, create opportunities to socialize and have fun, encourage innovation and provide contemporary working environment. Both groups chose the program of their own free will. The biggest problem for the participants was the expenses. They stated that their budgets were limited, and they could not afford some food and drinks used in the practice sessions. The limited finances not only hindered professional development but also demotivated the students. Another problem posed by the program, according to the participants, was the lack of English classes during the first year of study. Their level of knowledge was inadequate for the English for Occupational Purposes course taken during the second year of study. The question about the contribution of their college education to their job training revealed that the theory classes and practice sessions were adequate for the job training. However, they witnessed that the experienced chefs in professional kitchens imposed their own practices and ignored the students' suggestions. Despite all the difficulties, especially the ones caused by the strict hierarchy in the kitchen, the participants thought cookery was compatible with their personality. They stated that they would like to continue their career and work in different food and beverage industries.

The road to success in cookery is paved by interest and motivation. Therefore, students need support from the educational institutions. As for the businesses, they can create such an organizational climate that it continues professional training and encourages professional development. According to the professionals in tourism industry, the most important skills and qualifications that the staff in tourism businesses should have are "the ability to put theory into practice, experience, education, and foreign language skills" (Yilmaz and Tanriverdi, 2017). As the participants stated, the number of English courses in the program was insufficient. English classes can be added to the course list of the first year of study.

The study was conducted exclusively with the participation of associate degree students. A similar study can be conducted with undergraduate degree students, especially with the ones studying

Gastronomy and Culinary Arts and Food and Beverage Management. It is assumed that such a study will be complementary to the current study.

## 6. References

- Cheng, M., Ogbeide, G., C., Hamouz, F., L. (2011). The Development of Culinary Arts and Food Science Into a New Academic Discipline—Culinology, *Journal of Culinary Science & Technology*, 9, 17–26.
- Erdinc S. B., Kahraman, S. (2012). Turizm Meslegini Secme Nedenlerinin Incelenmesi, *VI. Lisansustu Turizm Ogrencileri Arastirma Kongresi*, 229-237.
- Gorkem, O., Yuksel, O. (2011). Mutfak Dali Ogrencilerinin Mesleki Yeterliklerinin Degerlendirilmesi: Otelcilik ve Turizm Meslek Lisesi Ogrencilerine Yonelik Bir Uygulama Isletme Arastirmalari Dergisi, 3(2),69-89.
- Harbalioglu, M., Unal, I. (2014). Ascilik Programi Ogrencilerinin Mesleki Tutumlarinin Belirlenmesi: OnLisans Duzeyinde Bir Uygulama, *Turizm Akademik Dergisi*, 1(1), 57-67.
- Hughes, M. H., (2003). *Culinary Professional Training: Measurement Of Nutrition Knowledge Among Culinary Students Enrolled In A Southeastern Culinary Arts Institute*. Unpublished Ph.Doctorial Thesis, University of Alabama.
- Koroglu, O. (2014). Meslek Secimi Ile Kisilik Ozellikleri Arasindaki Iliskinin Belirlenmesi: Turizm Rehberligi Ogrencileri Uzerine Bir Arastirma, *Suleyman Demirel Universitesi Iktasadi Ve Idari Bilimler Fakultesi Dergisi*, 19(2), 137-157.
- Kurnaz, A., Kurnaz, H. A., Kilic, B. (2014). Onlisans Duzeyinde Egitim Alan Ascilik Programi Ogrencilerinin Mesleki Tutumlarinin Belirlenmesi, *Mugla Sitki Kocman Universitesi Sosyal Bilimler Enstitusu Dergisi*, (32), 41-61.
- Sarikaya, T., Khorshid, L (2009). Universite Ogrencilerinin Meslek Secimini Etkileyen Etmenlerin Incelenmesi: Universite Ogrencilerinin Meslek Secimi”, *Turk Egitim Bilimleri Dergisi*, 7(2), 393-423.
- Simsek, H. Yildirim, A. (2000). *Sosyal Bilimlerde Nitel Arastirma Yontemleri*. Ankara: Seckin Yayin evi.
- Yilmaz, A., Tanriverdi, H. (2017). Ascilarin Meslek Uyumu ve Meslek Algisi Duzeyleri Uzerine Bir Arastirma, *Karabuk Universitesi Sosyal Bilimler Enstitusu Dergisi*, 7 (2), 621-639.



# Development Study of School Principals' Coaching Skills Scale

Ayşe Özge Kupeli, Mustafa Aydın Basar

## Introduction

The economic environment of the 21<sup>st</sup> century has brought about new difficulties in terms of continually changing in order to meet new and increasing demand in areas such as accountability, competition, participation in decision making, cooperation and leadership for educational institutions just as much as they have for globalization, technological development, all systems and organizations (Yirci, Ozdemir, Kartal and Kocabas, 2014; Robertson, 2009). Overcoming these difficulties and developing their schools is a priority for every school principle (Krasnoff, 2015 ref. Wise & Hammack, 2011). In order to achieve this, it is necessary for a school, which also has to move towards an understanding of a learning organization, to do so together and as a collective entity by focusing on learning for everyone. This is a difficult process for schools which are quite resistant to change, and which requires brave leadership, an attractive vision and for all the students to be continually motivated to reach a future where they reach their maximum potential. This process can be viewed as a necessary evolution for schools to have a culture of continual improvement and development (Wise & Jacobo, 2010).

In a critical point in the development of teaching by principals is that only managing a school's processes and resources is not sufficient. There needs to be idealistic visionary educators, program development specialists, evaluation specialists, discipline supervisors, community founders, public relations specialists, budget analysts, building managers, special program coordinators and education policy specialists with legal knowledge who have

vision and a focus on the future. In addition to meeting the conflicting demands of teachers, students, parents, those in higher management and local managers, school principals are expected to be sensitive to the needs of students who occupy a space in a very wide juncture (NASSP&NAESP, 2013).

The role of principals as managers, leaders and agents of change is expansive and they have the responsibility of working with an extensive list of stakeholders from students, parents, teachers and union officials to school management, teachers and local business owners (Mangin, 2007). As a result of these extensive responsibilities, school principals fulfil a very significant and critical function and should, to meet the needs their duties necessitate, employ a range of facilitative and balancing strategies. Coaching, which has a management philosophy based on making learning easier, can be used by principals by adopting behaviors which are conducive to learning and developing skills related to workers' occupations. This is because experimental research has shown that they are a powerful developmental practice based on coaching for principals to facilitate learning and increase the performance of workers (Ellinger & Bostrom, 1999; Ellinger, Ellinger, Bachrach, Wang & Bas, 2010).

As coaches, school principals develop a vision and set goals. They create a strong team of teachers and motivate them to develop their skills and continually learn. They evaluate their performance and inspire them to develop by looking at data (Trail, 2000; Yirci et.al., 2014).

## Conceptual Framework

The concept of coaching is not a new fact. The term 'coach' was first used in the 16<sup>th</sup> century to define a specific carried vehicle which took people to where they wanted to go. The root of the term coach is to *take a valuable person to where they want to go*. The idea of a correct journey to the desired place summarizes the goal of coaching from many perspectives. Coaching has throughout history been associated with people reaching their professional and personal goals, improving their performance and developing their personal potential. The International Coach Federation (ICF) defines coaching, in the uncertain and confusing environments of today, as a partnership based on a creative process where

the ideas of the coaches are awoken and where they are encouraging to raise their personal and professional potential to the highest levels. This process develops leadership skills of those receiving coaching and helps them to develop their professional and life styles while displaying their potential (ICF, 2017).

The earliest efforts directed at discovering coaching as a management function appeared in the 1950's with the work of Myles Mace. Myles Mace thought coaching was a valuable and obtainable management skill (Evered & Selman, 1989). As time passed, change in organizational life became an unavoidable situation together with global, economic and technological developments. In the 21<sup>st</sup> century, organizations began to give space to new concepts in organizational life such as workforce diversity, the high-performance organization, restructuring, authorization, self-managing teams, learning organizations and customer services in order to meet the difficulties created changing business conditions, technological developments and by global competition (Ellinger, Ellinger & Keller, 2003; McLean, Young, Kuo, Tolbert & Larkin, 2005). While organizational practices focused on workers and processes that gained a superiority based on constant competition, new team-based models not connected to position and based on delegating took the place of management models established upon directing and control. These new models required that managers adopted new behaviors which facilitated workers' learning and development by encouraging them. Organizations use coaching practices for a wide range of developmental purposes such as improving worker performance, developing the careers of workers, developing management and leadership, formulating strategies and organizational change. In management, coaching practices can be a part of managers' responsibilities or can be a service procured externally of the organization from professional coaches (Kim, 2010). Researchers assert that managers have to take on a new role as a coach to let go of some of their authority and control so as to improve worker performance. Managers' coaching behaviors attract even greater attention due to the gradual transfer of responsibility for workers' development and learning. It is necessary for coaching to gradually become a more important developmental approach in order to ensure the long-term learning, job satisfaction and loyalty to the organization (Ellinger et.al., 2003; Redshaw, 2000).

Coaching-based management is a management technique based on managers' implementation, development and cooperation skills with the knowledge of how and under which conditions workers develop (in general) and develop specific skills. Coaching is not a method to solve one-off problems; it is a method for developing worker performance and raising the skills they have to the highest levels (Orth, Wilkinson & Benfari, 1987). A popular organizational development strategy, it is a governance philosophy that attempts to change the relationship between the manager and worker. It includes making it easier for managers to display the behaviors which enable workers to learn and develop skills related to work (Anderson, 2013; McLean et.al., 2005). It focuses on the discovery of actions which enable the strengthening of workers to make them more productive by increasing their potential and reducing alienation brought about by their control of workers. The core of coaching is creating a partnership committed to producing results and the realization of a vision, communicating to encourage workers to take action, honoring the uniqueness of workers and feeling the need to go beyond what is reached (Evered & Selman, 1989; McLean et.al., 2005).

Traditionally, school management focuses on directing the operation and the management of tasks and process within the school environment such as setting goals, budgeting and resource allocation, maintaining an orderly environment and evaluating teachers. As educational foci on accountability, school development and student success intensified, school management became multi-layered and was gradually given greater responsibility (Duncan & Stock; 2010). Many school managements are, with the support of principals, attempting to create an educational community based on cooperation which reviews and develops practices so as to meet the difficult task which has been placed upon them. This process can begin with basic area coaching for student work to both increase the professional development of teachers and ensure development throughout school (Niddus & Sadler, 2011). The coach school principal is a principal who encourages teachers to develop a high-performance school by giving importance to coaching practices which make learning easier (Ellinger et. al., 2003).

Coaching-based management can be used to increase the development of teachers as individuals and schools systematically. The foundation of coaching in the professional development of teachers includes support and training through cooperative, non-judgmental efforts. Researchers show that coaching is an effective professional development method for the encouragement of the transfer of new skills and knowledge to application, introducing the use of innovative techniques, and the development of new teaching strategies by teachers, as well as the creation of good professional relationships between teachers (Ai & Rivera, 2003). Coaching-based management at schools can be considered as an effective professional development program for principals to use at work, is result-focused for teachers and differentiated according to teachers' and students' needs as well as being cooperative, continual, reflective, evaluation-based. It ensures a contribution to school development through the development of teachers. The coaching process, implemented for development of both teachers and schools, is a cyclical process with planning-implementation-tracking-re-examination (correction) and evaluation steps in its sub-cycles such as is in Figure 1.



Figure 1. Coaching-based school development process (Laba, 2011)

These cycle stages which summarize school development through coaching is a guide for school principals with regard to their changing responsibilities and rolls throughout the process (Laba, 2011). These stages also define the techniques, tools and skills that school principals will use throughout the coaching process. It is necessary for school principals to possess basic coaching skills such as establishing partnership-based relationships with teachers, effective listening, the ability to observe, the ability to ask powerful questions and the ability to give constructive feedback in order for them to be able to manage the coaching process in an effective manner. The coaching-based school management method is an in-house coaching practice and in-house coaches need to possess information related to the organization's structure, processes, culture and way of working (Baltas, 2011). Coaching, which provides the one-on-one help for teachers' work with regard to the needs they have concerning educational matters identified for them, is based on the belief that they will identify and strengthen their own educational methods when the opportunity is given to them. As a coach, the school principal helps teachers with the development of the practices by being involved in specifying goals and providing constructive feedback. The coaching-based school method supports a culture of cooperation and can be used a school development strategy (Ronald, 2012).

### Aim of the Study

In this study, we have aimed to develop a valid and reliable quantification tool which describes the proficiencies of school principals based on the views of teachers.

## Method

### Population and Sample / Working Group

The study population of this research is made up of 5501 teachers working in different branches in formal pre-school, primary school, middle school and high school levels in Canakkale during the 2016-2017 academic year (Canakkale National Education Directorate, 2016). The research's sample group was determined with the proportional cluster sampling method so that the sample group was of a composition which is able to represent the population. As the working population is made up of a cluster with a similar function, clustering was performed by determining the schools where the teachers worked, not the teachers who participated in the study. Schools in villages were not included in the cluster group while schools with an autonomous school principal were chosen.

Cluster size was calculated with the cluster size identification formula developed by Cochran (1962) with a tolerance level of 0.05.  $N= 5501$  (Population size),  $d= 0.05$  (Attitude level),  $t= 1.96$  (table value based on a tolerance level of 0.05),  $PQ= (0.50)$ .  $(0.50) = 0.25$  with (Cluster percentage for maximum cluster size) equaling  $n=$  Cluster size

$$n = \frac{t^2(PQ)}{d^2} \text{ if } = \frac{(1,96)^2(0,25)}{(0,05)^2} \cong 360$$

$$1 + \frac{1}{N} \frac{t^2(PQ)}{d^2} \text{ if } = \frac{1}{1 + \frac{1}{5501} \frac{(1,96)^2(0,25)}{(0,05)^2}} \cong 360$$

(ref. by Balci, 2010). This value represents seven percent of the population. Taking the possibility of lost data into account, including more teachers in the sample was planned. Sampling began by choosing the districts to be included in the research. These districts were separated into three groups taking their geographical characteristics and socio-economic development levels into account (Table 3) (DPT, 2004).

Table 3

*Grouping of Canakkale's Districts Based on Socio-economic Development Level*

Districts in Socio-economic Development Group 2	Districts in Socio-economic Development Group 3	Districts in Socio-economic Development Group 4
Merkez ✓	Eceabat	Yenice ✓
Bozcaada	Ezine	
Gokceada	Biga ✓	
Can	Lapseki	
Gelibolu ✓	Ayvacic ✓	
	Bayramic	

✓ Selected districts

From the groups created according to the districts' socio-economic development level, Gelibolu, Biga, Ayvacik and Yenice districts, together with the Merkez district, were included in the sample group. Even though they are in the same development group, districts from different regions were selected. The population was divided into sub-populations according to the chosen districts. The number of schools and teachers to be included in the sample were impartially selected by aiming to reach at least ten percent of the schools at various levels and in the sub-populations and of the teachers who work at these schools. 48 schools and 586 teachers were selected for the sample group. The number of schools and teachers in the sub-population included in the sample are in Table 4.

In line with data deemed suitable for evaluation, the research's sample is made up of a total of 575 teachers with 21 pre-school, 183 primary school, 163 middle school and 208 high school teachers who

worked in organized, formal educational institution during the 2016-2017 academic year. As it stands, the sample group forms 10.45% of the 5501 teachers who worked at various levels in Canakkale Province during the 2016-2017 academic year. The teachers who are in the sample group represent a population with a tolerance level of 0.04 (Balci, 2010 ref. Anderson, 1990).

Table 4

*Distribution of Schools and Teachers in the Sample Group According to District*

Districts	Number of schools selected for the sample group	Number of teachers in sub-population	Number of teachers included in the sample group	Representative percentage of teachers in the sample
Ayvacic	7	229	46	19.65
Biga	14	1032	137	13.98
Gelibolu	9	451	60	12.86
Merkez	11	2259	294	12.88
Yenice	7	261	49	18.00
TOTAL	48	4232	586	13.50

70.26 percent of the participants in the sample group are female and 29.74 are male. 17.74 percent have between 0-5 years', 21.56 percent have between 6-10 years, 20 percent have between 11-15 years of seniority. 19.83 percent have between 16-20 years and 20.87 percent have 21 years or more seniority. 31.8 percent work in primary schools, 28.35 work in middle schools, 36.17 percent work in high schools and 3.65 percent work in pre-schools. The personal and professional characteristics of participating teachers are in Table 5.

Table 5

*Personal and Professional Characteristics of Participating Teachers (n=575)*

Groups	Frequency	Percentage
<b>Gender</b>		
Female	404	70.26
Male	171	29.74
<b>Professional Seniority</b>		
0 – 5 years	102	17.74
6 – 10 years	124	21.56
11 – 15 years	115	20.00
16 – 20 years	114	19.83
21 years and above	120	20.87
<b>School Level</b>		
Pre-school	21	3.65
Primary School	183	31.83
Middle School	163	28.35
High School	208	36.17

### Development of Scale Structure

Domestically and internationally published studies were reviewed by examining the literature related to the subject and an item pool directed at the research's problem was generated. Items that could not supply validity within the scope were cancelled after investigating the item list. A scale to define teachers' views on the proficiency of school principals' coaching was scaled as follows: "1= Never, 2= Rarely, 3= Sometimes, 4= Most of the time, 5= Always". A pilot program was conducted with 201 teachers who worked at schools that were not included in the sample group after the necessary



corrections were made. The personal and professional characteristics of participating teachers in the pilot program are in Table 6.

Table 6

*Personal and Professional Characteristics of Participating Teachers in the Pilot Program (n=201)*

<b>Groups</b>	<b>Frequency</b>	<b>Percentage</b>
<b>Gender</b>		
Female	142	70.65
Male	59	29.35
<b>Professional Seniority</b>		
0 – 5 years	20	9.95
6 – 10 years	46	22.89
11 – 15 years	44	21.89
16 – 20 years	41	20.40
21 years and above	50	24.88
<b>School Level</b>		
Pre-school	6	2.98
Primary School	68	33.83
Middle School	33	16.42
High School	94	46.77

After validity and reliability analyses were performed on the data obtained from the pilot program, we moved to implementation to gather the data to be used to obtain findings by making the necessary corrections and edits in line with the results of the analyses as well as the views and recommendations of the teachers who participated in the pilot program.

### Data Analysis

The scope and validity of the structure of the scale in the study was investigated. A hypothetical framework was created by investigating the field's literature in order to ensure the validity of the scope. Exploratory Factor Analysis (EFA) and Confirmatory Factor Analysis (CFA) were performed in order to examine the validity of the structure. The Kaiser Meyer-Olkin (KMO) test for sample adequacy and the Bartlett globality test were performed. Cronbach's Alpha internal consistency index was investigated in the whole of the scale and sub-dimensions as part of the reliability study.

### Findings

In this section, validity and reliability studies carried out in line with the development stages of the School Principals' Coaching Proficiency Scale. In order to determine the validity of the data obtained with the implementation of Coaching Proficiency Scale, first exploratory, then confirmatory, factor analyses were carried out. Fundamental component analysis was used as the extraction method and the varimax method was chosen to determine the factor pattern. The Variance explanation rate of 0.50 and above were taken as the base of the scale. Four factors of eigenvalue 0.1 and above were obtained for the 36 indices taken as the basis for the analysis as a result of the factor analysis. The results of the exploratory factor analysis results are in Table 7.

Table 7

*Coaching Proficiency Scale Exploratory Factor Analysis Results*

<b>Indices</b>	<b>Load Value After Conversion</b>
----------------	------------------------------------

## A Study on the Motives behind Vocational School Students' Preference

	Factor 1	Factor 2	Factor 3	Factor 4
Displays flexible behavior in incidents and situations.	0.72			
Contributes to the creation of an open environment for debates on educational issues and constructive criticism with teachers.	0.71			
Uses open, plain, non-judgmental and positive language.	0.69			
Listens to, summarizes and reflects what teachers say during meetings.	0.67			
Listens to teachers with full attention.	0.64			
Encourages teachers to express their emotions, thoughts and recommendations.	0.63			
Does not prioritize him/herself in relationships with teachers.	0.62			
Displays effort to create a stress-free environment.	0.61			
Takes action for teachers to participate in professional activities suitable for the school's educational targets.	0.56			
Is attentive in following the process, reporting, evaluating and feedback.	0.55			
Makes teachers feel when there are internal organization problems or conflicts that he/she tries to see them through the teachers' perspective as much through his/her own.	0.55			
Follows a management strategy which balances teachers' characters and personal characteristics.	0.54			
Mediates to find solutions that completely meet the expectations of all sides when conflict arises between teachers.	0.54			
Guides teachers in the creation of options aimed at the multifaceted evaluation and development of teachers.	0.53			
Observes lessons and gives teachers feedback.		0.80		
Plays a facilitative role for teachers to define their education goals with in-class observations.		0.66		
Holds up a mirror to teachers so that they can discover ideas, feelings and beliefs which ensure they take action in line with the goals they have specified.		0.66		
Evaluates whether in-class activities are suitable for the educational targets or not and paves the way for teachers to reformulate their educational strategies.		0.63		
Shows teachers how to develop methods for learning via cooperation, inquiry, questioning or discovery.		0.56		
Asks questions that ensure teachers notice learning outcomes through experience in the situation they are in.		0.56		
Guides in pedagogical matters such as strategies for gaining students' attention, classroom management and asking questions.		0.54		

Table 7 (Continued)

Indices	Load Value After Conversion			
	Factor 1	Factor 2	Factor 3	Factor 4

---

Possesses an innovative understanding that tries to create alternative solutions.	0.66
Ensures data related to the results of work carried out in the school is gathered and that activities that could contribute to the development of the school are investigated.	0.62
Establishes a balance between formal and informal communication in internal organization communication.	0.59
Does not refrain from expressing failure in a negative situation in as much as they praise success.	0.59
Hold up a light so that the advantages and disadvantages of solutions developed are analyzed correctly for teachers to solve problems.	0.56
Supports the formation of a culture of continual development.	0.54
Is open to continual learning and development.	0.53
Informs teachers of innovations in educational programs and awakens interest in how to effectively implement them.	0.51
Provides support for the discussion of problems teachers identify in the organization and classroom.	0.70
Shows he/she trusts the teachers.	0.69
Encourages teachers to develop awareness in noticing internal organization and in-class problems.	0.59
Tracks teachers and students to determine whether targets are reached or not.	0.58
Is reliable in all decisions, practices and evaluations.	0.54
Possesses an inner harmony in relationships with teachers which is calm, balanced, self-confident and does not take criticism personally.	0.54
Guides teachers to choose the most appropriate solution from amongst many alternatives.	0.53

Explained Variance: 59.15

Factor 1: 20.59

Factor 2: 14.05

Factor 3: 12.50

Factor 4: 12.00

---

The factors formed from the results of the exploratory factor analysis have been named as follows:

1. Factor 1: Social Proficiencies
2. Factor 2: Educational Sciences Proficiencies
3. Factor 3: Research and Development (R&D) Proficiencies
4. Factor 4: Problem Solving Proficiencies

The contribution of "Social Proficiencies" factor to the total variance has been determined to be 20.59 percent, 14.07 for the "Educational Sciences Proficiencies" factor, 12.50 percent for the "R&D Proficiencies" factor and 12.00 percent for the "Problem-solving proficiencies" factor with a total factor contribution to the total variance being 59.15 percent. The "Social Proficiency Factor" is made up of fourteen indices, the "Educational Sciences Proficiencies" of seven indices, the "R&D Proficiencies" of eight indices and the "Problem-solving Proficiencies" of seven indices.

The Cronbach's Alpha reliability factors obtained from the fundamental and sub-dimensions at the end of the scale's reliability analysis are found in Table 8. The reliability factors of the entire scale and the

## A Study on the Motives behind Vocational School Students' Preference

sub-dimensions is above 0.70. These values show that the reliability of both the sub-dimensions and the entire scale is of a high level (Kalayci, 2010).

Table 8

*Reliability Factors Related to School Principals' Coaching Proficiencies*

<b>Dimension</b>	<b>Cronbach's Alpha reliability factors</b>	<b>Index Count</b>
Social Proficiencies	0.88	14
Educational Sciences Proficiencies	0.87	7
R&D Proficiencies	0.86	8
Problem Solving Proficiencies	0.87	7
GENERAL	0.89	36

The factor structure determined by exploratory factor analysis was tested with the confirmatory factor analysis using the AMOS 21 packet program. In order to reveal the compliance of the model's data set in the confirmatory factor analysis of the scale,  $\chi^2/df$ , GFI, CFI, RMSEA, and AGFI values were considered. The compliance indeces,  $\chi^2/df$ , GFI, CFI, RMSEA, and AGFI values as well as the acceptable compatibility of these compliance indeces and reference values for situations of good compliance are shown in Table 9.

Table 9

*Confirmatory Factor Analysis Compatibility Indices of the School Principals' Coaching Proficiencies Scale*

	$\chi^2/df$	CFI	RMSEA	GFI	AGFI
<b>Recommended Model</b>	1551.94 / 590=2.630	0.92	0.05	0.86	0.85
<b>Acceptable Compliance Values</b>	$\leq 5$	$\geq 0.90$	0.06-0.08	0.85-0.89	0.85-0.89
<b>Good Compliance Values</b>	$\leq 3$	$\geq 0.97$	$\leq 0.05$	$\geq 0.90$	$\geq 0.90$

When the results of the confirmatory factor analysis of the School Principals' Coaching Proficiencies Scale is examined,  $\chi^2/df$  values have a well compliance value. As the CFI, GFI, AGFI and RMSEA values are of an acceptable separation, this shows that the confirmatory factor analysis results are compliant with the recommended factor structure's data set. The confirmatory factor analysis diagram of the "School Principals' Coaching Proficiencies Scale" are found in Figure 2.

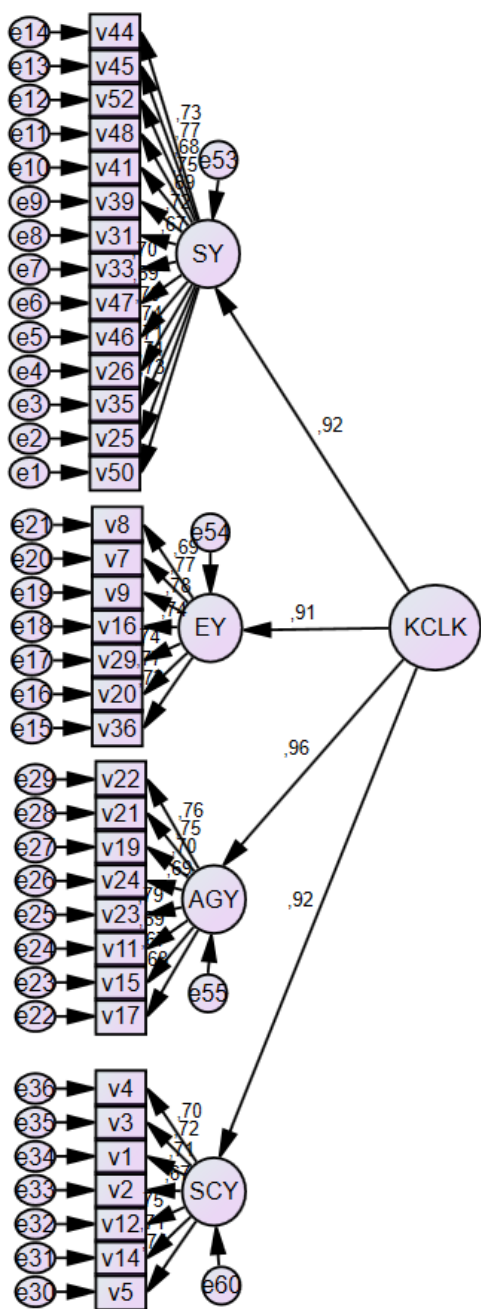


Figure 2. Confirmatory Factor Analysis Diagram of the School Principals' Coaching Proficiencies Scale

**Discussions, Results and Recommendations**

In this study, we aimed to develop the “School Principals’ Coaching Proficiencies Scale” in order to determine the proficiencies of school principals’ coaching based on the views of teachers. Various statistical analyses were conducted for scale’s validity and reliability study. In order to ensure the validity of the scope, a hypothetical framework was created by reading the literature of the field and, after the necessary corrections were made, a pilot program was conducted with the 201 teachers who were not included in the sample group. Validity and reliability analyses were performed on the data obtained from the pilot program, were put into practice to gather the data to be used to obtain findings by making the necessary corrections and adjustments in light of the analysis results and views and recommendations of the teachers participating in the pilot program. After the data collection stage, exploratory factor and confirmatory factor analyses were conducted in order to investigate structure validity.

The Kaiser Meyer-Olkin (KMO) test for sample adequacy and the Bartlett globality test were conducted. The Bartlett test ( $p= 0.00$ ) was found to be meaningful and the KMO test was found to be 0.94, over its acceptable value of 0.50. These values show that the data set is of an excellent suitability in order to perform factor analysis of the data set (Cokluk; Sekercioglu and Buyukozturk, 2016; Kalayci, 2010; Karagoz, 2016, ref Sharma, 1996). Four factors with an eigenvalue of 0.1 and above were obtained for the 36 indices taken as the foundation of the analysis as a result of the factor analysis and these factors were named as “social proficiencies”, “educational sciences proficiencies”, “R&D proficiencies” and “problem solving proficiencies”. The contribution made by the “social proficiencies” factor was 20.59 percent, 14.07 percent by the “educational sciences proficiencies” factor, 12.50 percent by the “R&D proficiencies” factor and 12.00 percent by the problem-solving factor with the total contribution made by the four factors being found to be 59.15 percent. The “social proficiencies factor” comprises of fourteen indices, the “educational sciences proficiencies” seven, “R&D proficiencies” eight and the “problem solving factor” seven. When the results of the confirmatory factor analysis are investigated, the  $\chi^2/df$  value was observed to be of good compliance with the GFI, AGFI and RMSEA values being of an acceptable separation. The results of the confirmatory factor analysis show that the recommended factor structure is compliant with the data set.

At the conclusion of the scale's reliability analysis, the Cronbach's Alpha reliability factors of the fundamental and sub-dimensions was found to be above 0.70. It has been observed that the reliability of both the sub-dimensions and the whole of the scale is of a high degree. (Kalayci, 2010).

A scale of 36 indices that can be used to determine the coaching proficiencies of school principals based on the views of teachers was developed. The findings obtained from the conducted validity and reliability studies have shown that the scale is a valid and reliable scale tool that can be used to quantify the coaching proficiencies of school principals based on the views of teachers.

The validity and reliability studies related to the scale and can be repeated with different sample groups. The scale can determine the perceptions related to the coaching skills of school principals by adapting the scale for school principals.

## References

- Anderson, V. (2013). A trojan horse? the implications of managerial coaching for leadership theory. *Human Resource Development International*. 16 (3), 251-266. DOI: 10.1080/13678868.2013.771868.
- Ai, X. & Rivera, N. (2003). *Program Evaluation and Research Branch Los Angeles Unified School District*. Paper presented at the annual meeting of the American Educational Research Association, Chicago, USA. [http://notebook.lausd.net/pls/ptl/docs/PAGE/CA\\_LAUSD/FLDR\\_ORGANIZATIONS/FLDR\\_PLCY\\_RES\\_EV/PAR\\_DIVISION\\_MAIN/RESEARCH\\_UNIT/PUBLICATIONS/CONFERENCE\\_PRESENTATIONS/COACHING%20AERA%202003.PDF](http://notebook.lausd.net/pls/ptl/docs/PAGE/CA_LAUSD/FLDR_ORGANIZATIONS/FLDR_PLCY_RES_EV/PAR_DIVISION_MAIN/RESEARCH_UNIT/PUBLICATIONS/CONFERENCE_PRESENTATIONS/COACHING%20AERA%202003.PDF).
- Balci, A. (2010). *Sosyal bilimlerde arastirma yontem, teknik ve ilkeler*. Pegem Akademi, Ankara.
- Baltas, Z. (2011). *Kurum ici kocluk: is tatmini yaratmak, verimliliği artirmak*. Remzi Kitabevi, Istanbul.
- Canakkale National Education Directorate, Web site: <https://canakkale.meb.gov.tr/>
- Cokluk, O., Sekercioglu, G. ve Buyukozturk, S. (2016). *Sosyal bilimler icin cok degiskenli istatistik spss ve lisrel uygulamalari*, Pegem Akademi, Ankara.
- DPT (Turkiye Cumhuriyeti Basbakanlik Devlet Planlama Teskilati). (2004). *Ilcelerin sosyo-ekonomik gelismislik siralamasi arastirmasi (2004)*. <http://www.kalkinma.gov.tr/Lists/Yaynlar/Attachments/299/ilce.pdf>.
- Duncan, H. E. & Stock, M. J. (2010). Mentoring and coaching rural school leaders: what do they need? *Mentoring & Tutoring: Partnership in Learning*, 18 (3). 293-311. DOI: 10.1080/13611267.2010.492947.
- Ellinger, A. D. & Bostrom, R. P. (1999). Managerial coaching behaviors in learning organizations. *Journal of Management Development*, 18 (9), 752-771. DOI: 10.1108/02621719910300810.
- Ellinger A. D., Ellinger, A. E. & Keller, S. B. (2003). Supervisory coaching behavior, employee satisfaction, and warehouse employee performance: a dyadic perspective in the distribution

- Industry. *Human Resource Development Quarterly*, 14 (4), 435-458. DOI: 10.1002/hrdq.1078.
- Ellinger, A. D., Ellinger, A. E., Bachrach, D. G., Wang, Y., & Bas, A. B., (2010). Organizational investments in social capital, managerial coaching, and employee work-related performance. *Management Learning*, 42 (1), 67-85. DOI: 10.1177/1350507610384329.
- Evered, R.D. & Selman, J.C. (1989). Coaching and the art of management. *Organizational Dynamic*, 18 (2), 16-32. DOI: 10.1016/0090-2616(89)90040-5.
- ICF (International Coach Federation). (2017a). *Kocluk nedir?*. <http://www.icfturkey.org/neden-kocluk/kocluk-nedir/>
- Kalayci, S. (2010). *SPSS uygulamali cok degiskenli istatistik teknikleri*, Asil Yayin, Ankara.
- Karagoz, Y. (2016). *SPPS 23 ve AMOS 23 uygulamali istatistiksel analizler*, Nobel Yayin Dagitim, Ankara.
- Krasnoff, B. (2015). *Leadership coaching: evidence-based best practices*. Northwest Corpherensive Center at Education Northwest Web site: <http://nwcc.educationnorthwest.org/sites/default/files/practice-brief-leadership-coaching.pdf>.
- Laba, K. (2011). *Coaching for school improvement: a guide for coaches and their supervisors*. Center on Innovation & Improvement, Lincoln, USA. [http://www.adi.org/about/downloads/coaching\\_for\\_school\\_improvement.pdf](http://www.adi.org/about/downloads/coaching_for_school_improvement.pdf).
- McLean, G. N., Yang, B., Kuo, C., Tolbert, A. & Larkin, C. (2005). Development and initial validation of an instrument measuring managerial coaching skill. *Human Resource Development Quarterly*, 16 (2), 157-178. DOI:10.1002/hrdq.1131.
- Mangin, M. M. (2007). Facilitating elementary principals' support for instructional teacher leadership. *Educational Administration Quarterly*, 43 (3), 319-357. DOI: 10.1177/0013161X07299438.
- NASSP&NAESP (National Association of Secondary School Principals and National Association of Elementary School Principals). (2013). *Leadership matters: what the research says about the importance of principal leadership* <http://www.naesp.org/sites/default/files/LeadershipMatters.pdf>.
- Niddus, G. & Sadler, M. (2011). The principal as formative coach. *Coaching: The New Leadership Skill*, 69 (2), 30-35. [https://www.mbaea.org/documents/resources/principal\\_as\\_formative\\_coach\\_3542EA0A1AEE7.pdf](https://www.mbaea.org/documents/resources/principal_as_formative_coach_3542EA0A1AEE7.pdf).
- Orth, C.D., Wilkinson, H. E. & Benfari, R. C. (1987). The manager's role as coach and mentor. *Organizational Dynamics*, 15 (4), 66-74. DOI: 1016/0090-2616(87)90045-3.
- Redshaw, B. (2000). Do we really understand coaching? how can we make it work better? *Industrial and Commercial Training*, 32 (3), 106-109. DOI: 10.1108/00197850010371693.
- Ronald, W. (2012). *Coaching teachers: an important principal role*. Education Partnerships Inc. <http://files.eric.ed.gov/fulltext/ED538322.pdf>.
- Trail, K. (2000). Taking the lead: the role of the principal in school reform. *CSRD Connections*, 1 (4). 1-5. <http://files.eric.ed.gov/fulltext/ED451604.pdf>
- Wise, D. & Jacobo, A. (2010). Towards a Framework for Leadership Coaching. *School Leadership & Management*, 30 (2). 159-169. DOI:10.1080/13632431003663206.
- Yirci, R., Ozdemir, T.Y, Kartal, S.E. ve Kocabas, I. (2014). Teachers' perceptions regarding school principals' coaching skills. *School Leadership & Management: Formerly School Organisation*, 34 (5), 454-469. DOI: 10.1080/13632434.2014.905465.

# Early Academic and Language Skills of Children from Urban and Rural Areas

Ozgun Uyanik Aktulun

## I. Introduction

The language, which has a central role in the mental development of the individual and is one of the most prominent features of development, is acquired by everyday life experiences without any special method or method being taught by all children who normally develop from birth. With stimuli taken from the social environment, children develop verbal language skills such as listening, understanding, logical thinking, proper reaction, speaking, conversation in spoken language, enrichment of vocabulary, understanding of the meaning of words, use in more complex sentence structures and language meaning (Snow, Burns and Griffin, 1998; Ezell and Justice, 2005). Language skills consist of the skills of "listening, speaking, reading and writing" under the skills of understanding and speaking, and are gained according to the stated order. Depending on the language development, children are beginning to use the language skills professionally in the pre-school period (Berk, 2013) and use their vocabulary correctly by pronouncing the correct words and pronouncing correctly (Beauchat et al., 2010: 16-17; Morrow, 2007: 76-77).

The language that develops and enriches over time in the pre-school period also positively reflects on the development of the child's academic skills such as reading and writing, mathematics (Browne, 2007, p. 2; Riley, 2006; Powell and Diamond, 2012) and social skills (Bonica et al., 2003). The acquisition of riches, pronunciations and language skills of children's vocabulary knowledge also helps them acquire phonological awareness, alphabet knowledge and literacy skills that are the first steps of children's literacy skills (Whitehurst and Lonigan, 2001; Beauchat et al., 2010: 94; Riley, 2006: 66; Strickland and Riley-Ayers, 2007: 36). In mathematics, which is another area of early academic skills, children can acquire sub-skills such as mathematical concepts, recognition, naming, matching, comparison, grouping, sorting, numbers, operations, modeling, geometry, spatial logic, measurement and forming graphics (Charlesworth and Lind, 2007; Eliason and Jenkins, 2003; Ezell and Justice, 2005; Jackman, 2012).

In order to understand and develop the language, literacy and mathematics found in every area of life and in every circumstance, children need to create a circle of natural curiosity and discovery skills, play-based activities and a social environment provided by child-adult, child-child interaction (Jackman, 2012). According to Bronfenbrenner's Ecological System Theory, the child develops in an affected complex system that surrounds the growing place. The individual characteristics of the child's biological biology are influenced by the environmental factors combined with their development. The ecological system can consist of inner and outer layers such as the school where the child is educated, especially the parents and siblings that make up the house and family in which the child lives, the neighborhood where the school and the house are located, education system, political system and economic system. It can be said that each layer is related to each other. The development of the child can change according to the direction of the interactions in the social environment (Bee and Boyd, 2009; Berk, 2013). Vygotsky emphasizes the zone of proximal development and points out the importance of the activities of the child with the cultures, language, mental tools, teachers, peers or parents, especially on the cognitive and language development and other related development and skill areas (Bodrova and Leong, 2013).

One of the most crucial factors supporting these theories is the developmental differences of children born and raised in different environmental conditions. The fact that children are born and the place where they live is a city or a village, which leads to differences in accessibility to resources, economic characteristics, characteristics of human communities, social environment and cultural activities, and can have significant effects on children's development and experience. For example, in Turkey, there are significant differences in population between city and village. Villages with limited



population generally have limited access to important resources such as hospitals, schools, libraries, museums and well-paid jobs (Evans, 2006; Vernon-Feagans, Gallagher and Kainz, 2010). For this reason, children living in the village may have little experience and awareness of these areas. At the same time, it is difficult for children living in villages to reach stimulating areas to support their cognitive development due to economic inadequacies, geographical conditions and transportation barriers (Vernon-Feagans, Gallagher and Kainz, 2010). For children living in the urban environment, the quality of early learning environments for children can be improved because it is easier to reach rich educational and cultural environments (Miller and Votruba-Drzal, 2013). Home literacy environment and beliefs about children's literacy and materials at home, parenting styles and early academic skills influence their development (Glick, Bates and Yabiku, 2009). It has been shown that parents who live in rural areas are less emotionally supportive, more intrusive and stricter towards their children (Bornstein et al., 2008), have less expectations of children's achievement (Lampard, Voigt, & Bornstein, 2000) and participate less in parent involvement activities while they make less investment in cultural experiences (Roscigno, Tomaskovic-Devey, and Crowley, 2006). At the same time, children living in the city have a longer chance of attending pre-school education than children living in the village (Grace et al., 2006). Despite the fact that research has shown that parents living in the city are more beneficial in supporting the development of children, traffic, environmental pollution, and poor access to nature are among the negative factors affecting the development of children in the urban environment (Linares et al., 2001, Wachs and Camli, 1991).

At the same time, environmental factors include parenting behaviors, socio-economic status, and basic systems that affect the child's development in terms of parental education and occupation (Berk, 2013). The family can show less supportive parenting behaviors as the crime rate, economic level, the quality of the schools they attend, the security and transportation facilities worsen in the social system of the child (Baydar, Kuntay, Goksen, Yagmurlu and Cemalcilar, 2010). Language development and reading success can be adversely affected by adverse conditions and children with limited opportunities (Cabell, Justice, Konold, McGinty, 2011; Cabell, Justice, Logan, Konold, 2013), leaving behind their peers in literacy skills such as phonological awareness, letter naming, word writing and word recognition (Aram and Levin, 2001, 2004; Clements, Reynolds and Hickey, 2004). In addition, there may be a significant difference between the children from low and middle socioeconomic level families and those from high socioeconomic level families, and this difference may expand in the process of schooling (Denton and West, 2002; Geary, 2006). In the relevant literature, it has been found that children from low perform lower than the ones from high socioeconomic status in their academic achievement tests (Duncan et al., 1994; Bradley and Corwyn, 2002). This performance difference seen in pre-school children is a sign that academic achievement at further education levels may also be low (Duncan et al., 2007, Jordan, Kaplan, Ramineni and Locuniak, 2009).

Although there are significant differences in educational, social, cultural and medical services between urban and rural areas, a limited number of studies examining differences between urban and rural children's development suggest that living in the city may be related to the development of early academic skills (Lee and Burkham, 2002). However, Grace et al. (2006) found that rural children did not exceed 10 percent of their ability to recognize sound and letters in their research that compared children's early literacy skills in rural life and urban life. Lee and Burkham (2002) found that children living in rural areas and medium-sized cities scored roughly .05-.15 SD behind children living in suburbs and large cities in measures of reading and math skills controlling for sociodemographic characteristics.

A limited number of studies are available for the purpose of reviewing and comparing the language, literacy and math skills of children living in urban and rural areas. However, there is not a study addressing particularly early academic and language skills of preschool children living in rural and urban areas in Turkey. It is also thought that the comparison of children living in urban and rural areas in terms of early academic and language skills will contribute methodologically to the current research on urbanization and the field of language, literacy and mathematics. In this context, in order to investigate the difference between the early academic and language skills of pre-school children living in urban and rural areas, the main hypothesis for this study is as follows:

"There is a statistically significant difference between the early academic and language skills scores of 60-72-month-old preschoolers from urban and rural areas."

## 2. Method

### 2.1 Research Model

This study, aiming to determine whether there is a difference between the early academic and language skills of 60-72-month-old children living in rural and urban areas and attending to pre-school education, follows the principles of general survey model.

### 2.2 Population and Sampling

The population of the study was comprised of 60-72-month-old children who were attending to nursery classes of elementary schools located in Afyonkarahisar - Turkey city center and surrounding villages during 2016-2017 academic year. The survey included 210 children aged 60-72 months and showing normal developmental characteristics who attended nursery classes of randomly selected 15 elementary schools located in villages and same number of children, with same characteristics from randomly selected 12 elementary schools located in the city center.

Of the village children included in the sampling, 51.0% were girls, 49.0% were boys, 5.2% were single children, 36.2% had one sibling, 42.4% had two siblings, 16.2% of them had three or more siblings, 4.3% of their mothers were illiterate, 11% were primary school, 73.8% were middle school, 9% were high school and 1.9% were university graduates, 5.7% of their fathers were primary school, 59.5% are middle school, 31.4% were high school and 3.3% were university graduates, 94.3% of their mothers did not work and 5.7% were workers, 4.8% of the fathers were civil servants, 47.1% were workers and 48.1% were self-employed.

Of the urban children included in the sampling, 46.7% were girls, 53.3% were boys, 27.1% were single children, 51.4% had one sibling, 18.6% had two siblings, 2.9% of them had three or more siblings, of their mothers 21% were middle school, 38% were high school and 41% were university graduates, 8.1% of their fathers were middle school, 39.5% were high school and 52.4% were university graduates, 34.3% of their mothers did not work and 45.7% were civil servants, 4.8% were workers, of the fathers 43.8% were civil servants, 7.6% were workers and 48.6% were self-employed.

### 2.3 Data Collection Tools

The "Personal Information Form" was used to collect the personal information of the children (gender, number of siblings, education status of the parents, occupations). At the same time, the "Kaufman Survey of Early Academic and Language Skills" was used as a data collection tool to assess early academic and language skills of children.

*Personal Information Form:* In this study, a personal information form developed by the researcher to collect personal information about children, including questions about birth date, gender, number of siblings, parents' education level and occupation was used. Personal information forms have been filled out by the researcher for each child depending on the information in the personal development files of the children in the school.

*Kaufman Survey of Early Academic and Language Skills - K-SEALS:* Kaufman Survey of Early Academic and Language Skills original form was developed by Kaufman and Kaufman (1993) and provides assessment of early language, cognitive competence and academic skills of children aged 36-83 months. K-SEALS consists of three sub-tests, four sub-tests, and an Early Academic & Language Skills Composite, which include the children's early academic and language skills, Word Knowledge, Numbers, Letters & Words and Articulation Survey. It is applied in a quiet and comfortable environment. When the test is applied, each item illustration in the easel is shown to the children, the instruction of the item is read aloud and expected to be answered by the children. For each correct answer, one (1) score is recorded in the test registration form and zero (0) point for each incorrect answer. The test consists of a total of 90 items and it takes 15-25 minutes for each child to apply. The raw score for each subtest is the number of items correctly answered (Kaufman and Kaufman, 1993). In

Turkey Uyanik and Kandir (2014) adapted K-SEALS according to the Turkish children and confirmatory factor analysis according to the total it was determined the one-dimensional factor structure was verified. The KR-20 reliability coefficient for K-SEALS was found to be .971 and the item total correlation coefficient of the majority of the items was at a high level of reliability. The test retest correlation for K-SEALS total was set at .908. The relationship between the two test results was found to be significant at  $p < 0.01$  level.

#### 2.4. Data Analysis

The Kolmogorov-Smirnov (K-S) normality test was used to analyze whether children's scores on the Kaufman Survey of Early Academic and Language Skills were normally distributed. Then, t-test was used to investigate the differences between groups. Significance level was set at .01 and it was stated that there was no significant difference in case of  $p > .05$ .

### 3. Findings

**Table 1.** T-test Results Regarding Early Academic and Language Skills of 60-72-month-old Children Living in Urban and Rural Areas

Sub-scales	Groups	n	$\bar{x}$	ss	sd	t	p
<b>Vocabulary</b>	Rural	210	20.52	4.42	418	-8.82	<b>0.000</b>
	Urban	210	24.14	3.94			
<b>Numbers, Letters &amp; Words</b>	Rural	210	8.96	3.05	418	-9.80	<b>0.000</b>
	Urban	210	13.49	5.96			
<b>Articulation Survey</b>	Rural	210	13.54	4.07	418	-3.36	<b>0.001</b>
	Urban	210	14.87	4.00			
<b>Receptive Language Skills</b>	Rural	210	18.25	3.68	418	-9.00	<b>0.000</b>
	Urban	210	21.91	4.59			
<b>Expressive Language Skills</b>	Rural	210	11.23	2.99	418	-12.11	<b>0.000</b>
	Urban	210	15.72	4.45			
<b>Early Academic Language Skills Composite</b>	Rural	210	43.03	7.78	418	-10.49	<b>0.000</b>
	Urban	210	52.50	10.51			

$p < .01$

According to Table 1, there was a significant difference between vocabulary, numbers, letters & words, articulation survey subtest scores, receptive language and expressive language skills sub-scale scores and the composite scores of 60-72-month-old preschoolers living in urban and rural areas. It was determined that the children who lived in the city got higher scores than the children living in the village in all the subtests, scales and the composite and this difference was statistically significant. This result is quite remarkable.

#### 4. Discussion

Language and academic skills develop from early on, affected by environmental factors, and cause differences in children's skill levels. This, in turn, makes it necessary to investigate early academic and language skills of children from the pre-school period.

Geographical isolation in rural areas, economic inadequacies, and less attendance to institution-centered pre-school education can lead to lower literacy and mathematical skills in children and lower success rates in advanced academic skills (Vernon-Feagans et al., 2010). At the same time, reasons such as parenting practices in urban and rural settings, and the level of knowledge about child development and education can lead to differences in children's early academic and language skills (Bornstein et al., 2008). Parents living in the city were reported to have higher child-rearing attitudes (Lampard et al., 2000).

Miller and Votruba-Drzal (2013) carried out a research on 6050 children living in urban and rural areas in terms of their 9-month, 2-year, 4-year, and 5-year-old longitudinal early academic skills and

childhood experiences. They found out that children in large urban and rural areas started in kindergarten with less developed reading and math skills than children in small urban areas and rural areas. Rural children starting in kindergarten with lower early academic skills are partly included in home-based pre-school education, which is less institution-based pre-school education before they start to kindergarten, having a less advantageous home environment, less exposure to cognitive stimulants and activities have had a less positive parenting role, and have been associated with their parents' socio-demographic characteristics. With little or no difference, children living in big cities have lower early academic skills than peers who live in small cities, which is due to their parents having less knowledge about child development. The research found that parents of children living in rural areas had lower socio-demographic characteristics, fewer materials for reading and writing in the home environment, and less child care arrangements. On the other hand, Grace et al. (2006) point out that children living in rural areas have advantages such as having more suitable and fewer children in the kindergarten, having a regular class, having regular family meals and having a safe living environment. However, when children living in rural areas compared to children living in urban areas, they stated that there were many developmental disadvantages at the beginning of kindergarten. The differences in children, both in the family environment and in early care and education centers, are the economic and demographic factors that cause developmental differences between children. The study found that the educational level of the parents of children in rural areas was at least one lower than the education level of the parents of the children in the non-rural areas and the economic income of the parents of the children living in non-rural areas was higher. It was also found that middle and high-income groups living in rural areas have a higher likelihood of participating in work at home often (such as making art projects, reading or playing games), compared to non-rural families in the same income. Lee and Burkam (2002) found that children from disadvantaged communities started in kindergarten with lower cognitive abilities than children from more advantageous regions, which linked this to unequal living conditions. Children from disadvantaged communities can systematically attend low-quality primary schools. The gap between the two groups is increasing because the quality of the school, inadequate educational resources, teacher qualifications and attitudes affect the success of children. Denton and West (2002) found that children from low-income and middle-income backgrounds had a large gap between reading and mathematical knowledge, and this was increasingly widespread throughout the schooling process. It is seen that the results obtained from the researches related to early academic and language skills of children living in urban and rural areas in the literature have been supporting the findings of this study.

## 5. Conclusions and Suggestions

According to the results obtained from the study, there is a significant difference between the 60-72-month-old children living in urban and rural areas in terms of the Kaufman Survey of Early Academic and Language Skills scales and the composite scores. Mean ranks of the children living in urban areas in terms of Kaufman Survey of Early Academic and Language Skills sub-scales, scales and the composite were found out to be higher than those of children living in rural areas.

This result clearly demonstrates the impact of the environment where children are raised on their early academic and language skills.

The primary purpose of early childhood education is to eliminate the disparity of opportunity for children. In particular, children living in rural areas may be encouraged to use institutionalized educational facilities as early as possible in their initial years of life or different educational models such as mobile kindergartens or may be used.

Trainings, conferences, brochures, booklets, CDs can be distributed to parents of children living in rural areas to popularize and promote education.

The importance given to parent education programs in rural schools can be enhanced. Teachers and principals can guide parents to activities and techniques that will support the development of their children at home settings. Again, within this scope, it is possible to use media to reach the families.

In rural schools, courses including practices for the development of academic and language skills for both parents and their children can be organized.

Since early academic and language skills of children living in rural areas are not adequately supported, more comprehensive educational programs can be planned and implemented to support these children's early skills. In-service training seminars can be organized systematically for the content of the training program to be organized and for the implementation of this program so that pre-school teachers can support early academic and language skills.

## 6. References

- Aram, D., & Levin, I. (2001). Mother-child joint writing in low SES: Sociocultural factors, maternal mediation, and emergent literacy. *Cognitive Development, 16*(3), 831-852. [doi.org/10.1016/S0885-2014\(01\)00067-3](https://doi.org/10.1016/S0885-2014(01)00067-3).
- Aram, D., & Levin, I. (2004). The role of maternal mediation of writing to kindergartners in promoting literacy achievements in school: A longitudinal perspective. *Reading & Writing: An Interdisciplinary Journal, 17*(4), 387-409. doi: 10.1023/B:READ.0000032665.14437.e0.
- Baydar, N., Kuntay, A., Goksen, F., Yagmurlu, B. & Cemalcilar, Z. (2010). *Turkiye'de erken cocukluk gelism ekolojileri arastirmasi [Early childhood ecologies in Turkey]* (Proje No. 106K347). Istanbul: Koc Universitesi. Retrieved at January 12, 2018, from <http://www.manevisosyalhizmet.com/wpcontent/uploads/2014/01/erkencocuklukgelisimekolojileriarastirmasi.pdf>.
- Beauchat, K. A., Blamey, K. L., & Walpole, S. (2010). *The building blocks of preschool success*. USA: The Guilford Press.
- Bee, H., & Boyd, D. (2009). *Cocuk gelism psikolojisi [Child development]*. Istanbul: Kaknus Press.
- Berk, L. E. (2013). *Cocuk gelisimi [Child development]*. Istanbul: Imge Press.
- Bodrova, E., & Leong, D. J. (2013). *Zihnin araclari: Erken cocukluk egitiminde Vygotsky yaklasimi [Tools of the mind: Vygotskian approach to early childhood education]* (Trans. Ed. G. Haktanir). Ankara: Ani Publishing.
- Bonica, C., Arnold, D.H., Fisher, P.H., Zeljo, A., & Yerushova, K. (2003). Relational aggression, relational victimization, and language development in preschoolers. *Social Development, 12*(4), 551-562. doi: 10.1111/1467-9507.00248
- Bornstein, M. H., Putnick, D. L., Heslington, M., Gini, M., Suwalsky, J., Venuti, P., et al. (2008). Mother-child emotional availability in ecological perspective: Three countries, two regions, two genders. *Developmental Psychology, 44*, 666-680. doi: 10.1037/0012-1649.44.3.666.
- Bradley, R.H. & Corwyn, R.F. (2002). Socioeconomic status and child development. *Annual Review of Psychology, 53*, 371-399. doi: 10.1146/annurev.psych.53.100901.135233
- Browne, A. (2007). *Teaching and learning, communication, language and literacy*. Great Britain: Paul Chapman Publishing.
- Cabell, S.Q., Justice, L.M., Konold, T.R. & McGinty, A.S. (2011). Profiles of emergent literacy skills among preschool children who are at risk for academic difficulties. *Early Childhood Research Quarterly, 26*(1), 1-14. [doi.org/10.1016/j.ecresq.2010.05.003](https://doi.org/10.1016/j.ecresq.2010.05.003)
- Cabell, S. Q., Justice, L. M., Logan, J. A. R., Konold, T. R. (2013). Emergent literacy profiles among prekindergarten children from low-SES backgrounds: Longitudinal considerations. *Early Childhood Research Quarterly, 28*, 608-620. doi.org/10.1016/j.ecresq.2013.03.007
- Charlesworth, R., & Lind K. K. (2007). *Math & science for young children* (Fifth edition). USA: Thomson Delmar Learning.
- Clements, M. A., Reynolds, A. J., & Hickey, E. (2004). Site-level predictors of children's school and social competence in the Chicago Child-Parent Centers. *Early Childhood Research Quarterly, 19*(2), 273-296. [doi.org/10.1016/j.ecresq.2004.04.005](https://doi.org/10.1016/j.ecresq.2004.04.005)
- Denton, K., & West, J. (2002). *Children's reading and mathematics achievement in kindergarten and first grade* (NCES 2002-125). Retrieved at 14 June, 2018, from <https://files.eric.ed.gov/fulltext/ED461438.pdf>.
- Duncan, G. J., Dowsett, C. J., Claessens, A., Magnuson, K., Huston, A. C., Klebanov, P., Pagani, L.S., Feinstein, L. Engel, M., Brooks-Gunn, J., Sexton, H. Duckworth, K. & Japel, C. (2007). School

- readiness and later achievement. *Developmental Psychology*, 43, 1428–1446. doi:10.1037/0012-1649.43.6.1428
- Duncan, G.J., Brooks-Gunn, J., & Klebanov, P.K. (1994). Economic deprivation and early childhood development. *Child Development*, 65(2), 296–318. doi: 10.1111/j.1467 8624.1994.tb00752.x
- Eliason, C., & Jenkins, L. (2003). *A practical guide to early childhood curriculum*. Ohio: Merrill Prentice Hall.
- Evans, G. W. (2006). Child development and the physical environment. *Annual Review of Psychology*, 57, 423–451. doi:10.1146/annurev.psych.57.102904.190057
- Ezell, H. K., & Justice, L. M. (2005). *Shared story book building young children's language and emergent literacy skill*. Maryland: Paul H. Publishing Co. Inc.
- Geary, D. C. (2006). Development of mathematical understanding. In W. Damon & R.M. Lerner (Series Eds.) & D. Kuhn & R. S. Siegler (Vol. Eds.), *Handbook of child psychology: Volume 2: Cognition, perception, and language* (6th ed., pp. 777–810). Hoboken, NJ: Wiley.
- Glick, J. E., Bates, L., & Yabiku, S. T. (2009). Mother's age at arrival in the United States and early cognitive development. *Early Childhood Research Quarterly*, 24, 376–380. doi.org/10.1016/j.ecresq.2009.01.001
- Grace, C., Shores, E. F., Zaslow, M., Brown, B., Aufseeser, D., & Bell, L. (2006). *Rural disparities in baseline data of the Early Childhood Longitudinal Study: chartbook*. Mississippi State, MS: National Center for Rural Early Childhood Learning Initiatives.
- Jackman, H .L. (2012). *Early education curriculum a child's connection to the world* (Fifth edition). USA: Wadsworth, Cengage Learning.
- Jordan, N. C., Kaplan, D., Ramineni, C., & Locuniak, M. N. (2009). Early math matters: Kindergarten number competence and later mathematics outcomes. *Developmental Psychology*, 45, 850–867. doi:10.1037/a0014939
- Kaufman, A. S., and Kaufman N. L. (1993). *K-SEALS Kaufman survey of early academic and language skills: Manual*. USA: Pearson Assessments.
- Lampard, J. E., Voigt, M., & Bornstein, M. H. (2000). Urban and rural parenting. In L.Balter (Ed.), *Parenthood in America: An encyclopedia*. Santa Barbara, CA: ABC-CLIO Press.
- Lee, V. E., & Burkham, D. T. (2002). Inequality at the starting gate: Social background differences in achievement as children begin school. Washington, DC: Economic Policy Institute. Retrieved at January 12, 2018, from <http://eps1.asu.edu/epru/articles/EPRU-0603-138-OWI.pdf>
- Linares, L. O., Heeren, T., Bronfman, E., Zuckerman, B., Augustyn, M., & Tronick, E. (2001). A mediational model for the impact of exposure to community violence on early child behavior problems. *Child Development*, 72(2), 639–652.
- Miller, P. & Votruba-Drzal, E. (2013). Early academic skills and childhood experiences across the urban-rural continuum. *Early Childhood Research Quarterly*, 28, 234–248. doi.org/10.1016/j.ecresq.2012.12.005
- Morrow, L. M. (2007). *Developing literacy in preschool*. USA: The Guilford Press.
- Powell D. R. & Diamond, K. E. (2012). Promoting early literacy and language development. In R. C. Pianta (Ed) *Handbook of Early Childhood Education* (pp.194-216). NY: Guilford Press.
- Riley, J. (2006). *Language and literacy 3-7, creative approaches to teaching*. London: SAGE Publications.
- Roscigno, V. J., Tomaskovic-Devey, D., & Crowley, M. (2006). Education and the inequalities of place. *Social Forces*, 84(4), 2121–2145.
- Snow, C. E., Burns, M. S., & Griffin, P. (Eds.). (1998). *Preventing reading difficulties in young children*. Washington, DC: National Academy Press.
- Strickland, D. S., & Riley-Ayers, S. (2007). *Literacy leadership in early childhood*. USA: Teachers College Press.
- Uyanik, O. & Kandir, A. (2014). Adaptation of Kaufman Survey of Early Academic and Language Skills to Turkish Children Aged 61 to 72 Months (Educational Sciences: Theory & Practice), 14(2), 682-692. doi: 10.12738/estp.2014.2.1682.

- Vernon-Feagans, L., Gallagher, K., & Kainz, K. (2010). The transition to school in rural America: A focus on literacy. In J. Meece, & J. Eccles (Eds.), *Handbook of research on schools, Schooling, and human development* (pp.163-184) New York, NY: Routledge, Taylor, & Associates.
- Wachs, T. D., & Camli, O. (1991). Do ecological or individual characteristics mediate the influence of the physical environment upon maternal behavior? *Journal of Environmental Psychology, 11*(3), 249–264. [doi.org/10.1016/S0272-4944\(05\)80186-0](https://doi.org/10.1016/S0272-4944(05)80186-0)
- Whitehurst, G. J., & Lonigan, C. J. (2001). Emergent literacy: Development from prereaders to readers. In S. B. Neuman & D.K. Dickinson (Eds.), *Handbook of early literacy development* (pp. 11–29). New York: Guilford.

# Temperament and Resiliency as Predictor Factors of Preschoolers' School Readiness

Alev Onder, Asude Balaban Dagal, Dilan Bayindir

## 1. Introduction

The holistic definition of the school readiness concept includes “physical well-being and motor development”; “social and emotional development”; “approaches to learning”; “language development” and “cognition and general knowledge” (Kagan, Moore and Bredenkamp 1993 cited in UNICEF, 2012). School readiness can be briefly defined as the developmental stage that allow a child to respond adequately to school demands (Carlton and Winsler, 1999). An individual child is needed to have many different skills as literacy and numeracy skills and also behaviours as following directions, participating in learning activities and group works to succeed in school (Rouse, Brooks-Gunn and Mclanahan 2005). Emotional, social and conduct problems are risk factors for academic failure school dropout and attendance (Kellam et al., 1991; Moffitt, 1993). The school readiness is found as related with learning, schooling year, academic competencies and success (Blair et al., 2004; Kagitcibasi, Sunar and Bekman, 2001; La Paro and Pianta, 2000; Pianta and McCoy, 1997).

The school readiness level is found related with individual factors such as IQ (Butz, Pulsifer, Leppert, Rimrodt and Belcher, 2003) and temperament (Schoen and Nagle, 1994). Also environmental factors such as quality of childcare (Connell and Prinz, 2002), parental behaviors (Hill, 2001) and family income (Brooks-Gunn, Han and Waldfogel, 2002) are related with school readiness. The latest definitions of the school readiness does not only focus on the individual child, but focus on the interactions between the child and wide range of environmental and cultural factors that influences the development of the child (UNICEF, 2012). However, it could be said that individual characteristics of the child also shape the environmental outputs for him/her. For example, the related literature indicate that temperament of the child affects the parental behaviours (Yagmurlu et al, 2005). Also, ego resiliency is found as a protective factor from many kinds of environmental risk factors (Gizir, 2007). So, by considering the importance of individual child characteristics on school readiness, it could be said that it is needed to study the predictor individual factors on the school readiness in different cultural contexts.

Ego resiliency is defined as the tendency to adapt to and to develop against risk factors. This term is defined by Luthar (1993) as “behaviorally manifested success at negotiating salient developmental tasks, in spite of major stressors and possible underlying emotional distress” (p. 442). Children with higher levels of ego resiliency could continue their positive development against such individual risk factors as premature birth, chronological illness and early negative experiences, and such environmental factors as parental abuse and neglect, poverty (Gizir, 2007). Some individual and environmental factors are accepted as related with the level of ego resiliency. One of these individual factors is the temperament of the child. Having an easy temperament is seen as a related factor with ego resilience (Wyman, Cowen, Work and Parker, 1991).

The temperament is defined as individual differences on emotional, behavioural and attentional domains that are biologically rooted and partially constant (Fox and Henderson, 1999; Prior, 1992; Rothbart, 1989 cited in Yagmurlu, Sanson and Bahar-Koyden, 2005). Yavuzer (2006) states being cheerful, shy or quick tempered as some of the temperamental examples that are a part of the personality. Prior, Sanson and Oberklaid (1989 cited in Yagmurlu et al., 2005) claims there are 4 different temperament characteristics between 3 and 7 years of age. These are reactivity, persistence, approach/withdrawal and rhythmicity. Reactivity refers to the readiness to react a stimuli and it is found related with the problematic social behaviors (Sanson, Smart, Prior, Oberklaid and Pedlow; 1994). Persistence refer to the child's ability to stay and focus on a task. Children who are persistent could attend a task for a long period of time, so this related with social competency (Kyrios and Prior, 1990) and academic competence. Approach or Withdrawal refers to how the child responds to new



people, situations or environments. The predictivity of the child's biological functions such as routine in eating and sleeping habits, how easily s/he get tired, could be named as rhythmicity. There is a reciprocal relationship between the temperamental characteristics and environmental factors. The temperamental characteristics of a child affect the parental behaviours (Yagmurlu et al., 2005) and also child rearing practices that are affected by cultural expectations effect the development of temperament. A culture a child born in influences the development of temperament by effecting how people perceive and respond to a child with different temperament characteristics and by favoring temperament characteristics that are consistent with culturally approved behaviours in family or school kind structures (Kerr, 2001 cited in Zhou, Lengua and Wang, 2009).

It is crucial to determine the individual differences of children in order to adapt the educational and interventional programs and strategies according to their needs and to increase their school readiness to support their future academic success. Also by considering that cultural expectations and rules shape resiliency and temperamental characteristics that are important factors which effect the level of school readiness, it could be stressed upon that these issues are needed to be tested in different cultural contexts. However the number of studies that examine the relationship between resiliency and temperamental characteristics of preschoolers with their school readiness are very limited. So, the aim of the study was decided as to investigate the predictor effects of resiliency and temperamental characteristics on their school readiness level.

## 2. Method

### 2.1. Design of the study

The study, which is aimed to examine the predictive effects of temperament characteristics and resiliency of preschool children on the level of their school readiness, is designed to employ survey method.

### 2.2. The sample of the study

The sample consists of randomly selected 54-77 months olds preschoolers who attend preschools in Istanbul. Totally, 395 children participated in the study. The mean of age of the participant children is 64,75 months. The distribution of the Turkish population by the socioeconomic status was taken into account and 70,6 % of the participants were taken from medium, 14,4 % from low and %14,9 from high socio economic status. The demographic information on gender of children, the type of preschools they have attended and socioeconomic status of their families were presented in the following table.

**Table 1:** Demographic information on participant children and their parents

	<i>f</i>	%
<b>Gender of the child</b>		
Girl	191	48.8
Boy	204	51.6
<b>Type of the School</b>		
Private	167	42.3
Public	228	57.7
<b>Socioeconomic status</b>		
Low	57	14.4
Middle	279	70.6
High	59	14.9

### 2.3. Data Collection Tools

**2.3.1. School Readiness Scale-Short Form:** School Readiness Scale is developed by Baydar, Guroglu and Birdinc (2003 cited in Baydar et al., 2010). This scale assesses the level of children's school readiness according to perceptions of their mothers. The scale consists of 106 items and 7 subscales in

## Temperament and Resiliency as Predictor Factors of Preschoolers' School Readiness

total. The 15 itemed short version of the scale was used in the study of early childhood developmental ecologies in Turkey and the found alpha value is .908. The short version of the scale could differentiate the children who have problems at school and not.

**2.3.2. Short Temperament Scale:** Short Temperament Scale that was developed by Prior, Sanson and Oberklaid (1989) was translated into Turkish by Kumru, Sayil and Yagmurlu (2006 cited in Baydar, Kuntay, Goksen, Yagmurlu and Cemalcilar, 2010). It was adapted into Turkish by Yagmurlu and Altan in 2010 for 46 and 70 months old pre-schoolers. This 6 pointed likert typed scale consists of 30 items. The reliability scores of the approach/withdrawal subscale was found as .75, reactivity as .69, persistence as .75. and rhythmicity as .63.

**2.3.3. Children's Ego Resiliency Scale:** Children's Ego Resiliency Scale that was developed by Eisenberg et al. (1996) is an adaptation of Block Q-Sort. It aims to determine the ego resiliency levels of preschool and primary school aged children. There are totally 12 items in the scale and it is a 9 pointed likert type scale. There is no any subscales of the scale. As the scores the children get increase, it is accepted that the ego resiliency of the children increase. It was adapted into Turkish by Onder and Gulay-Ogelman in 2011. The cronbach alpha value of the Turkish version of the parent form is .89.

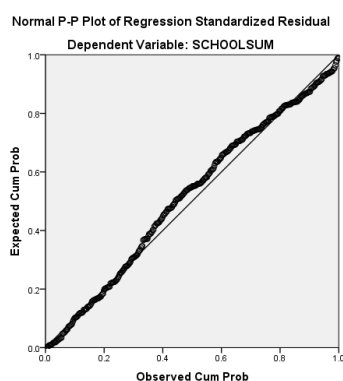
### 2.4. Data Collection

All the permissions to use the scales were taken. Then, the scales were distributed to the randomly selected preschools. The temperamental characteristics, ego resiliency and school readiness levels were determined by parent evaluation by sending the scales to parents through teachers.

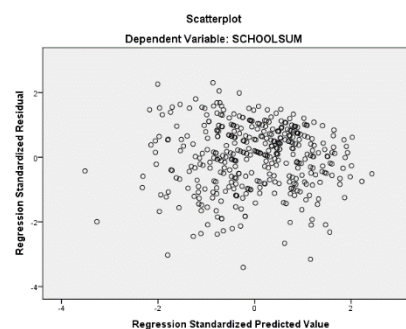
### 2.5. Data Analysis

The collected data was analysed by using SPSS 21.0. Correlation and multivariate stepwise regression analyses were run. In stepwise regressions decisions about the order in which predictors are entered into the model are based on mathematical criterion (Field, 2009). Pearson correlation analysis was run to examine if there was a significant relationship between school readiness, temperament and ego resiliency level. Then multivariate regression analysis was done to study the predictor effects of temperamental characteristics and the level of ego resiliency on school readiness. During the analysis of the data the level of significance was accepted as 0.05.

Before performing regression analysis, it was tested if there were any extreme values and it was found that the "linearity" and "multi variable normality" assumptions of the regression analysis have been met (Sipahi, Yurtkoru and Cinko, 2006). Also, the graphs of the standardized deviated values and standardized predicted values indicated that the linearity assumption has been meet (Figure 1). The distribution should be normal for standardized predicted values and deviations to be able to apply regression analysis. If the observed and predicted cumulative distribution graph is examined, it could be said that there is no important deviations (Figure 2).



**Figure 1:** The expected and observed cumulative probability



**Figure 2:** Standardized predicted values and deviations

In addition to the assumptions stated above, the normal distribution of the residuals that enable the multivariate regression (Figure 3), also the stability of the variance of residuals and no correlation between residuals assumptions were met.

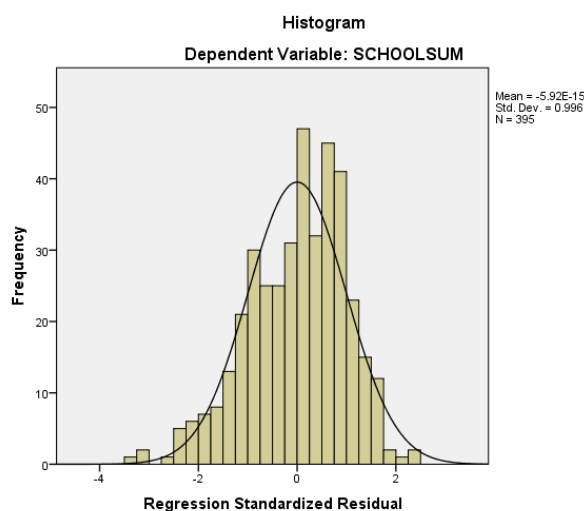


Figure 3: Normality graph of school readiness

### 3. Results

#### 3.1. The findings on correlations of the variables

Correlation analysis was done to test the relationships between variables. The correlation values, mean and standard deviation values on relationship between school readiness, temperament and the level of ego resiliency was presented in the Table 2.

Table 2: The basic correlation, mean and standard deviation scores of the relationships between dependent and independent values

	School Readiness	Ego Resiliency	Temperament Approach/ Withdrawal	Temperament Persistence	Temperament Rhythmicity	Temperament Reactivity
<b>Ego Resiliency</b> Total	.313**					
<b>Temperament</b> Approach/ Withdrawal	.089*	.055				
<b>Temperament</b> Persistence	.437**	.232**	.062			
<b>Temperament</b> Rhythmicity	.281**	.131*	.119**	.325**		

## Temperament and Resiliency as Predictor Factors of Preschoolers' School Readiness

**Temperament**

Reactivity	-.106*	-.007	-.170**	-.237**	.203*	-
Mean	4.326	5.603	4.014	3.889	4.260	2.901
Ss	<u>.432</u>	<u>1.073</u>	<u>.944</u>	<u>.916</u>	<u>.793</u>	<u>4</u>

N=395, \*p<.05, \*\*p<.01

As could be seen from Table 2, the basic correlation analysis does not indicate any significant relationships between approach/withdrawal and ego resiliency, and between reactivity and ego resiliency values. It was found that the total score of the school readiness significantly correlated with ego resiliency total score and all types of temperament, approach/withdrawal, persistence, rhythmicity and reactivity at  $p<.05$  and  $p<.01$  significance level. The direction of the relationship between school readiness and reactivity is negative. However, none of this significant relation levels higher than .70. Therefore multivariate regression analysis can be applied under these conditions. The findings indicate that the degree of the relations between school readiness and persistence subscale of the temperament is higher than the other relations.

**3.2. Findings on School Readiness**

Multivariate regression analysis step by step method was applied to test the effects of the level of ego resiliency and the presence of temperamental characteristics (as persistence, rhythmicity, reactivity and approach/withdrawal) on the level of school readiness of pre-schoolers. This step by step analysis indicated that the level of ego resiliency and persistency and rhythmicity predict the level of school readiness. The following table summarizes these findings.

**Table 3:** Multivariate regression analyses for school readiness

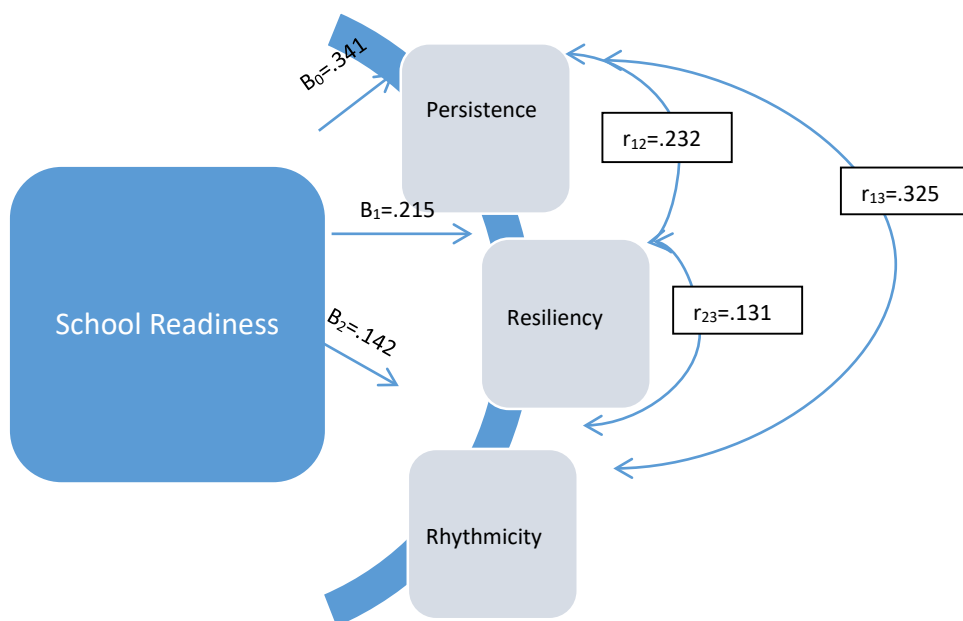
	Unstandardized Coefficients		Standardized Coefficients	t	Sig.
	B	Std. Error	Beta		
(Constant)	2.887	.138		20.902	.000
Persistence	.161	.022	.341	7.238	.000
Egoresiliency	.087	.018	.215	4.785	.000
Rhythmicity	.077	.025	.142	3.075	.002
3.model R <sup>2</sup>	.256				

Dependent variable: School readiness level

Model predictor variable- ego resiliency, persistence and rhythmicity

The findings of the regression analysis indicated that the linear combination of the ego resiliency, persistence and rhythmicity predict the level of school readiness ( $R^2 = .25$ ,  $F(3, 44, 859)$ ;  $p<.05$ ).

The values of the regression equation indicated that the ego resiliency ( $\beta = .215$ ), and two domains of temperament persistence ( $\beta = .34$ ) and rhythmicity ( $\beta = .14$ ) significantly predicts the level of school readiness of pre-schoolers. It can be claimed that the founded model is statistically significant to explain the school readiness of children because there is not a problem on multivariate correlate and covariance about regression assumptions and also the residuals were normally distributed.



**Figure 4:** The suggested model

#### 4. Discussion

The findings of the research indicated that temperament and the level of ego resiliency are predictor factors for school readiness. It could be said that the findings of the current research indicated the importance of individual differences of preschoolers for school readiness.

First of all, one of the research findings indicated that the correlation between the level of school readiness and ego resiliency were parallel to the findings of related literature. According to Prince-Embury (2015) resiliency in children and adolescents was related to academic achievement, school attendance and school completion. This finding is parallel to the research done by Kwok, Hughes and Luo (2007) indicated that resiliency is a predictor factor for concurrent and future achievement by administrated achievement test in the first grade and 1 year later to 445 children.

Also, the school readiness was found as related with some domains of the temperament. There were related research found relations between temperament and school adjustment (Blair et al., 2004, Carey, Fox and McDevitt, 1977, Zupancic and Kavcic, 2011) and academic achievement (Blair et al., 2004).

Also the regression analysis indicated that persistence and rhythmicity domains of the temperament predict the level of school readiness. The strongest relation was found between school readiness level and persistence domain of the temperament. The persistence allowed a child to focus on tasks, maintain his/her motivation that are important for school success. Furthermore, persistent children were better to analyse socially expected behaviours and behave according to these expectations (Yagmurlu et al., 2005). In a research, which was done with pre-schoolers, findings indicated that pre-schoolers' persistence was related to their academic skills two years later and early cognitive-linguistic skills (Mokrova et al., 2013).

The most interesting finding of the research was that rhythmicity was found as an important indicator of school readiness. It can be said that mothers give importance rhythmicity of their children, their sleeping and eating routines are accepted as important predictors for school readiness level by mothers of preschoolers.

Also the relationship between resiliency and temperament was tested. Ego resiliency was found related with persistence and rhythmicity domains of the temperament. This finding supports the results

of previous research which indicated a significant relationship between these two variables (Hutchinson, Stuart and Pretorius, 2010).

On the other hand Pearson correlation analysis revealed that while persistence and rhythmicity had positive relation with school readiness, reactivity was negatively correlated. This relation was found as negative. Similarly, Yoleri (2014) found that reactivity trait of temperament is associated with school adjustment of children in a negative way. If children indicate higher levels of reactivity this predicts the school adjustment negatively. Ari and Yaban (2016) found that children show high levels of reactivity have lower emotion regulation skills and these children show more aggressive behaviours. Reactivity was negatively associated with social competence and academic success. It can be said that reactivity affects school readiness in two negative ways by social incompetence (Sanson, Smart, Prior, Oberklaid and Pedlow, 1994) and academic incompetence.

By considering the findings of the research it can be stated that individual differences of children should be considered as factors affecting the school readiness. To state how the temperament and ego resiliency predict the level of school readiness, is critical to develop strategies and intervention programs to support this readiness. The data of the research was collected from parents of children. Teacher observation and other methods can be applied in later research to examine how the perceptions of parents are consistent with the findings of other methods.

## 5. References

- Ari, M. and Yaban, E. H. (2016). Okuloncesi donemdeki cocukların sosyal davranislari: Mizac ve duygu duzenlemenin rolu (Social behavior in preschool children: The role of temperament and emotion regulation), *Hacettepe Universitesi Egitim Fakultesi Dergisi /Hacettepe University Journal of Education*, 31(1): 125-141.
- Baydar, N., Kuntay, A., Goksen, F., Yagmurlu, B. and Cemalcilar, Z. (2010). *Turkiye'de erken cocukluk gelism ekolojileri arastirmasi*. [http://www.manevisosyalhizmet.com/wpcontent/uploads/2014/01/erkencocukluk\\_gelisimekolojileriarastirmasi.pdf](http://www.manevisosyalhizmet.com/wpcontent/uploads/2014/01/erkencocukluk_gelisimekolojileriarastirmasi.pdf), E.T. 31.09.2014.
- Blair, K. A., Denham, S. A., Kochanoff, A. and Whipple, B. (2004). Playing it cool: Temperament, emotion regulation, and social behavior in preschoolers. *Journal of School Psychology*, 42(6), 419-443.
- Carey, W.B., Fox, M. and McDevitt, S.C. (1977). Temperament as a factor in early school adjustment. *Paediatrics*, 60(4), 621-624.
- Carlton, M. P. and Winsler, A. (1999). School readiness: The need for a paradigm shift. *School Psychology Review*, 28, 338 – 352.
- Eisenberg, N., Fabes, R. A., Guthrie, I. K., Murphy, B. C., Maszk, P., Holmgren, R. and Suh, K. (1996), The relations of regulation and emotionality to problem behavior in elementary school children, *Development and Psychopathology*, 8, 141–162.
- Field, A. (2009). *Discovering Statistics*. 3rd edition. London: Sage Publication.
- Fox, N. A. and Henderson, H. A. (1999). Does infancy matter? Predicting social behavior from infant temperament. *Infant Behavior & Development*, 22(4), 445–455.
- Gizir, C. A. (2007). Psikolojik saglamlık, risk faktorleri ve koruyucu faktorler uzerinde bir derleme calismasi. *Turk Psikolojik Danisma ve Rehberlik Dergisi*, 3, 28, 113-128.
- Hutchinson, A. K., Stuart, A. D. and Pretorius, H. G. (2010). Biological contributions to wellbeing: The relationships amongst temperament, character strengths and resilience. *Journal of Industrial Psychology* 36(2), 844-854, DOI: 10.4102/sajip.v36i2.844
- Kagitcibasi, C., Sunar, D. and Bekman, S. (2001). Long-term effects of early intervention: Turkish low-income mothers and children', *Journal of Applied Developmental Psychology*, 22 (4), 333–361.
- Kellam, S., Werthamer-Larsson, L., Dolan, L., Brown, C., Mayer, L., Rebok, G., et al. (1991). Developmental epidemiology based on preventive trials: Baseline modeling of early target behaviors and depressive symptoms. *American Journal of Community Psychology*, 19, 563–584.
- Kyrios, M. and Prior, M. (1990). Temperament, stress and family factors in behavioural adjustment of 3-5- year-old children. *International Journal of Behavioral Development*, 13(1), 67-93.

- Kwok, O., Hughes, J. N. and Luo, W. (2007). Role of resilient personality on lower achieving first grade students' current and future achievement, *Journal of School Psychology*, 45, 61-82.
- La Paro, K. M. and Pianta, R. C. (2000). Predicting children's competence in the early school years: A meta-analytic review. *Review of Educational Research*, 70, 443 – 484.
- Luthar, S. S. (1993). Annotation: Methodological and conceptual issues in research on childhood resilience. *Journal of Child Psychol Psychiatry*, 34,441–454.
- Mokrova, I. L., O'Brien, M., Calkins, Susan D., Leerkes, E. M. and Marcovitch, S. (2013). The role of persistence at preschool age in academic skills at kindergarten. *European Journal of Psychology of Education*, 28(4), 1495-1503
- Onder, A. and Gulay-Ogelman, H. (2011). The reliability-validity study for the Ego Resiliency Scale (Teacher-Mother-Father Forms) for children aged between 5 and 6, *International Refereed Academic Social Sciences Journal*, 2(1): 5-21.
- Pianta, R. C. and McCoy, S. (1997). The first day of school: The predictive validity of early school screening', *Journal of Applied Developmental Psychology*, 18(1). 1–22.
- Prince-Embury, S. (2015). Assessing personal resiliency in school settings: The resiliency scales for children and adolescents. *Journal of Psychologists and Counsellors in Schools*, 25 (1). 55-65.
- Prior, M. (1992). Childhood temperament. *Journal of Child Psychology and Psychiatry*, 33, 249- 279.
- Rouse, C., Brooks-Gunn, J. and McLanahan, S. (2005). Introducing the issue. *Future of Children*, 15, 5–13. Retrieved from [https://www.princeton.edu/futureofchildren/publications/docs/15\\_01\\_FullJournal.pdf](https://www.princeton.edu/futureofchildren/publications/docs/15_01_FullJournal.pdf), in 27.05.2016.
- Sanson, A. V., Smart, D. F., Prior, M., Oberklaid, F. and Pedlow, R. (1994). The structure of temperament from age 3 to 7 years: Age, sex, and sociodemographic influences. *Merrill-Palmer Quarterly*, 40(2), 233-252.
- Schoen, M. J. and Nagle, R. J. (1994). Prediction of school readiness from kindergarten temperament scores. *Journal of School Psychology*, 32, 135 – 147.
- Sipahi, B., Yurtkoru, S. and Cinko, M. (2006). *Sosyal bilimlerde SPSS'le veri analizi [Data analysis using SPSS in social sciences]*. Beta Printed Publishings: Istanbul.
- Moffitt, T. E. (1993). Adolescence-limited and life- course-persistent antisocial behavior: A developmental taxonomy. *Psychological Review*, 100, 674–701.
- UNICEF (2012). *School Readiness: A conceptual framework*, Retrieved from [http://www.unicef.org/education/files/Chil2Child\\_ConceptualFramework\\_FINAL\(1\).pdf](http://www.unicef.org/education/files/Chil2Child_ConceptualFramework_FINAL(1).pdf) in 26 April 2016.
- Wyman, P. A., Cowen, E. L., Work, W. C. and Parker, G. R. (1991). Developmental and family milieu interview correlates of resilience in urban children who have experienced major life-stress. *American Journal of Community Psychology*, 19, 405-426.
- Yagmurlu, B. and Sanson, A. (2009). The role of child temperament, parenting and culture in the development of prosocial behaviors. *Australian Journal of Psychology*, 61(2), 77–88.
- Yagmurlu, B., Sanson, A. and Bahar Koymen, S. (2005). Ebeveynlerin ve çocuk mizacının olumlu sosyal davranış gelişimine etkileri: Zihin kuramının belirleyici rolü, *Türk Psikoloji Dergisi*, 20(55), 1-20.
- Yavuzer, H. (2006). *Cocuk Psikolojisi*, Istanbul: Remzi Kitapevi.
- Yoleri, S. (2014). The effects of age, gender and temperament traits on school adjustment for preschool children, *e-International Journal of Educational Research* 5(2), 54-66.
- Zhou, Q., Lengua, L.J. and Wang, Y. (2009). The relations of temperament reactivity and effortful control to children's adjustment problems in China and the United States, *Developmental Psychology*, 45(3): 724–739. doi:10.1037/a0013776.
- Zupancic, M. and Kavcic, T. (2011). Factor of social adjustment to school: Child's personality, family and pre-school. *Early Child Development and Care*, 181(4), 493-504.

# Quality, Knowledge Measure in the Performing of The Teaching of Natural Science and its Connection With Social Sciences

Ajka Aljilji

## Introduction

Modern methods and techniques of curriculum performing today represent a key tool through which the teaching process and the work of school institutions get a new dimension of quality. Given the overall presence of innovations, both technologically and pedagogically, the aim of this paper is to highlight the great importance of certain aspects of the use of some technologies and techniques of teaching in the branches of natural and social sciences in school institutions. Education should be open, flexible and capable of following scientific, technological, economic and social changes<sup>1</sup>. Quality is the most important phenomenon of our era, which is identified with the new philosophy of life<sup>2</sup>. In this sense, quality enables the individual to acquire quality in a teaching process that will be able to expand and make a better sense of quality of life. At the same time, it allows the teaching process to find a way to the common features between natural and social sciences as well as their continuous connection of existence. Knowledge and abilities can be defined as a dynamic concept that changes under the influence of all the changes in today's society. Natural sciences are extremely important for the development of children, especially for their intellectual development. The content of these sciences stimulates the development of formal-logical, hypothetical-deductive thinking. Children begin with their more serious studies from 11 to 12 years. At that time, the child is developmentally ready with adequate external influences to master with a new, higher stage of mental development, by formal thought<sup>3</sup>. Learning of natural sciences is a key impetus for the development of forms of formal thinking, which is called experimental thinking, that is, the opinion that is encountered during the performance of experiments. During the experiment, students learn about factors that can affect a certain phenomenon, and by systematically varying of these factors determine which of the factors or which combination of factors leads to a certain phenomenon. The contents of the quality of teaching represent the conception of the quality of teaching that is closely related to concepts such as:

- 1) Educational standards,
- 2) Reliability in teaching,
- 3) Adjustment of teaching to the age of students as well as their pre-knowledge.

In spite of all the problems we face in the teaching process, we must make a correlation or concept of quality in teaching that will connect science into a single educational system. Learning modes of students are largely conditioned by an environment that influences the formation of their opinions and attitudes and at the end of their lifestyle.

## Research Techniques

In all empirical research with serious educational tendencies, it seeks to gather as much of the relevant empirical evidence. Different techniques are used for this purpose. The choice of techniques for carrying out teaching and data collection is carried out in accordance with the nature of the problem and the tasks set and the acquired knowledge of the students. In order to gather all the essential elements of the subject of research, it is necessary to use several methods and techniques in sociological research in teaching and teaching content.

## Examination

The examination, conversation and questionnaire are among the most frequently used techniques for collecting data about man and society. Conversation can be defined as collecting data through dialogue, with the aim of using the results for educational purposes. The test is a form, a list of pre-assembled



and standardized questions that seek written knowledge of certain phenomena. The test is important because in it, notifications are provided without the help of a teacher who conducts the interview, the common thing is that the questions must be formulated well and aligned with the level of schooled content. Student tests must be adapted to their age and the environment. With this technique we will best see the achieved knowledge in the field of natural and social sciences as well as their interconnection in the teaching techniques themselves.

### **Effective Teaching**

Effective teaching is socially challenging because of the possible existence of unresolved conflicts and insufficiently researched values represented in the environment in which the school institution is located. Above all, effective teaching requires teachers to take into account previous student knowledge, to communicate clearly with them, and to stimulate them to think, communicate and learn. A good approach to starting the learning of any matter is to look at everything that is already known to the individual. We often find ourselves in a situation where we think we know more than we really know. We can remember some information, but we often face the problem when we need to apply it. This signals that we have to go a step back and revise the previously learned. This approach to learning, we can use it and apply it to school institutions, in order to increase the quality of the teaching process. Most teachers think that they know more about the implementation of the teaching process than they really know, because the teaching process in school facilities is a very complex process. It takes years of experience to fully master it, but even then there will be room for improving and improving the quality of lectures.

### **Comparative Method**

The comparative method is highly appreciated and often applied in natural and social sciences. The comparative method makes it possible to compare different societies and cultures, different phenomena, but also the same phenomena in various societies. The goal in all these cases is to find similarities and differences and to explain them. A comparative method was used even in his time by Aristotle, and he demands that the conditions for comparison of phenomena should be fulfilled, that is, that they are a certain basis for comparison. In social research, a comparative method can be applied as a substitute for an experiment.

### **Teaching By Discovery**

Departures in nature, direct knowledge of the social environment, socially useful work, the adoption of health habits, help in the development and building of student culture. The highlighting of educational components helps to form the whole personality. Problems occur every day, in all areas of human activity, which imposes the need for students to be trained for their successful resolving during regular education. This teaching develops critical thinking of students and is gradually noticed in solving all complex tasks and applying the acquired knowledge in *practice*. *Troubleshooting is the highest form of learning. With this form of learning, thinking and creativity is initiated*<sup>4</sup>. This form of teaching is interesting, creative, it makes students curious to become independent, helps students to think, develop with students of creative ability, so this kind of teaching through problem solving should be the satisfaction of teachers and students. Six steps can be distinguished in solving the teaching problem:

- 1) Problem setting: creating a problem situation by teachers and perceiving problems from students;
- 2) Finding the principle of problem solving. At this stage, the student seeks familiar elements and thus directs his efforts;
- 3) Separation (explaining) of general direct problems. At this stage, the student approaches the problem of the model or scheme offered to him;
- 4) Solving the problem itself;
- 5) Making independent conclusions and putting into a wider system;
- 6) Checking the conclusions in new situations.

Different levels of learning problems exist, which depends on the students' intellectual efforts and their cognitive activity. Therefore, the quality of teaching can be determined to a certain extent by measuring the quality of students' knowledge. In the organization of teaching the problem has a certain value and, most importantly, its values have actually contributed to the development of students' thoughtful activities, which provides opportunities for regular feedback, accustomed students to apply them in practice to the existing knowledge in new situations and allows the teacher to, based on feedback, corrects the teaching process, removes weaknesses and successfully achieves the goal and task.

### **Scientific Method**

The scientific method does not rely on intuition. The intuition method was present in the early stages of scientific knowledge, so it cannot be ignored as part of a scientific method. Knowledge then relies on an obvious or only obviousness. The development of critical thinking has shown that the so-called self-incisors are the most common result of the habit of daily routine and the result of upbringing. However, as a moment of creative creativity, intuition plays a role in the research process. A scientist-student must be self-critical towards himself, according to his views and research in general. Therefore, the research process is constantly subjected to suspicion and checking the results obtained. The scientific method encourages and develops doubts in everything that has not been proven and verified. Science seeks answers to very practical questions. Science is based on observation, which is, collecting data. Science is an intellectual aspiration. Observation and data collection are not the ultimate goals. The data must be analyzed and used to find out everything that surrounds us. Scientists often make predictions and test predictions using experiments. Science is systematic. It is rigorous and methodical, requiring that tests be repeated so that the results can be checked. So, science can be seen as a way of thinking, but also as a method of work, a process that requires scientists to ask questions, formulate and test hypotheses through experimentation. This process is now known as the scientific method, and its basic principles are used by the researchers in each discipline.

### **Steps Of The Scientific Method**

The scientific method, according to the presented, is an important method of scientific knowledge, developed during the evolution of scientific knowledge of different sciences. Basically, it is a complex method that involves certain phases, assumptions and conditions in order to be successful. The elements of the scientific method are various methodological methods, that is, phases, which for the purpose have creative creation of scientific knowledge. The method consists of a series of logical procedures. The phases of the scientific method are: problem definition, data collection, hypothesis formulation, experiment, hypothesis testing and conclusion. By introducing a scientific method in teaching, students adopt a certain way of thinking (hypothesis setting, their experimental confirmation, conclusions and solving problems), which makes it easier to solve problems not only in science, but also in everyday life<sup>4</sup>.

- 1) Definition of the problem
- 2) Data collection
- 3) Formulation of the hypothesis
- 4) Experiment
- 5) Testing hypothesis
- 6) Conclusion
- 7) Unspecified hypothesis
- 8) Confirmed hypothesis

Based on one or more confirmed hypotheses, a conclusion is drawn on the question raised, which can later serve to formulate a new theory. The theory is a hypothesis that has survived a series of checks. The highest level is the mathematical formulation of the investigated phenomenon. Theories can be purely qualitative (such as evolution theory) and quantitative (phenomena are explained in mathematical form). The scientific method shown in this way may seem abstract, but it is not so that we can be convinced of simple examples from everyday life.

### Conclusion

Developing creative thinking among students is a sufficient reason for organizing classes. This creates favorable conditions for greater activity of teachers and pupils in achieving the planned content. All the advanced methods in the teaching process can be applied in the teaching of natural and social sciences, finding among themselves the connections that enable us to perform teaching successfully. This organized teaching enables us to acquire quality knowledge. Content processing in a more modern way requires more time and engagement from processing in a classic way, but results are therefore certainly better. The organization of teaching lessons and teaching methods are chosen to maximally encourage and maintain the student's mental activity and contribute to the development of their mental abilities. In accordance with the analysis of the given issues in this paper, we come to the conclusion that the importance of following trends of modern methods of teaching in schools is very important in order to increase the quality of teaching. For this reason, school institutions must follow the development and use of both new pedagogical and technological solutions to prevent their own way and system of work. It is very important that employees in school institutions accept and use new technologies in the realization of the teaching process. By focusing on the use of modern technologies, as well as understanding the needs and ways of most suitable acquisition of students' knowledge in linking methods and techniques of teaching in natural and social sciences, school institutions will be able to justify the purpose of their existence.

### Literature

1. Avramović (2004): Zoran Avramović, Society and school: problem of knowledge selection, Proceedings of knowledge and achievements, ed. Stevan Krnjajić, Belgrade: Institute for Pedagogical Research, 11-25.
2. Antonijević (2006): Radovan Antonijević, Knowledge Learning System, Belgrade: Institute for Pedagogical Research. Blagdanic (2009): 3. Poparić G. (2010), Preparation for Teaching, Logos, Belgrade, 2010;
3. Vilotijević, M. (1998): Methodology of biology teaching. Podgorica.
4. Brkanlić, S., Gardašević, J., Ćirić, M., Vučurević, T., Tešić, A., Ožegović, L., (2012): Significance of new technologies for performing teaching process in higher education institutions, XXII Skup Trendovi Development:
5. Gaugh H.G. (2009): Scientific Method in practice, Cambridge: Cambridge University Press, available at <http://www.borojevic.com>, Methodology of experimental scientific work, University of Novi Sad.
6. Radojka D. (1973): Methodology of chemistry teaching, Light, Sarajevo.
7. Hališić R., Kesler M., (2005): Methodology of chemistry teaching and demonstration trips, Scientific book, Belgrade.

# **The Investigation of The Relationship Between Attachment Styles and Social Problem Solving Skills of Preschool Children**

Elif Yilmaz, Gulcin Guven, Turker Sezer

## **1. Introduction**

Family with its social, economic and cultural aspects is effective on an individual's life, on the child's psychological development and behaviors (Tumkaya, 2012). Children, through the interaction they established with their parents, record the information that they acquired from the outside world (Hendrix, & Hunt, 2001). For that reason, the attitudes and behaviors of the parents have a strong effect on the development of their children (Gulacti, 2012). One of the theories deals with the impacts of the parents on the child and the parent-child relationship is attachment theory (Ozgun, 2013). Following the research handled by Bowlby and Ainsworth, attachment theory defines a strong bond formed between two people and basically explains the process of attachment of the child to the parent (Bretherton, 1992). According to this theory, closeness of the child to her caregiver and the caregiver's effective sensitivity to the child provides a secure basis for the child to explore his or her environment (Kagitcibasi, 2012). While the person who is taken care of the baby is usually the mother, the figure of attachment is excepted as the mother in the literature of attachment theory (Bowlby, 1980). While the children experience to establish a connection in their lives firstly with their mothers, their attitudes are important for children to acquire social skills such as interpersonal relation abilities, sense of responsibility, sharing, helping and cooperation (Schaffer, 2004; Sezer, & Yoleri, 2011). These positive social skills are defined as prosocial behavior and are rubricated under the social problem solving skills. Social problem solving is defined as a cognitive-behavioral process through which the children exhibit behaviors of problem orientation, definition, generation of solutions in order to cope with problematic situations she faced in everyday life (D'Zurilla, Chang, & Sanna, 2003). These skills, which are also called as interpersonal (cognitive) problem solving in literature, besides requiring a cognitive process where alternative solutions are generated for problematic situations, also requires the individual to exhibit proper reaction being aware of her own emotions and the other's ones (Dincer, 1995).

Social problem solving skills are consist of negative and positive orientations and cognitive and behavioral patterns as rational, impulsive and avoidant styles (Nezu, Nezu, & D 'Zurilla, 2006). It can be said that the skills and the competencies of children in solving the conflicts and problems that they encounter in social realm are affected by many variables. However, the initial researches in this area focused on the social problem solving skills of the children and the parent relations and the quality of the first contact (Dubow, & Tisak, 1989; Dubow, Tisak, Causey, Hryshko, & Reid, 1991; D 'Zurilla, & Nezu, 1999; Kazdin, Siegel, & Bass, 1992; Pettit, Dodge, & Brown, 1988). In the light of the researches on the social problem solving skills of the children and the parent relations, the effect of attachment styles, as the important indicators of parent-child relations, on social problem solving skills is intriguing. In this context, this research aims to examine the relationship between attachment styles and social problem solving skills. It also aims to examine this relationship between attachment styles and social problem solving skills in terms of the gender of the children and the educational status of the mothers.

## **2. Method**

### **2.1. Research Model**

This research which examines the relationship between the attachment styles and the social problem solving skills of the preschool children is designed in relational survey model.

## 2.2. Study Group

The study group of the research consists of 187 children, all of whom are 60-72 months old. The children are attending in the 2015-2016 academic year six kindergartens which are chosen according to the availability principle from the independent preschool institutions in the districts of the Anatolian side of Istanbul, namely in Kadikoy, Maltepe and Uskudar.

Table 1 shows the demographic characteristics of the children and their parents in the study group.

**Table 1.** Frequency and rate distribution of the demographic characteristics of the children and their parents in the study group

Demographic Characteristics		<i>f</i>	%	
<b>Mother</b>	<b>Age Group</b>	33 years of age and under	61	32.6
		34 - 41 years of age	102	54.5
		42 years of age and older	24	12.8
	<b>Educational Status</b>	Primary education	27	14.4
		Secondary education	57	30.5
		Higher education	103	55.1
<b>Father</b>	<b>Age Group</b>	33 years of age and under	31	16.6
		34 - 41 years of age	91	48.7
		42 years of age and older	65	34.8
	<b>Educational Status</b>	Primary education	16	8.6
		Secondary education	54	28.9
		Higher education	117	62.6
<b>Child</b>	<b>Gender</b>	Female	92	49.2
		Male	95	50.8
	<b>The Number of Siblings</b>	Only child	52	27.8
		One sibling	92	49.2
		Two or more siblings	43	23.0
	<b>The Family's Monthly Income</b>	2000 TL and under	31	16.6
2001 – 4000 TL		54	28.9	
4001 – 6000 TL		67	35.8	
6001 TL and above		35	18.7	

According to table 1, 61 (32.6%) of the mothers are 33 years and under, 102 (54.5%) are between the ages of 34-41 and 24 (12.8%) are 42 years old and over; and 31 (16.6%) of the fathers are 33 years and under, 91 (48.7%) are between the ages of 34-41, 65 (34.8%) are 42 years old and over. 27 (14.4%) of the mothers of the children in the study group graduated from primary education, 57 (30.5%) from secondary education and 103 (55.1%) from higher education; while 16 (8.6%) of the fathers from primary education, 54 (28.9%) from secondary and 117 (62.6%) from higher education. 92 (49.2%) of the children participating in the survey are female, 95 (50.8%) are male; and 52 (27.8%) are only child, 92 (49.2%) have one sibling, 43 (23%) have two or more siblings. Examination of the income levels of the parents of the children in the study group shows that 31 (16.6%) of them are earning 2000 TL or under, 54 (28.9%) are in the range of 2001 – 4000 TL, 67 (35.8%) are in the range of 4001 – 6000 TL; 35 (18.7%) are 6001 TL or above for a month.

## 2.3. Data Collection Tools

Three data collection tools are used in the research. These are; Personal Information Form, Doll Family Story Completion Test-TR, and Wally Social Problem-Solving Test.

### 2.3.1. Personal Information Form

The Personal Information Form which is prepared by the researchers was used for collecting demographic data on the educational status and the age groups of the parents, children's gender and the number of siblings, and the socio-economic status of the family.

### 2.3.2. Doll Story Completion Task

Doll Story Completion Task is developed for evaluating children's Secure Zone Scenarios by Granot and Maysseles (2001). Scale is based on the narrative technique developed by Bretherton, Ridgeway and Cassidy (1990). Scale is consist of 6 stories, and the first one is for warm-up. In the other 5 stories, which are about attachment, the anxiety that the content creates is used for triggering the Secure Zone Scenarios. Scale is adapted in Turkish and tested for reliability and validity by Uluc (2005). In this research the confidence coefficient KR 20 is measured as .73.

### 2.3.3. Wally Social Problem-Solving Test

This test is formed as the combination of the Preschool Problem-Solving Test of Spivak-Shure (1985) and the Child Social Problem-Solving Test of Rubin-Krasnor (1986). The test is compiled by Carolyn Webster Stratton within "The incredible Years" project and adapted to Turkish by Yilmaz (2012). In the Wally Social Problem Solving Test, the children are shown 15 colored pictures narrating hypothetical problem situations and they are asked about what they would do when they face such a problem. The attitudes the child offered are categorized as prosocial and non-prosocial. Child is given a 1 point for prosocial attitudes and 0 for non-social ones. The test consists of different cards for girls and for boys. In this research the confidence coefficient KR 20 was measured as .81.

## 2.4. The Collection and the Analysis of the Data

Personal Information Form for the research on the relationship between the attachment styles and the social problem solving skills was delivered to the family through the teachers and assessed by parents. "Doll Story Completion Task" and "Wally Social Problem-Solving Test" were applied individually by the researchers and evaluated. SPSS software was used for the analysis of the data and KR-20 validity coefficient was calculated for reliability analyses of the Doll Story Completion Task and the Wally Social Problem-Solving Test. In the evaluation of the data, the independent groups t test, the Chi-square analysis, one-way analysis of variance (ANOVA) and Tukey test for determining between which groups there is a difference when there is a significant difference among groups according to ANOVA results were used. The significance level for all of the analyses has been considered as  $p < .05$ .

## 3. Findings

The findings of the research are presented in this section. T test results where the average scores of the social problem solving skills by the attachment styles of the children is examined are presented in Table 2.

**Table 2.** T test results for the average scores of the social problem solving skills by the attachment styles of the children

	Attachment Style	n	$\bar{X}$	Ss	t	Sd	p
<b>Social Problem Solving Skills</b>	Insecure attachment	33	9.36	2.82	-5.215	185	,000*
	Secure attachment	154	11.96	2.54			

\* $p < .05$

Table 2 shows that the average scores of the children in the Wally Social Problem-Solving Test differs in a statistically significant manner by their attachment styles to their mothers ( $t = -5.215$ ,  $p < .000$ ). Examination of the Wally Social Problem-Solving Test average scores by the children's attachment styles shows that the average scores of the children attached insecurely is 9.36 while it is 11.96 for

securely attached children. According to that, the social problem solving skills scores of the securely attached children is higher than the insecurely attached ones' scores.

Table 3 presents the results of the Chi-square analysis on attachment styles by the gender variable.

**Table 3.** Chi-square ( $X^2$ ) analysis results on attachment styles by the gender variable.

Gender	Attachment Style						
	Secure attachment		Insecure attachment		Total		
	n	%	n	%	n	%	
Female	81	88	11	12	92	100	
Male	73	76.8	22	23.2	95	100	
Total	154	82.4	33	17.6	187	100	
$X^2= 4,035$		$p =, 045 *$				$sd=1$	

\* $p < .05$

Table 3 shows that 88% of girls who participated in the survey are securely and 12% are insecurely attached to their mothers; while 76.8% of the boys are securely and % 23.2 are insecurely attached to their mothers. 33 of the 187 children participated in study are insecurely attached to their mothers and 22 of them are male. When the data is analyzed it is determined that attachment styles of the children to their mothers are significantly differentiated by the gender ( $X^2_{(sd=1, n=187)}= 4,035, p < .05$ ).

Table 4 presents the results of the Chi-square analysis on attachment styles by the mothers' educational status variable.

**Table 4.** Chi-square ( $X^2$ ) analysis results on attachment styles by the mothers' educational status variable

Educational Status of the Mother	Attachment Style						
	Secure attachment		Insecure attachment		Total		
	n	%	n	%	n	%	
Primary education	20	74.1	7	25.9	27	100	
Secondary education	48	84.2	9	15.8	57	100	
Higher education	86	83.5	17	16.5	103	100	
Total	154	82.4	33	17.6	187	100	
$X^2= 1,501$		$p= .472$				$sd=2$	

Table 4 shows that 74,1% of the children whose mothers have graduated from primary education are securely attached them while 25.9% are insecurely attached; 84,2% of the children whose mothers have graduated from secondary education are securely attached them while 15.8% are insecurely attached; and 83,5% of the children whose mothers have graduated from high education are securely attached them while 16.5% are insecurely attached. According to the table, there is no statistically significant differentiation in the attachment styles of the children by their mothers' educational background ( $X^2_{(sd=2, n=187)}= 1.501, p > .05$ ).

Table 5 presents the t test results of the social problem solving skills of the children by the gender.

**Table 5.** T test results of the score averages of the social problem solving skills of the children by the gender

	Gender	n	$\bar{X}$	Ss	t	Sd	p
Social Problem Solving Skills	Female	92	11.70	2.46	1.070	185	,286
	Male	95	11.27	3.02			

According to the table 5, there is no statistically significant differentiations in the averages of the children's Wally Social Problem-Solving Test scores by the gender of them ( $t=1,070, p > .05$ ).

Table 6 presents the one way variance analysis results of the children's social problem solving skills by the mothers' educational status.

**Table 6.** ANOVA results of the means of the children's social problem solving skills scores by the mothers' educational status

Source of Variance	Sum of Squares	Sd	Mean Square	F	p	Significant Difference
Intergroups	114.588	2	57.294	8.047	,000*	-Higher education/Primary education
Ingroup	1310.129	184	7.120			-Secondary education/Primary education
Total	1424.717	186				

\*p<.05

Table 6 shows a significant differentiation in the averages of the children's Wally Social Problem-Solving Test scores by the mothers' educational status ( $F_{(2,184)} = 8,047$ ,  $p < .05$ ). Groups are compared to each other in order to determine that between which groups the difference is located. Tukey test is applied since the variances have a homogeneous distribution. According to Tukey test results, there is a significant difference between the children of the mothers graduated from higher education and the children of the mothers graduated from primary education in favor of the former; and again, between the children of the mothers graduated from secondary education and the children of the mothers graduated from primary education in favor of the former.

#### 4. Discussion and Conclusion

The research reveals that the social problem solving skills differ by the attachment styles of the preschoolers to their mothers. It is determined that the average social problem solving skills scores of the children who are securely attached to their mothers are higher than the children who are insecurely attached. The research conducted by Tukoz (2007), as seems supporting our findings, resulting that the children's possibility of coping with the social problems become higher by their securely attachment to the mothers. When the literature on the effects of parent-child interaction on the child's social problem-solving skills was examined, it was found that there was a negative relationship between mothers' acceptance/rejection levels in the research by Tepeli and Yilmaz (2013) and the social problem solving skills of the children is decreased as the mother's rejection level increased. In this context, when the influence of the mother's acceptance level on social problem solving skills is taken into consideration, it is considered that the attachment style of the child to mother is an important variable for social problem solving skills.

When the results of the research were examined, it was seen that children's attachment styles to their mothers varied according to their gender. According to this, it is determined that girls are more securely attached to their mothers than boys. Similarly, it was determined by Turkoz (2007) that girls are more securely attached to their mothers in the study conducted with pre-school children. In a similar manner, in a study conducted by Granot and Mayseless (2001), it was found that girls were more securely attached than boys. In the research conducted by Akbag and Erden-Imamoglu (2010), it is seen that the gender variable is related to all attachment styles except careless attachment, which is one of the insecure attachment types. When studies in the field were examined, Kenny and Donaldson (1991) stated that girls were more strongly attached on their parents, while Sorokou and Weissbrod (2005) reported that girl children perceived the bond they had established with their mothers as more tight. Unlike these findings, it was found that the attachment style did not show any significant difference according to the gender variable in some studies in which the attachment style was examined in terms of gender (Kerns, 2008, Sozucecer, 2011, Sumer, & Sendag, 2009, Uluc, & Oktem, 2009). It can be interpreted that these differences arising as a result of the research are caused by the individual differences of the participants in the study group.

According to another result obtained in the study, the attachment styles of the pre-school children to their mothers do not differ according to the mothers' educational status variable. A research conducted by Cohn (1990) also provided findings supporting the results of this research. In addition, in



the literature there are also findings on that parental education predicts children's attachment styles (Cassidy, 1988, Crittenden, & Claussen, 2003, Seven, 2006). For this reason, it is thought that this difference is due to cultural influences or characteristics of study groups.

According to the results of the research, it was determined that social problem solving skills of pre-school children did not show any significant difference in terms of gender. Yilmaz (2016) found that the social problem solving skills of children did not differ according to the gender variable in the results of the research conducted with the children in ages between 48-72-month-old. In the study by Green, Cillessen, Recheis, Patterson and Hughes (2008), social problem solving strategies of children in the 6-year-old group were examined and it was determined that girls and boys preferred similar positive strategies. Studies conducted by Akbas (2005), Dereli (2008), Yilmaz and Tepeli (2013) also support this research result. In addition to this, there are also findings in the literature on that girls have more sophisticated social skills than boys and have less problematic behavior (Guven, Sezer, & Yilmaz, 2015; Walker, Irving, & Berthelsen, 2002).

According to the results of the study, it was found that the social problem solving skills of children were significantly differed by the variables of mother education status. According to this result, the social problem solving skill scores of the children of the mothers graduated from higher education and secondary education are higher than the mothers of primary school graduates. When the researches in the literature are examined, it is found that the social problem solving skills of the children in the pre-school years differ by the education level of the mother and this difference is generally in favor of the children of the mothers of higher education graduates (Akbas, 2005; Yilmaz, 2016).

As a result of the research, it can be suggested to test the effectiveness of comparative researches and experimental training programs on the attachment style to mothers and children's social problem solving skills by going through all the findings.

## 5. References

- Akbag, M., & Erden-Imamoglu, S. (2010). Cinsiyet ve baglanma stillerinin utanc, suçluluk ve yalnızlık duygularini yordama gucunun arastirilmesi [The prediction of gender and attachment styles on shame, guilt, and loneliness]. *Kuram ve Uygulamada Egitim Bilimleri/Educational Sciences: Theory & Practice*, 1(3), 145-166.
- Akbas, S. C. (2005). *Okul oncesi egitime devam eden alti yas grubu cocuklarin sosyal problem cozme becerilerinin incelenmesi* [The social problem solving skills of six years old children continuing to preschool education] (Unpublished master thesis). Hacettepe University, Ankara, Turkey.
- Bowlby, J. (1980). *Attachment and Loss: Sadness and Depression*. (Vol:3). New York: Basic Books.
- Bretherton, I. (1992). The origins of attachment theory: John Bowlby and Mary Ainsworth. *Developmental Psychology*, 28(5), 759-775.
- Bretherton, I., Ridgeway, D., & Cassidy, J. (1990). Assessing internal working models of the attachment relationship. In M. T. Greenberg, D. Cicchetti, & E. M. Cummings (Eds.), *Attachment in the Preschool Years: Theory, Research, and Intervention* (pp. 273-308). Chicago: University of Chicago Press.
- Cassidy, J. (1988). Child mother attachment and the self in six-years old. *Child Development*, 59, 121-134.
- Cohn, D. A. (1990). Child-mother attachment of six years old and social competence at School. *Child Development*, 61, 151-161.
- Crittenden, P. M., & Claussen, A. H. (2003). *The Organization of Attachment Relationships*. Cambridge: Cambridge University Press.
- Dereli, E. (2008). *Cocuklar icin sosyal beceri egitim programinin 6 yas cocuklarin sosyal problem cozme becerilerine etkisi* [The effect of the program of child social skills training on the skill of 6-year-old children's social problem solving] (Unpublished doctoral dissertation). Selcuk University, Konya, Turkey.
- Dincer, F. C. (1995). *Anaokuluna devam eden 5 yas grubu cocuklarina kisilerarasi problem cozme becerilerinin kazandirilmasinda egitimin etkisinin incelenmesi* [The examination of the effect of 'problem solving' training on the arquisition of interpersonal problem solving skills by five year old

- children attending a kindergarten] (Unpublished doctoral dissertation). Hacettepe University, Ankara, Turkey.
- Dubow, E. F., & Tisak, J. (1989). The relation between stressful life events and adjustment in elementary school children: The role of social support and social problem-solving skills. *Child Development*, 60(6), 1412-1423.
- Dubow, E. F., Tisak, J., Causey, D., Hryshko, A., & Reid, G. (1991). A two-year longitudinal study of stressful life events, social support, and social problem-solving skills: Contributions to children's behavioral and academic adjustment. *Child Development*, 62(3), 583-599.
- D'Zurilla, T. J., & Nezu, A. M. (1999). *Problem-Solving Therapy: A Social Competence Approach to Clinical Intervention*. New York: Springer Publishing Company.
- D'zurilla, T. J., Chang, E. C., & Sanna, L. J. (2003). Self-esteem and social problem solving as predictors of aggression in college students. *Journal of Social and Clinical Psychology*, 22(4), 424-440.
- Granot, D., & Mayseless, O. (2001). Attachment security and adjustment to school in middle childhood. *International Journal of Behavioral Development*, 25(6), 530-541.
- Green, V. A., Cillessen, A. H., Recheis, R., Patterson, M. M., & Hughes, J. M. (2008). Social problem solving and strategy use in young children. *The Journal of Genetic Psychology*, 169(1), 92-112.
- Gulacti, F. (2012). Turkiye'de ve dunyada erken cocukluk ve okul oncesi egitimi [Early childhood and pre-school education in Turkey and in the world]. In F. Gulacti, & S. Tumkaya. (Eds.). *Erken Cocukluk Egitimi [Early Childhood Education]*, (pp. 1-21). (2<sup>nd</sup> ed.). Ankara: Pegem Akademi Yayıncılık/Pegem Academy Publishing.
- Güven, G., Sezer, T., & Yılmaz, E. (2015). 60-72 aylık çocukların sosyal problem çözme becerileri ile benlik algıları arasındaki ilişkinin sosyo-ekonomik değişken açısından incelenmesi [Investigation of the relationship between social problem solving skills and self-perceptions of children aged 60-72 months in terms of socio-economic variables]. Paper presented at the 3<sup>rd</sup> Child Development and Education Congress, Ankara, Turkey.
- Hendrix, H., & Hunt, H. (2001). *Ailede İyilestirici Sevgi [Giving the Love That Heals]*. İstanbul: Kaknus Yayınları/Kaknus Publishing.
- Kagıtcıbaşı, C. (2012). *Benlik, Aile ve İnsan Gelişimi Kültürel Psikoloji. [Family, self, and human: Development across cultures]*. (3<sup>rd</sup> ed.). İstanbul: Koc Üniversitesi Yayınları/ Koc University Publishing.
- Kazdin, A. E., Siegel, T. C., & Bass, D. (1992). Cognitive problem-solving skills training and parent management training in the treatment of antisocial behavior in children. *Journal of Consulting and Clinical Psychology*, 60(5), 733-747.
- Kenny, J. A., & Donaldson, G.A. (1991). Contributions of parental attachment and family structure to the social and psychological functioning of first-year college students. *Journal of Counseling Psychology*, 38(4), 479-486.
- Kerns, K. A. (2008). Attachment in middle childhood. In J. Cassidy, & P. R. Shaver. (Eds.), *Handbook of Attachment: Theory, Research, and Clinical Applications*, (pp. 366-382). (2<sup>nd</sup> ed.). New York, US: Guilford Press.
- Nezu, A. M., Nezu, C. M., & D'Zurilla, T. (2006). *Solving Life's Problems: A 5-Step Guide to Enhanced Well-Being*. New York: Springer Publishing Company.
- Ozgun, O. (2013). Ebeveynlik ile ilgili kuramlar ve araştırmalar [Parenting theories and research]. In Z. F. Temel (Eds.). *Aile Egitimi ve Erken Çocukluk Eğitiminde Aile Katılım Çalışmaları [Family Education and Family Participation in Early Childhood Education]*, (pp.72-109), (2<sup>nd</sup> ed.). Ankara: Ani Yayıncılık/Ani Press.
- Pettit, G. S., Dodge, K. A., & Brown, M. M. (1988). Early family experience, social problem solving patterns, and children's social competence. *Child Development*, 59(1), 107-120.
- Rubin, K. H., & Krasnor, L. R. (1986). Social-cognitive and social behavioral perspectives on problem-solving. In M. Perlmutter. (Eds.). *Cognitive Perspectives on Children's Social and Behavioral Development*. The Minnesota Symposia on Child Psychology (Vol. 18, pp. 1-68). Hillsdale: Erlbaum.
- Schaffer, H. R. (2004). *Child Psychology*. Oxford, UK: Blackwell Publishing.

- Seven, S. (2006). *Yas cocuklarinin sosyal beceri duzeyleri ile baglanma durumları arasındaki iliskilerin incelenmesi [The relationship between social skills an attachment in six years old children]* (Unpublished doctoral dissertation). Gazi University, Ankara, Turkey.
- Sezer, T., & Yoleri, S. (2011). Okul oncesi cocugunun temel ozellikleri ve gereksinimleri [Basic characteristics and requirements of preschool child], In G. Uyanik-Balat. (Eds.). *Okul Oncesi Egitime Giris [Introduction to Pre-school Education]*, (pp. 43-82). (2<sup>nd</sup> ed.). Ankara: Pegem Akademi Yayıncılık/Pegem Academy Publishing.
- Sorokou, C. F., & Weissbrod, C. S. (2005). Men and women's attachment and contact patterns with parents during the first year of college. *Journal of Youth and Adolescence*, 34(3), 221-228.
- Sozucecer, Z. (2011). *Cocuklardaki davranis problemlerinin, baglanma stilleri, aile islevleri ve anne kabul algilari acisindan incelenmesi [Examining the behavior problems in children in terms of attachment security, family functions and perceptions of acceptance/rejection of the mother]* (Unpublished master thesis), Istanbul University, Istanbul, Turkey.
- Spivak, G., & Shure, M. B. (1985). ICPS and beyond: Centripetal and centrifugal forces. *American Journal of Community Psychology*, 13(3), 226-243.
- Sumer, N., & Sendag, M. A. (2009). Orta cocukluk doneminde ebeveynlere baglanma, benlik algisi ve kaygi [Attachment to parents during middle childhood, self-perceptions, and anxiety]. *Turk Psikoloji Dergisi/Turkish Journal of Psychology*, 24(63), 86-101.
- Tepeli, K., & Yilmaz, E. (2013). Social problem-solving skills of children in terms of maternal acceptance-rejection levels. *US-China Education Review*, 3(8), 581-592.
- Tumkaya, S. (2012). Okul oncesi egitim doneminde ailenin yeri ve onemi [Place and importance of family in pre-school education], In F. Gulacti, & S. Tumkaya. (Eds.). *Erken Cocukluk Egitimi [Early Childhood Education]*, (pp. 335-369). (2<sup>nd</sup> ed.). Ankara: Pegem Akademi Yayıncılık/Pegem Academy Publishing.
- Turkoz, Y. (2007). *Okul oncesi cocuklarda baglanma oruntusunun kisilerarasi problem cozme ve acik bellek sureclerine etkisi [Effects of attachment pattern on the processes of interpersonal problem solving and explicit memory in preschool children]* (Unpublished doctoral dissertation). Ankara University, Ankara, Turkey.
- Uluc, S. (2005). *Okul oncesi cocuklarda benlige iliskin inanclar, kisilerarasi semalar ve baglanma iliskisinin temsilleri arasındaki iliski: Ebeveynlerin kisilerarasi semalarinin ve baglanma modellerinin etkisi [Relationship among beliefs dealing with self, interpersonal schemas and representation of attachment relationship at preschool children: Impact of parent's interpersonal schemas and their attachment models]*. (Unpublished doctoral dissertation). Hacettepe University, Ankara, Turkey.
- Uluc, S., & Oktem, F. (2009). Okul oncesi cocuklarda guvenli yer senaryolarinin degerlendirilmesi [Assessment of secure base script in preschool children]. *Turk Psikoloji Dergisi/Turkish Journal of Psychology*, 24(63), 69-83.
- Walker, S., Irving, K., & Berthelsen, D. (2002). Gender influences on preschool children's social problem-solving strategies. *The Journal of Genetic Psychology*, 163(2), 197-209.
- Yilmaz, E. (2012). *60-72 aylık cocukların duyguları anlama becerilerinin sosyal problem cozme becerilerine etkisinin incelenmesi. [Studying effect of emotion recognition skills of 5-6 year old children on their social problem solving skills]* (Unpublished master thesis). Selcuk University, Konya, Turkey.
- Yilmaz, E. (2016). *48-72 aylık cocuklara yönelik sosyal problem cozme becerileri olceginin gelistirilmesi [The development of Social Problem Solving Skills Scale for 48-72 month old children]* (Unpublished doctoral dissertation). Marmara University, Istanbul, Turkey.
- Yilmaz, E., & Tepeli, K. (2013). 60-72 aylık cocukların sosyal problem cozme becerilerinin duyguları anlama becerileri acisindan incelenmesi [Examination of social problem solving skills of 60-72 months old children in terms of their emotion understanding skills]. *Turkiye Sosyal Arastirmalar Dergisi/Turkish Journal of Social Research*, 17(2), 117-130.

# Music Teacher Candidates in Piano Education: An Evaluation of The Causes of Their Success

Zafer Tural

## Introduction

Success and failure are the result of every learning process in the academic field. This situation at the end of the learning process also has a psychological effect. To be happy in the case of success or to be disappointed in the case of failure is often the first reaction to our psychological point of view. Individuals are happy about success, carry personal self-confidence, concentrate on more work, exhibit less anti-social behavior and are more optimistic about achieving work at the beginning; In case of failure, frustration, depression, sadness etc. emotional reactions and more pessimistic (Bandura, 1982; act., Guven, et al., 2011; Ozguven, 1974). The student may affect the success and failure can come from two potential sources. They can be effective in individual success or in the environment. The factors in the individual achievement category can include personal training background, learned ability, personal experience, personality and personal interest. The factors in the environmental impact category may include a person's academic anxiety, working / anxiety anxiety, family anxiety, technology / facility anxiety, time and cost concern, and social / personal relationship anxiety (Chen, 1998). When we examine the success of piano education, many factors need to be examined. First of all, teacher's pedagogical approach is important. When examined in terms of the instructor, communication with the student, motivation to motivate, teaching techniques are important; In terms of the student, interest, curiosity and related motivation should be provided sufficiently. The aim of the student is to achieve a goal in a planned, programmed and disciplined way throughout the education process.

The effort of the students in achieving success is a more important source of motivation than all other factors. As in all branches of education, the most important factor that provides success in music education is to strive. In particular, the effort of the students in working in the instrument training and piano education process in particular and in achieving performance-based success is becoming more important. With these characteristics, it is possible to say that music education is an area where students will need more effort for success (Kurtuldu, 2010).

Particularly it is possible to observe the positive effects of music teacher trainees in their professional life when they complete their education with a successful process in piano education. Because it is expected that the students will be able to use the piano efficiently in the future. Music teacher candidates, piano education both during their own education and in the future when they become music teachers will be able to play the piano skills required for music teaching (Cevik-Kilic, 2018). Therefore, music teacher, especially in the school in the extracurricular activities of the choir can accompany the piano; In the lessons, the piano with the solfege of the song to teach and the accompaniment of the piano with the song will contribute to professional success. It is important to determine, examine and evaluate the reasons of the success and failure situation questioned by the candidates of the music teacher.

## Method

### Research Model

In this study, qualitative research method was used and descriptive model was chosen as the screening method. In this study, semi-structured interview technique was used. The semi-structured interview is a bit more flexible than the structured interview. In this technique, the researcher prepares the interview protocol which includes the questions that he / she intends to ask in advance. On the other hand, depending on the flow of the interview, the researcher can influence the flow of the interview

with different side or sub-questions, and enable the person to open and elaborate his / her responses. The researcher may not ask these questions if the person has answered the questions of other questions during the interview. The semi-structured interview technique gives a more appropriate technical appearance in educational science researches due to the specific level of standardization and flexibility. This interview can be seen in qualitative research (Ekiz, 2003 act, Cetin, 2012).

### **Working Group**

The study group of the study is 12 randomly selected students in the fourth year of the Department of Music Education at COMU Faculty of Education, Fine Arts Education Department in 2016-2017 academic year. 6 of the 12 students were female and 6 were male. The study group was determined according to purposive sampling method which is widely used in qualitative research. In the purposeful sampling, the most appropriate individuals associated with the problem state are included in the study (Sahin et al., 2013).

### **Data Collection Tools**

One-on-one interviews were conducted with prospective teachers. Interview with open-ended questions; written, oral and audio recordings were created. The interview form was used as a data collection tool. Interview with each student took 20 minutes on average. The questionnaire, which was used as data collection tool, was developed by Guven et al. (2010) and prepared by taking pilot opinions and expert opinions. Therefore, the validity of the questions asked in the research is acceptable. During the interview with the teacher candidates, the following questions were asked:

1. What do you think are the factors affecting the success of the piano lesson? 1.
2. What do you think are the solution suggestions if you fail in the piano lesson? 2.
3. "How do you think the perspective of the piano lesson and the attitudes towards the course have a relationship with the piano lessons? 3.

### **Data Analysis**

At the end of the interviews with prospective teachers in the study group, the data were analyzed by descriptive method. The descriptive analysis method allows the data to be presented by taking the research questions into consideration (Yildirim & Simsek, 2008). In the descriptive analysis, direct quotations are frequently given to reflect the thoughts of the interviewed individuals. Placing direct quotations is important for validity (Wolcott, 1990). The names of the students who participated in the research were not explained on the basis of confidentiality. Only encodings based on sex are given. 6 Male and 6 female students were listed according to their gender and numbered in quotations.

When analyzing the data, "Conversation Coding Keys" were determined for each teacher candidate. The data recorded according to these encodings were processed separately in electronic environment. The data were analyzed descriptively by creating individual frequencies for each question. The answers to the questions are indicated in tables as frequencies. The data obtained from the study group are indicated by table frequencies.

The responses of the study group were coded by the researcher and the reliability study was conducted. For the data collected in the research (in content analysis), in the calculation of reliability;  $\text{Reliability} = \text{Consensus} / (\text{Consensus} + \text{Disagreement})$  Miles and Huberman (1994) were formed using the reliability formula. The reliability of the study was 86.1%. The fact that reliability is above 70% indicates that the study is reliable.

### **Findings and Comment**

The findings obtained from the study group data that were asked in the study were reviewed and interpreted in this section.

#### **Lar What do you think are the factors that influence the success of the piano lesson?**

The answers given by the teacher candidates and the frequency distributions are given in Table 1 above.

## Music Teacher Candidates in Piano Education

<b>Teacher Candidates ' Thoughts</b>	<b>f</b>
Efficient work	10
Regular and disciplined work	8
Communication with piano teacher	8
Motivation status	7
Piano and lesson liking	6
Note anxiety	4
Physically insufficient work rooms	4
Piano lesson	4
Level playback	3
Insufficiency of pianos	3
Other courses other than piano lessons take time to work	3
Having his own piano	3
Environmental impacts	3
Piano education at an early age	2
Being forced to work out of school due to financial situation difficulties	2
In the piano class, the teacher forced the students to do the works they didn't like	2
Deficiencies in basic music knowledge	2
Ability to set goals	2
Criticism of the course teacher	1
Work by following a specific method	1
Low self esteem	1
<b>Sum Of Opinions</b>	<b>79</b>

In Table 1, the majority of the students who answered the question emphasized the impact of efficient work on success. Many also think that regular, disciplined work and communication with the teacher will have a significant impact on success. Half of the participants said that loving the piano instrument would also contribute to success. Some of the candidate teachers stated that they did not work long enough because they did not have their own piano (E2., B5., E8.(see).

Another one student explained the reason for the drop in motivation as "when my lesson teacher criticizes me, my interest and interest towards the lesson decreases" (E11). Another remarkable answer stated in the table is "my piano teacher gives me the works I don't like for work" (7). In addition, two students stated that they were working part-time jobs after classes due to lack of material (B7., E12). They stated that this situation caused failure in piano lessons and other courses (B3., E11.). Some of the students believe that environmental conditions negatively affect success. A student on this subject: "My friends come to study room while working on the piano. All concentration is impaired" (E12). Some of the students think that the objectives related to the course should be determined correctly (E1., B4.). The three students who participated in the study reported that "other courses other than piano lessons affect the success of the piano because of the high density" (B5., E8., B10.). A student who participated in the study stated that working according to a specific method would be more beneficial and would have a positive effect on success (E1). Another student stated that he could not succeed in the piano lesson, shaking the self-confidence and causing the failure (B7).

**The teacher candidates "In case of failure in piano course, what are the solution suggestions?"  
The Answer To The Question.**

The answers given by the teacher candidates to the above question are given in Table 2 with frequency distributions.

**Table 2 Solution suggestions for the failure of the Working Group in piano lessons**

<b>Teachers' Candidates Suggestions</b>	<b>f</b>
Change of pedagogical approaches	8
Change of working methods used in education	6
Change of course teacher	5
Regular and scheduled work	5
Be patient	3
Ask the teacher for help	3
Increasing the number of piano in the extracurricular section	3
To devote more time to technical studies in piano education	2
Increasing motivation against piano lessons	1
Lesson teachers spend more effort in class	1
<b>Sum Of Opinions</b>	<b>37</b>

According to the answers given above in Table 2, the most recommended solution for teacher candidates is the desire to change the pedagogical approach of piano teachers. Eight students have expressed their opinion in this direction. The students who applied for their opinions stated that they had stolen studies and works above the piano playing levels (E1., B3., B4., B5., E8., B9., B10., E12.). Parallel to this issue, half of the teacher candidates who participated in the interview expressed their opinions on the change of working methods (E1.B, 3., B4., B9., B10., E12.). Another remarkable point is that the piano teacher is demanding change. It was determined that the five students who demanded teachers were the students who gave opinions in the first two items in Table 2 (B3., B4., B9., B10., E12.). Five participants stated that they could achieve success by working regularly and programmatically (E2., E6., B7.E, 8., E11.). Three participants used the phrase E be patient to reach the success goal while playing the piano sab (E2., B9., E12.). Some students who participated in the study stated that in case of failure in piano education process, teacher support should be applied (E2., B7., E11.). Three participants emphasize the inadequacy of piano numbers in the department for extracurricular piano studies (B3., B5., B10.). Two students stated that technical studies should be given importance in order to achieve success in piano education (B5., B7.). One student who participated in the research stated that the motivation for success goal in the piano education process (E8) and the other student stated that the instructor should make more efforts in the education process (B5).

### **The Teacher Candidates' "What do you think is the point of view of piano lesson and the attitude towards the lesson have to do with the success of the piano lesson?" The Answer To The Question**

The last question was asked to the pre-service teachers who were selected as study group and their responses were arranged according to frequencies in Table 3.

**Table 3. Responses of the study group to the piano lesson and how the attitudes towards the course are related to the piano lesson success**

<b>Teachers' Candidates Suggestions</b>	<b>f</b>
If you like to play piano, learning motivation will have a positive effect on success.	9
If he doesn't like to play the piano, his motivation is low and he / she will have a negative impact on success.	5
Communication with the course teacher has a positive or negative impact on our success.	3
Being prejudiced against the piano lesson adversely affects success.	2
Studies and works that we do not like melody reduce our desire to work and affect our success negatively.	1
<b>Total of Opinions</b>	<b>20</b>

As stated in Table 3, the majority of prospective teacher candidates stated that "if the student likes to play the piano, he / she has high motivation and affects the success positively motiv (E2., B3., B4., B5., E6., E8., B9. , E11., E12.). Some of the teacher candidates responded that E if the student does not like to play the piano, his / her motivation is low and this affects the success negatively motiv (E1., E2., B4., B5., E11.). In addition, three prospective teachers who participated in the interview thought that loving the teacher of course would contribute to the success by increasing the interest in the course. on the other hand, they expressed that the interest in the course would decrease and trigger failure (B7., B10., E12.). Two prospective teachers stated that being prejudiced against the lesson meant neglecting the importance of the piano lesson and negating the awareness. A student who participated in the interview stated that he was unsuccessful in his musical work, reducing his desire to study and his work (B3.).

### **Discussion, Conclusion and Suggestions**

Piano education in the music education program during the undergraduate education, regular, disciplined and correct methods and techniques are one of the courses that should be studied using. It is important that pre-service teachers are able to stabilize their piano education for four years. When the answers of the students were examined, it was mentioned that the importance of productive study as one of the most important elements of success in piano education was mentioned. They also emphasized that there should be a planned and disciplined process to work efficiently. Agile-Sword (2016), piano lessons in the solution of the problems encountered in the solution, this course will be effective in solving problems in the long-term reading. This result supports research. In a study, students emphasize the importance of loving piano work, working regularly and loving piano instructors. One of the most important elements in a good piano performance is to work planned and correct (Nurcan., Cevik-Kilic., & Canbey, 2015).

In a study conducted by Fink (1999), it is emphasized that piano education should be carried out in a planned and programmed manner, and that students should be given a positive attitude and approach towards the lesson and the instrument. These findings are in parallel with the study.

The most important issue of teacher candidates is the love of the piano. The majority of the teacher candidates participating in this answer believe that motivation against the lesson will increase by loving the piano and achievement of the goal of success. According to behavioral approaches, the individual's internal attitudes are an effective factor in motivation. In other words, rather than external stimulants such as punishment and reinforcement, the individual's behaviors determine the individual's beliefs, expectations, goals, values (Woolfolk, 1998 act, Karatas, 2011). As mentioned in the theory, it is thought that the situations that the person internalizes depending on love, curiosity and expectation will contribute to success.

Another point we obtain from the answers of the teacher candidates is student-teacher communication. During the course of the piano education, it was emphasized that the students who had communication problems with their teachers would decrease their interest in the course and affect the success negatively. When the findings of Pehlivan (2005) are examined, it is aimed to examine the characteristics of teachers, such as bil having knowledge of the field, using language in a clear and understandable way, being democratic, creating appropriate sentences, creating physical environments that support communication ili based on classroom communication; pre-service teachers stated that such characteristics as smiling, having empathy skills, love, using body language effectively, being tolerant, being willing to communicate, loving the profession, respecting the student and using the language effectively. Therefore, personality plays an important role in music education (Cevik, 2011a). Based on the five-factor personality model, Cevik (2011a) found that Turkish music teacher candidates are creative, social, tolerant, and high communication enthusiasm. These results support the research findings. In a study conducted using Holland's theory, music teacher candidates focus on artistic and social personality characteristics such as being smiling, tolerant and having high communication skills (Cevik et al., 2013). In Cevik-Kilic (2017b) research, it is stated that the personalities of music teachers are responsible, ambitious, careful, diligent, planned and disciplined.

As it is seen in this study, it is a subject that we should be sensitive about teacher-student communication especially in teacher training institutions. With the right communication, it is possible



to ensure that students are more interested in the lesson. Correct communication skills suggest that students will contribute positively to the achievement of students (Cevik, 2011b). According to the research conducted by Cevik-Kilic (2017c), it is emphasized that teachers should be able to empathize most and student-teacher communication should be in a healthy way. This finding is in parallel with the research.

As stated in the findings, it is observed that internal and external (environmental) factors have a positive or negative effect on the success of the piano lesson when we evaluate the answers of the prospective teachers. Although most of the pre-service teachers know the necessary steps to achieve success in piano lessons, it has been observed that success is disrupted due to factors such as the intensity of other courses in the music education program, lack of communication, lack of physical space, and dislike of methods and techniques applied by the teacher for the course. In the study conducted by Cevik-Kilic (2017a), it is emphasized that the materials used in the piano teaching process play a major role in the success of students.

As a result, Music Education Programs continue their education and training activities within the Faculty of Education. Many schools of education do not have a building suitable for Music Teaching Programs. There should be special buildings for these programs, the number of individual study rooms should be sufficient and they should be equipped with qualified instruments. It is thought that if physical space is improved, it will contribute positively to student success. In addition, it is important that the group consisting of teachers who enter the piano course in music programs, considers the lesson planning and the methods and criteria to be applied jointly. The committee should also evaluate the situation of unsuccessful students, except for decisions on the piano lesson. In this context, the factors affecting the success of students should be evaluated and their problems should be analyzed.

## References

- Chen, H. (1998). Factors Affect Student Success And Failure, EMC598. Arizona State University, USA.
- Cevik, B., Perkmen, S., Alkan, M., Shelley, M. (2013). Who Should Study Music Education? A Vocational Personality Approach, *Music Education Research*, 15 (3), 341-356, September 2013. DOI: 10.1080/14613808.2013.788140.
- Cetin, O. (2012). <http://oguzcetin.gen.tr/nitel-bir-arastirma-teknigi-gorusme.html>
- Cevik, B. (2011a). Personality self-perceptions of Turkish music pre-service teachers in relation to departmental satisfaction. *International Journal of Music Education*, 29, 212-228. doi:10.1177/0255761410396282.
- Cevik, D. B. (2011b). Muzik Ogretmeni Adaylarının İletişim Becerileri, *Gazi Üniversitesi Gazi Eğitim Fakültesi Dergisi*, *Cilt 31, Sayı 1, 1-13*.
- Cevik-Kilic, D. B. (2016). Students' and instructors' Opinions about piano instruction, *Educational Research and Reviews*, 11 (10), 966-974.
- Cevik-Kilic, D. B., Baltacılar-Bayoglu, T. O., & Canbey, E. G. (2017a). The Occupational Expectations of Undergraduate Students in the Conservatory Piano Majors, *International Education Studies*, 11(1), 1-10.
- Cevik Kilic, D. B. (2017b). Türkiye'deki Muzik Öğretmenlerinin Kişilikleri ve İş Tatminleri, *Kastamonu Üniversitesi Kastamonu Eğitim Dergisi*, 25 (1), 435-454.
- Cevik-Kilic, D. B. (2017c). Research on Education. (Eds.:Hasan Arslan/Carmen Sonia Duse/Mehmet Ali İcbay, Part B: "Teaching and Learning: "Music Pedagogy Undergraduate Students' Expectations from Piano Instruction", (pp. 248-253). ISBN 978-83-948896-3-0 E-BWN - Bialystok, Poland 2017
- Cevik-Kilic, D. B. (2018). An Investigation of Music Teacher Candidates' Performance Anxiety Levels in Piano Examinations, *Journal of Education and Learning*, 7(1), 299-308.
- Durak, I. (1998). İletmelerde Çalışan İnsanlardan Daha Fazla Yararlanma Aracı Olarak Motivasyon Süreci ve Bir Uygulama. Yüksek Lisans Tezi, Denizli.
- Fink, S. (1999). Mastering piano technique: A guide for students, teachers and performers. (4.baskı). USA: Amadeus Press, LLC.

- Guven, E., Cevik, D. B. (2011). Piyano Dersinde Basari Durumunu Etkileyen Nedenler: Muzik Ogretmeni Adaylarinin Degerlendirmeleri, 1st Uluslararası Egitim Programlari ve Ogretim Kongresi, 05-08 Ekim, Eskisehir.
- Kurtuldu, M.K. (2010). Piyano Egitiminde Basarisizlik Nedenlerine Yonelik Ogrenci Goruslerinin degerlendirilmesi, *Kastamonu Egitim Dergisi*, 18(3), 917-930.
- Karatas, H. (2011). Universite Ogrencilerinin Epistemolojik Inanclari ve Ogrenme Yaklasimlari, Problem Cozme Becerilerinin Akademik Motivasyonu Yordama Gucu. Doktora Tezi, Yildiz Teknik Universitesi Sosyal Bilimler Enstitusu, Istanbul.
- Miles, M. B. & Huberman, A. M. (1994). *Qualitative data analysis: an expanded sourcebook*. (2nd Edition). Calif. : SAGE Publications.
- Nurcan, O., Cevik-Kilic, D. B., & Canbey, G. E. (2015). Outlooks of Conservatory Piano Majors Toward the Use of Turkish Composers' Works in Applied Piano Lessons, *Journal of Educational and Instructional Studies in the World*, 5(2), 65-77.
- Pehlivan, B. K. (2005). Ogretmen adaylarinin Iletisim Becerisi Algilari Uzerine Bir Calisma. *Mugla Universitesi, Egitim Bilimleri Bolumu, Ilkogretim-Online*, 4(2), 17-23.
- Sahin, C., Kartal, O.Y. (2013). Sinif Ogretmeni Adaylarinin Sinif Ogretmeni yetistirme Programi Hakkindaki Gorusleri. *Usak Universitesi Sosyal Bilimler Dergisi*, 6(1), 169.
- Tural, Z. (2011). COMU Egitim Fakultesi Ogrencilerinin Ogretmenlik Meslegine Iliskin Motivasyonlarini Etkileyen Etkenler. (Yayimlanmamis Yuksek Lisans Donem Projesi). Ahmet Yesevi Universitesi, Ankara.
- Wolcott, H. (1990). On seeking and rejecting validity in qualitative research, in E. Eisner and A. Peshkin (eds) *Qualitative Inquiry in Education: The Continuing Debate*, pp. 121-52. New York: Teachers College Press.
- Yildirim, A. ve Simsek, H. (2008). *Sosyal bilimlerde nitel arastirma yontemleri*. Ankara: Seckin Yayınevi.



# Examination of High School Students' Thoughts about STEM before a STEM Study

Canan Nakiboglu

## 1. Introduction

The great developments in science and technology over the last years have caused the expectation of the countries from their citizens to change. The 21st-century skills consist of a set of abilities that the countries are aiming to bring their students to compete with the world. These skills are the learning skills such as critical thinking, creative thinking, collaborating, communicating; literacy skills such as information literacy, media literacy, technology literacy; life skill such as social skills, leadership, productivity, flexibility, initiative. For this reason, the countries have begun to change their curriculums to improve these skills of individuals. One of these changes is STEM education. STEM education is an integrated educational approach to the fields of Science, Technology, Engineering, and Mathematics. In recent years, many activities related to STEM education have been developed and applied to the students in our country too. As in many countries in Turkey, it is seen that done many studies on STEM education in recent years (Elmalı & Balkan Kiyici, 2017; Hacıoğlu, Yamak, Kavak, 2016; Herdem & Unal, 2018; Yildirim, 2016; Yildirim & Selvi, 2016). Tezsezen (2011) cited that it was important for today's people to be aware of STEM and the relationships between STEM areas because literacy in any area needed awareness of that area.

There are studies that examined the attitudes of students towards STEM and their opinions after STEM activities (Gokbayrak & Karisan, 2017), and the STEM awareness (Aslan-Tutak, Akaygun, Tezsezen, 2017; Buyruk and Korkmaz, 2016; Cevik, 2017). Tyler-Wood, Knezek, and Christensen (2010) were developed two instruments for assessing interest in STEM content and careers while applying their instruments to middle school teachers and their students. Buyruk and Korkmaz (2016) have also developed a credible scale to determine the STEM awareness levels. When carrying out such studies, it is important to assess the students' awareness or the STEM knowledge levels of the students or participants at the beginning of the study. Very few studies show that the awareness of the participants is examined at the beginning of the study. Duygu (2018) was examined the effect of STEM education on university students' scientific process skills and STEM awareness situations in simulation-based inquiry learning environment. At the end of the study, it was found that STEM education had a positive influence on the development of scientific process skills and on STEM awareness.

In their study, Aslan-Tutak et al., (2017), they introduced a Collaboratively Learning to Teach STEM (CLT-STEM) module which was prepared in the light of STEM education approach and also they discussed the influence of CLT-STEM module on pre-service teachers' STEM conceptions. They focused on to find out the differences between participating senior chemistry and mathematics pre-service teachers' definition of STEM before and after attending CLT-STEM and participating pre-service teachers' views on STEM education methods. In another study, Gokbayrak and Karisan (2017) investigated students' views about the science, technology, engineering, mathematics (STEM) after application. It was found that the students had positive views on the STEM activities and they were keen to develop themselves in these fields. Ciftci (2018) was examined the influence of STEM activities on the understanding of the relationship among STEM disciplines, STEM professions, and scientific creativity levels. At the end of the study, it was concluded that activities developed based on the STEM approach were effective in improving the relationship between the STEM disciplines and the scientific creativity of students. It was also determined that STEM activities had a positive effect to improve their knowledge and skills about STEM professions and their views on STEM professions.

In some research is cited that the STEM literacy of the societies can be increased firstly providing them aware of STEM by giving students opportunities to deal with daily life problems, to produce creative solutions, to work in collaborative environments, to use technology effectively, to make real designs (Tezsezen, 2011). For this reason, it is important to make the teaching applications in which

the students have real life problems related to the STEM. On the other hand, while STEM activities are conducted during the studies, students are not informed about STEM in generally. On the other hand, it is important for the students to realize what the STEM is and the STEM fields. This study includes some part of the research that was carried out before an STEM study began to take place. It was aimed to find out what the 11th grade students knew about the STEM and whether they had previously participated in any STEM-related activities before in this study. Based on these aim of the study, the research problems identified of the study are:

1. What do students know about STEM before the STEM study?
2. What are the students' experiences with STEM before the STEM study?
3. What do students think about STEM before STEM study?

## 2. Method

**2.1 Study model:** In this study, *descriptive research* was used. A descriptive research study determines and describes the wat things are. This study is a *cross-sectional descriptive* study and cross-sectional survey involves the collection of the data from selected individuals in a single time period (Gay and Airasian, 2000).

**2.2 Sample of the study:** The sample of the study consists of 88 11th grade students attending three different classes of an Anatolian high school with a high academic success in Balikesir.

**2.3 Data Collection Tool:** A questionnaire consisting of 2 main and 4 sub-questions was prepared by the researcher of the study. The sub-questions relate to explanations of basic questions. The questionnaire was first examined by the teacher of the practice school where the study was conducted. This teacher also attended STEM basic and advanced level in service training. The questionnaire was finalized considering chemistry teacher's opinion. The questionnaire was applied by the teacher of the classes before the STEM study started.

**2.4 Data analysis:** The data were analyzed with content analysis method by the researcher of the study. To obtain intra-judge reliability of the analysis, the researcher analyzed the data for the second time 1 month after the first analysis (Gay and Airasion, 2000, p.175). The data were presented by tabulation and the quotations from the students' views were also included during the presentation. Students are coded as S1, S2 ....., S88.

## 3. Findings

In the first question, the students were asked whether they heard about STEM education before STEM study. The findings of students' awareness of STEM before STEM study are presented in Table 1.

**Table 1.** Students' awareness of STEM before STEM study

Students' answers	f	%
Yes	51	58
No	37	42
<b>Total</b>	88	100

When Table 1 is examined, it is seen that while 58% of the students heard STEM, 42% of them did not hear STEM before STEM study. In the second question, they were asked to explain what happened if they had already heard of STEM. The findings of the descriptions about STEM of those who heard the STEM before are presented in Table 2. The responses related to the descriptions of the students who heard STEM were collected under eight themes which were "science and math", "education", "science, mathematics and engineering", "science, technology, mathematics, and engineering", "learning", "coding / software related", "science and technology", and "creativity".

**Table 2.** Descriptions of students about STEM who have heard STEM

Themes	Expression examples	f	%	
<b>Science and math Education</b>	Studies on science and mathematics	12	12	14
	Practical education	10	12	14
<b>Science, mathematics and engineering</b>	Study for development of education	1		
	Education system	1		
	A combination of science, mathematics and engineering	9	9	10
	A combination of science, technology, mathematics and engineering.	6	9	10
<b>Science, technology, mathematics, and engineering</b>	It is an educational system aiming to establish an interdisciplinary connection (science, mathematics, and engineering) in problem solving.	1		
	Science, Mathematics, Technology, Engineering	2		
	STEM science, technology, engineering and mathematics learning	1	8	9
	To hinder rote-learning	3		
	Memorable system in science education	4		
<b>Learning</b>	Do work on coding.	2	2	2
<b>Coding / Software related</b>	Something about physics, chemistry, biology and technology	1	1	1
<b>Science and technology</b>	STEM is a combination of science and creativity.	1	1	1
<b>Creativity</b>				

When Table 2 is examined, it is understood that that most of the students are able to relate STEM to science and mathematics, but the only 10% of the students were able to add both technology and engineering to the description of STEM as well. On the other hand, it is recognized that only 1 student has made a correct definition.

It can also be seen from Table 2 that a small number of students can associate STEM with learning. Two of the students mentioned an expression under the code of learning.

“STEM science, technology, engineering and mathematics learning in relationship with each other is carried out in the area as a whole (S63)”

“A more experimental and memorable system, especially in science education (S22)”

In the study, students were asked to predict that they did not hear STEM. The explanations of the students who have not heard STEM before are shown in Table 3. The explanations related to the prediction of the students who did hear STEM were collected under three themes which were “technology”, “science”, and “system”. In addition, it is seen that 11% of students are meaningless and 6% do not make any predictions. The meaningless predictions made by the students were also analyzed and the findings are presented in Table 4.

**Table 3.** Predictions of students about STEM who have not heard STEM

Themes	Expression examples	f	%
<b>Technology</b>	It could be an issue of technology and science.	6	9 10
	Something like a mix of science and technology	1	
	Technological project for engineering	1	
	It can be related to writing Software	1	
<b>Science</b>	It is related to science.	3	7 8
	Making the theoretical knowledge available in science practical	1	
	Adaptation of science and mathematics to daily life and giving skills training in this field.	1	
	Could be something about chemistry	1	
<b>System</b>	Biology, chemistry and physics under the same roof	1	4 5
	Education system / It is related to education	2	
	Evaluation / information system	1	
	It can be a multiple system that combines several courses.	1	
<b>Meaningless predictions</b>		10	10 11
<b>No prediction</b>		5	5 6

**Table 4.** Meaningless predictions of students about STEM who have not heard STEM

Meaningless predictions	f	%
It could be a disease.	1	10 11
It can be an abbreviation of an organization / community	3	
It can be related to faculties / universities	2	
It could be something like reproach	2	
It can be information form	1	
It can be a book.	1	

In the fourth question, the students were asked whether they had participated in a STEM study previously. The findings related to this issue are presented in Table 5. When Table 5 is examined that only %4 of the students have participated in a STEM-related study before. After then, the students were asked to write what kind of study they participated in. The findings of this questions are presented in Table 6.

**Table 5.** Students' participation in STEM studies

Student answers	f	%
Participants in a STEM study	4	4
Non-participants in a STEM study	78	89
No response	6	7
Total	88	100

**Table 6.** STEM studies of students before application

Students	Attended STEM studies
S16	Robotics competitions, STEM Club, TUBITAK Biology Project, Science Fairs
S17	Robotic TUBITAK Project Activities, TUBITAK Biology Project, Robotics Studies
S31	TUBITAK Project Competition, Robotic TUBITAK Project Activities, Robotic Activities
S49	Joining to the School Club.

Finally, the students participating in STEM study were asked to write down their thoughts on this subject. Only S16 and S17 coded students answered this question. These students' descriptions are as follows.

“I think it is very important for the development of personality and intelligence. We contribute to the future and technology of the country and the world, and it makes me feel happy. Now we are living in a period where the technology is good and the producer is strong (S16)”

“I joined these projects because I was interested in the fields. The use of engineering in mathematics and science made me feel successful, and in the future I decided to focus on these fields in my professional life (S17)”

#### 4. Discussion

In this study, it was investigated that students' awareness before participating a STEM study. At the end of the study it was concluded that while 58% of the students heard STEM education, almost half of them did not hear. When the answers of these students who are aware of STEM are examined, it can be said that only 8% of the students have a relation with science, mathematics, technology, and engineering areas correctly. It is seen that some of the students think that this situation is related to only coding / software that. In both media and science fairs, mostly under the title of STEM studies, coding and robotic-related activities are included. This leads to a perception that STEM studies are only related to coding and robotics.

The results of this study show that the students do not have much knowledge about what STEM is, what the purpose of it is, and especially they do not have the correct information. This situation can be due to the fact that the students have not been given more information about what they were done to them despite they have joined the applications related to STEM. Teachers either think that students know the purpose of these activities or they do not give much importance for providing to the students the knowledge about STEM. On the other hand, the success of a teaching approach such as STEM is highly related to the conscious and motivated student.

Therefore, knowledge about what the STEM is and what the purpose of such a teaching is and what the tasks that fall in them are should be provided to students before the practices. In this way, STEM education can be carried out consciously and it can be reached the desired success of STEM. Teachers should be also warned and informed about this matter in their teacher training.

This study was supported by the project number 2017/079. Author thanks to Balikesir University BAP unit.

#### 5. References

- Aslan-Tutak, F., Akaygun, S., & Tezsezen, S. (2017). Isbirlikli FeTeMM (Fen, Teknoloji, Muhendislik, Matematik) egitimi uygulaması: kimya ve matematik ogretmen adaylarinin FeTeMM farkindaliklarinin incelenmesi. *Hacettepe Universitesi Egitim Fakultesi Dergisi [H. U. Journal of Education]* 32(4): 794-816.
- Buyruk, B., & Korkmaz, O. (2016). STEM Awareness Scale (SAS): Validity and Reliability Study. Part B: *Turk Fen Egitimi Dergisi*. 13 (2), 61-76.
- Cevik, M. (2017). A study of STEM Awareness Scale development for high school teachers. *International Journal of Human Sciences*. 14(3), 2436-2452.
- Ciftci, M. (2018). Gelistirilen STEM etkinliklerinin ortaokul ogrencilerinin bilimsel yaraticilik duzeylerine, stem disiplinlerini anlamalarına ve stemmesleklerini fark etmelerine etkisi. Recep Tayyip Erdogan Universitesi, Fen Bilimleri Enstitusu. Unpublished master thesis.
- Duygu, E. (2018). Simulasyon tabanlı sorgulayıcı öğrenme ortamında fetemm eğitiminin bilimsel süreç becerileri ve fetemm farkındalıklarına etkisi. Kirikkale Üniversitesi Fen Bilimleri Enstitüsü, Kirikkale. Unpublished master thesis.
- Elmalı, S., & Balkan Kiyici, F. (2017). Türkiye’de Yayınlanmış FeTeMM Eğitimi İle İlgili Çalışmaların İncelenmesi. *Sakarya University Journal of Education*, 7(3), 684-696. Doi: 10.19126/suje.322791.



- Gay L. R., & Airasian P. (2000). *Educational research: competencies for analysis and application*. Prentice-Hall, New Jersey.
- Gokbayrak, S., & Karisan, D. (2017). Altinci sinif ogrencilerinin FeteMM temelli etkinlikler hakkında goruslerinin incelenmesi. *Alan Egitimi Arastirmalari Dergisi (ALEG)*, 3(1), 25-39.
- Hacioglu, Y., Yamak, H., & Kavak, N. (2016). Pre-service science teachers' cognitive structures regarding science, technology, engineering, mathematics (STEM) and science education. *Journal of Turkish Science Education*, pp:88-102.
- Herdem, K., & Unal, I. (2018). STEM Egitimi Uzerine Yapilan Calismalarin Analizi: Bir Meta-Sentez Calismasi. *Educational Research in International Context • Uluslararası Egitim Arastirmalari*, 145-163.
- Yildirim, B., & Selvi, M. (2016). Examination of the effects of STEM education integrated as a part of science, technology, society and environment courses. *Journal of Human Sciences*, 13(3), 3684-3695.
- Yildirim, B. (2016). An analyses and meta-synthesis of research on STEM education, *Journal of Education and Practice*, 7(34), 23-33.
- Tezsezen, S. (2017). An investigation of preservice teachers' STEM awareness through definitions and relationships of STEM areas. Institute for Graduate Studies in Science and Engineering, Bogazici University. Unpublished master thesis.
- Tyler-Wood, T., Knezek, G., & Christensen, R. (2010). Instruments for Assessing Interest in STEM Content and Careers. *Jl. of Technology and Teacher Education*. 18(2), 341-363.

# Examining The Relationship between Levels of Teaching Practices Preschool Teachers Use to Promote Children's Self-Regulated Learning and Their Self-Regulation Levels

Rengin Zembat, Hilal Yilmaz

## 1. Introduction

Nowadays, students' understanding their own learning process, as well as teachers' understanding students' learning efforts and trying to help them learn, has become an important aspect of learning in teaching and learning contexts (Alci & Altun, 2007). In today's education system, the most essential aim is to train individuals who are aware of their own learning and skills, construct knowledge and engage in learning processes actively (Aydin & Demir, 2014). Research studies on educational sciences have shown that self-regulated learning and strategies in which individuals control their own learning processes affect their academic achievement (Chika E, Obodo & Okafor, 2015; Dent & Koenka, 2015; Ocak & Yamac, 2013; Wolters & Hussain, 2015; Zee & de Bree, 2016).

Risemberg and Zimmerman (1992) defined self-regulation as goal setting, developing strategies to reach these goals and monitoring effectiveness of these strategies. According to Kauffman (2004), self-regulation is efforts of a learner to control and manage complex learning activities.

Self-regulated learning can be defined as each kind of process, technique, method and strategy which an individual can use on the way of self-knowledge and self-learning. In other words, it is related to determining one's own aims and motivating himself/herself cognitively to reach these aims. In addition, studies have shown that teaching self-regulation is important not only for formal education but also for life-long learning (Ciltas, 2011).

Individuals trained in the environment where their self-regulatory abilities are promoted and developed will be one step ahead in life. It is very important for individuals to develop their knowledge and skills day by day and to acquire knowledge which takes themselves further. At this point, teachers have a lot of responsibilities for creating effective learning environments. Teachers should promote students' self-regulatory abilities by developing their own self-regulation. They should provide opportunities for students to engage in self-regulated learning. They should provide situations which will motivate the students for life-long learning. They should allow students to set their own goals and standards. They should help students to make reflective self-assessment. Not only should they evaluate students quantitatively but they should also give students feedbacks about quality of their works (Ambreen, Haqdad & Saleem, 2016; Uredi & Uredi, 2007).

The teachers who fulfill these responsibilities contribute and affect their students' development of self-regulated learning (Perels, Merget-Kullmann, Wende, Schmitz & Buchbinder 2009; Perkan Zeki & Sonyel, 2014; Perry, Hutchinson & Thauberger, 2008; Peters-Burton, Cleary & Kitsantas, 2015; Postholm, 2011). Besides, studies have shown that teachers' classroom practices have influenced students' development of self-regulation (Fuhs, Farran & Nesbitt, 2013; Hur, Buettner & Jeon, 2015; Muñoz & Santa Cruz, 2016; Peeters et al., 2014; Sungur & Gungoren, 2009; Uyar, Ates & Yildirim, 2012).

Therefore, since preschool teachers have essential roles to develop children's self-regulation; it is important to determine levels of teaching practices they use to promote children's self-regulated learning and their self-regulation levels. Existing studies have addressed development of children's self-regulation rather than roles of teachers on it in early childhood period (Erturk, 2013; Erturk Kara & Gonen, 2015; Findik Tanribuyurdu; 2012; Gunduz, 2015; Keles, 2014; Sahin, 2015; Tilbe, 2015). However, self-regulated learning is firstly taught by teachers. Therefore, research conducted on development of children's self-regulation without examining preschool teachers' self-regulation levels would be incomplete to create fully effective educational contexts in early childhood period.

On the other hand, reviewing the existing research has shown that teachers' epistemological beliefs and views (Dogan, 2014; Kaleci, 2012; Khonamri & Salimi, 2010; Kuzu, 2015; Sen, 2015), their self-efficacy beliefs and views (Cetingoz, 2012; Dilekli, 2015; Ekinci Vural & Hamurcu, 2008), their perceptions on teaching (Dereli, 2013; Mertoglu, 2011) and their reflective thinking skills (Dalgic, 2011) are related to teaching practices they use to promote children's self-regulated learning. In Turkey, there is a lack of research on levels of teaching practices preschool teachers use to promote children's self-regulated learning and their self-regulation levels.

In this regard, the present study aims to examine the relationship between levels of teaching practices preschool teachers use to promote children's self-regulated learning and their self-regulation levels. Meanwhile, another aim is to investigate whether levels of teaching practices preschool teachers use to promote children's self-regulated learning and their self-regulation levels differ in terms of their age, educational levels and professional seniority.

## 2. Method

The research, carried out with survey method, is conducted in preschool education institutions in Cekmekoy, Kadikoy, Sancaktepe and Uskudar districts on the Asia side and Eyup, Kagithane and Kucukcekmece districts on the Europe side of Istanbul. Participants of the present study consist of 465 preschool teachers who work at public and private preschool education institutions during 2015-2016 academic year. "Personal Information Form" developed by researchers, "Self-Regulation Scale" adapted into Turkish by Aydin, Ozer, Keskin and Yel (2014) and "Scale of Assessing Preschool Teachers' Practices to Promote Self-Regulated Learning" developed by Adagideli, Sarac and Ader (2015) are administered as data collection tools in the study.

## 3. Results

The relationship between levels of teaching practices preschool teachers use to promote children's self-regulated learning and their self-regulation levels is presented in Table 3.1.

**Table 3.1. Results of Pearson Product-Moment Correlation Coefficient: The relationship between levels of teaching practices preschool teachers use to promote children's self-regulated learning and their self-regulation levels.**

Variables	N	r	p
Self-regulation levels	465	,597	,000
Teaching practice levels			

As shown in Table 3.1, there is a significant positive medium relationship between levels of teaching practices preschool teachers use to promote children's self-regulated learning and their self-regulation levels ( $p < .001$ ,  $r = 0.597$ ). Therefore, it could be asserted that levels of teaching practices preschool teachers use increase as their self-regulation levels increase.

While the mean self-regulation scale score of preschool teachers is 190,86 ( $SD = 25,03$ ); preschool teachers have average scores of 109.63 ( $SD = 13.38$ ), 69.33 ( $SD = 13.51$ ) and 10.15 ( $SD = 2.03$ ) from self-reinforcement, self-monitoring and self-evaluation subscales of the scale, respectively.

While the mean scale of assessing preschool teachers' practices to promote self-regulated learning score of preschool teachers is 39.33 ( $SD = 13.64$ ); preschool teachers have average scores of 8.31 ( $SD = 4.49$ ), 13.18 ( $SD = 3.43$ ), 6.52 ( $SD = 3.68$ ), 5.08 ( $SD = 2.27$ ) and 6.22 ( $SD = 2.06$ ) from emotional and motivational regulation, metacognitive regulation during task, metacognitive knowledge of task and strategy, metacognitive regulation after task and metacognitive knowledge of person subscales of the scale, respectively.

Findings indicating the effect of age on preschool teachers' self-regulation levels are presented in Table 3.2.

**Table 3.2. Results of One-Way Analysis of Variance (ANOVA): The effects of age on preschool teachers' self-regulation levels**

	Sum of Squares	df	Mean Square	F	p
Between Groups	22544,939	2	11272,469		
Within Groups	268288,8	462	580,712	19,411	,000***
<b>Total</b>	<b>290833,7</b>	<b>464</b>			

\*\*\* $p < .001$

As seen in Table 3.2, preschool teachers' self-regulation levels differ as function of their age ( $F=19,411$ ,  $p < .001$ ). In order to determine where the difference occurs between groups, the post hoc analysis is used. Since the homogeneity of variances assumption is not met, the Tamhane test is used. The Tamhane post hoc test reveals that self-regulation levels of preschool teachers who are at least 31 years old are significantly higher compared to levels of preschool teachers ranged between 21-25 and 26-30. Moreover, findings show that self-regulation levels of preschool teachers ranged between 26-30 are significantly higher than levels of preschool teachers ranged between 21-25.

Findings indicating the effect of preschool teachers' education levels on their self-regulation levels are presented in Table 3.3.

**Table 3.3. Results of Kruskal Wallis-H Test: The effects of preschool teachers' education levels on their self-regulation levels**

Score	Groups	N	Mean Square	$\chi^2$	df	p
The Self-regulation Scale	High School Degree	87	165,61	114,452	3	,000
	Associate Degree	138	163,57			
	Bachelor's Degree	220	295,22			
	Master's Degree	20	320,80			
	Total	<b>465</b>				

\*\*\* $p < .001$

As shown in Table 3.3, Kruskal-Wallis H test shows that there is a significant difference in preschool teachers' self-regulation levels between four groups ( $\chi^2=114,452$ ,  $p < .001$ ). In order to determine where the difference occurs between groups, Mann Whitney-U Test is used. Findings show that self-regulation levels of preschool teachers having master's degree are significantly higher compared to levels of the ones having high school and associative degree. Moreover, self-regulation levels of preschool teachers having bachelor's degree are significantly higher than levels of the ones having high school and associative degree. Nonetheless, the two groups having bachelor's degree and master's degree do not differ significantly.

Findings indicating the effect of professional seniority on preschool teachers' self-regulation levels are presented in Table 3.4.

**Table 3.4. Results of One-Way Analysis of Variance (ANOVA): The effects of professional seniority on preschool teachers' self-regulation levels**

	Sum of Squares	df	Mean Square	F	p
Between Groups	6616,945	2	3308,472		
Within Groups	284216,8	462	615,188	5,378	,005**
<b>Total</b>	<b>290833,7</b>	<b>464</b>			

\*\* $p < .01$

As seen in Table 3.4, preschool teachers' self-regulation levels differ as function of their professional seniority ( $F=5,378$ ,  $p < .01$ ). In order to determine where the difference occurs, the groups are compared using the post hoc test. Since the homogeneity of variances assumption is not met, the Tamhane test is used. The Tamhane post hoc test reveals that self-regulation levels of preschool teachers with at least

11 years of professional experience are significantly higher compared to levels of the ones with at most 5 years of professional experience and 6-10 years of professional experience.

Findings indicating the effect of age on levels of teaching practices preschool teachers use to promote children's self-regulated learning are presented in Table 3.5.

**Table 3.5. Results of One-Way Analysis of Variance (ANOVA): The effects of age on levels of teaching practices preschool teachers use to promote children's self-regulated learning**

	Sum of Squares	df	Mean Square	F	p
Between Groups	6296,846	2	3148,423		
Within Groups	80081,468	462	173,337	18,164	,000***
Total	86378,314	464			

\*\*\* $p < .001$

As seen in Table 3.5, levels of teaching practices preschool teachers use to promote children's self-regulated learning differ as function of their age ( $F=18,164$ ,  $p < .001$ ). In order to determine where the difference occurs, the groups are compared using the post hoc test. Since the homogeneity of variances assumption is not met, the Tamhane test is used. The Tamhane post hoc test reveals that the levels of preschool teachers who are at least 31 years old are significantly higher than levels of the ones ranged between 21-25 and 26-30.

Findings indicating the effect of educational levels of preschool teachers on levels of teaching practices they use to promote children's self-regulated learning are presented in Table 3.6.

**Table 3.6. Results of Kruskal Wallis-H Test: The effects of educational levels of preschool teachers on levels of teaching practices they use to promote children's self-regulated learning**

Score	Groups	N	Mean Square	$\chi^2$	df	p
The Teaching Practices Scale	High School	87	180,54	68,740	3	,000***
	Degree					
	Associate Degree	138	180,67			
	Bachelor's Degree	220	278,00			
	Master's Degree	20	327,27			
	Total	465				

\*\*\* $p < .001$

As shown in Table 3.6, Kruskal-Wallis H test shows that there is a significant difference in levels of teaching practices preschool teachers use between four groups ( $\chi^2=68,740$ ;  $p < .001$ ). In order to determine where the difference occurs between groups, Mann Whitney-U Test is used. Findings show that teaching practices levels of preschool teachers having master's degree are significantly higher compared to levels of the ones having high school and associative degree and bachelor's degree. Moreover, teaching practices levels of preschool teachers having bachelor's degree are significantly higher than levels of the ones having high school and associative degree.

Findings indicating the effect of professional seniority on levels of teaching practices preschool teachers use to promote children's self-regulated learning are presented in Table 3.7.

**Table 3.7. Results of One-Way Analysis of Variance (ANOVA): The effects of professional seniority on levels of teaching practices preschool teachers use**

	Sum of Squares	df	Mean Square	F	p
Between Groups	1342,850	2	671,425		
Within Groups	85035,464	462	184,059	3,648	,027*
<b>Total</b>	<b>86378,314</b>	<b>464</b>			

\* $p < .05$

As seen in Table 3.7, levels of teaching practice preschool teachers use to promote children's self-regulated learning differ as function of their professional seniority ( $F=3,648$ ,  $p<.05$ ). In order to determine where the difference occurs, the groups are compared using the post hoc test. Since the homogeneity of variances assumption is not met, the Tamhane test is used. The Tamhane post hoc test reveals that teaching practice levels of preschool teachers with at least 11 years of professional experience are significantly higher compared to levels of the ones with at most 5 years of professional experience and 6-10 years of professional experience.

#### 4. Discussion and Conclusion

Findings of this study show that there is a significant positive medium relationship between levels of teaching practices preschool teachers use and their self-regulation levels. In parallel to the present study, the research on primary school teachers has shown that there was a significant positive relationship between teachers' teaching practices to promote students' thinking skills and their self-efficacy towards teaching thinking skills (Dilekli, 2015). As teachers' self-efficacy scores increased, activities they have applied to promote thinking skills increased.

According to findings of the present study, preschool teachers have medium self-regulation levels. On the contrary, Celik, Ercoskun and Kose (2014) concluded that prospective teachers had satisfactory self-regulation levels. Moreover, research conducted by Guler (2015) found that prospective teachers' self-regulation levels were high. Previous studies on self-regulation have conducted with teachers other than preschool teachers and prospective teachers. Therefore, results of the present study would be enlightening for further studies with preschool teachers.

Results of this study show that levels of teaching practices preschool teachers use to promote children's self-regulated learning are at medium level. Dilekli's study (2015) indicated that levels of teachers' conducting activities to teach thinking skills were high. The study on primary and secondary school teachers conducted by Spruce and Bol (2015) revealed that teachers had positive beliefs about self-regulated teaching practices in the classroom. Dignath-van Ewijk and van der Werf (2012) found that although teachers had positive beliefs to promote students' self-regulated learning; they had difficulties about how they promoted students' self-regulated learning.

Results ascertain that preschool teachers' self-regulation levels differ according to their age. Average self-regulation scores of preschool teachers who are at least 31 years old are significantly higher compared to their colleagues'. Therefore, preschool teachers' self-regulation levels increase as their age increases. There are existing researches supporting this result of the present study (Zimmerman, 2002; Whitebread & Basilio, 2012). These studies also have confirmed that age is an important factor in development of self-regulatory abilities. Mental development reaching maturity with age affected individuals' cognitive abilities such as self-control, self-evaluation, self-observation, goal setting, planning and analyzing (Zimmerman, 2002).

Results show that preschool teachers' self-regulation levels differ according to their educational levels. Average scores of preschool teachers having bachelor's and master's degree are significantly higher compared to their colleagues'. Findings of teachers' educational levels in the present study support results of the study on professional development and self-regulatory abilities (Butler, Lauscher, Jarvis-Selinger & Beckingham, 2004). In that study, teachers' educational levels also affected their self-regulatory abilities.

Results also show that preschool teachers' self-regulation levels differ according to their professional seniority. Average scores of preschool teachers with at least 11 years of professional experience are significantly higher compared to their colleagues'. Results of professional seniority support the study on teachers' professional seniority and self-regulatory abilities (Butler et al., 2004). In that study, professional seniority also affected self-regulatory abilities.

Results reveal that levels of teaching practices preschool teachers use to promote children's self-regulated learning differ according to their age. Average scores of preschool teachers who are at least 31 years old are significantly higher than their colleagues'. In a previous study, it was also found that teachers' metacognitive abilities increased with age (Zimmerman, 2002). Teachers use various types teaching practices with age. Therefore, their teaching practice levels increase.

Results indicate that levels of teaching practices preschool teachers use to promote children's self-regulated learning differ according to their educational levels. Average scores of preschool teachers having bachelor's and master's degree are significantly higher compared to their colleagues'. As teachers' education levels increase, levels of teaching practices they use increase. On the contrary, Celik (2012) found that mathematics teachers' tendency to promote self-regulated learning did not differ according to their educational levels. The present study is enlightening for theory and practice of early childhood education since it reveals that levels of teaching practices preschool teachers use differ according to their educational levels. Considering this result, opportunities should be provided to increase preschool teachers' educational levels.

Results also show that levels of teaching practices preschool teachers use differ according to their professional seniority. Average scores of preschool teachers with at least 11 years of professional experience are significantly higher compared to their colleagues'. Dilekli (2015) found that more experienced teachers conducted more classroom activities to promote thinking skills. Teachers were more competent to use strategies in their teaching practices such as considering children's individual needs, providing opportunities for children to make their own decisions and promoting positive peer relationships among children as they became more experienced in the profession (Ilgan, 2013; Bain, 2004).

Based on the result of the present study that there is a relationship between levels of teaching practices preschool teachers use to promote children's self-regulated learning and their self-regulation levels, not only should they be encouraged to engage in activities that foster their self-regulation but they should also be provided with opportunities to do so. The result also indicates that educational levels of preschool teachers affect both levels of teaching practices they use to promote children's self-regulated learning and their own self-regulation levels. Therefore, their educational levels should be raised. In addition, programs aimed to promote preschool teachers' self-regulation levels can be considered as a future step. Moreover, replication studies with different participants can be conducted to compare results.

## 5. References

- Adagideli, F. H., Sarac, S., & Ader, E. (2015). Assessing preschool teachers' practices to promote self-regulated learning. *International Electronic Journal of Elementary Education*, 7, 423-439.
- Alci, B., & Altun, S. (2007). Lise ogrencilerinin matematik dersine yonelik oz duzenleme ve bilis ustü becerileri, cinsiyete, sinifa ve alanlara gore farklilasmakta midir? *Cukurova Universitesi Sosyal Bilimler Enstitüsü Dergisi*, 16(1), 33-44.
- Ambreen, M., Haqdad, A., & Saleem, W. A. (2016). Fostering self-regulated learning through distance education: A case study of M. Phil secondary teacher education program of Allama Iqbal Open University. *Turkish Online Journal of Distance Education*, 17(3), 120-135.
- Aydin, S., & Demir, T. (2014). *Oz-duzenlemeli ogrenme*. Ankara: Pegem Akademi.
- Aydin, S., Keskin, M., & Yel, M. (2014). Oz-duzenleme olcegi'nin turkce uyarlamasi: gecerlik ve guvenirlik calismasi. *Turkish Journal of Education*, 3, 28-32.
- Bain, K. (2004). *What the best college teachers do*. Cambridge, Massachusetts: Harvard University Press.
- Butler, D. L., Lauscher, H. N., Jarvis-Selinger, S., & Beckingham, B. (2004). Collaboration and self-regulation in teachers' professional development. *Teaching and Teacher Education*, 20(5), 435-455.

- Chika E., N., Obodo, A. C., & Okafor, G. (2015). Effect of self-regulated learning approach on junior secondary school students' achievement in basic science. *Journal of Education of Practice*, 6(5), 45-52.
- Celik Ercoskun, N., & Kose, E. (2014). İlkogretim bolumu ogretmen adaylarinin oz duzenleme ve problem cozme becerilerinin incelenmesi. *International Online Journal of Educational Sciences*, 6(2), 413-428.
- Celik, N. (2012). *Matematik ogretmen adaylarinin ve ogretmenlerinin oz duzenleme becerilerinin ve oz yeterlik algilarinin incelenmesi* (Yayimlanmamis Yuksek Lisans Tezi). Ataturk Universitesi, Egitim Bilimleri Enstitusu, Erzurum.
- Cetingoz, D. (2012). Okul oncesi egitimi ogretmen adaylarinin yaratıcı drama yontemini kullanmaya yönelik ozyeterlikleri. *Hacettepe Universitesi Egitim Fakultesi Dergisi*, 42, 131-142.
- Ciltas, A. (2011). Egitimde oz-duzenleme ogretiminin onemi uzerine bir calisma. *Mehmet Akif Ersoy Universitesi Sosyal Bilimler Enstitusu Dergisi*, 3(5), 1-11.
- Dalgic, G. (2011). *Okul yoneticilerinin yansitici dusunme beceri ve uygulamalarinin incelenmesi: Istanbul ve Kopenhag ornegi* (Yayimlanmamis Doktora Tezi). Marmara Universitesi, Egitim Bilimleri Enstitusu, Istanbul.
- Dent, A. L., & Koenka, A. C. (2015). The relation between self-regulated learning and academic achievement across childhood and adolescence: A meta-analysis. *Educational Psychology Review*, 28(110), 1-50.
- Dignath-van Ewijk, C., & van der Werf, G. (2012). What teachers think about self-regulated learning: Investigating teacher beliefs and teacher behavior of enhancing students' self-regulation. *Education Research International*, 2012, 1-10.
- Dilekli, Y. (2015). *Ogretmenlerin dusunmeyi ogretmeye yönelik yaptıkları sınıf içi uygulamalar, ozyeterlik duzeyleri ve ogretim stilleri arasındaki iliski*. (Yayimlanmamis Doktora Tezi). Balikesir Universitesi, Sosyal Bilimler Enstitusu, Balikesir.
- Dogan, M. F., & Sahin-Taskin, C. (2014). *Ilkokul ogrencilerinin oz-duzenlemeli ogrenme becerilerinin gelistirilmesi: sınıf ogretmenlerinin gorusleri*. VI. Uluslararası Egitim Arastirmaları Kongresi: 5 Haziran 2014, Ankara: Bildiriler Kitabı (s. 590-599).
- Dogan, O. K. (2014). *Meslege yeni baslayan fen ogretmenlerinin pedagojik ve epistemolojik inançları ve sınıf içi uygulamaları: Boylamsal durum calismasi* (Doktora Tezi). Marmara Universitesi, Egitim Bilimleri Enstitusu, Istanbul.
- Ekinci Vural D., & Hamurcu, H. (2008). Okul oncesi ogretmen adaylarinin fen ogretimi dersine yönelik oz-yeterlik inançları ve gorusleri. *Ilkogretim Online*, 7(2), 456-467.
- Erturk Kara, H. G., & Gonen, M. (2015). Examination of children's self-regulation skill in terms of different variables. *Journal of Theory and Practice in Education*, 11(4), 1224-1239.
- Erturk, H. G. (2013). *Ogretmen çocuk etkilesiminin niteligi ile çocukların oz-duzenleme becerisi arasındaki iliskinin incelenmesi* (Doktora tezi). Hacettepe Universitesi, Egitim Bilimleri Enstitusu, Ankara.
- Findik Tanribuyurdu, E. (2012). *Okul oncesi oz duzenleme olcegi gecerlik ve guvenirlik calismasi* (Yayimlanmamis yuksek lisans tezi). Hacettepe Universitesi, Sosyal Bilimler Enstitusu, Ankara.
- Fuhs, M. W., Farran, D. C., & Nesbitt, K. T. (2013). Preschool classroom processes as predictors of children's cognitive self-regulation skills development. *School Psychology Quarterly*, 28(4), 347-359.
- Guler, M. (2015). *Ogretmen adaylarinin oz-duzenleme becerilerinin; duygusal zekâları, epistemolojik inançları ve bazı degiskenler acısından incelenmesi* (Yayınlanmamis doktora tezi). Necmettin Erbakan Universitesi, Egitim Bilimleri Enstitusu, Konya.
- Gunduz, G. (2015). *Self-regulation in Turkish preschoolers: Relations with family context and socio-emotional competence* (Yayimlanmamis yuksek lisans tezi). Koc Universitesi, Sosyal Bilimler Enstitusu, Istanbul.
- Hur, E., Buettner, C. K., & Jeon, L. (2015). The association between teachers' child-centered beliefs and children's academic achievement: The indirect effect of children's behavioral self-regulation. *Child Youth Care Forum*, 44, 309-325.



- Ilgan, A. (2013). Ogretmenler icin etkili mesleki gelism faaliyetleri. *Usak Universitesi Sosyal Bilimler Dergisi, Ozel Sayi*, 41-56.
- Kaleci, F. (2012). *Matematik ogretmen adaylarinin epistemolojik inanclari ile ogrenme ve ogretim stilleri arasindaki iliski* (Yayimlanmamis yuksek lisans tezi). Necmettin Erbakan Universitesi, Egitim Bilimleri Enstitusu, Konya.
- Kauffman, D. F. (2004). Self-regulated learning in web-based environments: instructional tools designed to facilitate cognitive strategy use, metacognitive processing and motivational beliefs. *Journal Of Educational Computing Research*, 30, 139.
- Keles, S. (2014). *Kulturel-tarihsel kuram baglaminda hazirlanan egitim programinin 48-60 aylık cocukların öz-duzenleme gelismine uzerine etkisinin incelenmesi* (Yayimlanmamis doktora tezi). Gazi Universitesi, Egitim Bilimleri Enstitusu, Ankara.
- Khonamri, F., & Salimi, M. (2010). The interplay between EFL high school teachers' beliefs and their instructional practices regarding reading strategies. *Novitas-ROYAL (Research on Youth and Language)*, 4(1), 96-107.
- Kuzu, K. (2015). *Okul oncesi ogretmenlerinin degerler egitimi hakkındaki gorusleri ve bu goruslerin sinif icin uygulamalara yansimasi* (Yayimlanmamis yuksek lisans tezi). Uludag Universitesi, Egitim Bilimleri Enstitusu, Bursa.
- Muñoz L., & Santa Cruz, J. (2016). The preschool classroom as a context for cognitive development: Type of teacher feedback and children's metacognitive control. *Electronic Journal of Research in Educational Psychology*, 14(1), 23-44.
- Ocak, G., & Yamac, A. (2013). Ilkogretim besinci sinif ogrencilerinin öz-duzenleyici öğrenme stratejileri, motivasyonel inanclari, matematige yönelik tutum ve basarilari arasindaki iliskinin incelenmesi. *Kuram ve Uygulamada Egitim Bilimleri*, 13(1), 369-387.
- Peeters, J., De Backer, F., Reina, V. R., Kindekens, A., Buffel, T., & Lombaerts, K. (2014). The role of teachers' self-regulatory capacities in the implementation of self-regulated learning practices. *5th World Conference on Educational Sciences-WCES 2013 Procedia-Social and Behavioral Sciences*, 116: 1963-1970.
- Perels, F., Merget-Kullmann, M., Wende, M., Schmitz, B., & Buchbinder, C. (2009). Improving self-regulated learning of preschool children: Evaluation of training for kindergarten teachers. *British Journal of Educational Psychology*, 79, 311-327.
- Perkan Zeki, C., & Sonyel, B. (2014). Pre-service teachers' perceptions of the student centered learning approach through a metaphoric perspective. *Hacettepe Universitesi Egitim Fakultesi Dergisi [Hacettepe University Journal of Education]*, 29(1), 211-225.
- Perry, N. E., Hutchinson, L., & Thauberger, C. (2008). Talking about teaching self-regulated learning: Scaffolding student teachers' development and use of practices that promote self-regulated learning. *International Journal of Educational Research*, 47, 97-108.
- Peters-Burton, E. E., Cleary, T. J., & Kitsantas, A. (2015). *The development of computational thinking in the context of science and engineering practices: a self-regulated learning approach*. 12th International Conference on Cognition and Exploratory Learning in Digital Age (CELDA 2015), pp. 257-261.
- Postholm, M. B. (2011). Self-regulated learning in teaching: Students' experiences. *Teachers and Teaching: Theory and Practice*, 17(3), 365-382.
- Risemberg, R., & Zimmerman, B. J. (1992). Self-regulated learning in gifted student. *Roeper Review*, 15, 98.
- Spruce R., & Bol L. (2015). Teachers beliefs, knowledge, and practice of self-regulated learning. *Metacognition Learning*, 10, 245-277.
- Sungur, S., & Gungoren, S. (2009). The role of classroom environment perceptions in self-regulated learning and science achievement. *Elementary Education Online*, 8(3), 883-900.
- Sahin, G. (2015). *Okul oncesi cocukların yurutucu islevlerinin ve duyu düzenleme becerilerinin baglanma oruntuleri acisindan incelenmesi* (Yayimlanmamis doktora tezi). Selcuk Universitesi, Sosyal Bilimler Enstitusu, Konya.

## Examining The Relationship between Levels

- Sen, O. F. (2015). *Fen bilgisi ogretmenlerinin ogretime ve ogrenmeye yonelik inanclari ve sinif ici uygulamalari* (Yayimlanmamis yuksek lisans tezi). Kirikkale Universitesi, Fen Bilimleri Enstitusu, Kirikkale.
- Tilbe, E. (2015). *Identifying the relationship between behavior regulation, parenting attitude, and behavior problems in preschoolers* (Yayimlanmamis yuksek lisans tezi). Bahcesehir Universitesi, Sosyal Bilimler Enstitusu, Istanbul.
- Uyar, Y., Ates, S., & Yildirim, K. (2012). Ogretmen adaylarinin okudugunu anlama surecinde kullandiklari oz duzenlemeye dayali ogrenme becerileri. *Mustafa Kemal Universitesi Sosyal Bilimler Enstitusu Dergisi*, 9(18), 227-247.
- Uredi, I., & Uredi, L. (2007). Ogrencilerin oz-duzenleme becerilerini gelistiren ogrenme ortamının olusturulmasi. *Mersin Universitesi Egitim Fakultesi Dergisi*, 1(2), 250-260.
- Whitebread, D., & Basilio, M. (2012). The emergence and early development of self-regulation in young children. *Profesorado: Journal of Curriculum and Teacher Education*, 16(1), 15-34.
- Wolters, C. A., & Hussain, M. (2015). Investigating grit and its relation with college students' self-regulated learning and academic achievement. *Metacognition Learning*, 10, 293-311.
- Zee, M., & de Bree, E. (2016). Students' self-regulation and achievement in basic reading and math skills: The role of student-teacher relationships in middle childhood. *European Journal of Developmental Psychology*, 10, 1-16.
- Zimmerman, B. J. (2002). Becoming a self-regulated learner: an overview. *Theory Into Practice*, 41(2), 614-62



# **The Stakeholders' Perspectives for Universities' Social Responsibilities: The Case of Canakkale, Turkey**

Ozgur Batur, Hasan Arslan

## **1. Introduction**

Universities are organizations that perform a key role within contemporary societies by educating large proportions of the population and generating knowledge (Perkmanna et al., 2013, p. 423). Universities are morally accountable to society in general (Cooper, 2005), through scholarship, research and leadership in the residential areas which they function. This moral accountability includes the duty of universities to be engaged in the mental process of societal transformation as well as the performance of the university's natural function of instruction and research (OECD Observer, 2006). Depending on the findings of a research that is conducted by Mizikaci (2012) in six European countries with 66 participants, universities all around Europe are still preserving their traditional visions and missions, and are not likely to be prepared for the demands of the knowledge society. Turkish universities also face similar problems and cannot form worthy practices. It is difficult to observe that there are good relations between the universities, industry and the society. Alas, an active cooperation could not be worked despite the efforts and steps that are taken (Gunay, 2011, p. 115). Drucker (1996) emphasized that economic factors ruled the administrative and managerial aspects during the last 40-50 years, but in the forthcoming 20-30 years, societal factors would gain importance.

### **1.1. Social Responsibility**

Promulgation of the Magna Charta of European universities, signed by 430 rectors in 1988 in Bologna, can be regarded as the overture of academic, sociological reflection on the future of the university (Hrubos, 2011, p. 347). For the first time as a body institutional leaders, representatives of the academic community, proclaimed the fundamental principles to be observed in relation to the function of the university, which can be seen as a starting point of the changes in universities including the rise of social acts by means of social responsibility (SR) phenomenon. SR is broadly defined as pro-social behavior (Bierhoff, 2002) that seeks to advance and promote community among the broad spectrum of society (Starrett, 1996). Colby et al. (2003) maintain that SR is based on two 'inseparable responsibilities', that are moral and civic. According to Colby et al. (2000), "a morally and civically responsible individual recognizes himself or herself as a member of a larger social fabric and therefore considers social problems to be at least partly his or her own; such an individual is willing to see the moral and civic dimensions of issues, to make and justify informed moral and civic judgments and to take action when appropriate", whom can be called as a Socially Responsible Citizen (Colby, Ehrlich, Beaumont & Stephens, 2000; Tosado 2011).

### **1.2. Universities' Social Responsibilities**

According to Karima, Oshima, and Yamamoto (2006), universities have social responsibilities, called as 'University Social Responsibility (USR)'. Universities are organizations that perform a key role within contemporary societies by educating large proportions of the population and generating knowledge (Perkmanna et al., 2013, p. 423) and the general goal of higher education (HE) has been, for many centuries, to mold individuals with attitudes and skills that lead to intellectual activity and upright moral and ethical character (AACU, 2008). As they are the top educational institutions in all countries, in the way to educate for SR, which is imparting "learning that emphasizes what students can do with their knowledge and that involves students, individually and collectively, in analyzing and working to solve significant problems in the larger world" (Schneider, 2005, p. 127), universities should be able to teach and foster the human capacities necessary to achieve moral and civic responsibility (As cited in Tosado, 2011, p. 4).

### 1.3. The Stakeholders

Are actors-organizations, agencies, clubs, groups or individuals-who may gain or lose from an organization's activities (Ackoff 1981; Allen 1988) -with an interest in the organization's performance. Freeman's definition of stakeholder (1984, p. 46) is very broad (As Cited in Benneworth and Jongbloed, 2009), 'any group or individual who can affect or is affected by the achievement of the organization's objectives'. Shawyun et al. (2012) state that managing USR strategically within the institution is an imperative of the future sustainability of the institution for meeting the needs of stakeholders and societal needs. The identification of the most important stakeholder groups that the expectations are to be fulfilled, on the other hand, is not straightforward (Benneworth & Jongbloed, 2010). The Stakeholder theory classifies stakeholders according to their relative importance or salience (Mitchell et al. 1997), and allows us to explore the impact of differential salience on the influence over universities. Table 1 below states the categories of the stakeholders that have influence on universities.

**Table 1. Stakeholder Categories and Constitutive Groups\***

<b>Stakeholder category</b>	<b>Constitutive groups, communities</b>
<b>Governing entities</b>	State & federal government; governing board; board of trustees, buffer organizations; sponsoring religious organizations
<b>Administration</b>	President (vice-chancellor); senior administrators
<b>Employees</b>	Faculty; administrative staff; support staff
<b>Clienteles</b>	Students; parents/spouses; tuition reimbursement providers; service partners; employers; field placement sites
<b>Suppliers</b>	Secondary education providers; alumni; other colleges and universities; food purveyors; insurance companies; utilities; contracted services
<b>Competitors</b>	Direct: private and public providers of post-secondary education Potential: distance providers; new ventures Substitutes: employer-sponsored training programs
<b>Donors</b>	Individuals (includes trustees, friends, parents, alumni, employees, industry, research councils, foundations)
<b>Communities</b>	Neighbors; school systems; social services; chambers of commerce; special interest groups
<b>Government regulators</b>	Ministry of Education; buffer organizations; state & federal financial aid agencies; research councils; federal research support; tax authorities; social security; Patent Office
<b>Non-governmental regulators</b>	Foundations; institutional and programmatic accrediting bodies; professional associations; church sponsors
<b>Financial intermediaries</b>	Banks; fund managers; analysts
<b>Joint venture partners</b>	Alliances & consortia; corporate co-sponsors of research and educational services

\*Derived from Benneworth and Jongbloed (2010) after Burrows (1999)

University success has always depended on capacity to secure resources to achieve their core missions (Ernste, 2007). An important element of this is the creation of 'useful knowledge' embedded in people, technologies, books and networks (Spaapen et al. 2007; Marginson 2007). The value of that

knowledge is defined by universities' key stakeholders through terms such as its quality, utility and relevance that can have a considerable influence on universities.

## 2. Method

A qualitative methodology is conducted in this research as it helps “to produce a thick description (Geertz, 1973) and in-depth understanding of the phenomenon of interest, the cultural or lived experience of people in natural setting” (As cited in Magilvy, 2003, p. 123). According to Merriam and Associates (2002, p. 7), case study is the recommended research method (Scott, 2007, p. 117) for examining “contemporary events” when the “relevant behaviors cannot be manipulated” and the evidence can be gathered through interviews, documents, artifacts and observation. According to Tosado (2011), many scholars state that HE promotes development of social responsibility (Colby et al., 2003; Patton, 1987). Therefore, “the insights and approaches” of universities that educate for social responsibility “are portfolios of best practices from which” other institutions may learn (Colby et al., 2003, p. 10). Tosado (2011, p. 129) also underlines that, this is why research about SR in HE has been mostly conducted using a case study methodology (Colby et al., 2003). Depending on this reason, standardized open-ended eight interview questions are designed for this research to gather relevant data from the stakeholders to examine their perceptions of USR in Canakkale, Turkey in 2015. Interviews took 20-50 min., which are conducted through an interview protocol. The data are analyzed by Nvivo 10 qualitative data analysis software. Content analysis technique is used in this research. *Governing Entities, Administration, Employees, Clienteles, Non-governmental Regulators* that are stated in Table 1 above are regarded as the leading stakeholder groups in this research and the study group is designed to involve representatives from each group. The study group is stated in Table 2 below.

**Table 2. Demographic Information of the Study Group**

Pseudonym	Gender	Age	Position	Affiliation
A1	Male	51	Prof. Dr./Administrator	Faculty of Education
A2	Female	40	Assoc. Prof. Dr./Administrator	Faculty of Education
A3	Male	47	Assoc. Prof. Dr./Administrator	Faculty of Education
A4	Female	41	Assoc. Prof. Dr./Administrator	Faculty of Education
A5	Male	43	Assist. Prof. Dr./Faculty member	Faculty of Education
A6	Male	49	Assist. Prof. Dr./Faculty member	Faculty of Education
A7	Male	43	Assist. Prof. Dr./Faculty member	Faculty of Education
C1	Female	67	Administrator/Housewife	Turkish Women's Association
C2	Male	50	Accountant/Ret. Army officer	The Ata. Thought Association
C3	Male	48	Administrator/Ret. Worker	Orphans' Association
C4	Male	52	Administrator /Prof. Dr.	Contemporary Life Association
C5	Male	42	Administrator/Primary Teacher, MA	Level Educational Syndicate
C6	Male	52	Administrator/Prof. Dr.	Educational Syndicate
C7	Male	47	Administrator/Primary Level Teacher	Educational Syndicate
L1	Female	34	Public Relations Employee	Municipality
L2	Female	44	Culture and Social Issues Employee	Dept. Municipality/ City Council Sec.
L3	Male	64	Administrator/Ret. Primary Level Teacher	City Council
L4	Female	44	Manager/Ret. Lecturer	Municipality
S1	Male	21	Info. and Comm. Tech. student	Faculty of Education
S2	Male	21	English Language and Teaching student	Faculty of Education

S3	Female	23	Mathematics student	Faculty of Arts and Science
S4	Female	23	Guidance and Counseling student	Faculty of Education

Each participant is given a pseudonym identifier to protect their anonymity and maintain confidentiality. The Academician participants are referred as 'A', Community Service Organization members are referred as 'C', Local Authority employees are referred as 'L' and undergraduate student participants are referred as 'S'.

### 3. Findings

**The first interview question** is the determination of social responsibility phenomenon from the perspective of the participants. Amongst the seven academician participants, four of them identified the social responsibility term as "individuals' positive actions that are taken for the benefit of the society that they live in". It is considered by the academicians that the efficient range of these positive actions must be from the micro level to macro level. Participant A2 underlines the situation as; "Social responsibility is realizing the social problems and then forming an active power to get over these problems with a personal commitment." Another participant (A6) backs up the personal commitment idea as; "When you use the social responsibility term, I see the total obligations of an individual that must be accomplished personally." The data related to the first interview question are reflected in Table 3 below.

**Table 3. Identification of Social Responsibility**

Theme	Category	Codes	Participants
Identifying the meaning of SR from a personal viewpoint	_Individual act	_personal steps taken	_A2,A4,A5,A6,A7,C1,C3,C4,C7,L4,S1,S2,S4
	_Group act		_A1,A3,C2,L1,L2,L3,S3
	_Governmental duty	_actions within groups	_C1,C5,C6
		_primary concern of the state	

Depending on the responses given to the first interview question it is possible to say that twelve (A2, A4, A5, A6, A7, C3, C4, C7, L4, S1, S2, S4= 55 %) participants of the study group out of 22 believe that SR is an *individual act*, seven participants (A1, A3, C2, L1, L2, L3, S3= 32 %) regard SR as a *group act*, and three participants (C1, C5, C6= 13%) believe that SR must be a *governmental duty*, that is done for the benefit of the society with efforts to create a better engaged community.

**The second interview question** aims to clarify the third mission of the universities, which is also called USR, from the perception of the participants. There are participants (A2, A4, A5, S2) that think USR applications need to be '*beyond education and research activities*', so that education and research activities are also regarded as USR in the field of literature (Geryk, 2011). Participant A4, who has administrative duty at the Institute of Educational Sciences, emphasizes the situation as;

What is the main duty of universities?... education and research, graduating the required work power... Yes, that is true. Besides, if we approach the idea with a holistic point of view, universities must create applications that are directly for the benefit of the society. We cannot make a clear divide actually, so that education and research also can be regarded as a social responsibility act that is to fulfill.

**Table 4. Identification of Universities' Social Responsibility**

Theme	Category	Codes	Participants
Identifying the meaning of USR from personal viewpoint	_Employee based	_academicians and personnel	_A3, C3
	_Duty based	_beyond education and research activities'	_A2, A4, A5, S2
	_Domain based	_words without education'	_C1, C2, C5, L2

Participants are asked to identify USR, but they approached the subject with a holistic point of view and their descriptions contained criticism with two sides (internal and external), creation of different ideas (e.g. free access to HEIs facilities), many expectations (e.g. active cooperation, dissemination of current knowledge), important roles (e.g. leadership, unifier). The participants believe that USR both as an idea and an action, must involve several aspects as, that taking action from an 'employee based', 'duty based' and 'domain based' perspective into a holistic point of view, in order to be more creative and to fulfill the engagement duty with the society. There were participants (C1, C2, C5, L2) that did not use any word related to education or research whom are CSO and LA members. Participant L2 stated that HEIs have holistic duties, so that they involve a rich blend of domains, which assigns them an important position towards the demands of the city and the society by saying; "The city and the university must be a single unit."

**The third interview question** examines what participants' know about current USR applications. There are academician participants (A3, A4, A7) who regard *seminars, workshops, conferences* as USR applications. Participant A3 emphasizes the applications of the Faculty of Education as;

Our faculty has a special act that we go to the villages and rural areas every year in September and June, to arrange educational seminars for the people living there. These can be regarded as social responsibility projects that are conducted at an institutional level.

**Table 5. Current USR Applications**

Theme	Category	Codes	Participants
USR applications currently conducted	_Academic acts	_Seminars, conferences, workshops, certificate programs	_A3, A4, A7
	_Access to facilities	_24/7 Library	_A1, A2
	_Aiding projects	_collecting stationary, clothes and books	_A2, C3, S1, S3
	Student involvement	_student groups	_C4, C5, L1, S2
		_CBSL	_A4, A5, S1, S2, S3, S4, L2
	Counter ideas	_Dissemination of knowledge	A6, C7
	Additional USR	_historical acts	_C6
Current USR info. level		_women's issues	_L1
		_No info.	_A1, C1, C2, L3
		_Limited info.	_A4, A5, S1, S2, S3, S4, L2
Source of information	HEI's journal, public invitations, newspapers, on hearsay	(info. about CBSL) A1, C1, C2, L3	



The second category is ‘*access to facilities*’ of the hosting HEI that participant A2 summarizes the situation as; “A 24/7 library is a social service for Canakkale.” Participant S2, on thither hand, states that; “Student groups are carrying the load of SR on behalf of the HEI, not much is known besides these acts.” Participant C5 also praises student groups while criticizing HEIs as; “There aren’t any applications that put the community into its center, neither a concert nor a theatre. We only know the ones that student groups are organizing.” Unfortunately, there are also participants who do not have any info about current USR applications.

**The fourth interview question’s** objective is to analyze, what the participants think about the outcomes of current USR applications on behalf of scholars, students and the society.

**Table 6. Outcomes of USR Applications**

Theme	Category	Codes	Participants	
USR applications’ outcomes		_forming a culture	_A7	
		_accepting the USR duty	_A2, A6	
		_the need of taking social actions,	_A6	
		_improving personal skills and forming new relationships	_A4	
		_concrete outcomes	_A3	
		For the scholars	_eager to do new projects	_C3
			_interaction with the community and students	_L2
			_cooperation between formal institutions	_L4
			_interaction between students and scholars	_S4
				_S2
			_new research activities	
		For the students	_desire to do new projects	_A3, A4
			_positive future motivation	_A2, A7, C3, L2, S1, S2
			_and ‘learning from experiences	_A1, L4, S3, S4
		For the society	_interaction with the community	_A4, A7, L1, L2, S1, S4,
	_raised awareness	_A2, A6, C3, C4, C6, S4		

The possible and current outcomes that are mentioned by the participants on behalf of the **scholars** are; improving personal skills and forming new relationships with the community and with the stakeholders, desire to do new projects, forming better interaction and relations with their students and new research areas. For **students**, the desire to take part in new projects, more interaction with the society. And finally for the **society** itself, interaction with scholars and students, which will end up with a better engagement with all social partners.

**The fifth question of the interview** involves participants’ mutual expectations. The first and the most crowded category is named as ‘*the need of interaction*’ in which the participants believe that there must be an active interaction between HEI, CSO and LAs. The other groups are; ‘*knowledge transfer*’, ‘*leadership of HEIs*’ in which the participants (A4, A5, S1, S3= 18%) think that HEIs must be the key drive for a better HEI and stakeholder engagement in order to supply benefits to HEIs and ‘*criticism of HEI*’ in which the participants (C1, C2, C3, L1, A6= 23 %) mentioned their dissatisfaction of the current relations with the HEI. The data related to the fifth interview question are reflected in Table 7 below.

**Table 7. Stakeholders' Expectations**

Theme	Category	Codes	Participants
Mutual expectations of participants	_the need of interaction	Ex/As+ LAs+ CSOs+ Sts combining powers, sharing resources _all groups	A1, A2, A6, A7, C2, C4, C7, L2, L3, S1, S3, S4
	knowledge transfer	Ex/ CSOs+HEI _interchange of scientific & field knowledge	A1, A4, L3, C4
	leadership of HEIs	Ex/LAs+ CSOs + Sts _consensus on the leadership of HEI	A4, A5, S1, S3
	criticism of HEI	Ex/ LAs+ CSOs + Sts _having the power & resource, being away	C1, C2, C3, L1, A6

The mutual expectations of stakeholders are gathered around basic aspects like, combining the powers by means of sharing the resources for the social applications that are planned to do, and interchange of scientific knowledge. The need of an active interaction between the three formations, acting as a single unit for the benefit of the society is mentioned by more than the half of the participants. And the leadership role that is assigned to HEIs, which is believed to be the key driver of the expected interaction, whether it is not the current case. What's the current situation is the criticism of the HEIs, especially the hosting institution, for having the powers and being away from interaction at the desired level.

**The sixth question of the interview** examines participants satisfaction level of USR applications. Amongst the participants A3, A6 and S2 (% 14) clearly mentioned their *positive* satisfaction on the subject, by giving examples in relation with their domains. A3 believes that with the help of CBSL and student group activities, students are helping the schools that they are responsible of, by developing instructional materials, books and stationary aids, private lessons for the disadvantaged groups, town and village visits in order to supply the demands of the schools that are located in rural areas, interaction with administrators and parents and adds;

These applications are extensive in our Faculty of Education and can be regarded as formal SR applications. Personally speaking, I visit many countries in the territory two times a year for specific purposes and I believe that we accomplish our SR duties.

**Table 8. Stakeholders' Satisfaction Status of USR Applications**

Theme	Category	Codes	Participants
Participants' status of USR satisfaction	Positive	_Positive outcomes of CSBL, active student groups, town, village visits to supply local needs	_A3
		_the rich choice of certificate programs served by the HEI	_A6
	Negative	_official support for student groups	_S3
		_Lack of announcements/ info. related to the projects	_A2, A4
		_limited to USR applications of the Faculty of Education	_A7
		_lack of interaction with LA & CSOs	_C1, C3, C5, C6, C7
	_USR is profit focused	_L3	
	_student dissatisfaction	_S1, S3, S4	

Table 8 reflects a rich blend of criticism as of 12 participants (A2, A4, A7, C1, C3, C5, C6, C7, L3, S1, S3, S4= 55%) and A4 underlines this situation as; "Of course, there is an interaction between the HEI and

its stakeholders, but I do not find it enough.” Participant S1 criticized his peers for joining in CBSL activities just for grades and said; “No I am not satisfied! Whether its CBSL or other SR applications, I think that we are one step behind when it is compared to other places (countries).”

**The seventh question of the interview** asks what is likely to happen when HEIs and its stakeholders work together for the benefit of the society with an active cooperation. The first category ‘*more solutions*’ involve seven participants (A1, A2, A6, C3, C5, C6 =32%).

**Table 9. Possible Outcomes of Full Interaction**

Theme	Category	Codes	Participants
Personal viewpoints for the outcomes of full interaction	_more solutions	_decrease in current social problems	_A1, A2, A6, C3, C5
	_more projects		_A4, A5, A7, C1, C4
	_union of resources	_rich blend of demand based applications _combining powers save time and energy	_ C1, C2, C7, L3, L4 _ S1, S3, S4
	_mental change	_ positive effect of being involved in the community	

Participants (A4, A5, A7, C1, C4 = 23 %) who believed that the outcomes of full interaction would show its reflections with ‘*more projects*’. Participants from the CSO group have similar ideas with scholars that more projects could be formed and conducted with the help of the active cooperation. Furthermore, CSO members and LA employees (C1, C2, C7, L3, L4= 23%) underlined the need of combining the powers. Student participants (S1, S3, S4= 14%) shared ideas were to create a ‘*mental change*’. S1 emphasized that even if it can take a long time to foster this change, it would be effective and said; “Students could start to search the departments where they can be more useful, instead of searching the department where they can make money after graduation.”

The aim of **the final interview question** is to reach new ideas related to the future considerations of HEIs. Participants’ responses are gathered into four main categories as ‘*educational considerations*’ with eight participants (A3, A4, C2, C3, C6, L4, S2, S4 = 36 %) ‘*environmental considerations*’ with four participants (A1, A2, C3, L4, S4= 23 %), and ‘*cultural development*’ with three participants (A5, C1, C4= 14%). The data related to the last interview question are reflected in Table 10 below.

**Table 10. Stakeholders’ Perspective for Universities’ Future Considerations**

Theme	Category	Codes	Participants
Personal viewpoints for the USR applications that must be future considerations of HEIs	_educational considerations	_raising social awareness, requiring the demands of the labor market, institutional autonomy	_A3, A4, C2, C3, C6, L4, S2, S4
	_environmental considerations’	_the use of thermal reactors, recycling,	_A1, A2, C3, L4, S4
	_cultural development	_ going back to the roots, raising awareness and unity by cultural events, bringing together the polarized groups	_A5, C1, C4
	_the need of a specific USR unit	_ having the primary focus to create and conduct USR apps.	_A6, C6

Depending on the findings, participants generally regard educational aspects as the primary futuristic considerations combined with environmental considerations that affect the city positively from many perspectives. Moreover, a specific unit for USR planning and applications is required by two participants.

#### 4. Discussion

In this qualitative research, eight standardized open-ended questions are asked to 22 participants with seven Academicians, seven Community Service Organizations, four Local Authority employees and four undergraduate students who are regarded as the stakeholders of the HEI in Canakkale, Turkey. According to research results, SR and USR is found to depend on individual actions taken and small group activities in the hosting institution and the city itself. Findings state that all participants are aware of the positive outcomes of an active interaction between the HEI and its stakeholders, but not much is known about the current applications. The existing ones are a reflection of compulsory CBSL course, educational and individual applications. Stakeholders and the HEI have higher mutual expectations underlining the dissatisfaction of the current interaction. Participants assign a leadership role on HEIs in order to create a better environment and interactive stakeholders for the benefit of the society. The findings of the research revealed that educational, environmental and cultural development are regarded as the primary future considerations of HEIs.

#### 5. Recommendations

Within the assigned role of leadership for HEIs, committees, administrative units, scholarly practices, contribution of local partners must be supplied under dimensions that the locals, in the first row, and society in general can benefit academic and social practices conducted by hosting institutions of the local settings.

As CBSL is seen a driver factor for student to be engaged with the society, the equivalent of the course could be designed for other faculties of the university.

Organization of specific units in stakeholder parties responsible for planning and arranging more social applications designed to supply the needs of the locals.

Not only required active interaction with the local stakeholders, but also with international organizations can help to find scholarships, fundings, philanthropic contributions or new partnerships within a broader sense of engagement in a global point of view.

#### 6. References

- AAC&U (2008). "Should Colleges Focus More on Personal and Social Responsibility?" Center for the Study of v Higher and Postsecondary Education University of Michigan School of Education 610 E. University Ann Arbor, MI 48109-1259.
- Ackoff, R. L. (1981). *Creating the corporate future*. Chichester: Wiley.
- Allen, M. (1988). *The goals of universities*. Milton Keynes: Society for Research into Higher Education/Open University Press.
- Barnett, R. (Ed.). (1990). *The idea of higher education*. Buckingham: Society for Research into Higher Education; Open University Press.
- Benneworth, P. and Jongbloed, B. W. (2010). Who matters to universities? A stakeholder perspective on humanities, arts and social sciences valorisation. *High Educ (2010) 59:567–588*. Published online: 31 July 2009.
- Bierhoff, H. W. and Rohmann, E. (2004). Altruistic personality in the context of the empathy altruism hypothesis. *European Journal of Personality, 18 (4)*, 351-365.
- Burrows, J. (1999). Going beyond labels: A framework for profiling institutional stakeholders. *Contemporary Education, 70 (4)*, 5–10.
- Cantor, J. (1995). *Experiential learning in higher education: Linking classroom and Community*. Washington, DC: The George Washington University.
- Cooper, C.,(2005). Accounting for the public interest: public in officials or public intellectuals. *Accounting, Auditing and Accountability Journal* 18 (5), 592–607

Retrieved from <http://www.emeraldinsight.com/Insight/ViewContentServlet?Filename=Published/EmeraldFullTextArticle/Articles/0590180502.html>.

- Drucker, P. F. (1996). *Yonetim Uygulamasi*. (Cev: E.S. Yarmali). Istanbul: Inkilap Kitapevi
- Erdem, A. R. (2013). Bilgi toplumunda universitenin degisen rolleri ve gorevleri. *Yuksekokretim Dergisi*, doi:10.2399/yod.13.013
- Ernste, H. (2007). The international network university of the future and its local and regional impacts. In A. Harding, A. Scott, S. Laske and C. Burtscher (eds) *Bright satanic mills: universities, regional development and the knowledge economy*, Aldershot: Ashgate
- Fitzgerald, G. A. (2012) Engaging Faculty In Community Engagement. *Journal of College Teaching and Learning* – Second Quarter. Volume 9, Number 2.
- Fitzgerald, H E., Smith, P., Book, P., Rodin, K. (2005). *Engaged Scholarship: A Resource Guide. Draft Report submitted to the Committee on Institutional Cooperation*.
- Fraser, F. (2005). Four different approaches to community participation. *Community Development Journal* 40, 286-300.
- Furco, A. (2001). Advancing service learning at research universities. In M. Canada and B.W. Speck (Eds.), *Developing and implementing service learning programs* (pp. 67-78). San Francisco: Jossey-Bass Publishers.
- Geryk, M. (2011). "Are universities socially responsible?" EFMD *Global Focus* .Volume 05.Issue 03.
- Gilchrist, A. (2009). *The well-connected community: A networking approach to community development, 2nd edition*. Bristol, UK: The Policy Press.
- Gunay,E. (2011).Turk Yuksekogretiminin Yeniden Yapilandirilmesi Baglaminda Sorunlar, Egilimler, Ilkeler ve Oneriler – I, *Yuksekokretim ve Bilim Dergisi/Journal of Higher Education and Science. Cilt/Volume 1, Sayi/Number 3, Aralik/December 2011; Sayfa/Pages 113-121. DOI: 10.5961/jhes.2011.017*
- Hall, P., (2010). Community engagement in South African higher education.Kogisano 3–53 *SouthAfricanCouncilonHigherEducation. (6)*
- Karima R, Oshima Y, Yamamoto K. (2006). Identification of subjects for Social Responsibility Education at Universities and the present activity of the University of Tokyo. *Environmental Science, 13 (6):327-337*.
- Magilvy, J. K. (2003). *Qualitative designs*. In K.S. Oman, M. Krugman, & R. Fink (Eds.), *Nursing research secrets* (pp. 123–128). Philadelphia: Hanley & Belfus, Inc
- Marginson, S. (2007). University mission and identity for a post post-public era. *Higher Education Research and Development, 26 (1), 117–131*.
- Merriam, S. B., & Associates. (2002). *Qualitative research in practice*. San Francisco: Jossey-Bass.
- Mizikaci,F. (2012). Avrupa Bilgi Toplumunu ve yuksekogretim: Gelenek ve donusum arasindaki universite.*Yuksekokretim Dergisi 2(2): 95-103*
- Morton, K., and Troppe, M. (1996). *From margin to mainstream: Two cases of institutionalizing service-learning: How campus climate affects the change process*. Providence: Campus Compact.
- OECD (2007), *Higher Education and Regions, Globally Competitive, Locally Engaged*, Paris. Organisation for Economic Co-operation and Development (2007) Higher education and regions: globally competitive, locally engaged, Paris: OECD.
- Perkmanna, M., Tartari,V., McKelveyb, M., Autioa,E., Brostromc,A., D’Ested, P., Fini,R., Geunae,A., Grimaldif, R., Hughesm, A., Krabelh, S.,Kitsong, M., Llerenai, P., Lissonij, F.,Salter, A., Sobrerof, M. (2013). Academic engagement and commercialisation: A review of the literature on university–industry relations. *Research Policy 42 (2013) 423– 442*.
- Ridenour, J. (2007). *The Role of Spirituality and the Impact on Social Responsibility*. Dissertation. Graduate Department of Clinical Psychology George Fox University. Newberg, Oregon.
- Scott, P. (2002). Kuresellesme ve Universite: 21. Yuzyilin Onundeki Meydan Okumalar (Ceviren: Seda Ciftci), *Kuram ve Uygulamada Egitim Bilimleri, 2 (1),191–208*
- Serow, R., Calleson, D., Parker, L., and Morgan, L. (1996). Institutional support for service-learning. *Journal of Research and Development, 20 (4), 220-226*.

## The Stakeholders' Perspectives for Universities' Social Responsibilities

- Shawyun, T., Al-Kami, A., Al-Shehri, M., Al-Hamali, R. (2012). From csr to usr: a strategic usr management framework. Proceedings of the 7th QS-APPLE Conference Manila, 16th -18th November, 2011. Published June, 2012., p. 115-130
- Slaughter, S., & Leslie, L. (2001). Expanding and elaborating the concept of academic capitalism. *Organization, 8* (2), 154–161
- Starrett, R.H. (1996). Assessment of global social responsibility. *Psychological Reports, 78*, 535-554.
- Tosado, G. M. S. (2011). *Developing Awareness of Social Responsibility in Higher Education in Puerto Rico: A Case Study at the Universidad Del Sagrado Corazon.*
- Vickers, M., Harris, C. and McCarthy, F. (2004). University community engagement-exploring service learning options within practicum. *Asia Pacific Journal of Teacher Education 32* (2), 129–139.
- Zlotkowski, E. (1996). Linking service-learning and the academy. *Change, 28* (1), 20-28.



# Quality Assurance Practices in Belgian Universities

Aysun Caliskan, Hasan Arslan

## Introduction

Universities, the most important component of education, have been the institutions that support change for years. Their ability to adapt to change has made very effective institutions for society. At universities, traditions are in contradiction with creativity, universal thought with local or national values, institutional autonomy with academical sovereignty, social duties, economics and politics (Sakarya, 2006). If a country reaches the global standards in higher education, it can easily and safely give shape to its future on solid foundations. From this fact, in all developed or developing countries, higher education has been under continuous review, and it remains on the agenda of governments, private sector and the media (Erisen and Celikoz, 2004).

## Quality

In order to be able to reach global standards and to yield “internationalisation”, all endeavors and activities need to have a certain level of quality.

Quality, in general sense, can be defined as the “accordance to the desired feature” or “conformation to the standards determined by an authority”. However, the notion “quality”, in paralel with the expectations of the society, has begun to be rather perceived as “compatibility to the goals” or “convenience for use” (Adiguzel, 2008). The society expects the individual to be cultivated in terms of creativity, problem-solving, ability to use sophisticated technology, competency in scientific thought and socially developed. The most important institution to meet these expectations are the universities. Universities have to form their quality standards in order to raise individuals who are open to improvements, free in thinking, investigative and self-improving (Eytimis, 2000).

## Quality in Higher Education

Quality in higher education is an educational process which help the learners realize their goals, endows the society with its expectations and contributes to the national development (Mishra, 2007). Quality assurance, for an organisation, means all units acting in the direction of the same objective to yield a product or service that fully meets the needed requirements or the desires (Uzel, 1998).

## Quality Assurance in Higher Education

Higher education is the institution where education, teaching and investigation takes place. Quality assurance in higher education is the evaluation and improvement of the activities related to education, teaching and investigation comprehensibly, systematically and regularly (Schwarz&Westerheijden, 2007).

Each country and university charts out to accomplish quality assurance pertinent to its geography, population, history and language. To accomplish quality assurance in a country, it is required to fulfil the expectations of the foreign students. By this, quality assurance in higher education can be met. By stimulating the foreign student, the other students are also motivated. Because higher education is costly, each university needs to merit the investment by presenting a high enough quality standard. Presently, individuals have the chance to differentiate between the universities with respect to their level of quality thanks to quality assurance practices. The universities are, then, obliged to operate accordingly to the quality standards (Kawaguchi, 2012). This being the case, universities are directed to make innovations in their activities in terms of education, teaching methodology and other services. This change started with the Lisbon Process in Europe, was formed through the Bologna Process and has been improved through the following processes.



### **Quality Assurance Practices in Europe**

In the field of higher education in Europe, the main idea is not to plan, implement, assess or monitor the quality of education through the input but through the educational attainment. The works or studies carried on in parallel to the improvements in the world are implemented within the scope of European Higher Education Field/Bologna Process. The objective is to train students so that they have an awareness of the world and are open to change (Elmas, 2012).

In the assessment phase, countries or the higher education institutions who are the members to the Bologna Declaration are not imposed on their involvement in the process. On the contrary, the decisions to implement the standards are made by those institutions (Bologna Declaration, 1999).

The enactment of quality assurance in education is one of the most important goals of the Bologna Process. Since the Declaration was signed, almost every higher education institution in Europe has been aware of the importance of quality assurance. European ministers, being conscious of the importance of disseminating knowledge, have focused on improving quality assurance in education. Therefore, they have founded the European Network on Quality Assurance in Higher Education. That institution is in charge of deciding on what to do in the process of implementing the quality assurance in Europe, and defining and mainstreaming the basic quality standards. With a view to achieving those goals, all the agencies within the range of European Higher Education Field should be involved in the process (ENQA, 2009).

### **European Standards for Quality Assurance in Higher Education Institutions**

#### *The Objectives of Standards and Principles*

The objectives of standards and principles are as follows:

- The improvement of existing education at higher education institutions that are in EHEA;
- To give assistance to higher education institutions to manage and improve their quality, and thus to provide them with institutional sovereignty;
- To provide quality assurance agencies with a substructure;
- To make external quality assurance more transparent and comprehensible for all participants (ENQA, 2009).

### **The European Standards of Internal Quality Assurance for Higher Education Institutions**

**Quality assurance policies and procedures:** Institutions need to have their own policies and common procedures to ensure the assurance of their quality and standards of their programs and awards. They should consider themselves responsible for the works they perform and the expansion of a common sense that recognizes the importance of quality assurance. To accomplish this, institutions should devise and implement strategies for the continuous improvement of quality. Strategy, politics and procedures must have a formal status and be available to public. They should also cast a role for students and other participants.

**Endorsement, supervision and inspection of programs and awards:** Institutions must have formal mechanisms for the endorsement, supervision and periodical inspection.

**Evaluation of students:** Students must be evaluated through promulgated criteria, regulations and procedures to be implemented consistently.

**Quality assurance of the teaching staff:** Institutions need to have convincing methods about the competency and authorization of the staff in charge of teaching students. Those methods must be available to the ones responsible for the external inspections and need to be defined on reports.

**Teaching resources and student support:** Institutions must guarantee that existing resources supporting the students in the activity of learning are sufficient and suitable for every program offered.

**Information systems:** Institutions must be able to guarantee that they accumulate, analyze and implement information to efficiently manage their study programs and other activities

**Public information:** Institutions must regularly make public the current, unbiased and objective information in both quantitative and qualitative manner.

### **The European Standards of External Quality Assurance for Higher Education Institutions**

Implementation of the internal quality assurance procedures: External quality assurance procedures should consider the efficiency of the internal European standards and principles. Improvement of the external quality assurance processes: Before the very procedures are developed, the objectives and goals of quality assurance procedures must be decided on by all parties concerned (including the higher education institutions) and be published together with the definitions to be implemented.

**Criteria for decisions:** Any formal decision as a result of an external quality assurance activity has to be based on clear criteria which are in practice.

**Expedient processes:** All external quality assurance processes must be specially designed to guarantee the expediency for the objectives determined for them.

**Reporting:** Reports need to be written and published in a style that they are easily obtained by the audience. Any decision, comment or suggestion included on those reports must be easily accessible.

**Monitoring procedures:** Quality assurance processes involving suggestions or requiring a supervening activity planning must have a consistently implemented and foreordained monitoring procedure.

**Periodical inspections:** The external quality assurance of institutions and/or programs should be handled on a regular basis. The length of the period and inspection methods to be used must be clearly defined and promulgated beforehand.

**System wide analyses:** Quality assurance agencies, at intervals, must produce reports defining and analyzing their own inspections, assessments and judgments. (ENQA, 2009).

All European countries have been endeavoring to reach higher education standards. However, having a politically important position due to being the capital of the European Union, educational studies have also reached significant magnitude in Belgium.

In this study, the quality assurance systems of the universities located in Belgian Flemish region will be scrutinized.

### **Belgian Flemish Region Higher Education System**

Including the Flemish, French and German communities, Belgium is composed of 3 regions. In the Flemish region, rapid modernization and strong emphasis on socio-economic values have been accompanied by intensive involvement in educational processes. Quality inspection agencies and studies at higher education are significant.

The Flemish region, with its population of 6.3 million, constitutes the 57 % of the total Belgian population and 44 % of the country's lands. For the last two generations, rapid modernization and strong emphasis on socio-economic values have been accompanied by intensive involvement in educational processes.

When compared to many other countries, the Flemish region has achieved a very high level of academic success (Karakelle, 2014). The Flemish government is in charge of education in the Flemish region. The framework for the higher education is determined by the Higher Education Codex. The Flemish government divided the universities in two, which are legally registered institutions and the legally unregistered institutions. As the date of March 2014, 5 universities and 17 colleges are located

in the region. Universities are split into programs with regard to the regulations enacted by the Higher Education Commission. At universities, there are 5 different programs, including associate degree, academic bachelor's degree, vocational bachelor's degree, master's degree and doctorate's degree. Universities are completely autonomous in determining their curriculum; however, they have to conform to the regulations of the Higher Education Commission (VLUHR, 2014).

### **Quality Assurance in the Flemish Region**

There is an organization in Flanders, Belgium that informs the government on the studies conducted by the universities. This organization is the Flemish Interuniversity Council (VLIR) which was founded in 1976, in order to ensure mutual communication and coordination between universities. VLIR informs Flemish government about the policies in which the universities are involved. Senior executives and specialist staff in the universities cooperates with VLIR in order to ensure consensus a wide range of issues such as degree structure, research management, quality assurance, academic administration etc. (VLIR, 2015).

The higher education in Flanders experienced significant changes in 1991. One of the key elements in the arrangements made in Higher Education was the quality assurance system. All higher education institutions are given autonomy pursuant to the governmental policy. The government confers to the universities the responsibility of preparing their own quality policy; however, the quality control in higher education is still conducted by the government. (Wit & Verhoeven, 2004). It is NVAO's responsibility to decide upon whether or not a university in Flanders ensures Quality Assurance. NVAO is an institution that evaluates the Netherlandish and Flemish university programs and provides them with Quality Assurance and Accreditation.

The quality assurance system in Flanders consists of three sections.

**Internal Quality Assurance:** This is the process of the evaluation of the programs and preparation of the internal evaluation report by the higher education institution itself.

**External Quality Assurance:** This evaluation is done every 6 years. Internal evaluation report is considered to be the start point of the external quality assessment process. An evaluation report is prepared as a result of external quality assessment. VLHORA and VLR are responsible for the external quality assessment process. These organization ensure establishment of independent review panels by the experts responsible for evaluating all programs in a certain area during the evaluation process. The evaluation panel consists of field experts, quality assurance experts, and education professionals and experts responsible for international development of the field. These panels also involves students (NVAO, 2008).

The main features of the external quality assurance system:

- Training programs of the same school are evaluated in the same period,
- The process starts with the review of the internal evaluation report required to prepare the program,
- Independent experts visit the panel and the program, meet with the concerned people about the quality of the program, provide feedback on the quality of the program and make recommendations for improvement.
- The evaluation report indicates the quality profile of the program,
- Evaluation process ends up with the publication of an official report. The report includes comparative definitions and tables.
- The procedures of visit and evaluation procedures are included in the Flemish Higher Education External Quality Assurance guide.
- The report is submitted to NVAO by the universities for accreditation (VLUHR, 2014).

**Official Decision Process:** Institutions which successfully get over the external quality assessment submit their evaluation reports. NVAO assesses the external quality assessment report carefully and accepts/rejects the findings. If the accreditation decision is positive, the program becomes accredited.

This result means that the program is registered in the Higher Education Registries. The program becomes accepted by the Flemish national authority.

In addition, the programs accredited can obtain public funding and the students enrolled in these programs can get financial support such as grants. However, public funding and student support does not apply to programs offered by private institutions. As the positive accreditation decision by the NVAO is obtained, the institution gets listed in the Higher Education Registries for a period of 8 years. If the accreditation decision is negative, the program lose their accreditation right. Such program is excluded from the Higher Education Registries and is not allowed to enroll student any more. In addition, such program is given a provisional recognition in the process of a recovery period. Following the negative accreditation decision, the institution may submit an application to the Flemish government for provisional recognition. This application must be submitted within 1 month as of the date of negative accreditation decision. A detailed implementation and improvement plan is prepared through. Through following the advices from the Recognition Commission, the Flemish government takes a decision within three months in the implementation. The provisional recognition may have a validity for 1 to 3 years. In NVAO accreditation system, the learning outcomes are used in three levels. A program is required to clearly identify the intended learning outcomes. These are the qualifications acquired by a grad student during studies.

The evaluation panel first judges whether or not the program's learning outcomes are in compliance with the expected level and the subject matter of the program. The level is evaluated by matching European Higher Education Area Qualifications Framework with the intended learning outcomes. In addition, the evaluation panel assesses whether these learning outcomes are in line with the expectations from the program in national/international terms. NVAO secondly evaluates the potential learning outcomes. These outcomes constitute the qualifications attainable by the student as presented in the program.

This is conducted through taking into consideration the basically intended learning outcomes and the content of the curriculum. They are expected to conform to European Higher Education Area Higher Education Qualifications Framework. If a program defines laboratory skills as the intended learning outcome, the program curriculum should clearly include that and allow student to make laboratory studies. Otherwise, it would be considered that there is no cohesion between curriculum content and intended learning outcomes. Certain input elements such as facilities, quality and quality of staff also contribute to the achievement of learning outcomes. Therefore, they are also considered. Thirdly, NVAO assesses the learning outcomes achieved. These are the qualifications acquired by the grad student during his studies. In order to see whether or not there is a cohesion between the learning outcomes achieved and those expected, the evaluation panel is required to read the students' papers, term papers and theses. (NVAO, 2008).

## **Conclusion**

Certain significant changes take place in the European higher education system. Higher education systems are changed in order to meet the growing needs of the society, to increase participation in education, to support the students and the educational process and to meet the demands of the labor market. During this change, the purpose should not be only to support young people to enroll in the universities. Higher education system should ensure young people to succeed, develop the young people's self-confidence to provide them with opportunities for acquiring professions. In order to achieve these objectives in higher education, Belgium Flemish Government has developed a system of quality assurance in higher education.

In order to ensure greater autonomy, the Flemish universities implemented an internal and external quality system in 1991. The government conferred to the universities the whole responsibility in ensuring quality assurance. Thus, the universities could take initiatives and had right to control their quality. (Dassen & Luijten-Lub, 2007).

When universities are granted the right to autonomy and responsibility, all Flemish universities had to develop a quality assurance system. Each university seeks to provide both internal and external quality assurance. Thanks to the quality assurance, universities:

- have started to monitor the quality of their education and research activities
- have established a system in order to make regular assessments (at least, once in 8 years) with other Flemish universities and universities abroad
- have taken into account the evaluation results in their policies and presented the results to the Flemish government in an annual report

It is the government's responsibility to control and audit the quality assurance systems through controlling the quality assurance programs established by universities, appointing a commission to conduct comparative researches on the quality of educational activities in a particular course and following the how policies are implemented by the universities (Wit & Verhoeren, 2004).

In today's world, education is considered as the most important factor of political and economic development. When considered from a European perspective; different systems and methods are implemented in order to ensure of quality in higher education. The Flemish government in Belgium works seriously on this subject and makes corrections to eliminate missing points.

## References

- Adiguzel, A. (2008). Egitim Fakultelerinde Ogretmen Egitimi Program Standartlarinin Gerceklesme Duzeyi. Yayimlanmamis Doktora Tezi, Anadolu Universitesi, Eskisehir.
- Bologna Declaration (1999). *Joint Declaration of the European Ministers of Education*. retrieved from <http://www.bolognabergen2005>, 20.01.2015
- Dassen, A. & Luijten-Lub, A. (2007). Higher Education In Flanders- Country Report. CHEPS: Netherlands.
- Elmas, M. (2012). Bologna Sureci: Uygulama, uygulayamama. *Yuksekogretim ve Bilim Dergisi*, Cilt 2, Sayi 3, 137-141.
- ENQA. (2009). Standards and Guidelines for Quality Assurance in The European Higher Education Area, 3rd Edition, Helsinki: Finland.
- Erisen, Y. & Celikoz, N. (2004). Teknik Egitim Fakultesi Ogretim Elemanlarinin, Egitim Programlarin Niteligine Iliskin Goruslerinin Bazi Degiskenler Acisindan Incelemesi . XIII. Ulusal Egitim Bilimleri Kurultayi, 6-9 Temmuz 2004 Inonu Universitesi, Egitim Fakultesi, Malatya.
- Eyitmis, A. M. (2000). Yuksekogretimde Toplam Kalite Yonetimi ve Uludag Universitesi I.I.B.F'de ISO 9002 Kalite Guvence Modeli Onerisi. Yayimlanmamis Yuksek Lisans Tezi. Uludag Universitesi, Bursa.
- Karakelle, M. (2014) Egitim sistemini donusturen ulkeler 2: Belcika <http://www.egitimpedia.com/egitim-2/egitim-sistemini-donusturen-ulkeler-2-belcika-flaman-bolgesi>
- Kawaguchi, A. (2012). *Quality Assurance For Higher Education in Japan*. National Institution for Academic Degrees and University Evaluation, NIAD-UE.
- Mishra, S. (2007). *Quality in Higher Education*. National Printing Press: India. UOA. (2015). University of Aberdeen, Academic Quality Handbook, Chapter 2: Quality Assurance in Higher Education. <http://www.abdn.ac.uk/staffnet/teaching/academic-quality-handbook-838.php>
- NVAO(2008). Higher Education Qualifications Framework in Flanders (Belgium) A presentation for compatibility with the Framework for Qualifications of the European Higher Education Area, [http://nvaio.com/page/downloads/NOF\\_Flemish\\_National\\_Qualifications\\_Framework.pdf](http://nvaio.com/page/downloads/NOF_Flemish_National_Qualifications_Framework.pdf)
- Sakarya, M. C. (2006). Yuksekogretimde Ogrenciye Yonelik Hizmet Kalite Olculmesi: Akdeniz Universitesi Iktisadi Idari Bilimler Fakultesi Ogrencileri Uzerine Bir Arastirma. Yayimlanmamis Yuksek Lisans Tezi, Akdeniz Universitesi, Antalya.
- Schwarz, S., & Westerheijden, D.F. (2007). Preface. In Schwarz, S., & Westerheijden, D. F. (Eds.), *Accreditaion and evaluaion inthe European higher educaion area* (pp. ix-xii). Springer.
- Uzel, I. (1998). Kalite Guvence Sistemlerinde Egitim Ve Bir Uygulama. Yayimlanmamis Yuksek Lisans Tezi, Sakarya Universitesi, Sakarya.
- VLIR (2015). Flemish Interuniversity Council. <http://www.vlir.be/content1.aspx?url=english>

## Quality Assurance Practices in Belgian Universities

- VLUHR (2014). Report of the Panel appointed to undertake a review of the Quality Assurance Unit of the Flemish Council of Universities and University Colleges (VLUHR QA). [http://www.vluhr.be/default\\_EN.aspx?PageId=523](http://www.vluhr.be/default_EN.aspx?PageId=523).
- VLUHR (2014). Self – evaluation report  
[http://www.vluhr.be/media/docs/VLUHR\\_ENQA%20peer%20review\\_ZER\\_def.pdf](http://www.vluhr.be/media/docs/VLUHR_ENQA%20peer%20review_ZER_def.pdf)
- Wit, K. & Verhoeven, J. (2004). Autonomy vs. Control: Quality Assurance and Governmental Policy in Flanders. Education Policy Analysis Archive, Volume 12 Number 71 December 22, 2004 ISSN 1068-2341



# **An Investigation of Parents' Habits of Reading Books to their Children and their Criteria for Selecting Children's Books**

Yesim Yurdakul, Utku Beyazit, Sukran Simsek, Aynur Butun Ayhan

## **1. Introduction**

As a complex cognitive process, reading is realized through a combination of various functions such as seeing, perceiving, and giving meaning and interpreting (Balci, 2009; Bamberger, 1990; Butun Ayhan et al. 2014; Ozturk and Aksoy, 2016). The habit of reading is defined as the individual pursuing the reading action continuously and critically throughout his life (Balci et al., 2012; Butun Ayhan et al., 2014; Dreher, 2002).

Reading books affects all developmental areas by creating a natural learning setting. Also, it fosters children's creativity, skills, abstract thinking and imagination (Butun Ayhan et al., 2014; Durualp et al., 2013; Hughes-Hassell & Rodge, 2007, Kakirman Yildiz, 2017; Tezel Sahin and Tutkun, 2016). Reading at pre-school stage does not only contribute to the understanding skill of children but also help them to move towards written languages from oral language (Beyazit and Butun Ayhan, 2016; Sever, 2008). It is emphasized that children who gain the habit of reading at early ages learn reading more rapidly, become more academically successful and have higher languages gains (Ozturk and Aksoy 2016; Yildiz Bicakci et al., 2018). If the child does not take up the habit of reading at early ages, it becomes more difficult to take up this habit, at later stages (Sahin et al., 2012). That is why, the non-compulsory education provided at early years is important to take up reading as a habit (Cakmak Gulec and Gecgel, 2005; Kakirman Yildiz, 2017; Özturk and Aksoy, 2016). It is underlined that fostering reading starting from early childhood is fundamental in increasing reading habit in the society (Hopper, 2005; Johnson-Smaragdi & Jonsson, 2006; Sangkaeo, 1999).

The interest in reading and reading habit varies according to individual characteristics of children such as the age, gender, reading experiences of children as well as environmental factors. Such environmental factors include family, society the children live in, teachers and mass communication tools (Balci et al. 2012, Butun Ayhan et al., 2014; Cilgin, 2007; Sever, 2008; Tezel Sahin and Tutkun 2016). Families knowing their children well, fostering their development through well-selected books, organizing reading hours including all family members, arranging a bookshelf for their children even if it is a single shelf, going to the library together, allowing children to review, select and read the book they have selected motivates children about reading (Beyazit and Butun Ayhan, 2016; Ozturk and Aksoy, 2016; Sahin, 2012; Tanju, 2010; Tezel ŞSahin and Tutkun, 2016). Investigation of parents' habit of reading to their children during pre-school stage and their criteria for selecting children's books is crucial for studies focusing on helping children gain reading habit. Hence, this study aims to investigate parents' reading habits to their children at pre-school stage and their criteria for selecting children's books.

## **2. Method**

The section presents information regarding the research design, participants' features, data collection tool and process, and data analysis.

### **2.1. Research Design**

The study aims to investigate parents' reading habits to their children at pre-school stage and their criteria for selecting children's books. In this regard, case study method was implemented as a qualitative research method. Case study is a qualitative research method where factors (events, processes, individuals, time, place, etc.) relevant to one or more than one situation are analysed as a whole within their limits, how these factors affect the specified situation and how they are affected by the situation are examined in detail (Yildirim & Simşek, 2016).



## 2.2. Participants

In accordance with case study research design, the study group of the research includes 12 parents with pre-school aged children living in Antalya city and who were selected through purposive sampling. All participants are mothers. Participants' children who are continuing in pre-school include seven girls and seven boys. Three of the participating mothers are at the age of 30 or below, six of them are at 31-35 age range, four of them are at 36-40 age range and one of them is at 41-45 age range. Out of the seven working mothers, one of them is illiterate while three are primary school graduates, seven are secondary school graduates, two are high school graduates and one is university graduate. When the fathers' ages are examined, it was seen that five of them are at the 31-35 age range, six of them are at 36-40 age range, two of them are at 41-45 age range and one of them is at 46 or above age range. Out of the twelve working fathers, two are primary school graduates, one of them secondary school, eight of them high school and three of them are university graduates. When the order of birth of the children of participating mothers is observed, it is seen that eight of the children are the first child, two are second, and four are the last. When the income levels of the families are reviewed, four of them are low-, nine are middle- and one of them is high-level income.

## 2.3. Data collection tools and data analysis

In accordance with qualitative data collection method, the study used the semi-structured interview form prepared by the researchers and finalized after expert opinion. In addition to the interview form, a personal information form prepared by the researchers was also implemented to determine the demographic background of the participants. Audio recorders were used during the interviews with the participants. The data from the audio recorders were then, transcribed. Content analysis was used for the analysis of the data collected through the interviews. After the transcription of the audio responses to the interview questions, themes and sub-themes were identifying based on the responses. Themes were subjected to content analysis and analysis was conducted to determine frequency and percentage over the collected data. Later on, themes and sub-themes were organized and findings were interpreted.

## 3. Findings

The qualitative data of the study was collected through semi-structured interview forms. Content analysis was used for the analysis of the collected data. Themes and sub-themes were identified based on the given responses, and analysis to determine the frequency and percentage of the sub-themes were conducted.

### 1.Parents' case of reading to their children

Parents' case of reading to their children at pre-school stage was asked and the audio responses revealed that all participants read to their children.

### 2.The age range at which parents start reading to their children

Parent were asked at which age they start reading to their children and the sub-themes of 0-12 months, 13-24 months, 36 months, 48 months, 60 months were identified regarding the theme of the age parents start reading to their children. The percentages and frequency values of the sub-themes are presented in the table.

**Table.1. Age range at which parents start reading to their children**

Sub-theme	Frequency	Percentage	Participant
0-12 months	1	7, 14	M9
13-24 months	3	21, 42	M5, M6, M11
36-48 months	9	64, 28	M1, M2, M3, M4, M5, M9, M10, M13, M14
60 months	1	7, 14	M12

## An Investigation of Parents' Habits of Reading Books

When Table 1 is reviewed, it is seen that 9 of the parents start reading to their children between 36-48 months, three of them during 13-24 months, one of them between 0-12 months, and one of the at 60 months. Some of the responses from the participants are given below:

*"My daughter was months old. She was around 9 months."* (M8); *"I try to read whenever he wants since 3,5-4 years."* (M1); *"At 3-4 years."* (M2); *"Since 1,5- 2 years."* (M6); *"I started reading since 3 years."* (M13); *"We are reading since the age of 3."* (M10)

### 3. Parents' frequency of reading to their children

Parents were asked how often they read to their children and based on the responses, these sub-themes were formed: I read whenever I want, I read 3-4 times a week, I read 1-2 times a week, I read every day. Percentage and frequency values of the sub-themes are given in the table.

**Table.2. Parents' frequency of reading to their children**

Sub-theme	Frequency	Percentage	Participant
I read whenever I want	2	14, 28	M1, M4
I read 3-4 times a week	3	21, 42	M2, M3, M7
I read 1-2 times a week	2	14, 28	M9, M11
I read everyday	9	64, 28	M2, M5, M6, M7, M8, M10, M12, M13, M14

When the frequency of parents reading to their children are reviewed from Table 2, it is noticed that 9 of the participants read every day, 3 of them read 3-4 times a week, two of them read 1-2 times a week and 2 of them read when the parent wants. Some of the participant responses about this issue is as follows:

*"Whenever my child wants. When he wants. Especially sometimes I was reading at nights"* (M1); *"We read every night"* (M5); *"Every day. Every free time we get. We always read every night."* (M8); *"Although the frequency changes, once or twice a week."* (M11)

### 4. Participants' responses regarding which parent reads to their children

Parents were asked which parent reads to the children and sub-themes of only the mother reads and mother and father reads were formed based on the responses. The responses showed that ten of the participants stated that only the mother reads while four of them said both mother and father reads. Some of the responses are given below:

*"Generally I read. The mother."* (M1); *"Me and the father. Mostly me."* (M2); *"Generally I read but the father also reads."* (M9); *"I, always I read."* (M10)

### 5. Parents' views on who selects the books to be read

Regarding the theme of who selects the books, the sub-themes that were identified are: the child selects, we select together, parents select. The percentage and frequency values of the sub-themes are given in the table.

**Table. 3. Views on who selects the books to be read to children**

Sub-theme	Frequency	Percentage	Participant
The child selects	5	35,71	M1, M4, M5, M8, M9
We select together	5	35,71	M2, M6, M7, M12, M14
Parents select	4	28, 57	M3, M10, M11, M13

When the responses regarding who chooses the books to be read from Table 3 are observed, it is found that five participants said the child selects; five of them said they select together and four said the parents select. Some of the participant responses are as follows:

*"He chooses himself."* (M5); *"We choose together with my daughter."* (M6); *"I choose for now."* (M10).

### 6. Parents' case of going to the library with their children

After asking the parent about them going to the library with their children the sub-themes of we go to the library together and we don't go to the library were formed. When the responses were reviewed, it was found that eleven of them stated that they do not go to the library and three of them said they go to the library together. Some of the participants' responses are given below:

*"No, we haven't been to the library yet." (M1); "I go to the library together. I haven't been to the library in this school semester but before, we had regular library days. We has a very big library in our school and we used to attend it regularly, we had reading days when we were in Istanbul." (M2).*

### 7. Case of having a bookshelf that belongs to the child

During the interviews, parents were asked whether they formed a bookshelf for the child or not and the responses revealed the following two sub-themes: there is a bookshelf belonging to the child and there is a drawer, basket, etc. that the child puts his books. Percentage and frequency values regarding the sub-themes are presented in the table.

**Table.4. Case of having a bookshelf belonging to the child**

Sub-theme	Frequency	Percentage	Participants
There is a bookshelf belonging to the child	12	85, 72	M1, M2, M3, M4, M5, M6, M8, M10, M11, M12, M13, M14
There is a drawer, basket, etc. the child can put his books	2	14, 28	M7, M9

When the participants' responses from Table 4 are reviewed, it is seen that twelve children own a bookshelf and two of them has a drawer, basket, etc. to use for their books. Some of the participant responses are as follows:

*"Not yet but I'm thinking about it. Now that she has started school I'm considering it in her room." (M1); "We can say that we have a small bookshelf." (M2); "Yes, we have a bookshelf. Both his older sister and he use it. They both have separate shelves" (M3); "Yes, he has a basket and we put the books there. We pick the books he wants and read it to him at night." (M7).*

### 8. Parents' aims in reading to their children

Parents were asked about their aims in reading books to their pre-school aged children and the responses were categorized under these sub-themes: foster language development; improve imagination; foster cognitive development; gain and like reading habit; help sleep easily; providing information; foster literacy skills; and foster social skills. The percentage and frequency values regarding the sub-themes are given in the table below.

**Table.5. Parents' aims in reading to their children**

Sub-theme	Frequency	Percentage	Participants
Foster language development	7	50	M5, M6, M7, M8, M9, M11, M13
Improve imagination	7	50	M3, M6, M9, M10, M11, M12, M14
Foster cognitive development	5	35, 71	M2, M7, M10, M11, M14
Gain and like reading habit	5	35, 71	M3, M9, M11, M12, M13
Help sleep easily	3	21, 42	M6, M9, M14
Providing information	2	14, 28	M1, M4
Foster literacy skills	1	7, 14	M8
Foster social skills	1	7, 14	M2

## An Investigation of Parents' Habits of Reading Books

When Table 5 is reviewed regarding the aims of parents in reading to their children, it is noticed that seven of them aimed to foster language development, seven of them focused on improving imaginations, five of them underlined fostering cognitive development, five of them aimed to gain habit and like for reading, three of them considered going to sleep easily, two of them focused on informative, one of them aimed fostering literacy skills and one of aimed to foster social skills. Some of the responses are given below:

*"I generally read to help him improve his imagination. I read a lot myself, I always have a book in my hand. I want them to have the same habit." (M3); "So they can get information that is why." (M4); "To help his language development, so his imagination improves, he likes listening to stories before sleep, he relaxes. Sleeps easily." (M6); "First of all, to help him gain reading habit. Gain listening skill. Improve his understanding and imagination." (M11)*

### 9. Features parents consider when choosing books for their children

Parents were asked which features they consider while choosing books for their children and the responses formed these sub-themes: content features, physical features, appropriateness for age and interest, and author. The percentage and frequency values regarding the sub-themes are shown in the table.

**Table 6. Features parents consider when choosing books for their children**

Sub-theme	Frequency	Percentage	Participants
Content features	9	64, 28	M2, M5, M6, M8, M9, M10, M11, M12, M13
Physical features	4	28, 57	M6, M8, M12, M14
Appropriateness for age and interest of the child	9	64, 28	M1, M4, M5, M7, M9, M10, M11, M12, M13
Authors of the book	2	14, 28	M3, M8

When Table 6 is reviewed for which features parents consider in choosing books, it was found that nine of them considered book's content features, nine of them considered appropriateness for the age and interest of the children, four considered book's physical features, and two of them considered the authors of the book. Participant responses regarding this theme are as follows:

*"I pay attention to the things my child can understand."(M1); "I generally consider that it has Turkish authors." (M3); "We pay attention to the writings and pictures. I quickly scan the content in case there is anything bad. I consider that they are foreign. I like their visuals more. I, firstly, buy foreign authors." (M8).*

### 10. Content features parents consider when selecting books for their children

In the interviews, parents were asked which content features they consider while selecting books for their children and their responses were organized under the following sub-themes: superhero features, teaching values and positive behaviour, appropriateness for age and interest, ends happily, being educational, improves imagination, fosters problem-solving skills and content is not relevant. The percentage and frequency values for the sub-themes are given in the table below.

**Table.7. Content features parent consider when selecting books for their children**

Sub-theme	Frequency	Percentage	Participants
Superhero features	5	35, 71	A1, A6, A7, A8, A9
Teaching values and positive behaviour	4	28, 57	A2, A6, A7, A12
Being appropriate to the child's age and interest	4	28, 57	A3, A4, A5, A7
Having a happy-ending	3	21, 42	A2, A5, A9
Being educational	3	21, 42	A7, A13, A14
Improving imagination	2	14, 28	A8, A9
Fostering problem-solving skills	1	7, 14	A11
I don't pay attention to the content	1	7, 14	A10

When the responses from Table 7 are reviewed, it was found that five of the parents consider main character's features, four of them considers teaching values and positive behaviour, four of them consider that it is appropriate for the age and interest of the child, three of them focuses on books with happy endings, three of them being educational, two of them improving imagination, one of them problem-solving skills, and one of them said she doesn't pay attention to the content. Participants' responses to this theme are as follows:

*"He likes superheroes. I pay attention that it has superheroes. I'm not very optimistic about bad characters, so I read books with good characters more." (M1); "I pay attention to things that will interest her. So she would read without getting bored or she wouldn't say mommy, enough I'm bored." (M3); "I consider the pictures as he mostly looks at them to see if there is anything he would like. For example, there was tin soldier; he was deeply affected by that so I didn't read it again. His foot was shot by a soldier. He kept asking if the character was dead all the time, I regret ever reading it. I try to choose happy endings. He is deeply affected." (M5); "I generally try to choose books that would offer solutions to everyday problems." (M11).*

### 11. Physical features parents consider when selecting books for their children

Parents were asked about which physical features they consider while selecting books for their children and the responses formed the following sub-themes: appropriateness for age, print quality, visual features/picturing, dimension, thickness and hardness of the cover, text-visual relation. The percentage and frequency values regarding the sub-themes are shown in the table.

**Table.8. Physical features parents consider when selecting books for their children**

Sub-theme	Frequency	Percentage	Participants
Appropriateness for age	1	7, 14	M1
Print quality	3	21, 42	M2, M8, M9
Visual features/picturing	13	92, 85	M2, M3, M4, M5, M6, M7, M8, M9, M10, M11, M12, M13, M14
Dimension	6	42, 85	M2, M6, M9, M11, M12
Thick and hard cover	3	21, 42	M7, M8, M9
Text-visual relation	3	21, 42	M7, M9, M11

When Table 8 is examined for the physical features considered by the parent while selecting books for their children, it was noticed that thirteen parents consider visual features/picturing, six of them consider dimension, three of them the thick and hard cover, three of them the text-visual relation, three of the print quality and one of the appropriateness for age. Participants' responses for this theme are as follows:

*"Not really the dimension but being colourful to catch attention. I pay more attention to visual features." (M3); "I pay attention to the dimension. So it would attract more visual attention. That it is not exaggerated." (M6); "I pay attention that the cover is hard. The print is high-quality. I pay attention that it would not be spoiled in short time. Picturing is important. I pay attention that it has drawings that would improve visual perception." (M8).*

### 12. Activities parents do to help children gain reading habit

During the individual interviews, parents were asked what kind of activities they do to help their children gain the habit of reading and their responses formulated these sub-themes: reading to the child, being a model to the child by reading/organizing reading hour, going to bookshops/fairs, arranging a book corner so the child spends time with the books, creating/completing/telling stories through pictures, I don't do anything at the moment as the child doesn't know reading or writing and correct guidance of parents. The percentage and frequency values regarding the sub-themes are presented below.

**Table.9. Activities parents do to help their children gain reading habit**

Sub-theme	Frequency	Percentage	Participants
Reading to the child	5	35, 71	M4, M5, M6, M8, M10
Parent modelling reading/organizing reading hour	4	28, 57	M3, M7, M11, M14
Going to bookshops/fairs	2	14, 28	M7, M13
Arranging book corner so child can spend time with books	1	7, 14	M7
Creating/completing/telling stories through pictures	4	28, 57	M6, M9, M10, M12
I don't do anything because my child cannot read or write	1	7, 14	A1
Correct guidance of parents	1	7, 14	A2

When Table 9 is reviewed regarding the activities parents do to help their children gain reading habit, it is seen that five of them read to their children, four of them become a model by reading/organizes reading hour, four of them create/complete/tell stories through pictures, two of them goes to bookshops/fairs, one of them doesn't do anything because the child cannot read or write at the moment, one of them arranges a book corner so the child can spend time with the books, one of them implements correct guidance of parents. Participants' responses regarding this theme as follows:

*"I'm not doing anything at the moment because he doesn't know how to read or write but in future, we can select books we can look at and he can read." (M1); "There is no chance for children at this age not to like books. As long as the parents provide correct guidance." (M2); "Sometimes we read books together as a family. We have reading hours." (M3); "Telling fairy tales, creating stories. She loves drawing and turning them into stories. She draws on her own and then we turn it into a story together. Or, I give her a book she doesn't know and she tells me the story by looking at the pictures, it helps both to improve imagination and improves interpreting pictures." (M9); "Generally, I take him to fairs. I take him to various bookshops. I enable him to choose on his own." (M13)*

#### 4. Discussion and Conclusion

The study aims to investigate parents' reading habit to their pre-school aged children and their criteria for selecting children's books. In scope of this aim, the following aspects have been examined: parents' case of reading to their children, the age range they started reading to their children, their frequency of reading to their children, which parent mostly reads to the child, parents' views on who selects the book to be read to the child, parents' case of going to the library with their children, case of having a library that belongs to the child, parents' aims in reading to their children, the features parents consider while selecting books for their children and the activities parents do to help children gain reading habit. The collected findings showed that the age range parents start reading to their children is mostly 36-48 months and majority of the parents read to their children every day, however, it is mostly mothers who read to the children. In another study conducted by Kalaycioglu (2012), it was found that parents read almost every day to children at the 36-72 months. In Yilmaz's (2004) study, the rate of mothers reading to their children is 20,6% while the rate for fathers is 5,2% and that majority of the fathers (70,9%) do not read to their children during pre-school stage.

Another significant finding of the study is that majority of the parents do not have the habit of going to the library with their children and there is no library that belongs to children at home. In a study conducted by Cakmak and Yilmaz (2009), it was determined that majority of children (76%) have never been to the library with their parents. In another study by Yilmaz (2004), it was observed that majority of students (70,3%) do not own a library or bookshelf in their homes. Additionally, the study revealed that parents read to their children mostly to foster language and cognitive development and their imagination; that they consider visual features while selecting books; however, they do not pay adequate attention to the appropriateness of the books for the age and interest of the child. In Sackesen's (2008) study, it was found that parents' level of education and their profession and level of income influence their criteria for selecting books, while primary school graduates consider the

external look of the book while parents with higher education and income levels pay attention to content, topic and theme features. Similarly, Akgün (2003) found in his study that there is a significant difference in book buying behaviour of parents based on their level of income, and that as the monthly income raises the behaviour of buying books also increases.

When the activities parents do to help their children gain reading habit are reviewed in the study, it is observed that parents do not spend enough time to read with their children as well as going to the bookshops or book fairs with them. Cakmak and Yılmaz (2009) found in their study that majority of the parents (82%) do not take their children to book fairs while more than half of the parents (68%) take their children to bookshops and enable children's interaction with books in such settings. Children gain of reading habit is closely related with the efforts of parents, teachers and mass communication tools. The crucial points in gaining this habit are encouraging children to read and distinguish quality books (Cilgin, 2007). Parents are responsible for providing guidance to help their children know the books and be interested in them. It helps parents to be knowledgeable about child development and literature when the child asks questions about the book and when faced with the book (Cakmak Güleç & Geçgel, 2005). Parent reading together with their children is especially important for both establishing a physical and emotional bond between parents and children as well as being a role model for children. Apart from this, parents can visit libraries or book fairs with their children, organize reading workshops, review and children's literature books together so children can gain reading habit (Kurulgan and Cekerol, 2008; Fletcher et al., 2010; Durmusoglu, 2013).

Parent need to know their children well, determine their interests and levels and foster their development with correctly selected books. The book to be given to the child, just like a toy, should catch his interest. At early stages, books can be introduced as toys. It should be remembered in selecting books that children have individual differences. It is needed to consider the process of child associating with the characters in the book. The visuals, language and content used in a book should be appropriate for the child's age and developmental stage. The selected children's literature works should respect science and art, question and discuss issues so that they would contribute to raising sensitive individuals with improved book and reading culture (Tanju, 2010; Beyazıt and Butun Ayhan, 2016).

## References

- Akgün, S. (2003). *Ailelerin anassınıfına devam eden alti yas grubundaki çocuklarına kitap alırken göz onunde bulundurdıkları özelliklerin incelenmesi*. [An examination of the features that parents take into consideration when buying book for their 6 year old children]. (Unpublished master thesis) Hacettepe University, Ankara, Turkey.
- Balci, A. (2009). İlköğretim 8. sınıf öğrencilerinin kitap okuma alışkanlığına yönelik tutumları. [The attitudes of elementary school 8<sup>th</sup> grade students towards reading]. *Mustafa Kemal Üniversitesi Sosyal Bilimler Enstitüsü Dergisi*, [Journal of Mustafa Kemal University Social Sciences Institute], 6(11): 265-300.
- Balci, A., Uyar, Y. & Büyükkız, K. K. (2012). İlköğretim 6. sınıf öğrencilerinin okuma alışkanlıkları, kütüphane kullanma sıklıkları ve okumaya yönelik tutumlarının incelenmesi. [An examination of the elementary school 6<sup>th</sup> grade students' reading habits and attitudes towards reading]. *International Periodical For The Languages, Literature And History Of Turkish Or Turkic* 7/4: 965-985.
- Bamberger, R. (1990). *Developing reading habit*. 1st edition., Publishing of Ministry of Culture.
- Beyazıt, U. ve Butun Ayhan, A. (2016). Çocuk edebiyatı ve aile. [Child literature and Family]. *Çocuk Edebiyatı ve Medya* içinde [in Child Literature and Media] (Edit.: Serap Erdoğan, Meral Ören), p. 154-177. Eskişehir: Publishing of Anatolian University.
- Butun Ayhan, A., Simsek, S., & Bicer, A. M. (2014). An analysis of children's attitudes towards reading habits. *European Journal of Research on Education, Special Issue: Contemporary Studies in Education*, 13-18.
- Cakmak Güleç, H. ve Geçgel, H. (2005). *Çocuk edebiyatı. Okul öncesinde edebiyat ve kitap*. [Child literature. Literature and book in preschool period]. Ankara: Kök Publishing.
- Cakmak, T., & Yılmaz, B. (2009). A Research About the Reading Habit Readiness Situations of Preschool Children: Hacettepe University Beytepe Preschool Sample. *Türk Kütüphaneciliği*, 23, 3, 489-509.

- Cilgin, A. S. (2007). *Çocuk edebiyatı*. [Child literature]. İstanbul: Morpa Publishing.
- Dreher, M. J. (2002). Teaching ideas. *The Teaching Teacher*, 56(4), 338-344.
- Durmusoglu, M. C. (2013). Çocuklarda kitap sevgisi ve okuma alışkanlığı geliştirmenin bilişsel gelişime katkıları. [The contribution of reading books to cognitive development in children] *Cito Eğitim: Kuram ve Uygulama*, [Theory and Practice], 21, 17-24.
- Durualp, E., Çiçekoglu, P. & Durualp, E. (2013). Sekizinci sınıf öğrencilerinin kitap okumaya yönelik tutumlarının internet ve kitap okuma alışkanlıkları açısından incelenmesi. [An examination of children's reading habits in terms of their internet reading habits]. *Uluslararası Türkçe Edebiyat Kültür Eğitim Dergisi*, [International Turkish Literature Culture Education Journal], 2(1): 115-132.
- Fletcher, J., Greenwood, J. ve Parkhill, F. (2010). Are schools meeting their clients' expectations? Parents voice their perceptions about children learning to read in schools today. *Teaching and Teacher Education*, 26, 438-446.
- Hughes-Hassell, S., & Rodge, P. (2007). The leisure reading habits of urban adolescents. *Journal Of Adolescent & Adult Literacy*, 51(1), 22-33.
- Isikoglu Erdogan, N. (2015). Erken çocukluk döneminde çocuk-ebeveyn birlikte okuma etkinliklerinin incelenmesi. [Examination of the child-parents reading activities]. *Kastamonu Eğitim Dergisi*, [Kastamonu Education Journal], 24(3), 1071-1086.
- Johnson-Smaragdi, U., & Jonsson, A. (2006). Book reading in leisure time: long-term changes in young peoples' book reading habits. *Scandinavian Journal Of Educational Research*, 50(5), 519-540.
- Kakirman Yildiz, A. (2016). Okul öncesi dönem çocuklarının okuma alışkanlığı kazanmasında rol model olarak aile, [Parents as role models in children's acquisition of reading habits]. *Mavi Atlas*, (7), 95-112.
- Kakirman Yildiz, A. (2017). Okul öncesi dönem çocuğunun eğitim ve gelişiminde kitabın rolü ve bu süreçte anaokulu kütüphanelerinin gerekliliği, [The role of the books in the education and development of the preschool children and the necessity of the libraries in this procedure]. *International Journal of Social Sciences and Education Research*, 3(3), 792-802.
- Kalaycioglu, A. (2012). 36-72 aylık Türk ve yabancı çocukların ebeveyn ve öğretmenlerinin resimli çocuk kitabı seçme ölçütlerinin incelenmesi. [The examination of the teachers' and parents' of Turkish and foreigner children criteria of choosing children's books], (Unpublished master thesis), Hacettepe University, Ankara.
- Kurulgan, M., & Çekerol, S. (2008). Öğrencilerin okuma ve kütüphane kullanma alışkanlıkları üzerine bir araştırma, [A study on the students' habits of reading and going to library]. *Anadolu Üniversitesi Sosyal Bilimler Dergisi*, [Journal of Anatolian University Social Sciences Institute], 8(2), 237-258.
- Ozturk, S. D., & Aksoy, E. (2016). İlköğretim öğrencilerinin okuma alışkanlığına ilişkin veli görüşleri, [The thoughts of the parents on the reading habits of elementary school students]. *Abant İzzet Baysal Üniversitesi Eğitim Fakültesi Dergisi*, [Journal of Abant İzzet Baysal University Faculty of Education], 16(2), 562-591.
- Sackesen, S. (2008). *Cocuk kitapları seciminde anne babaların ve okul öncesi öğretmenlerinin görüşlerinin incelenmesi*. [The examination of the parents' and teachers's thoughts on choosing child books]. (Unpublished master thesis), Gazi University, Ankara.
- Sangkaeo, S. (1999). Promoting the lifetime reading habit in middle school students. *The Clearing House*, 73(3), 157-161.
- Sever, S. (2008). *Çocuk ve edebiyat*, [Child and literature]. İzmir: Tudem Publishing.
- Sahin, A. (2012). İlköğretim 4 ve 5. sınıf öğrencilerinin kitap okuma alışkanlıklarının sosyo-ekonomik düzeylerine göre incelenmesi, [The examination 4<sup>th</sup> and 5<sup>th</sup> grade students reading habits according to their socio-economic level]. *Türk Eğitim Bilimleri Dergisi*, [Journal of Turkish Educational Sciences], 10(2), 367-388.
- Sahin, E. Y., Celik, G., & Celik, B. (2012). Anne-babaların çocuk edebiyatı kavramına ilişkin görüşleri (Canakkale örneği), [Parents' thoughts related to the concepts of child literature]. *Çanakkale Araştırmaları Türk Yılığ*, [The Turkish Annual of Canakkale Researches], 10(12), 109-125.
- Tanju, E. H. (2010). Çocuklarda kitap okuma alışkanlığına genel bir bakış. [A general look at the children's reading habits] *Aile ve Toplum*, [Family and Society], Nisan - Mayıs - Haziran, 31-39.



- Tezel Sahin, F., & Tutkun, C. (2016). Okul oncesi dönemde anne, baba, çocuk ve kitap, [Mother, father, child and book in preschool period]. *Kastamonu Eğitim Dergisi*, [Kastamonu Education Journal], 24(5), 2373
- Yildiz Bicakci, M., Er, S., & Aral, N. (2018). Etkilesimli oyku kitabi okuma sürecinin çocukların dil gelişimi üzerine etkisi, [The effect of interactive reading of story books on the language development of the children]. *Kastamonu Eğitim Dergisi*, [Kastamonu Education Journal], 26(1), 201-208.
- Yilmaz, B. (2004). Öğrencilerin okuma ve kütüphane kullanma alışkanlıklarında ebeveynlerin duyarlılığı, [The parents' sensitivity about students' habits of reading and going to library]. *Bilgi Dünyası*, [World of Knowledge], 5(2), 115-136.