

# ID11- SMART SENSING INTEROPERABILITY PLATFORMS IN THE SCOPE OF ATLANTOS

DANIEL A. REAL-ARCE<sup>116</sup>, EHSAN ABDI<sup>35</sup>, ENOC MARTÍNEZ<sup>145</sup>, E. DELORY<sup>117</sup>, C. BARRERA<sup>118</sup>, J. HERNÁNDEZ<sup>119</sup>  
AND O. LLINÁS<sup>120</sup>

## Abstract

This paper aims to demonstrate the capabilities of a Smart Cable which aims to convert any commercial non-PUCK-enabled sensor in a Smart PUCK-enabled device. Through this development, it can be easily integrated on a sensor web platform in order to access the data in real time, and so there is no need to rely on each sensor manufacturer to comply with Sensor Web Enablement standards. The results presented in this paper were acquired during some real field experiments performed between the 24th and 28th of September at PLOCAN facilities in Gran Canaria. During these days three Turner Designs Cyclops sensors were successfully integrated and tested in a mission using an observing surface vehicle such as the Wave Glider SV-2.

*Key words:* ASV, unmanned vehicle, sensors, communication, cable

## INTRODUCTION

The presented work is done in the framework of H2020 AtlantOS EU- Project. AtlantOS is a BG 8 (Developing in-situ Atlantic Ocean Observations for a better management and sustainable exploitation of the maritime resources) for the integration of ocean observing activities across all disciplines for the Atlantic, considering European partners as well as non-European participants.

The overall goal of this project is to improve ocean-observations capacity in the area of interest by using cutting-edge technologies in a cooperative and synergistic way between partners from different disciplines of the marine and maritime sector, by using new and existing resources provided by ongoing projects and initiatives at regional, national and international level, in order to cover the widest number of specific and common needs and requirements from each one of them, as well as additional potential stakeholders.

In this sense some demonstrative initiatives have taken place in PLOCAN facilities in the scope of AtlantOS. The one presented in this paper comprises the Cyprus Subsea company, creator of the Smart Cable used during the experiment, and coordinator of the H2020 project Bridges, and the UPC which was one of the partners of FP7 Nexos project involved in the creation of the web data viewer used – SOS viewer.

## EXPERIMENT

The sensors integrated and demonstrated in this experiment are commercial optical sensors that measures turbidity, chlorophyll and refined fuels. Each of these three sensors are connected aboard the Wave Glider with a dedicated developed Smart Cable (Fig. 1) to a SensorML compatible device on board.

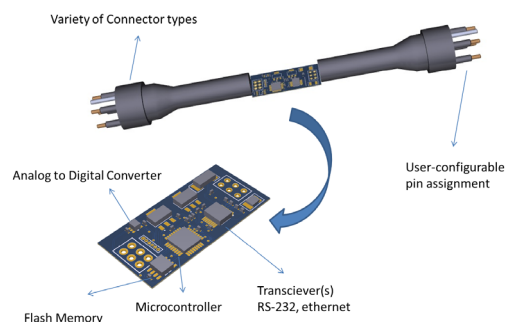

**Fig. 1 Smart Cable from Cyprus Subsea**

In this experiment the OGC PUCK protocol will be used to retrieve a SensorML file from the Smart Cable connected to a sensor. The SensorML is then parsed by the platform and a plug-and-work sensor integration shall be demonstrated. Additionally, the data from sensors shall be made available on a web client in real-time through a SOS server. Using this development any sensor can be turned into a plug-and-work interoperable device as it stores and provides SensorML files.

## RESULTS

The results of this experiment were retrieved during a 24h mission where the three sensors installed in the Wave Glider were acquiring data that could be seen through the AtlantOS SOS interface in real time (Fig. 2) via an Iridium link.

## ACKNOWLEDGEMENT

The ATLANTOS Project has received funding from the European Union's Horizon 2020 research and innovation programme under grant agreement 633211.



**Fig. 2 Sensors installed in the Wave Glider / Data received in real time to the SOS interface**