

**1.25 - 2.5 Gb/s Simple Nyquist Transmitters for Coherent UDWDM-PON with Enhanced Spectral Efficiency**

Journal:	<i>Fiber and Integrated Optics</i>
Manuscript ID	UFIO-2018-2188.R2
Manuscript Type:	Original Article
Keywords:	beat phase modulation, DFB, Nyquist shaping, UDWDM-PON, coherent detection

SCHOLARONE™  
Manuscripts

## 1.25 - 2.5 Gb/s Simple Nyquist Transmitters for Coherent UDWDM-PON with Enhanced Spectral Efficiency

A coherent ultra-dense wavelength division multiplexing passive optical network (UDWDM-PON) with high spectral efficiency is experimentally tested. The transmitters consist of directly phase modulated distributed feedback (DFB) lasers through beat signals whose duty-cycle and amplitude are digitally adjusted. The benefit of using Gaussian or Nyquist pulse-shaping filters at the transmitter is evaluated through numerical simulations and experiments. The results show that transmitting a Nyquist-shaped signal achieves a 25% spectral saving allowing to place 2.5 Gb/s/user data in 6.25 GHz channels. The proposed transmitter tolerates differential link-losses of 15 dB with Rx sensitivity of -44 dBm at BER= $10^{-3}$  with intradyne detection.

**Keywords:** beat phase modulation, DFB, directly modulated laser (DML), Nyquist shaping, UDWDM-PON, coherent detection.

### 1. Introduction

Motivated by the need of high spectral efficiency and aggregated capacity, coherent ultra-dense wavelength division multiplexing (UDWDM) solutions have gained interest [1, 2]. These systems are attractive because they can inherently filter the optical signal by selecting the wavelength, and provide higher sensitivities compared with direct detection thus avoiding optical amplifiers [3]. However, for the competitive access market, low complexity transceivers with simplified digital signal processing (DSP) need to be designed while keeping high the performance [4].

In UDWDM-PON, a major concern is the unwanted spectral side-lobes resulting when modulating the optical carrier. Since the frequency grid is very narrow, these spectral components cause interference to adjacent channels, yielding to Bit Error Rate (BER) degradation. The use of spectral shaping filtering at the transmitter (Tx) thus can play an important role reducing the modulated spectral width and suppressing interference from adjacent channels [5]. As a result, it can improve the network spectral efficiency as demonstrated in [6]. However, in [6] the Tx was highly complex because of using an external modulator.

In previous work, we proposed direct phase modulation of a distributed feedback (DFB) laser for simplifying the Tx. The modulating data was coded and had three levels. In addition, its amplitude and duty cycle (d-c) were digitally adjusted to achieve the phase variations [7]. In this paper, we analyze the benefit of using Gaussian or Nyquist shaping filters in the Tx to increase the spectral efficiency, extending the results of [8]. We first do an evaluation through numerical simulations. Then we present the experimental validation in an UDWDM-PON. This is, to the best of our knowledge, the first simple directly phase modulated Tx with spectral confinement for a coherent UDWDM-PON. At the receiver (Rx), an intradyne detector recovered the data achieving sensitivity values of -49 dBm and -44 dBm for bitrates ( $R_b$ ) of 1.25 Gb/s and 2.5 Gb/s respectively at BER of  $10^{-3}$ . Furthermore, sensitivity penalties  $< 1$  dB are observed in channels separated only by 6.25 GHz and tolerating a differential link-loss of 15 dB [9].

### 2. Numerical Simulations

The simulations were performed with VPITransmissionMaker® and MATLAB® following the Monte-Carlo method. The simulation setup was composed of two users with Tx consisting of an ideal phase modulator (PM) which generated a 0 - 180° phase shift keying (PSK) signal. Both users were combined in a 3dB optical coupler as presented in Figure 1a.

The modulating data was a  $2^{15}-1$  Pseudo Random Binary Sequence (PRBS) differentially encoded at  $R_b$  of 1.25 Gb/s with rise-time  $t_r = 0.1T_b$ , where  $T_b$  is the bit period.

Additional electrical filtering was applied to data before optical modulation to modify the dynamics of the electrical pulses and shaping its spectrum.

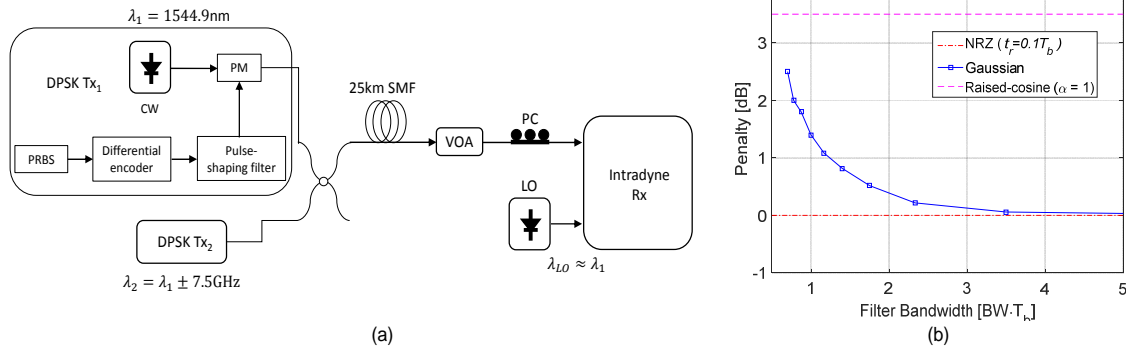

Figure 1. (a) Simulation Setup. (b) Sensitivity penalty @BER= $10^{-3}$  vs normalized filter BW for the three pulse-shaping schemes.

We considered two shaping filter types: Gaussian and Raised-cosine. In the first one, the sharp symbol transitions were smoothed to Gaussian dynamics with a rise-time  $t_r$  depending on the 3-dB filter bandwidth (BW) calculated as  $BW = 0.35/t_r$ . On the second hand, the Raised-cosine adjusted the excess filter BW beyond the Nyquist BW:  $1/2T_b$ . The parameter that defined the filter was the roll-off ( $\alpha$ ) which ranged between 0 and 1. For this shaping technique, the lower  $\alpha$ , the lower the total filter BW and the higher spectral compression. The filter BW was expressed as:  $BW = (1 + \alpha) R_b/2$ .

The optical power of each generated differential PSK (DPSK) signal was set to 0 dBm and launched through 25 km of single-mode fiber (SMF). Then a variable optical attenuator (VOA) emulated further splitting and adjusted the power at the Rx. The state of polarization (SOP) of the transmitted signal was matched with that of the local oscillator (LO) by means of a polarization controller (PC). The signal was detected with a coherent intradyne Rx based on a 3x3 optical coupler [10].

In order to find the optimal parameters ( $B_w$  and  $\alpha$ ) for the shaping filters, we set the input power at Rx at the value that produced BER =  $10^{-3}$  for Non-return-to-zero (NRZ) format. Then, we computed the power penalty due to the Gaussian filter BW. The results are shown in Figure 1b. A power penalty larger than 1 dB was observed for  $BW < 1.2/T_b$ . Therefore, the Gaussian filter was set at  $BW = 1.2/T_b$  (corresponding to  $t_r = 0.29T_b$ ). For the Raised-cosine filter, the power penalty at maximum bandwidth  $BW = 1/T_b$  (corresponding to  $\alpha = 1$ ) was 3.5 dB.

Figure 2 depicts the original NRZ electrical spectrum before and after the filters. In the NRZ signal, we observe that the sharp transitions between symbols result in high-frequency harmonic components. There is significant power beyond 1.25 GHz and the main to secondary spectral lobes power suppression (MSPS) is 14dB. With electrical Gaussian filtering, the symbol transitions are smoothed and the MSPS is 18 dB. When using the Raised-cosine filter, the electrical pulses are sinc-shaped and ideally exhibit a square spectrum. As seen in Figure 2, the MSPS is >60 dB.

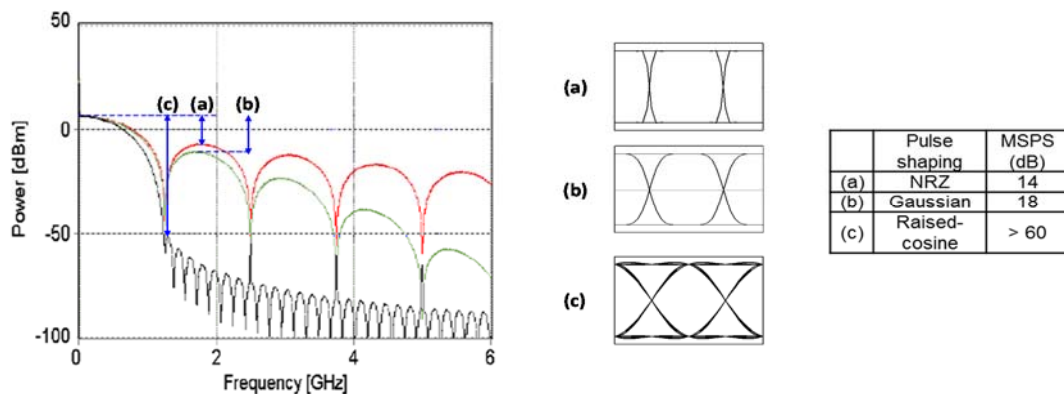

Figure 2. Electrical spectra of 1.25 Gb/s PRBS data and eye diagrams for each case: (a) NRZ, (b) Gaussian, (c) Raised-cosine pulse shaping at the Tx.

A second user was added into the network with identical pulse shaping. Figure 3 plots the optical spectra of both channels separated 6.25 GHz. The NRZ, Gaussian shaped and Raised-cosine filtered signals show an MSPS of 12 dB, 13 dB and 19 dB respectively. The latter thus is expected to reduce the channel spectral separation. It is interesting to note that the optical MSPS values are lower than the electrical because of the non-linear characteristic of the phase modulation. This produced strong Bessel harmonic components in the optical domain.

Next, the minimum channel spacing was evaluated. For this, the second user optical frequency was shifted from -7.5 GHz to 7.5 GHz with respect to the other user emission frequency. The BER degradation was measured in the fixed user (Figure 4a). These values were translated into power penalty at a sensitivity of  $\text{BER}=10^{-3}$  considering the single channel as reference (Figure 4b). The values at 1 dB penalty were 2.8 GHz, 2.2 GHz and 1.8 GHz for NRZ, Gaussian and Raised-cosine pulse-shaping respectively. Notably, there was no penalty at a 6.25 GHz spacing and even less than 2.5 GHz could be achieved when shaping the pulse.

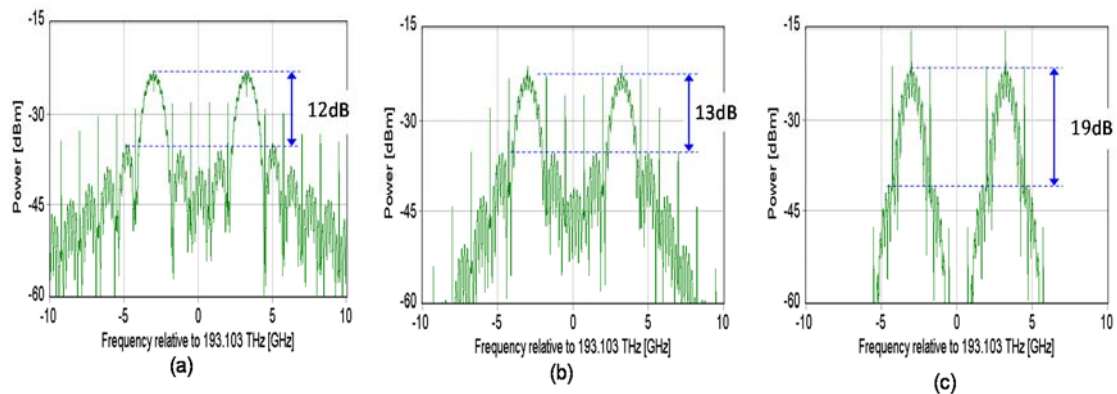

Figure 3. Optical spectra for two users separated by 6.25 GHz for three different pulse-shaping schemes: (a) NRZ, (b) Gaussian, (c) Raised-cosine.

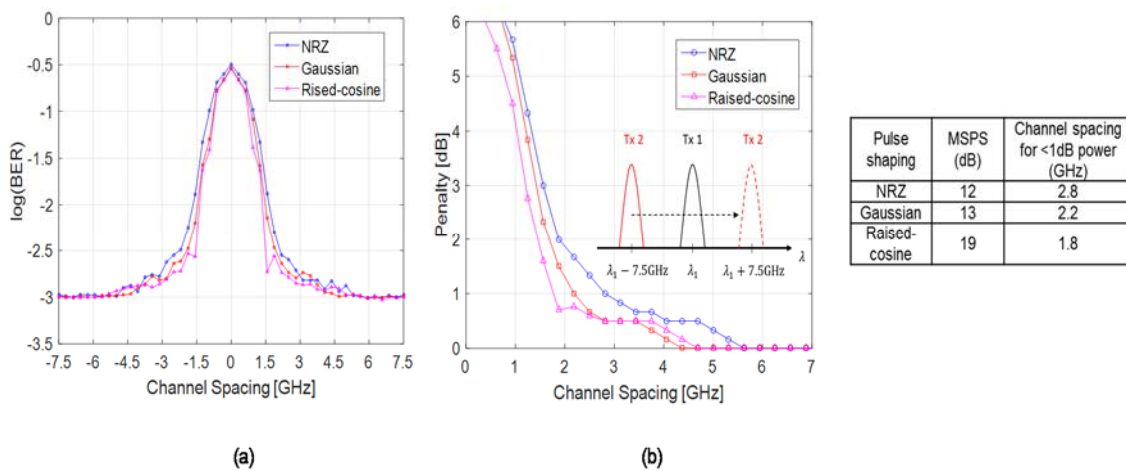

Figure 4. (a) BER against Channel Spacing for  $\text{Tx}_1$  using three different pulse-shaping filters. (b) Sensitivity penalty @ $\text{BER}=10^{-3}$  for the three pulse-shaping schemes.

### 3. Experimental setup

Once the technique was evaluated through simulations, we implemented the **UDWDM-PON** scenario depicted in Figure 5. The setup was composed by two identical transmitters ( $\text{Tx}_1$  and  $\text{Tx}_2$ ) based on direct modulated DFBs with linewidths of 4 MHz and 3 MHz and modulation BW of 10 GHz and 2.5 GHz respectively. The DFBs were biased at 75 mA, value at which we observed that the adiabatic chirp dominated.

The data consisted of two uncorrelated differentially encoded  $2^{15}-1$  Pseudo Random Binary Sequences (PRBS) at  $R_b$  of 1.25 Gb/s and 2.5 Gb/s. Each sequence modulated a separate DFB. The data sequences were digitally equalized by means of a 1-tap finite impulse response (FIR) filter with half-bit period delay. The result was a Dicode Return-to-zero (Dicode RZ) signal whose duty-cycle was adjusted to 50%. Then, its spectrum was shaped with a Raised-cosine FIR filter of 64-taps. The resulting samples were uploaded to a 20 GSa/s arbitrary waveform generator (AWG). The outputs were amplified with an 8 GHz (SHF98P) and 12 GHz (TBI-781) BW electrical amplifiers for  $Tx_1$  and  $Tx_2$  respectively. The waveform amplitude was optimized to ensure  $0-\pi$  phase changes when directly modulating the DFB and producing, as a result, optical DPSK signals [7]. The optical signals were combined with a 3-dB optical coupler and sent through 25 km of single mode fibre (SMF) with a launched power of 0 dBm. A variable optical attenuator (VOA) reproduced splitting losses and limited the power into the Rx.

The Rx consisted of an intradyne detector based on a 3x3 optical coupler which mixed the incoming optical signal with a LO. The latter was a 100 kHz linewidth external cavity laser (ECL) with 0 dBm optical power emitting at  $\lambda_{LO} = \lambda_1 = 1544.9$  nm. The three outputs of the optical coupler were detected with 10 GHz p-i-n- photodiodes (PDs) followed by low-noise electrical amplifiers. The electrical signals were low-pass filtered, sampled and processed with a 50 GSa/s real-time oscilloscope (RTO). The three currents were combined and processed to obtain the in-phase (I) and quadrature (Q) parts as in [10]. Each component was then differentially demodulated with a bit-delay and multiply operation, and then both were added. Afterwards, the samples passed through a 4th order low-pass filter with  $R_b$  cut-off frequency and the BER was computed.

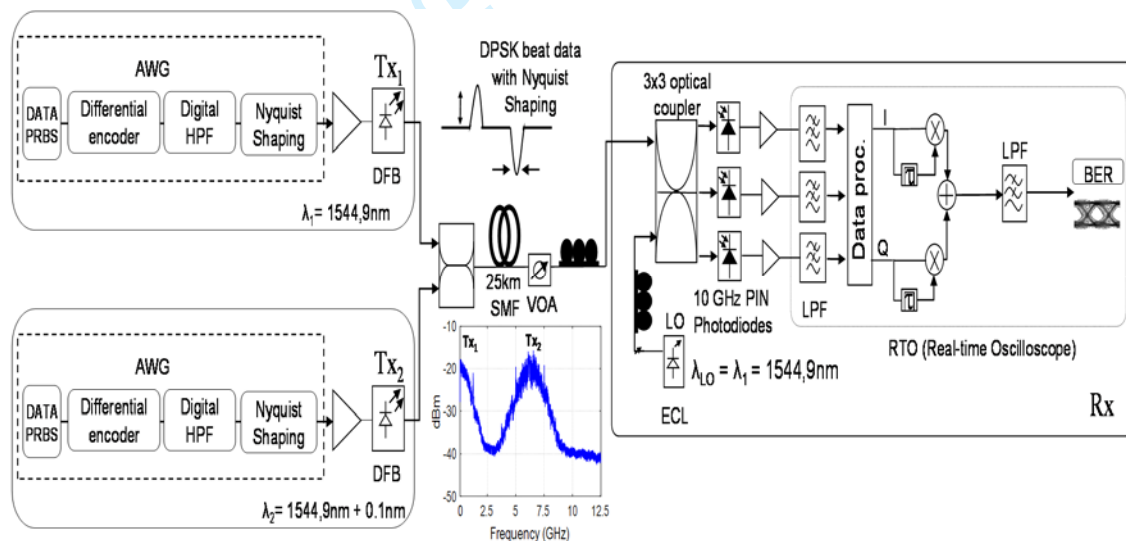

Figure 5. Experimental setup; the inset shows the data stream with Nyquist shaping and the RF spectra of both Txs spaced 6.25 GHz.

#### 4. Results

Two electrical signals, one with and another without Nyquist-shaping, were digitally generated. Figure 6a shows the electrical data at  $R_b = 1.25$  Gb/s along with the Nyquist shaped waveform for a roll-off factor ( $\alpha$ ) of 0.25 (upper) and 1 (lower). Figures 6b, 6c, 6d and 6e present the photo-detected spectra at a relative intermediate frequency (IF) of 10 GHz for signals at bitrates of 1.25 Gb/s and 2.5 Gb/s. We observe that the lateral lobes are eliminated, but the main lobe is not compacted as expected with externally modulated Txs [6]. This is because we are directly modulating the phase of the laser, which has nonlinear dynamics, and leads to harmonics due to the Bessel function solution. However, the BW of the residual intensity modulation (IM) is narrowed. This is particularly noticed for lower  $\alpha$  value. In contrast with PM, the IM residual term is generated with a linear modulation. Finally, we decided to use  $\alpha = 1$  since the effect of lower  $\alpha$  is barely perceived.

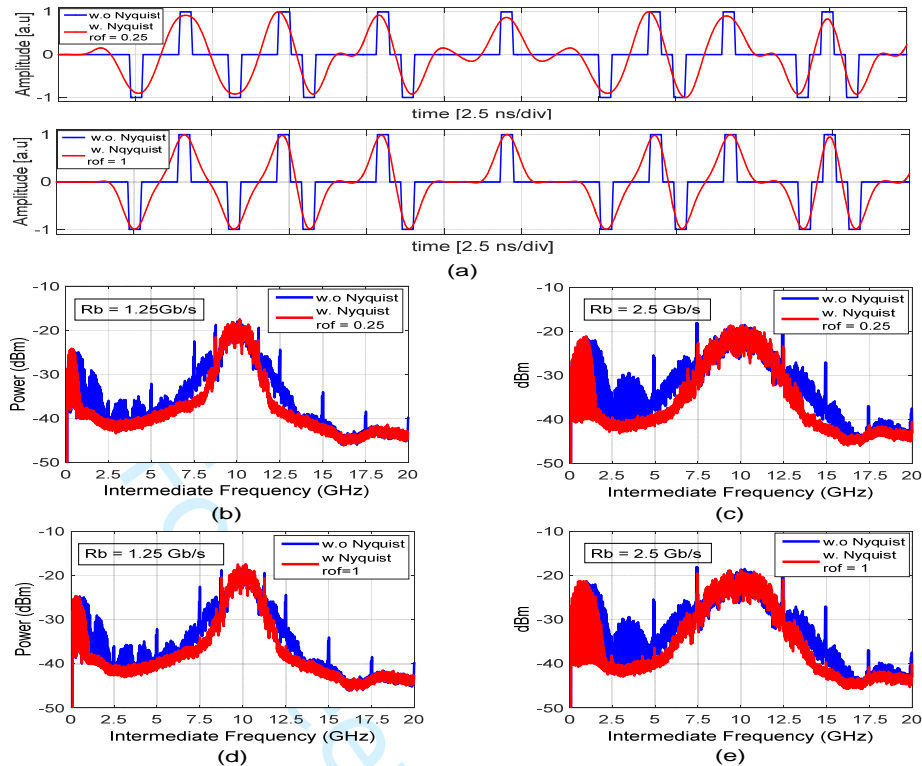

Figure. 6 (a) Electrical beat square signal and Nyquist shaped signal with  $\alpha = 0.25$  (upper) and  $\alpha = 1$  (bottom) and RF spectrum of the Tx signal without and with Nyquist shaping at  $R_b = 1.25$  Gb/s (b, d) and  $R_b = 2.5$  Gb/s (c, e) for  $\alpha = 0.25$  and  $\alpha = 1$ .

We firstly tested the system in point to point (ptp) with  $Tx_1$ . The amplitude of the electrical waveforms was optimized and the DFB laser was directly modulated at  $R_b$  of 1.25 Gb/s and 2.5 Gb/s. The BER curves are plotted in Figure 7a. The Rx sensitivities measured at a forward error correction (FEC) BER of  $10^{-3}$  were -52 dBm and -49.5 dBm respectively without Nyquist shaping. These values were approximately 3 to 5.5 dB better with respect to the obtained with Nyquist shaping (-49 dBm and -44 dBm for 1.25 Gb/s and 2.5 Gb/s correspondingly). The performance degradation is because the strong filtering introduces distortion, thus reducing the eye-opening at the Rx. This effect is clearly observed in the eye diagrams of Figures 7c and 7e where Nyquist-shaping was applied compared to Figures 7b and 7d at bitrates of 1.25 Gb/s and 2.5 Gb/s respectively. The use of a matched filter in the Rx can improve the eye-opening and thus the performance [6].

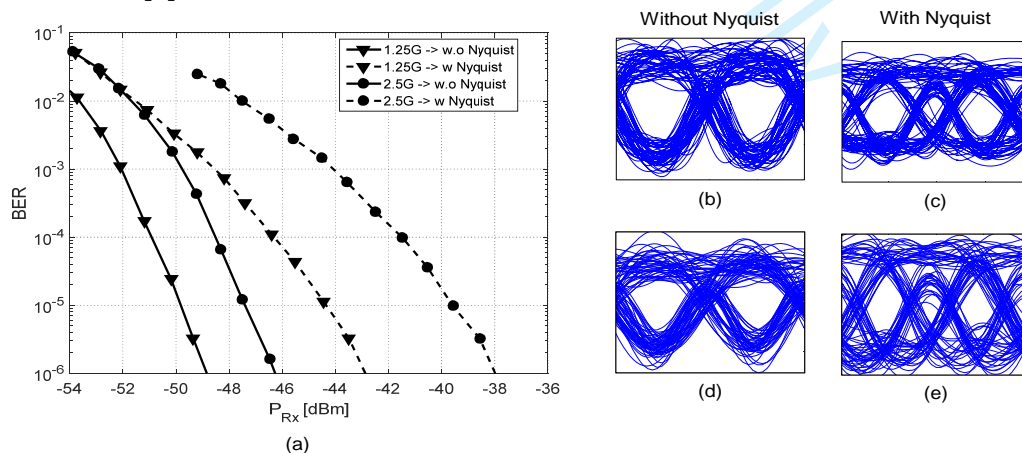

Figure. 7. (a) BER against Rx optical power for  $Tx_1$  and eye diagrams at  $BER = 3 \cdot 10^{-6}$  without and with Nyquist shaping at 1.25 Gb/s (b,c) and 2.5 Gb/s (d,e) respectively.

As the Nyquist shaped signals produced a lower optical BW, we evaluated the minimum spectral separation between users in the network. We added  $Tx_2$  and modulated it identically to  $Tx_1$ . Both  $Tx_1$  and  $Tx_2$  had the same launched power (0 dBm).  $Tx_2$  wavelength ( $\lambda_2$ ) was tuned in temperature and shifted in steps of 1.25 GHz from/to a spectral separation of  $\pm 12.5$  GHz. The Rx optical power was left constant at the value where  $BER \approx 2 \cdot 10^{-4}$  in ptp. Then, the performance of  $Tx_1$  was evaluated when  $Tx_2$  caused interference at different channel spacing (CS).

Figure 8a plots the BER against the CS with and without Nyquist shaping. For both signals the minimum CS to keep the penalty  $< 1$  dB (according to Figure. 7a) was similar: 3.125 GHz and 4.375 GHz at  $R_b = 1.25$  Gb/s and  $R_b = 2.5$  Gb/s respectively. Thus, there was no improvement in CS when using Nyquist shaping showing that beat signals already produce a confined spectrum.

We then studied the effect on CS when the optical signals had different power.  $Tx_2$  launched power was 15 dB higher than  $Tx_1$ , in order for the spectral side-lobes to become relevant. We repeated the CS measurements described in the previous paragraph with a differential link-loss (DLL) of 15 dB. Figure 8b show the BER against the CS at  $R_b = 1.25$  Gb/s and  $R_b = 2.5$  Gb/s for  $Tx_1$ .

For  $R_b = 1.25$  Gb/s, the CS needed to keep the penalty  $< 1$  dB was 5 GHz when no spectral shaping was employed. However, for the Nyquist filtered signal, the CS was just 3.75 GHz. Similarly, when doubling  $R_b$  to 2.5 Gb/s, the required CS were 6.25 GHz and 8.75 GHz, with and without Nyquist shaping respectively. For a  $DLL = 15$  dB, Nyquist shaped pulses gave an advantage and improved the CS by 25%. As a result, the Nyquist shaped Tx at both 1.25 Gb/s and 2.5 Gb/s could work in a 6.25 GHz spaced PON of  $DLL = 15$  dB.

With these results, we dimension the **UDWDM-PON** considering the PtP WDM wavelength band for NGPON2 (1603 nm – 1625 nm) [9] and the CS obtained with Nyquist shaping. The total ONUs that could potentially be served at 2.5 Gb/s/user is 440 ( $22 \text{ nm} \times (125 \text{ GHz}/1 \text{ nm}) = 2750 \text{ GHz}$ , and  $\#channels = 2750 \text{ GHz}/6.25 \text{ GHz} = 440$ ). The aggregated capacity then nearly reaches 1.1 Tb/s ( $400 \times 2.5 \text{ Gb/s}$ ).

However, it is important to consider the eye safety frontier (21.3 dBm [1]). With this value in mind, the emitted power per channel should be limited to only -6 dBm. Thus, the available link budget is 38 dB (-6dBm - (-44 dBm)), which allows splitting losses of 27 dB (for 1:512 optical splitter) and 55 km reach (Fiber attenuation = 0.2 dB/km) with a performance above the FEC threshold. Furthermore, the proposed system would allow a DLL of 15 dB with a maximum penalty of 1 dB.

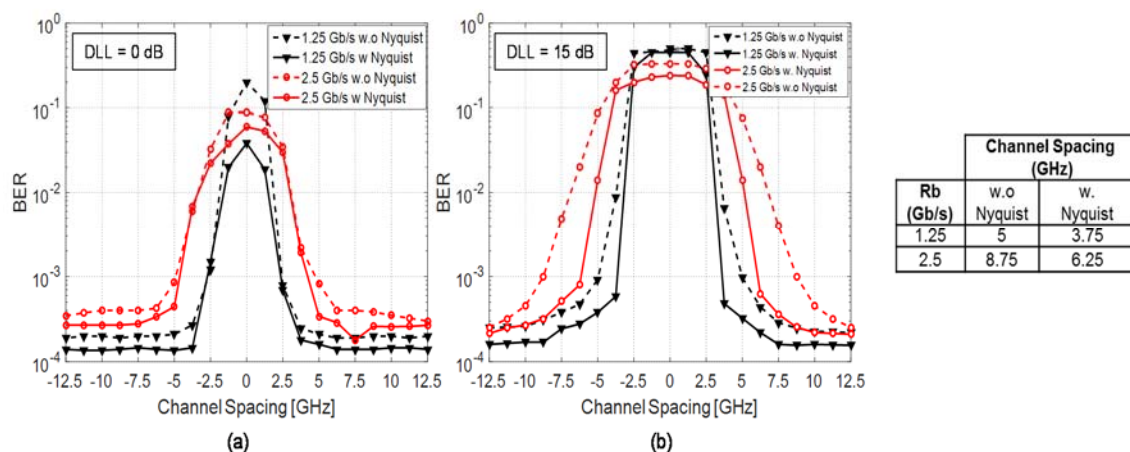

Figure 8. BER against channel spacing with and without Nyquist shaping for  $Tx_1$  at  $R_b = 1.25$  Gb/s and  $R_b = 2.5$  Gb/s for (a)  $DLL = 0$  dB and (b)  $DLL = 15$  dB.

## 5. Conclusions

In this work, we evaluated with numerical simulations and experimentally tested a direct phase modulated DFB laser at 1.25 Gb/s and 2.5 Gb/s with Nyquist shaped DPSK. A coherent UDWDM-PON was emulated with a 25 km SMF link and intradyne detection. We initially found that with a DLL of 0 dB, there was no significant benefit when using Nyquist shaping in the Rx sensitivity and CS. However, with a DLL of 15 dB, there was an improvement of 25 % in the spectral spacing allowing for a separation of just 6.25 GHz at a user speed of 2.5 Gb/s. Considering these values and the eye-safety limit, the UDWDM-PON could potentially serve 440 users for an aggregated bitrate of 1.1 Tb/s, and with an available link budget of 38 dB.

## Acknowledgements

This work was supported in part by the Spanish MINECO FLIPER project TEC2015-70835 and by the AGAUR under grant 2016FI\_B 00758.

## References

1. Prat, J., Cano, I. N., Presi, M., Tomkos, I., Klondis, D., Vall-llosera, G., Brenot, R., Pous, R., Papastergiou, G., Rafael A., and Ciaramella E. 2016. Technologies for a cost effective udWDM-PONs. *Journal of Lightwave Technology* 34(2): 783-791.
2. Agrell, E., Karlsson, M., Chraplyvy, A. R., Richardson, D. J., Krummrich, P. M., Winzer, P., Roberts, K., Fischer, J. K., Savory, S. J., Eggleton, B. J., Secondini, M., Kschischang, F. R., Lord, A., Prat, J., Tomkos, I., Bowers, J. E., Srinivasan, S., Brandt-Pearce M., and Gisin, N. 2016. Roadmap of optical communications. *Journal of Optics* 18(6): 1-40.
3. Kazovsky, L., Benedetto, S., and Willner, A. 1996. *Optical Fiber Communications Systems. Coherent Systems*. Artech House, pp 263-268.
4. Presi, M., Artiglia, M., Bottoni, F., Rannello, M., Cano, I. N., Tabares, J., Velásquez, J. C., Ghasemi, S., Polo, V., Chu G. Y., Prat, J., Azcarate, G., Pous, R., Vilá, C., Debregas, H., Vall-llosera, G., Rafael A., and Ciaramella E. 2016. Field-Trial of a High-Budget, Filterless,  $\lambda$ -to-the-User, UDWDM-PON Enabled by an Innovative Class of Low-Cost Coherent Transceivers. 2017. *Journal of Lightwave Technology* 35(23): 5250-5259.
5. Anandarajah, P., Barry L.P., and Kaszubowska, A. 2001. Cross-Channel Interference Due to Mode Partition Noise in WDM Optical Systems. Paper no We.A.2. Proceedings of the 3rd International Conference on Transparent Optical Networks, ICTON 2001, Cracow, Poland, June, pp 173-176.
6. Ferreira, R. M., Reis, J. D., Rossi, S. M., Amado, S. B., Guiomar, F. P., Shahpari, A., Oliveira, J. R., Pinto, A. N., Teixeira A. L. 2016. Coherent Nyquist UDWDM-PON with Digital Signal Processing. *Journal of Lightwave Technology* 34(2): 826-833.
7. Velásquez, J. C., Cano, I. N., Domingo, M., Polo, V., and Prat, J. 2017. 15-dB Differential Link-Loss UDWDM-PON with Direct Beat Phase Modulated DFBs. 2018. *IEEE Photonic Technology Letters* 30(2): 137-140.
8. Velásquez, J. C., Tabares, J., Cano, I. N., Polo, V., and Prat, J. 2017. Coherent Nyquist UDWDM-PON with 2.5 Gb/s/user and 15 dB Differential Link-Loss. 2017. *7<sup>th</sup> International Workshop on Fiber Optics Network (FOAN), Munich, Germany*.
9. ITU-T. 2014. 40-Gigabit-capable passive optical networks 2(NG-PON2): Physical media dependent (PMD) layer specification. Recommendation G.989.2, pp 13-15.
10. Xie, C., Winzer, P. J., Raybon, G., Gnauck, A. H., Zhu, B., Geisler, T., and Edvold, B. 2012. Colorless Coherent Receiver Using 3x3 Coupler Hybrids and Single-Ended Detection. *Optic Express* 20(2): 1164-1171.