

UNIVERSITY OF BIRMINGHAM

Research at Birmingham

Automotive surface identification system based on modular neural network architecture

Bystrov, Aleksandr; Hoare, Edward; Tran, Thuy-Yung; Clarke, Nigel; Gashinova, Marina; Cherniakov, Mikhail

DOI:

[10.23919/IRS.2017.8008124](https://doi.org/10.23919/IRS.2017.8008124)

License:

Other (please specify with Rights Statement)

Document Version

Peer reviewed version

Citation for published version (Harvard):

Bystrov, A, Hoare, E, Tran, T-Y, Clarke, N, Gashinova, M & Cherniakov, M 2017, Automotive surface identification system based on modular neural network architecture. in Radar Symposium (IRS), 2017 18th International. Radar Symposium (IRS), IEEE Xplore, Prague, Czech Republic.
<https://doi.org/10.23919/IRS.2017.8008124>

[Link to publication on Research at Birmingham portal](#)

Publisher Rights Statement:

© 2017 IEEE. Personal use of this material is permitted. Permission from IEEE must be obtained for all other uses, in any current or future media, including reprinting/republishing this material for advertising or promotional purposes, creating new collective works, for resale or redistribution to servers or lists, or reuse of any copyrighted component of this work in other works.

General rights

Unless a licence is specified above, all rights (including copyright and moral rights) in this document are retained by the authors and/or the copyright holders. The express permission of the copyright holder must be obtained for any use of this material other than for purposes permitted by law.

- Users may freely distribute the URL that is used to identify this publication.
- Users may download and/or print one copy of the publication from the University of Birmingham research portal for the purpose of private study or non-commercial research.
- User may use extracts from the document in line with the concept of 'fair dealing' under the Copyright, Designs and Patents Act 1988 (?)
- Users may not further distribute the material nor use it for the purposes of commercial gain.

Where a licence is displayed above, please note the terms and conditions of the licence govern your use of this document.

When citing, please reference the published version.

Take down policy

While the University of Birmingham exercises care and attention in making items available there are rare occasions when an item has been uploaded in error or has been deemed to be commercially or otherwise sensitive.

If you believe that this is the case for this document, please contact UBIRA@lists.bham.ac.uk providing details and we will remove access to the work immediately and investigate.

Automotive Surface Identification System Based on Modular Neural Network Architecture

Aleksandr Bystrov*, Edward Hoare*, Thuy-Yung Tran**, Nigel Clarke**,
Marina Gashinova*, Mikhail Cherniakov*

*University of Birmingham
Edgbaston, Birmingham, B15 2TT, UK
email: a.bystrov@bham.ac.uk

**Jaguar Land Rover Research Department
Coventry, CV3 4LF, UK
email: ttran3@jaguarlandrover.com

***Abstract:** The development of automotive remote surface identification system is an important step in ensuring road safety. In this paper we shall discuss a novel approach which addresses the road surface classification process. This method is based on polarimetric radar and sonar data fusion and surface identification using artificial neural network. A modular artificial neural network, which is considered in the paper, allows an overall increase in classification accuracy in the presence of a large number of surface types and a large number of signal features. We shall discuss the techniques involved and present classification results that have been achieved using modular neural network.*

1. Introduction

One of the promising areas of automotive technology, which focused considerable efforts of researchers, is the developing both fully and semi-autonomous car technology. This technology will help improve traffic flow, reduce congestion, reduce the potential for accidents, assist and enhance the drivers, and suit their mood of needs.

For off-road driving the driver usually should retain control of the car. And when the driver is doing the driving, these intelligent systems will be working in the background to keep him safe. Surface identification is a prototype sensing technology that is a key part of the journey towards fully autonomous driving on any terrain. This technology uses microwave and ultrasonic sensors to scan the terrain ahead of the car; it provides the vehicle terrain response system with the optimum settings for the surface ahead. The use of remote sensing will allow the terrain response system to adjust appropriate terrain response settings automatically and pre-emptively.

In [1] preliminary results have been presented in recognizing a set of surfaces by means of a developed system. It has been demonstrated that backscattered signals carry information on the properties of the surface and the artificial neural network (ANN) classifier based on multilayer perceptron (MLP) structure [2] provides the best performance, comparing with other widely used supervised classification methods.

In the presence of a large number of surface types and a large number of signal features, such network becomes complex and poorly generalized. In a conventional ANN the emphasis is put on those training data where performance is poor in order to retrain the weak learning algorithm, resulting in decreased classification accuracy on the average. Therefore in the present study we paid particular attention to modular neural networks, which allow an overall increase in classification accuracy in such complicated cases.

2. Modular Neural Networks

Recently there has been a growing interest in combining ANNs in order to either improve or extend their performance [3, 4]. The combining of networks can lead to improved performance in terms of better generalization, and in terms of increased efficiency, and clearer design. The advantage of the modular system is not only the accuracy but also the parallelism as every network can be trained on a separate computer which provides less training time. The modularity powers the system with scalability because if new specific class is added we don't have to train all the networks but only the branch (the neural networks) affected by the new class.

This research aims to examine the difference between a modular ANN and a conventional ANN used for surface classification. Better performance as a result of taking a modular approach is reported by several researches [3, 5]. To accomplish this surface classification process a conventional single stage ANN and two different modular neural network systems were utilized. ANNs were based on MLP structure, which is a feed forward ANN model that maps sets of input data (x_1, x_2, \dots, x_m) onto a set of appropriate outputs $(\hat{y}_1, \hat{y}_2, \dots, \hat{y}_n)$ (Fig. 1a). MLP consists of input, output layers and one hidden layer with a different number of nodes in a directed graph [2].

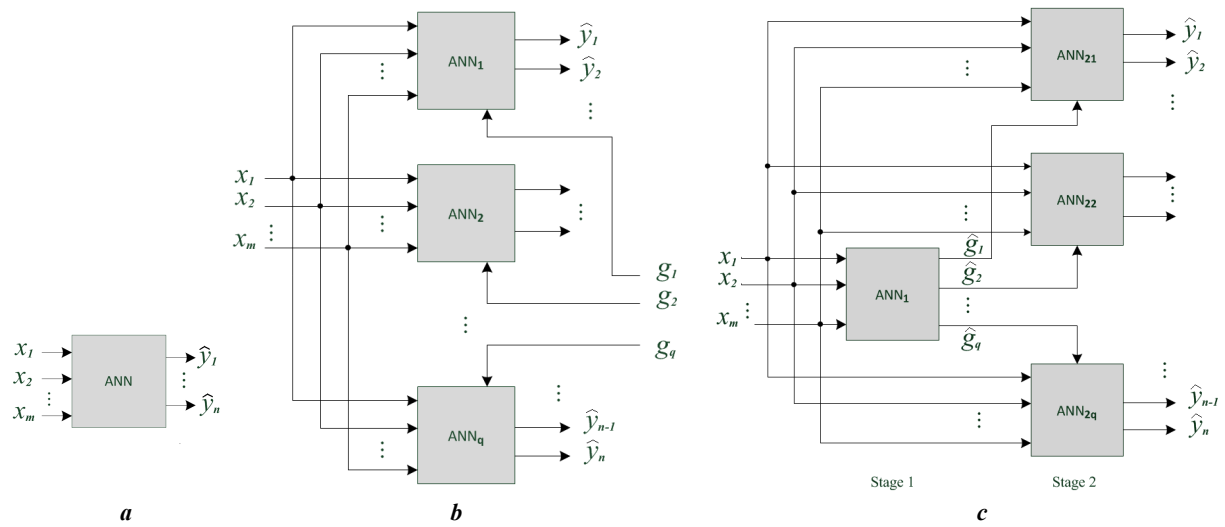

Figure 1. Artificial neural networks with conventional (a), cooperative (b), and supervisory (c) structures

The object of classification is to design a rule that assigns objects (experimental results) to one of the classes (surfaces), on the basis of feature vectors of those objects. The simplest performance metrics can rely on computing the classifier's predicted classes $\hat{y}_1, \hat{y}_2, \dots, \hat{y}_n$ for the p test patterns with their true labels y_1, y_2, \dots, y_n . The primarily statistics of interest are misclassification counts. True Positives (TP) together with False Positives (FP) form a confusion matrix (Table I). In machine learning and statistics, the most widely used summary of the above matrix is the error rate (Er), which is simply the total misclassification count divided by the number of examples (test patterns). In this paper we will also use true positive rate (or accuracy), which is the percent of correct classifications $Tr = 1 - Er$ and can be derived from the confusion matrix:

$$Tr = \frac{1}{p} \sum_{i=1}^n TP_i. \quad (1)$$

TABLE I. CONFUSION MATRIX

		Predicted			
		\hat{y}_1	\hat{y}_2	\dots	\hat{y}_n
Actual	y_1	TP_1	FP_{12}	\dots	FP_{1n}
	y_2	FP_{21}	TP_2	\dots	FP_{2n}
	\dots	\dots	\dots	\dots	\dots
	y_n	FP_{n1}	FP_{n2}	\dots	TP_n

Results obtained with such conventional ANN, we will compare with the results achievable when using modular neural networks. Relationship between ANN modules can be characterized as successive, cooperative, or supervisory [6]. A successive relationship between modules involves the decomposition of a global task into successive tasks where each is carried out by a specialized module. In a cooperative relationship between modules some mechanism could be used to select which specialist module was more appropriate for particular input data, with the result that the input data would only be presented to that module. It is possible for artificial neural network modules to be in supervisory relationship with each other when one artificial neural network module is trained to select the parameters of a second net.

In Fig. 1b the block diagram of cooperative ANN is shown. In the first phase of cooperative modular network development, all surfaces are divided into q classes by some criterion. External triggers (g_1, g_2, \dots, g_q) are used to select the ANN module.

The true positive rate of a cooperative ANN can be calculated as the ratio of correctly classified surfaces to the total number of test patterns:

$$Tr_C = \frac{1}{p} \sum_{i=1}^q \sum_{j=1}^{n_i} TP_{ij}. \quad (2)$$

where TP_{ij} is the True Positives on the j^{th} output of i^{th} ANN _{i} , n_i is the number of ANN _{i} outputs (number of surfaces in the i^{th} class). Similar to (1),

$$Tr_i = \frac{1}{p_i} \sum_{j=1}^{n_i} TP_{ij}. \quad (3)$$

where p_i is the number of test patterns of i^{th} ANN. Therefore (2) can be represented as a weighted sum of the true positive rates of the individual networks:

$$Tr_C = \sum_{i=1}^q \frac{p_i}{p} Tr_i. \quad (4)$$

The second modular ANN, applied for surface classification, was based on a two-stage supervisory structure (Fig. 1c). All surfaces are divided into q classes by the criterion of their features proximity. The first stage ANN₁ should be trained to make a division between the classes. Its outputs (g_1, g_2, \dots, g_q) trigger the appropriate second-stage ANN, which should classify the surface within the corresponding class. The true positive rate of two-stage ANN can be calculated as the ratio of correctly classified surfaces to the total number of test patterns:

$$Tr_S = \frac{1}{p} \sum_{i=1}^q \sum_{j=1}^{n_i} TP_{ij}. \quad (5)$$

In (5) TP_{ij} is the True Positives on the j^{th} output of the second stage ANN_{2i}, n_i is the number of ANN_{2i} outputs (number of surfaces in i^{th} class). Similar to (1), the true positive rate of the first stage ANN₁ can be written as:

$$Tr_1 = \frac{1}{p} \sum_{i=1}^q TP_i. \quad (6)$$

Taking into consideration that True Positives on i^{th} output of the first stage ANN₁ equal to the number of patterns of the second stage ANN_{2i} (indeed, the signal is supplied to ANN_{2i} only if ANN₁ decides that the surface belongs to i^{th} class), we can write:

$$TP_i = p_i = \sum_{j=1}^{n_i} TP_{ij} + \sum_{j=1}^{n_i} \sum_{\substack{k=1, \\ k \neq j}}^{n_i} FP_{ijk}. \quad (7)$$

Therefore the equation (5) can be expressed as

$$Tr_s = Tr_1 - Er_2. \quad (8)$$

Thus, the true positive rate of two-stage ANN equals to the difference between the true positive rate of the first stage and the error rate of the second stage. From (1) and (8) follows that in order to improve accuracy compared with the conventional network, multi-stage network should provide a significant increase in the accuracy of the identification of classes of surfaces, i.e. $Tr_1 > Tr$. Optimal partition of surfaces into classes is the key to the effectiveness of multi-stage network.

Modular ANN structures are not limited to the examples discussed in this paper. For example, the combination of structures shown in Fig. 1a and Fig. 1c looks promising. In such ANN classification of some surfaces is performed in the first stage, and the others - in the second stage. In a presence of a large number of classes, multistage networks, consisting of three or more levels, may be used.

3. The Experiment

In this paper we will consider a method of road surface classification based on the system described in [1]. In our study, we combine 24 GHz polarimetric radar and 40 kHz sonar mounted on a vehicle. A number of studies, a review of which is given in [1], have shown that polarimetric radar is an effective method of surface classification, because radar signal depolarisation is determined by the dielectric constant of the surface material and the surface roughness. Moreover, the amplitude and the envelope of the backscattered signal depend on the surface parameters, such as surface dielectric constant, roughness, wetness, density, surface cover, etc. The differences in the reflected signals, clearly visible in Fig. 2, allow implementation of surface identification system, based on statistical classification methods.

The analysis of the performance of classifiers was based on the database, which consisted of more than 1400 recorded combinations of radar and ultrasonic backscattered signals. The database was collected at about 40 outdoor locations to ascertain repeatability of backscattering properties from surfaces related to categories under investigation.

Fourteen various types of surfaces have been included into the database: dry asphalt, asphalt, covered with snow, dry bitumen, dry gravel, dry grass, wet grass, dry ground, wet ground, dry sand, dry snow, wet snow, snow covered with crust, clear ice, and ice covered with snow.

The full list of available features consists of 34 different parameters: average sonar and polarimetric radar signal power reflected from three surface swathes in the range from 1.5 m to 4.0 m; power and duration above the threshold and standard deviation of the backscattered signal [1].

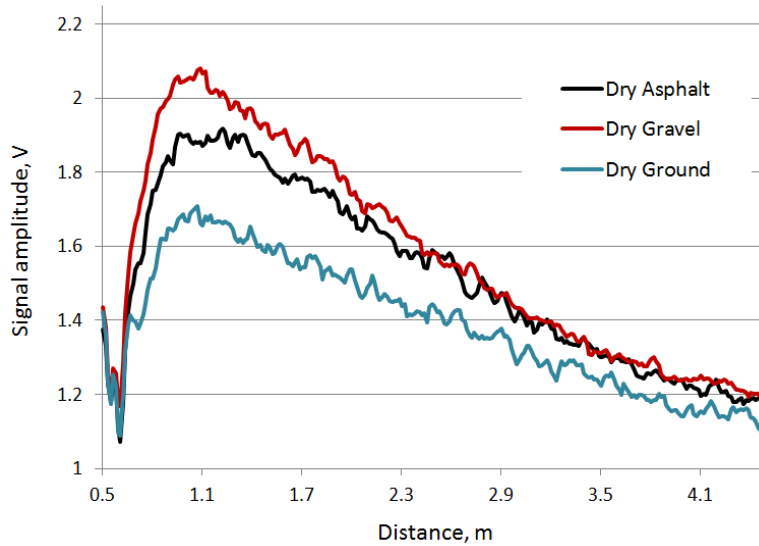

Figure 2. Typical backscattered signals

Our approach to the optimal choice of features was based on sequential forward selection method: we added features one by one, at each step adding the one that decreases the error the most, until any further addition did not decrease the error. The average classification accuracy dependence on the number of features, achieved using a conventional ANN, is shown in Fig. 3. Five most significant features provide classification accuracy of about 75%; increasing the number of features from 5 to 10 increases accuracy by 15%; increasing the number of features over 13 does not improve the classification accuracy.

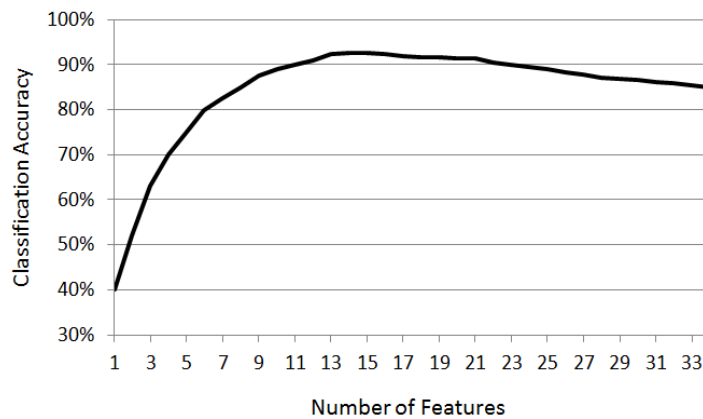

Figure 3. Dependence of the classification accuracy on the number of signal features

As a starting point, we took results obtained using single ANN which was based on a conventional structure. To obtain the optimum ANN parameters, Bayesian regularization training algorithm was used. After the ANN had been trained its performance towards a set of test data was assessed. The results of classification are presented in Fig. 4. As can be seen from Fig. 4, this method shows sufficient performance with the average classification accuracy of 92.4%.

However, the accuracy of recognition of certain surfaces was significantly lower than the average accuracy. Thus, dry ground in 15% of cases was not recognized correctly. The same problem arises in recognition of ice, wet snow, snow on ice, and snow on asphalt.

In order to improve the general classification accuracy we have applied two types of modular ANNs, described in the previous section. The first analysed neural network was based on a

cooperative structure. We have divided all surfaces into two classes ($q=2$), depending on the ambient temperature:

- Class 1: all kinds of ice and snow, snow on asphalt (six surfaces);
- Class 2: asphalt, bitumen, gravel, dry and wet grass, dry and wet ground, sand (eight surfaces).

This approach is not suitable for the case of near-zero temperature; however, such division criteria can be applied in many practical cases.

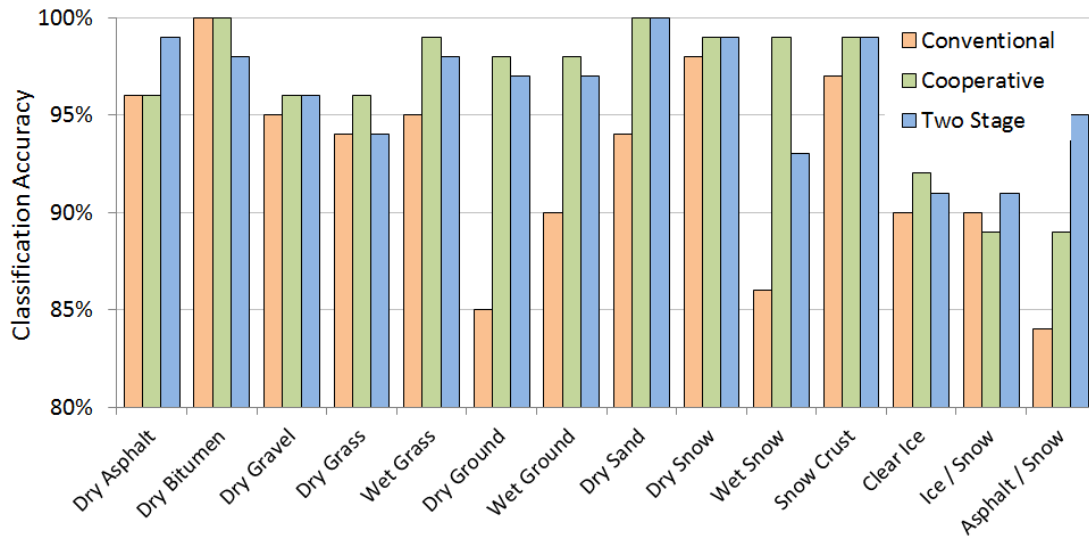

Figure 4. Accuracy of classification of different surface types

The developed modular network contains two ANNs; each of them has 13 input nodes (number of features), one hidden layer with 12 hidden nodes, and output layer with six nodes in the first ANN and eight nodes in the second ANN. Each ANN was trained and tested with a separate set of training and test patterns which is consistent with a set of surfaces provided for this network. The average accuracy of the first ANN was 94.5%, the average accuracy of the second ANN was 97.9%, and according to (4) the average accuracy of cooperative ANN was 96.4%. As can be seen from Fig. 4, there was a significant increase in the accuracy of classification of Class 2 surfaces: wet grass, dry ground, wet ground, and dry sand, as well as recognition of wet snow from Class 1. At the same time this network could not significantly improve the differentiation between clear ice, snow on ice, and snow on asphalt.

Therefore, use of a priori knowledge about driving conditions seems to be a very effective way to simplify the ANN and increase its accuracy.

The second analysed network was based on a two-stage supervisory structure. In order to define classes of surfaces (e.g. find surfaces with similar features) we conducted a stepwise classification, at every step removing from the training database the surface, which was closest to the surface of interest to us. As a result all surfaces were grouped into the following three classes of surfaces with similar features:

- Class 1: clear ice, ice covered with snow, snow on asphalt (three surfaces);
- Class 2: dry ground, wet ground, sand (three surfaces);
- Class 3: eight remaining surfaces.

The considered modular network contains one first stage ANN and three second stage ANNs. All ANNs possess 13 input nodes, one hidden layer with 12 hidden nodes and output layer with the number of output nodes, which corresponds to the number of surfaces within this ANN. These networks have been trained and tested with the same sets of training and test patterns, respectively.

The first stage ANN provided good separation between three classes of surfaces with the average accuracy of 97.7% ($TP_1/p=0.974$, $TP_2/p =0.930$, and $TP_3/p =0.996$). The average accuracy, achieved with the use of two-stage ANN, was 96.2% (8) and increased by almost 4% comparing with a conventional ANN; however it is slightly less than the accuracy of cooperative ANN. Nevertheless, as can be seen from Fig. 4, the classification accuracy of some surfaces has increased considerably. For example, dry asphalt in 99% of cases was recognised correctly and snow and ice on asphalt – in 95%.

From Fig. 5 we can see that multi-stage ANNs provide higher average classification accuracy and less dispersion of classification accuracy of the individual surfaces in comparison with a conventional network.

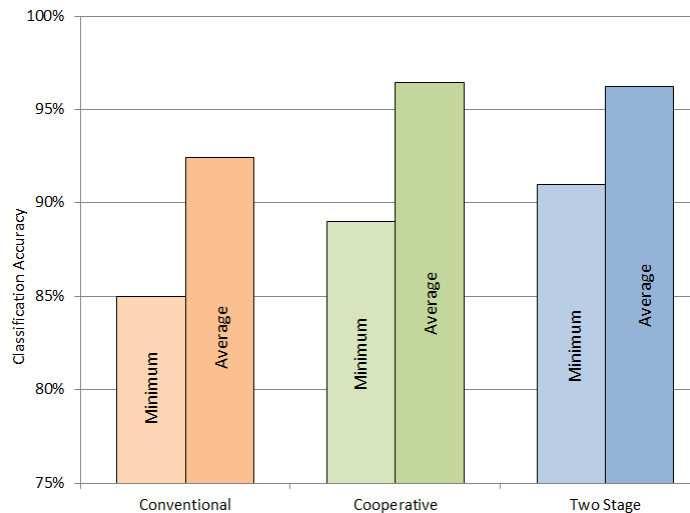

Figure 5. Classification accuracy of ANNs with different structures

4. Conclusions

In the present study we investigated the efficiency of modular neural networks for road surface classification by analysing backscattered radar and sonar signals. Our results show that the use of modular networks can significantly increase the accuracy of surface classification. The neural network with the cooperative structure showed better average results, while two-stage neural network with the supervisory structure showed better results in differentiating between surfaces with similar features. The proposed technique was tested for recognition of a large number of real surfaces in different weather conditions with the average accuracy of correct classification above 95%.

Acknowledgment

This work has been supported by Jaguar Land Rover.

References

- [1] A. Bystrov, M. Abbas, E. Hoare, T.-Y. Tran, N. Clarke, M. Gashinova and M. Cherniakov, “Analysis of Classification Algorithms Applied to Road Surface Recognition”, *Proc. IEEE Radar Conference (RadarCon)*, Arlington, USA, 2015, pp. 0907–0911.
- [2] S. Haykin, *Neural Networks: A Comprehensive Foundation*, Macmillan College, London, 1999.
- [3] A.J.C. Sharkey, “Multi-net systems”, *Combining Artificial Neural Nets: Ensemble and Modular Multi-net Systems*, Berlin, Springer, 1998, pp.1–30.

- [4] S. Yang and A. Browne, "Neural network ensembles: combining multiple models for enhanced performance using a multistage approach", *Expert Systems*, 2004, Vol.21, No.5, pp. 279–288.
- [5] A. Howard, C. Patter, and C.C. Liebe, "A multi-stage neural network for automatic target detection", *Proc. IEEE World Congress on Computational Intelligence*, 1998, Vol.1, pp.231-236.
- [6] V. Tyagi and A. Mishra, "A survey on ensemble combination schemes of neural network", *Int. Journal of Computer Application*, 2014, Vol.95, No.16, pp.18–21.