

UNIVERSITY OF BIRMINGHAM

Research at Birmingham

Liquid air utilization in air conditioning and power generating in a commercial building

Ahmad, Abdalqader; Al-Dadah, Raya; Mahmoud, Saad

DOI:

[10.1016/j.jclepro.2017.02.143](https://doi.org/10.1016/j.jclepro.2017.02.143)

License:

Creative Commons: Attribution-NonCommercial-NoDerivs (CC BY-NC-ND)

Document Version

Peer reviewed version

Citation for published version (Harvard):

Ahmad, A, Al-dadah, R & Mahmoud, S 2017, 'Liquid air utilization in air conditioning and power generating in a commercial building', *Journal of Cleaner Production*, vol. 149, pp. 773-783.
<https://doi.org/10.1016/j.jclepro.2017.02.143>

[Link to publication on Research at Birmingham portal](#)

General rights

Unless a licence is specified above, all rights (including copyright and moral rights) in this document are retained by the authors and/or the copyright holders. The express permission of the copyright holder must be obtained for any use of this material other than for purposes permitted by law.

- Users may freely distribute the URL that is used to identify this publication.
- Users may download and/or print one copy of the publication from the University of Birmingham research portal for the purpose of private study or non-commercial research.
- User may use extracts from the document in line with the concept of 'fair dealing' under the Copyright, Designs and Patents Act 1988 (?)
- Users may not further distribute the material nor use it for the purposes of commercial gain.

Where a licence is displayed above, please note the terms and conditions of the licence govern your use of this document.

When citing, please reference the published version.

Take down policy

While the University of Birmingham exercises care and attention in making items available there are rare occasions when an item has been uploaded in error or has been deemed to be commercially or otherwise sensitive.

If you believe that this is the case for this document, please contact UBIRA@lists.bham.ac.uk providing details and we will remove access to the work immediately and investigate.

Accepted Manuscript

Liquid Air utilization in air conditioning and power generating in a commercial building

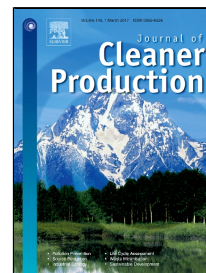

Abdalqader Ahmad, Raya Al-Dadah, Saad Mahmoud

PII: S0959-6526(17)30369-4
DOI: 10.1016/j.jclepro.2017.02.143
Reference: JCLP 9069
To appear in: *Journal of Cleaner Production*
Received Date: 14 July 2016
Revised Date: 19 February 2017
Accepted Date: 20 February 2017

Please cite this article as: Abdalqader Ahmad, Raya Al-Dadah, Saad Mahmoud, Liquid Air utilization in air conditioning and power generating in a commercial building, *Journal of Cleaner Production* (2017), doi: 10.1016/j.jclepro.2017.02.143

This is a PDF file of an unedited manuscript that has been accepted for publication. As a service to our customers we are providing this early version of the manuscript. The manuscript will undergo copyediting, typesetting, and review of the resulting proof before it is published in its final form. Please note that during the production process errors may be discovered which could affect the content, and all legal disclaimers that apply to the journal pertain.

Liquid Air utilization in air conditioning and power generating in a commercial building

Abdalqader Ahmad^a, Raya Al-Dadah^a, Saad Mahmoud^a

The University of Birmingham, School of Mechanical Engineering,
Edgbaston, Birmingham, B15-2TT, UK

* Email: alnoosory@yahoo.com

Tel. No: 00447753359551

Abstract

Current air conditioning (AC) systems use a vapour compression system that consume a great amount of energy particularly during the peak times where most electricity suppliers facing difficulties to meet the users demands. Shifting the peak cooling demands to off-peak times using cold energy storage systems is a promising technique leads to save energy and to reduce the CO₂ emissions. This study presents new technology that uses the cold energy storage in form of liquid Air (LAir) or liquid nitrogen (LN2) to provide air conditioning and power to commercial buildings. Four different cryogenic cycles were modelled and analysis from a thermodynamic point view, and compared in terms of their, output power, cooling capacity, recovery efficiency, COP and how much energy could save when compared with the traditional AC system. The results showed that system performance when LAir is used is 21-25% higher than that of when LN2 is used, and the 4th configuration is the most effective cycle and it recovered up to 94% of the energy stored in LAir and 78% of the energy stored LN2. Compared to the conventional system at the current LAir and LN2 prices, the 1st, 2nd, 3rd and 4th cycles showed saving up to 15%, 24%, 31% and 37.5%, respectively, when LAir is used and -3.5%, 5%, 16% and 24%, consecutively, when LN2 is used.

Key words; liquid air/nitrogen; cryogenic system; air conditioning; peak demand; cold storage

1- Introduction

Conventional air conditioning (AC) systems use a vapour compression system that consumes a great amount of energy particularly during the peak times, and the demands of these systems have increased rapidly over the last few decades. Forecasts have shown that space cooling demands in Europe will increase rapidly over the next 15 years by 72% and will reach 30 times its current value by 2100 (Ahmad et al., 2016; Cox, 2012; Davis and Gertler 2015). Shifting the peak cooling demands to off-peak times using cold energy storage systems is a promising technique leads to save energy, to reduce the CO₂ emissions and to reduce the system size (Navidbakhsh et al., 2013). However, the performance of this technique affects significantly by the chosen storage medium, storage temperature and the operating strategy (Zhai et al., 2013).

There is a new cooling systems use cold storage medium in form of liquefied gases such as liquefied natural gas, air, nitrogen and CO₂ was also reported, and liquid air / nitrogen were considered as the most attractive storage

33 medium due their high energy density, availability and environmental friendly (Knowlen et al., 1998). Place, 1909
34 developed LAir cooling system to cool railway carriages to preserve food by evaporating it in channels fitted around
35 the cooling space. An air conditioning uses liquid air was developed by Harold in 1960 where the liquid air is
36 evaporated in a heat exchanger then vented to the cooling space. A liquefied nitrogen and natural gas uses to cool a
37 food transport lorry where the liquefied gases evaporated and superheated in heat exchanger fitted in the cooling
38 space roof to generate cooling and then the mixture uses to run the lorry engine (Newman et al., 2014). Saia et al.,
39 1994 modified the conventional refrigerator of a food transport lorry which uses to transfer a frozen food, using a
40 liquefied carbon dioxide. The system evaporates liquid CO₂ in a heat exchanger fitted around the cooling space and
41 provides cool at a wide range of sub-zero temperatures. Cooling the cutting tools using LN₂ with a compressed air
42 and lubricating fluids was also reported and tested by many researchers. This technique leads to reduce the tip
43 temperature, cutting force, the consumption of the cutting fluid and increase the cutting speed and the feed rate
44 (Tazehkandi et al., 2015; Giasin et al., 2016; Pereira et al., 2016). An air conditioning system and refrigerator that
45 use a direct spray of LAir into the cooling space were reported by (Garlov et al., 2002). Skobel et al. 2012 developed
46 a beverage dispenser that uses liquid nitrogen (LN₂) cooling system and it was effective in producing cooling, quite,
47 suitable for remote areas and environmental friendly. A LAir engine that provides cooling and power for food
48 transport vehicles was presented by (Strahan et al., 2013; Dearman, 2015) and the engine is used to run a traditional
49 AC system and other auxiliary devices. Exhaust cool from the engine is used to enhance the performance of the AC
50 system by reducing its condenser temperature. A comprehensive study of various cryogenic cycles that use LN₂ to
51 provide cooling and power for domestic applications was carried out by Ahmad et al. 2016, and the results showed
52 that, at the current LN₂ prices savings up 36% was achieved and 74% of the LN₂ stored energy was recovered
53 (Ahmad et al. 2016)

54 The above mentioned work shows using cold storage systems in form of liquid Air/nitrogen to provide cooling
55 and power is feasible and leads to save energy, reduce the CO₂ emissions and reduce the peak electricity demands.
56 The last mentioned work was used LN₂ to provide cooling and power for domestic applications, however, mere than
57 25% of the energy consumed to produce LN₂ does not recovered. The current study aims to investigate using LAir,
58 which consumes 20% less energy than LN₂, to provide cooling and power to a commercial building located in
59 Ahwaz, Iran (Navidbakhsh, et al., 2013). A thermodynamic analysis of four different cryogenic cooling and power
60 cycles were carried out modeled using MATLAB integrated with REFPROP software. These cycles were compared
61 in terms of their cooling capacities and output powers, recovery efficiencies and COPs, and also were compared
62 with the conventional AC system (MATLAB, 2008; REFPROP, 2010).

63

64 2- Proposed cryogenic cooling and power cycles

65 The proposed systems use the cold stored energy in form of liquid air to generate air conditioning and power for
66 commercial buildings at the peak times to save energy, to increase the national electricity grid stabilities by reducing
67 the peak electricity demands. The proposed systems consist of two circuits; the first one circulates a secondary
68 coolant to meet the building cooling demands. This cooling load is used as heat source to the second circuit (LAir
69 cycle) which provides cooling and power by evaporating pressurized LAir and expanded it in an expander. Four
70 different cryogenic cycles were modelled using MATLAB combined with REFPROP software to find out the most
71 efficient cycle that recovers most of the energy stored in LAir. The model investigates wide range of LAir inlet
72 pressure (represented by P_{2A} in the following figures) to find out how it will affect the system performance, and a
73 cost analysis to compare the conventional AC system with the proposed systems was also carried out.

74 The first cycle is shown in Fig. 1(a, b) where the liquefied air is pumped to a coil immersed inside the cooling tank
75 to be evaporated and superheated by the secondary coolant load before it passes through an expander to generate
76 power. The expansion process can be either adiabatic or isothermal expansions as shown in Fig. 3b. In the adiabatic
77 expansion scenario, the expansion process reduces the air outlet temperature so it returns to the cooling tank in order
78 to increase the system cooling capacity. However, for the isothermal expansion scenario (that represented by dash
79 line in Fig. 1b) where the expanded air leaves at the secondary coolant temperature, so it vents directly to the
80 atmosphere. This later scenario has advantages by absorbing more heat in the expansion process which increases the
81 system cooling capacity and output power. Also the inlet pressure (P_{2A}) can be increased to more than 500 bar
82 whereas this value cannot exceeds 100 bar in the first scenario duo to lowering the exit temperature below saturated
83 line as shown in the expansion process (a-b) in Fig.1b. More than 80% of the isothermal expansion can be
84 practically achieved by gaining heat from the surroundings using secondary fluid or by having a high value of
85 surface to volume ratio expander or by three stage expander with reheat after the first and the second stage (Ahmad
86 et al., 2016; North, 2008; Knowlen, et al., 1997; Vitt and Peter, 1997; Ordonez, 2000).

87 The second cycle is presented in Fig. 2(a, b) where the previous LAir cooling and power cycle is used to drive a
88 closed Brayton cycle by cooling down its working fluid (in the process 4B-1B) while the LAir evaporates and
89 superheats in the process (2A-3A). The cooling process followed by compression (1B-2B), heating (2B-3B) and
90 expansion (3B-4B) processes as shown in the Fig.2. The closed Brayton cycle output power affects by its mass flow
91 rate, which depends on the selected evaporator outlet temperature (T_{3A}), and its pressure ratio, which restricts by the
92 compressor outlet temperature (T_{2B}) which has to be less than the secondary coolant temperature. These values and
93 the closed cycle working fluid should be carefully selected to achieve the maximum output power and to avoid any

94 condensation in the evaporator. The closed Brayton working fluid should has boiling point lower than that of LAir
 95 and many gases can be used such as Neon, Helium or Hydrogen, and the later one was selected for the current work.

96 The third cycle is similar to the second cycle; however, in this case LAir power cycle drives a closed Rankine cycle
 97 which more efficient the Brayton cycle. The cycle is shown in Fig.3(a, b) where closed Rankine cycle (1R, 2R, 3R
 98 and 4R) uses LAir to condense it working fluid in HE1 while it evaporates and superheats. The condensed fluid is
 99 pumped to a separate heat exchanger immersed in the cooling tank (1R-2R) to evaporate and superheat in the
 100 process (2R-3R) then expanded in a separate expander (3R-4R). The closed cycle working fluid should be carefully
 101 selected to achieve the maximum output power. Xenon with boiling temperature of $-108\text{ }^{\circ}\text{C}$ at atmospheric pressure
 102 was selected as working fluid of the closed Rankine cycle in this study.

103 Fig.4(a, b) shows the fourth cycle where the LAir cycle drives two cascades closed Rankine cycles which are named
 104 as the first and the second closed Rankine cycles. The first closed Rankine cycle represents by (1R, 2R, 3R, 4R and
 105 5R) and the second closed Rankine cycle represents by (1R', 2R', 3R' and 4R'). The LAir evaporates and
 106 superheats (2A-3A) in HE1 while it condenses the first closed Rankine cycle working fluid (5R-1R). Then the
 107 superheated air passes through HE2 and the cooling tank (3A-4A and 4A-5A) for further heating before it expands
 108 in an expander (5A-6A). The condensed fluid of the first closed cycle is pumped to HE2 (1R-2R) where it
 109 evaporates (2R-3R) and condenses the second closed cycle working fluid (4R'-1R'). Then the vapour passes through
 110 a separate expander (4R-5R) after been superheated in the cooling tank (3R-4R). The second closed cycle working
 111 fluid pumps to the cooling tank (1R'-2R') where it evaporates and superheats (2R'-3R') then passes through another
 112 separate expander. The working fluids of the two closed Rankine cycles should be carefully selected to meet the
 113 cycle and the application requirements. For the current study R14, which boils at $-127\text{ }^{\circ}\text{C}$ at the atmospheric
 114 pressure, was chosen as working fluid for the first closed cycle and R13, which boils at $-81\text{ }^{\circ}\text{C}$ at the atmospheric
 115 pressure, was chosen as working fluid for the second closed cycle.

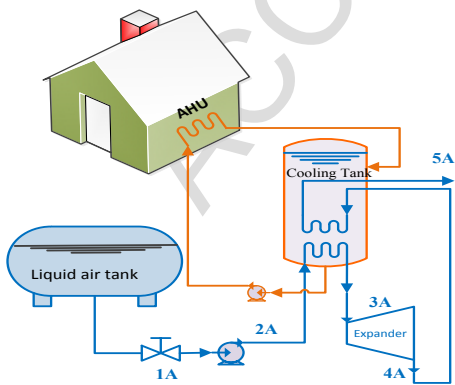

Fig. 1a First cycle, LAir cooling and power cycle

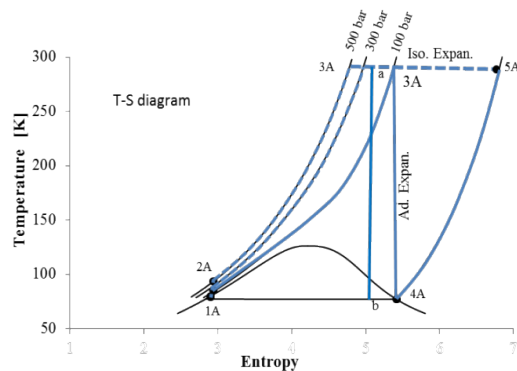

Fig. 1b First cycle's T-S diagram.

117

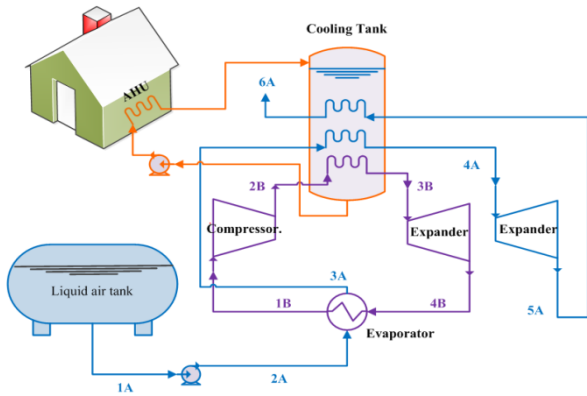

Fig.2a Second cycle, LAir drives closed Brayton cycle

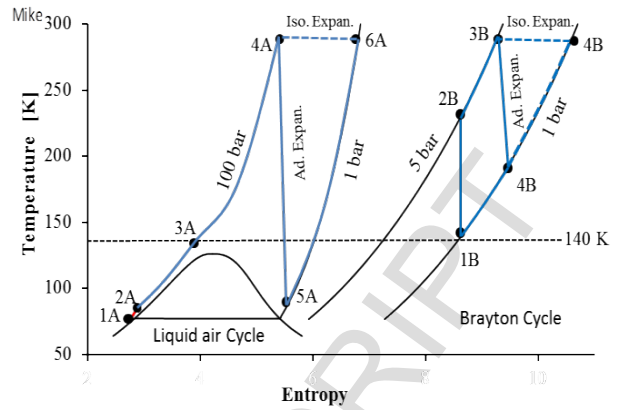

Fig.2b Second cycle's T-S diagram.

118

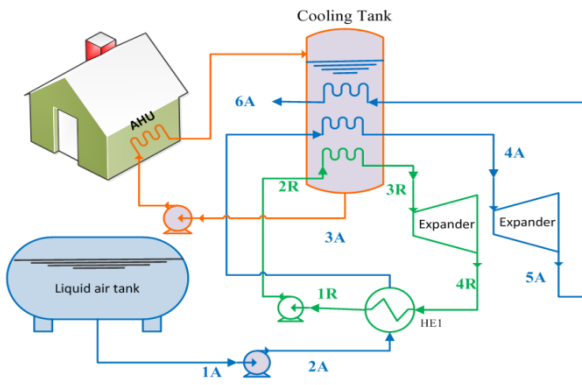

Fig.3a Third cycle, LAir drives closed Rankine cycle

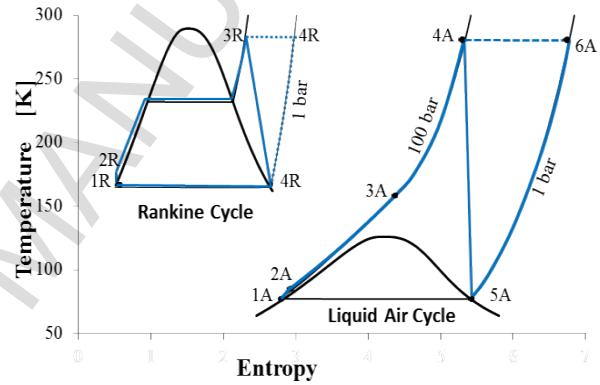

Fig.3b Third cycle's T-S diagram

119

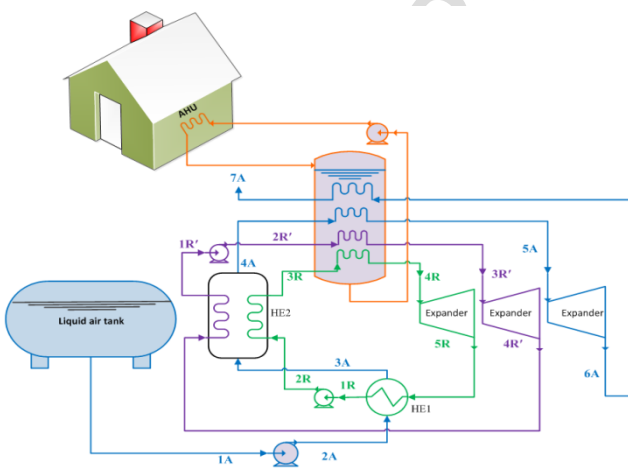

Fig.4a Fourth cycle, LAir drives two closed Rankine cycles

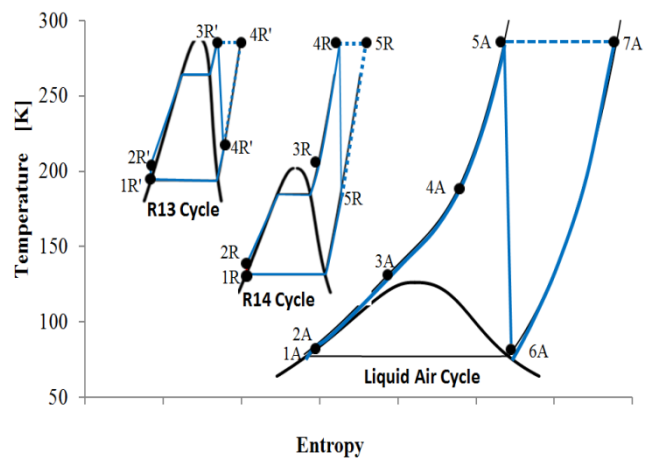

Fig.4b Fourth cycle's T-S diagram.

120

121 **3- Thermodynamic modelling**

122 The proposed cycles were analysed from thermodynamic point view to find out the most effective system
 123 which recovers most the energy storage in LAie/LN2, and provide higher output power and cooling capacity to
 124 for the selected application. A mathematical model was developed for each of the above cycles using MATLAB
 125 combined with REFPROP software to (a) calculate the properties of all working fluids at each state in the cycle,
 126 (b) optimizer the operating conditions, (c) solve the energy and mass balance equations, (d) calculate LAir/LN2
 127 mass flow rate, power output, cooling capacity, efficiency and the cycle COP. Both expansion processes were
 128 considered in the current study and a wide range of the inlet pressure (P_{2A}) was discovered. The model was
 129 simplified by the following:

- 130 • Liquid enters to the system at 78 K at near atmospheric pressure, and leaves as gas at 283 K.
- 131 • Heat absorbs or loss from/into the surroundings is negligible.
- 132 • The inlet pressure of all pumps and compressors is atmospheric pressure.
- 133 • The isentropic efficiency of pumps, expanders and compressors are 90%, 90% and 85% respectively.
- 134 • The pressure drop in all cycle's components is negligible.

135 For the first cycle shown in Fig.1 (a, b), the specific work output was calculated using Eqs.1 when adiabatic
 136 expansion process is considered and Eq.2 when isothermal expansion process is considered.

$$137 \quad W_{Ad} = [(h_{3A} - h_{4A}) - (h_{2A} - h_{1A})] \quad (1)$$

$$138 \quad W_{Iso} = [T_{tank}(s_{4A} - s_{3A}) - (h_{2A} - h_{1A})] \quad (2)$$

139 Where; W is specific work in kJ/kg, h is the specific enthalpy in kJ/kg T is temperature in K and s is specific
 140 entropy in kJ/kg-K. Whereas the subscripts Ad , Iso , A and $tank$ refer to adiabatic expansion, isothermal
 141 expansion, LAir cycle and cooling tank, respectively. While the specific cooling capacity was calculated using
 142 Eqs.3 for the adiabatic expansion and Eqs.4 for the isothermal expansion process.

$$143 \quad CC_{Ad} = [(h_{3A} - h_{4A}) + (h_{5A} - h_{4A})] \quad (3)$$

$$144 \quad CC_{Iso} = [T_{tank}(s_{4A} - s_{3A})] \quad (4)$$

145 Where; CC is specific cooling capacity in kJ/kg.

146 Regarding the second cycle shown in Fig.2 the ratio of the closed Brayton cycle mass flow rate to the LAir
 147 mass flow rate was calculated first by applying energy balance equation to the fluids enter and leave the
 148 evaporator using Eq.5.

$$149 \quad m_r = \frac{\dot{m}_B}{\dot{m}_A} = \frac{(h_{3A} - h_{2A})}{(h_{1B} - h_{4B})} \quad (5)$$

150 Where; \dot{m}_B is the mass flow rate in kg/s for the closed Brayton cycle, and \dot{m}_A is the mass flow rate of the LAir
 151 cycle in kg/s. The specific output works were calculated using Eqs. 6-8 for the adiabatic expansion and Eqs. 9-
 152 11 for the isothermal expansion processes.

$$153 \quad (W_A)_{Ad} = [(h_{4A} - h_{5A}) - (h_{2A} - h_{1A})] \quad (6)$$

$$154 \quad (W_B)_{Ad} = m_r [(h_{3B} - h_{4B}) - (h_{2B} - h_{1B})] \quad (7)$$

$$155 \quad W_{Ad} = (W_A)_{Ad} + (W_B)_{Ad} \quad (8)$$

$$156 \quad (W_A)_{Iso} = [T_{tank}(s_{5A} - s_{4A}) - (h_{2A} - h_{1A})] \quad (9)$$

$$157 \quad (W_B)_{Iso} = m_r [T_{tank}(s_{4B} - s_{3B}) - (h_{2B} - h_{1B})] \quad (10)$$

$$158 \quad W_{Iso} = (W_A)_{Iso} + (W_B)_{Iso} \quad (11)$$

159 Where; the subscript *A* refers to the LAir cycle, and the subscript *B* refers to the closed Brayton cycle. The
 160 specific cooling capacity was calculated using Eq.12 when adiabatic expansion process is considered and Eq.13
 161 when the isothermal expansion process is considered.

$$162 \quad CC_{Ad} = [(h_{4A} - h_{3A}) + (h_{6A} - h_{5A})] + m_r (h_{3B} - h_{2B}) \quad (12)$$

$$163 \quad CC_{Iso} = [T_{tank}(s_{5A} - s_{4A})] + m_r [T_{tank}(s_{4B} - s_{3B})] \quad (13)$$

164 In the same previous manner, the ratio of the closed Rankine cycle mass flow rate to the LAir mass flow rate
 165 for the third cycle shown in Fig.3 was calculated first by applying energy balance equation to the fluids enter
 166 and leave HE1 as in the following Eq14.

$$167 \quad m_r = \frac{\dot{m}_R}{\dot{m}_A} = \frac{(h_{3A} - h_{2A})}{(h_{1R} - h_{4R})} \quad (14)$$

168 Where; \dot{m}_R is the mass flow rate of the closed Rankine in kg/s and subscript *R* referred to the closed Rankine
 169 cycle, the specific output works were calculated using Eqs. 15-17 for the adiabatic expansion and Eqs. 18-20 for
 170 the isothermal expansion processes.

$$171 \quad (W_A)_{Ad} = [(h_{4A} - h_{5A}) - (h_{2A} - h_{1A})] \quad (15)$$

$$172 \quad (W_R)_{Ad} = m_r [(h_{3R} - h_{4R}) - (h_{2R} - h_{1R})] \quad (16)$$

$$173 \quad W_{Ad} = (W_A)_{Ad} + (W_R)_{Ad} \quad (17)$$

$$174 \quad (W_A)_{Iso} = [T_{tank}(s_{5A} - s_{4A}) - (h_{2A} - h_{1A})] \quad (18)$$

$$175 \quad (W_R)_{Iso} = m_r [T_{tank}(s_{4R} - s_{3R}) - (h_{2R} - h_{1R})] \quad (19)$$

$$176 \quad W_{Iso} = (W_A)_{Iso} + (W_R)_{Iso} \quad (20)$$

177 The specific cooling capacity was calculated using Eq.21 when the adiabatic expansion process is considered
 178 and Eq.22 when the isothermal expansion process is considered.

$$179 \quad CC_{Ad} = [(h_{4A} - h_{3A}) + (h_{6A} - h_{5A})] + m_r[(h_{3R} - h_{2R})] \quad (21)$$

$$180 \quad CC_{Iso} = [T_{tank}(s_{5A} - s_{4A})] + m_r[T_{tank}(s_{4R} - s_{3R})] \quad (22)$$

181 Regarding the fourth cycle shown in Fig.4 where the LAir cycle derives two cascades Rankine cycles, the
 182 ratio of mass flow rate of the first closed Rankine cycle working fluid to the LAir mass flow rate (m_{r1}) was
 183 calculated using the energy balance in HE1 as in Eq.23, and ratio of mass flow rate of the second closed
 184 Rankine cycles working fluid to the LAir mass flow rate (m_{r2}) was calculated using the energy balance in HE2
 185 as in Eq.24

$$186 \quad m_{r1} = \frac{\dot{m}_R}{\dot{m}_A} = \frac{(h_{3A} - h_{2A})}{(h_{5R} - h_{1R})} \quad (23)$$

$$187 \quad m_{r2} = \frac{\dot{m}_{R'}}{\dot{m}_A} = \frac{m_{r1}(h_{3R} - h_{2R}) + (h_{4A} - h_{A3})}{(h_{4R'} - h_{1R'})} \quad (24)$$

188 Where; \dot{m}_R is the mass flow rate in kg/s for the first closed Rankine cycle and $\dot{m}_{R'}$ is the mass flow rate in kg/s
 189 for the second closed Rankine cycle. The subscripts R is referring to the first second closed Rankine cycle, while
 190 the subscript R' is referring to the second closed Rankine cycle.

191 The specific work output was calculated using Eqs.(25-28) when the adiabatic expansion process is considered
 192 and Eqs. (29-32) when the isothermal expansion process is considered.

$$193 \quad (W_A)_{Ad} = [(h_{5A} - h_{6A}) - (h_{2A} - h_{1A})] \quad (25)$$

$$194 \quad (W_R)_{Ad} = m_{r1}[(h_{4R} - h_{5R}) - (h_{2R} - h_{1R})] \quad (26)$$

$$195 \quad (W_{R'})_{Ad} = m_{r2}[(h_{3R'} - h_{4R'}) - (h_{2R'} - h_{1R'})] \quad (27)$$

$$196 \quad W_{Ad} = (W_A)_{Ad} + (W_R)_{Ad} + (W_{R'})_{Ad} \quad (28)$$

$$197 \quad (W_A)_{Iso} = T_{tank}(s_{6A} - s_{5A}) - (h_{2A} - h_{1A}) \quad (29)$$

$$198 \quad (W_R)_{Iso} = m_{r1}[T_{tank}(s_{5R} - s_{4R}) - (h_{2R} - h_{1R})] \quad (30)$$

$$199 \quad (W_{R'})_{Iso} = m_{r2}[T_{tank}(s_{4R'} - s_{3R'}) - (h_{2R'} - h_{1R'})] \quad (31)$$

$$200 \quad W_{Iso} = (W_A)_{Iso} + (W_R)_{Iso} + (W_{R'})_{Iso}$$

$$201 \quad (32)$$

202 The specific cooling capacity was calculated using Eq.33 when the adiabatic expansion process is considered
 203 and Eq.34 when the isothermal expansion process is considered.

$$204 \quad CC_{Ad} = [(h_{5A} - h_{4A}) + (h_{7A} - h_{6A})] + m_{r1}[(h_{3R} - h_{2R}) + m_{r2}[(h_{3R'} - h_{2R'})] \quad (29)$$

$$205 \quad CC_{Iso} = [T_{tank}(s_{5A} - s_{4A})] + m_{r1}[T_{tank}(s_{4R} - s_{3R})] + m_{r2}[T_{tank}(s_{4R'} - s_{3R'})] \quad (34)$$

206 The above cycles provide cooling and power which makes the system neither heat engine nor heat pump, so
 207 assessing the system performance seems different than normal systems. The study defined two different factors
 208 to evaluate the system performance; The first one is *COP* by considering the whole system as heat pump, in this
 209 case, the output power converted to an equivalent cooling capacity (which is a cooling produced using this
 210 output power to run a conventional AC system that has a COP of 3.5). Then the system COP was calculated
 211 based on the total cooling capacity and the energy consumed to produce LAir or LN2 as in using Eq.35 (which
 212 is 1080 kWh/kg for LAir and 1350 kWh/kg for LN2 (Ameel, 2013)) as in Eq.35.

$$213 \quad COP = \left[\frac{\text{Total cooling capacity}}{1080} \right]_{LAir} \quad \text{or} \quad COP = \left[\frac{\text{Total cooling capacity}}{1350} \right]_{LN2} \quad (35)$$

214 The second factor is *Recovery Efficiency* (η_{RE}) where the whole system considered as heat engine. In this
 215 case, the output cooling capacities were converted to an equivalent power (which is the input power needs to run
 216 a conventional AC system that has a COP of 3.5 to provide the same cooling capacity). Then the system
 217 *Recovery Efficiency* was calculated based on the total output power and the energy consumed to produce LAir or
 218 LN2 as in using Eq. 54.

$$219 \quad \eta_{RE} = \left[\frac{\text{Total output power}}{1080} \right]_{LAir} \quad \text{or} \quad \eta_{RE} = \left[\frac{\text{Total output power}}{1350} \right]_{LN2} \quad (36)$$

220 4- Results and discussion

221 The proposed cycles use to provide cooling and power to commercial buildings at the peak times leading to save
 222 energy and to reduce the electricity peak demands with more environment friendly solution. The above cycles
 223 were investigated using two different clod storage mediums LAir and LN2, which are having almost similar
 224 physical and thermodynamic properties, and the different requirements to produce each of them. LAir consumes
 225 20% less energy and less required components than that of LN2 needs and this will enhance the system
 226 performance significantly when LAir is used as the following results are showing;

227 Figs. 5-12 present specific output works, specific cooling capacities, the system COP and the system *Recovery*
 228 *Efficiency* for the adiabatic and the isothermal expansion processes for all proposed cycles either using LAir or
 229 LN2. For the adiabatic expansion scenario, the specific work vs the inlet pressure (P_{2A}) for all proposed cycles

230 presents in Fig.5 (a, b) where Fig.5a relates to LAir and Fig.5b relates to LN2. The figure shows the specific
231 output works have the same trend whether for the both working fluid (LAir or LN2) and there is no significant
232 change after a value of inlet pressure of 30 bar. The maximum power output for the 2nd, 3rd and 4th cycles
233 increases by 10.6%, 56.9% and 133.1% respectively compared with the first cycle when LAir is used and by
234 10.8% 54.8% and 129.5% consecutively when LN2 is used. The specific cooling capacities followed the same
235 output power trend as shown in Fig.6 (a, b) and compared to the first cycle, the maximum values of the cooling
236 capacities for 2nd, 3rd and 4th cycles show improvement by 3.0%, 15.2% and 36.8% when LAir is used and by
237 2.8%, 7.8% and 15.3% respectively when LN2 is used.

238 Regarding the isothermal expansion scenario, the specific output works and specific cooling capacities are
239 higher than that of adiabatic one as Fig.7 (a, b) and Fig.8 (a, b) shown. This expansion process allows the system
240 to increase the inlet pressure up to 500 bar or even more but after 300 bar there is no significant change
241 indicating no reason to increase the inlet pressure further. Compared with the adiabatic expansion, the output
242 works are increased by 3.1, 3.2, 2.6 and 2.0 times for the 1st, 2nd, 3rd and 4th cycles consecutively, when the
243 system uses LAir and almost the same values when LN2 is used. Also, compared with 1st cycle the specific
244 output works increased by 16.2%, 31.5%, 47.7% and for 2nd, 3rd and 4th respectively when LAir is used and by
245 13.7%, 32.5% and 48.4%, consecutively, when LN2 is used. The specific cooling capacities have almost the
246 same output work trend as shown in Fig.8 and their maximum values are 1.5, 1.5, 1.4 and 1.3 times that of the
247 adiabatic expansion for 1st, 2nd, 3rd and 4th cycles, consecutively,. Compared to the first cycle, the maximum
248 cooling capacities of the 2nd, 3rd and 4th cycles show improvement by 2.8%, 7.8% and 15% when, respectively,
249 LAir is used and 0%, 7.6% and 15%, consecutively, when LN2 is used.

250 The systems performance were assessed based on its *Recovery Efficiency* and COP as mentioned in section 3,
251 and for the adiabatic scenario, the *Recovery Efficiencies* and COPs of all proposed cycles are presented in Figs.
252 (9, 10) and their trends look similar to that of the output works. The figures indicate that the 4th cycle has highest
253 *Recovery Efficiency* and COP, and they reach 55% and 2, respectively, when LAir is used and 45% and 1.6,
254 consecutively, when LN2 is used. However, for the isothermal expansion scenario, the *Recovery Efficiencies*
255 and COPs of all proposed cycles are followed the output powers as shown in Figs. (11, 12). The figures show
256 that, the *Recovery Efficiency* and COP of the lowest system performance (1st cycle) reach 70% and 2.4,
257 respectively, when LAir is used and 55% and 1.9, respectively, when LN2 is used. However, in 4th cycle these
258 values reach 94% and 3.3, consecutively, when LAir is used and 78% and 2.7, consecutively, when LN2 is used.

259 The figures show clearly that, the systems *Recovery Efficiencies* and COPs when LAir is used are more than
 260 20% higher than that of when LN2 is used. The fourth shows the highest system performance while the 1st cycle
 261 shows the lowest.

262

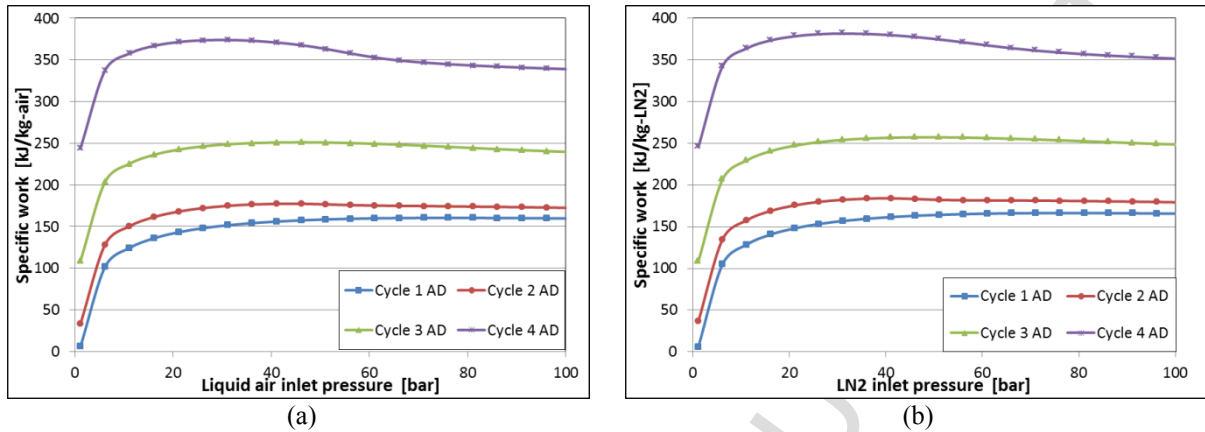

Fig.5 specific output work at various inlet pressure for the adiabatic expansion

263

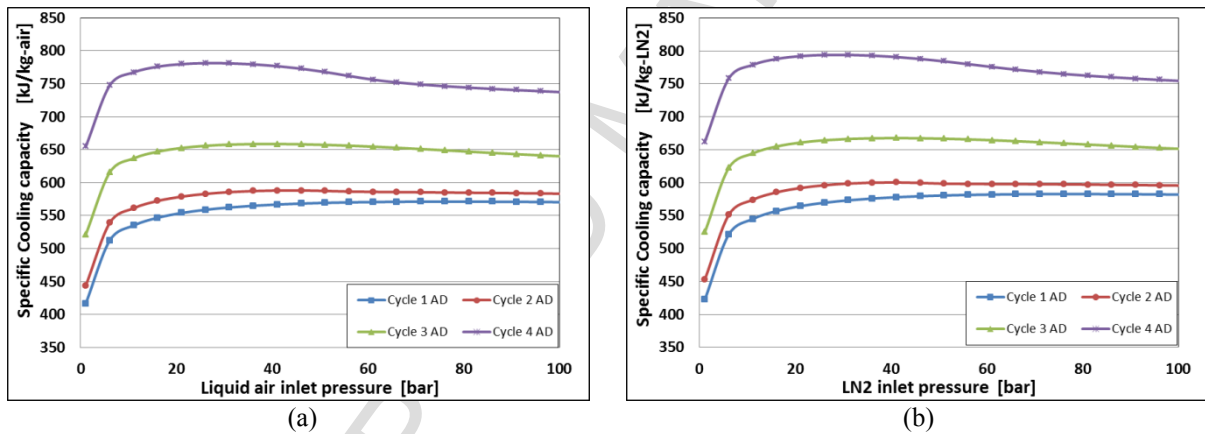

Fig.6 Specific cooling capacity at various inlet pressure for the adiabatic expansion

264

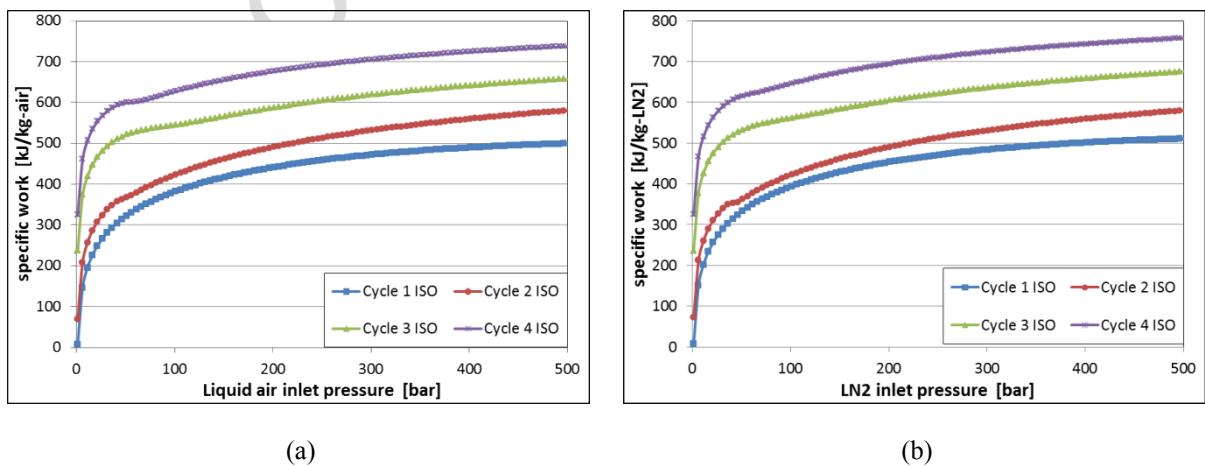

Fig.7 specific output work at various inlet pressure for the isothermal expansion

265

266

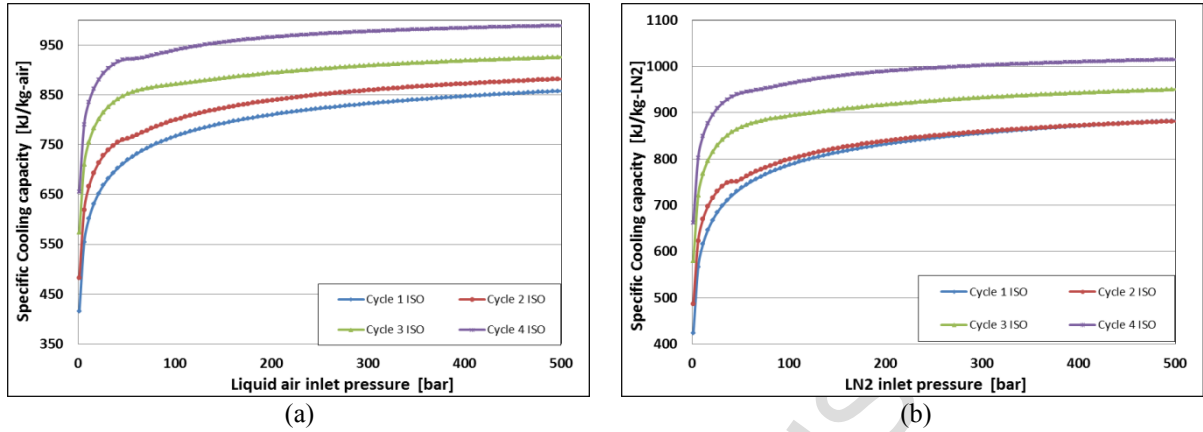

Fig.8 Specific cooling capacity at various inlet pressure for the adiabatic expansion

267

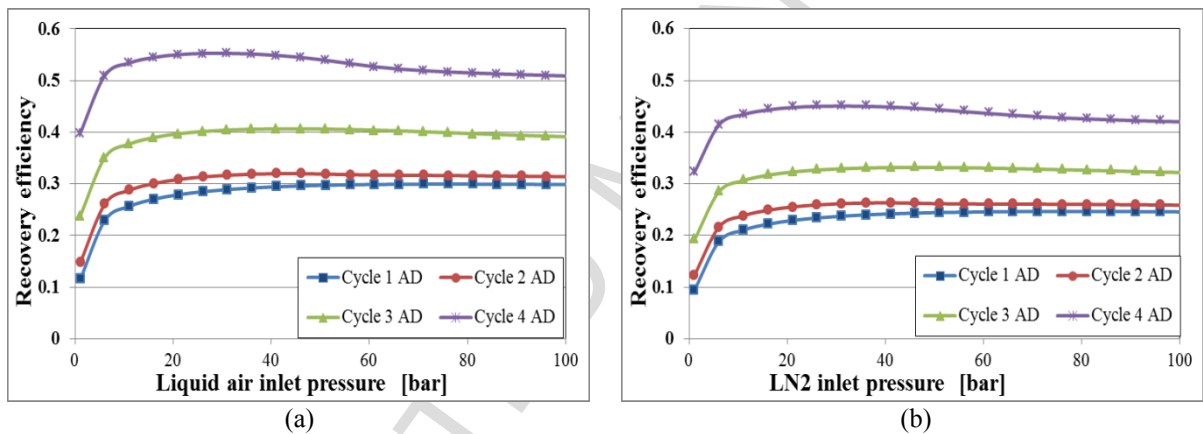

Fig.9 Recovery Efficiency at various inlet pressure for the adiabatic expansion

268

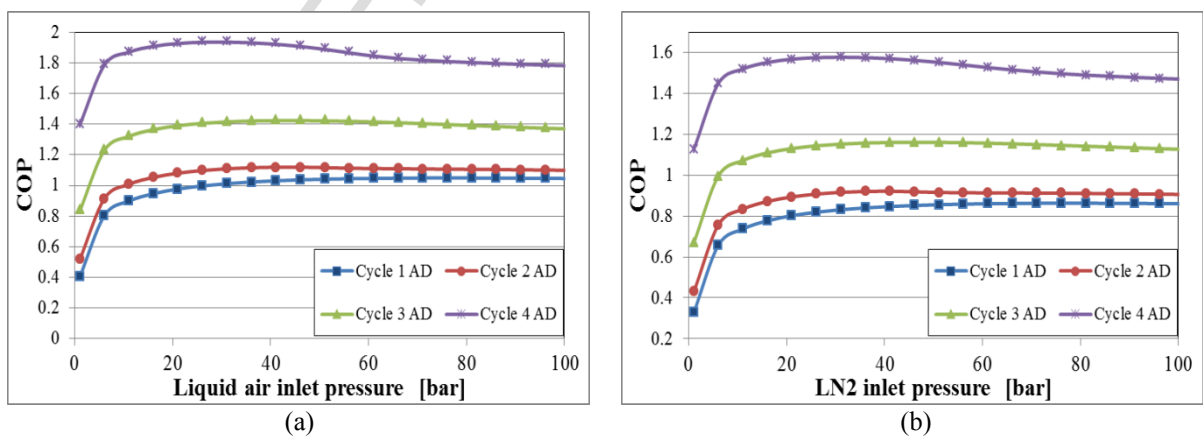

Fig.10 COP at various inlet pressure for the adiabatic expansion

269

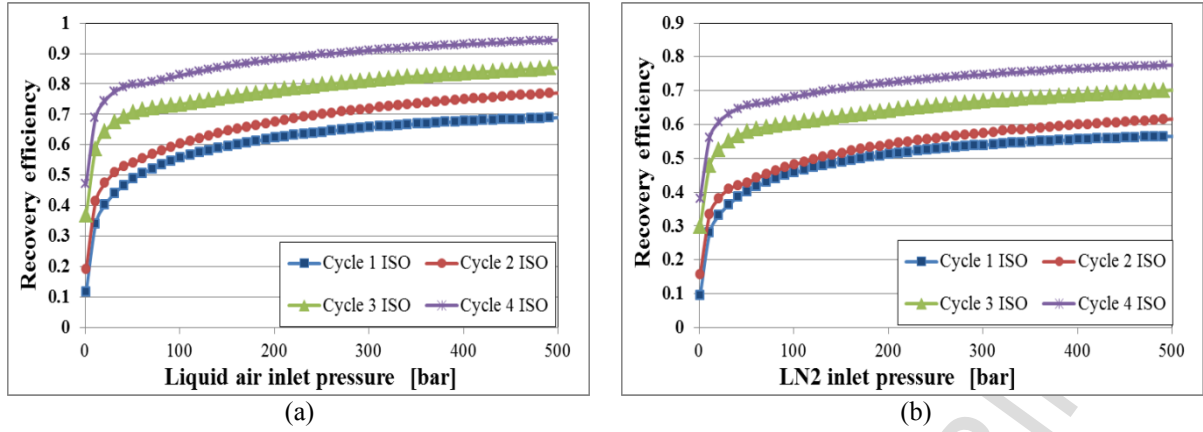

Fig.11 *Recovery Efficiency* at various inlet pressure for the isothermal expansion

270

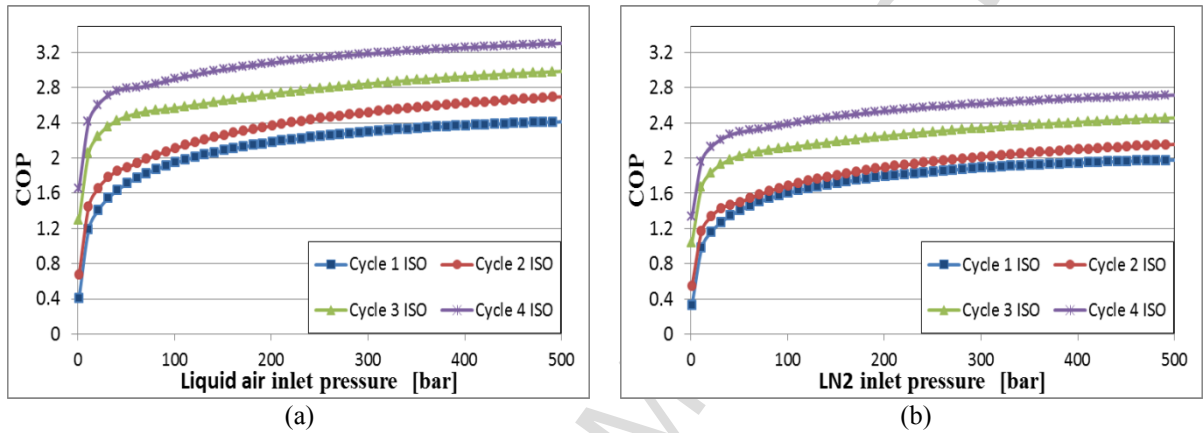

Fig.12 COP at various inlet pressure for the adiabatic expansion

271 Table 1 presents a comparison between LAir and LN2 when they use to fuel the proposed systems in terms of
 272 output work, cooling capacity, *Recovery Efficiency* and COP. The table shows in all cycles the output works and
 273 the cooling capacities are slightly higher when LN2 is used with difference less than 4%, however, the *Recovery*
 274 *Efficiencies* and the COPs are higher by 21-25% when LAir is used indicating using LAir is more efficient than
 275 LN2.

276 Table 1 comparison between of the proposed systems in terms of maximum work output, cooling capacity,
 277 *Recovery Efficiency* and COP when they the two different fluids (LAir and LN2).

Cycle No		Adiabatic Expansion				Isothermal Expansion			
		1	2	3	4	1	2	3	4
Max. specific power output	Air	160	177	251	373	499	580	656	737
	Nitrogen	166	184	257	381	510	580	676	757
Difference [%]		3.6	3.8	2.3	2.1	2.2	0.0	3.0	2.6
Max. specific cooling	Air	571	588	658	781	858	882	925	989
	Nitrogen	582	600	667	793	883	881	950	1015
Difference [%]		1.9	2.0	1.3	1.5	2.8	-0.1	2.6	2.6
Max. recovery efficiency [%]	Air	29.96	31.98	40.66	55.29	68.95	77.09	85.33	94.43
	Nitrogen	24.66	26.34	33.18	45.07	56.53	61.64	70.19	77.61
Difference [%]		21.5	21.4	22.5	22.7	22.0	25.1	21.6	21.7
Max. system COP	Air	1.05	1.12	1.42	1.93	2.41	2.69	2.98	3.3
	Nitrogen	0.86	0.92	1.16	1.57	1.97	2.15	2.45	2.71
Difference [%]		22.1	21.7	22.4	22.9	22.3	25.1	21.6	21.8

278

279 A commercial building located in Ahwaz, Iran was selected as case study to find out how much energy the
 280 proposed systems can save compared with the conventional AC systems, and the building cooling load is shown
 281 in Fig.13. The comparison was made based on the cost of the required LAir or LN2 or the conventional AC
 282 system power consumption to meet the building cooling load. The results are very sensitive to the LAir and LN2
 283 prices and at the current prices of LAir , LN2 and kWh electricity (Ahmad et ta., 2016) all above cycles in the
 284 isothermal expansion scenario consume less energy than the conventional system when LAir is used and only
 285 the 1st cycle consumes higher when LN2 is used as shown in Fig.14 (a, b). At this level of price the 1st, 2nd, 3rd
 286 and 4th cycles show savings up to 15%, 24%, 31% and 37.5%, respectively, when LAir is used, and -3.5%, 5%,
 287 16% and 24%, consecutively, when LN2 is used. Where the negative sign indicates there is no saving achieved
 288 in this cycle.

289 It has been reported that the widespread of this technology and using the co-located systems leads to further
 290 reduction in LAir and LN2 prices leading to further energy savings and further reduction in CO₂ emissions
 291 (Akhurst et al., 2013). Fig.15 present the energy cost saving of each the above cycles at three different LAir and
 292 LN2 prices (3.5, 2.5 and 1.5 pence per kg). The negative values mean the conventional AC system has less cost
 293 of energy consumption, and all of these values except one refer to the adiabatic expansion process which is
 294 practically difficult due to the heat gaining from the surround where the temperature is much higher than inside
 295 the system. At the lowest LAir and LN2 prices the 1st, 2nd, 3rd and 4th cycles show savings up to 63%, 67%, 70%
 296 and 72%, respectively, when LAir is used, and 55%, 59%, 63% and 67% , consecutively, when LN2 is used.
 297 And at this level of price, the 4th cycle, which is the more complex one among the investigated cycles, shows
 298 savings only 14%, 8% and 3% higher than the 1st, the 2nd and the 3rd cycles, respectively, indicating these is no
 299 point to use such complex system.

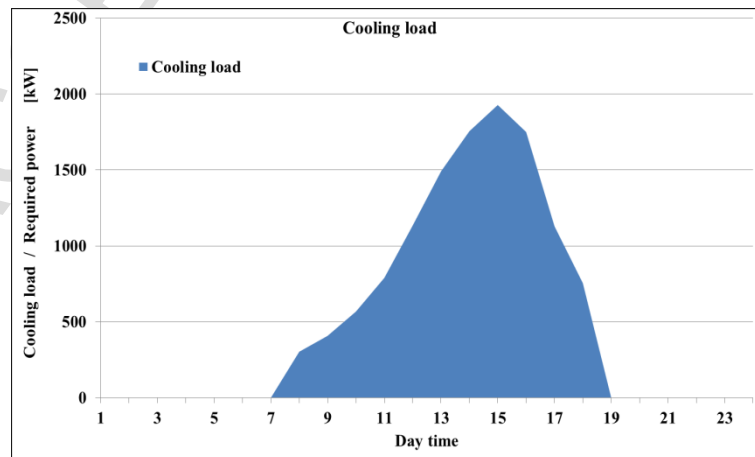
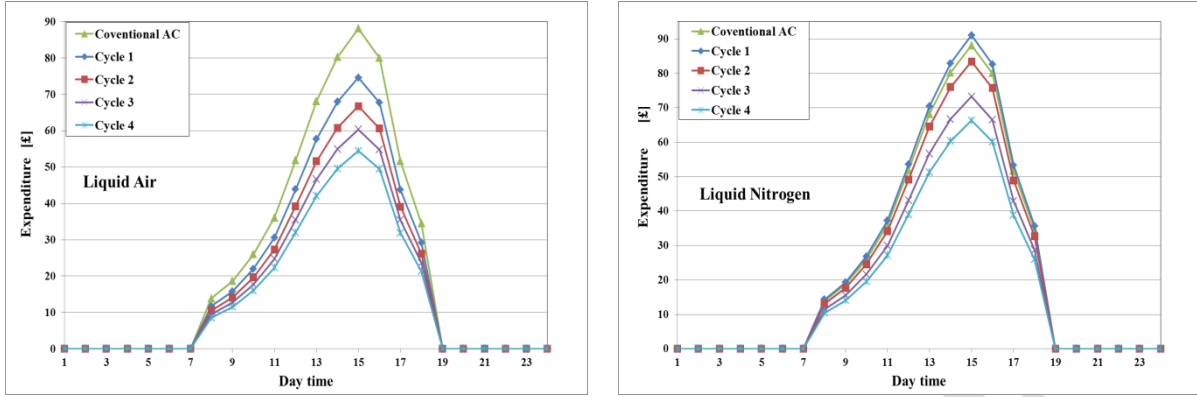

Fig.13. cooling load and the required power of the selected building (Navidbakhsh, et al., 2013)

300
301

302



(a) Liquid Air

(b) Liquid Nitrogen

Fig.14. Daily energy cost for the proposed cycles and conventional AC system

303

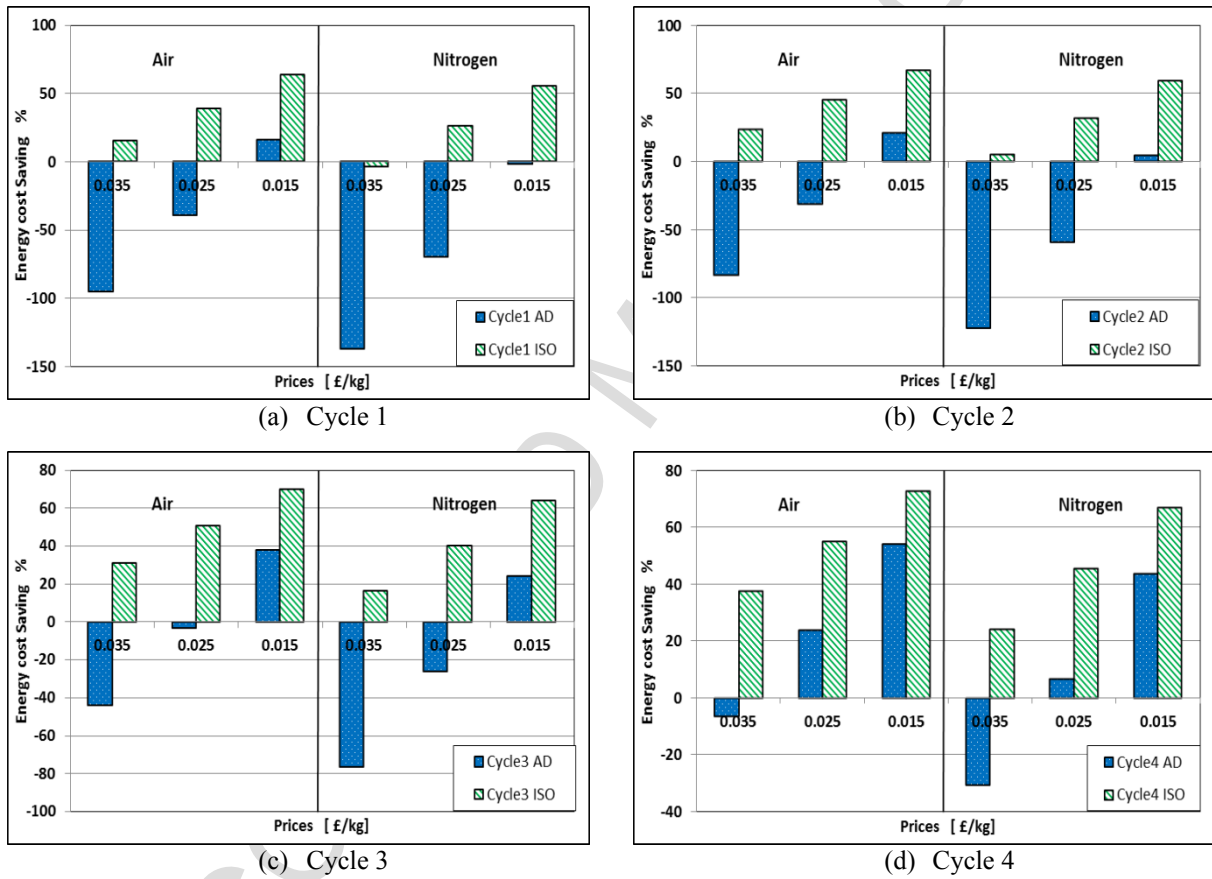

(a) Cycle 1

(b) Cycle 2

(c) Cycle 3

(d) Cycle 4

Fig.15. Saving of each proposed cycle against the conventional AC system

305 **5- Conclusions**

306 The conventional AC systems consume great amount of energy particularly during the peak times where the
 307 national electricity grid facing difficulties to meet the user's electricity demands. Consequently there is a need to
 308 modify the traditional AC systems or to produce new technology that leads to save energy, reduce the peak
 309 demands and reduce the CO₂ emissions. Cold energy storage in form of Liquid Air/N₂ is an attractive storage
 310 system and can be used to provide air conditioning and power. Four different cryogenic cycles use either LAir

311 or LN2 to provide cooling and power to a commercial building were investigated and compared with the
 312 conventional AC system and results showed that:

- 313 1- The 4th cycle showed the highest system performance, and it recovered up to 94% of the energy stored in
 314 LAir and up to 78% of the energy stored in LN2, also it showed cost saving of the energy consumption up
 315 73% when LAir is used and 67% when LN2 is used. However, the decisions about the selection of the
 316 most economical solution must take into consideration the complete design of the system including
 317 equipment sizing and investment costs.
- 318 2- LN2 system showed slightly higher (less than 4%) output works and the cooling capacities than LAir,
 319 however, LAir system showed 21-25% higher *Recovery Efficiency* and COP than LN2 due to its lower
 320 required energy to produce it.
- 321 3- Compared to the conventional system at the current LAir and LN2 prices the 1st, 2nd, 3rd and 4th cycles
 322 showed cost energy saving up to 15%, 24%, 31% and 37.5%, respectively, when LAir is used, and -
 323 3%, 5%, 16% and 24%, consecutively, when LN2 is used.
- 324 4- Extensive of using this technology leads to further reduction in the LAir and LN2 prices, and results
 325 showed that, at price level of 1.5 pence kg-LAir/LN2 the 1st, 2nd, 3rd and 4th cycles saved up to 63%,
 326 67%, 70% and 72%, respectively when LAir is used, and 55%, 59%, 63% and 67%, consecutively
 327 when LN2 is used, leading to use the simplest cycle.

Nomenclature	Subscripts
h enthalpy kJ/kg	A Liquid air cycle
CC specific cooling capacity kW/kg-LAir	B Brayton cycle
\dot{m} mass flow rate kg/s	Ad Adiabatic expansion
s entropy kJ/kg.K	Iso Isothermal expansion
W specific power kW/kg-LAir	R Closed Rankin cycle/first closed Rankin cycle
m_r the closed Brayton or Rankin cycles mass flow rates to LAir mass flow rate	R' Second closed Rankin cycle
m_{r1} the first closed Rankin cycle mass flow rate to LAir mass flow rate	$tank$ Cooling tank
m_{r2} the second closed Rankin cycle mass flow rate to LAir mass flow rate	

328

329 Acknowledgment

330 The author thanks the University of Sebha and the Ministry of Higher Education and scientific research in Libya
 331 for funding may PhD study.

332

333 **References**

- 334 Ahmad, A., Al-Dadah, R. and Mahmoud, S., 2016. Liquid nitrogen energy storage for air conditioning and
 335 power generation in domestic applications. *Energy Conversion and Management*, 128, pp.34-43.
- 336 Ahmad, A.Y., Raya, A.D. and Mahmoud, S., 2016, October. Liquid nitrogen air conditioning system for
 337 domestic application. In *Students on Applied Engineering (ISCAE), International Conference for* (pp. 291-
 338 296). IEEE.
- 339 Ahmad, Abdalqader, Raya Al-Dadah, and Saad Mahmoud. "Air conditioning and power generation for
 340 residential applications using liquid nitrogen." *Applied Energy* 184 (2016): 630-640.
- 341 Akhurst, M., I. Arbon, M. Ayres, N. Brandon, R. Bruges, S. Cooper, Y. Ding et al. "Liquid Air in the energy
 342 and transport systems: opportunities for industry and innovation in the UK." (2013).
- 343 Ameel B, T'Joel C, De Kerpel K, De Jaeger P, Huisseune H, Van Belleghem M, De Paepe M. Thermodynamic
 344 analysis of energy storage with a liquid air Rankine cycle. *Applied Thermal Engineering*. 2013 Apr
 345 5;52(1):130-40.
- 346 Cox S. Cooling a warming planet: A global air conditioning surge. *Yale Environment*. 2012;360(10).
- 347 Davis LW, Gertler PJ. Contribution of air conditioning adoption to future energy use under global warming.
 348 *Proceedings of the National Academy of Sciences*. 2015;112(19):5962-7.
- 349 Dearman, 2015, *Liquid Air on the European Highway, The economic and environmental impact of zero-*
 350 *emission transport refrigeration*, [accessed on 17/02/2017],
- 351 Garlov, Roland, Vladymyr Saveliev, Konstantin Gavrylov, Leonid Golovin, and Howard Pedolsky.
 352 "Refrigeration of a food transport vehicle utilizing liquid nitrogen." U.S. Patent 6,345,509, issued February
 353 12, 2002.
- 354 Giasin, K., S. Ayvar-Soberanis, and A. Hodzic. "Evaluation of cryogenic cooling and minimum quantity
 355 lubrication effects on machining GLARE laminates using design of experiments." *Journal of Cleaner*
 356 *Production* 135 (2016): 533-548.
- 357 Harold, R., Fairchild Engine & Airplane, 1960. Air conditioning system. U.S. Patent 2,943,459.
- 358 Knowlen C, Williams J, Mattick A, Deparis H, Hertzberg A. Quasi-isothermal expansion engines for liquid
 359 nitrogen automotive propulsion. SAE Technical Paper, 1997 0148-7191.
- 360 Knowlen C, Mattick A, Bruckner AP, Hertzberg A. High efficiency energy conversion systems for liquid
 361 nitrogen automobiles. SAE Technical Paper, 1998 0148-7191.
- 362 Lemmon, E.W., Huber, M.L. and McLinden, M.O., NIST Standard Reference Database 23: reference fluid
 363 thermodynamic and transport properties REFPROP. 2010; Version 9.0. National Institute of Standards and
 364 Technology, Standard Reference Data Program, Gaithersburg, Maryland.
- 365 MATLAB, TM. "version 7.7. 0 (R2008b)." The MathWorks Inc., Natick, Massachusetts (2008).
- 366 Navidbakhsh, Mahdi, Ali Shirazi, and Sepehr Sanaye. "Four E analysis and multi-objective optimization of an
 367 ice storage system incorporating PCM as the partial cold storage for air-conditioning applications."
 368 *Applied Thermal Engineering* 58.1 (2013): 30-41.
- 369 Navidbakhsh, Mahdi, Ali Shirazi, and Sepehr Sanaye. "Four E analysis and multi-objective optimization of an
 370 ice storage system incorporating PCM as the partial cold storage for air-conditioning applications."
 371 *Applied Thermal Engineering* 58, no. 1 (2013): 30-41.
- 372 Newman, Michael D., and Stephen A. McCormick. "LNG (liquefied natural gas) and LIN (liquid nitrogen) in
 373 transit refrigeration heat exchange system." U.S. Patent No. 8,763,409. 1 Jul. 2014.
- 374 North TB. *Liquid Nitrogen Propulsion Systems for Automotive Applications: Calculation of the Mechanical*
 375 *Efficiency of a Dual, Double-acting Piston Propulsion System*: ProQuest; 2008.
- 376 Ordonez C. Liquid nitrogen fueled, closed Brayton cycle cryogenic heat engine. *Energy Conversion and*
 377 *Management*. 2000;41(4):331-41.
- 378 Pereira, O., et al. "Cryogenic and minimum quantity lubrication for an eco-efficiency turning of AISI 304."
 379 *Journal of Cleaner Production* 139 (2016): 440-449.
- 380 Place, James F. "Apparatus for cooling and preserving foods, &c., by liquid air." U.S. Patent No. 927,595. 13
 381 Jul. 1909.
- 382 Saia III, Louis P., and Cynthia S. Wilbrandt. "Portable self-contained cooler/freezer apparatus for use on
 383 airplanes, common carrier type unrefrigerated truck lines, and the like." U.S. Patent No. 5,337,579. 16
 384 Aug. 1994.
- 385 Skobel, Robert M., and Daniel Davey. "Liquid nitrogen cooled beverage dispenser." U.S. Patent Application
 386 13/571,196, filed November 29, 2012.
- 387 Strahan D, Akhurst M, Atkins A. *Liquid Air in the Energy and Transport Systems: Opportunities for Industry*
 388 *and Innovation in the UK*. Centre for Low Carbon Futures report. 2013(020).

- 389 Tazehkandi, Ahmadreza Hosseini, Mohammadreza Shabgard, and Farid Pilehvarian. "Application of liquid
390 nitrogen and spray mode of biodegradable vegetable cutting fluid with compressed air in order to reduce
391 cutting fluid consumption in turning Inconel 740." *Journal of Cleaner Production* 108 (2015): 90-103
392 Vitt, Peter D. Operational characteristics of a liquid nitrogen powered automobile. No. TR-98-041. Washington
393 Univ Seattle Dept Of Aeronautics And Astronautics, 1998.
394 Zhai, X. Q., X. L. Wang, T. Wang, and R. Z. Wang. "A review on phase change cold storage in air-conditioning
395 system: materials and applications." *Renewable and Sustainable Energy Reviews* 22 (2013): 108-120.
396