

## IOP Conference Series: Materials Science and Engineering

---

PAPER • **OPEN ACCESS**

# Passive Slug Attenuation Device: Potential and Operability

To cite this article: Ajobola T Ogunbiyi *et al* 2018 *IOP Conf. Ser.: Mater. Sci. Eng.* **413** 012005

View the [article online](#) for updates and enhancements.



**IOP** | ebooks™

Bringing you innovative digital publishing with leading voices to create your essential collection of books in STEM research.

Start exploring the [collection](#) - download the first chapter of every title for free.

# Passive Slug Attenuation Device: Potential and Operability

Ajibola T Ogunbiyi <sup>1,3</sup> ; Adegboyega B Ehinmowo <sup>1,2</sup> ; Samuel E Sanni <sup>3</sup> ; Hoi Yeung <sup>1</sup>

<sup>1</sup>Oil & Gas Engineering Centre, Cranfield University, Bedfordshire, MK43 0AL, United Kingdom.

<sup>2</sup>Department of Chemical and Petroleum Engineering, University of Lagos, Akoka, Yaba, Lagos, Nigeria.

<sup>3</sup>Department of Chemical Engineering, Covenant University, Canaanland, km 10, Idiroko Road, Ota, Nigeria.

Email: [ahinmowo@unilag.edu.ng](mailto:ahinmowo@unilag.edu.ng)

**Abstract** Over the years, there have been some concerted efforts towards developing techniques to mitigate the threat posed by slugs to oil and gas production systems. Passive slug attenuation devices have been known to show promising potential in this regard but can generally be confronted with operability issues. In this study, experimental investigation on the hydrodynamic slug attenuation potential and the operability of a process-intensified passive slug control device- Pseudo Spiral Tube (PST) was carried out. The result showed that the device possesses the capability to partially attenuate slug flow. This was achieved with the help of the swirl flow generated within the device which helps achieve air entrainments in the liquid slug leading to reduction in the effective density of the liquid slug. The results showed that the slug severity was reduced by 24% for the case studied. However, the slug redeveloped few meters downstream the device. Therefore, in order to achieve maximum slug attenuation, the device should be installed immediately upstream the topside separator. It was also observed that the pipeline might be pigged with the device installed. However, during multiphase flows, the pig may get stuck intermittently in the device. Hence, it was conceived that a flexible pig could be more appropriate to overcome this challenge.

Keyword: Passive slug control, pigging, Pseudo spiral tube, Operability, swirl flow; multiphase flow

## 1 Introduction

### 1.1 Slug flow in multiphase pipeline-riser systems

In oil and gas industry, liquid and gas are usually transported using a single pipeline. This multiphase transport results to a number of flow assurance challenges and one of such is slug flow. Slug flow belongs to intermittent flow regime characterised by unsteady flow of liquid and gas that manifests in pressure and flow fluctuations. This intermittent behaviour has the potential for pipeline damage, separator trip off and hence, a negative impact on production. Three types of slugging are widely identified: hydrodynamic, terrain/severe, and operation-induced slugging.

Severe/Terrain induced slugging has been known to be of concern to the petroleum industry and several authors have investigated this phenomenon and proffered a number of solutions [1, 2, 3, 4, 5]. Others proposed stability criteria and some further classified severe slugging into classical severe slugging, transitional, oscillation flow etc.[2, 6, 7, 8, 9, 10, 11, 12].

Severe slug flow is known to characteristically manifest in large pressure and flow rate fluctuation leading to poor performance of separators, pipeline fatigue, and sometimes, eventual plant shutdown. It has been reported that as production activities shift to deep and ultra-deep offshore, the effect of severe slugging may become more heightened [13].



Operation-induced slug flow is the type of slugging due to various operational changes such as pigging operations, flow ramp up, system depressurization and restart. The aforementioned operations usually generate a large liquid volume flowing intermittently and received in the topside facility in form of slugs.

Hydrodynamic slug flow is another type of slug flow usually encountered in multiphase pipelines. This kind of slug is generally believed to be of high frequency and is short in length. This phenomenon has been previously studied by some authors and proposed models for its prediction [14-16]. Other researchers including *Issa et al.* [17] have also investigated the characteristics of hydrodynamic slug but only little has been done on its attenuation till date. Hydrodynamic slugging has been reported to possess the tendency to cause problems in pipeline-riser systems [1, 18, 19, 20]. There is therefore the need to investigate possible ways of attenuating it.

The control/attenuation of the first two classes of slug flow has been well researched by many authors. Control systems or devices slug attenuation capability are well documented in Literature. In 2011, *Xing* broadly classified these attenuation techniques into passive and active methods. Passive slug mitigation techniques are ‘‘self-acting’’ methods that attenuate slug flow without any external influence [11]. On the other hand, active methods require an external influencer to perform the slug attenuation function. Gas lift, subsea separation, slug catcher, choking (manual and automated) are some of the techniques currently adopted [21-23].

Many of these techniques have been deployed successfully in the industry but there are still few areas that need further attention. Gas lift/injection for example can require huge cost for implementation while the need for an appropriate model for the controller design is typically an issue for automated slug control system. Multiphase slug flow is a complex phenomenon and its modelling can be tasking. Many existing phenomenological models are simplified to be able to meet controller design requirements and usually tuned for specific conditions [24, 25], hence the predictive capability of such models are therefore limited. Also, the controllable measurements which usually include downhole and riser base measurements are not easily obtained. Controllers are usually designed to operate within a limited range (envelope), which means that the back pressure imposed by the choke might not be substantially reduced. Although recently, few studies have been done in some of these areas, there is still the need to further attend to these issues for improved oil production.

Notable progress has been made in the research on passive slug mitigation methods and some success reported from field trials conducted on these devices. For instance, various reports show that passive slug mitigation could be achieved by design modification, riser base mixer [26], slug catcher [27], the use of flow conditioner in the pipeline [22, 28, 29-32], venturi device [34], self-gas lifting method [35, 36], the bubble breaker [37] and the intermittent absorber [12]. The performance of many of these devices however, may be undermined due to operability issues.

## 1.2 Swirl flow and application

Swirl flow is one of the important drivers of process intensification. It has been widely applied in various industries including process engineering, automobile and environment. Some of the areas of applications include cyclone separators, turbo machinery and pollution control. In separation process, for example, swirl flow helps in drastic size reduction of separators as compared with the scenario in gravity separators [38].

Many authors have investigated various aspects of swirl flow generation, decay and applications. In 2015, *Rocha* and his team, for example, reviewed various swirl generators and revealed the need for the optimization of their geometries [39]. Some of the issues raised include their intrusive nature, maintenance, and potential increase in pressure drop due to flow reversal. Swirl flow decay has been investigated by many authors such as *Najafi et al.*, (2011) [40]. For flow applications, *Yeung and Cao*, in 2007, proposed the device investigated in this work for severe slug flow attenuation, building on the

work carried out by *Adedigba* in the same year[41]. In this paper, the hydrodynamic slug attenuation potential of the device and its effect on pigging operation were investigated.

### 1.3 Pigging

Pigging is one of the cardinal operations in the oil and gas industry. The procedure is usually employed for pipeline inspection and maintenance. This is achieved with the help of pigs, pig launcher, pig receiver and a flow medium which provides the driving force for the pigs. There are various pig designs which could be broadly categorised as gel pigs, utility pigs and inspection pigs [42, 43]. The various types of pigs, and operation have been well documented in the work of *Cordell and Vanzant* written in 2003 [44]. The study investigated pigging operation in a passive slug attenuation device- Pseudo Spiral Tube (PST).

### 2.0 Experimental Study

The experimental setup for this study is shown in Figure 1. It is one of the horizontal multiphase facilities located in Cranfield University's Oil and Gas Centre. Air flowed in from the central compressors into the metering section via a needle valve. A gas turbine flow meter with a maximum scale of 60 m<sup>3</sup>/h ( $\pm 1\%$ ) was used for gas flow measurement, while pressure transducers of 0-6 barg range ( $\pm 0.25\%$ ) and thermocouples of 0-100 °C range ( $\pm 1\%$ ) were used for the pressure and temperature measurements respectively, at the gas metering section. Water was supplied from a 4.4 m<sup>3</sup> water tank to the experimental rig by means of a centrifugal pump with a maximum capacity of 40 m<sup>3</sup>/h at a 5 barg discharge pressure. This supply to and from the tank was done via a bypass line. An electromagnetic flow meter with a range of 0-4.524 m<sup>3</sup>/h (with a  $\pm 1\%$  uncertainty) was used to measure the flow rate of water.

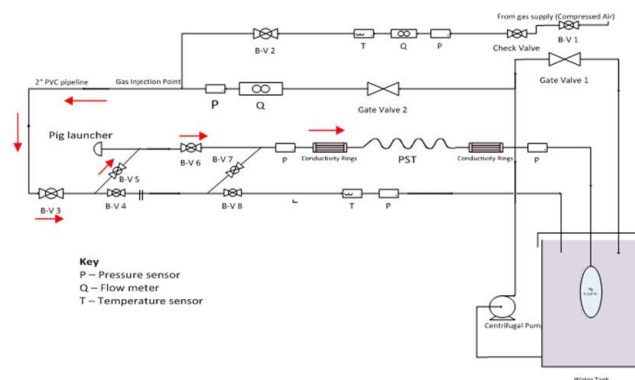

Fig. 1 Schematic of experimental set up

### 2.1 Experimental procedure on slug attenuation potential of the PST

The passive slug mitigation device (PST) investigated in the study constituted the test section. A number of standard piping elbows joined together in series (end to end) at a particular angle of twist between adjacent elbows, forms the PST. Hence, the geometry of PST is dependent on the elbow's internal angle, the elbow's radius to pipe diameter ratio and the angle of twist between adjacent elbows, as shown in Figures 2a and 2b.



Fig. 2a Test section showing the PST and the conductivity rings

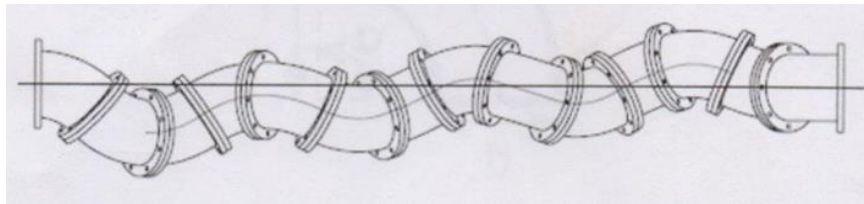

Fig. 2b Schematic diagram of the PST

The design of this device has been documented in a paper by *Yeung and Cao* [41]. The two-phase flow characteristics were observed both at upstream and downstream sections of the test section. Valuable information gathered from the experimental rig include slug attenuation potential of the PST and the generation of flow regime map. The procedure adopted for this work has been reported in the work of *Ogunbiyi* [45].

**2.2 Experimental procedure on pigging operation through the device**

One of the objectives of this study was to investigate the operability of the proposed passive slug attenuation device. This section describes the pigging studies carried out to meet the desired objective. Figure 3 shows a section of the experimental rig and Figure 4 shows the model pigs used in this study.



Fig. 3 Pictorial view of the experimental rig

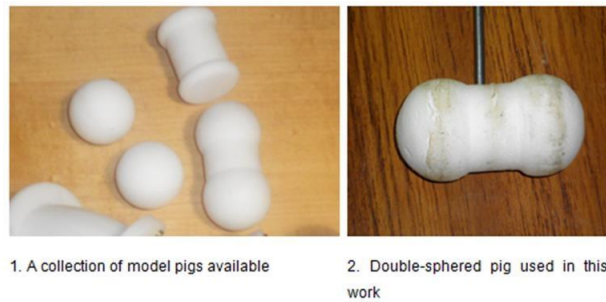

Fig. 4 Model pigs used for the pigging study

The various pigs were used for preliminary investigations of the pigging potential of the passive device. After preliminary studies, the double-sphere shaped pig was observed to perform better than other types and was subsequently used in this study. The model pig had a length of about 8.6 cm with equal width of about 4.1 cm each at both ends.

The pigging operation was carried out under two conditions. The first involved driving the pig using single phase (water) flow while the second was done using two-phase air-water flow. During pigging operation, the system response was monitored using readings from the conductivity rings, visual inspection and display on the high speed camera. The liquid holdup characteristics of the flow at the entrance and exit of the PST were compared in order to understand the phenomenological changes that occurred during each run. The velocity of the pig was computed for each run and compared with the fluid’s velocity which is a critical factor for slug formation. Detailed procedure of the pigging operation has been documented in *Ogunbiyi* [45].

### 3 Results and discussion

#### 3.1 Slug flow attenuation potential of Pseudo Spiral Tube (PST)

An experimental matrix covering both slugging and non-slugging regimes was investigated with special interest in the slugging region.

The flow regimes obtained compared well with that of *Mandhane et al.* [46] as shown in Figure 5. However, few conditions existed where slug flow observed appeared on non-slug region on the *Mandhane’s* map, this could be traced to pipeline diameter and geometry difference. Representative slug flow conditions were further investigated for possible attenuation by the PST and the results are presented.

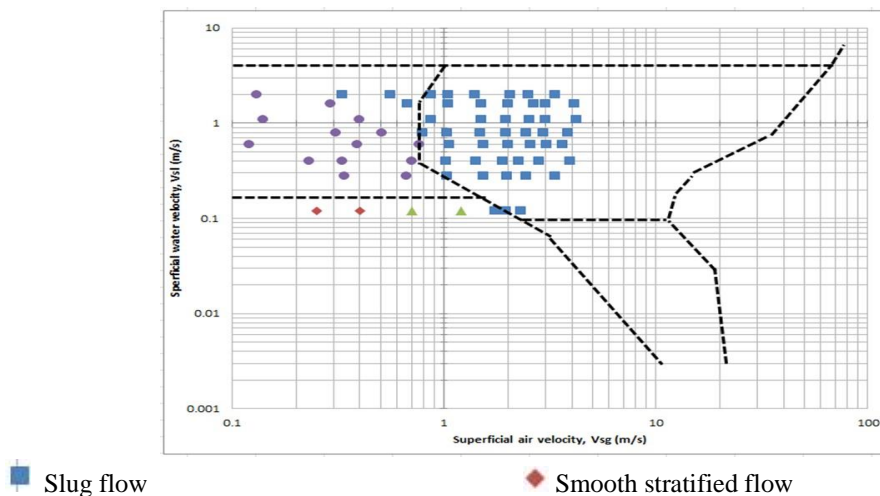

- Elongated bubble flow
- ▲ Wavy stratified flow

Fig. 5 Comparison between the flow regime observed and that by Mandhane *et al.* (1974)

Figure 6 shows the liquid holdup response of a representative slug flow condition investigated. This was at a liquid superficial velocity of 0.99 m/s and air superficial velocity of 1.02 m/s.

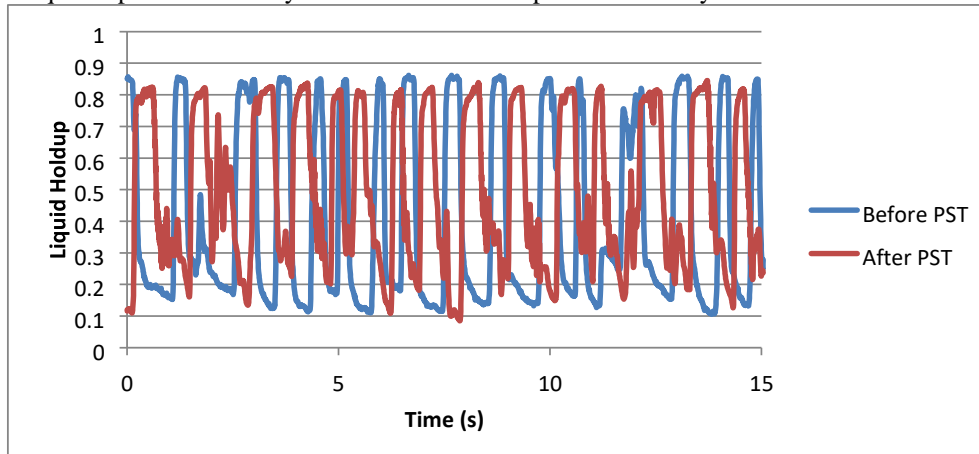

Fig. 6 Slug attenuation impact of PST at 0.99 m/s  $V_{sl}$  and 1.02 m/s  $V_{sg}$

The liquid holdup time response and visual observation confirmed slug flow at upstream and downstream the device (PST). However, the amplitude of the slug was observed to have decreased at the downstream compared with that at the upstream section of the PST. This shows that the slug characteristics was slightly altered by the PST.

Other representative slug flow conditions investigated showed that slug flow occurred around downstream and upstream sections of the device and similar trend as shown in Figure 6 were observed. This suggests that the PST provides partial slug attenuation and not a total attenuation.

The slug attenuation (SA) [12] index can be defined for the PST as

$$SA = \left[ \frac{(Magnitude\ of\ fluctuation)_{upstream} - (Magnitude\ of\ fluctuation)_{downstream}}{(Magnitude\ of\ fluctuation)_{upstream}} \right] \quad (1)$$

The magnitude of fluctuation can be estimated using simple arithmetic range or standard deviation of the data. For the case studied for example, the slug attenuation (SA) was 0.24. This implies that the intensity/severity of the slug had been reduced by 24%. This is in agreement with previous studies on passive slug attenuation device even though the PST design in this work (sixteen 45-degree elbows with an angle of twist of 90°) is not exactly the same as that used in Xing’s work of 2011 [5, 11, 12]. This slug attenuation was made possible as a result of the swirl flow generated by the geometry of the PST. The swirl helped achieve air entrainments in the liquid slug body leading to reduction in the effective density of the liquid slug.

### 3.2 Pigging of the PST

The main focus here was on the ability to pig the pipeline when the PST is installed. As discussed in section 1.2, the device has previously been reported to possess potential for severe slug flow attenuation. However, it was not clear if the device would cause operational setbacks when installed on a

pipelineriser system. This section presents the results on pigging operation of the PST. Single-phase pigging of the PST.

The characterisation of the flow of the pig through the PST was done using the liquid holdup obtained at the upstream and downstream conductivity rings.

**3.2.1 Single phase (Water) pigging operation through the PST**

Figure 7 shows the liquid holdup plots at the upstream and downstream sections of the device (PST) using only water (single phase pigging operation) at a velocity of 0.56 m/s.

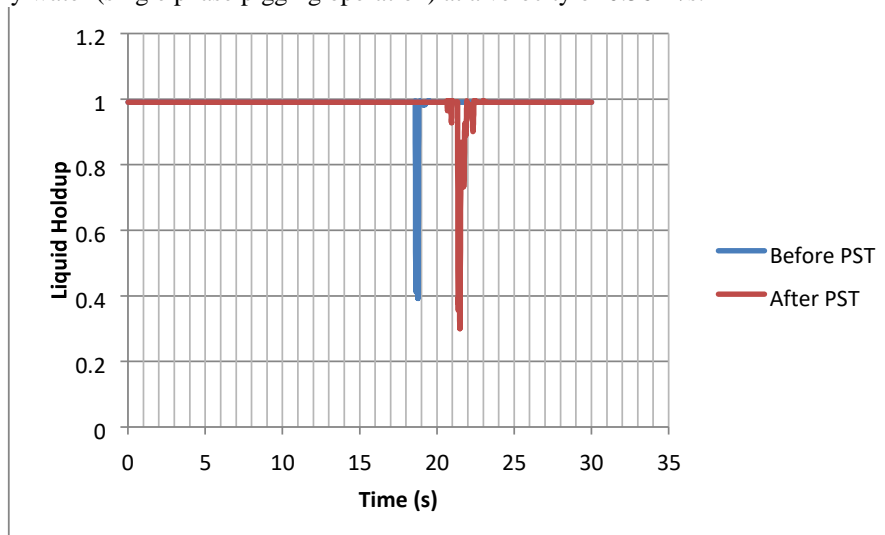

Fig. 7 Time traces of liquid holdup at a liquid superficial velocity of 0.56 m/s

Figure 7 shows that, prior to the arrival of the pig at the entrance of the PST, the pipe was fully filled with water as represented by liquid holdup of 1.0 until at 18.5 s when a sharp drop in the liquid holdup to 0.4 signalled the pig’s arrival at the PST. As the pig moved past this point, there was a sharp rise in the liquid holdup back to 1.0. Similarly, at the second conductivity ring, the liquid hold-up again dropped from 1.0 to 0.3 at 22 s. It was observed however, that the liquid holdup did not drop to zero. This was as a result of the water surrounding the pig body and may also be traced to leakage between the pig and the pipe wall. For this case, the pig was observed to spend 4.06 s in the PST.

The results above show a similar trend with experimental studies for water superficial velocities of 0.80, 1.06, 1.28, 1.47, 1.58, 2.11 and 2.37 m/s and summary of the results are shown in Table 1. The liquid holdup time response taken at upstream and downstream of the device at these liquid superficial velocities were all similar to that shown in Figure 7.

Table 1 Variation of average pig velocity with pig’s residence time in PST

Superficial Ring 2 (s) Ring 1 to (m/s)	Time at Time in (m/s)	Time at Time in (m/s)	Resident between of Pig velocity, Vsl	Length Velocity Water Ring 1 (s) PST (s)	Ring 2 (m)
0.56	17.88	21.94	4.06	1.21	0.30
0.80	15.68	17.82	2.14	1.21	0.57
1.06	12.89	14.25	1.36	1.21	0.85



1.28	12.07	13.50	1.43	1.21	0.85
1.47	10.94	12.04	1.10	1.21	1.1
1.58	10.64	11.74	1.10	1.21	1.1
2.11	9.03	9.90	0.87	1.21	1.39
2.37	9.69	10.32	0.63	1.21	1.92

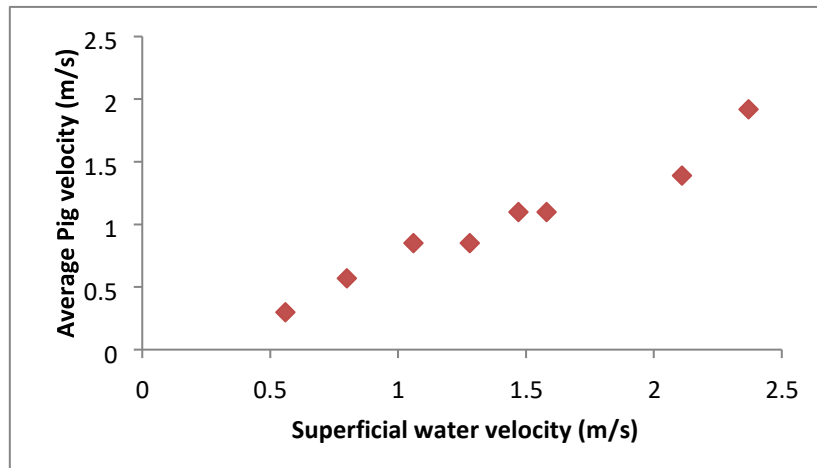

Fig. 8 Variation of average pig velocity with superficial water velocity

Table 1 presents the summary of the results of eight (8) experimental studies on single phase pigging. An interesting observation here was the relationship between the pig's and superficial liquid velocities. Expectedly, the pig was to travel at the liquid superficial velocity but this was not the case; instead, it travelled at a velocity less than this. This discrepancy could be traceable to resistances in terms of drag force caused by the seepage of water through narrow clearances between the pig and pipe walls, and friction between the pig and the internal walls of the pipeline. Figure 8 shows the plot of average pig's velocity against the superficial velocity of the carrier fluid. The pig velocity increased with the liquid superficial velocity in a near linear manner.

### 3.2.2 Two- phase (Air-Water) pigging through the PST

Figure 9 shows the progress of a pig downstream the device (PST) when  $(V_{sl}, V_{sg}) = (0.80 \text{ m/s}, 0.27 \text{ m/s})$ . Here, air-water, two-phase flow provided the driving force for the pig. Downstream the pig, a bubbly flow (bubble-laden water) regime was observed. At lower velocities, little or no liquid was observed to flow behind the pig while travelling through the second conductivity ring leading to a zero or near zero liquid holdup as shown in Figure 9(c) and (d). It was also observed that sufficient air flow temporarily transports the pig through before the arrival of the new cycle of liquid flow. The intermittency is a known characteristics of slug flow.

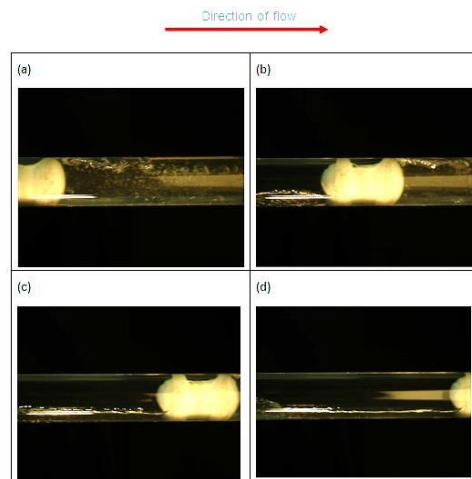

Fig. 9 Movement of a pig downstream the PST at  $(V_{sl}, V_{sg}) = (0.80 \text{ m/s}, 0.27 \text{ m/s})$

The upstream and downstream liquid hold up time response are shown in Figure 10. Elongated bubble flow was initially observed before point A where operational induced slug flow ensued. At point B, a liquid holdup of zero was recorded for about 8 s which marked the time when the pig was at the first conductivity ring. A rise in the liquid holdup was observed at point D as liquid re-entered the device (PST). The pig was observed to exit the device at Point C and a period of no liquid flow was observed as shown between C and D. This intermittent flow of liquid and gas flow is primarily a characteristics of slug flow as observed for an operation (pigging) induced slug flow. It was observed that the pig's resident time (time between points B and C) in the PST was much smaller than that spent during the single-phase pigging operation. This can be explained by the difference in magnitude between the mixture velocity and single phase flow velocity. At sufficiently high flow rates, turbulence is expected to enhance the flow of pig. Similar trends/results were observed for other conditions investigated but not reported in this paper. Thus, the interaction between the three-phases - water, air and pig - played an important role in determining the flow behaviour at the entry point of the pig into the PST. Different flow patterns were observed for various flow conditions.

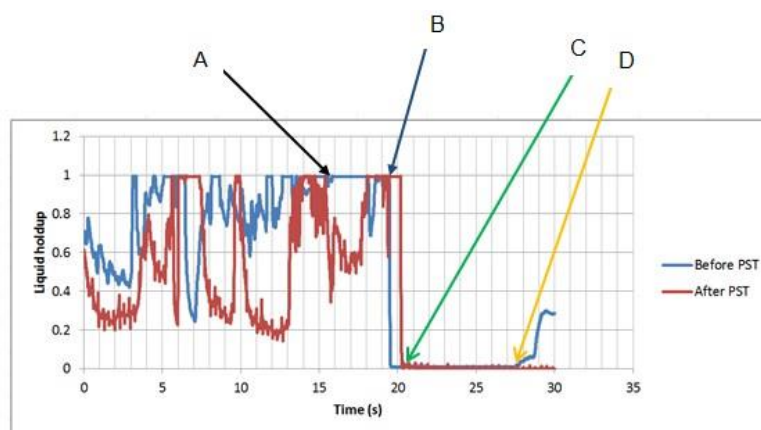

Fig. 10 Variation of liquid holdup with time at  $(V_{sl}, V_{sg}) = (0.37 \text{ m/s}, 0.39 \text{ m/s})$

The variation in the average pig velocity with the mixture velocity at a liquid velocity of 0.27 m/s and air superficial velocities of 0.94, 1.32 and 1.93 m/s, was studied and the result is as shown in Figure 11. Unlike in Figure 8, no clear-cut relationship could be established between the average pig velocity and mixture velocities. The average pig velocity increased from 0.98 m/s to 2.09 m/s as the mixture velocity increased from 1.21 to 1.59 m/s, and then dropped from 2.08 m/s to 0.44 m/s as the mixture

velocity increased from 1.59 to 2.2 m/s. This abnormal trend was a result of cases of stuck pigs inside the PST at low liquid velocities.

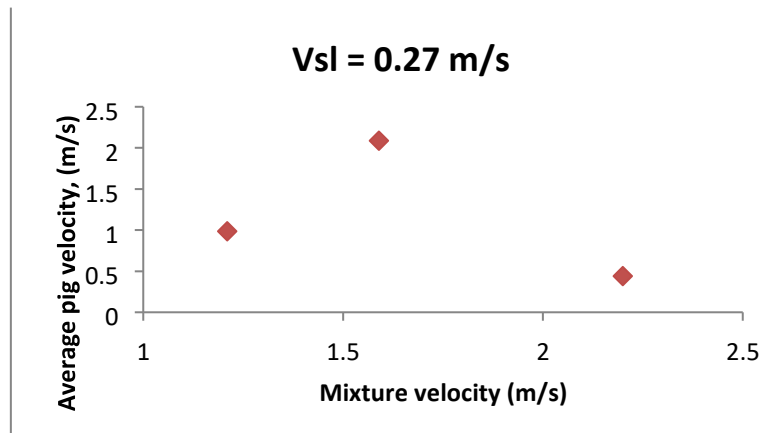

Figure 11: Variation of pig's average velocity with air-water velocity for  $V_{sl} 0.27$  m/s

However, at a higher liquid velocity of 0.8 m/s over a range of air superficial velocities, there is a clear, linear relationship between the pig's velocity and the air-water mixture velocity as seen in Figure 12. This observed positive correlation between the pig's velocity and the driving fluid velocity at this velocity follows the expected trend.

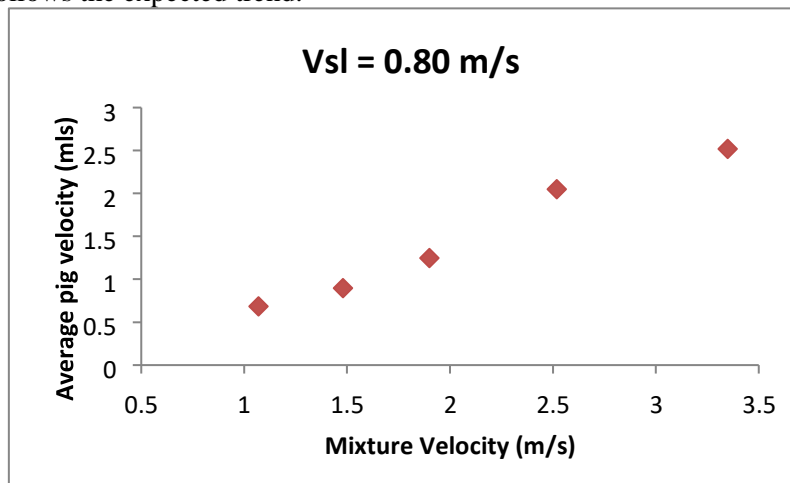

Fig. 12 Variation of pig's average velocity with air-water mixture velocity for  $V_{sl} 0.80$  m/s

From the results, it can be said that pigging operations show more success at high fluid velocity than at low fluid velocity. This suggests that at these flow conditions (usually very low liquid flow rates), a smooth pigging operation of the device cannot be achieved.

The observed positive correlation between the pig velocity and the driving fluid velocity for the single-phase pigging seems to follow common logic. However, this was not the case for various flow conditions investigated for the two-phase pigging, which was as a result of the occasional and temporal cases of stuck pigs inside the PST, which the oncoming fluid was able to drive out.

#### 4 Conclusion

The hydrodynamic slug attenuation potential of a passive slug attenuation device (PST) has been investigated. The device was observed to partially attenuate slug flow. However, the slugs were observed to redevelop downstream the device. It is therefore necessary to install the device at the

immediate upstream end of critical equipment such as first stage separator for effective slug attenuation.

The single-phase pigging operations were successful. However, at low flow rates, the pig was observed to get stuck in the PST. This scenario of stuck pigs was more pronounced during two-phase flow pigging at low liquid rates. Pigging the PST device may be easier for single phase flows relative to multiphase flows. If multiphase pigging must be done, high liquid velocities should be used. In both single-phase and two-phase (air-water) pigging operations, the average pig velocity was observed to be lesser than the liquid or mixture velocity of the driving fluid. The discrepancy was attributed to the resistances due to drag force and frictional forces of the pig on the transporting fluid and wall pipeline.

Foam pig was observed to perform better than other type of pigs investigated in this study. A further work on the efficiency of the use of flexible pigs for smooth pigging operation of the PST device is therefore proposed.

### Acknowledgement

The Authors thank Petroleum Technology Development Fund (PTDF) and Niger Delta Development Commission (NDDC), Nigeria, for wholly sponsoring the M.Sc programme of Ajibola Ogunbiyi and supporting the PhD programmes of Adegboyega Ehinmowo respectively.

### References

- [1] Schmidt, Z., Doty, D. & Dutta-Roy, K. (1985). Severe slugging in offshore pipeline riser-pipe systems. *Old SPE Journal*, 25 (1): 27–38.
- [2] Malekzadeh, R., Henkes, R. & Mudde, R.F., (2012). Severe slugging in a long pipeline–riser system: Experiments and predictions. *International Journal of Multiphase Flow*, 46, pp.9–21.
- [3] Zheng, G., Brill, J.P. & Taitel, Y. (1994). Slug flow behavior in a hilly terrain pipeline. *International Journal of Multiphase Flow*, 20 (1): 63–79.
- [4] Tengesdal, J.O., Thompson, L. & Sarica, C., A (2003). Design Approach for Self-Lifting” Method to Eliminate Severe Slugging in Offshore Productino Systems”. In *SPE Annual Technical Comferece and Exhibition*. Denver, Colorado, USA.
- [5] Sarica, C., Begen, P., Pereyra, E. and Kouba, G. (2014). Feasibility of surfactants as severe slugging suppression agents. In *9th North American Conference on Multiphase Technology*. Banff, Canada: BHR Group.
- [6] Bøe, A. (1981). Severe slugging characteristics; part i: flow regime for severe slugging; part ii: Point model simulation study. *Selected Topics in Two-Phase Flow, NTH, Trondheim, Norway*
- [7] Taitel, Y. (1986). Stability of severe slugging. *International Journal of Multiphase Flow*, 12 (2): 203–217.
- [8] Pots, B., Bromilow, I. & Konijn, M. (1987). Severe slug flow in offshore flowline/riser systems. *SPE Production Engineering*, 2 (4): 319–324.
- [9] Tin, V. (1991). Severe slugging in flexible risers. In *International Conference on multiphase production*. Cannes, France, BHRG, p. 507.
- [10] Tin, V. & Sarshar, M.M. (1993). An investigation of severe slugging characteristics in flexible risers. In *Proc. 6th Int. Conf. on Multiphase Production, BHRG, France*. p. 228.
- [11] Xing, L. (2011). *Passive slug mitigation by applying wavy pipes*. PhD Thesis. Cranfield University, Bedford, UK.
- [12] Ehinmowo, A.B. (2015). *Stabilising slug flow at large valve opening using an intermittent absorber*. PhD Thesis, Cranfield University, UK.
- [13] Pickering, P.F., Hewitt, G.F., Watson, M.J. and Hale C.P. (2001). The prediction of flows in production risers-truth & myth. In *Institute of International Research (IIR) Conference*. Aberdeen, UK, p. 1.
- [14] Issa, R.I. & Woodburn, P.J. (1998). Numerical prediction of instabilities and slug formation in horizontal two-phase flows. In *3rd International Conference on Multiphase Flow, ICMF98*. Lyon, France.
- [15] Issa, R.I. & Kempf, M.H.W. (2003). Simulation of slug flow in horizontal and nearly horizontal pipes with the two-fluid model. *International Journal of Multiphase Flow*, 29 (1): 69–95.
- [16] Danielson, T. (2011). A simple model for hydrodynamic slug flow. In *Offshore Technology Conference*. Houston, Texas, USA.

- [17] Issa, R.I., Barbeau, S., Hale, C.P., Odozi, U., Hewitt, G.F., Richardson, S.M. and Wong, W.L. (2007). Measurement and prediction of slug characteristics in three-phase flows. In *13th International Conference on Multiphase Production Technology*. Edinburgh, UK: BHR Group.
- [18] Brill, J., Zelimir, S., Coberly, W., Herring, J and Moore, D. (1981). Analysis of two-phase tests in largediameter flow lines in Prudhoe Bay field. *Old SPE Journal*, 21 (3): 363–378.
- [19] Guzman Vazquez, E. & Fairuzov, Y. (2009). A study of normal slug flow in an offshore production facility with a large diameter flowline. *SPE Production & Operations*, 24 (1): 171–179.
- [20] Danielson, T., Bansal K.M., Djoric, B., Larrey D., Johansen, S.T., De Leebeek, A. and Kjølås J. (2012). Simulation of Slug Flow in Oil and Gas Pipelines Using a New Transient Simulator. In *Offshore Technology Conference*. Houston, Texas, USA: SPE.
- [21] Ogazi, A., Cao, Y., Yeung, H. and Lao, L. (2010). Slug control with large valve openings to maximize oil production. *SPE Journal*, 15 (3): 812–821.
- [22] Xing, L., Yeung H., Shen J. and Cao, Y. (2013a). A new flow conditioner for mitigating severe slugging in pipeline/riser system. *International Journal of Multiphase Flow*, 51: 65–72.
- [23] Ehinmowo, A.B. & Cao, Y. (2015). Stabilizing slug flow at large valve opening using active feedback control. In *Proceedings of the 21st International Conference on Automation & Computing*. University of Strathclyde, Glasgow, UK.
- [24] Storkaas, E. & Skogestad, S. (2003). Cascade control of unstable systems with application to stabilization of slug flow. In *International Symposium on Advanced Control of Chemical Processes AdChem '03*. Hong Kong.
- [25] Jahanshahi, E. & Skogestad, S. (2011). Simplified dynamical models for control of severe slugging in multiphase risers. In *18th IFAC World Congress*, Milano, Italy, pp. 1634–1639.
- [26] Yocum, B.T. (1973). Offshore riser slug flow avoidance: mathematical models for design and optimization. In *SPE European Meeting*. London, England.
- [27] Miyoshi, M., Doty, D. R. and Schmidt, Z. (1988) 'Slug-catcher design for dynamic slugging in an offshore production facility', *SPE production engineering*. Society of Petroleum Engineers, 3(4), pp. 563–573.
- [28] Xing, L., Yeung H., Shen J. and Cao, Y. (2013b). Experimental study on severe slugging mitigation by applying wavy pipes. *Chemical Engineering Research and Design*, 91 (1): 18–28.
- [29] Makogan, T. and Brook, G. (2007) 'Device for controlling slugging', *Device for controlling slugging*. USA: WO Patent 2,007,034,142.
- [30] Makogon, T., Estanga, D. and Sarica, C. (2011) 'A new passive technique for severe slugging attenuation', in *15th International Conference on Multiphase Production Technology*. Cannes, France: BHR Group.
- [31] Adedigba, A.G., Badr, O., Yeung H., Waring, R. and Caro, C. (2006). The use of novel pipe device to reduce severe slugging in pipeline-riser systems. In *5th North American Conference on Multiphase Technology*. Banff, Canada: BHR Group.
- [32] Brasjen, B. J. *et al.* (2013) 'Experimental investigation of terrain slugging formation, evolution and potential for mitigation', in *16th International Conference on Multiphase Production Technology*. Cannes, France: BHR Group.
- [33] Adedigba, A. G. (2007) *Two-phase flow of gas-liquid mixtures in horizontal helical pipes*. PhD Thesis. Cranfield University, Bedford, United Kingdom
- [34] Almeida, A. R. and Goncalves A.L., M. (1999) 'Venturi for severe slug elimination', in *BHR Group Conference Series Publication*. Bury St. Edmunds; Professional Engineering Publishing; 1999, pp. 149–160.
- [35] Sarica, C. and Tengedal, J. Ø. (2000) 'A new technique to eliminate severe slugging in pipeline/riser systems', in *SPE Annual Technical Conference and Exhibition*. Dallas, Texas, USA.
- [36] Tengedal, J. Ø. (2002) *Investigation of self-lifting concept for severe slugging elimination in deepwater pipeline/riser systems*. Pennsylvania State University.
- [37] Schrama, E. and Fernandes, R. (2005) 'The bubble breaker: Breaking up slug flow into dispersed bubbly flow using a passive mechanical device', in *12th International Conference on Multiphase Production Technology*. Barcelona, Spain: BHR Group.
- [38] Ehinmowo, A.B., Aliyu, A.M., Alagbe, S.O., Adedipe O. and Olumi O. (2015). Offshore Topside Rotating Packed Bed as Process Intensified Alternative for Natural Gas Sweetening and Dehydration. *American Chemical Science Journal*, 8 (4): 1–12.
- [39] Rocha, A.D., Bannwart, A.C. & Ganzarolli, M.M. (2015). Numerical and experimental study of an axially induced swirling pipe flow. *International Journal of Heat and Fluid Flow*, 53, pp.81–90.

- [40] Najafi, A. F., Mousavian, S. M. and Amini, K. (2011) 'Numerical investigations on swirl intensity decay rate for turbulent swirling flow in a fixed pipe', *International Journal of Mechanical Sciences*, 53(10), pp. 801–811. doi: 10.1016/j.ijmecsci.2011.06.011.
- [41] Yeung, H. & Cao, Y. (2007). *Effects of Geometry at the Riser Base on Riser Hydrodynamic Behaviour*, Bedford, UK.
- [42] Tiratsoo, J.N.H. (1991). *Pipeline pigging and integrity technology* 2nd editio., Beaconsfield.
- [43] Cordell, J and Vanzant, H. (2003). *The pipeline pigging handbook* 3rd ed., Houston Texas, USA: Clarion Technical Publishers.
- [44] Nwoke, O. N., Okokpujie, I. P., & Ekenyem, S. C. (2017). Investigation of Creep Responses of Selected Engineering Materials. *Journal of Science, Engineering Development, Environmen and Technology (JOSEDET)*, 7(1), 1-15.
- [45] Ogunbiyi, A.T. (2012). *Pigging of a passive slug mitigation device*. MSc Thesis, Cranfield University, UK.
- [46] Mandhane, J.M., Gregory, G.A. & Aziz, K., 1974. A flow pattern map for gas—liquid flow in horizontal pipes. *International Journal of Multiphase Flow*, 1 (4): 537–553.