

# Knockout mouse model for *Fxr2*: a model for mental retardation

Carola J. M. Bontekoe<sup>1</sup>, Kellie L. McIlwain<sup>2</sup>, Ingeborg M. Nieuwenhuizen<sup>1</sup>,  
Lisa A. Yuva-Paylor<sup>2</sup>, Anna Nellis<sup>2</sup>, Rob Willemsen, Zhe Fang<sup>2</sup>, Laura Kirkpatrick<sup>2</sup>,  
Cathy E. Bakker<sup>1</sup>, Robin McAninch<sup>2</sup>, Ngan Ching Cheng<sup>1</sup>, Michelle Merriweather<sup>2</sup>,  
Andre T. Hoogeveen<sup>1</sup>, David Nelson<sup>2</sup>, Richard Paylor<sup>2,3</sup> and Ben A. Oostra<sup>1,\*</sup>

<sup>1</sup>CBG Department of Clinical Genetics, Erasmus University, Rotterdam, The Netherlands, <sup>2</sup>Department of Molecular and Human Genetics and <sup>3</sup>Division of Neuroscience, Baylor College of Medicine, Houston, TX, USA

Received September 29, 2001; Revised and Accepted January 7, 2001

Fragile X syndrome is a common form of mental retardation caused by the absence of the FMR1 protein, FMRP. *Fmr1* knockout mice exhibit a phenotype with some similarities to humans, such as macro-orchidism and behavioral abnormalities. Two homologs of FMRP have been identified, FXR1P and FXR2P. These proteins show high sequence similarity, including all functional domains identified in FMRP, such as RNA binding domains. They have an overlap in tissue distribution to that of FMRP. Interactions between the three FXR proteins have also been described. FXR2P shows high expression in brain and testis, like FMRP. To study the function of FXR2P, we generated an *Fxr2* knockout mouse model. No pathological differences between knockout and wild-type mice were found in brain or testis. Given the behavioral phenotype in fragile X patients and the phenotype previously reported for the *Fmr1* knockout mouse, we performed a thorough evaluation of the *Fxr2* knockout phenotype using a behavioral test battery. *Fxr2* knockout mice were hyperactive (i.e. traveled a greater distance, spent more time moving and moved faster) in the open-field test, impaired on the rotarod test, had reduced levels of prepulse inhibition, displayed less contextual conditioned fear, impaired at locating the hidden platform in the Morris water task and were less sensitive to a heat stimulus. Interestingly, there are some behavioral phenotypes in *Fxr2* knockout mice which are similar to those observed in *Fmr1* knockout mice, but there are also some different behavioral abnormalities that are only observed in the *Fxr2* mutant mice. The findings implicate a role for *Fxr2* in central nervous system function.

## INTRODUCTION

Fragile X syndrome is the most common form of inherited mental retardation affecting 1 in 4000 males (1,2). The main characteristics of the syndrome are mental retardation and macro-orchidism in males (3). This disorder is a result of an expanded CGG trinucleotide repeat in the 5'-untranslated region (5'-UTR) of the FMR1 gene (4–6). This X-linked disorder is caused by the absence of the fragile X mental retardation 1 protein (FMRP). Since the cloning of *FMR1* in 1991 much effort has been put into unraveling the function of FMRP (5,7–9). Although the precise function of FMRP has not been elucidated several characteristics of the protein have been described. Two homologs of *FMR1*, *FXR1* and *FXR2*, have been identified (10–12). Together, the three proteins form a small family of fragile X related (FXR) proteins. Since these proteins show a high sequence homology, and overlap in tissue distribution, analogous functions are suggested (13,14). It has

been suggested that these proteins might partly complement one another. Therefore, to unravel the function of these proteins and to understand how the absence of FMRP causes the fragile X phenotype the studies concerning FMRP are extended to study the three proteins and their possible interactions. FMRP contains conserved sequence motifs, two KH domains and an RGG box (15) which are present in many RNA binding proteins. FMRP has also been found to be associated with ribosomes (16,17) and to be present in neuronal dendrites (8,14). The RNA binding domains appear to be functional, since *in vitro* binding of FMRP to homopolymeric RNA was shown, and FMRP showed a selectivity for a fraction of mRNAs expressed in brain including its own mRNA (7,18,19). FMRP is mainly cytoplasmic, but the presence of a nuclear export signal (NES) as well as a nuclear localization signal (NLS) suggest that FMRP is capable of shuttling between the nucleus and the cytoplasm (17,20,21).

\*To whom correspondence should be addressed at: Department of Clinical Genetics, Erasmus University, PO Box 1738, 3000DR Rotterdam, The Netherlands. Tel: +31 10 4087198; Fax: +31 10 4089489; Email: oostra@kgen.fgg.eur.nl

The authors wish it to be known that, in their opinion, the first two authors should be regarded as joint First Authors

Present address:

Kellie L. McIlwain, Primal Inc., Seattle, WA, USA

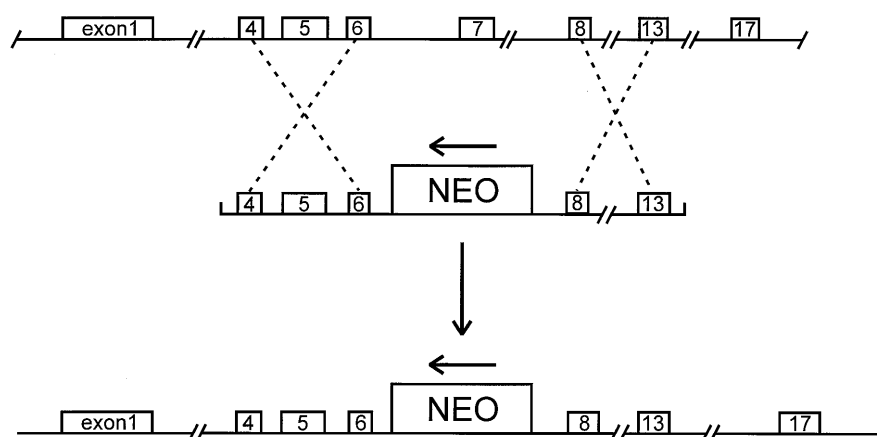

**Figure 1.** Targeting construct disrupting *Fxr2* by removing exon 7. An antisense *neo* cassette was cloned to allow selection of the transfected ES cells.

The three FXR proteins are very homologous by amino acid sequence, especially throughout the N-terminal and central regions (for FXR1P and FXR2P, 86 and 70% identity, respectively). Consistent with this homology, the functional domains characterized in FMRP are also found in FXR1P and FXR2P. Both FXR1P and FXR2P contain an NES and an NLS (17). Recently, nucleolar-targeting signal has been identified for both FXR1P and FXR2P (22). The C-termini of the three proteins are, however, highly divergent, sharing only 6% similarity.

The pattern of tissue distribution is also similar between FMRP, FXR1 and FXR2. Like FMRP, both FXR1P and FXR2P are expressed in the organs affected by fragile X syndrome. In brain FMRP, FXR1P and FXR2P are found in the cytoplasm of neurons. A minority FXR1P was demonstrated in the nucleolus of some neurons. However, in testis FMRP is expressed in early spermatogonia, together with FXR1P and FXR2P. In contrast to FMRP, there is also high expression of FXR1P and FXR2P in the more maturing spermatogenic cells (23,24).

The similarities found between the three proteins at the amino acid level, the overlap in tissue distribution, and the fact that the proteins can interact led to the suggestion that the FXR proteins have analogous functions. Since the relatively mild phenotype observed in fragile X patients is difficult to reconcile with the fundamental properties of FMRP, it has been suggested that the *Fxr1* and *Fxr2* genes are capable of complementing (partially) the functions of FMRP functions, which might explain the relatively mild phenotype observed in fragile X patients.

Like FMRP, FXR1P and FXR2P are conserved in other species. All three proteins are also found in mice. A knockout mouse for *Fmr1* was generated in order to study the function of Fmrp (25). The phenotype of the *Fmr1* knockout mice shows some similarities to the phenotype observed in fragile X patients. The *Fmr1* knockout mice are hyperactive (25,26), have abnormal anxiety-related responses (26), and have impaired motor coordination (26). Although not observed by all investigators, e.g. Peier *et al.* (26), *Fmr1* knockout mice display mild learning impairments on some learning and

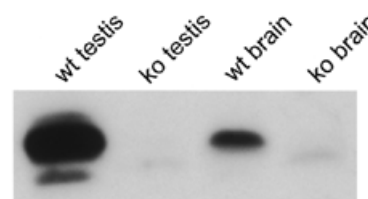

**Figure 2.** Western blot analysis indicates that the *Fxr2* knockout mice do not express Fxr2p.

memory tasks (25,27–30). Interestingly, learning performance appears to depend on genetic background (28,29). Finally, *Fmr1* knockout mice show macro-orchidism. Knockouts for *Fxr1* proved to be lethal (H.Siomi, personal communication). Homozygous *Fxr1* knockout mice were born alive, but died within a few hours. Most likely, these mice die because of failure of the respiratory system. Fxr1p is highly expressed in muscle and the lack of Fxr1p could influence the function of the lungs and the heart, which are composed of predominantly muscle tissue.

Here we describe the generation of a knockout mouse for *Fxr2*. Fxr2p is also relatively highly expressed in brain and testis. If the FXR proteins indeed have analogous functions our *Fxr2* knockout mouse model might shed more light on the function of the FXR proteins and how these proteins interact or influence each other. Double knockouts of *Fmr1* and *Fxr2* might provide data about the likelihood that Fxr2p can compensate partly for the absence of Fmrp.

## RESULTS

After ES cell electroporation using plasmid pCB33 (Fig. 1) 700 colonies were picked and three homologous recombinant clones were identified by PCR and Southern blot analysis. Two clones were used for blastocyst injection. Germline chimeras were obtained. F1 heterozygous littermates were crossed to homozygosity in order to generate *Fxr2* knockout mice.

Mice homozygous for the null allele developed normally and no macroscopic differences could be identified. The mice

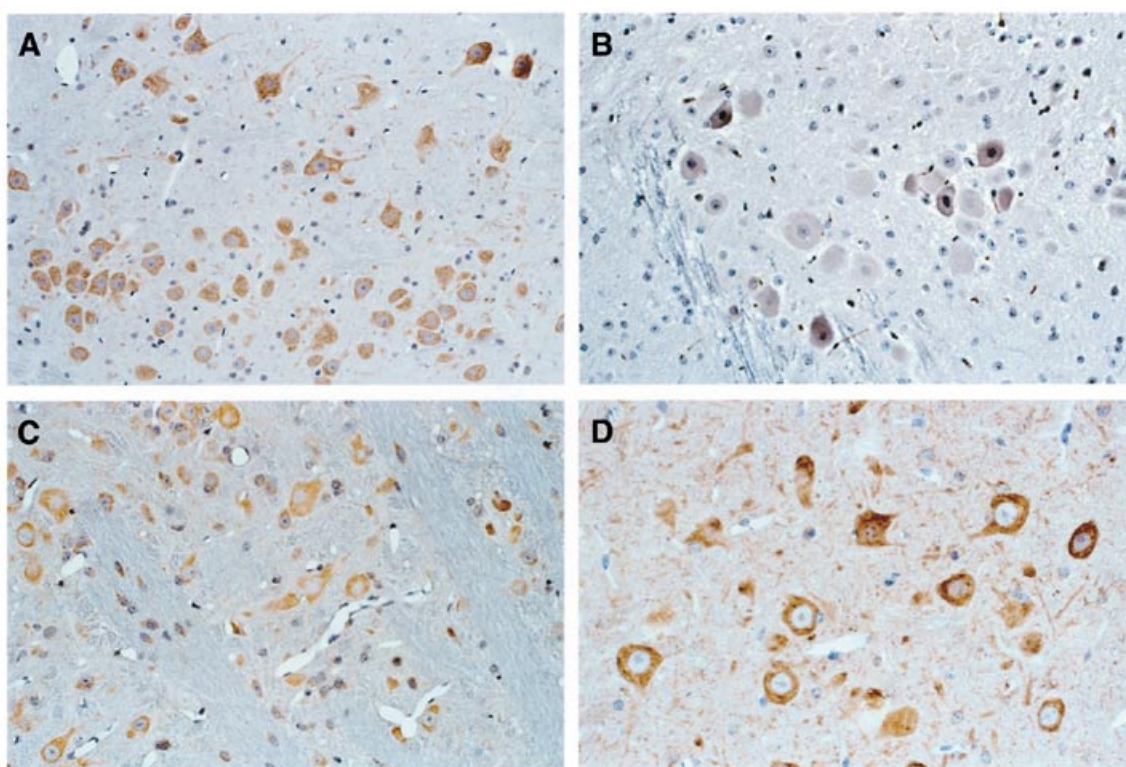

**Figure 3.** Fxr2p expression in brainstem of wild-type (A) and *Fxr2* knockout mice (B). The expression of Fmrp (D) and Fxr1p (C) in *Fxr2* knockout mice was not changed compared to wild-type (data not shown).

appear viable and fertile. As *Fmr1* KO mice showed enlarged testicles the testis weight of *Fxr2* mice was determined. The *Fxr2* null mice did not show enlarged testicles (data not shown).

### Immunohistochemistry

To test whether the mice homozygous for the mutated *Fxr2* gene were indeed knockout for Fxr2 protein (Fxr2p), western blotting and immunohistochemistry were performed using standard procedures. For western blotting two antibodies were used, monoclonal A42 and polyclonal 1937, for immunohistochemistry only polyclonal 1937 was used. Western blotting (Fig. 2) as well as immunohistochemistry (Fig. 3B) confirmed that knockout mice were indeed negative for Fxr2p.

Light microscopic examination, using routine staining techniques showed no gross abnormalities when comparing *Fxr2* knockout mice with wild-type littermates (data not shown). Immunocytochemical analysis of sagittal brain sections (wild-type and *Fxr2* KO mice), using antibodies against specific brain markers, including SMI31, MAP-2, TAU protein and synaptophysin revealed no pathological abnormalities in the brain compared to wild-type brain sections (Fig. 4). In addition, we showed the absence of Fxr2p in brain tissue (neurons) from *Fxr2* knockout mice, using monospecific antibodies against FXR2P (Fig. 3). In contrast, sections of brain tissue from wild-type mice showed the presence of Fxr2p in the cytoplasm of neurons. Interestingly, the expression pattern of Fmrp and Fxr1p in neurons of *Fxr2* knockout mice is similar to the expression in neurons of wild-type mice (Fig. 3C and D).

### Behavioral tests

*Fxr2* knockout male mice and wild-type littermates were subjected to a battery of behavioral assays, which included tests for simple sensory and motor function, locomotor activity, anxiety-related responses, motor coordination and skill learning, sensorimotor gating, sensory adaptation, conditioned fear, spatial learning and analgesic-related responses. These tests were performed to characterize a range of domains of CNS function, and to compare them to the recent behavioral results (26) of the *Fmr1* knockout mice.

To ensure that there were no severe neurological abnormalities which would potentially interfere with subsequent testing, mice in batch A were evaluated on a neurological screen (31). There were no differences in the baseline responses between *Fxr2* KO and wild-type mice in this simple neurological screen assessment suggesting that they had no gross, overt behavioral anomalies.

For each of the tests discussed below the overall main effect of genotype is presented. However, only the batch effects that were statistically significant are reported below. Finally, there were no significant genotype X batch interactions ( $P > 0.3$ ), therefore the interaction terms are not presented.

### Locomotor activity in the open-field.

The open-field test is used to assess locomotor activity and anxiety-related responses. One wild-type had to be excluded from the analysis due to experimental error. *Fxr2* knockout mice were significantly more active in the open-field



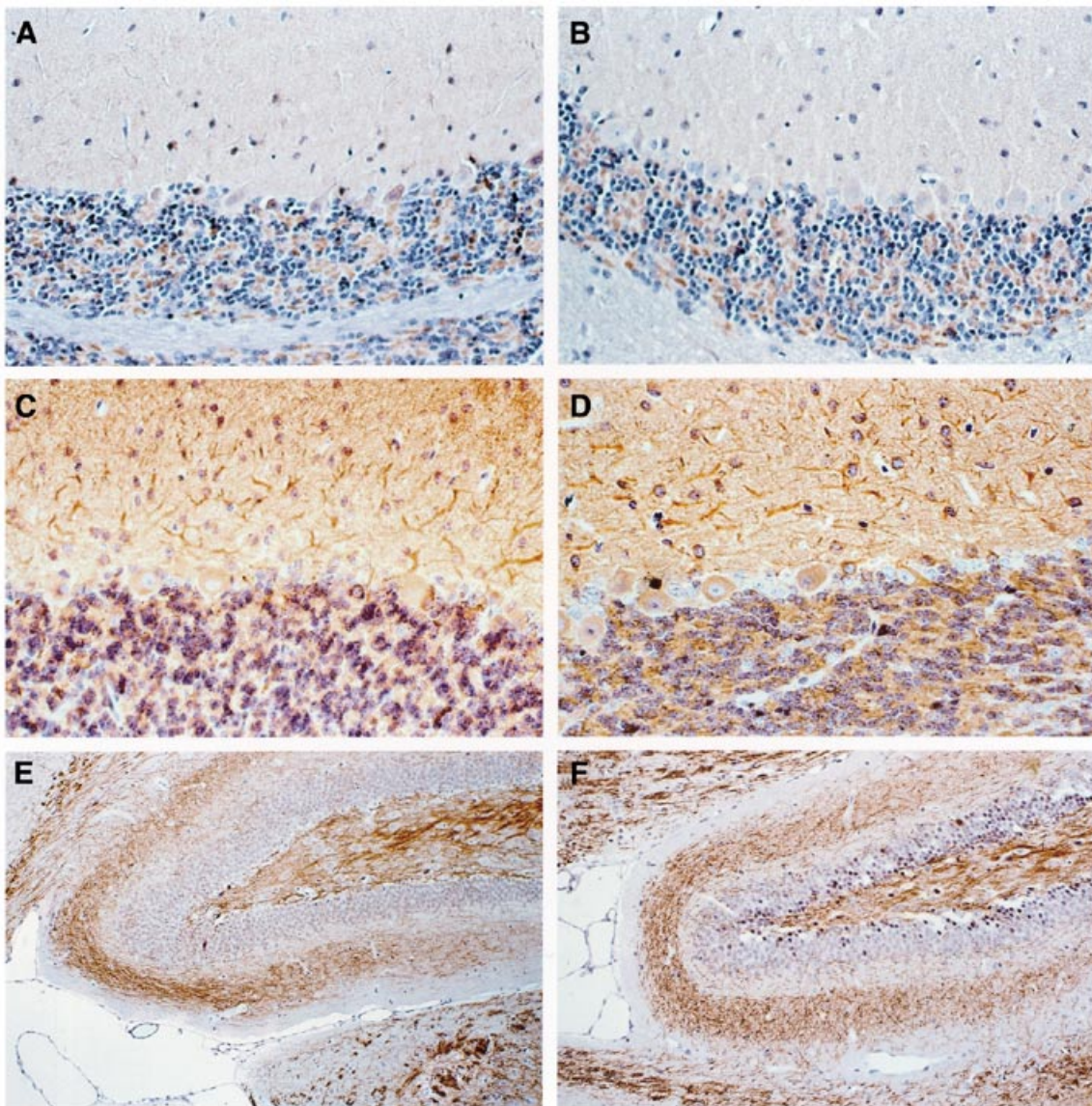

**Figure 4.** Immunohistochemical analysis of brain sections [(A–D) cerebellum; (E and F) hippocampus] using the markers synaptophysin (A and B), MAP-2 (C and D) and SMI 31 (E and F) did not show differences between wild-type (A, C, E) and *Fxr2* knockout mice (B, D, F).

compared to the wild-type mice. *Fxr2* knockout mice traveled a greater distance [ $F(1,52) = 22.67$ ,  $P = 0.00002$ ] (Fig. 5A), spent more time moving [ $F(1,52) = 22.18$ ,  $P = 0.00002$ ] (Fig. 5B) and traveled faster [ $F(1,52) = 7.6378$ ,  $P = 0.007$ ] (data not shown). *Fxr2* mutant mice did not rear more often than wild-type mice [ $F(1,52) = 0.816$ ,  $P = 0.37$ ] (data not shown). Together these results show that the *Fxr2* knockout show characteristics of hyperactivity compared to wild-type littermates.

The open-field test one can also assess anxiety-related response using a center:total distance ratio. Mice prefer to explore the perimeter of the open-field and tend to avoid the center of the arena. The avoidance of the center of the open-field, therefore, is believed to reflect an animal's level of anxiety-related responses. There were no differences in the levels of anxiety-related responses between *Fxr2* knockout and wild-type mice as measured using this center:total distance ratio from the open-field test [ $F(1,52) = 0.00003$ ,  $P = 0.996$

(Fig. 5C). Consistent with this finding is the fact that there were also no differences between *Fxr2* knockout and wild-type mice on the light–dark test, another assay for anxiety-related responses (data not shown).

#### Rotarod test

The rotarod test is used to study motor coordination and skill learning. Figure 6 shows that the *Fxr2* knockout mice performed significantly worse than their wild-type littermates [ $F(1,53) = 7.725$ ,  $P = 0.007$ ]. An important aspect of this data is the fact that the performance of both the *Fxr2* mutants and wild-types improved significantly during training [ $F(7,371) = 57.629$ ,  $P < 0.00001$ ], and that there was no genotype X trial interaction [ $F(1,53) = 1.634$ ,  $P = 0.206$ ]. In addition, a comparison of the performance curves using linear and quadratic trend analyses showed that both genotypes have significant linear

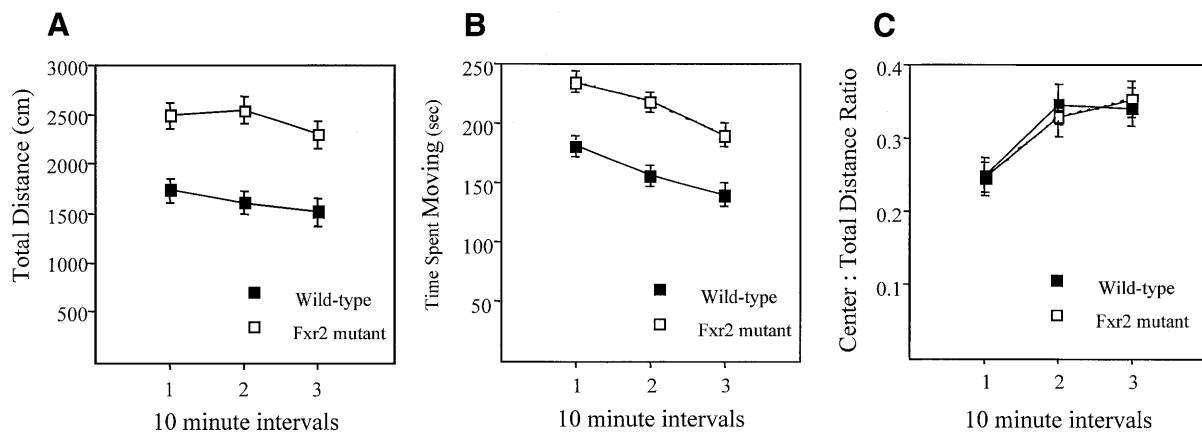

**Figure 5.** Mice were tested in an open-field arena for 30 min. *Fxr2* mutant mice are more active in the open-field test as assessed by (A) the total distance traveled (in cm) and (B) the time spent moving. (C) *Fxr2* KO and wild-type mice have similar levels of anxiety-related responses as measured using the center:total distance ratio. The mean ( $\pm$ SEM) data over three 10 min intervals are presented.

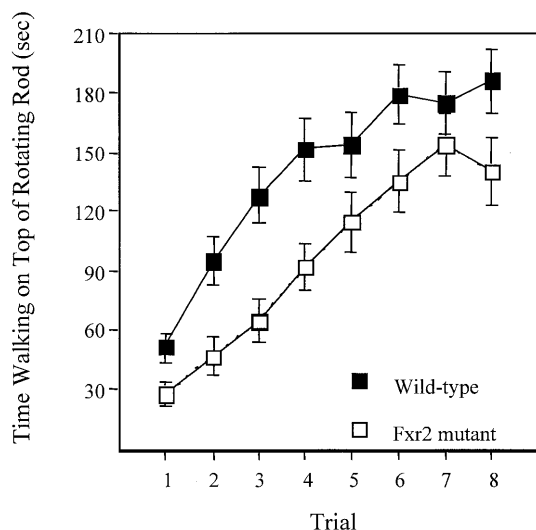

**Figure 6.** Motor coordination and skill learning was tested using the rotarod assay. *Fxr2* KO mice spent less time walking on top of the rotating rod compared to their wild-type littermates. The means ( $\pm$ SEM) are presented.

and quadratic trends ( $P < 0.00$ ). Thus, the rate for the improved performance was similar for both *Fxr2* mutant and wild-type mice. Therefore, this pattern of data suggest that the overall impaired rotarod performance in *Fxr2* mutants is related to impaired motor coordination, not skill learning.

#### Acoustic startle and prepulse inhibition of the acoustic startle response

Prepulse inhibition is used to assay sensorimotor gating by quantitating the normal suppression of a startle that is preceded by a weak, non-startling prestimulus. The maximum startle amplitude and prepulse inhibition data are presented in Figure 7. In all of our studies we eliminate mice that do not show a startle response because it is not possible to evaluate prepulse inhibition in an animal that does not startle. In this study three mice did not show the minimum startle response (two wild-type and one mutant) and their data were not included in the

overall analyses. There was no significant difference in the acoustic startle response between *Fxr2* knockout and wild-type mice [ $F(1,49) = 0.365$ ,  $P = 0.0548$ ] (Fig. 7A). Overall, the level of prepulse inhibition increased as the sound level of the prepulse increased for both wild-type and *Fxr2*-deficient mice [ $F(4,196) = 217.19$ ,  $P < 0.00001$ ] (Fig. 7B). However, the overall levels of prepulse inhibition were significantly lower in *Fxr2* knockout mice compared to the wild type littermates [ $F(1,49) = 4.595$ ,  $P = 0.037$ ]. These findings suggest that the basic startle response is normal in *Fxr2* mutants, but sensorimotor gating as assessed using the prepulse inhibition paradigm is impaired.

#### Acoustic startle habituation

Consistent with the startle response data acquired during the prepulse inhibition test, there was no significant difference in the overall startle response between the *Fxr2* knockout and wild-type mice during the startle habituation test [ $F(1,49) = 0.103$ ,  $P = 0.748$ ] (data not shown). Importantly, both genotypes did show a significant decrease (i.e. habituated) to the startle response across the 100 startle presentations [ $F(9,441) = 14.168$ ,  $P < 0.00001$ ]. There was a significant batch effect [ $F(1,49) = 8.107$ ,  $P = 0.006$ ], which resulted from the overall levels of startle in the first batch being lower than the responses of the second batch.

#### Conditioned fear

The conditioned fear test is utilized to assay a fear-based response using a Pavlovian learning and memory paradigm. Levels of freezing for the context and auditory cued conditioned fear tests are shown in Figure 8. Two mice (one of each genotype) had to be excluded because they did not respond to the foot-shock during training. During the context test, *Fxr2* knockout mice displayed significantly less freezing responses than their wild-type littermates [ $F(1,50) = 6.078$ ,  $P = 0.017$ ]. In contrast, the *Fxr2* knockout mice showed similar levels of freezing during the conditioned stimulus (CS) test [ $F(1,50) = 0.329$ ,  $P = 0.568$ ]. These findings suggest that *Fxr2* knockout mice have a selective impairment in fear conditioning that is associated

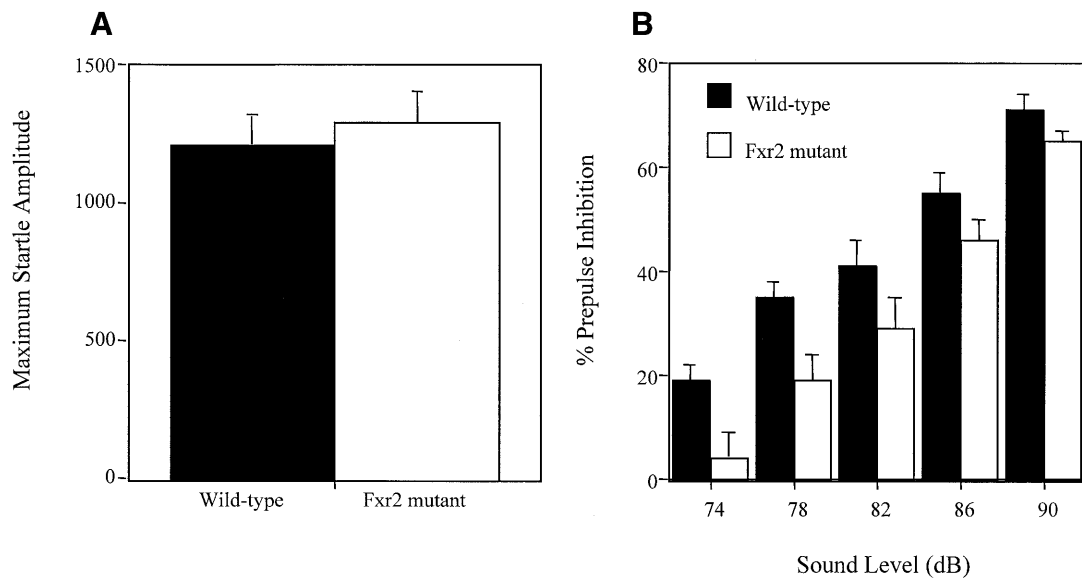

**Figure 7.** Sensorimotor gating was measured using the prepulse inhibition of the acoustic startle paradigm. (A) The maximum startle amplitude to a 120 dB sound burst (40 ms) was similar in *Fxr2* KO and wild-type mice. (B) Sensorimotor gating was reduced in *Fxr2* KO mice as shown by the significantly lower levels of PPI compared to wild-type mice. The means ( $\pm$ SEM) are presented.

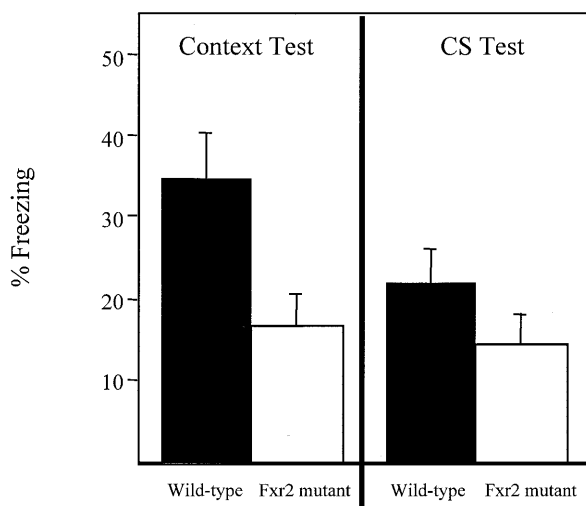

**Figure 8.** Percentage freezing in the conditioned fear test. *Fxr2* KO mice displayed significantly less freezing responses during the context test, but showed similar levels of freezing during the CS test. The means ( $\pm$ SEM) are presented.

with the context or environment where the shock occurred, but not to a single cue that is associated with the foot-shock.

### Morris water maze

The hidden-platform version of the Morris water task is widely accepted for examining spatial learning and memory in mice. During Morris water-task training some mice will float or jump off the platform. Since these responses may be incompatible with the behaviors needed to locate and learn the platform's position, we routinely eliminate mice from the experiment if they float or jump from the platform. Therefore, we had to

eliminate three mice (one knockout and two wild-type) from this experiment. In addition, one mutant mouse died due to unexplained reasons prior to the Morris testing.

The swim distance to the escape platform was significantly greater [ $F(1,48) = 9.244, P = 0.003$ ] and the time to locate the platform (data not shown) was significantly longer [ $F(1,48) = 16.33, P = 0.002$ ] in the *Fxr2* knockout mice compared to the wild-type controls (Fig. 9A). However, there was no overall difference [ $F(1,48) = 0.815, P = 0.37$ ] in swim speed (data not shown) between *Fxr2* knockout and wild-type mice.

During the probe trial wild-type mice displayed a normal spatially biased search pattern. The wild-type mice spent significantly more time in the training quadrant compared to the other quadrants [ $F(3,69) = 21.04, P < 0.00001$ ; spent more time in the training quadrant compared to other quadrants,  $P < 0.0001$ ] (data not shown) and they crossed the exact place where the platform had been located during training more often than equivalent locations in the other quadrants [ $F(3,69) = 9.4, P = 0.00003$ ; spent more time in training quadrant compared to other quadrants,  $P < 0.0003$ ] (Fig. 9B). Similarly, the *Fxr2* knockout mice spent significantly more time in the training quadrant compared to the other quadrants [ $F(3,81) = 6.49, P = 0.005$ ; time spent in the training quadrant was greater than the time in the quadrants to the left and opposite,  $P < 0.0003$ , time spent in the training quadrant was greater than the time spent in the quadrant to the right,  $P = 0.053$ ] (data not shown), and crossed the training site more often than the comparable site in the other quadrants [ $F(3,81) = 6.91, P = 0.0003$ ; time in the training quadrant was more than time spent in other quadrants,  $P < 0.006$ ] (Fig. 9B). The wild-type mice did spend significantly more time in the training quadrant compared to the time that the *Fxr2* mutants spent in the training site [ $F(1,48) = 9.9067, P = 0.004$ ], but the number of times the two genotypes crossed the training site was equivalent [ $F(1,48) = 2.147, P = 0.149$ ].

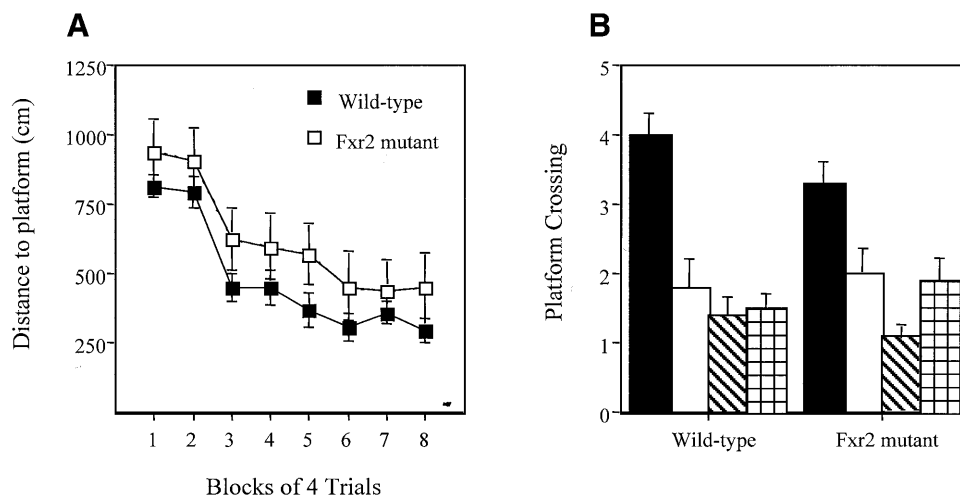

**Figure 9.** Spatial learning performance in the Morris water maze task. (A) *Fxr2* KO mice took significantly longer paths to locate the hidden platform during training. (B) Both wild-type and *Fxr2* KO mice showed spatially biased selective search patterns during the subsequent probe test. Both wild-type and *Fxr2* KO mice crossed the training site significantly more often than equivalent locations in the other quadrants. The means ( $\pm$ SEM) are presented.

Taken together, it appears that the *Fxr2* mutant mice are not as proficient at locating the platform as wild-type mice, but they do use a spatially biased search strategy. Comparing the quadrant search time data from the training quadrant only during the probe trial it appears that the wild-type mice may have a stronger spatial bias for the training site compared to the *Fxr2* KO mice. However, this difference is not supported by the platform crossing data, which is often considered a better indicator for spatial search accuracy. Thus, *Fxr2* KO mice do show spatial search behavior in the Morris water task.

### Hotplate

The time to the first hind-limb response is shown in Figure 10. The *Fxr2* knockout mice took significantly longer to shake or lick their hind-paw in response to the heat stimulus [ $F(1,51) = 9.86$ ,  $P = 0.0028$ ]. These findings suggest that the *Fxr2* knockout mice are less sensitive to this type of painful stimuli.

### DISCUSSION

Based on the sequence homology and partly overlapping tissue distribution, it has been hypothesized that FXR1P and FXR2P have functions analogous to those of FMRP. Furthermore, it was suggested and demonstrated in *in vitro* studies that the three homologs can interact with each other as homomers and heteromers. The physiological relevance of these interactions is not known. The absence of FMRP is known to cause the fragile X syndrome phenotype. Although FXR1P and FXR2P are not altered in fragile X syndrome patients, it is possible that FXR1P and/or FXR2P can compensate in part for the function of FMRP. In order to unravel the function of the FXR proteins and to study their possible interactions it is useful to study the three proteins together. The knockout mouse model for the fragile X syndrome proved to be highly valuable to study the function of FMRP (25,26). In order to extend these studies to the whole FXR family knockout mouse models will be generated for FXR1P and FXR2P. Here we describe the generation of a knockout mouse for *Fxr2*.

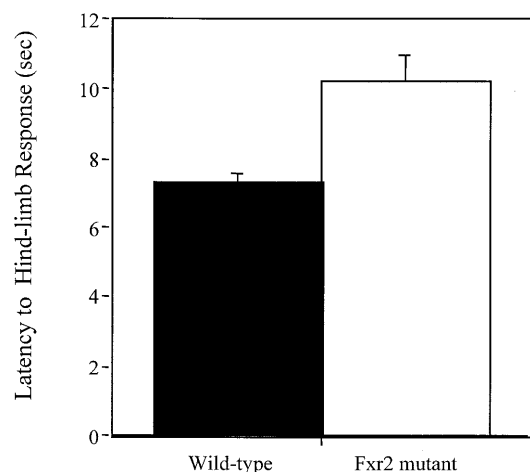

**Figure 10.** *Fxr2* KO mice took significantly longer to display a hind-limb response in the hotplate test for analgesia-related response. The means ( $\pm$ SEM) are presented.

The *Fxr2* knockout mice appear viable and fertile. Macroscopically no gross abnormalities were found. The expression of *Fxr2p* is relatively high in brain and testis; therefore special attention was paid to these organs. In brain, SMI, MAP-2 and synaptophysin were used as markers, but no differences in the organization of the brain was observed. Also in testis, based on immunohistochemistry, no differences were observed between *Fxr2* knockout and wild-type mice.

Responses on the behavioral test battery revealed several differences between *Fxr2* knockout and wild-type mice. *Fxr2* knockout mice were hyperactive (i.e. traveled a greater distance, spent more time moving and moved faster) in the open-field test, impaired on the rotarod test, had reduced levels of prepulse inhibition, displayed less contextual conditioned fear, were impaired at locating the hidden platform in the Morris water task and were less sensitive to a heat stimulus. In contrast, anxiety-related responses, acoustic startle, startle

**Table 1.** Comparison between *Fmr1* and *Fxr2* KO mice in behavioural studies

	Fxr2	Fmr1
Open Field	↑	↑
Anxiety-related	—	↓
Rotorod	↓	↓
PPI	↓	↑
Acoustic Startle	↑	—
Conditioned Fear	↓	—
Morris Water Maze	↓	—
Hot Plate	↓	—

habituation and auditory-cued conditioned fear were similar between the *Fxr2* knockout and wild-type mice. In addition, although the *Fxr2* knockout mice were less proficient at locating the hidden platform during training in the Morris water task, they did appear to be using a spatially-biased search strategy similar to the wild-type controls. These behavioral findings support a role for *Fxr2* in domains of CNS function that regulate behavioral responses.

There are several possible explanations for the impaired fear conditioning of the *Fxr2* knockout mice on the context test. Firstly, *Fxr2* knockout mice might be too hyperactive to show a normal freezing response. Secondly, *Fxr2* knockout mice may have reduced sensitivity to painful stimuli. Thirdly, *Fxr2* mice have a generalized impairment in learning and memory processes. Finally, the *Fxr2* mutant mice may have a selective learning and memory impairment that is related to a dysfunction in the process(es) related to the encoding, storing and/or retrieval of the multiple stimuli that make up the context test. Findings from the other behavioral tests provide some support for both the 'activity' hypothesis (i.e. *Fxr2* knockout mice are more active in the open-field) and the 'pain sensitivity' hypothesis (i.e. *Fxr2* mice have a decreased response on the hotplate test). However, the data from the CS test phase of the conditioned fear task best support the last 'selective context processing' hypothesis. *Fxr2* knockout mice display normal fear conditioning on the CS test, which indicates that they were not too hyperactive to show normal freezing during this phase of the test, and that they detected the shock well enough to learn that the auditory cue signaled shock. Although more experiments will need to be performed to understand more fully the nature of the context fear impairment, taken together the present data may best support the notion that *Fxr2* knockout mice have difficulty processing the type of information that is required for normal contextual fear conditioning.

Some, but not all, of the behavioral phenotypes of the *Fxr2* knockout mice resemble the phenotypes of the *Fmr1* knockout mice that were previously evaluated on the same behavioral test battery in the same laboratory (Table 1; 26). Both *Fxr2* and *Fmr1* knockout mice are hyperactive in the open-field test, and impaired on the rotarod test. In contrast, *Fmr1* knockout mice, but not *Fxr2* knockout mice, display less anxiety-related responses in the open-field and light-dark test. In addition, the

*Fmr1* knockout mice, but not *Fxr2* knockout mice, have a reduced acoustic startle response. From Table 1 one can also see that *Fxr2*, but not *Fmr1*, knockout mice are impaired on the context-dependent conditioned fear test, show poor performance during training of the Morris water task, and a decreased response to the heat stimulus on the hotplate test. In the original study by Peier *et al.* (26), *Fmr1* knockout mice were not tested for levels of sensorimotor gating. Recently, Chen and Toth (32) and K.L.McIlwain and L.A.Yuva-Paylor (personal communication) have shown that *Fmr1* knockout mice have enhanced prepulse inhibition, which is opposite of the impaired prepulse inhibition that is seen in the *Fxr2* knockout mice.

It is important to be cautious when comparing the behavioral results of the *Fmr1* and *Fxr2* knockout mice. Although the behavioral experiments were performed in the same laboratory using the same equipment, they were not performed simultaneously. There were likely to be environmental differences between the two studies that may have contributed differentially to the outcomes. It is clear that behavioral responses vary among mice of different genetic backgrounds (reviewed in 31). The behavioral studies of Peier *et al.* (26) were performed using *Fmr1* knockout mice on a C57BL/6 genetic background, while the current studies with the *Fxr2* knockout mice were performed using mice that were on a mixed genetic background (see Materials and Methods). It is extremely difficult to compare the responses of different mutant mice on different genetic backgrounds [also see Paradee *et al.* (29) and Dobkin *et al.* (28)]. These methodological differences between the studies with the *Fmr1* knockout and the *Fxr2* knockout mice do warrant caution; they do indicate that *Fxr2* and *Fmr1* contribute to several behavioral responses.

We have recently generated *Fmr1/Fxr2* double knockout mice. We have used a breeding strategy that will generate *Fmr1*, *Fxr2*, and the *Fmr1/Fxr2* double knockouts that are littermates and therefore all on the same type of genetic background. The *Fmr1/Fxr2* double knockout mice will be useful for testing the hypothesis that the gene products from *Fmr1* and *Fxr2* complement/interact with each other. If this hypothesis is accurate, then we should see some behavioral responses that are exaggerated in the *Fmr1/Fxr2* double knockouts when compared to the individual *Fmr1* and *Fxr2* knockout mice (e.g. open-field activity). In contrast, there may be some responses that are not present in the *Fmr1/Fxr2* double knockouts because the two individual gene knockout phenotypes are in opposing directions (e.g. prepulse inhibition). It is also possible that a deficiency in both *Fmr1* and *Fxr2* will produce behavioral responses that are not observed in either single-gene knockout. Regardless of the outcome of the behavioral studies with the *Fmr1/Fxr2* double knockout mice, we believe that the findings from these double knockout mice will provide important insight into the relationship between the function of FMRP and the FXR proteins, and increase our understanding of how these interactions might contribute to fragile X syndrome.

FXR2P has not been associated with any known human disease. Based on the phenotype found for the *Fxr2* knockout mice, it will be interesting to test whether, in humans, an autosomal recessive form of mental retardation is caused by the absence of FXR2P.



## MATERIALS AND METHODS

### Targeting construct and ES cell electroporation

A human *FXR2* cDNA was used to screen the mouse cosmid library CCE to identify the mouse *Fxr2* cDNA. A number of overlapping cosmids almost completely covering the *Fxr2* gene were identified. A 11 kb *Bam*HI fragment containing introns 3–13 was used to generate the targeting construct pCB33. The 11 kb *Bam*HI fragment was cloned into pBluescriptKS with the *Neo* cassette cloned in the antisense orientation into the *Bgl*II site thereby deleting exon 7. The *tk* cassette was cloned into the *Sal*I site of pBluescriptKS. The targeting construct pCB33 is depicted in Figure 1.

The targeting construct pCB33 was linearized by *Cl*AI to allow homologous recombination of the plasmid with ES cell DNA. Electroporation was performed using  $10^7$  ES cells in 400  $\mu$ l PBS using a Progenetor II Gene Pulser (1200  $\mu$ F and 117 V for 10 ms). Selection of transfectants was performed by selecting for the presence of the *neo* cassette with G418 (200  $\mu$ g/ml) and the absence of the *tk* cassette with FIAU (2  $\mu$ M). After cells were cultured to promote colony formation, the colonies were picked and cultured individually. From each clonal colony, half was frozen and half was used for DNA isolation to identify homologous recombination events.

### DNA analysis

PCR and Southern blot analysis was performed on all isolated ES cell clones to identify homologous recombination events. PCR was performed using primers *neof* (5'-CCTGCGTGAC-CCCACAGGTCC-3') and *fxr2AB* (5'-CTGTAAGGATTGCT-GTCTGGATCC-3'). Cycle conditions were 2 min at 94°C, 18 $\times$  (10 s at 94°C, 30 s at 60°C, 3 min at 68°C), 19 $\times$  (10 s at 94°C, 30 s at 60°C, 200 s per cycle at 68°C), 15 min at 68°C using the Expand Long Template PCR System (Boehringer Mannheim, buffer 3). For Southern blot analysis ES cell DNA was digested with *Bgl*II. As a probe for Southern blot hybridization the PCR fragment generated with primers *fxr2e4* (5'-GCGGATGATGAAGGGAGATG-3') and *fxr2iR* (5'-GGACAGAGCTGGCACTGTG-3') was used. Cycle conditions were 5 min at 94°C, 30 $\times$  (30 s at 95°C, 30 s at 60°C, 90 s at 72°C), 10 min at 72°C using standard PCR buffers.

ES cells positive for the homologous recombination event were injected into C57BL/6J blastocysts which were implanted in pseudopregnant C57BL/6J females. The mice were shipped to Baylor College of Medicine where they were embryo rederived before testing behavior.

### Immunohistochemistry

*Fxr2* knockout and wild-type mice ( $n = 4$ ) were anaesthetized and killed by perfusion fixation with 3% paraformaldehyde for 10 min. Various organs were dissected, including brain, testes, liver, spleen, heart, muscle, kidney and lung with post fixation in 3% paraformaldehyde overnight. Tissues were embedded in paraffin according to standard protocols. Paraffin sections (5  $\mu$ m) were examined for gross abnormalities using hematoxylin and eosin staining.

For immunocytochemistry, paraffin sections of wild-type and *Fxr2* knockout tissues were deparaffinized followed by microwave treatment in 0.01 M sodium citrate solution.

Endogenous peroxidase activity was inhibited by 30 min incubation in PBS-hydrogen peroxide-sodium azide solution. Sections were incubated with rabbit polyclonal antibodies (1937) against FXR2P to study the presence of cross-reactive material in the *Fxr2* knockout mice (24). In addition, the expression pattern of the two homologs, *Fmrp* and *Fxr1p*, using monoclonal and polyclonal antibodies, respectively (24,33), was also examined. Furthermore, to study pathological abnormalities within the brain in more detail we used antibodies against specific markers, including neurofilament-H (SMI31), microtubule associated protein-2 (MAP-2), Tau protein and synaptophysin. Subsequently, an indirect immunoperoxidase technique was performed using 3,3'-diaminobenzidine-HCl as a substrate. Sections were also counterstained with haematoxylin, dehydrated with ethanol and mounted with Entellan.

### Behavioral studies

**Animals.** A total of 56 F2 (129/Ola: FVB: C57BL/6J) male mice were used for the experiments. Mice that tested positive for the presence of the *rd/rd* mutation were excluded (28). Two distinct replicate batches of mice were tested. In batch A there were 11 wild-type and 14 mutant mice. In batch B there were 16 wild-type and 15 mutant mice. The mice were housed in a room with a 12:12 h light:dark schedule with lights on at 0600 with access to food and water ad libitum. Mice were housed and tested in accordance with NIH policies on use of animals in research and all behavioral testing procedures have been approved by the Animal Protocol Review Committee at Baylor College of Medicine.

### Behavioral tests

Male mice were subjected to a standard test battery originally reported by Crawley and Paylor (31) using procedures described in McIlwain *et al.* (34). The order of testing has been designated from least invasive to most invasive (34). Mice began testing at 10 weeks of age.

### Neurological screen

The mouse was placed into an empty cage and observed for 1 min. Several behavioral responses were assessed (i.e. wild running, freezing, licking, jumping, sniffing, rearing, movement throughout the cage, urination and defecation). Postural reflexes were then evaluated by first determining if the mouse splayed its limbs in response to rapid vertical and horizontal cage movement. The righting reflex, whisker touch response, eye blink and ear twitch were then evaluated. Several simple motor responses were evaluated using a wire suspension test and a vertical pole test. In the wire suspension test, the mouse was suspended from a single wire (2 mm) by its forepaws, with hang time on the wire scored for a maximum of 60 s. In the vertical pole test, a mouse was placed facing up on a cloth-tape-covered pole (1.9 cm diameter, 43 cm long). The end of the pole was then lifted to a vertical position and the time a mouse stayed on the pole was recorded for a maximum of 60 s. These values are converted to a pole test score: fell before the pole reached 45° or 90° angle = 0 or 1, respectively; fell in 0–10 s,

2; 11–20 s, 3; 21–30 s, 4; 31–40 s, 5; 41–50 s, 6; 51–60 s, 7; stayed on 60 s and climbed halfway down the pole, 8; climbed to the lower half of the pole, 9; climbed down and off in 51–60 s, 10; 41–50 s, 11; 31–40 s, 12; 21–30 s, 13; 11–20 s, 14; 1–20 s, 15. During each test any abnormal behavioral responses, such as hind limb clutching, were recorded. The mouse was then weighed and its body temperature assessed using a rectal probe (Thermalert TH-5). Other physical features were recorded including the presence of whiskers, bald hair patches, palpebral closure, exophthalmos and piloerection.

### **Locomotor activity in the open-field**

One week after the neurological screen, locomotor activity was evaluated by placing mice into an open-field arena. Each subject was placed in the center of a clear Plexiglas (40 × 40 × 30 cm) chamber and allowed to explore for 30 min. Room lighting was provided by overhead incandescent light to approximately 800 lux inside the test chamber. In addition, white noise was present in the room at ~55 dB inside the test chamber. Activity in the open-field was recorded and quantitated by a computer-operated Digiscan optical animal activity system [RXYZCM (16), Accuscan Instruments] containing 16 photoreceptor beams on each side of the arena, which divides the arena into 256 equally-sized squares. Total distance (locomotor activity), vertical activity (rearing measured by number of photobeam interruptions) and centre distance (i.e. the distance traveled in the center of the arena) were recorded. The center distance was also divided by the total distance to obtain a center distance/total distance ratio. The center distance/total distance ratio can be used as an index of anxiety-related responses (26). Data were collected at 2 min intervals over the 30 min test session.

### **Rotarod test**

Motor coordination and balance were tested 1 week later using an accelerating rotarod (UGO Basile Accelerating Rotarod). The rotarod test was performed by placing a mouse on a rotating drum and measuring the time each animal was able to maintain its balance walking on top of the rod. Some mice held on to the rotating drum as they began to fall and rode completely around the rod. For these mice, the latency to the first complete revolution was recorded. The speed of the rotarod accelerated from 4 to 40 r.p.m. over a 5 min period. Mice were given four trials with a 20 min intertrial rest interval. The mice were returned to their home cage during each intertrial rest interval.

### **Startle and prepulse inhibition of the startle**

One week after rotarod testing, prepulse inhibition of the acoustic startle responses was measured using the SR-Lab System (San Diego Instruments, San Diego, CA) as described previously (35). A test session began by placing a mouse in the Plexiglas cylinder where it was left undisturbed for 5 min. A test session consisted of seven trial types. One trial type was a 40 ms, 120 dB sound burst used as the startle stimulus. There were five different acoustic prepulse plus acoustic startle stimulus trials. The prepulse sound was presented 100 ms before the startle stimulus. The 20 ms prepulse sounds were 74, 78, 82, 86

and 90 dB. Finally, there were trials where no stimulus was presented to measure baseline movement in the cylinders. Six blocks of the seven trial types were presented in pseudorandom order such that each trial type was presented once within a block of seven trials. The average intertrial interval was 15 s (ranged from 10 to 20 s). The startle response was recorded for 65 ms (measuring the response every 1 ms) starting with the onset of the startle stimulus. The background noise level in each chamber was 70 dB. The maximum startle amplitude recorded during the 65 ms sampling window was used as the dependent variable. Animals that did not have an average maximum startle amplitude of 100 were excluded from the analyses. The value of 100 is ~2-fold higher than the average measurement taken assessed during the NO Stimulus trials. This exclusion criterion is based on several years of experience in Dr Paylor's laboratory studying the startle response in mice.

The following formula was used to calculate the percentage of prepulse inhibition of a startle response:  $100 - [(startle\ response\ on\ acoustic\ prepulse\ plus\ startle\ stimulus\ trials / startle\ response\ alone\ trials) \times 100]$ . Thus, a high percentage prepulse inhibition value indicates good prepulse inhibition, i.e. the subject showed a reduced startle response when a prepulse stimulus was presented compared to when the startle stimulus was presented alone. Conversely, a low percentage prepulse inhibition value indicates poor prepulse inhibition, i.e. the startle response was similar with and without the prepulse.

### **Habituation of the acoustic startle response**

One week later, habituation of the acoustic startle response was measured. One hundred startle stimuli (120 dB, 40 ms) were presented to each mouse. The average interstimulus interval was 15 s. The maximum response to each stimulus was recorded.

### **Pavlovian conditioned fear**

Two to three weeks later performance in a conditioned fear paradigm was measured as described by Paylor *et al.* (36) using a Freeze Monitor system (San Diego Instruments). Although this test chamber has been validated for scoring of conditioned fear in mice (37), the data presented here are derived from experimenters that were blind to the genotype during testing. The test chamber (26 × 22 × 18 cm high) was made of clear Plexiglas and surrounded by a photobeam detection system (12 × 10 beams). The floor of the test chamber was a grid floor used to deliver an electric shock. The test chamber was placed inside a sound attenuated chamber (Med Associates, internal dimensions: 56 × 38 × 36 cm). Mice were observed through windows in the front of the sound attenuated chamber. A mouse was placed in the test chamber (house lights 'ON') and allowed to explore freely for 2 min. A white noise (80 dB), which served as the CS, was then presented for 30 s followed by a mild (2 s, 0.5 mA) foot-shock, which served as the unconditioned stimulus (US). Two minutes later another CS-US pairing was presented. The mouse was removed from the chamber 15–30 s later and returned to its home cage. Freezing behavior was recorded using the standard interval sampling procedure every 10 s. Responses (run, jump and vocalize) to the foot-shock were recorded. Animals that did not respond to the foot-shock were excluded from analysis.

Twenty-four hours later, the mouse was placed back into the test chamber for 5 min and the presence of freezing behavior was recorded every 10 s (context test). During training and context test, the chambers were cleaned with 50% ethanol. Two hours later, the mouse was tested for its freezing to the auditory CS. Environmental and contextual cues were changed for the auditory CS test: a black plexiglass triangular insert was placed in the chamber to alter its shape and spatial cues, red house lights replaced the white house lights, the wire grid floor was covered with black plexiglass and vanilla extract was placed in the chamber to alter the smell. Finally, the sound-attenuated chamber was illuminated with red house lights. During the CS test the chamber was cleaned with isopropyl alcohol. There were two phases during the auditory CS test. In the first phase (pre-CS), freezing was recorded for 3 min without the auditory CS. In the second phase, the auditory CS was turned on and freezing was recorded for another 3 min. The number of freezing intervals was converted to a percentage freezing value. For the auditory CS test, the percentage freezing value obtained during the pre-CS period was subtracted from the percentage freezing value when the auditory CS was present.

### Spatial learning in the Morris water task

Two weeks later, mice were trained in the Morris water task (38) to locate a hidden escape platform in a circular pool (1.38 m diameter) of water (39). Each mouse was given eight trials per day, in blocks of four trials for four consecutive days. The time taken to locate the escape platform (escape latency) and the distance traveled were determined. After trial 32, each animal was given a probe trial. During the probe trial, the platform was removed and each animal was allowed 60 s to search the pool. The amount of time that each animal spent in each quadrant was recorded (quadrant search time). The number of times a subject crossed the exact location of the platform during training was determined, and compared with crossings of the equivalent location in each of the other quadrants (platform crossing).

Selective search data in the probe trial were analyzed by individual one-way (quadrants) repeated ANOVAs and Newman-Keuls post-hoc comparison tests. A two-way (genotype  $\times$  gender) ANOVA was used to compare the quadrant search time and platform crossing data for the training quadrant only between mutant and wild-type mice.

### Hotplate test

Two weeks later, the hotplate test was used to evaluate the sensitivity to a painful stimulus. Mice were placed on a 55°C ( $\pm$  0.3) hotplate, and the latency to the first hind-paw response was recorded. The hind-paw response was either a foot shake or a paw lick.

### Data analyses

Data for the various behavioral paradigms were analyzed using two-way (genotype  $\times$  batch) or three-way (genotype  $\times$  batch  $\times$  repeated measure such as time) analysis of variance (ANOVA). Post-hoc comparisons were made using Newman-Keuls or simple effects tests. Significance was set at  $P < 0.05$ .

## ACKNOWLEDGEMENTS

We like to thank N.Galjard for providing the CCE cosmid library and R.van Haperen for blastocyst injections. This study was supported by the Netherlands Organization for Scientific Research (NOW) and by the National Institute of Health (NIH 5 RO1 HD38038 and 5 P30 HD26024).

## REFERENCES

- Turner,G., Webb,T., Wake,S. and Robinson,H. (1996) The prevalence of the fragile X syndrome. *Am. J. Med. Genet.*, **64**, 196–197.
- De Vries,B.B., van den Ouweland,A.M., Mohkamsing,S., Duivenvoorden,H.J., Mol,E., Gelsema,K., van Rijn,M., Halley,D.J., Sandkuijl,L.A., Oostra,B.A. *et al.* (1997) Screening and diagnosis for the fragile X syndrome among the mentally retarded: an epidemiological and psychological survey. Collaborative Fragile X Study Group. *Am. J. Hum. Genet.*, **61**, 660–667.
- Hagerman,R.J. (1996) Physical and behavioral phenotype. In Hagerman,R.J. and Silverman,A.C. (eds), *Fragile X Syndrome: Diagnosis, Treatment and Research*. The John Hopkins University Press, Baltimore and London, pp. 3–87.
- Oberlé,I., Rousseau,F., Heitz,D., Kretz,C., Devys,D., Hanauer,A., Boue,J., Bertheas,M.F. and Mandel,J.L. (1991) Instability of a 550-base pair DNA segment and abnormal methylation in fragile X syndrome. *Science*, **252**, 1097–1102.
- Verkerk,A.J., Pieretti,M., Sutcliffe,J.S., Fu,Y.H., Kuhl,D.P., Pizzuti,A., Reiner,O., Richards,S., Victoria,M.F., Zhang,F.P. *et al.* (1991) Identification of a gene (FMR-1) containing a CGG repeat coincident with a breakpoint cluster region exhibiting length variation in fragile X syndrome. *Cell*, **65**, 905–914.
- Fu,Y.H., Kuhl,D.P., Pizzuti,A., Pieretti,M., Sutcliffe,J.S., Richards,S., Verkerk,A.J., Holden,J.J., Fenwick,R., Jr, Warren,S.T. *et al.* (1991) Variation of the CGG repeat at the fragile X site results in genetic instability: resolution of the Sherman paradox. *Cell*, **67**, 1047–1058.
- Ashley,C., Jr, Wilkinson,K.D., Reines,D. and Warren,S.T. (1993) FMR1 protein: conserved RNP family domains and selective RNA binding. *Science*, **262**, 563–568.
- Feng,Y., Gutekunst,C.A., Eberhart,D.E., Yi,H., Warren,S.T. and Hersch,S.M. (1997) Fragile X mental retardation protein: nucleocytoplasmic shuttling and association with somatodendritic ribosomes. *J. Neurosci.*, **17**, 1539–1547.
- Kanamori,H., Dodson,R.E. and Shapiro,D.J. (1998) *In vitro* genetic analysis of the RNA binding site of vigilin, a multi-KH-domain protein. *Mol. Cell. Biol.*, **18**, 3991–4003.
- Siomi,M.C., Siomi,H., Sauer,W.H., Srinivasan,S., Nussbaum,R.L. and Dreyfuss,G. (1995) FXR1, an autosomal homolog of the fragile X mental retardation gene. *EMBO J.*, **14**, 2401–2408.
- Zhang,Y., O'Connor,J.P., Siomi,M.C., Srinivasan,S., Dutra,A., Nussbaum,R.L. and Dreyfuss,G. (1995) The fragile X mental retardation syndrome protein interacts with novel homologs FXR1 and FXR2. *EMBO J.*, **14**, 5358–5366.
- Coy,J.F., Sedlacek,Z., Bachner,D., Hameister,H., Joos,S., Lichter,P., Delius,H. and Poustka,A. (1995) Highly conserved 3'-UTR and expression pattern of FXR1 points to a divergent gene regulation of FXR1 and FMR1. *Hum. Mol. Genet.*, **4**, 2209–2218.
- Bakker,C.E., de Diego Otero,Y., Bontekoe,C., Raghoe,P., Luteijn,T., Hoogeveen,A.T., Oostra,B.A. and Willemsen,R. (2000) Immunocytochemical and biochemical characterization of FMRP, FXR1P, and FXR2P in the mouse. *Exp. Cell Res.*, **258**, 162–170.
- Tamanini,F., Meijer,N., Verheij,C., Willems,P.J., Galjaard,H., Oostra,B.A. and Hoogeveen,A.T. (1996) FMRP is associated to the ribosomes via RNA. *Hum. Mol. Genet.*, **5**, 809–813.
- Siomi,H., Siomi,M.C., Nussbaum,R.L. and Dreyfuss,G. (1993) The protein product of the fragile X gene, FMR1, has characteristics of an RNA-binding protein. *Cell*, **74**, 291–298.
- Khandjian,E., Corbin,F., Woerly,S. and Rousseau,F. (1996) The fragile X mental retardation protein is associated with ribosomes. *Nat. Genet.*, **12**, 91–93.
- Eberhart,D.E., Malter,H.E., Feng,Y. and Warren,S.T. (1996) The fragile X mental retardation protein is a ribonucleoprotein containing both nuclear localization and nuclear export signals. *Hum. Mol. Genet.*, **5**, 1083–1091.

18. Siomi, H., Matunis, M.J., Michael, W.M. and Dreyfuss, G. (1993) The pre-mRNA binding K protein contains a novel evolutionarily conserved motif. *Nucleic Acids Res.*, **21**, 1193–1198.
19. Brown, V., Small, K., Lakkis, L., Feng, Y., Gunter, C., Wilkinson, K.D. and Warren, S.T. (1998) Purified recombinant Fmrp exhibits selective RNA binding as an intrinsic property of the fragile X mental retardation protein. *J. Biol. Chem.*, **273**, 15521–15527.
20. Bardoni, B., Sittler, A., Shen, Y. and Mandel, J.L. (1997) Analysis of domains affecting intracellular localization of the FMRP protein. *Neurobiol. Dis.*, **4**, 329–336.
21. Fridell, R.A., Benson, R.E., Hua, J., Bogerd, H.P. and Cullen, B.R. (1996) A nuclear role for the fragile X mental retardation protein. *EMBO J.*, **15**, 5408–5414.
22. Tamanini, F., Kirkpatrick, L.L., Schonkeren, J., Unen, L., Bontekoe, C., Bakker, C., Nelson, D.L., Galjaard, H., Oostra, B.A. and Hoogeveen, A.T. (2000) The fragile X-related proteins FXR1P and FXR2P contain a functional nucleolar-targeting signal equivalent to the HIV-1 regulatory proteins. *Hum. Mol. Genet.*, **9**, 1487–1493.
23. Khandjian, E.W., Bardoni, B., Corbin, F., Sittler, A., Giroux, S., Heitz, D., Tremblay, S., Pinset, C., Montarras, D., Rousseau, F. et al. (1998) Novel isoforms of the fragile X related protein FXR1P are expressed during myogenesis. *Hum. Mol. Genet.*, **7**, 2121–2128.
24. Tamanini, F., Willemsen, R., van Unen, L., Bontekoe, C., Galjaard, H., Oostra, B.A. and Hoogeveen, A.T. (1997) Differential expression of FMR1, FXR1 and FXR2 proteins in human brain and testis. *Hum. Mol. Genet.*, **6**, 1315–1322.
25. Bakker, C.E., Verheij, C., Willemsen, R., Vanderhelm, R., Oerlemans, F., Vermey, M., Bygrave, A., Hoogeveen, A.T., Oostra, B.A., Reyniers, E. et al. (1994) Fmr1 knockout mice: a model to study fragile X mental retardation. *Cell*, **78**, 23–33.
26. Peier, A.M., McIlwain, K.L., Kenneson, A., Warren, S.T., Paylor, R. and Nelson, D.L. (2000) Overcorrection of FMR1 deficiency with YAC transgenics: behavioral and physical features. *Hum. Mol. Genet.*, **9**, 1145–1159.
27. D'Hooge, R., Nagels, G., Franck, F., Bakker, C.E., Reyniers, E., Storm, K., Kooy, R.F., Oostra, B.A., Willems, P.J. and Dedeyn, P.P. (1997) Mildly impaired water maze performance in male Fmr1 knockout mice. *Neuroscience*, **76**, 367–376.
28. Dobkin, C., Rabe, A., Dumas, R., El Idrissi, A., Haubenstock, H. and Brown, W.T. (2000) Fmr1 knockout mouse has a distinctive strain-specific learning impairment. *Neuroscience*, **100**, 423–429.
29. Pardee, W., Melikian, H.E., Rasmussen, D.L., Kenneson, A., Conn, P.J. and Warren, S.T. (1999) Fragile X mouse: strain effects of knockout phenotype and evidence suggesting deficient amygdala function. *Neuroscience*, **94**, 185–192.
30. Van Dam, D., D'Hooge, R., Hauben, E., Reyniers, E., Gantois, I., Bakker, C.E., Oostra, B.A., Kooy, R.F. and De Deyn, P.P. (2000) Spatial learning, contextual fear conditioning and conditioned emotional response in Fmr1 knockout mice. *Behav. Brain Res.*, **117**, 127–136.
31. Crawley, J.N. and Paylor, R. (1997) A proposed test battery and constellations of specific behavioral paradigms to investigate the behavioral phenotypes of transgenic and knockout mice. *Horm. Behav.*, **31**, 197–211.
32. Chen, L. and Toth, M. (2001) Fragile X mice develop sensory hyperreactivity to auditory stimuli. *Neuroscience*, **103**, 1043–1050.
33. Devys, D., Lutz, Y., Rouyer, N., Bellocq, J.P. and Mandel, J.L. (1993) The FMR-1 protein is cytoplasmic, most abundant in neurons and appears normal in carriers of a fragile X premutation. *Nat. Genet.*, **4**, 335–340.
34. McIlwain, K.L., Merriweather, M.Y., Yuva-Paylor, L.A. and Paylor, R. (2001) The use of behavioral test batteries: Effects of training history. *Physiol. Behav.*, **73**, 705–717.
35. Paylor, R. and Crawley, J.N. (1997) Inbred strain differences in prepulse inhibition of the mouse startle response. *Psychopharmacology*, **132**, 169–180.
36. Paylor, R., Tracy, R., Wehner, J. and Rudy, J.W. (1994) DBA/2 and C57BL/6 mice differ in contextual fear but not auditory fear conditioning. *Behav. Neurosci.*, **108**, 810–817.
37. Valentinuzzi, V.S., Kolker, D.E., Vitaterna, M.H., Shimomura, K., Whiteley, A., Low-Zeddies, S., Turek, F.W., Ferrari, E.A., Paylor, R. and Takahashi, J.S. (1998) Automated measurement of mouse freezing behavior and its use for quantitative trait locus analysis of contextual fear conditioning in (BALB/cJ x C57BL/6J)F2 mice. *Learn Mem.*, **5**, 391–403.
38. Morris, R.G.M. (1981) Spatial localization does not require the presence of local clues. *Learn Motiv.*, **12**, 239–260.
39. Upchurch, M. and Wehner, J.M. (1988) Differences between inbred strains of mice in Morris water maze performance. *Behav. Genet.*, **18**, 55–68.