

Decision analysis in the clinical neurosciences

Beslissingsanalyse in de klinische neurowetenschappen

PROEFSCHRIFT

Ter verkrijging van de graad van doctor
aan de Erasmus Universiteit Rotterdam
op gezag van de Rector Magnificus
Prof dr PWC Akkermans, M. Lit.
en volgens het besluit van het college van Dekanen.
De openbare verdediging zal plaatsvinden op
woensdag 26 januari 1994 om 15.45 uur

door
Diederik Willem Johan Dippel,
geboren te Utrecht.

PROMOTIECOMMISSIE

Promotores: Professor dr JDF Habbema
Professor dr H van Crevel

Overige leden: Professor dr CJJ Avezaat
Professor dr FGA van der Meché

Paranymfen: HMA van Gemert
ACM Meyer

Aan mijn ouders.

Chapters 4-10 consist of adapted versions of the following papers:

- Dippel DWJ, Vermeulen M, Braakman R, Habbema JDF. Transient ischemic attacks, carotid stenosis and an intracranial aneurysm. A decision analysis. *Neurosurgery*. Accepted for publication. (Chapter 4).
- Ter Berg JWM, Dippel DWJ, Habbema JDF, Bijlsma JB, Van Gijn J, Tulleken CAF, Willemse J. Treatment of intact familial intracranial aneurysms: A decision-analytical approach. *Neurosurgery* 1988; 23: 329-334. (Chapter 5).
- Dippel DWJ, Ter Berg JWM, Habbema JDF. Screening for unruptured familial intracranial aneurysms. A decision analysis. *Acta Neurol Scand* 1992; 86: 381-389. (Chapter 6).
- Ter Berg JWM, Dippel DWJ, Habbema JDF, Westermann CJJ, Tulleken CAF, Willemse J. Unruptured intracranial arteriovenous malformations with hereditary haemorrhagic telangiectasia. Neurosurgical treatment or not? *Acta Neurochirurgica* 1993; 121: 34-42. (Chapter 7).
- Dippel DWJ, Habbema JDF. Probabilistic diagnosis of normal pressure hydrocephalus and other treatable cerebral lesions in dementia. *J Neurol Sci*. In press. (Chapter 8).
- Dippel DWJ, Van Crevel H, Lindsay KW, Hijdra A, Habbema JDF. Management of subarachnoid hemorrhage: Individualized prognosis. Submitted for publication. (Chapter 9).
- Dippel DWJ, Van Crevel H, Lindsay KW, Hijdra A, Habbema JDF. Management of subarachnoid hemorrhage: Decision analysis. Submitted for publication. (Chapter 10).

Co-authors:

dr JWM ter Berg	Afdeling Neurologie, Maasland Ziekenhuis, Sittard,
dr JB Bijlsma	Klinisch Genetisch Centrum, Utrecht,
Prof dr R Braakman	Emeritus hoogleraar Neurochirurgie, Academisch ziekenhuis Dijkzigt, Rotterdam,
Prof dr H van Crevel	Afdeling Neurologie, Academisch Medisch Centrum, Amsterdam,
Prof dr J van Gijn	Afdeling Neurologie, Academisch Ziekenhuis Utrecht,
Prof dr JDF Habbema	Centrum voor Klinische Besliskunde, Erasmus Universiteit, Rotterdam,
dr A Hijdra	Afdeling Neurologie, Academisch Medisch Centrum, Amsterdam,
KW Lindsay, PhD FRCS	Department of Neurosurgery, Inst of Neurological Sciences, Glasgow,
Prof dr CAF Tulleken	Afdeling Neurochirurgie, Academisch Ziekenhuis Utrecht,
Prof dr M Vermeulen	Afdeling Neurologie, Academisch Medisch Centrum, Amsterdam,
dr CJJ Westermann	Afdeling Longziekten, St Antonius Ziekenhuis, Nieuwegein,
Prof dr J Willemse	Emeritus Hoogleraar Kinderneurologie, Academisch Ziekenhuis, Utrecht.

Contents

Chapter 1 Introduction	11
1.1 The present study	12
Chapter 2 Methods	15
2.1 Decision tree	15
2.2 Probabilities	19
2.3 Preferences for health outcomes	28
2.4 Expected utilities and sensitivity analysis	35
2.5 Related methods for prescriptive decision making	42
Chapter 3 A review of decision analyses in the clinical neurosciences	48
3.1 Methods	48
3.2 Results	50
3.3 Discussion	62
Chapter 4 Transient ischaemic attacks, carotid stenosis and an intracranial aneurysm	64
4.1 Patients and methods	65
4.2 Available data and estimates	68
4.3 Results	72
4.4 Discussion and conclusions	77
Chapter 5 Treatment of intact familial intracranial aneurysms	79
5.1 Patients	79
5.2 Methods	80
5.3 Available data and estimates	81
5.4 Results	83
5.5 Discussion	85
Chapter 6 Screening for unruptured familial intracranial aneurysms	87
6.1 Material and Methods	87
6.2 Available Data and Estimates	91
6.3 Results	93
6.4 Discussion and conclusions	97
Chapter 7 Unruptured intracranial arteriovenous malformations	100
7.1 Patients and Methods	101
7.2 Available data and estimates	104
7.3 Results	106
7.4 Discussion	110
Chapter 8 Probabilistic diagnosis of normal pressure hydrocephalus	112
8.1 Patients and methods	112
8.2 Results	121
8.3 Discussion	124
Chapter 9 Individualized prognosis in subarachnoid haemorrhage	128
9.1 Material and methods	128
9.2 Results	132
9.3 Discussion	141
Chapter 10 Management of subarachnoid haemorrhage	145
10.1 Material and methods	146
10.2 Results	153
10.3 Discussion	159

Chapter 11 General discussion	162
11.1 Intracranial aneurysms and arteriovenous malformations	163
11.2 Probabilistic diagnosis of normal pressure hydrocephalus	164
11.3 Subarachnoid haemorrhage	165
11.4 The role of decision analysis in the clinical neurosciences	166
References	170
Summary	188
Samenvatting	192
Acknowledgements	197
Curriculum vitae	199
List of publications	200

Figures

Chapter 2: Decision tree	16
Decision tree	17
Decision tree	18
Decision tree	19
Probability estimation	20
Incidence of SAH and prevalence of aneurysms	23
Distribution of hypothetical test results	26
Decision tree: a binary test	28
Standard reference gamble	30
Utility function for life years	32
Partitioned survival curves	35
One-way influence analysis	36
Two-way influence analysis	37
Threshold analysis	38
Distribution function of the expected utilities	41
Cumulative distribution of the difference in EU	41
ROC curve	43
Influence diagram	44
Chapter 3: Medline search strategy	49
Clinical decision analyses in the neurosciences	62
Chapter 4: Decision tree	67
Partitioned survival curves	73
Sensitivity analysis	75
Full Bayesian analysis	76
Bayesian influence analysis	77
Chapter 5: Pedigrees	80
Decision tree	81
Threshold analysis	86
Chapter 6: Pedigree	88
Decision tree	90
Sensitivity analysis	96
Chapter 7: Pedigree	102
Decision tree	103
Threshold analysis	109
Chapter 8: Decision tree	120
Sensitivity analysis	122

Probabilistic diagnosis	122
Decision tree (folded back)	123
Threshold analysis	124
Chapter 9: Cumulative risks	137
Estimated risks for each profile	139
Prognostic chart	141
Chapter 10: Decision tree	149
Cumulative risks	155
Sensitivity analysis	157
Threshold analysis	159

Tables

Chapter 2: Estimates for the decision analysis	24
Likelihood-ratios and posterior odds	26
Results of the decision analysis	35
Parameters for the Bayesian analysis	40
Chapter 3: Decision analyses in the clinical neurosciences	59
Chapter 4: Patients	65
Estimates	69
Expected utilities	71
Chapter 5: Patients	79
Estimates	83
Expected utilities	83
Sensitivity analysis	84
Chapter 6: Estimates	92
Expected utilities	94
Sensitivity analysis	95
Chapter 7: Three patients	101
Estimates	106
Results	107
Sensitivity analysis	108
Chapter 8: Clinical profiles	113
Prior probabilities	116
Feature probabilities	118
Diagnostic probabilities	121
Chapter 9: Clinical characteristics	133
Overall results	135
Proportional hazards model	136
Competing risks model	140
Chapter 10: Patients	147
Available data and estimates	150
Results for the key patient	154
Expected utilities	158

Chapter 1

Introduction

Diagnostic and therapeutic choice in neurology can fortunately be made without formal decision support in the majority of cases. In many patients a diagnosis and treatment choice are relatively easy to establish. This study however, concerns the application of a decision support methodology - clinical decision analysis - to several problems in the clinical neurosciences where diagnosis, prognosis and therapeutic choice are not obvious.

Sometimes decision making in clinical medicine can be extremely difficult. There may be large interests at stake, and the amount of information that has to be processed can be enormous. Data from the patient's history, physical examination, diagnostic procedures, clinical knowledge and the scientific information have to be combined in order to arrive at a prognosis and to develop a diagnostic and therapeutic strategy. Add to this that most diagnostic tests are not completely accurate, that therapy is not always and entirely effective, that diagnostic and therapeutic procedures may be risky, unpleasant, expensive and time-consuming, and that prognosis is most of the times uncertain.

The decision process itself is limited by time and by budgetary constraints. The clinician has to recognize situations where the patient's preferences are important, and he has to know when the clinical situation needs a doctor - patient relationship characterized by activity - passivity, guidance - cooperation or mutual participation.³⁹² Moreover, physicians and their patients (as any human being) find it difficult to handle uncertainty.³⁷⁹ Clinicians often discuss the pro's and con's of alternative management strategies with their senior and junior colleagues, but a language that effectively and explicitly addresses uncertainty and preferences for health outcomes is not part of the physician's standard equipment. Several other factors influence the decision process as well. It has been demonstrated that patient characteristics, (such as social class), physician's personal characteristics (such as age, type of specialty), and the physician's interaction with his profession (for example whether he is in a solo- or group-practice) all may be of influence.^{67,68,106,392}

Is there a need for clinical decision analysis, or more in general, for formal decision support in neurology? This question is best answered by introducing a clinical situation from one of our own studies (Chapter 4):

A 69-year-old man presents with a history of transient weakness of the left arm and face. Carotid angiography^a revealed a 50% stenosis of the right internal carotid artery,^b and surprisingly, a 5 mm saccular aneurysm^c of the right posterior communicating artery.^d What should be done now?

The transient ischaemic attacks (TIA)^g are probably related to the carotid stenosis, but it is possible that the aneurysm is the source of thrombo-embolism^f causing the TIA. Carotid endarterectomy^g has a risk of surgical complications, and its effectiveness in preventing stroke^h has not been proven for patients with moderate carotid stenosis.^{284,170} The aneurysm poses a problem in itself. It may rupture, causing subarachnoid haemorrhage (SAH),ⁱ with grave consequences.^{203,169} On the other hand, an intracranial operation to 'clip' the aneurysm may lead to immediate morbidity and even mortality. Should this patient receive acetyl-salicylic acid (ASA)?^j This drug decreases the risk of stroke and of myocardial infarction, but increases the risk of complications from SAH.

The clinical problem is quite complex and there are several therapeutic options with uncertain consequences. It illustrates that there is a need for refined treatment and management advice, based on all the available information, taking into account the attitude of the patient towards the possible consequences of treatment. Inevitably, clinicians will be increasingly confronted by choice situations that are characterized by complexity and uncertainty. The need for support will grow, because of the expansion of medical knowledge, the increase in diagnostic and therapeutic possibilities, the increasing quality demands by the public, and the increasing pressure towards cost-containment.

Decision analysis can be used to produce a treatment advice for the management of individual patients, but also to derive more general guide-lines for similar patients, based on a rational and explicit assessment of risks and benefits of different management strategies. The methodology consists of an intriguing mixture of mathematics and decision theory. Decision analysis is rational in the sense that it attempts to describe a course of action that is consistent with the decision maker's goals and expectations and maximizes the decision maker's expected satisfaction.³⁴⁵ Several applied sciences such as biostatistics and clinical epidemiology come together here, applied to real clinical problems. Decision analysis is a normative theory, used for prescriptive purposes, with foundations in probability theory and the theory of subjective expected utility.³¹⁵ It should be stressed that clinical decision analysis should not be seen as the panacea to the ailments of human decision making, but merely as a tool, that can be used when decisions are difficult.¹⁴⁸

1.1 The present study

This study describes the results of research in the application of decision analysis in the clinical neurosciences. The aim of each of our studies is the synthesis of general clinical knowledge and preferences for health outcomes to derive guide-lines for the clinical management of individual patients, using a normative model of rational choice, using the subjective expected utility model. In Chapter 2 the methodology of clinical decision analysis is described

and discussed, followed by a brief survey of related methods for formal decision support. The introduction and first section of Chapter 2 are written in such a way that a basic understanding of the methodology is attained, and that the succeeding sections can be skipped when desired.

In Chapter 3 published applications of decision analysis in the clinical neurosciences will be reviewed. The following three chapters concern the management of intracranial aneurysms. Chapter 4 concerns patients like the one described in the first paragraph of this chapter, a man with transient ischaemic attacks, carotid stenosis and an intracranial aneurysm. Chapter 5 concerns patients with a familial intracranial aneurysm, detected after screening of a large family in which several subarachnoid haemorrhages had occurred. Chapter 6 discusses whether asymptomatic members of such a family should be advised to undergo angiography.

Chapter 7 considers the neurosurgical management of patients with unruptured arteriovenous malformations^k and hereditary haemorrhagic telangiectasia,^l with a generalization to patients with non-syndromal arteriovenous malformations.

In Chapter 8 the diagnostic management of patients with dementia is analysed, with emphasis on the diagnosis and treatment of normal pressure hydrocephalus.^m

Chapter 10 contains a decision analysis of the management of patients with subarachnoid haemorrhage that compares the options of early and delayed surgery, and the use of antifibrinolytics.ⁿ Most of the data for the decision analysis are based on a re-analysis of a randomized clinical trial of antifibrinolytics against placebo, which is described in Chapter 9.

A general discussion of this work is presented in Chapter 11. It is followed by a summary in English and in Dutch. Statistical terms and techniques are explained in the text. Some explanatory notes and, for the convenience of the reader without a medical background, explanations of medical terms can be found at the end of each chapter.

Notes

- a. *Angiography is an invasive procedure where contrast-fluid is injected via a catheter through an artery in the leg (the Seldinger technique) and the lumen of the arteries is visualized by X-rays.*
- b. *A stenosis or narrowing of the lumen of the carotid artery, which is one of the two main arteries in the neck that each supply a hemisphere, via the circle of Willis, is mostly caused by athero-sclerosis and aggregations of platelets (thrombus). It is associated with the occurrence of transient ischaemic attacks (see below) and stroke.*
- c. *An aneurysm is an abnormal saccular distension of an artery, mostly located at an arterial bifurcation, near the circle of Willis. Sizes range from several millimetres to centimetres. Aneurysms may rupture, and cause subarachnoid haemorrhage.*
- d. *The posterior communicating arteries connect the posterior cerebral arteries, that arise from the basilar artery with the carotid arteries. Together with these vessels, and with the anterior cerebral arteries they form the circle of Willis, at the base of the brain. Most aneurysms are located here.*

- e. *Transient ischaemic attacks are episodes of sudden neurologic deficit with undisturbed consciousness, with symptoms resolving within one day, due to (partly) reversible focal brain ischemia. They are associated with an increased risk of stroke, and can be considered as a warning sign. Examples are transient loss of vision of one eye, transient weakness of an arm, leg or face.*
- f. *Thrombo-embolism refers here to the process where parts of a thrombus (a mass platelets, fibrine, and sometimes atheromatous material, of platelet-aggregation and formation of fibrine, are released into the bloodstream, and will plug distant arteries, leading to insufficient flow, and hence to ischaemia and necrosis of part of the brain.*
- g. *Carotid endarterectomy is the surgical procedure where the carotid artery is clamped, and the lumen and its endothelial covering is cleaned from atherosclerotic material.*
- h. *Stroke is a general term for a sudden focal deficit, due to haemorrhage or (in this case) ischaemia of parts of the brain.*
- i. *In subarachnoid hemorrhage blood (from trauma, ruptured arteriovenous malformations or aneurysms) is located between the meninges of the brain.*
- j. *Acetyl-salicylic acid (and derivatives, such as carbasalate calcium) decreases platelet aggregation and thrombus formation, and thus has a preventive effect on stroke and myocardial infarction, in patients at risk. The drug is also known by its brand name Aspirin®.*
- k. *An arteriovenous malformation consists of abnormal connections between arterial (afferent) and venous (efferent) vessels, without the usual capillary network. When located in the head, it can cause seizures, headache, focal neurological deficits and intracranial haemorrhage.*
- l. *An autosomal dominant disease named after Rendu, Osler and Weber, with arteriovenous malformations and fistulae that may involve numerous organs in the body. The brain may be compromised through hypoxia, and (septic) emboli, or by an intracranial localization of the vascular malformations.*
- m. *Normal pressure hydrocephalus is a condition characterized by gait disturbances, dementia, and urinary incontinence. Some only consider the gait disturbances obligatory for the diagnosis. The ventricles of the brain are enlarged, but the cerebrospinal fluid pressure seems normal. The syndrome is one of the causes of dementia that are amendable to treatment.*
- n. *Antifibrinolytics such as tranexamic acid inhibit the conversion of plasminogen into plasmin, and therefore, the natural breakdown of fibrine an important constituent of a blood-clot or thrombus.*

Chapter 2

Methods

Decision analysis is a normative theory of decision making under conditions of uncertainty, used for prescriptive purposes.²⁸ It distinguishes a decision maker, who is usually the expert who acknowledges the decision problem, and wants help in structuring the choice situation and making the decision.⁴ The decision analyst helps with explicitly formulating and structuring the problem. This is the first, crucial and often the most difficult step in the analysis. In the structuring process, the choices that are perceived by the decision maker are laid down in a decision tree. The decision tree provides a scenario of possible events that may occur after a decision is made; it is used to avoid misunderstanding and promote uniformity in representing a decision problem.

After the construction of a decision tree, the phases of a decision analysis consist of:

- assessment of relevant probabilities and utilities,
- the necessary calculations,
- presentation of the results of the analysis in a useful way.¹⁴⁸

In reality, this is a process with many jumps back and forth again.

A clinical decision analysis differs from decision analysis in general because of a confusing number of interested parties and potential decision makers. Apart from the treating physician and the patient as reasonable candidates for the position of "decision maker", there are - on a more aggregate level - the third party payers and insurance companies, the hospital board and the general public. Although a decision analysis can have any perspective, the perspective of the individual patient is adopted throughout this study. That is, approximations of patients' preferences for health outcomes are used. Estimates of the likelihood of events in a decision tree are based on general medical knowledge available in the clinical literature, clinical-epidemiological research, and expert opinion.

2.1 Decision tree

Through the remainder of this introduction we will use parts of the decision analysis of the management of a patient with symptomatic carotid stenosis and TIA's (see also Chapter 4) to illustrate the methodology, and to establish a basis for discussion.

For the patient in the example, there are four main strategies: wait, clipping of the aneurysm, endarterectomy and both clipping of the aneurysm and endarterectomy. For each strategy, acetyl-salicylic acid (aspirin) can be given as well. Figure 1 shows the root of the decision tree, depicting the four main strategies. In Figures 2, 3 and 4 the four strategies are visualized.

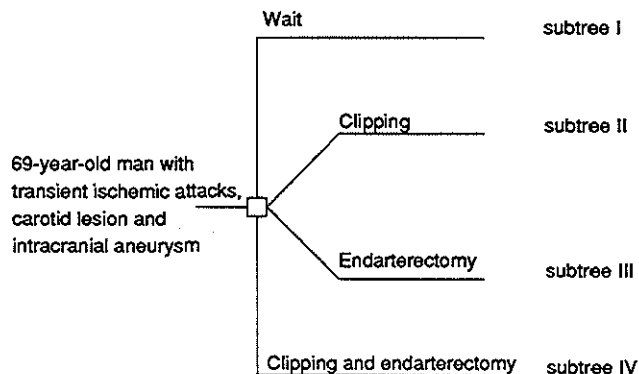

Figure 1. Root of the decision tree for the management of a patient with TIA's and ipsilateral carotid stenosis.

In the example, a major stroke may occur, resulting in death or permanent disability, or the aneurysm may rupture, resulting in death, disability or recovery. When the patient is operated, surgery may be successful, or may be complicated by mortality or morbidity, resulting in permanent disability.

A decision tree consists of interconnected decision nodes (quadrangles), chance nodes (circles) and terminal or outcome nodes (rectangles). Time flows from left to right. The decision node represents the point where the first choice must be made by the decision maker. The outcomes that result from previous events and decisions are represented by a terminal node. Chance nodes represent points where events take place that cannot be influenced directly by the decision maker, although their occurrence or likelihood may depend on previous decisions. Probabilities of mutually exclusive events are inserted at each branch of a chance node and should sum to unity, see also section 2.2. A quantitative measure of the patient's preferences for each health outcome (utility) relative to the worst and best outcome is inserted at each terminal node, see also section 2.3. The expected utility of each strategy is computed by multiplying the probabilities along each path in the tree with their associated utility, and adding the results for each strategy. The strategy with the highest expected utility is advised. Sensitivity analyses are used to assess the influence of uncertainty about the exact values of the probabilities by varying them over a plausible range, and examining the effect on the expected utility of each strategy. In this way, an impression of the stability, or robustness of the results of the analysis is obtained, see also section 2.4.

A decision tree is constructed by breaking down the problem and possible actions into smaller and smaller units. The structure of the decision tree must accommodate the rules of probability calculus and logic. It should contain a context and case description, be complete and pruned from unrealistic subtrees and it should be symmetrical. Branches should contain single, not complex actions. For a discussion of the construction and assessment of a decision tree, see Wellman.³⁶⁸ In the course of the process of decision tree construction there is a lot of switching back between too complex and too simple decision trees. In discussions with the decision analyst interesting alternatives that were first not thought of or were (prematurely) discarded as "unusual" sometimes emerge.

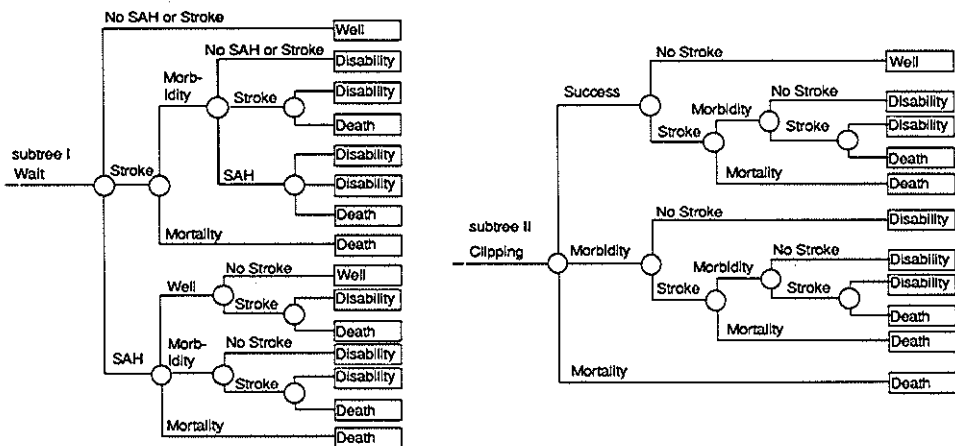

Figure 2. Decision tree for the management of a patient with TIA's and ipsilateral carotid stenosis: Wait and clipping strategies.

Decision analysis requires that uncertain factors in a clinical problem be made explicit and quantifiable. Most if not all of the estimates will be based on the literature, as usual in clinical practice. This type of analysis can be found in the Chapters 4-8. Many times however, a decision analysis is not merely directed at a unique patient problem, but can be used as a decision-support tool for similar patients. Probability estimates that are crucial to the analysis are then not merely inserted in the tree, but a diagnostic or prognostic prediction model is created. This has been done in Chapter 8, and in the Chapters 9 and 10. Thus, the decision analysis has become a natural extension of decision oriented data acquisition and analysis.

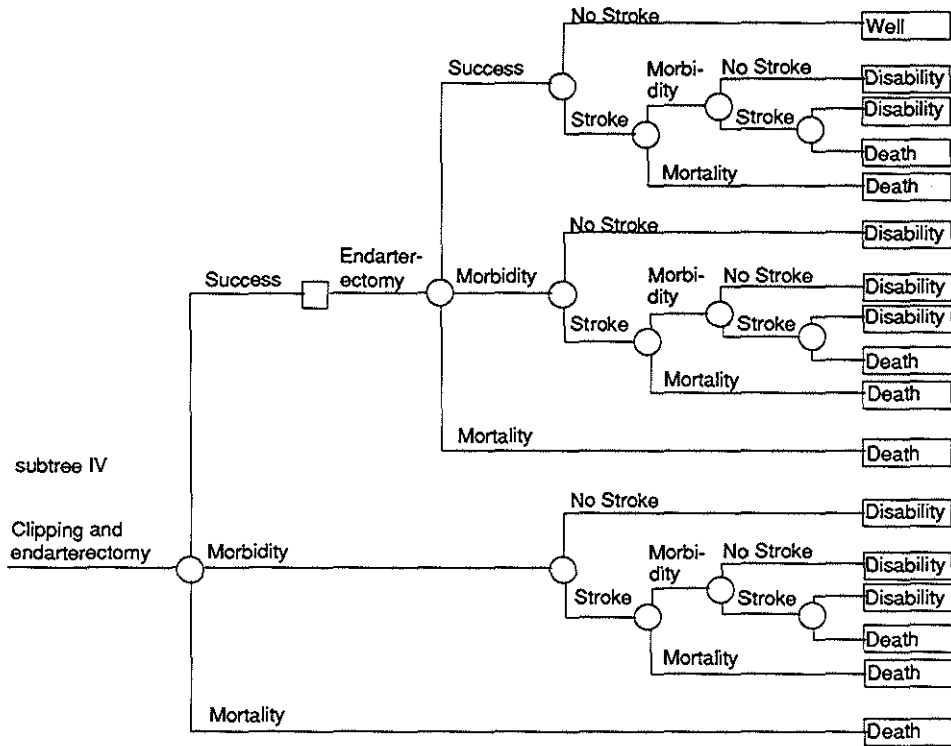

Figure 3. Decision tree for the management of a patient with TIA's and ipsilateral carotid stenosis: Endarterectomy.

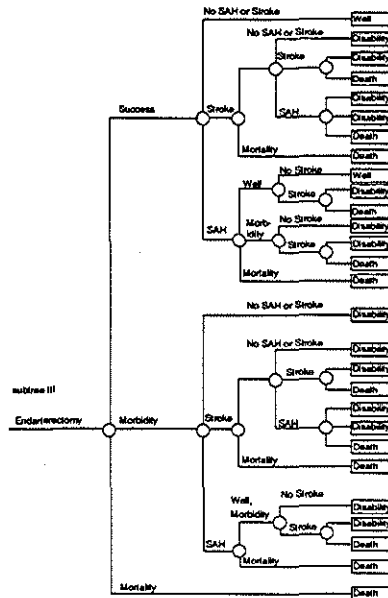

Figure 4. Decision tree for the management of a patient with TIA's and ipsilateral carotid stenosis: Clipping and Endarterectomy.

2.2 Probabilities

In choosing between the clinically relevant strategies one may want to consider the attractiveness of each outcome, and the chance that it occurs. In this section we will first go into the application of probability theory to decision making in medicine, and then return to the patient example. Probability is defined as the personal degree of belief of a decision maker in the truth of a statement, on a scale of 0-1. This implies that the subjective, Bayesian view of probability is adopted throughout this study.³⁴⁸ This is inevitable, as we cannot consider the practical use of decision theory without choosing this point of view.⁴¹⁵ A probability of 0 means that the statement is certainly not true, and a probability of 1 means the exact opposite. A probability of 0.5 implies that the statement is equally likely to be true as not true, according to the decision maker. The probabilities of an exhaustive set of mutually exclusive events sum to 1. Likewise, the probabilities that are inserted at the branches of a chance node should sum to unity.

In order to get a firm idea of the likelihood of a certain event, one might try to gather as much information as possible. This is where clinical epidemiology and biostatistics come in. Perhaps the decision maker has some experience with the clinical situation, and he thinks that the statement "the TIA is caused by thrombo-embolism from the intracranial aneurysm" is ten

times less likely to be true than not, implying a probability $P(T) = 0.09$.^b However, he is not certain about his own estimate. According to him, this probability might be as low as 0.05, or as high as 0.15. This is called 'secondary uncertainty'. Secondary uncertainty in decision analyses is sometimes represented by a 'plausible range', as has been done in some chapters of this book. Many authors regard the plausible range as an informal confidence range, specifying a range that encompasses the "true value" with 95% certainty. The former statement about the most likely cause of the TIA is not verifiable, and the uncertainty cannot be resolved...

In the other extreme situation the decision maker has carefully searched the literature instead of relying on personal experience and finds that in a consecutive series of 175 similar patients with an unruptured aneurysm 7 patients suffered peri-operative complications resulting in serious permanent disability. When the decision maker thinks that this represents all the available information, the most likely value for $P(Mb)$ is $7/175 = 0.04$. Ninety-five percent confidence limits can then be specified by taking for example the normal approximation to the binomial distribution.^c Exact limits are obtained from binomial tables¹³³ or by using the F-statistic approach^d according to Miettinen²² (see also Armitage)¹².

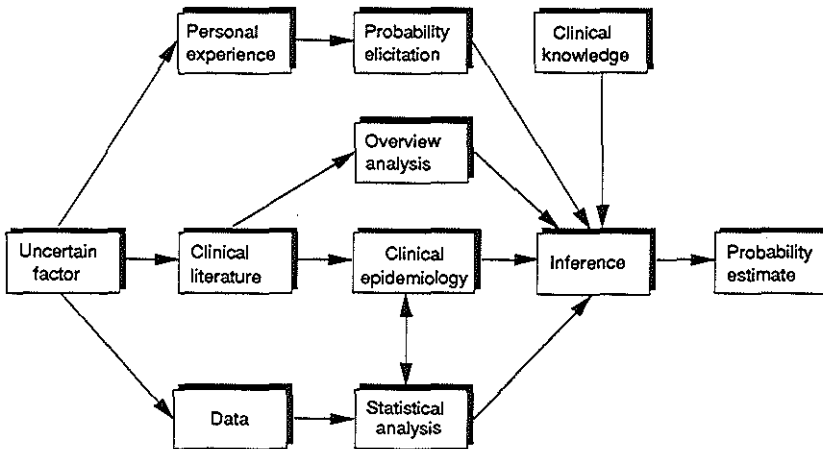

Figure 5. Probability estimation for a clinical decision analysis.

Sometimes, data are available that bear on the clinical problem that is addressed. But even in that fortunate situation, inference and adjustments are necessary, because the clinical characteristics (age, sex etc.) of the study population do not exactly match the characteristics of the key patient, and the data have been gathered in the past, and their applicability in the

present and near future has to be judged. Even the use of data from the national vital statistics⁵⁵ for estimation of the life expectancy of a patient requires a step of inference, because it is assumed that the (cross-sectional) age- and sex-specific mortality rates are still valid many years from now.

Always when a probability estimate has to be made, a step of inference is necessary, where it is judged whether the figures bear on the clinical situation under consideration. When the clinical literature is considered, the data should not be taken at face value, but selection and other bias mechanisms should be kept in mind. See for example Sackett^{328,329} and Begg.^{26,27} Publication bias refers to the fact that studies with significant results, low complication rates etc. have a higher chance of being published than studies with less favourable results. Adjustments may therefore be necessary. Several formal methods exist for combining study results. Meta-analysis is a general term for combining results from experimental studies using multivariate (logistic regression) techniques. Overview analysis is now used to denote the procedure of combining estimates of the effect size in a pooled odds-ratio using the Cochran-Mantel-Haenszel statistic.⁸⁰ The method is appropriate for combining the results of randomized clinical trials. Several modifications have been proposed, especially for base-rate and dosage differences.^{232,304} Eddy's confidence profile method uses Bayesian statistics to combine the evidence from different kinds of studies: cohort studies, case-control studies and randomized and non-randomized clinical trials. Distributions for a specific parameter are created, checked visually and combined mathematically.¹⁰⁴ Even when such formal methods are employed, or when only one or two sets of statistically analysed data are available, inference and interpretation is necessary. Thus, every probability estimate is subjective, whether it stems from a statistical analysis or not. Figure 5 shows the necessary steps in a schematic way.

Many times, a decision maker can only make vague statements about the likelihood of disease. This is not more than natural, as most of us do not seem to think of likelihood in quantitative terms.^{37,348} Vague, verbal statements concerning likelihoods are of no use in a decision analysis. Thus, the analyst has to elicit probabilities from the expert. The process consists of *a*) comparing with well known relative frequencies, *b*) narrowing down and *c*) multiple consistency checks.³⁹³ This is certainly necessary, as it has been demonstrated that people are subject to many biases when making probability judgments.³⁷⁹

Sometimes information is difficult to obtain, because of costs and time, or methodological constraints. A logical approach would be to obtain expert judgment of probabilities, and examine by sensitivity analyses whether more information on a certain factor in the analysis would be of influence.

Whether a probability estimate is produced by a clinical expert, a prediction rule or a computer program, it should have two properties: The first is obvious, but nevertheless sometimes neglected: extremeness. An estimate close to zero or to one gives far more guidance

than an assessment near 50%. The other desirable property is calibration. When the risk of serious permanent disability $P(Mb)$ is estimated in N "identical" patients, surgery should actually lead to serious disability in $P(Mb) \times N$ patients. Calibration and extremeness pull in opposite directions. Well calibrated probability assessments can be worthless, when for example in every situation an estimate of approximately 0.5 is given. The calibration of a single estimate cannot be assessed.⁶ This is why probability estimates in a decision analysis of the management of an individual patient may give rise to (endless) discussion. A body of theory has developed around the evaluation of diagnostic (and prognostic!) rules, see others.^{144,145,146,173,174,234,393}

Paradoxical situations may result from taking the viewpoint of subjective probability. Imagine two independent decision teams analyzing the same clinical problem. They arrive at different estimates of a probability, and they produce different treatment advices, using the same data and information. This would not make one or the other estimate invalid, but it rather illustrates the limits of generalisability of these probability-estimates.

For the patient in the example, all estimates are based on clinical knowledge and the literature. For instance, the estimate of the annual rate^f of rupture was made by contemplating several follow-up studies of patients with unruptured aneurysms,^{164,189} by combining data on the age-specific population-incidence of SAH³⁰⁶ and prevalence of unruptured aneurysm²⁵⁸ (see Figure 6). The ratio of these two measures gives an estimate of the rate of aneurysm rupture. The most important conclusion is that it remains constant with increasing age. The actual value (0.5%) is probably an underestimate, because an unknown number of patients with sudden death (some of them due to subarachnoid haemorrhage, and many due to other vascular events) were not included in the survey, because no clinical or autopsy evidence was available. Cohort studies suggest an annual rate of rupture of 1% approximately.^{84,189,198} The risk of SAH from unoperated ruptured aneurysm was considered as a reasonable upper bound of the plausible range of values.⁴¹⁰ In Table 1 all estimates for the decision analysis are summarized. For a discussion of these estimates and of the clinical literature, see Chapter 4.

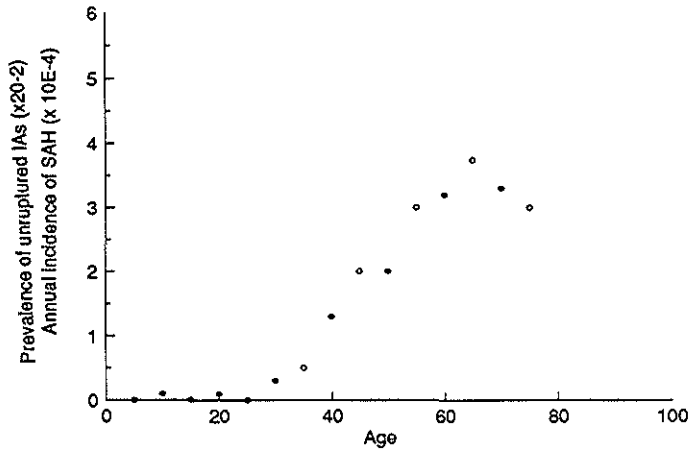

Figure 6. Age-adjusted prevalence of unruptured intracranial aneurysms²⁵⁸ (open circles) and population incidence of subarachnoid haemorrhage³⁰⁶ (closed circles).

Diagnostic testing

Doing a test, for example a CT-scan of the brain to look for signs of hydrocephalus in a demented patient with gait abnormalities (see Chapter 8), or a duplex scan of the carotid arteries in a patient with TIA's in order to judge whether an arteriogram should be obtained and perhaps endarterectomy should follow, may give additional information about the existence of disease in a patient. When a test predicts with certainty that the patient has the disease or not, it is said to offer perfect information. When it is also free of costs and causes no harm, it is called a perfect test. Most tests however, are not. Assessment of clinical signs and symptoms can be considered as a relatively cheap, fast and simple battery of tests³⁹⁶ (especially in neurology),¹⁹ although they almost never offer perfect information and observer variability is sometimes large.^{233,234}

Many test results can be expressed as continuous variables, for example cerebrospinal fluid cell count (cells/3 mm³), creatinine-phospho-kinase level in serum (U/l), or as categorical variables on an ordinal scale. The ability of test results to discriminate between disease and non-disease can be expressed as a likelihood-ratio (*LR*); i.e. the ratio of the probability of a certain test result T^* given the presence of disease (D), and the probability of a certain test result given the absence of disease (\bar{D});

Table 1. Estimates for the decision analysis of the management of a 69-year old man with an unruptured intracranial aneurysm, TIA's and ipsilateral carotid stenosis.

	Point value	Plausible range
Stroke and myocardial infarction		
Annual rate of major non-fatal stroke	3%	(2%-4%)
Annual rate of fatal stroke	1.5%	(1%-2%)
Annual rate of fatal myocardial infarction	3%	(2%-4%)
Likelihood that the TIA is caused by the aneurysm	25%	(5%-50%)
Endarterectomy		
Mortality	2%	(1%-4%)
Morbidity	4%	(2%-8%)
Efficacy	50%	(25%-75%)
Subarachnoid haemorrhage		
Annual rate	1%	(.5%-2%)
Mortality	55%	(50%-60%)
Morbidity	15%	(10%-20%)
Aneurysm surgery		
Mortality	1%	(0.5%-2%)
Morbidity	4%	(3%-6%)
Acetyl-salicylic acid		
Efficacy (vascular death)	15%	(10%-20%)
Efficacy (non-fatal stroke)	30%	(20%-40%)
Increase in mortality and morbidity from SAH	5%	(1%-10%)

$$LR = \frac{P(T^* | D)}{P(T^* | \bar{D})} \quad (1)$$

The likelihood-ratio can be combined with the prior odds in favour of disease (before the test result is known) $(P(D)/(1 - P(D)))$ or $P(D)/P(\bar{D})$ in order to compute the posterior odds (the odds in favour of disease, given the test result), using Bayes' rule or theorem:

$$\frac{P(D | T^*)}{P(\bar{D} | T^*)} = LR \cdot \frac{P(D)}{P(\bar{D})} \quad (2)$$

For those who do not like to think in odds, Bayes' theorem can be written as

$$P(D | T^*) = \frac{P(T^* | D) \cdot P(D)}{P(T^*)} \quad (3)$$

and

$$P(\bar{D} | T^*) = \frac{P(T^* | \bar{D}) \cdot P(\bar{D})}{P(T^*)} \quad (4)$$

where

$$P(T^*) = P(T^* | D) \cdot P(D) + P(T^* | \bar{D}) \cdot P(\bar{D}) \quad (5)$$

Many textbooks on statistics and epidemiology describe this formula and its derivation, see for example Hays¹⁶¹ or Ingelfinger.¹⁸⁷

Figure 7 shows a hypothetical distribution of test results in diseased and non-diseased. Table 2 gives the likelihood-ratio and posterior odds for each test category of results, and for different prior odds. It clearly demonstrates the effect of different priors. The table shows how easy the computations with the odds and likelihood-ratios are.

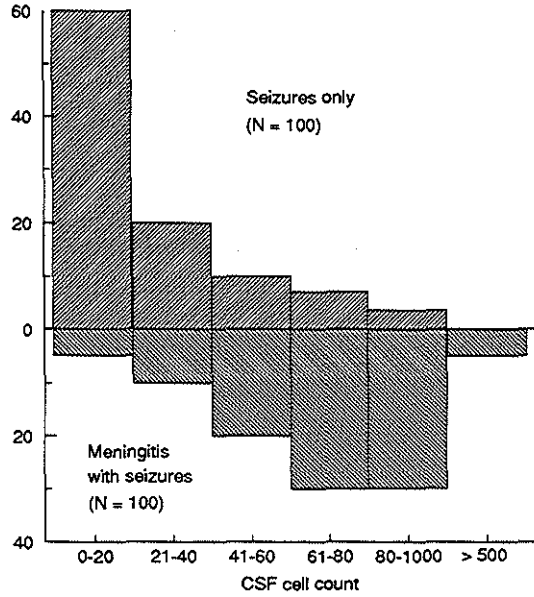

Figure 7. Distribution of hypothetical test results. X-axis: CSF-cell count (cells/3 mm³) in 100 patients with seizures and meningitis^a (lower bars) and 100 patients with seizures only (upper bars).

Table 2. Hypothetical likelihood-ratios and posterior odds for different categories CSF-cell count in patients with seizures and meningitis and seizures only.

Test result	LR	posterior odds			
		prior = 1/1000	prior = 1/10	prior = 1	prior = 10
10	1/12	1/12000	1/120	1/12	1/1.2
30	1/2	1/2000	1/20	1/2	5
50	2	1/500	1/5	2	20
70	3	1/333	1/3.33	3	30
200	6	1/167	1/1.67	6	60
1000	∞	∞	∞	∞	∞

A decision rule is now easy to make. The choice of a cut-off point above which test results should be regarded as indicative of disease is determined by the benefits and loss of treatment of and no treatment of disease and non-disease, and the prior odds. Determining a cut-off point before the prior is known is a futile effort.

The ability of a diagnostic test to discriminate between disease and non-disease is determined by comparison with a gold standard; i.e. an independent procedure that denotes the right diagnosis with certainty.^h

Some prefer to describe test characteristics by sensitivity, i.e. the probability that the test is positive when the patient has the disease, or $P(T^+ | D)$ and specificity, i.e. the probability that the test is negative when the patient does not have the disease, or $P(T^- | \bar{D})$. When the test results are represented by continuous variables the use of sensitivity and specificity implies a cut-off point, above which test results are regarded as indicative of disease, and below as indicative of non-disease. When this "cut-off" level is low, the sensitivity will be high and the specificity low, and when the cut-off level is high, the other way around. Trade-offs between sensitivity and specificity can be visualized by ROC-analysis, which will be further discussed in Chapter 2, section 2.5.^{178,260,270,285} The use of these concepts means loss of information, as any result (whether extreme or not) below the cut-off value is considered to mean the same thing. Sometimes, these simplifying concepts can be useful, for example when estimates of test-characteristics have to be made with scarce data, see Chapter 8. In general, it is unreasonable to consider the test characteristics as parameters that are independent of the clinical context where the test was evaluated. Generally there will be a relation between the severity of signs and symptoms, referral and prevalence of disease.²¹³

Bayes' rule can be generalized to the case of (n) diseases $D_1, \dots, D_i, \dots, D_n$, and m tests $T_1, \dots, T_j, \dots, T_m$.

$$P(D_i | T^*) = \frac{P(D_i) \cdot P(T^* | D_i)}{\sum_{k=1}^n P(D_k) \cdot P(T^* | D_k)}, \quad (6)$$

where T^* stands for a particular combination of test results, its probability computed using the simplified form of Bayes' rule:^l

$$P(T^* | D_k) = \prod_{j=1}^m P(T_j | D_k). \quad (7)$$

In order to relax the assumption of conditional independence, which is implied by Bayes' theorem, a global association factor ($0 \leq x \leq 1$) can be used.¹⁴⁴

$$P(T^* | D_k) \propto \left(\prod_{j=1}^m P(T_j | D_k) \right)^x \tag{8}$$

(\propto means "is proportional to").

A value $x = 1/m$ suggests that all tests are completely dependent, $x = 1/2$ suggests pairwise dependence, and $x = 1$ suggests conditional independence.

In Chapter 8 the base 2 log-odds form of Bayes' theorem is used because of its computational ease when more than one test is involved:

$$\text{posterior likelihood} = {}^2\log \left(\frac{P(D_i | T^*)}{1 - P(D_i | T^*)} \right) = {}^2\log \left(\frac{P(D_i)}{1 - P(D_i)} \right) + x \cdot {}^2\log \left(\frac{P(T^* | D_i)}{P(T^* | \bar{D}_i)} \right), \tag{9}$$

where $LR = P(T^* | D_i) / P(T^* | \bar{D}_i)$ is the likelihood ratio for a test with result T^* :

Figure 8 shows part of decision tree that represents the use of the diagnostic test. In a non-trivial problem, treatment will follow a positive test result, and no treatment a negative test result.

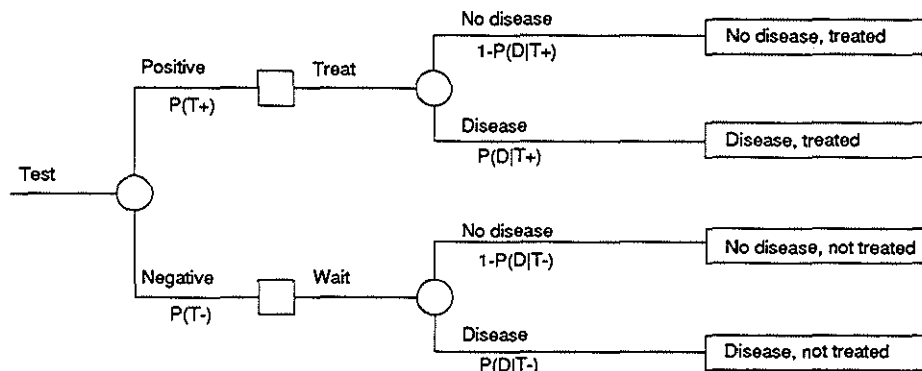

Figure 8. A binary test.

2.3 Preferences for health outcomes

Health outcomes can have several attributes that are pertinent to a decision problem, for example, duration of life, and quality. Quality of life itself has numerous attributes, physical, psychological and socio-economical. An attribute can have one or more levels, for example the attribute duration of life can have the levels 0,1,2,...,i,...,n years. In a non-trivial decision problem,

outcomes have at least one attribute, with at least two levels. Of course, only those attributes that will be affected by the decision should be taken in to consideration (the sure thing principle, see further).

In the one attribute, two levels situation, the construction of a utility scale is trivial, and the analysis is merely a risk analysis. The two attributes, two levels situation is also a special case: when the preferences for the two attributes are independent, one may decide not to create a utility scale for the different health levels, but to compute a ratio of expectations of levels. This is called a risk-benefit ratio.^j In the one attribute, more than two levels situation a utility scale is necessary to compare strategies, when there is no dominance.^k

In the example there are two attributes, duration of life and quality of life, with numerous and three levels, respectively. The relative attractiveness of the three outcomes can be represented by numerals, called utilities, on a scale of 0 to 1. For example, the utility of the outcome "disability" in the decision tree is represented by $U(\text{Disability})$. The central axiom of utility theory and decision analysis is that a decision maker should maximize the expected utility. The expected utility of each option is computed by taking the sum of all path probabilities multiplied by the utility of their outcome.

Now, the decision maker is advised to choose strategy Wait when $EU(\text{Wait}) > (EU(\text{Clipping}) \geq EU(\text{Endarterectomy}) \geq EU(\text{Clipping and Endarterectomy}))$, and strategy Clipping when $EU(\text{Clipping}) > (EU(\text{Wait} \geq EU(\text{Endarterectomy}) \geq EU(\text{Clipping and Endarterectomy}))$. This is the main axiom of subjective expected utility theory.

Utility should not be confused with the quality of life measurements in patients with stroke, cancer and other chronic, potentially disabling conditions.^{75,111,183,245,356,414} Utility is a measure of the strength of preference for a certain unresolved outcome in the presence of uncertain alternatives. The assessment of these preferences presumes an adequate description of these outcomes. However, information from quality of life studies can be valuable in the assessment of utilities.

Utility is defined as the substitution probability of a hypothetical standard reference gamble.^{393,396} Assume that (immediate) death is the least attractive, and "well" is the most attractive outcome. These will be given the (arbitrary) values 0 and 1.^l The utility of the intermediate outcome (i.e. $U(\text{Disability})$) is defined as a hypothetical choice situation presented to the decision maker, see Figure 9. The decision maker is then requested to choose between A , which may lead to immediate death with a probability $1-r$, or to recovery (with a probability r) and B , resulting in permanent disability. For very high values of r one would certainly prefer to wait, and for very low values to treat. It is theoretically possible to think of a unique value of r , that leads to indifference between the two options, in other words, $EU(A) = EU(B)$. This

implies that $(1 - r) \cdot 0 + r \cdot 1 = U(\text{Disability})$. The value of r that leads to indifference between the two strategies for the decision maker in a standard reference gamble, is called the substitution probability for $U(\text{Disability})$.

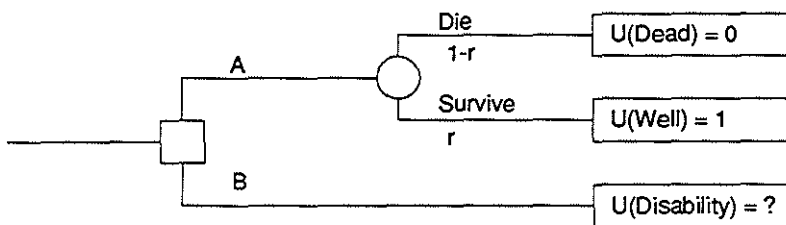

Figure 9. Standard reference gamble.

In the example, the decision maker distinguishes two attributes of the outcomes, i.e. quality, determined by the absence or presence of disability and duration of life in years. Theoretically, a countless number of different outcomes is possible, as the patient may die any time after the decision has been made. How should utilities for these outcomes be assessed?

First the underlying assumptions of utility theory will be described. They will be presented informally, in words, for the exact mathematical formulation the reader is referred elsewhere.^{118,315,393,396}

Connectivity: The decision maker can indeed make judgments about indifference or preference when faced with two risky choices.

Transitivity: When A is preferred over B, and B is preferred over C, then it follows that A is preferred over C.

Sure thing: When A and B have one component or attribute in common (for example a duration of 10 years) then preferences for A compared to B should not depend on the strength of preference $U(10 \text{ years}, q)$. Thus, when the patient learns that he will never reach retirement with any of the two options, this should not influence his choice.³⁹³

In a decision problem with uni-dimensional outcomes the standard reference gamble may be used to elicit preferences directly. Mostly however, the multi-attributed outcomes and their associated gambles are too complex, and the decision maker cannot express preferences or indifferences, or major violations of the assumptions of utility theory will follow.

The standard reference gamble is theoretically the most attractive method for utility elicitation, because it directly provides the decision analyst with a substitution probability. In practice, however, patients are anxious and emotionally disturbed. They may turn out to be inconsistent in their preferences, or not able to digest information. Moreover, the procedure of utility elicitation may provide information on future events that have a negative utility in themselves (for example the knowledge of harbouring an unruptured aneurysm).^m Hilden pointed out that the option of living a fixed amount of years that is frequently used in standard reference gambles and other elicitation techniques, is abstract and may even be abhorring to some.¹⁷⁷

Some have advocated other elicitation techniques, such as visual-analog scaling or direct scaling, the time trade-off method,^{257,309,373,374} and conjoint measurement.²⁴⁶ In visual-analog scaling the respondent is presented with two extreme conditions, and he should indicate his preference for a third intermediate condition by placing it on a 0-1 or 0-100% scale in between the two extremes. In the time trade-off method the respondent is asked how many life years he is willing to give up, in order to prevent living in a certain disease state, instead of living a normal healthy life. In conjoint measurement, the respondent should choose repeatedly between sets of two alternatives, and a utility function is fitted to his answers. The latter has the advantage of relatively easy elicitation procedures and "built-in" consistency checks.²⁴⁶

It appeared that different methods of elicitation led to different utility-values.³¹⁶ This can be explained by the fact that most people do not have a fixed number in their heads that only needs to be "drawn out" or elicited. Moreover, elicitation techniques that do not consider preferences for outcomes in the presence of uncertain alternatives, by definition do not measure what is needed.

In view of the above mentioned difficulties in utility elicitation, a pragmatic approach seems appropriate. This pragmatic approach is adapted from Von Winterfeldt³⁹³ and Weinstein,³⁹⁶ and employed in most of our studies (Chapters 4-7, and 10).

1. Determine the attributes of the outcome, i.e. duration life and health status.
2. Try to find a natural scale for each attribute, i.e. number of life years lived or age attained.
3. Attach values to the levels of the natural scale or levels of the attribute that adequately represent preferences in the face of uncertainty.
4. Perform the necessary computations and sensitivity analyses.
5. Only when the results of the analysis depend on the exact values of the utilities, an attempt to elicit utilities should be made.

Utility functions for life years

In many applications, life years lived (LY) form an attractive natural scale. However, even when disability does not play a role, life years lived are almost never a good single decision

criterion. A utility function for life years can have the simple form $U = t$, where t is the number of life years lived. It can easily be shown that this function does not adequately represent preferences for duration of life. According to this function, a decision maker should be indifferent between a gamble of living ten years in full health or dying immediately, both with a probability of 50%, and living for five years with certainty. McNeil investigated this problem in patients with lung-cancer and concluded that they generally opt for the safe alternative, and are indifferent only when the safe alternative offers a much lower life expectancy than the risky one. In other words, they are in general risk-averse.²⁶² In the decision theoretic and psychological literature the term risk-aversion seems to be reserved for risk attitude with regard to the taking of immediate risks, such as in (immediate) surgery, but a better term would be aversion to early risk, or early risk aversion. Early risk-averse people have convex utility functions for life years, whereas early risk-seeking individuals have concave utility functions, see Figure 10.ⁿ That the connotation "early" is necessary is illustrated by the case of the cigarette smoker, who takes a (calculated) risk and reduces his life-expectancy, but may nevertheless have a convex (early risk-averse) utility curve. Early risk-aversion can be (partly) explained by psychological mechanisms (fear, regret and disappointment) and by discounting of future life years.

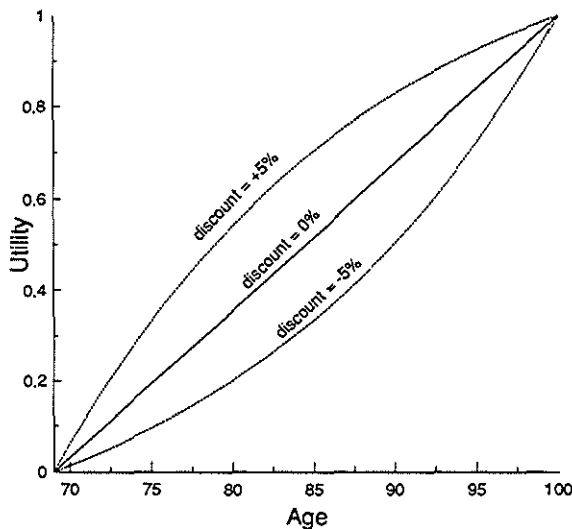

Figure 10. Utility function for remaining life years of a 69-year-old man, adjusted to a scale of 0-1, where $U(0) = 0$, and $U(31) = 1$.

When life years are used as a natural scale, a decision tree that displays all possible outcomes would be extremely "bushy", and therefore the expected number of years lived, or the life-expectancy of the patient is usually computed. This is done for a patient aged a years by summing for each subsequent year $t = 0, 1, \dots, 101 - a$ the product of the annual mortality m_t (the probability of dying before $t+1$ for a patient who is alive exactly at the start of year t), and t , the number of life years that has elapsed. In other words, it is the expected value of the survival time L_q . Alternatively one can sum the survival probabilities S_t over t (the probability of being alive, at least until time t), because $S_t - S_{t+1} = m_t$,

$$\sum_{t=0}^{101-a} m_t \cdot L_t \Leftrightarrow \sum_{t=0}^{101-a} S_t. \quad (10)$$

Preferences for time can be introduced by an annual discount rate α :

$$\sum_{t=0}^{101-a} S_t \cdot (1 - \alpha)^t. \quad (11)$$

An adjustment for the fact that patients do not die exactly at time t , but approximately halfway between t and $t+1$, can be made by doing the calculations in the previous formulas for t and for $t+1$, and averaging the result.

Quality adjusted life expectancy

Not only the risk of immediate death differs between the strategies, but also the risk of long-term disability. Figure 11 illustrates again why plain survival is not a good decision criterion: the overall and disability-free survival differ between the strategies. Therefore, quality- (or preference-) ¹⁸²adjusted life expectancy is computed by taking survival probabilities for each health state (Well, Disability) separately and weighing these with the utility u_h corresponding to the health state h ,

$$\sum_{h=1}^2 \sum_{t=0}^{101-a} S_{t,h} \cdot u_h (1 - \alpha)^t, \quad (12)$$

where $S_{t,h}$ is the probability of being alive and in health state h , at least until time t . The utility value of living with disability compared to death or a life without it of equal duration

can be estimated using a hypothetical standard gamble. In the example, $U(\text{Disability})$ is taken at 0.75, thus it is assumed that the hypothetical patient is willing to take any gamble with a risk of death versus normal life to prevent living with a severe handicap, where the risk of death is lower than 0.25.

This utility function presumes that utilities of health outcomes do not depend on duration of survival, and that discount does not depend on health state. The assumption of risk neutrality, implied by the use of time-trade-off techniques advocated by Torrance^{373,374} does not apply in our opinion, when it is modelled according to equation 12.¹³⁶

When it appears necessary to estimate utility functions one may use the standard reference gamble and fit the results to a utility function as described above, or use the approach suggested by Mehrez^{265,266,267} merely assess preferences for complete "lifetime health profiles", again using the standard reference gamble.^{129,195}

Regret⁹ and disappointment (and especially its anticipation) sometimes play a major role in human decision making. Regret is defined here as the psychological effect of comparing the realized outcome with the expectation of another choice that could have been made. Disappointment is defined as the psychological effect of comparing the realized outcome with prior expectations of the same choice.²⁹ In the unruptured aneurysm problem, the patient may anticipate on the experience of regret when he will become severely handicapped because of aneurysm surgery and realize that a choice for the conservative option would have quite probably given him several years more in good health. This may render the surgical option less attractive. Some argue that anticipated regret can at least partly explain discrepancies between results of descriptive and normative studies of human decision making.^{29,30} Anticipated regret thus defined has its basis in presumed foreknowledge of the result of an alternative, not-chosen strategy. We propose that a rational decision maker should not want to trade off (health-)benefits to achieve a state of higher psychological well-being. In our opinion the strength of clinical decision analysis lies in its prescriptive nature, based on rationality. Therefore, we incorporated neither regret nor disappointment in the utility functions of Chapters 4-8 and 10. Risk-attitude is considered only in so far it can be explained by discounting of future life years.

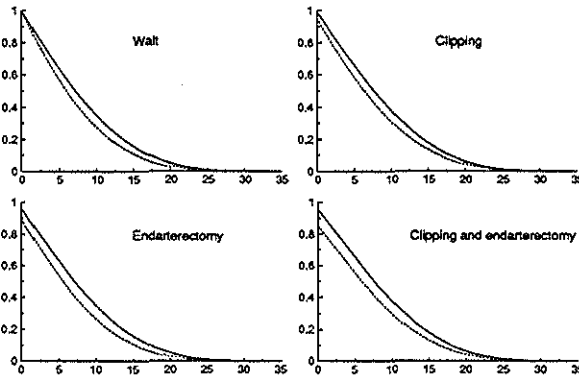

Figure 11. Partitioned, smoothed survival curves for a 69-year-old man with an unruptured intracranial aneurysm, TIA's and ipsilateral carotid stenosis, with four different treatment modalities. Dashed lines: disability-free survival, unbroken lines: overall survival. X-axis: time in years, Y-axis: proportion alive.

2.4 Expected utilities and sensitivity analysis

The expected utilities for each strategy are computed, using the utility function described in this section. In Table 3 expected utilities in the form of life expectancy (LE), discounted life expectancy (dLE), quality adjusted life expectancy (QALE) and discounted quality adjusted life expectancy (dQALE) are presented. Evidently, the results of the analysis are influenced by the way we constructed the utility scale, but in this case, the preferred strategy remains the same.

Table 3. Results of the decision analysis. Highest values for each method are underlined.

Strategies	Life expectancy			
	unadjusted	discounted	quality adjusted	discounted and quality adjusted
Wait	8.40	6.54	8.12	6.35
Aneurysm surgery	<u>8.82</u>	<u>6.79</u>	<u>8.52</u>	<u>6.59</u>
Endarterectomy	8.26	6.42	7.89	6.16
Endarterectomy and aneurysm surgery	8.66	6.66	8.28	6.39

In a sensitivity analysis the values of one or more parameters in the decision model will be varied over a plausible range, in order to examine the sensitivity of the decision to changes in one or more assumptions. In a one-way sensitivity analysis or influence analysis the value of only one parameter is changed, and the effect of these changes on the expected utility of each strategy is examined. One-way sensitivity analyses are used in Chapters 4-8 and 10 of this book. They can also be used in the "construction phase" of the decision analysis to check the model for internal consistency and logical or computational errors, but mostly, influence analyses are used to check the "robustness" or stability of the decision to plausible changes in estimates. Figure 12 shows the results of an influence analysis of changes in the mortality $P(M)$ associated with clipping of the aneurysm. This figure shows that changes in the mortality from clipping within the plausible range do not lead to different recommendations. Would this have been the case, and the plausible range was defined in the informal way as described previously, a problem with interpretation might have arisen, because the significance of deviations from the point estimate, within the plausible range would be unclear.

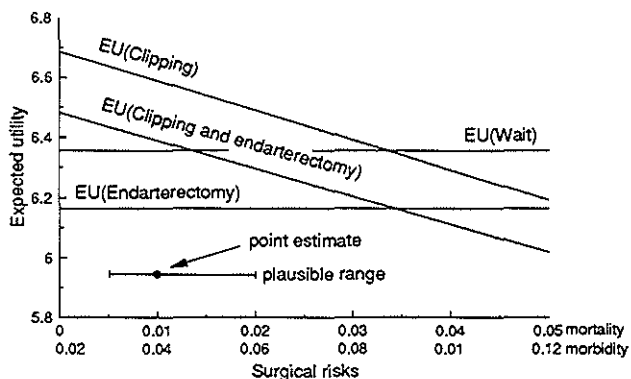

Figure 12. One way influence analysis. X-axis surgical mortality and morbidity.^P Y-axis: Expected utility in *Q*ALE. Black dot: base-case estimate.

Variation of more than one parameter at the same time (two- or more-way influence analysis) can lead to quite complicated graphs. When analysing the effect of plausible changes in two parameters $P(M)$ and $P(T)$ (the probability that the TIA originates from thrombo-embolism from the aneurysm), and on the expected utility of each strategy (Figure 13) simultaneously, one may determine the cutting edges of - for example - the two graphs for Clipping and Wait. The cutting edge is formed by a line in a plane that is parallel to the X-Y plane. It represents combination of values for $P(M)$ and $P(T)$, that lead to equal expected utilities for

both strategies. When only the intersection of the two planes is displayed in a figure, the analysis is called a threshold analysis, because at one side of the threshold or intersection combinations of values for the two parameters favour aneurysm surgery, and on the other side, waiting. Two- or more-way sensitivity analyses are not commonly used, because they are complicated and not easy to interpret visually. Threshold analyses are used in Chapters 5, 7, 8 and 10.

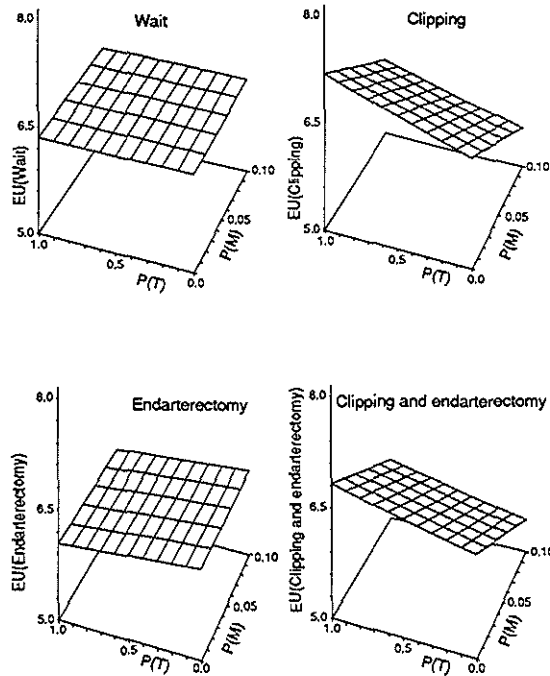

Figure 13. Two-way influence analysis: the effect of changes in the mortality from clipping $P(M)$ (X-axis) and the probability that the TIA is caused by thrombo-embolism from the intracranial aneurysm $P(T)$ (Y-axis) on the expected utility EU of each strategy (Z-axis).

A threshold analysis is sometimes (confusingly) called a two-way sensitivity analysis. Figure 14 shows how the threshold value of the mortality from clipping of the aneurysm changes with different values for $P(T)$, the probability that the TIA is caused by thrombo-embolism from the aneurysm.

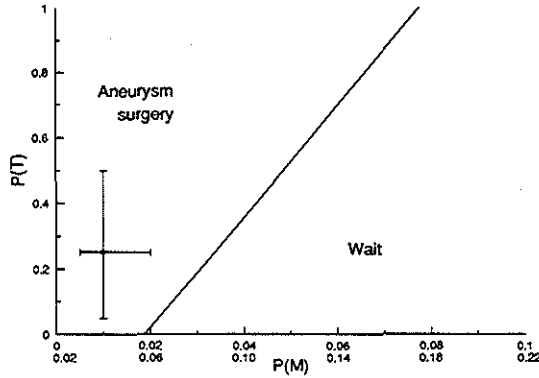

Figure 14. Threshold analysis. X-axis: probability that the TIA is caused by thrombo-embolism from the intracranial aneurysm P(T). Y-axis: Surgical mortality and morbidity. Straight line: Wait - Clipping threshold. The black dot represents the point estimates for the base-case, the bars represent the plausible ranges for each parameter.

The threshold analysis shows that no combinations of surgical risk and probability that the TIA's are caused by thrombo-embolism from the aneurysm within the plausible range favour WAIT. But what about combinations of values at the edge or out of the plausible range? What about the secondary uncertainty surrounding the other estimates in the analysis? How certain can we be about these results? In a probabilistic sensitivity analysis or full Bayesian analysis the uncertainty about each estimate is considered simultaneously. This type of sensitivity analysis is used in Chapter 4.

In a full Bayesian analysis cumulative distributions or density functions are estimated for all stochastic parameters in the decision model. They should represent the belief of the decision maker. The smaller the secondary uncertainty, the smaller the variance of the distributions. The purpose of the Bayesian analysis is to obtain probability distributions for the expected utility of each strategy, or a distribution for the difference in expected utility between the strategies. Others have suggested the percentage chance that one strategy is best (by a given amount), but this has been proven as insufficient and misleading when there are more than two strategies.¹³⁵ In a Monte Carlo simulation values for the parameters $p_i = p_1, \dots, p_n$ in the decision tree were randomly drawn from their probability distributions, inserted in the tree, and the expected utility based on these estimates was computed. By repeating this many (1000) times, distributions for the expected utility of each strategy, and for the difference in dQALE

between strategies could be approximated, see Figures 13 and 14. A Bayesian *influence* analysis (the Bayesian equivalent of a one-way sensitivity, or influence analysis) is obtained by repeating the Bayesian analysis for fixed values of one of the parameters p_i .¹⁴²

The distributions for each parameter were created by interpreting the point value as mean m , and the upper bound b of the plausible range as upper limit of a 95% confidence interval. The distributions have the form $F(x) = \Phi_{\mu, \sigma}(g(x))$, where $\Phi_{\mu, \sigma}$ is the normal distribution with mean μ and standard deviation σ , and $g(x)$ is a convenient transformation function. It is not true that $\mu = g(m)$, because $F(x)$ may be skewed. The mean m is given by the formula

$$m = \int_0^1 xF'(x)dx. \quad (13)$$

By taking $z = g(x)$, or equivalently $x = g^*(z)$ (where g^* is the inverse function of g) equation 11 can be rewritten as

$$m = \int_{-\infty}^{+\infty} g^*(z) \Phi_{\mu, \sigma}(z) dz, \quad (14)$$

where $\Phi_{\mu, \sigma}$ is the probability density function of the normal distribution. By definition,

$$\sigma = \frac{\mu - g(b)}{1.96}. \quad (15)$$

By solving these last two equations for μ and σ the distributions can be defined. Tertiary uncertainty can then be viewed as the uncertainty about the exact form of the distribution. For probabilities and utilities a logistic transformation is used, $g(x) = \ln(x/1-x)$, as described by Doubilet.⁹⁰ Table 4 lists for each parameter the point value, plausible range and characteristics of the associated probability distribution.

If we would only be interested in choosing the best strategy in one unique decision problem, we could have spared ourselves the trouble of formalizing secondary uncertainty, because this would not change the conclusion from the analysis. The expected utilities of the four strategies are 6.35, 6.59, 6.16 and 6.39 discounted quality adjusted life years, respectively.¹⁷⁸ They are (almost) equal to the means or expectations from the probabilistic sensitivity analyses. With

Table 4. Parameters for the Bayesian analysis (μ and σ represent the mean and the standard deviation of the transformed normal distribution).

	point value	plausible range	transformation	μ	σ
Stroke and myocardial infarction					
Annual rate of major non-fatal stroke	3%	2%-4%	ln(-ln)	1.44	0.036
Annual rate of fatal stroke	1.5%	1%-2%	ln(-ln)	1.25	0.044
Annual rate of fatal myocardial infarction	2.5% ^a	1.5%-3.5%	ln(-ln)	1.31	0.049
Probability that the aneurysm causes the TIA	25%	12.5-50%	logit	-1.17	0.597
Endarterectomy					
Mortality	2%	1%-4%	logit	-3.97	0.404
Efficacy	50%	25%-75%	logit	0	0.561
Subarachnoid haemorrhage					
Annual rate	1%	0.5%-2%	ln(-ln)	1.54	0.091
Morbidity	55%	50%-60%	logit	0.20	0.104
Mortality	15%	10%-20%	logit	-1.74	0.183
Aneurysm surgery					
Mortality	1%	0.5%-2%	logit	-4.69	0.408
ASA					
Efficacy (non-fatal stroke)	30%	20%-40%	logit	-0.86	0.230
Increase in mort./morb. from SAH	5%	1%-10%	logit	-3.03	0.423
Discounting and quality adjustment					
Annual discount rate	5%	0%-10%	ln	-3.07	0.393
Utility of disability	75%	62.5%-87.5%	logit	1.13	0.410

or without probabilistic information about the impact of secondary uncertainty, the option with the highest expected utility should be chosen, whether the difference between the strategies equals 0.001 utile or 0.01 utile, and whether the two distributions overlap for 9% or 99% of their area (see also Figure 15). However, when a decision is likely to be repeated in the near future, it would be pleasant and reassuring to know how certain one can be about the differences in expected utility from each strategy. The distributions of the differences in expected utility are shown in Figure 16. Clearly, the preferred strategy is Clipping.

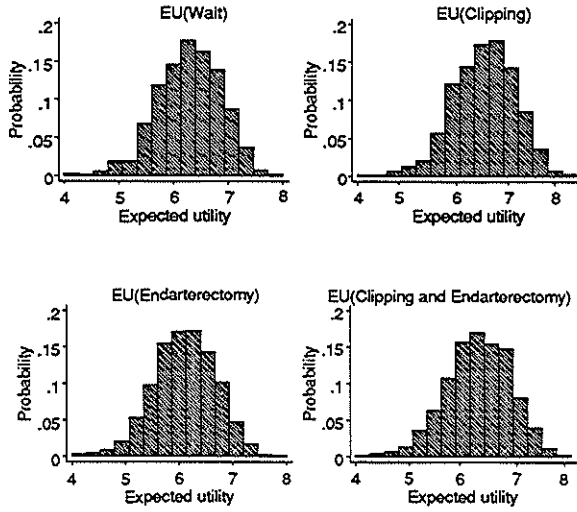

Figure 15. Distribution functions of the expected utility of the four strategies, derived from a Monte Carlo simulation.

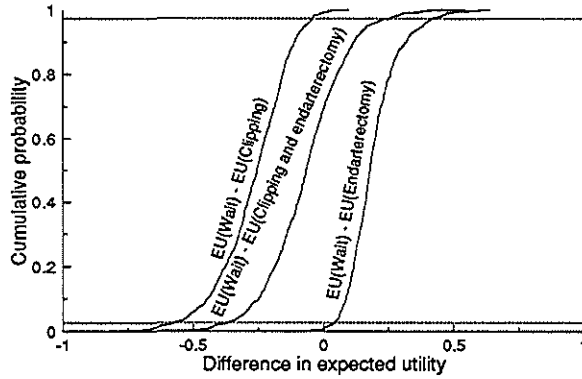

Figure 16. Cumulative distribution of the difference in expected utility between Wait and Clipping, Wait and Endarterectomy and Wait and Clipping and Endarterectomy, respectively. Dotted lines represent 95% confidence limits.

2.5 Related methods for prescriptive decision making

In this section we will briefly mention several other explicit, (semi-)quantitative methods for prescriptive decision making. Some, like cost-effectiveness analysis, ROC-analysis and influence diagrams are quite closely related with clinical decision analysis, and deserve to be mentioned on these grounds. The first two types of prescriptive decision making are employed in several studies that are outlined in Chapter 3. This concise review is of course not exhaustive. Operations research methods for specific problem types, such as Delphi methods for eliciting group opinion, queueing theory, solutions for the travelling salesman problem, linear modelling, etc. will not be discussed here.^{71,73}

ROC analysis

In continuous tests a cut-off level has to be defined, when only a dichotomous action (treatment-no treatment) can follow (see also section 2.2). In patients with seizures for example, 20 mono-nuclear cells per 3 mm³ cerebrospinal fluid (CSF) may be interpreted as a sign of meningitis or it may be discarded as "normal", because a cellular reaction may occur after seizures, head trauma, cerebral infarction and infection elsewhere in the body. Decreasing this so-called cut-off value will increase the sensitivity, but decrease the specificity of the test. Increasing the cut-off level will work the other way around.

ROC curves are graphs of sensitivity versus 1-specificity. They can be helpful in determining optimal cut-off levels, and in comparing the performance of multiple tests. For an example of an ROC (receiver operating characteristic) curve, see Figure 17. In the left part of this figure a hypothetical frequency distribution of the test results in patients with and without disease is displayed. Obviously, moving the cut-off value in the direction of lower cell counts will increase the sensitivity (the chance of a positive test in patients with the disease $P(T^+ | D)$), but it will decrease the specificity (the chance of a negative test in those without the disease $P(T^- | \bar{D})$). In the right figure the cumulative distribution $P(T^+ | D)$ is on the Y-axis, and the cumulative distribution $P(T^+ | \bar{D})$ (1 - specificity) is on the X-axis. Generally speaking, combinations of values in the upper left corner of the graph are attractive.

The area under the ROC curve has been proposed as a convenient measure of test performance.^{54,155} The choice of a cut-off point, and of a diagnostic test also depends on the prior probability of disease, preferences for health outcome associated with the test, and with the risks of performing the test. Not the sensitivity and specificity of a test, but its predictive value should be the chief consideration. Hilden gave a realistic example how using the area under the ROC curve may lead to erroneous conclusions about the diagnostic performance of a test. He therefore suggested some modifications: weighing of the X-axis and Y-axis with the prior probability ($P(D)$ and $P(\bar{D})$) and with the utility of treatment (i.e. $U(Treat | T^+, \bar{D})$ and $U(Treat | T^+, D)$). However, a perhaps more sensible way to compare diagnostic or prognostic

tests would be to use likelihood-ratios (see section 2.2), measures of fit of posterior probabilities, and a modified error score, or some measure of the variance of the predicted probabilities, as an indication of the extremeness of the predictions.²¹⁷

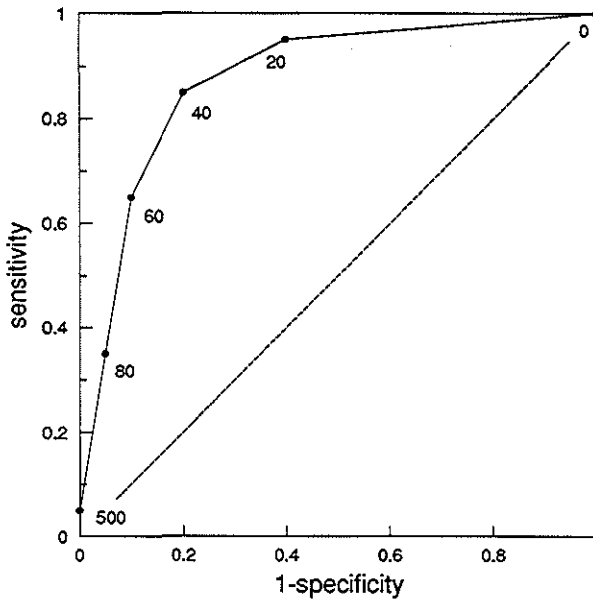

Figure 17. Hypothetical ROC curve. Cumulative distribution of CSF cell count in patients with meningitis and seizure, as a function of 1 - the cumulative distribution of CSF cell count in patients with seizures only. Along the curve, corresponding levels of CSF cell count are given.

Cost-effectiveness analysis

In a cost-effectiveness analysis the same type of calculations is made as in a risk-benefit analysis (see section 2.3), but now one of the two attributes is health-care cost.

Mostly cost is considered from the perspective of society at large, not from the stand-point of the individual patient. For a discussion of the intricacies of measuring health care cost, see Drummond.⁹⁵ Sometimes in a cost-effectiveness analysis QALY's are substituted for the first attribute. These QALY's may stem from evaluation of health services, and from assessments of health status of affected patients, which makes them essentially different from the QALY that is used to approximate preferences for health outcome under conditions of uncertainty,

although the elicitation techniques may be confusingly similar.³⁷³ Preferences for health outcome under conditions of uncertainty do play a role in the "rationing by patient choice" as described recently by Eddy.^{102,103} Of course, when a marginal cost-effectiveness ratio is contemplated, a judgment whether the benefit is worth the cost is still necessary, just as in a risk-benefit analysis, where one has to judge whether the (increased) benefit is worth the risk.⁹⁵

Medical technology assessment comprises a body of methods for the economic evaluation of (new) medical technologies in a broad sense, i.e. including health-benefits, costs, risks and feasibility from a societal point of view.^{143,100} Examples concern breast cancer screening,^{101,384} liver transplantation³⁴ and magnetic resonance imaging for suspected multiple sclerosis.²⁷⁸

Influence diagrams

Influence diagrams are decision support tools that make use of interconnected nodes that represent actions and states of the world, associated with (conditional) probability distributions. Unlike a decision tree, the nodes are not ordered exactly conform the flow of time. The rules of probability theory do apply, however. In Figure 18, the example is displayed in an influence diagram. Influence diagrams combine nicely with the confidence profiles method developed by Eddy, but other ways of specifying conditional distributions are of course allowed.^{336,348}

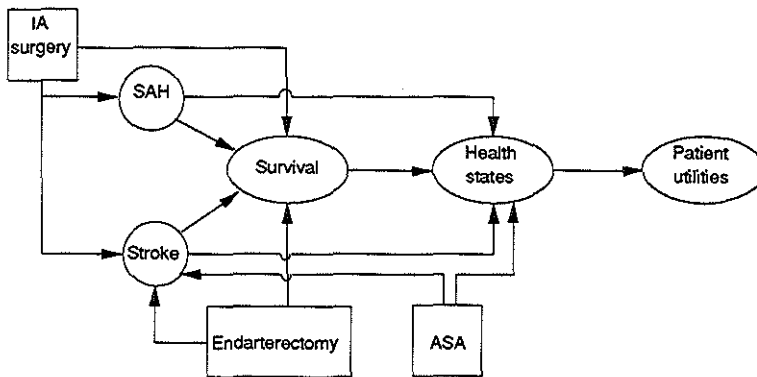

Figure 18. Partially specified influence diagram.

Prospect theory

Even in seemingly simple choice situations people tend not to act or choose according to the principles presented in section 2.3 (connectivity, transitivity and sure thing). Part of these deviations may be caused by framing. For example, an option may seem more attractive when

formulated as a 50% chance of surviving, instead of a 50% chance of dying.³⁸⁰ For decision analysis and the theory of subjective expected utility to be useful for description, a fourth principle was formulated by Kahnemann and Tversky:¹⁹⁹ invariance. Different presentations of the same choice problems yield the same preference, that is, the preference between options should be independent of their description.

In prospect theory, several principles of rational choice are relaxed. Probability weights $\pi(p)$ are introduced, where $\pi(0)=0$, and the function is normalized so that $\pi(1)=1$, but the function is not well behaved near the tail. For low probabilities, $\pi(p)+\pi(1-p)\leq 1$, and $\pi(pr)/\pi(p) < \pi(pqr)/\pi(pq)$, for $\forall 0 < p, q, r \leq 1$. Thus, the function overweighs small and underweighs high probabilities.

The authors also propose a value function v , which is S-shaped, concave above a reference point, and convex below it. A significant property of this function is called loss aversion, i.e. that the response to losses is more extreme than the response to gains. This explains why people tend to demand more (money) for a good they want to keep than they would be willing to pay to obtain it, if they did not possess it. These adaptations offer an explanation for the violations of invariance, and of the sure thing principle in non-transparent choice situations.

Kahnemann and Tversky¹⁹⁹ state that they modified a normative model for descriptive purposes. They never claimed that normative models based on subjective utility theory should thus be adapted and used for prescriptive purposes. Thus, the gap between normative and descriptive, and between normative and prescriptive models remains. The lesson for the latter category of model builders is that they should be careful of framing effects and of using non-transparent utility elicitation methods for assessment of preferences for future health states. This can be accomplished by presenting outcomes as losses and absence of gains simultaneously, and by explicitly presenting outcomes not affected by the decision.

Clinical algorithms

Clinical algorithms are flow diagrams that give a simple management advice. They are especially helpful in emergency settings, for nursing tasks and for educational purposes.^{350,286,259} The algorithm can be based on expert opinion, (formal) consensus, on prediction rules and on decision analysis.^{96,259,286} From the outside it does not always show which method was used to derive the guide-lines. Because a tree structure is sometimes used,³⁵⁰ it may be confused with a decision analysis.

The analytic hierarchy process

In the analytic hierarchy process developed by Saaty^{88,327} a decision problem is decomposed in terms of subgoals. These subgoals are assigned weights, based on strength of preference of the decision maker. These weights are combined into one measure, using matrix algebra. But as there is no relation between risks, probabilities and assigned weights, the results are difficult to interpret.¹⁵⁶ Dolan concluded that the analytic hierarchy method results in "better recom-

recommendations than decision analysis" because his study resulted in stronger (i.e. more extreme) recommendations than the original decision analysis.⁸⁹ Obviously, this argument is not sufficient.⁹⁹

Expert systems

Expert systems are computer programs that make use of formalized knowledge in a way that looks like human inference.³⁹³ The most successful expert systems have a configuration that was basically designed by Shortliffe for MYCIN, an expert system for the selection of the appropriate antibiotic therapy for hospitalized patients. The knowledge base of such an expert system consists of "if ... then ... else rules, with a certainty factor attached. The inference engine combines the production rules that are appropriate to the problem.⁷² The handling of the certainty factors and their interpretation is problematic.^{219,223}

Decision support from expert systems may consist of a simple, straightforward advice. By asking for the production rules that were used for the advice, insight may be improved and the usefulness of additional information can be assessed. Playing "what if" games may also be particularly useful, in order to determine whether additional information should be obtained.

Problems that are suited for an expert-system approach are complex and fuzzy. Preferences for health outcome play a secondary role. Several expert systems (most of them MYCIN-look-alikes) have been described. Examples in the realm of the clinical neurosciences are PLEXUS, an expert system for diagnosis, localisation and prognosis after brachial plexus injury.¹⁹¹ Other systems are MICROSTROKE (stroke type determination),³⁵⁷ and DEMENTIA (differential diagnosis).³¹⁰ None of these systems have been formally evaluated for their diagnostic or prognostic capacities, such as has been described for systems in other clinical domains,²⁹⁹ and should be required from any diagnostic system.^{144,145}

Conclusion

After reviewing the existing methodology for patient-oriented decision support, it seems that clinical decision analysis compares favourably with the other techniques. The theory is - to a certain level - intuitively appealing, and has a firm mathematical foundation. There are practical problems in assessment of preferences for health outcomes, but these will not dissolve by choosing another methodology. In our opinion, when there is a difficult choice between several uncertain diagnostic or therapeutic management alternatives in patient-oriented decision making, clinical decision analysis techniques are called for.

Notes

- a. 'Decision maker' is an abstract entity. He may be represented by the treating physician(s), by the patient, or both.
- b. This statement is an informal expression of odds (o), where $o = p/(1-p) \Leftrightarrow p = 1/(1+(1/o))$.

- c. Using the normal approximation of the binomial distribution, one takes the mean $\mu = p$ and standard deviation $\sigma = \sqrt{p \cdot (1-p)/n}$: 0.011-0.067. As a rule, the normal approximation should only be used when $p \times N > 5$.
- d. The F-statistic approach would lead to an estimated 95% confidence interval of 0.019-0.074.
- e. Except for extreme situations: When a predictor estimates the risk of a certain event at 10^{-6} , and the event occurs, then he can be called poorly calibrated, at least, more poorly than someone who estimated the risk of that event at 0.5.
- f. A rate is an epidemiological term, denoting the number of events divided by the number of patient-years at risk. It is equal to the hazard rate under the assumption of a constant annual risk (an exponential function with proportion surviving (at risk, without event at time t $S_t = e^{-\lambda t}$, where λ is the (hazard) rate, equal to $1/\mu$, the inverse of the expectation of t . For small annual probabilities ($\{p_i = S_i - S_{i+1}\} < 5\%$), p_i equals λ .
- g. Meningitis is a general term for inflammation of the meninges, i.e. the membranes that cover the brain.
- h. The gold standard should be regarded in relation to the purpose of the study. For example, carotid angiography, although not perfect is accepted as a gold standard for the assessment of carotid stenosis, because of the evidence that a relation exists between the degree of stenosis as determined by this procedure, and the effectiveness of carotid endarterectomy. Thus, the choice of a gold standard is in itself a pragmatic one.
- i. This is sometimes referred to as "independent" or "idiot" Bayes, because interdependence of test results is not a consideration.
- j. This approach can be convenient when the attributes are difficult to compare, for example when a diagnostic test is done that causes slight inconvenience, when there is a low probability of serious, but treatable illness. Not only the absolute, but the incremental risks and benefits however, are of interest. Still, an acceptable (incremental) risk-benefit ratio has to be defined anyway, before a decision can be made.
- k. Consider two strategies, A and B, both leading to a one attribute, three level (s_1, s_2, s_3) outcome, where $U(s_1) > U(s_2) > U(s_3)$ with probabilities $P_A(s_1) \geq P_B(s_1)$ and $P_A(s_1 \vee s_2) > P_B(s_1 \vee s_2)$ Under these conditions there is dominance of A over B, and strategy A is always preferred over strategy B.
- l. Because of the link with probability calculus, a scale of 0-1 is preferred. The utility scale has the properties of an interval scale. Transformations of the form $u' = au + b$ are allowed.
- m. However, this would only be a problem when patients would not yet be fully informed of their condition. See also the Discussion (Chapter 11).
- n. In this figure the utilities were adjusted to a scale of 0-1, but in many applications (including those in the following chapters) this is not done when the underlying natural scale consists of life years.
- o. Regret is by some - but not in this study - used with the meaning of utility loss.
- p. In the analysis the mortality and morbidity of clipping are linked by the formula $P(Mb) = 2 \times P(Mt) + 0.02$
- q. This rate was adjusted for life table mortality due to myocardial infarction.

Chapter 3

A review of decision analyses in the clinical neurosciences

Clinical decision analysis is increasingly recognized as a useful scientific tool for the management of individual patients, for the planning of research, and for consensus meetings and development of practice guide-lines.²⁰⁶ Since the publication of the first applications of decision analysis in the early sixties and seventies, the theory has gained wider acceptance. The methodology has now matured, and several interesting applications in the neurosciences that are of practical value to the thoughtful clinician have now been published. The number of papers on neurological subjects is steadily growing. A review of applications in the neurosciences is therefore appropriate, the more so because the studies cover many sub-specialties (neuro-ophthalmology, neuro-oncology, etc.) and some have been published in not-so-well-known journals. In this chapter the results of a systematic search for applications of decision analysis in the neurosciences is presented. This review gives an impression of the area that has been covered by the analyses, their methodology, applicability and their up-to-date-ness.

3.1 Methods

A clinical decision analysis is a study that explicitly addresses the inevitable uncertainties in a clinical problem and combines these with preferences for health outcomes in a consistent framework that obeys the laws of probability calculus and subjective expected utility theory, leading to a management advice for an individual patient, or for a group or type of patients.

Articles dealing with decision analysis (i.e. prescriptive clinical decision making) in the neurosciences were either gathered from one of the recognized bibliographies^{60,206,212,216,396} or from a MEDLINE search, using the search strategy depicted in Figure 19. The Mesh words DECISION THEORY, DECISION TREES, DECISION ANALYSIS and DECISION SUPPORT TECHNIQUES were introduced between 1980 and 1988. Before 1980, articles dealing with (the application of) decision analysis could mostly be found under DECISION MAKING, COMPUTERIZED and BAYES' THEOREM.

Each selected paper contains a decision analysis that results in a clinically relevant management advice. Sometimes the clinical problem can be reduced to one of uncertainty only, and the application of probability theory is sufficient to derive satisfactory solutions. In other instances, it can be shown or it is obvious that preferences for (multi-attributed) health-outcome play a role. Then, either subjective expected utility theory, risk-benefit or cost-effectiveness analysis is used to weigh the diverse outcomes, see also Chapter 2.

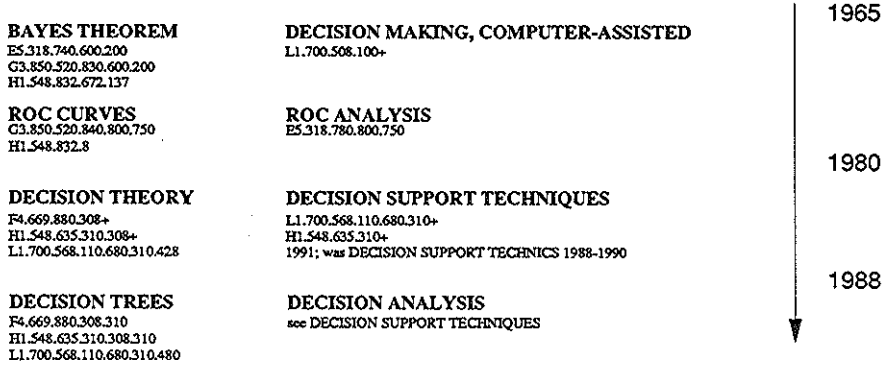

Figure 19. Medline Mesh search strategy.

In this review, only published studies that address problems in the realm of the clinical neurosciences in a clinical or primary care context are considered. Studies analysing mass screening (e.g. spina bifida screening)¹⁵⁰ and prophylaxis (e.g. addition of vitamins to alcoholic beverages)⁵³ are therefore excluded from this review. Publications that concern flow-diagrams and algorithms, based on consensus, expert opinion or prediction rules are not considered. Thus, undoubtedly valuable, decision-oriented papers on diagnosis or prognosis only are excluded from this review. Abstracts, and studies not written in English are also excluded.

All studies are assessed on aspects of clinical applicability. This presumes a clinically relevant case and context description and consideration of all possible strategies, although the tree may be pruned from clinically irrelevant strategies. The explicit use of mathematics is not necessary for easy clinical application, but makes understanding and checking easier. Sometimes the authors have anticipated on the application of the decision analysis on other, slightly different patients, for example by taking into account age and severity of symptoms. This will be called the "extendibility" of the analysis. When the decision analysis makes use of diagnostic or prognostic rules, it is important that the authors have considered transferability to other settings, where the relative incidences of disease may differ considerably. Of course, as clinical knowledge and understanding progresses, the advice from a decision analysis may become outdated, either because new clinical-epidemiological information on diagnosis, prognosis or treatment effects has become available, or because new diagnostic or therapeutic strategies or techniques have emerged.

3.2 Results

The aspects that have been mentioned in the methods section will be summarized in Table 5; each study will be reviewed below.

Arteriovenous malformations

Conservative treatment is recommended as the appropriate management of unruptured arteriovenous malformations (AVM's) by Iansek,¹⁸⁴ who applied principles of decision analysis to this clinical problem. The time span covered in Iansek's analysis does not extend beyond 20 years. This results in an underestimate of the life-time risk of rupture, introducing a bias in favour of conservative management. The authors use a rather high estimate of surgical mortality and morbidity (10% and 27% respectively), which is based directly on series of patients with ruptured AVMs. Again, this is a bias against surgery. Preferences for future life years are not considered. The possibility of incomplete extirpation is ignored. We conclude that this analysis recommends conservative management without good justification, although it provides basic insight into the problem.

Aminoff's analysis^{8,9} is a simplification of the analysis of Iansek.¹⁸⁴ Clinical characteristics of the patients are not described, and age is not a variable in the analysis. Thus, the main clinical considerations are left out of the model. Probability estimates are taken directly from the literature. Duration of survival was not incorporated in the outcome values i.e. mortality and morbidity from haemorrhage was given the same values as mortality and morbidity from surgery, despite the fact that the latter are immediately occurring events. We conclude that this study has simplified the decision problem to such an extent that it is not possible to make meaningful inferences.

Fisher used decision analysis to review the management options for unruptured AVM's. He ignored the possibility of unsuccessful surgery and assumed that a bleeding AVM will never be treated surgically. The author uses average values from the available literature for risks of surgical mortality/morbidity and for mortality and morbidity of haemorrhage. A rather high annual rate of first haemorrhage (2.5% instead of 2.0%) is used. Most of these assumptions introduce a bias in favour of surgery,¹⁰⁸ although the high estimates of surgical risks partly compensate this bias.⁸⁵ Anyhow, one should be careful when drawing conclusions from this analysis.

Auger¹³ described a decision analysis of the management of patients with unruptured arteriovenous malformations, using comparable assumptions as in Chapter 7. However, just as in Fisher¹²¹ the questionable assumption is made that patients attach a lower (0.95) utility value to life with an unruptured AVM before operation, than after successful operation.⁸⁵ Without this assumption, the difference in expected utility between operation and no operation decreases with 1.5 QALY to less than 1 QALY, even for young patients, according to this analysis. None of the studies considered radiosurgery explicitly.

Carotid stenosis

An early study of O'Donnell compares the test accuracy of non-invasive procedures with angiography in the diagnosis of carotid stenosis,²⁸⁵ using ROC analysis. The authors conclude that combinations of - some now obsolete- non-invasive tests (Doppler ultrasound, carotid "phonangiography" and oculoplethysmography) should be used to increase sensitivity. Their informal analysis of risks of angiography and of treatment effects -necessary to compute a cut-off point- lacks the rigour of their data analysis.

Jonas' analysis of intact months of patient survival (IMPS) is not a decision analysis, but merely a crude method to compare the results of endarterectomy trials.^{196,197} However, it provides some insight, in that the trade-off between complications and efficacy of endarterectomy is emphasized.

Matchar's initial analysis of endarterectomy concerned a 55-year old man with verte-bro-basilar transient ischaemic attacks and angina pectoris.²⁵⁵ This quite detailed analysis shows that for the particular patient endarterectomy would improve the quality adjusted life expectancy by only a tiny amount. The authors assume that endarterectomy would reduce the risk of stroke by 50% during 10 years, quite optimistic for a patient with TIA from the posterior circulation. The analysis is extended to a broader group of patients in a separate paper by the same authors.²⁵⁴ They arrive at quite detailed guide-lines for patients with low, intermediate and high risks of stroke, but do not link these advices with patient profiles. Later, the authors analysed non-invasive diagnostic strategies for carotid stenosis, using estimates of test-performance from a thorough review of the clinical literature,¹¹³ combining these with the original analysis. The analysis has been published almost back to back with a position paper from the Health and Public Policy Committee of the American College of Physicians that provides guide-lines for the management of patients with (a)symptomatic carotid stenosis.¹⁶²

Hankey and Warlow¹⁵⁴ combined their own data on the prevalence of mild, moderate and severe symptomatic carotid stenosis with estimates of the sensitivity and specificity of duplex ultrasonography. They aimed at determining the most cost-effective diagnostic strategy, considering health care costs, the occurrence of disabling strokes after angiography, and percentage unnecessary angiographies, the latter depending on the definition of significant stenosis. Prevented strokes or (stroke-free) survival is not considered as an outcome measure.

At the time that these studies were conducted, the results of the major symptomatic carotid endarterectomy trials,^{110,284} that suggest a benefit of endarterectomy for patients with a 70%-99% carotid stenosis, were not yet known. With the publication of the interim results of these carotid surgery trials all previous analyses need to be updated.

Cerebral complications of cardiac disease

Several decision-analytic studies have addressed the decision to prescribe anticoagulants for patients with atrial fibrillation^{25,296} and dilated cardiomyopathy.³⁷⁶ All these studies suggest

that anticoagulants are indicated for most of these patients. However, low-dose coumarines and aspirin^{38,312} are considered only by Naglie²⁸², who concluded that the decision to prescribe anticoagulants was sensitive to plausible changes in estimates of the dis-utility of long-term treatment. Secondary prevention of stroke in (old) patients with atrial fibrillation (who have a higher risk of stroke, but maybe also an higher risk of haemorrhagic complications) has not been studied by decision analysis.³

The study of Kwok²²¹, an analysis of the decision whether or not to implant a pacemaker in an 85-year-old patient with repeated syncope provides useful insight into a diagnostic problem by which a neurologist is also repeatedly confronted. The author complains of lacking data, but does not use his analysis to guide further research. Since the publication of this analysis interesting studies on diagnostic factors in syncope have appeared.²³⁵ This study elegantly illustrates that treatment with an uncertain diagnosis can be more effective from a clinical viewpoint than just ordering another test.

Herpes simplex encephalitis

Two decision analyses of the management of patients with possible herpes simplex encephalitis (HSE) have been published in the early eighties.^{24,43} Management options were then adenine-araboside (Ara-A), brain biopsy or watchful waiting. These analyses have now become outdated because of the advent of acyclovir. It is interesting to compare the quantitative assumptions that were made in these studies, because they are based on the same scientific information. Only in Barza's paper²⁴ the clinical context is described, which makes the assumptions easier to follow. Both authors stress the paucity of data, but Braun emphasized the sensitivity of brain biopsy as the great unknown, whereas Barza thinks that first of all more information about the toxicity of Ara-A is needed. The computed treatment thresholds are not very different (24% and 40%). However, the management advices that are based on these analyses are worded quite differently. Braun⁴³ advises direct treatment with Ara-A, whereas Barza²⁴ suggests that brain biopsy is the best approach in the majority of patients. A problem in interpretation is again that patient profiles are not linked to the risk of suffering from HSE. Braun mentions that brain biopsy has the advantage of diagnosing other treatable disease, such as toxoplasmosis and tuberculosis, but he does not consider this explicitly. Sawyer³³⁵ considers treatment with acyclovir instead of Ara-A. As acyclovir is less toxic and more effective, only the possibility of other treatable causes of encephalitis is a justification for brain biopsy. The analysis suggests that for patients with a low CSF glucose biopsy results in a higher chance of complete recovery, but in patients with unknown or normal CSF glucose, the dilemma whether or not to do a brain biopsy results in a toss-up.²⁰⁷ A systematic analysis of (combinations of) other diagnostic tests than CSF glucose was not carried out. The use of polymerase chain reactions has not been considered.²⁶⁹

Intracranial aneurysms and subarachnoid hemorrhage

Levey²²⁹ reported an analysis of the decision to screen with angiography for occult intracranial aneurysms in patients with polycystic kidney disease. A rather high (2%) annual risks of rupture, but a low risk of grave complications from subarachnoid aneurysmal haemorrhage (37%) was assumed. Parameters that appeared crucial to the results of the analysis were the prevalence of intracranial aneurysms in this group of patients (estimated from autopsy studies at 30%(9%-30%), and surgical risks. According to this analysis the benefit of screening amounted to 1.2 years (2.5% of the total life expectancy) for patients aged 20, decreasing to almost zero for patients aged 70. The authors conclude that the benefit of screening is so small that it cannot be recommended.

Interestingly, Chapman⁵⁹ reported a study of 88 patients with polycystic kidney disease, of whom 60 underwent high resolution contrast enhanced CT scanning, 21 angiography, and 11 both procedures. In four patients, aneurysms were discovered, for a prevalence of 4%, considerably lower than the estimate in Levey's study.²²⁹ However, many aneurysms may have remained undetected, which is also suggested by the low yield from CT (2 aneurysms in 60 patients) as compared to angiography (2 aneurysms in 32 patients). The authors defended the choice of CT scanning as the primary investigation by referring to the risk of complications from angiography, a factor that has been proven by Levey²²⁹ to be of minor importance to the decision to screen. Moreover, the authors pose the unsustainable conclusion that screening every 5-10 years for occult aneurysms is justified for all patients with polycystic kidney disease, totally neglecting the results of the decision analysis. In an accompanying editorial this study has raised some critical comments.⁴⁰⁴

Van Crevel³⁸² described a decision analysis of the management of a 45-year old hypothetical female patient, in whom an 8 mm left middle cerebral artery aneurysm was found by angiography. The risk of aneurysm rupture and its consequences was compared with the risk of elective surgery, using discounted quality adjusted life expectancy. The authors give recommendations for the management of similar patients of other age, with other surgical risks. This analysis forms the basis of several other decision analytic studies (see also Chapters 4,5 and 6).^{365,367,86}

Auger¹³ reported a decision analysis of the management of unruptured intracranial aneurysms that is quite similar to our studies (Chapter 4 and Chapter 5). However, no surgical mortality was assumed, the risk of aneurysm rupture was estimated at an annual rate of 4%. This estimate is based on one personal series⁴⁰² and disregards the other evidence,^{189,198} that suggests a lower rate of approximately 1%⁸⁴ see also Chapter 2. Life with an unruptured untreated aneurysm is valued at 0.975 of a life in full normal health, an assumption that is

already discussed previously. The value of years of survival in the near is the same as in the distant future. These questionable assumptions favour surgery, but they are not extensively studied by a sensitivity analysis.

Van der Meulen³⁸⁵ used decision analysis to investigate whether cerebral angiography is indicated in patients with clinically definite infective endocarditis, in order to detect mycotic aneurysms before rupture occurs. The authors conclude that for most patients angiography decreases the survival probabilities, because surgical treatment of a detected mycotic aneurysm is more harmful than medical treatment only.

McNutt²⁶³ described a decision analysis of the management of a 87-year-old woman with aneurysmal subarachnoid hemorrhage, who suffered a subendothelial myocardial infarction on the fourth day after admission. Five strategies are compared, operate immediately, after one, two or three weeks, or never operate, balancing the increased risks of surgery against the risk of rebleeding, using a time horizon of four weeks. No specific assumptions are made about the other factors affecting prognosis, such as delayed cerebral ischemia, hydrocephalus and mortality from other causes, but this may be regarded appropriate here, according to the 'sure thing principle' (see Chapter 2, section 2.3). It was concluded that as the opportunity for immediate surgery (the best choice according to the analysis) has already passed, never operate was the preferred option. Tranexamic acid however, was not considered.

Fleming¹²³ used decision analysis to explore possible management options in a 34-year-old woman who awoke four days after delivery of a healthy baby girl with a bi-occipital headache, had a grand mal seizure, and experienced complete loss of vision when she regained consciousness. A computed tomographic scan of the head showed no blood, but a cisternal tap revealed bloody liquor. Spectrophotometry was not performed, but might have taken away the suspicion of subarachnoid hemorrhage. Other conditions were deemed unlikely. Four-vessel angiography was carried out, but the procedure was aborted because of transient ischemia, in the territory of the left middle cerebral artery. In the analysis a strategy of watchful waiting was compared with angiography for detection of an intracranial aneurysm, on the basis of quality adjusted life expectancy. Fear of repeat angiography was explicitly considered in the analysis, quantified as the amount of life expectancy the patient would be willing to forgo to avoid angiography. The probability of aneurysmal subarachnoid hemorrhage as the cause of the patient's complaints was taken at 5%. The possibility of finding an asymptomatic aneurysm on angiography (population prevalence for a patient of this age: 0.5%-2%), leading to wrong conclusions about the risk of haemorrhage, was not considered.

Multiple sclerosis

Hische¹⁷⁹ used logistic discriminant analysis to estimate a likelihood ratio as continuous function of the IgG index from a sample of patients with multiple sclerosis and a group of

patients with diseases that are likely to cause problems in differential diagnosis. The gold standard for the diagnosis of multiple sclerosis is based on clinical criteria only,³²¹ instead of prolonged observation. An easy-to-use nomogram is presented that relates the prior probability of multiple sclerosis and the IgG index to a posterior probability.

Iansek¹⁸⁴ and Kempster²⁰⁹ assessed the diagnostic impact of visual evoked responses and CSF analysis on the management of patients with one spinal lesion. They conclude that in certain cases CSF analysis and myelography can be omitted in favour of a policy of follow-up, but they only analyze diagnostic probabilities and not the (dis-)utility of erroneous diagnosis. Magnetic resonance imaging (MRI) is not considered. An earlier study of the same group describes the diagnostic behaviour of trained neurologists and residents in a case of possible multiple sclerosis.¹⁸

Moony's²⁷⁸ cost-effectiveness analysis of the use of MRI in suspected multiple sclerosis was meant to set priorities for technology assessment research in multiple sclerosis. The authors conclude from their analysis that study of the test characteristics of MRI, but most of all of the effects of resolving uncertainty in the diagnosis on well-being in patients with suspected multiple sclerosis is most welcome. However, the authors assumed a quality-adjustment factor of 0.8 for the time spent 'labelled multiple sclerosis, without further symptoms' which is difficult to relate to patients' preferences for health outcomes under conditions of uncertainty.

The study of Mushlin²⁸⁰ is a rigorous ROC analysis of the accuracy of MRI in the diagnosis of multiple sclerosis. Management alternatives, i.e. no diagnostic imaging, contrast enhanced CT, and other diagnostic entities are only mentioned in the discussion, but not extensively so, and a case and context description is not provided. Therefore, this study is not further included in this review.

Temporal arteritis

Several studies have tackled the problem of prescribing prednisone or doing a biopsy in suspected temporal arteritis. Elliot's decision analysis¹⁰⁷ does not present a typical patient and does not describe the clinical setting, which makes its clinical applicability limited. Moreover, only monetary costs are used as an outcome measure, and not patients' preferences, which further hampers its usefulness in a clinical setting. Two large series of patients with temporal arteritis became available after the publication of this analysis.^{163,325} They were included in the analysis of Nadeau²⁸¹, whose study does not suffer from the problems mentioned above. However, questionable utility assumptions were made (i.e. that the utility loss from steroid complications is valued twice the utility loss from untreated temporal arteritis, without specifying a basis for this crucial assumption. The strategy "no treatment, no biopsy" is not formally evaluated. Chang's analysis compares risk-benefit ratios of the management of patients with

polymyalgia rheumatica and suspected arteritis temporalis.⁵⁸ The study is up to date and recommends that patients without signs of cranial arteritic symptoms should not be given steroids.

Other neurologic conditions

Acosta² analysed diagnostic strategies using CT, angiography and perimetry in patients with unexplained loss of vision, in order to distinguish hemianopsia from monocular blindness. According to the analysis, the most cost-effective strategy consists of performing (repeated) perimetry, until progressive blindness or hemianopsia develops. In the analysis individual patient characteristics are not included, nor is the context or clinical setting described.

Balla¹⁷ proposed an algorithm in which asymptomatic patients with head-injury should undergo skull x-ray, and only undergo CT-scanning of the brain when a fracture is visible. The author estimates that 3% of the patients with a skull fracture have an intracranial haematoma (ICH), and that for every patient with ICH thus detected 1400-1650 skull x-rays and 40 CT scans will be necessary. Whether this suggested approach can be called "cost-effective" depends on the mortality and morbidity that is averted. But this has not been estimated.

Bardy²² used Bayes' theorem to compute the probability of finding a mass lesion in patients who present with a first seizure. Several diagnostic factors such as age of the patient and family history were not considered. No utility assumptions were made.

Carrera⁵⁰ estimated the cost of finding cases with treatable disease by computed tomography among patients with headache or temporal lobe epilepsy and a normal neurological examination. They do not go beyond this rather crude analysis by -for example- considering the utility of false-negative and false-positive examinations, or the benefit of treatment.

The group of Bolhuis³³ and Defesche⁷⁸ used Bayes' theorem in the differential diagnosis of (autosomal recessive) spinal muscular atrophy and (X-linked recessive) Becker muscular dystrophy. They elegantly showed how probabilistic information changed the intuitive conclusions about the most likely diagnosis, which had profound implications, because a pregnant sister of the patient under consideration needed genetic counselling. Assessment of dystrophin or the dystrophin gene was not considered.

Eckman⁹⁸ considered the prophylactic treatment with chemotherapy in a 47-year-old man with Eaton-Lambert syndrome and a negative CT-thorax and bronchoscopy. They concluded that, given the available data on the risk of developing small cell lung cancer, and the effectiveness and toxicity of therapy, a waiting strategy is better for all presumable likelihoods of cancer.

Joffe¹⁹⁴ used logistic discriminant analysis in series of children with convulsions and fever, to find diagnostic factors indicative of meningitis. Selecting children with either an abnormal neurologic examination or a focal seizure, or a previous visit to a physician (!) resulted in 100% sensitivity with a low specificity (62%). The authors conclude that children without any of these

signs can do without an LP. However, no independent validation of the study results was obtained. Although the study was aimed at finding ways to make the lumbar puncture unnecessary, a formal comparison between the risks and discomfort associated with LP, and its benefits was not made. In a more recent retrospective analysis Offringa²⁸⁶ arrived at similar conclusions.

Kent's study²¹⁰ is an ROC analysis of reported study results on the diagnostic accuracy of MRI, CT and myelography in the diagnosis of spinal lumbar stenosis. No definite management advice could be given, as the authors considered virtually all studies inconclusive, mostly because of methodological shortcomings.

Levin²³⁰ analysed the diagnostic management of optic nerve tumours with MRI and CT in children using Bayes' theorem, and suggests an approach that is based on clinical information and CT scanning. Tables with prior probabilities of meningeoma, glioma, and the predictive value of clinical and radiographic diagnostic tests are presented.

Liang²³¹ computed the amount of radiation used and the cost in dollars per day of suffering averted when ordering x-rays for patients with acute low back pain in a primary care setting. He concludes that for patients who have a normal physical and neurological examination, the risks and costs of ordering roentgenograms do not seem to justify the relatively small benefit.

Magid's²⁴⁷ cost-effectiveness analysis of prevention of Lyme disease after tick bites considered prophylactic treatment or careful follow-up, c.q. serologic testing. The costs and risks of treatment are low. The analysis suggests that patients with a risk of infection exceeding 3.6% should receive prophylaxis, and when this risk is lower than 1%, treatment is not necessary. The authors discuss the problem of estimating the risk of infection in a patient with a tick-bite, but they do not summarize their recommendations in this regard. A randomized trial of prophylactic treatment after tick bite against placebo yielded non-conclusive results. These two studies are complementary, as the risk of infection was very low (1.2%) in the placebo treated group.³⁴²

McNeil²⁶¹ illustrated how cost-effectiveness calculations help in deciding about the use of laboratory testing (the radiobromide-partition test)^b and more effective treatment (rifampicin) for possible tuberculous meningitis in developing countries.

Schipper²³⁸ showed that the diagnostic performance of CT and myelography for detection of lumbar herniated disk is comparable, and argues that CT should be the investigation of first choice, because of its non-invasiveness.

Simon³⁴⁴ analysed the cost-effectiveness of CT investigation of demented patients, and concludes that the cost-effectiveness of CT, but not of MRI compares favourably with other health-care interventions. Unfortunately the author does not adjust the crude prior probability of treatable lesions for the many assumptions about his patient in his analysis.

Wiesel⁴⁰⁵ compared routine treatment with intramuscular penicillin to LP and intravenous penicillin in patients with latent syphilis. The latter strategy increases the estimated cure rate from 99.7% to 99.9%, at the expense of 0.3% mostly transient complications. The author does not go beyond a comparison of these risks, although he suggests that on the basis of these results CSF examination in asymptomatic late syphilis can be done without.

Zarin⁴¹⁸ computed in an elegant analysis the risk-benefit ratio of initiating lithium therapy after a first or second attack of manic-depressive disorder. Outcomes are expressed in time on lithium per attack avoided. Carbamazepine and other (less toxic) treatment modalities^{127,134} were not considered.

A review of decision analyses in the clinical neurosciences

Table 5. Decision analyses in the clinical neurosciences. Legend: TY: type of analysis (RI = risk analysis, RB = risk-benefit analysis, RO = ROC analysis, CE = cost-effectiveness or cost-benefit analysis, U = utility analysis); CA: case description; CX: context description; CL: completeness; EX: extendibility; UD: up-to-date-ness (T= new technology, E = new evidence).

Author	Year	Ref.	Condition	Strategies	TY	CA	CX	CL	E	UD
Acosta	1981	2	Sudden blindness	CT; angiography; perimetry	CE	N	N	N	-	Y
Aminoff	1985	8,9	Arteriovenous malformation	Surgery or not	U	N	Y	Y	-	T/E
Auger	1992	13	Arteriovenous malformation	Surgery or not	U	N	Y	Y	Y	Y
Auger	1991	13	Intracranial aneurysm	Surgery or not	U	N	Y	Y	Y	T
Balla	1984	17	Head injury	Skull x-ray or not	R	N	Y	Y	Y	Y
Bardy	1991	22	First seizure	CT or not	R	N	N	N	-	E
Barza	1980	24	Herpes encephalitis	Biopsy; Ara-A; no treatment	R	Y	Y	Y	Y	T/E
Beck	1981	25	Atrial fibrillation	Anticoagulation or not	U	Y	Y	Y	Y	Y
Bolhuis	1987	33,78	Hered. neuromuscular disease	Genetic counselling	R	Y	Y	Y	N	T
Braun	1980	43	Herpes encephalitis	Biopsy; Ara-A; no treatment	R	N	N	Y	Y	T
Carrera	1977	50	Temporal lobe epilepsy	CT or not	CE	N	Y	N	-	Y
Chang	1983	58	Arteritis temporalis	Biopsy; corticosteroids, no treatment	RB	N	Y	Y	Y	Y
Dippel	1992	86,367	Intracranial aneurysm	Angiography or not	U	Y	Y	Y	Y	Y
Eckman	1986	98	Eaton-Lambert syndrome	Prophylactic chemotherapy or not	U	Y	Y	Y	Y	Y
Elliot	1983	107	Arteritis temporalis	Biopsy; corticosteroids; no treatment	CE	N	N	Y	-	Y
Fisher	1989	121	Arteriovenous malformation	Surgery or not	U	N	Y	Y	N	T/E

Chapter 3

Table 4. (Continued).

Author	Year	Ref.	Condition	Strategies	TY	CA	CX	CL	E	UD
Fleming	1988	123	Subarachnoid haemorrhage	Angiography or not	U	Y	Y	Y	N	E
Hankey	1990	154	Carotid stenosis	Duplex; auscultation; angiography	CE	N	Y	Y	N	E
Iansek	1983	185	Arteriovenous malformation	Surgery or not	R	N	Y	Y	N	T
Iansek	1985	184,209	Multiple sclerosis	Myelography or not	U	Y	Y	Y	N	T
Joffe	1983	194	Febrile seizures	Lumbar puncture or not	R	N	Y	Y	N	E
Kent	1992	210	Lumbar spinal stenosis	MRI, CT, myelography	RO	N	Y	Y	N	Y
Kwoh	1984	221	Syncope	Pacemaker or not	CE	Y	Y	Y	Y	Y
Levey	1983	229	Intracranial aneurysm	Angiography or not	U	N	Y	Y	Y	Y
Levin	1991	230	Optic nerve tumour	MRI; CT	R	N	Y	N	N	Y
Liang	1982	231	Low back pain	Lumbosacral x-ray or not	RB	N	Y	Y	Y	Y
Magid	1992	247	Lyme disease	Prophylaxis after tick bite or not	CE	Y	Y	Y	Y	Y
Matchar	1988	113	Carotid stenosis	Non-invasive testing	U	Y	Y	Y	Y	E
Matchar	1986	254,255	Carotid stenosis	Endarterectomy or not	U	N	Y	Y	Y	E
McNeil	1980	261	Tuberculous meningitis	Clinical assessment vs bromide test	CE	N	Y	N	-	Y
McNutt	1987	263	Subarachnoid haemorrhage	Surgery or not	R	Y	Y	N	N	Y

Table 4. (Continued).

Author	Year	Ref.	Condition	Strategies	TY	CA	CX	CL	E	UD
Moony	1990	278	Multiple sclerosis	MRI or not	CE	N	Y	Y	Y	Y
Nadeau	1988	281	Arteritis temporalis	Biopsy; corticosteroids	U	N	Y	N	Y	Y
Naglie	1992	282	Atrial fibrillation	Warfarin; aspirin; no treatment	U	N	Y	Y	Y	Y
O'Donnel	1980	285	Carotid stenosis	Non-invasive testing	RO	N	Y	Y	N	E
Offringa	1992	286	Febrile seizures	lumbar puncture or not	R	N	Y	Y	N	Y
Pauker	1986	296	Atrial fibrillation	Anticoagulation or not	U	N	Y	Y	N	Y
Sawyer	1988	335	Herpes encephalitis	Biopsy; Ara-A; Acyclovir; no treatment	R	Y	Y	Y	Y	E
Schipper	1987	338	Lumbar herniated disk	CT; myelography; both	R	N	Y	Y	-	T
Simon	1985	344	Dementia	CT; magnetic resonance imaging; none	CE	N	Y	N	N	Y
Ter Berg	1992	366	Arteriovenous malformation	Surgery or not	U	Y	Y	Y	Y	Y
Ter Berg	1988	365	Intracranial aneurysm	Surgery or not	U	Y	Y	Y	Y	Y
Tsevat	1989	376	Dilated cardiomyopathy	Anticoagulation or not	U	N	Y	Y	Y	Y
Van Crevel	1986	382	Intracranial aneurysm	Surgery or not	U	Y	Y	Y	Y	Y
Van der Meulen	1992	385	Mycotic aneurysm	Angiography or not	R	Y	Y	Y	Y	Y
Wiesel	1985	405	Asymptomatic late syphilis	Lumbar puncture or not	R	N	Y	Y	Y	Y
Zarin	1987	418	Manic-depressive disorder	Lithium therapy or not	RB	N	Y	Y	Y	Y

3.3 Discussion

Forty-seven decision analyses of 28 different management problems in the clinical neurosciences were identified. Figure 20 shows how the number of decision-analytical applications in neurology is steadily growing. Nineteen analyses employed the theory of subjective expected utility, nine used cost-effectiveness analysis, two used ROC analysis, and seventeen studies were risk-, or risk-benefit analyses.

The decision analyses were analyzed on aspects of clinical applicability. Twenty-seven analyses lacked a case-description, and four studies did not even disclose a context, although they were supposed to give specific advice about medical management. Obviously, this poses a constraint on applicability. Confusion about the application of a decision analysis can often be avoided with a descriptive branch that precedes the first node in the tree and provides a clinically relevant context and case description. This branch serves as a reminder that the results of a decision analysis should be applied to individual patients.

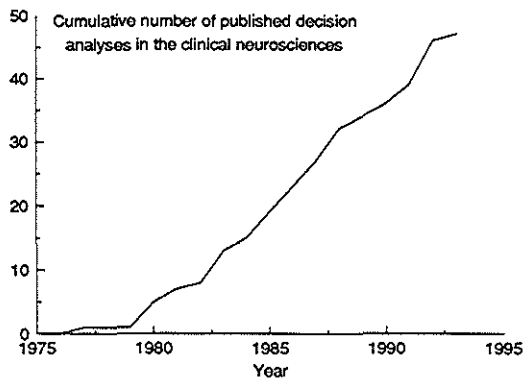

Figure 20. Published decision analyses in the clinical neurosciences.

Extendibility is more than a graph of prior probabilities with delineation of test and treatment thresholds. In eighteen studies the authors had not advised the reader at all how to extend the results of the analysis to patients with (slightly) different clinical profiles. Progress in clinical research is fast. It is sometimes a matter of years before an analysis becomes outdated, either because new technology has been developed and introduced, or because new knowledge of prognosis, diagnosis and treatment effects has been produced. Seventeen studies at last were clearly not up-to-date, because of these reasons. These studies concern ten clinical problems (arteriovenous malformations, febrile seizures, subarachnoid haemorrhage, herpes encephalitis, lumbar spinal stenosis, hereditary neuromuscular disease, carotid stenosis,

multiple sclerosis, herniated disk and manic-depressive disorder). A new, updated analysis by different authors has been published for the first four conditions, and in the case of multiple sclerosis ("singular spinal sclerosis")¹⁸⁴ a decision analysis (but not a cost-effectiveness analysis!) has been made superfluous by the availability of MRI.

Several studies only applied Bayes' theorem on estimates of prior probabilities and test characteristics, derived from the literature, although many additional assumptions were necessary before a management advice could be given. In several studies the explicit consideration of patients' preferences would have improved the recommendations. The role of secondary uncertainty was unclear in many analyses. Sensitivity analyses, let alone probabilistic sensitivity analysis was not used. Clearly, there is room for improvement.

Decision analysis is a tool to generate useful advice in complex clinical decision situations, when there are several identifiable management options, with high risks. Carrying out a decision analysis requires time, a clear mind and expert knowledge of the clinical domain. The decision analyst should have knowledge of decision-analytic techniques, and should feel comfortable in the area of clinical epidemiology and biostatistics. The availability of adequate computer resources and a database of the clinical literature is almost obligatory.

Although a large spectrum of diseases in clinical neurology has been covered by the analyses discussed here, the group of heredo-degenerative disease has apparently not drawn much attention, perhaps because of the lack of therapeutic possibilities. However, difficult diagnostic decisions with implications for genetic counselling have to be made in this area. Other areas that would benefit from decision-analytic research effort include in our opinion: management of cervical spondylotic myelopathy, perhaps in combination with a randomized clinical trial of surgical treatment,³²⁶ the diagnostic management of patients with progressive polyneuropathy and the diagnostic and therapeutic management of patients with lumbar spinal stenosis.

From the 51 classic dilemmas in the clinical neurosciences compiled by Warlow and Garfield^{394,395} more than half cannot be solved by just carrying out a large randomized trial, either because individual variability is large, and the disease in question comparatively rare, or because a very long-term follow-up would be required to obtain valid results. Only a few of these have been adequately addressed by decision analysis. Evidently, there is still a lot of work to do.

Notes

a. Koudstaal PJ. *Personal communication*. 1993.

b. *The radiobromide-partition test measures the distribution between serum and CSF of intravenously injected*

⁸²Br. It has a sensitivity of approximately 90% and a specificity of 85%, when a cut-off ratio of 1.6 is used.

Chapter 4

Transient ischaemic attacks, carotid stenosis and an intracranial aneurysm^a

Carotid angiography for transient ischaemic attacks may reveal an unruptured aneurysm of the circle of Willis. This is not surprising, because the prevalence of unruptured aneurysms in these patients is at least 0.5%, but probably several times higher.^{258,412} The combination of an unruptured aneurysm and a stenotic or ulcerating symptomatic carotid lesion causes a management problem that will be analyzed using decision theory. There are two surgical options: aneurysm surgery and endarterectomy. These can be combined into 4 strategies, each with its own benefits and risks:

- 1) Wait (no carotid endarterectomy and no clipping of the aneurysm).
- 2) Aneurysm surgery, to prevent subarachnoid haemorrhage (and -in some cases- to prevent stroke as well).
- 3) Carotid endarterectomy, to prevent stroke.
- 4) Carotid endarterectomy and aneurysm surgery to prevent both stroke and subarachnoid haemorrhage.

Each of the strategies can be combined with acetyl-salicylic acid (ASA), making the total number eight.

Surgery of unruptured aneurysms and endarterectomy for symptomatic carotid artery disease have been the subject of previous decision analyses.^{254,362} In the unruptured aneurysm problem, the decision for surgery depends mostly on the cumulative risk of rupture (and therefore, on the age of the patient) and on the surgical risks. For endarterectomy a similar trade-off between surgical and long-term risks can be made. Until recently, a beneficial effect of endarterectomy for patients with a symptomatic carotid lesion was not established. The preliminary results of two large randomized trials indicate a beneficial effect of endarterectomy, but only for patients with a stenosis of 70% or more.^{110,116,220,284} For the patients in the present analysis the benefits of both procedures are reduced, because the life-expectancy is shorter as a result of co-existing disease. Furthermore, endarterectomy is not indicated when the TIA's are caused by thrombo-embolism from the aneurysm, making clipping doubly effective because both the risk of stroke and SAH will be reduced. At last, even the prescription of acetyl-salicylic acid (ASA) needs careful consideration, as it may lead to more severe complications from SAH.

4.1 Patients and methods

Patients

Three patients with the above mentioned combination of lesions will be discussed, all from the neurological department of the Dijkzigt Hospital in Rotterdam. The clinical characteristics of the patients are summarized in Table 6. The first patient will be used as a "key-patient" to illustrate our analysis. This 63-year-old man had an attack of transient blurring of vision of the right eye, four weeks before admission. Apart from complaints of dysbasia he was in excellent condition. Neurological examination was unremarkable. Blood pressure was 170/80, ECG, chest X-ray, routine blood samples and computed tomography of the brain showed no abnormalities. Four-vessel cerebral angiography revealed a 50% stenosis of the right internal carotid artery at the bifurcation and a 4 mm aneurysm of the right middle cerebral artery. Amaurosis fugax cannot be explained by an aneurysm of the middle cerebral artery, but in patient 2, and less so in patient 3 thrombo-embolism from the aneurysm as well as from the carotid lesion may have caused the TIA's.³¹³

Table 6. Clinical characteristics of the three patients.

	Key-patient	Patient 2	Patient 3
Patient			
Age	63	58	69
Sex	male	male	male
Carotid lesion			
Location	right bifurcation	left bifurcation	right ICA
Degree	50% stenosis	ulcerating plaque	50% stenosis
Aneurysm			
Location	right MCA	left MCA	right PCoA
Size	4 mm	10 mm	5 mm
TIA			
Symptoms	amaurosis fugax	hemi-paresthesias	hemiparesis
Likelihood that the IA caused the TIA	0%	50% (25-75%)	25% (5%-50%)

Decision analysis

Decision analysis consists of identification of the available management strategies, determination of the possible events and health states resulting from each strategy and quantification of the likelihood of these events and health states. Then follows for each strategy the computation of the survival distribution and the life expectancy in each health state. The life expectancy can be adjusted for quality of life, and for time preferences by discounting future life years. The strategy with the highest life expectancy should be considered as good advice. Sensitivity analyses are used to examine the influence of plausible changes in each estimate on the life expectancy of each strategy and to examine the simultaneous effect of the uncertainty in all estimates in a full Bayesian analysis,^{142,216,396} see also the results section.

The basic assumptions may be illustrated by a decision tree, see Figure 21. The choice between 'Wait', 'Aneurysm surgery', 'Endarterectomy' or both 'Aneurysm surgery and endarterectomy' is represented in this tree. The second choice, the prescription of acetyl-salicylic acid (ASA) is not represented in the tree, in order to avoid unnecessary duplication.

Transient ischaemic attacks, carotid stenosis and an intracranial aneurysm

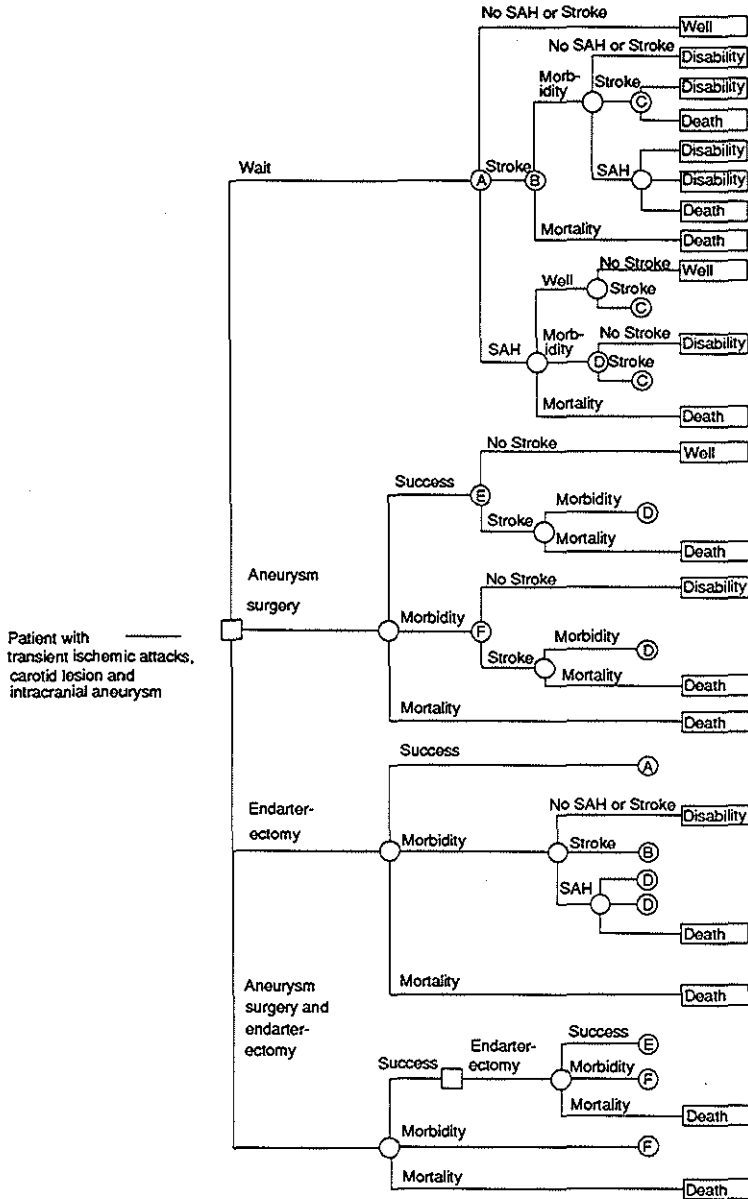

Legend to Figure 21. Decision tree for the management of patients with TIA's and an unruptured intracranial aneurysm. Schematic representation of strategies: 'Wait', 'Aneurysm surgery', 'Endarterectomy' and 'Aneurysm surgery and endarterectomy'. All strategies can be combined with ASA. Squares: decision nodes, circles: chance nodes, rectangles: outcome nodes. Upper case letters (A-F) refer to identical subtrees.

When the strategy 'Wait' is chosen, the patient may suffer a subarachnoid haemorrhage (SAH) that results in death, severe disability or recovery, or a stroke may occur, resulting in death or disability (minor strokes and TIA's are not considered). The occurrence of at most two events (two strokes, or a stroke and SAH) is modelled in the tree. It is assumed that after a non-fatal subarachnoid haemorrhage the aneurysm will be clipped, completely preventing rebleeding. In order to simplify the tree for presentation, branches representing events occurring after one, two, three and more years have been combined into one single branch.

'Aneurysm surgery' may result in peri-operative mortality or serious morbidity. After successful clipping, SAH is completely prevented. If the TIA's are caused by thrombo-embolism from the aneurysm, clipping will prevent stroke as well. After a non-fatal outcome of surgery, ASA can be prescribed. ASA reduces the incidence of disabling strokes and vascular death (fatal myocardial infarction and stroke),^{11,49,292} but it may increase the risk of complications from SAH. The structure of the subtrees with and without ASA is identical but the probability values used in the analysis differ.

'Endarterectomy' carries a risk of mortality and permanent morbidity. After a successful procedure, the risk of stroke is reduced. The combined procedure - aneurysm surgery and endarterectomy - is carried out in two stages, without appreciable delay. When aneurysm surgery results in permanent morbidity, no endarterectomy will follow.

4.2 Available data and estimates

Based on a review of the literature, best guesses for the parameters in the decision tree are made. Because of the uncertainty from lack of knowledge and variability, ranges of values will be suggested. The estimates will be summarized in Table 7.

Table 7. Estimated probabilities for the decision analysis of a symptomatic carotid lesion and an unruptured IA. For sources see text.

	Key patient	Patient 2	Patient 3
Stroke and myocardial Infarction			
Annual rate of major non-fatal stroke	3% (2%-4%)	1% (0.5%-2%)	3% (2%-4%)
Annual rate of fatal stroke	1.5% (1%-2%)	0.5% (0.25%-1%)	1.5% (1%-2%)
Annual rate of fatal myocardial infarction	3% (2%-4%)	2% (1%-3%)	3% (2%-4%)
Endarterectomy			
Mortality	2% (1%-4%)	2% (1% - 4%)	2% (1%-4%)
Morbidity	4% (2%-8%)	4% (2% - 8%)	4% (2%-8%)
Efficacy	50% (25%-75%)	10% (5% -20%)	50% (25%-75%)
Subarachnoid haemorrhage			
Annual rate	1% (0.5%-2%)	1.25% (.5%-2.5%)	1% (0.5%-2%)
Mortality	55% (50%-60%)	55% (50% -60%)	55% (50%-60%)
Morbidity	15% (10%-20%)	15% (10%-20%)	15% (10%-20%)
Aneurysm surgery			
Mortality	2% (1%-4%)	3% (1.5%-6%)	1% (0.5%-2%)
Morbidity	8% (6%-12%)	15% (12%-21%)	4% (3%-6%)
ASA			
Efficacy (vascular death)	15% (10%-20%)	15% (10%-20%)	15% (10%-20%)
Efficacy (non-fatal stroke)	30% (20%-40%)	30% (20%-40%)	30% (20%-40%)
Increase in SAH mortality and morbidity	5% (1%-10%)	5% (1%-10%)	5% (1%-10%)

Subarachnoid haemorrhage

The annual rate of rupture of an incidental aneurysm, has been estimated at approximately 1%.^{164,189,306,382,409} Rosenorn³²³ suggested a rate of 2% after comparing the prevalence of IA's and incidence of SAH, but this is an overestimation in our opinion, because the IA prevalence was not adjusted for age. The size of the aneurysm may be related to the risk of rupture.^{112,198,201,402} Therefore, the annual rate of rupture is taken at 1.25% (.5-2.5%) for patient 2.

Long-term analgesics use has been suggested as a risk factor for rupture of intracranial aneurysms in a matched case-control study of risk factors for presence of IA's.⁷⁶ This study was not designed to investigate risk factors for rupture of IA's, and there was no control for possible confounders.²⁷³ Thus, we assume that the risk of aneurysm rupture is not increased by ASA.

The mortality associated with SAH is taken at 55% (50%-60%) and the risk of irreversible, serious disability at 15% (10%-20%). Complete recovery is expected in 30%.^{7,169,306,401} When the patient is treated with ASA, we estimate that 5% (1%-10%) should be added to the risk of morbidity and mortality after SAH.

Aneurysm surgery

There are only few data available on the surgical mortality and morbidity associated with the clipping of an intact aneurysm. Very low mortality rates (0-2%) were reported in a few small series.^{165,330,332,413} Because of their size, these studies do not allow detailed study of specific risk factors for surgical mortality and morbidity. Therefore, expert opinion was used to assess surgical risks in the three patients, see Table 8. Apart from surgical skill and the condition of the patient, the rate of surgical complications will depend on shape, size and location of the aneurysm. The extent of the carotid lesion was felt to be of minor importance. Again, a wide range of plausible values is assumed.

Table 8. Results of the decision analysis of a symptomatic carotid lesion and an unruptured IA. Highest values for each patient and outcome measure are underlined.

Patients and strategies	Life expectancy			
	unadjusted	discounted	quality adjusted	discounted and quality adjusted
Patient 1				
Wait	10.50	7.69	10.07	<u>7.44</u>
Aneurysm surgery	<u>10.77</u>	<u>7.81</u>	<u>10.17</u>	<u>7.44</u>
Endarterectomy	10.40	7.60	9.89	7.28
Endarterectomy and IA surgery	10.65	7.72	9.98	7.28
Patient 2				
Wait	14.31	9.61	13.99	9.44
Aneurysm surgery	<u>15.28</u>	<u>10.02</u>	<u>14.57</u>	<u>9.57</u>
Endarterectomy	14.02	9.40	13.53	9.12
Endarterectomy and IA surgery	14.96	9.81	14.11	9.27
Patient 3				
Wait	8.40	6.54	8.12	6.35
Aneurysm surgery	<u>8.82</u>	<u>6.79</u>	<u>8.52</u>	<u>6.59</u>
Endarterectomy	8.26	6.42	7.89	6.16
Endarterectomy and IA surgery	8.66	6.66	8.28	6.39

Stroke and myocardial infarction

The annual rate of a major stroke in untreated patients with unilateral symptomatic moderate carotid stenosis (like patients 1 and 3) has been estimated at 4.5% (3%-6%).^{49,110,220,284} We estimated the mortality from a major stroke at 33%, morbidity at 67%.^{114,115,116,351,400} In patients with threatening stroke myocardial infarction is a common cause of death, about twice as frequent as death from stroke.^{14,114,115,116,220} Thus, the annual mortality from myocardial infarction is taken at 3% for patients 1 and 3. For patient 2, who has a less severe stenosis than the other two patients, these risks are lower, i.e. a 1.5% annual stroke risk and a 2% annual fatal myocardial infarction risk. We assume that treatment with ASA will result in a 15% (5%-25%) reduction in the rate of fatal stroke and of fatal myocardial infarction and in a 30% (20%-40%)

reduction in the rate of non-fatal disabling stroke, conform the antiplatelet trialists' collaboration study.¹¹ It is assumed that the effectiveness of ASA in reducing the stroke rate does not depend on the source of the TIA's (aneurysm or carotid artery).

Endarterectomy

For patients with a severe symptomatic stenosis the risk of any major stroke is reduced by 80%, both in the North American Symptomatic Carotid Endarterectomy Trial Collaborators' study (NASCET) and in the European carotid surgery trial (ECST). For patients with a less than 30% symptomatic stenosis in the ECST the procedure does not seem to have any benefit. Enrollment of patients with a moderate (30%-69%) symptomatic stenosis still continues.^{110,284} The only other large randomized trial of endarterectomy was conducted almost 20 years ago. In the group of TIA patients, the rate of stroke after uncomplicated endarterectomy was reduced by two-thirds, but this benefit was neutralized by peri-operative mortality and morbidity.¹¹⁶

We estimate the efficacy^b of endarterectomy at 50% (25%-75%) for patients 1 and 3, who have a 50% stenosis, and at 10% for patient 2, who has an ulcerating lesion without significant stenosis. It is not likely that the effect of endarterectomy in individual patients will persist. Therefore we let the efficacy of endarterectomy decline to 10% after five years in patients 1 and 3, and (with a similar rate) to 2% in patient 2. The peri-operative mortality and morbidity was taken at 2% (1%-4%) and 4% (2%-8%), respectively. In the two recent multicentre trials the surgical mortality was lower (1%), but these studies represent the work of highly experienced surgeons^{110,284} After release of the cross-clamp during endarterectomy middle cerebral artery blood flow as measured by transcranial Doppler is increased, but probably because of auto-regulation, the mean common carotid artery pressure is not.³⁵⁴ We therefore did not consider endarterectomy as a risk factor for aneurysm rupture.

4.3 Results

Computation of life expectancies

Patient 1, who is 63 years old, has a life expectancy of 15.0 years according to the Dutch life tables,⁵⁶ but because of the excess mortality from myocardial infarction, stroke and aneurysm rupture his life expectancy would be 10.2 years without further treatment, using the base-case estimates. ASA increases the life expectancy with 0.2 to 0.5 years for each strategy. Aneurysm surgery and ASA yields the highest life expectancy, 10.77 life years, 0.27 life year more than 'Wait & ASA'. However, for most patients aneurysm surgery is less attractive than suggested by crude life-expectancies, because it has a risk of immediate death. This is illustrated in Figure 22, that shows the survival probabilities with each of the four ASA-strategies for patient 1.

'Wait & ASA' offers the highest disability-free life expectancy for patient 1, but 'Aneurysm surgery & ASA' offers the highest overall life-expectancy. Therefore health status should be taken into account. Each life year spent in disability is weighted with a 'utility' $U = 0.75$

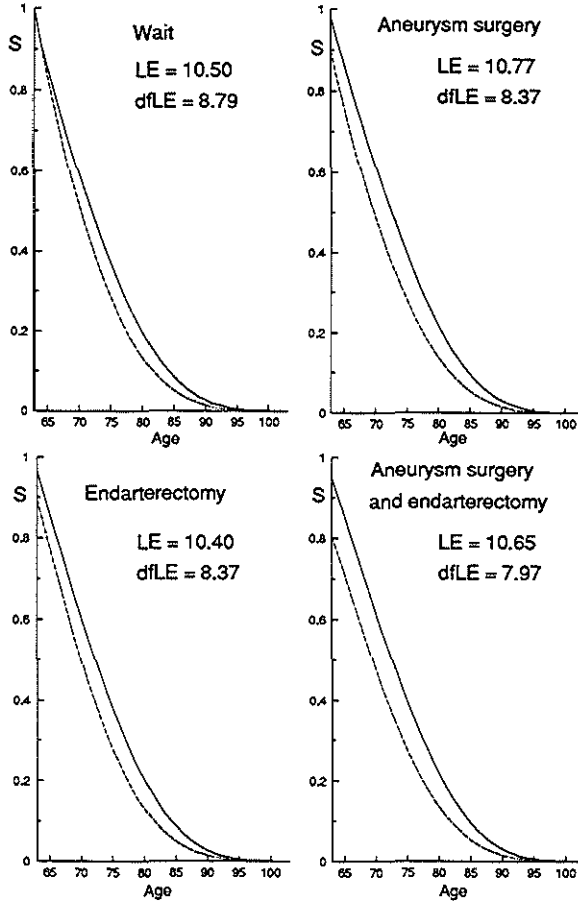

Figure 22. Survival and disability free survival for the four strategies with ASA, for the key patient. X-axis: Age in years. Y-axis: Cumulative survival probabilities (S). Solid line: survival, dashed line: disability free survival. In each graph the life expectancy (LE) and the disability-free life expectancy (dfLE) is listed.

(plausible range 0.625-0.875), compared to death ($U=0$) and a year in normal health ($U=1$).³⁸² This results in a quality adjusted life expectancy (QALE) that is somewhat lower than the crude life expectancy. The surgical options are affected more severely by this adjustment because of the risks of surgical morbidity.

Most patients attach more value to nearby than to distant life years.²⁶² An annual discount rate of 5% (0%-10%) is therefore used, i.e. each further life year is only valued at 95% (90%-100%) of the year preceding it. In this way, the unattractiveness of 'immediate risks' is taken into account. For patient 1 discounting decreases the life expectancy of the surgical option more than the life expectancy of 'Wait & ASA'. When both considerations are effective, the (discounted quality adjusted) life expectancy of 'Wait & ASA' and 'Aneurysm surgery & ASA' are equal. For patient 2, 'Aneurysm surgery & ASA' is slightly better in terms of discounted quality adjusted life expectancy, but this benefit strongly depends on the chance that the aneurysm causes the TIA's, see the sensitivity analyses. For patient 3, 'Aneurysm surgery & ASA' yields the highest discounted quality adjusted life expectancy. The ranking of the strategies for this patient is only slightly affected by discounting and quality adjustment.

Sensitivity analyses

The influence of plausible changes in the estimates on the dQALE of the strategies is investigated. Figure 23 illustrates the toss-up situation with regard to conservative treatment and aneurysm surgery for the key-patient. Plausible changes in the mortality and morbidity from aneurysm surgery, and in the annual rate of IA rupture have a relatively large influence on the difference between aneurysm surgery and conservative treatment. Endarterectomy is never the preferred strategy. The benefits of treatment with ASA outweigh its risks (increased mortality from SAH) in the three patients.

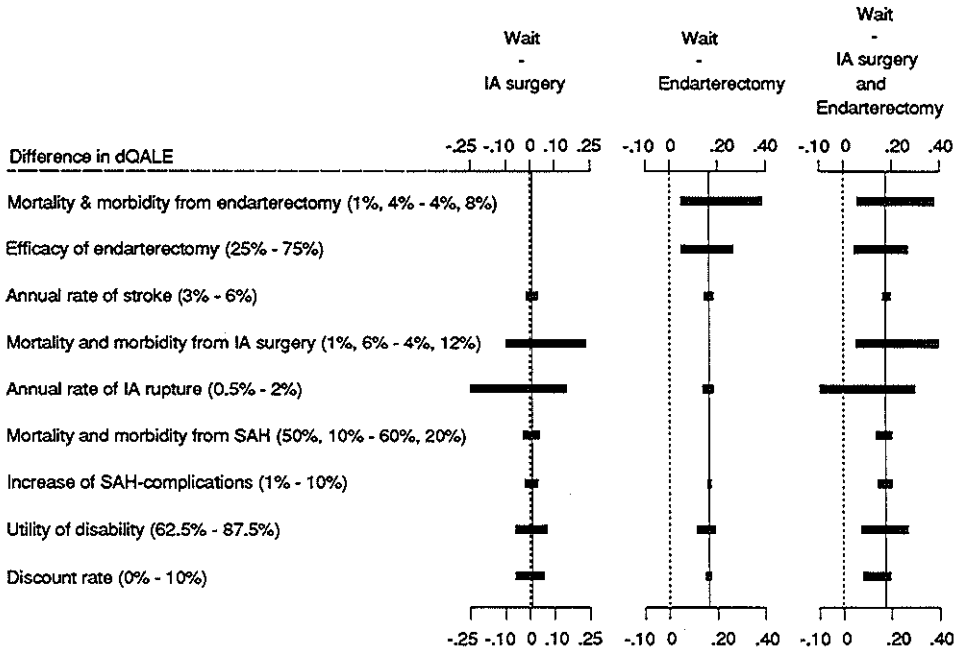

Figure 23. One-way sensitivity or influence analysis for the key patient. Dependency of the difference in dQALE between 'Wait' and 'Aneurysm surgery', 'Wait' and 'Endarterectomy' and 'Wait' and 'Aneurysm surgery and endarterectomy' on plausible changes in estimated probabilities. Positive values favour 'Wait'. All strategies include ASA.

Full Bayesian analysis

The many strategies, assumptions and variables that have to be considered in this clinical problem have made the analysis quite complex. The sensitivity analysis above considered each variable separately. An overall statement on the desirability of the available strategies for patient 1, when the uncertainty in all estimates is taken into account simultaneously, needs a full Bayesian analysis.¹⁴² For each variable, probability distributions were defined conform Doubilet^{90,142} (see also section 2.4, Chapter 2). Then, the cumulative distribution functions of the difference in expected utility between 'Wait & ASA' and 1) 'Aneurysm surgery, ASA', 2) 'endarterectomy, ASA' and 3) 'Aneurysm surgery, endarterectomy & ASA', were estimated in a series of 1000 Monte Carlo simulations. Figure 24 shows the 95%-confidence limits for the

difference in dQALE between 'Wait & ASA' and the three surgical strategies for the key-patient. The mean of the difference is equal to that in the base-case analysis, almost 0 discounted quality adjusted life year.

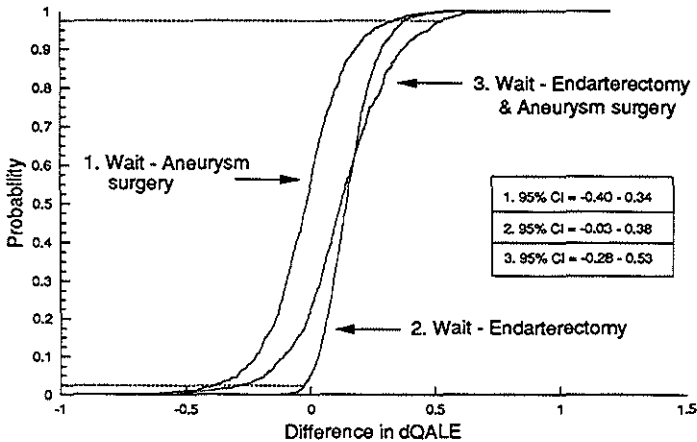

Figure 24. Full Bayesian analysis, taking into account the uncertainty in all estimates simultaneously. The cumulative distribution of the difference in discounted QALY (X-axis) between 'Wait' and 'Aneurysm surgery' (1), 'Endarterectomy' (2) and 'Endarterectomy and Aneurysm surgery' (3), respectively, estimated in a series of 1000 Monte Carlo simulations. All strategies include ASA. Dotted lines show the 95% confidence limits.

In order to make generalizations of this analysis to other patients, we computed 95% confidence intervals from series of Monte Carlo analyses with fixed values for the chance that the aneurysm causes the TIA's, and for the age of the patient. Three situations were considered: a) the aneurysm cannot be responsible for the TIA's, as in the case of the key-patient, b) the TIA's are equally likely to be caused by the aneurysm or not, as in patient 2, and c) the aneurysm certainly causes the TIA's. The last situation is important because it reveals the maximum benefit to be gained from clipping of the aneurysm. In the computations all other estimates were taken equal to those of the key-patient. When the probability that the aneurysm is responsible for the TIA's equals 50% or more, the difference between 'Wait and ASA' and 'Aneurysm surgery and ASA' exceeds 0.5 discounted QALY and is 'statistically significant' for patients aged 70 years or less, see Figure 25.

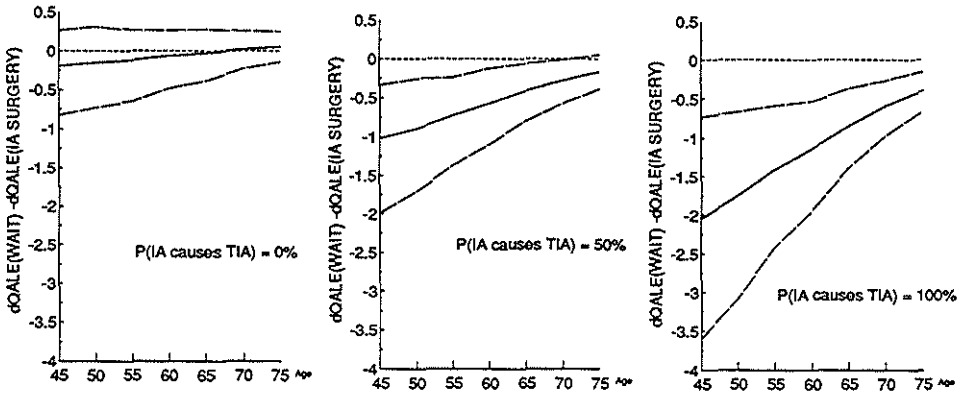

Figure 25. The influence of the assumption that emboli from the aneurysm cause the TIA's on the decision to clip the aneurysm. Mean (solid lines) and 95% confidence limits (dashed lines) for the difference in discounted QALE (Y-axis) between 'Wait & ASA' and 'Aneurysm surgery & ASA' for fixed values of the chance that the aneurysm causes the TIA's estimated in 7 times 3 series of 1000 Monte Carlo simulations. The dotted line signifies the zero or no difference level.

4.4 Discussion and conclusions

Decision analysis has been used for three patients with transient ischaemic attacks, a carotid lesion and an unruptured aneurysm. A clinically useful treatment advice is obtained from the analysis. First, ASA is strongly advised for all three patients. Endarterectomy cannot be recommended with confidence, even when the risk of stroke would be very high, the complication rate very low, and its efficacy high. With respect to surgical or non-surgical treatment of the aneurysm, a toss-up situation exists for patient 1, and surgical treatment of the aneurysm has the edge in patient 2. For patient 3 clipping of the aneurysm is strongly recommended, despite the gaps in our knowledge. The decision is stable; it is only changed by the three-fold combination of a low probability of rupture, high surgical mortality and morbidity, and a high discount rate. For patient 1, there will be no great loss if one or the other option is chosen, provided that platelet aggregation inhibitors are administered.

Additional considerations may make the decision more clear-cut for patient 1 and 2. We did not include minor strokes and transient ischaemic attacks, and we did not consider the inconveniences caused by surgery, nor the psychological stress of living with an unruptured aneurysm. For a discussion of this latter aspect, see Chapter 11. Some of these factors favour surgery, others not. However, when one is forced to make a decision it would not be logical to choose the option with the lowest $dQALE$.

We included endarterectomy in the analysis, although a beneficial effect of the procedure for our type of patients has not been demonstrated. Further results of on-going trials have to be awaited.²³ But even with low surgical risks, endarterectomy does not result in a large benefit for our type of patients.

We have been able to make a decision oriented synthesis of the available knowledge on this complex clinical problem. Not only an individualized treatment advice is produced, but also the insight into the clinical problem has been deepened. This makes it possible to apply the results of this analysis to patients with a similar problem. We identified the risk of rupture of the IA and the surgical mortality and morbidity of clipping, and the chance that the aneurysm caused the TIA as the most influential sources of uncertainty.

For patients with TIA's, a moderate carotid stenosis and an intracranial aneurysm that does not seem to be related to the symptoms, clipping of the aneurysm, nor endarterectomy can be recommended with confidence, but when the IA is just as likely the source of the TIA's as not, clipping is recommended up to the age of 70, when the surgical risks are as high as in the key-patient.

Of course, clinical judgment is crucial in adopting these conclusions, especially when the patient exhibits features that are not considered in the analysis.

Notes

- a. This chapter is adapted from: Dippel DWJ, Vermeulen M, Braakman R, Habbema JDF. *Transient ischaemic attacks, carotid stenosis and an intracranial aneurysm. A decision analysis. Accepted for publication.*
- b. Efficacy is defined as the relative reduction in risk of any stroke, i.e. $((P(\text{stroke}) - P(\text{stroke} \mid \text{endarterectomy})) / P(\text{stroke})) \times 100\%$. A value of 0% means no reduction, and 100% means total elimination of stroke risk.

Chapter 5

Treatment of intact familial intracranial aneurysms^a

The familial occurrence of subarachnoid hemorrhage (SAH) from intracranial aneurysms (IA) has been reported in several studies.^{126,283,363,364} Although a certain proportion of the familial IA's can be explained merely on the grounds of IA-prevalence, the greater part has been considered as a distinct IA-group with an autosomal dominant mode of inheritance.^{152,283,363} Elective screening for intact IA's in asymptomatic first-degree relatives of families in which two or more individuals have IA's has been strongly advocated and carried out.^{126,295,368} We studied two families, affected with IA, by means of intravenous digital subtraction angiography (iv-DSA). Four intact IA's, present in four different first-degree relatives, were successfully operated. We discuss the management of unruptured familial IA's based on these four cases.

5.1 Patients

Two families were studied. Family 1 contained seven members with IA's, one with SAH and two other members with Marfan syndrome and an unclassified congenital anomaly syndrome. In family 2, one member had a ruptured IA and another had a SAH without IA-detection (Figure 26). Elective screening for IA's was carried out in the asymptomatic first-degree relatives. The clinical data of these families are described elsewhere.^{109,363,368} In four patients intact IA's were detected, three of them belonging to family 1 (patient 1-III-14, 1-III-29, 1-III-32), and one to family 2 (patient 2-II-2). The characteristics of these patients and their aneurysms are summarized in Table 9. The routine laboratory analysis of all patients showed normal values: no cardiovascular abnormalities were present, except for mild hypertension in patient 1-III-14. The surgical management was uneventful in all patients except for patient 1-III-14. Postoperatively this patient had mild mixed aphasia and right facial weakness, which deficits disappeared within two weeks.

Table 9. Clinical characteristics of the four patients with an unruptured familial aneurysm.

Patient	Sex/Age	Site	Size	Peculiarities
1-III-14	M/51	LMCA	10x15 mm	no clear neck
1-III-29	M/47	PCA	6x15 mm	aneurysmal SAH 1965
1-III-32	M/34	LICA	5x6 mm	no clear neck
2-II-2	F/34	PCA	6 mm	-

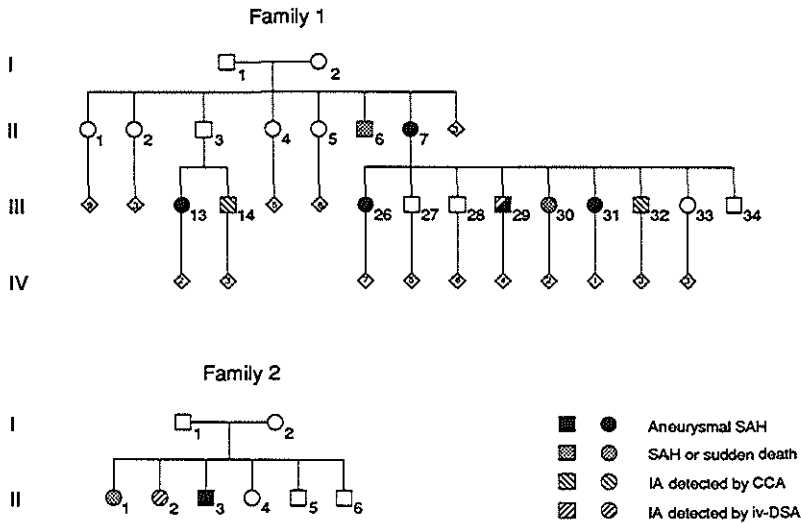

Figure 26. Pedigree of family 1 and family 2.

5.2 Methods

Essentially, decision analysis offers a method to balance qualitatively and quantitatively different factors against each other. Clinical decision analysis is mostly used to aid in decision making under conditions of uncertainty.^{315,396} However, it can also be used as a method to validate decisions that have already been carried out. In validating the neurosurgical treatment of the four patients we used a recently published decision-analytical study concerning the management of intact non-familial aneurysms.³⁹² The risks and benefits of diagnostic evaluation are not considered in the present study.

In Figure 27 the decision tree is shown. The decision 'no surgery' is represented in the upper part of the tree. Minor and transient morbidity related to a possible SAH in later life is not considered. This part of the tree is a condensation of subtrees, representing the probability that the aneurysm ruptures after one year, after two years ...etc. The decision for neurosurgical treatment is represented in the lower part of the tree. Again, minor and transient morbidity is not considered. It is assumed that after the neurosurgical procedure there is no risk of rupture.

The occurrence of familial IA's in association with other diseases, such as the Ehlers-Danlos syndrome, is not considered in the analysis. Multiplicity of IA's is also excluded.

By definition, members of families affected with IA's have a greater tendency than normal subjects to develop an intracranial aneurysm. Consequently, there may also be a substantial risk of development and (after that) rupture of a second aneurysm for the patients in this study. This is illustrated by the clinical course of patient 1-III-29. The development of a second aneurysm has not been reported in studies concerning familial aneurysms. We did not include this possibility in the decision tree, but we will discuss it after the presentation of the results of the base-case analysis.

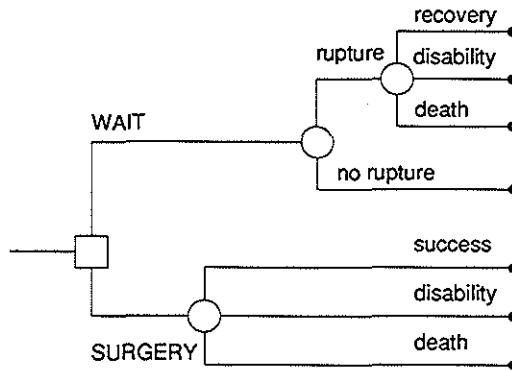

Figure 27. Decision tree for the management of unruptured familial intracranial aneurysms.

5.3 Available data and estimates

The estimates that emerge from this section are summarized in Table 10. The annual rate of rupture of non-familial IA's has been estimated at 1% (0.5-2%).^{164,382,409,410,411} The mean age of patients with SAH from familial aneurysms is significantly lower than that of patients with SAH from non-familial aneurysms.²⁹⁵ This may be explained by IA development at a younger age, and/or by a higher tendency to rupture. Therefore we assumed a larger plausible range for the annual rate of rupture (.5-3%). The probability of rupture may increase with size.⁴⁰² We assumed patient 1-III-14 and 1-III-29 to have a slightly higher probability of rupture than the other two patients, because of the size of their aneurysm. Mortality and morbidity after SAH of familial aneurysms is assumed to be similar to that of non-familial SAH: 55% and 15%, respectively.^{7,169,293}

Surgical mortality of intact non-familial IA's has been reported in small series from highly experienced centres at 0-2.5%, and the irreversible morbidity after surgery has been reported to be 6.5% or less.^{165,330,332,413} We used subjective estimates of surgical risks in the four patients. Main factors that were considered are: size and shape of the aneurysm, and location. These subjective estimates compare well with the results of Wirth.⁴¹³ In this series, irreversible morbidity was 2.3% for IA's 5mm or smaller, 6.8% for IA's 6-15 mm and 14% for IA's 16-25 mm. In general, large IA's in less accessible sites with difficult anatomical relations are associated with higher morbidity.^{218,378} Increasing age was not associated with higher morbidity.⁴¹³

We addressed the possible development of a second aneurysm as follows. From the age-related prevalence of unruptured aneurysms, as reported by McCormick²⁵⁸ in an autopsy study, the approximate annual rate of developing an aneurysm can be calculated for the general population. A minimum estimate of this risk would be 0.3% annually. The maximum approximation arises from the assumption that the second aneurysm develops immediately after the treatment decision has been carried out. This situation may be approximated by adding up a mortality rate of 0.6% ($1\% \times 55\%$, or risk of rupture \times mortality from SAH) to the life table mortalities.

A utility structure based on discounted Quality Adjusted Life Years is used.³⁸² Using the Dutch life tables for men and women (1981-1984),⁵⁶ we calculated the probability of being in state WELL, DISABILITY OR DEATH in each year n ($0 < n < t$) in which t equals 100 minus the age of the patient. The expected utility of each strategy equals the total sum of the probabilities of being in each state (WELL, DISABILITY OR DEATH) times the corresponding utility value of that year n . This utility value is expressed as $U(X) \times (1 - \alpha)^n$, in which α is the discount value. Disability is valued at 0.75 (0.625-0.875) compared to perfect health (1) and death (0). The appreciation of nearby life-years is supposed to be larger compared to distant years.²⁶² Therefore, 5% annually will be discounted, with a range of 0%-10%.

Table 10. Estimated values and probabilities.

All patients	Point value (plausible range)	
Mortality from SAH	55% (50%-60%)	
Morbidity from SAH	15% (10%-20%)	
Annual discount	5% (0%-10%)	
Utility of disability	75% (62.5%-87.5%)	
	1-III-14	1-III-29
Annual rate of rupture	1.25% (0.5%-3%)	1.25% (0.5%-3%)
Surgical mortality	3% (1.5%-6%)	2% (1%-4%)
Surgical morbidity	15% (12%-21%)	8% (6-12%)
	1-III-32	2-II-2
Annual rate of rupture	1% (0.5%-3%)	1% (0.5%-3%)
Surgical mortality	1% (0.5%-2%)	1% (0.5%-2%)
Surgical morbidity	4% (3%-6%)	4% (3%-6%)

5.4 Results

Expected utilities (EU) of both therapeutic options were computed for all four patients (Table 11), by "averaging out" the decision tree.^{315,396} In every patient, the option of surgical treatment yields the highest EU in the base-case analysis, although the difference between the two options is zero when rounded in patient 1-III-14.

Table 11. Expected utilities of conservative EU(WAIT) and neurosurgical treatment (EU(SURG) for patient 1-III-14, 1-III-29, 1-III-32 and 2-II-2, in discounted quality adjusted life expectancy (dQALE). A value of 0 stands for immediate death. $\delta = EU(SURG) - EU(WAIT)$. (d)LE = (discounted) life expectancy without mortality from surgery, or subarachnoid haemorrhage.

Patient	EU(WAIT)	EU(SURG)	δ	dLE	LE
1-III-14	13.0	13.0	0.0	13.9	24.8
1-III-29	13.8	14.3	0.5	14.9	28.4
1-III-32	16.1	17.0	0.9	17.4	40.6
2-II-2	16.8	17.8	1.0	18.2	46.6

Plausible changes in estimated data do not change the preferred option for patient 1-III-32 and patient 2-II-2, see Table 12. For example, with a low, but plausible estimate of the annual rate of rupture of the aneurysm of 0.5% (instead of 1%), surgery would still be the favoured treatment decision for these two patients, according to the analysis. For patient 1-III-29, a low, but plausible annual rate of rupture would change the preferred option to conservative treatment. For patient 1-III-14 there appears to be no clinically significant difference between the two options.

Table 12. Sensitivity analyses for patient 1-III-14 and patient 1-III-29 showing the effect of plausible changes in estimates on the differences between the expected utilities of conservative treatment ($EU(WAIT)$) and neurosurgical treatment ($EU(SURG)$).

	Patient 1-III-14				Patient 1-III-29		
	WAIT	SURG	δ		WAIT	SURG	δ
Annual rate of rupture							
0.5%	13.5	13.0	-0.5	0.5%	14.5	14.3	-0.2
3%	11.9	13.0	+1.1	3%	12.6	14.3	+1.7
Mortality and morbidity from SAH							
50%/10%	13.1	13.0	-0.1	50%/10%	13.9	14.3	+0.4
60%/20%	12.9	13.0	+0.1	60%/20%	13.7	14.3	+0.6
Utility of disability							
62.5%	12.9	12.7	-0.2	62.5%	13.8	14.2	+0.4
87.5%	13.0	13.2	+0.2	87.5%	13.9	14.5	+0.6
Annual discount							
0%	22.5	23.2	+0.7	0%	25.5	27.3	+1.8
10%	8.7	8.5	-0.2	10%	9.0	9.1	+0.1
Surgical mortality and morbidity							
1.5%/12%	13.0	13.3	+0.3	1%/6%	13.8	14.5	+0.7
6%/21%	13.0	12.3	-0.7	4%/12%	13.8	13.9	+0.1

For patients 1-III-14 and 1-III-29 we performed a more extensive sensitivity analysis, in which estimates of surgical mortality and morbidity, the annual rate of rupture and annual discount are varied over their plausible range of values (Figure 28). In this figure the influence of our maximum and minimum assumptions regarding the development of a second aneurysm are incorporated. From this figure it can be concluded that for patient 1-III-29, only combinations of high surgical mortality and morbidity, low risk of rupture and high discount clearly favour conservative treatment. For patient 1-III-14 the situation is more complex: there exists an almost

perfect toss-up.²⁰⁷ Thus, not only surgical mortality, risk of rupture and discount value, but also our estimates of the development and rupture of a second aneurysm become critical to the decision to treat the patient neurosurgically.

5.5 Discussion

As far as we know, elective neurosurgical treatment of intact familial IA's has been reported before in 7 individuals belonging to four other families.^{45,105,126,295} No definite agreement exists about the surgical treatment of intact IA's, both with isolated and familial occurrence. Neurosurgical treatment of non-familial intact aneurysms has been advocated for aneurysms 5 mm or larger,¹⁶⁴ 7 mm or larger,²⁹⁰ or 10mm or larger.⁴⁰² These estimates were based on the supposed risk of rupture of the aneurysm, in relation to size. A significant part of IA's smaller than 5 mm however, also rupture.²⁰⁵ There are more factors involved in the management decision. Van Crevel³⁸² showed for this kind of clinical problem how decision analysis can help in combining explicit estimates of all relevant parameters in a systematic and consistent way. It is an advantage of this method that all assumptions are made explicit. Also, the place that each probability and value should have in the process of clinical decision making is clarified, whether it is precisely quantifiable or not. This may promote and facilitate the discussion of this complex management problem. Thus, the estimated probabilities and values are open to challenge. For instance, the neurosurgeon (C.T.) who treated three of the four patients, made markedly lower individual estimates of surgical mortality and morbidity, but at that moment he was already aware of the satisfactory outcome of the patients. Moreover, our estimates of surgical mortality and morbidity are rather high in comparison with the available literature. But one has to realize that only very experienced neurosurgeons have published their results. In general, excellent surgical results will have a higher probability of being published than average results. This "publication bias" has been discussed in detail by Sackett.^{328,329}

Decision analysis helps to identify gaps in clinical knowledge that are really worthwhile exploring.²⁰⁶ In the course of this analysis it appeared that empirical data on the natural history (with respect to the probability of rupture and the development of new aneurysms) of familial aneurysms are lacking. However, it will be difficult, and sometimes even unethical to conduct a study to find out the risk of rupture of familial aneurysms. On the other hand, we were short of representative data on the results of surgery of intact intracranial aneurysms. There is a need for well documented series that make it possible to identify risk factors for surgical mortality and morbidity such as size, shape and location of the aneurysm. More knowledge of these factors would have made our analysis more accurate.

Although there are many blank areas in this decision-analytic approach of the management of familial aneurysms, we think that we have shown that the decision to treat the aneurysm neurosurgically in patients 1-III-29, 1-III-32 and 2-II-2 was a rightful one. In the last two patients, plausible changes in estimated data do not change this decision. For patient 1-III-29, only the

Figure 28. Threshold analyses for patient 1-III-14 and patient 1-III-29. The graphs show for surgical mortality and morbidity (X-axis), annual probability of rupture of the aneurysm (Y-axis), discount and maximum (dotted lines) and minimum (base-case) estimates of the and rupture of a second aneurysm the combination of parameters that results in an equal Expected Utility of the two treatment strategies (WAIT and SURGERY). The black dot shows the base-case-estimates that are used in the analysis.

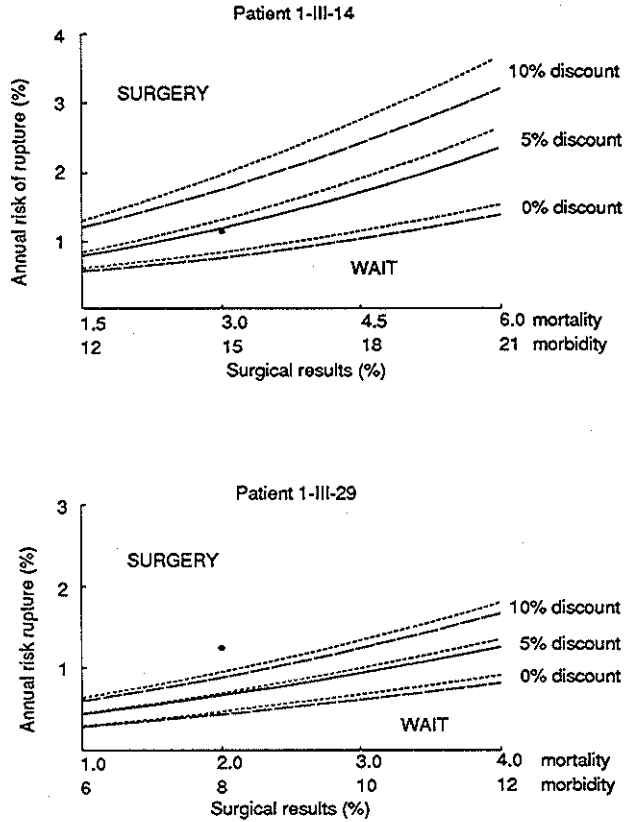

(rather unlikely) combination of a low probability of rupture, a high surgical mortality and morbidity and high discount favours conservative treatment. For patient 1-III-14 a toss-up exists, so both options are open. Still, a neurosurgeon who feels that familial aneurysms carry a greater risk of rupture than a normal, "idiopathic" aneurysm, or who thinks that the psychological burden of living with an unruptured, familial aneurysm will be very heavy for this patient, behaves not unreasonably by clipping the aneurysm of patient 1-III-14.

Notes

a. This chapter is adapted from: Ter Berg JWM, Dippel DWJ, Habbema JDF, Bijlsma JB, Van Gijn J, Tulleken CAF, Willemsse J. Treatment of intact familial intracranial aneurysms: A decision-analytical approach. *Neurosurgery* 1988;23:329-334.

Chapter 6

Screening for unruptured familial intracranial aneurysms^a

Several studies of families with an unusually high frequency of ruptured intracranial aneurysms (IA's) have been reported.^{45,126,152,238,364} The etiology of the aggregation of IA's in such families has not been established, but hypotheses focus on collagen deficiencies.³¹¹ In the clinical literature, the working definition of 'familial IA's' is applied when two relatives harbour a definitely established (ruptured) IA.

Ter Berg detected unruptured IA's in two patients by means of iv-DSA and earlier in two others by means of conventional cerebral angiography (CCA) by screening two families.³⁶⁸ Elective neurosurgical treatment was successful.^{363,365} In the present study, the decision to screen has already been carried out, with favourable results. A good result however, does not guarantee that the best choice was made. Therefore, we will assess the decision to screen retrospectively. Decision analysis is used as a framework to combine clinical information, subjective estimates of uncertainty and preferences for health-outcomes.^{19,206,396} The results should be considered as guide-lines for decisions, that have to be adapted to individual patients.

Four clinically relevant strategies will be considered in this analysis, i.e. no angiography at all (DO NOT SCREEN) screen directly (SCREEN NOW), screen directly and again after several years if the first angiogram was negative (SCREEN TWICE), screen after several years only (SCREEN LATER). We will use a baseline value of five years for the screening-interval, conform Ter Berg.³⁶⁸ Each screening strategy can be carried out using ia-DSA or iv-DSA. The latter seems safer, but is less accurate. In a scenario analysis¹⁴² magnetic resonance angiography (MRA) will be analyzed tentatively.

6.1 Material and Methods

Patients

Forty patients (36 belonging to Family 1 and 4 belonging to Family 2, Figure 29) were screened with iv-DSA in 1982.³⁶⁸ Two new IA's were detected. Ages ranged from 10 to 54; 25 patients were younger than 30. Five years later screening was repeated in 31 members of family 1. No new IA's were detected. Member 1-III-34 of family 1 (a 39-year-old male) was admitted two years after the second screening with a ruptured posterior communicating aneurysm. Ia-DSA also revealed two aneurysms of the right internal carotid artery and the basilar trunk, all approximately 3 mm. On review, the earlier angiograms were negative.³³⁷

Member 1-III-33, a woman aged 37 with five relatives who had an angiography- or autopsy-proven IA before screening, and two relatives who suddenly died without firm diagnosis,^b will be used as a key patient throughout the decision analysis.

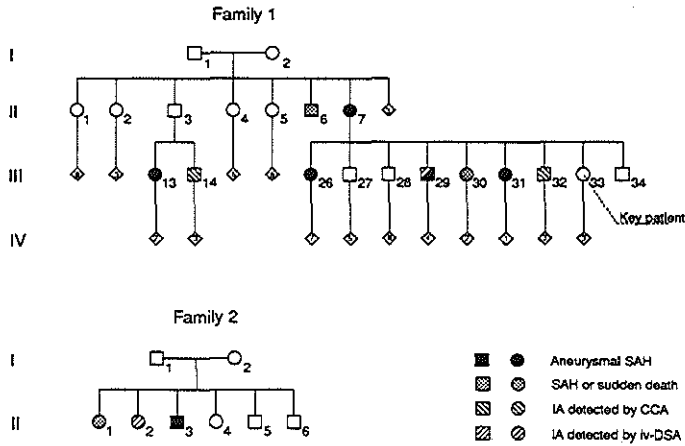

Figure 29. Pedigree of family 1 and family 2. Member 1-III-33 is used as a key patient throughout the analysis.

Methods

The events and outcomes that relate to each strategy will be described in an orderly way. A decision tree is used as an illustrative tool. The likelihood of events and outcomes (probabilities) and the desirability of outcomes relative to each other (utilities or losses) are quantified. The probability estimates are based on a concise review of the relevant literature. Then, the expected loss (EL) of each strategy is computed. The strategy with the lowest expected loss can be considered as a good advice. At last, sensitivity analysis is used to examine the effect of plausible changes in quantifications on the expected loss of each strategy, to test the stability of the advice and to validate the results of the analysis for other patients.^{216,315}

The 'expected loss' can be defined as the (abstract) health-loss that occurs on average, by following the chosen strategy. Loss of life expectancy (LE) will be used as a proxy for the expected loss in this analysis. It is computed for each strategy by subtracting the expected survival from the life expectancy according to the Dutch life tables.⁵⁶ The survival for each strategy is estimated by combining data from the Dutch life tables with estimates related to the presence of IA's and to the diagnostic and therapeutic interventions.

Differences between strategies in LE lost do not necessarily match patient preferences, because morbidity is not considered. Therefore quality adjusted life expectancy (QALE) is computed as follows. Three health states are defined (Alive & Well, Disability and Death) and

the expected number of life years spent in each health state is computed for each strategy. Each year lived in disability is weighed with a utility value of 0.75 (plausible range: 0.625-0.875), on a scale of 0 (Death) to 1 (Alive & Well). Alive & Well corresponds to "no or moderate disability", and disability to "severe disability" according to the Glasgow outcome scale.

Many patients attach more value to nearby than to distant life years.²⁶² For example, surgical management - with the possibility of immediate death - will generally be considered as less attractive than conservative management when both options yield an equal life expectancy. Therefore, the expected loss is expressed as loss in discounted life expectancy (dLE), by valuing each life-year at 95% (plausible range: 90%-100%) of the year preceding it. Both procedures are combined in the computation of discounted quality adjusted life expectancy (dQALE) lost.

Decision tree

In strategy DO NOT SCREEN in the decision tree of Figure 30, an unruptured IA may cause SAH resulting in death, serious permanent neurologic disability, or recovery. Compared to the calculations in the analysis, the time aspect has been simplified in the tree. Haemorrhage and development of new IA's, which may occur at any time in the future, have each been combined into one branch. It is assumed that after a non-fatal SAH the IA is clipped, completely preventing further haemorrhage. Cavernous carotid artery aneurysms are not considered because they seldom rupture, and operation is hazardous.

Strategy SCREEN NOW involves a choice of the type of angiography (iv-DSA or ia-DSA). These may be complicated by mortality or permanent major (neurologic) morbidity. Following a positive iv-DSA, ia-DSA is used to confirm the IA and to locate it more accurately. Strategy SCREEN TWICE is first identical to SCREEN NOW, but after several years, angiography is repeated. Strategy SCREEN LATER implies on the one hand a risk of haemorrhage before screening, but on the other hand a larger probability of finding an IA, because new IA's may develop. The remaining part of the tree is identical to that of SCREEN NOW.

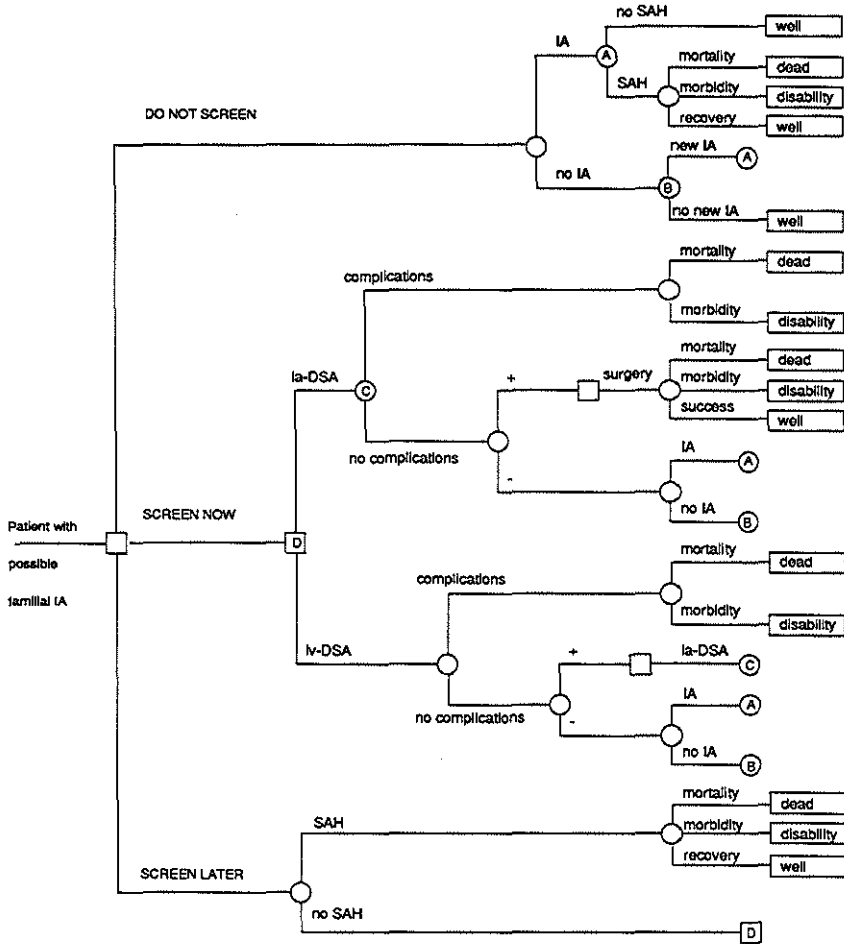

Figure 30. Decision tree for patients from a family affected with intracranial aneurysms. IA = intracranial aneurysm, SAH = subarachnoid haemorrhage, ia-DSA = intra-arterial digital subtraction angiography, iv-DSA = intravenous digital subtraction angiography, + indicates that angiography suggests presence of IA, - indicates that angiography suggests absence of IA. Square: decision node, circle: chance node, rectangle: outcome-node. For upper case letters in terminal chance-nodes corresponding subtrees should be inserted. Strategy SCREEN TWICE is not displayed for reasons of space. It can be constructed by inserting subtree D after each non fatal outcome branch of strategy SCREEN NOW.

6.2 Available Data and Estimates

The estimates for the key-patient (member 1-III-33) are summarized in Table 13. Because of the uncertainty surrounding these estimates, plausible ranges are suggested.

Probability of harbouring an aneurysm

The risk of harbouring an IA is based on McCormick's autopsy study of unruptured intracranial aneurysms.²⁵⁸ The probability of harbouring an unruptured IA at age 10 is 0.5%, steadily increasing to 8% at age 70. The key patient (aged 37) would have a probability of harbouring an unruptured IA of 1.2% (0.6%-2.4%). However, she has several close relatives with a definitely established IA. We therefore assume an increased risk, although the exact relation between the number of affected family members and the probability of harbouring an IA is not known. The relative risk R due to the familial disposition^c is taken at 3 (1-5). An upper-bound of 5 corresponds to a 50% cumulative incidence of IA's (ruptured and unruptured) at age 80, as in an autosomal dominant mode of inheritance with complete expression.

Natural history of aneurysms

Intracranial aneurysms rupture at a rate of 1% (0.5%-2%) annually.^{112,164,189,306,382,409,410,411} The haemorrhage may result in mortality, morbidity or recovery with probabilities of 55% (50%-60%), 15% (10%-20%) and 30% (20%-40%) respectively.^{7,169,293,382,401}

Ruptured aneurysms are on average larger than unruptured IA's. Therefore, the mean rate of growth is estimated at 0.075 mm (0.06 mm-0.09 mm) annually, i.e. every year 7.5% of IA's enlarge 1 mm.^{5,201,402,403} It is assumed that the IA's do not become symptomatic when they reach large sizes. The annual probability of a new IA is estimated from McCormick.²⁵⁸

Angiography: test characteristics

No estimates of the sensitivity and the specificity of angiography for intracranial aneurysms are available. Artifacts are virtually impossible when a three-direction ia-DSA shows an IA. Thus, it is assumed that ia-DSA has a 100% specificity.

Because the likelihood of being detected by angiography increases with aneurysm size, we estimated its influence on the sensitivity of angiography, by comparing the distribution of aneurysm sizes in an autopsy study²⁵⁷ and a study of conventional cerebral angiography (CCA) of unruptured IA's.⁴¹³ After adjusting for the effect of fixation / non-perfusion by a factor of 1.5 (as proposed by McCormick)²⁵⁷ and for differences in age-composition, the ratio of these two distributions gives the relative likelihood of being detected on the angiogram, by aneurysm size. This likelihood is converted to a function of size-related sensitivities by assuming a minimum size of 5 mm (3 mm-10 mm) where the probability of being detected by ia-DSA is 100%. The estimates are extrapolated to iv-DSA by assuming that a sensitivity of 100% is reached at a size of 10 mm (range: 5 mm-15 mm).

The overall sensitivity of angiography (i.e. the probability of discovering an IA of any size, when the patient really harbours an aneurysm) depends on the size distribution of IA's, which differs according to the age of the patient and the preceding diagnostic procedures. In the key patient ia-DSA would have an overall sensitivity of 75% at the time of first screening. At the second screening it would be lower (63%) because the first screening was negative and the distribution of IA-sizes will have been shifted towards smaller ones. Postponement of the first screening for five years leads to larger IA-sizes and to a higher sensitivity (79%). The effect of new IA's on the size distribution is negligible.

Table 13. Point values and plausible ranges of parameters entering the decision analysis for patient 1-III-33, a woman of 37 with 5 close relatives with a definite ruptured IA.

	point value	range
Natural history of aneurysms		
Probability of IA (population prevalence)	1.2%	0.6%-2.4%
Relative risk of familial IA	3	1-5
Annual rate of rupture	1%	0.5%-2%
Mortality of SAH	55%	50% - 60%
Morbidity of SAH	15%	10%-20%
ia-DSA		
Mortality	0.02%	0.01%-0.04%
Morbidity	0.2%	0.1%-0.4%
Specificity	100%	-
Overall sensitivity (SCREEN NOW)	75%	27%-93%
Overall sensitivity (SCREEN TWICE)	63%	28%-95%
Overall sensitivity (SCREEN LATER)	79%	30%-83%
Iv-DSA		
Mortality	0.01%	0.006%- 0.02%
Morbidity	0.1%	0.06%-0.2%
Specificity	95%	90%-100%
Overall sensitivity (SCREEN NOW)	38%	24%-63%
Overall sensitivity (SCREEN TWICE)	38%	27%-79%
Overall sensitivity (SCREEN LATER)	41%	20%-53%
Surgery		
Mortality	2%	1% - 4%
Morbidity	6%	4% - 10%
Patient preferences		
Annual discount	5%	0% - 10%
Utility of disability	0.75	0.625-0.875

Angiography: complications

No mortality and a permanent morbidity rate of 0.3%-0.4% has been reported in two large studies.^{83,97} Iv-DSA is usually regarded as less dangerous than intra-arterial angiography, but

the evidence is limited. In one study no mortality and a permanent morbidity of 0.2% was reported, but all patients were studied for extracranial vascular disease.¹⁵ Aaron's study is not considered, because an intracardial catheter was used, resulting in a high morbidity.¹

The risks from angiography seem to increase with age.^{83,248-250} Therefore we assumed a linear relationship between age and complication risks. The mortality is assumed to be 10 times lower than morbidity. For the key patient these estimates result in a risk of permanent major complications and death of 0.2% and 0.02% for ia-DSA, and 0.1% and 0.01% for iv-DSA.

Surgical mortality and morbidity

Surgical mortality of intact non-familial IA's has been reported at 0-2.5%, and the irreversible morbidity at 6.5% or less.^{165,218,290,330,332,413} These figures are quite susceptible to publication bias.³⁸² Consequently we used subjective estimates,³⁶⁵ and investigated a wide range of values for surgical mortality (1%-4%) and surgical morbidity (4%-10%).

6.3 Results

Base-case analysis

For each strategy, both for ia-DSA and iv-DSA the LE lost is computed, see the leftmost column in Table 14. DO NOT SCREEN gives patient 1-III-33 - who has a 3.6% risk of harbouring an IA - an expected loss of 0.24 life years (approximately 3 months) compared to the situation in which one would be certain that she did not harbour an IA. SCREEN NOW with ia-DSA results in a lower loss (0.13 life years or 1.5 months) because IA's that are discovered will be treated, and this outweighs the risk of the diagnostic procedure and surgery. Postponing screening for five years (SCREEN LATER) does not seem to be beneficial for this patient. SCREEN TWICE provides the lowest loss of the four strategies when LE is used as outcome measure. Strategies involving iv-DSA have a slightly higher expected loss, approximately 0.05 life years or 2-3 weeks more. The lower risk of complications with iv-DSA is apparently outweighed by a lower diagnostic accuracy. All losses are quite small, because of the low prior probability of an IA. For comparison, a 37-year-old woman who harbours an IA with certainty loses on average 6.9 life years.³⁸²

Although SCREEN NOW provides a higher life-expectancy than DO NOT SCREEN, the time spent in disability is larger (0.07 versus 0.21 life years). Patients will differ in their preferences for these outcomes. Therefore we also computed the loss in quality adjusted life expectancy (QALE). This increases the expected loss for each strategy, but DO NOT SCREEN is least affected.

In the same table it is shown how preferences a discount rate of 5% (0%-10%) affects the results. The loss for all strategies is reduced, but again, DO NOT SCREEN is spared. Combining preferences for time and health outcome on one scale of discounted quality adjusted life expectancy (dQALE) results in almost equal losses for SCREEN NOW and DO NOT SCREEN, and also for the other two strategies.

Table 14. Expected losses of seven strategies for patient 1-III-33, expressed as loss in life expectancy with quality adjustment, discounting and both. The third (non-significant) digit is rounded to 0 or 5. Normal life expectancy for a 37 year-old woman, without mortality from IA rupture or surgery would be 43.09 years, and 16.00 years with discounting.

Strategy	Life years lost due to the intracranial aneurysm			
	No adjustment	Quality adjustment	Discounting	Quality adjustment and discounting
DO NOT SCREEN	.235	.250	.055	.060
ia-DSA				
SCREEN NOW	.130	.180	.035	.050
SCREEN TWICE	.120	.190	.030	.060
SCREEN LATER	.150	.200	.040	.055
iv-DSA				
SCREEN NOW	.180	.220	.045	.055
SCREEN TWICE	.160	.215	.040	.060
SCREEN LATER	.200	.235	.050	.060

Sensitivity analyses

We investigated the effect of plausible changes in each estimate on the preferred decision,¹⁴² see Table 15. Not shown are plausible changes in the probability of complications from SAH, the growth rate of the IA, surgical mortality, specificity and sensitivity of iv-DSA. They have a very low impact, especially on the difference in expected loss between DO NOT SCREEN and SCREEN NOW. The relative risk of a familial IA is the most influential factor in this analysis. High values favour SCREEN NOW.

When the mortality and morbidity associated with ia-DSA is increased to 0.04% and 0.4% respectively, the expected loss of SCREEN NOW with ia-DSA equals the expected loss of SCREEN NOW with iv-DSA.

We assumed that the annual rate of rupture of IA's is constant with respect to size. When we let it increase linearly with size, such that a 15 mm (10-20mm) IA has 1.5 (1.25-2.00) times the probability of rupture of a 2 mm IA, this does not lead to different conclusions.

Table 15. Sensitivity analysis for patient 1-III-33: The differences in number of discounted quality adjusted life years lost between strategy DO NOT SCREEN and strategy SCREEN NOW for ia-DSA and iv-DSA are shown. Negative values favour DO NOT SCREEN.

	ia-DSA	iv-DSA
base-line values	0.01	0.00
Natural history of aneurysms		
Probability of IA		
0.06%	0.00	0.00
2.4%	0.03	0.01
Relative risk of familial IA		
1	-0.01	0.00
5	0.04	0.02
Annual rate of rupture		
0.5%	-0.01	-0.01
2%	0.02	0.03
ia-DSA		
Mortality/morbidity		
0.01%/0.1%	0.01	0.00
0.04%/0.4%	0.00	0.00
iv-DSA		
Mortality/morbidity		
0.006%/0.06%	0.01	0.01
0.02%/0.2%	0.01 ^d	0.00
Value judgments		
Utility of disability		
62.5%	0.00	0.00
87.5%	0.02	0.01
Annual discount		
0%	0.07	0.03
10%	0.00	0.00

Generalizations

In order to generalize the results to other patients, we examined the joint effect of the relative risk of a familial IA and age on the difference in dQALE lost between DO NOT SCREEN and SCREEN NOW (Figure 31). At a young age the risk of harbouring an IA is very small, and therefore the benefits of screening are low. With increasing age, benefits increase, and an optimum is reached between 40 and 60. At older age, lifetime rupture risks decrease rapidly because of a lower

life-expectancy. This results in a smaller benefit of surgical treatment, although the risk of harbouring an IA increases. The differences between DO NOT SCREEN and SCREEN NOW for iv-DSA (not shown) are about half the value of those for ia-DSA.

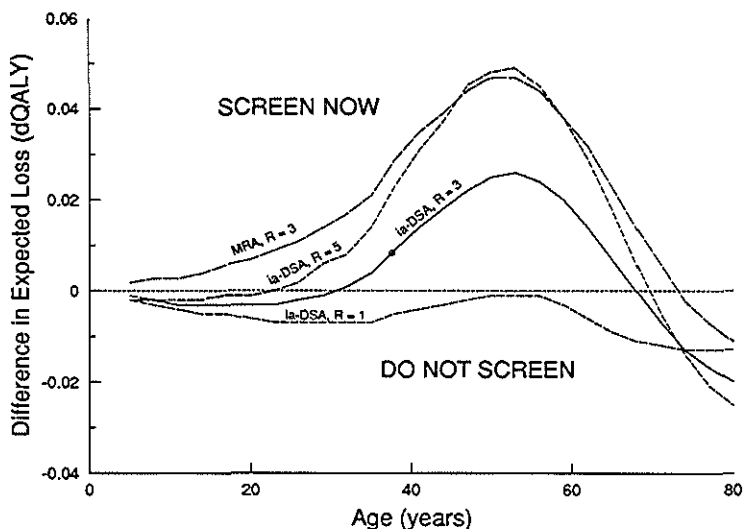

Figure 31: The effect of age and of the relative risk of a familial IA (R) on the choice between screening directly with ia-DSA and no screening. Y-axis: difference in expected loss between DO NOT SCREEN and SCREEN NOW in discounted quality adjusted life years (dQALE). X-Axis: Age in years. Solid line: base-case estimate ($R=3$), dashed lines: $R=1$ and $R=5$, respectively. A horizontal dotted line representing an equal loss is shown for orientation. The position of patient 1-III-33 is indicated by an open circle. The differences in EL between DO NOT SCREEN and SCREEN NOW with iv-DSA are approximately half as large as with ia-DSA. A dashed line depicts the effect of screening with magnetic resonance angiography (MRA), when it would be completely reliable.

Scenario analysis

Magnetic resonance angiography (MRA) has the advantage of non-invasiveness, but the detection and study of diseased vessels is complicated by the great number of visualized arteries and veins.^{299,324} We computed the expected loss of the three screening-strategies using this new device, as if it had a diagnostic accuracy mid-between that of iv-DSA and ia-DSA, without the associated mortality and morbidity. Then, the dQALE lost for the key patient of SCREEN NOW, SCREEN TWICE and SCREEN LATER amounts to 0.04, 0.03 and 0.04, which is slightly lower than

for ia-DSA. Because there is no mortality and morbidity and therefore no penalty on repetitive testing, SCREEN TWICE has the lowest expected loss in this situation. The previous figure also shows the difference in dQALE lost between SCREEN NOW and DO NOT SCREEN as if MRA would be a perfect test. Even in this case the differences in expected loss are only slightly larger than with ia-DSA.

6.4 Discussion and conclusions

The analysis for the key patient results in a toss-up. Only when the likelihood of an IA is higher than our point estimate, a clinically significant benefit of screening will arise. Even then, however, the difference in loss of dQALE is only in the order of magnitude of several days. The results of this analysis certainly provide no justification for screening of patients who do not have a familial history.

A decision analysis that yields small differences in expected loss between the strategies should be carefully reviewed, as "minor simplifications" may lead to wrong recommendations.²⁰⁷ Therefore, we will elaborate upon several of our assumptions.

A strategy for the whole family is not considered, because the benefits of finding and treating an IA will vary individually. However, the results of screening one family member will affect the prior probability of IA in yet unscreened members, and the balance between risks and benefits of screening. The time-loss (because of hospitalization) and transient morbidity due to angiography, surgery and SAH are not considered. Nor did we include the anxiety caused by the notion of possibly living with an unruptured IA. Note however that a negative screening result does not completely exclude an IA, but only makes its presence less likely. Iv-DSA can be carried out on an ambulatory basis. For this reason it may be preferred over ia-DSA in individual cases, considering the small differences in expected loss.

A screening device without mortality and morbidity, and perfect test characteristics will only slightly decrease the expected loss. The difference in dQALE lost between SCREEN NOW and DO NOT SCREEN is in this case at best 0.07. Thus, use of non-invasive technology - such as MRA - will result in only a slightly larger benefit than ia-DSA. Cost considerations may then play a more prominent role in deciding about indications for screening.

We used the relative risk as a summary measure of the evidence for an unruptured IA, by judging the family history. When two members of a family have suffered an SAH, and this aggregation was fortuitous, the risk that any other family member harbours an unruptured IA is not increased. But when this aggregation was based on a pathologic, hereditary process, other family members will have an increased risk of harbouring an unruptured IA. There are no laboratory tests that distinguish between 'normal' IA's and 'familial' IA's. The probability

of "chance aggregation" is much larger than one would expect. For example, a patient who is admitted with SAH has a 9% chance of having at least one close relative out of 29 (up to the third degree) who also had an SAH.

Family members up to the third degree will be considered, and the average number of children in a household (c) is taken at 3. Thus, there are 5 first degree (2 parents+ c children), 2 second degree (2 siblings) and 22 third degree relatives ($2 \times (c - 1)$ parents' siblings, $(c - 1) \times c$ cousins, and $2 \times (c - 1) \times c$ uncles or aunts), making the total number N of relatives to be considered 29.

Assume that each family member has a risk of harbouring an unruptured IA $p = 0.01$. We took the annual rate of rupture at $r = 0.01$, and the mortality from SAH at $m = 0.55$. The mean age a of the relatives is taken at 40.

The probability that a patient who is admitted with SAH has at least one close relative with previous SAH just by chance, is described by:

$$P = 1 - (1 - p(1 - (1 - r)^a))^N = 0.092 = 9.2\% \quad (16)$$

When the estimate is restricted to relatives who are alive, the equation is extended to

$$P = 1 - (1 - p(1 - (1 - r(1 - m))^a))^N = 0.047 = 4.7\% \quad (17)$$

The proportion of familial cases explained by fortuitous aggregation in Norrgård,²⁸³ can be estimated by taking $c=2.8$, and by considering only parents, siblings, parents' siblings and cousins ($N=17$). P would be 0.056 or 5.6 % which is quite near to the proportion reported in that study: 6.7%, (95% confidence interval (normal approximation): 3.5%-9.9%).

Thus, the observation that two members of one family have a history of SAH should not increase one's suspicion much. On the other hand, a physician who thinks that the risk of harbouring an IA of a certain patient is substantially increased because of the possible familial disposition, may rightly decide for screening, especially for patients aged 40 to 60. He should use ia-DSA, which seems better than iv-DSA. A stepwise approach may be best, from the viewpoint of this decision analysis. Start screening the relatives whose age lies between 40 and 60 and who are closely related to the propositus, in the first or second degree. And let the decision to screen others depend on the results of these first investigations.

Notes

- a. This chapter is adapted from: Dippel DWJ, Ter Berg JWM, Habbema JDF. Screening for unruptured familial intracranial aneurysms. A decision analysis. *Acta Neurol Scand* 1992; 86: 381-389.
- b. Patient II-6 dropped from his chair and died soon afterward. Patient I-III-30 presented with acute headache and vomiting, neck rigidity, peripapillar haemorrhages and blood-stained cerebrospinal fluid.
- c. In the epidemiological literature the relative risk is normally taken as the ratio of the incidence with and without exposure to a determinant ($R = P(IA | F) / P(IA | \bar{F})$). In our case, however, $P(IA | \bar{F})$ is unknown, and R is taken relative to the population incidence ($R = P(IA | F) / P(IA)$).
- d. Identical to base-case value. The strategies with ia-DSA do not depend on assumptions about io-DSA. But, in strategies with io-DSA, ia-DSA is used to confirm the presence of an IA preoperatively.

Chapter 7

Unruptured intracranial arteriovenous malformations^a

Familial occurrence of non-syndromal intracranial arteriovenous malformations (AVM's) has been seldom reported: only 16 families are known.^{4416,419} Familial occurrence of intracranial AVM's as a feature of a hereditary syndrome is still more exceptional. To the best of our knowledge, hereditary haemorrhagic telangiectasia (HHT) or Rendu-Osler-Weber disease is the only known syndrome with a high frequency of vascular anomalies with both intracranial and spinal localization. HHT is a familial disorder with generalized angiodysplasia and multiple cutaneous, mucosal and visceral telangiectasia and other vascular anomalies with a hepatic, intracranial, intraspinal and pulmonary localization, including pulmonary arteriovenous fistulae (PAVF).³³⁴ HHT has an autosomal dominant mode of inheritance with high penetration and variable expression. Two families affected with both HHT and vascular anomalies of the central nervous system (CNS) in more than one relative have been reported.^{39,211} Another family affected with AVM's is suggestive for HHT.⁴¹⁹

We describe three patients belonging to two different families, affected with both HHT and unruptured, intracranial AVM's. The unruptured AVM's were detected using cerebral angiographic screening.

The risks of surgery and its effectiveness depend on the size and location of the AVM. Young patients have a high lifetime risk of haemorrhage, and therefore one may be inclined to take more risks when attempting to extirpate the AVM. However, no definite agreement exists about the indications for surgical treatment of unruptured AVM's.^{57,358} Radiation therapy and arterial embolisation are also risky procedures, and they seem to be less effective than surgery in eliminating the AVM.^{31,243,314} Embolisation is mostly used as a pre-operative procedure to eliminate deep arterial branches, and "stereotactic radiosurgery" is mostly confined to AVM's that are inoperable because of location near non-silent brain areas.²⁸⁷ These possibilities will not be considered here. The analysis will be restricted to a choice between surgery and conservative management.

The surgical treatment of both non-syndromal unruptured intracranial AVM's and (familial) AVM's associated with HHT will be discussed on the basis of these three patients. In deciding about the best management option for each patient, the risks of harbouring an unruptured AVM, the risks associated with HHT, the risks and benefits of surgery and the patients' own preferences with regard to future life-years and to living with a serious neurological handicap should be considered. As in previous studies of the management of unruptured intracranial aneurysms, we will use clinical decision analysis to incorporate the available information in a balanced framework.^{86,365,382} The results of this decision analysis will be generalized to patients with non-familial AVM's.

7.1 Patients and Methods

Patients

Angiographic screening for unruptured intracranial vascular anomalies using intravenous digital subtraction angiography (iv-DSA) was carried out on a group of 18 patients affected with HHT, known at the Department of Pulmonology, St. Antonius Hospital, Nieuwegein, The Netherlands (CJJW). AVM's were detected in three patients, see Table 16. The lesions will be described according to a grading system proposed by Spetzler³⁵⁵ using three variables: size (1: <3 cm, 2: 3-6 cm, 3: > 6 cm), pattern of venous drainage (0: superficial, 1: deep), and neurological eloquence of the adjacent brain region (0: non-eloquent, 1: eloquent).

Table 16. Description of the three patients for the decision analysis of the surgical management of unruptured intracranial AVM's.

	Sex	Age	PAVF	AVM location	Grade
A-II-5	M	14	no	r-MCA	1-0-0
A-I-2	F	43	yes (resected)	l-PCA	2-0-1
B-III-1	F	12	no	l-ACA	1-0-0

PAVF: Pulmonary Arteriovenous Fistula; ACA = Anterior Cerebral Artery, MCA = Medial Cerebral Artery, PCA = Posterior Cerebral Artery

Family A (see pedigree, Figure 32) harbours six members who are affected with HHT, of whom four (patient I-2, II-1, II-3 and II-6) were treated surgically for symptomatic PAVFs (hemoptysis and right to left shunt). The PAVF relapsed in patient II-1, II-3 and II-6. In patient II-5, male, aged 14 and right handed, iv-DSA revealed an unruptured grade 1-0-0 AVM, fed by the right middle cerebral artery and drained by the superior sagittal sinus. Follow-up angiography four years later did not show a change in size. In patient I-2, female, aged 43, iv-DSA revealed an unruptured grade 2-0-1 asymptomatic AVM, fed by the left posterior cerebral artery and drained by the transverse sinus (eloquent region: hemianopsia). Follow up angiography after 3 years did not show a change in size.

Family B has two members with intracranial vascular lesions. In patient III-1, a twelve year old girl, iv-DSA showed an unruptured grade 1-0-0 AVM fed by the left anterior cerebral artery and drained by the superior sagittal sinus. Follow-up iv-DSA 4 years later did not show a change in size. Neurosurgical treatment was uneventful. Her father, who was also affected with HHT died from subarachnoid haemorrhage at age 29; the autopsy report mentioned an intracranial aneurysm of the anterior communicating artery.

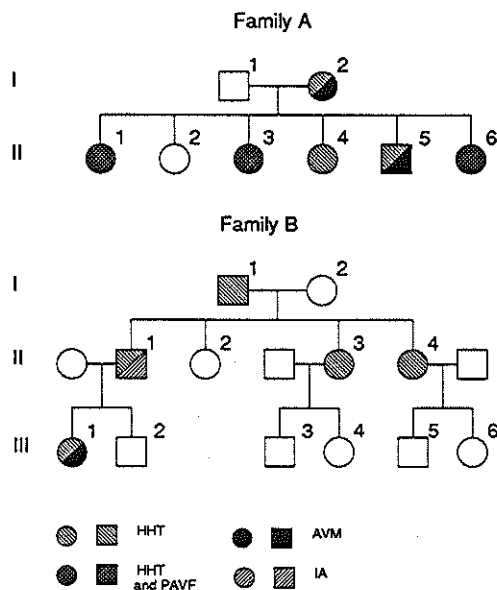

Figure 32. Pedigree of two families with hereditary haemorrhagic telangiectasia (HHT) and intracranial arteriovenous malformations (AVM's). Patients A-I-2, A-II-5 and B-III-1 harbour AVM's.

Methods

In decision analysis, the clinical problem is structured in a decision tree, see Figure 33. The surgical option (SURGERY) carries a risk of mortality and morbidity. After surgery the AVM may have been completely taken out of the circulation or not. Incompletely extirpated AVM's may rupture again. It is assumed that after non-fatal rupture of incompletely extirpated AVM's, effective surgery is not possible. In the lower part of the tree the no treatment-option is considered (WAIT). The patient has an annual rate of rupture of the AVM, and an annual rate of dying from other causes. Rupture of the AVM causes haemorrhage, and this may lead to recovery, permanent disability or death. Minor and transient morbidity related to haemorrhage and to neurosurgical treatment is not considered. It is assumed that a ruptured AVM will be surgically treated. Again, incomplete extirpation implies a risk of recurrent haemorrhage.

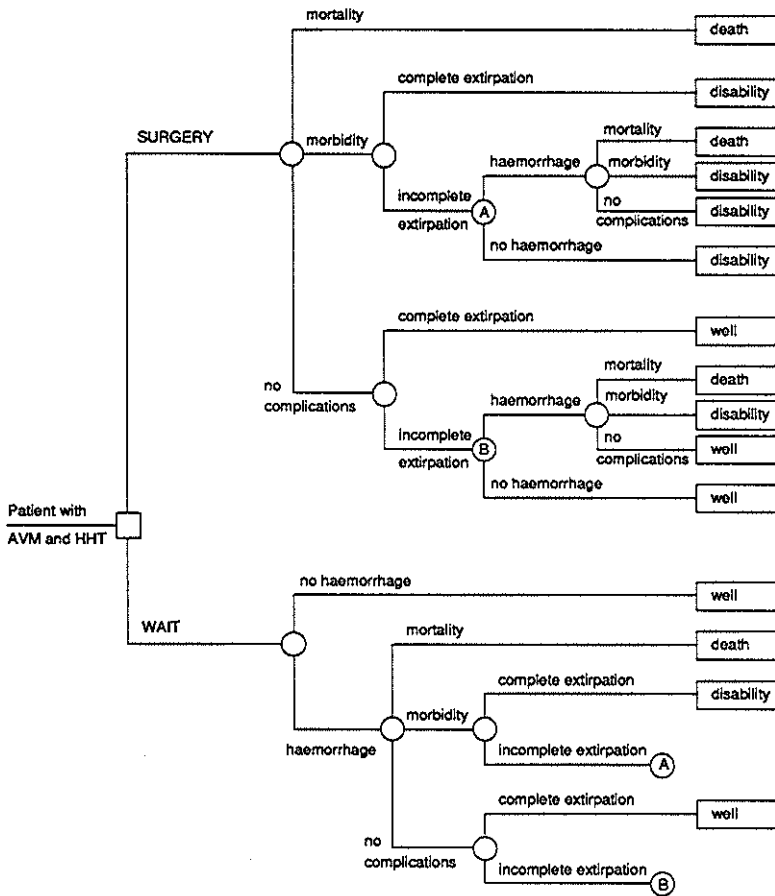

Figure 33. Decision tree for a patient with an intracranial arteriovenous malformation (AVM) and hereditary haemorrhagic telangiectasia (HHT). Two strategies are shown: expectant management (WAIT) and surgical management (SURGERY). Quadrangle: decision node, rectangles: outcome nodes, circles: chance nodes. A and B refer to the subtrees that represent the course of events after incomplete extirpation of the AVM.

In the decision analysis, the probability of haemorrhage is computed for each year that the patient survives. The Dutch life tables of 1986 are used to estimate the annual mortality from

other causes.⁵⁶ The time span that is covered equals 109 years minus the age of the patient. Risks and benefits of diagnostic evaluation are not considered in the present study. Also, the not unusual association of AVM with an intracranial aneurysm is not taken into account.

Three health states are considered in the decision analysis: *Well* (no complications or minor handicap), *disability* (severe permanent handicap, making the patient dependent upon others) and *death*. The average number of life years lived in each health state is calculated. For an overall judgment, a utility structure based on discounted quality adjusted life expectancy dQALE is used. For a detailed discussion of the use of dQALE see Chapter 2, section 2.3. Disability is valued at 75% compared to perfect health (100%) and death (0%).³⁶² (Later in the analysis it will be shown that the effect of quality adjustment on the results of the analysis is negligible.) The appreciation of future life years by patients is assumed to decrease gradually over time. Therefore, 5% will be discounted annually, with a range of 0-10%. The decision tree is evaluated by first computing the dQALE for each outcome. A further expectation is computed for each strategy by multiplying the probability of each outcome with its associated dQALE. The strategy with the highest dQALE should be regarded as a good advice.

7.2 Available data and estimates

In the following paragraphs, the literature will be reviewed to obtain estimates of the probabilities of events in the decision tree. Because of variability due to imprecision and uncertainty, plausible ranges will be suggested, see Table 17.

Natural history of unruptured AVM's

Several studies of the natural history of symptomatic arteriovenous malformations have been reported. A general problem of these studies (which are discussed in detail below) is that follow-up data are gathered by means of telephone-interviews and mailing of general physicians and relatives. Thus, patients with a haemorrhage may be more likely to be included in the study than those who have not (yet) bled. Moreover, determination of the moment that the patient should be regarded as lost to follow-up can be difficult, because of the retrospective nature of the study. This may lead to too high estimates of the risk of haemorrhage.

In Ondra's study²⁹¹ of 160 patients with AVM who were followed for a mean period of 23 years, 64 (40%) had at least one major haemorrhage. One hundred and fourteen 114 (71%) of these patients originally presented with haemorrhage. The authors did not distinguish between first and recurrent haemorrhage during follow-up. This explains why they report a higher annual rate of haemorrhage (4%) than in the other studies (see below). It makes the study difficult to interpret and not very useful for our analysis.

Brown⁴⁸ reports a long term follow-up study of 168 patients with clinically unruptured AVM's, (mean follow-up 8.2 years). Using Kaplan Meyer estimates a mean annual rate of haemorrhage of 2.2% was computed. Crawford⁶⁹ reports a 17% 10-year risk of haemorrhage and a 20-years risk of 33%, in 49 patients who presented without haemorrhage, for an annual

rate of almost 2%. In Graf's series¹³⁷ 71 patients presented with symptoms other than haemorrhage. The cumulative risk of haemorrhage was 14% in 5 years, for an "average annual rate of rupture" between 2% and 3%. In this study, a statistically significant increased risk of haemorrhage was observed for small (<3cm) AVM's, but this has not been reproduced in other studies.^{48,69,291} The larger proportion of small AVM's among patients who present with a bleeding AVM compared to those who present with an unruptured symptomatic AVM is of course no evidence for an increased risk of haemorrhage for smaller lesions, as Crawford already noted.⁶⁹ Older studies^{125,130,360,375} only have small groups of unruptured AVM's and often lack angiographic confirmation and consistent follow-up information.

Thus, the annual rate of haemorrhage of the AVM is estimated at 2% with a plausible range of 1%-3% on the basis of the studies above mentioned. We base our estimate of mortality and morbidity due to haemorrhage (30% and 25% respectively) on these studies also. No data exist about the comparison between the tendency to rupture of a familial AVM associated with HHT and a non-familial, non-syndromal AVM. We assume that the risks of haemorrhage and its complications are equal for familial and non-familial AVM's.

Mortality from other causes

Although the three patients whom we consider had no symptomatic PAVF at the time of the treatment decision, it is conceivable that latent, mostly basally located PAVFs become symptomatic, as illustrated in 3 members of family A. This can be explained by haemodynamic factors, such as post-operative changes. PAVFs may rupture or otherwise result in neurological signs, due to hypoxia, polycythaemia, thrombosis, air-embolism and paradoxical septic emboli. We investigated the effect of comortality by adding 0.5% (0%-1%) annually to the life table mortalities.^{82,240,346}

Surgery of unruptured AVM's

Values of 0%, 4%, 7% and 12% for the risk of permanent major neurological surgical morbidity in grade I-II, III, IV and V patients respectively have been reported in a series of 100 cases of both ruptured and unruptured AVM's.³⁵⁵ Cases in whom complete resection was not possible were excluded. In a retrospective series of 74 patients with low-graded (un)ruptured AVM's no mortality and a 4% morbidity was experienced.²⁴² In another series of 40 "small and moderately large" AVM's¹⁶⁶ no mortality, and a 5% morbidity was recorded. Older studies reported higher surgical mortality rates: 11% and 6% in a series of 100²⁹⁴ and 145 symptomatic AVM's,¹⁴⁰ but a distinction between ruptured and unruptured AVM's was not made, and several of the patients were in poor clinical condition prior to operation.

Still, published studies may give a too optimistic view of the results of neurovascular surgery as has been argued before.³⁶⁵ We therefore investigated a wide range of values for surgical

mortality and morbidity for each patient. In the computations, the probabilities $P(smr_b)$ and $P(smr_t)$ of surgical morbidity and surgical mortality, respectively are linked by the formula $P(smr_b) = 2 \times P(smr_t) + 0.025$.

Incomplete resection is not infrequent. This happened in 18 of 105 cases (from a total of 140 patients treated for AVM) studied by angiography after excision because of uncertainty about the surgical results.³⁴ This means an overall frequency of incomplete extirpation of AVM's of 12.5%. However, results according to clinical grade were not reported. For our patients, we used a 0% probability of incomplete extirpation. In order to investigate the effect of changes in this parameter, and to generalize the analysis to other patients we investigated a range of 0%-25% as plausible values.

Table 17. Point values and plausible ranges for the decision analysis of surgical management of unruptured AVM's.

	Point value	Plausible range
All patients		
annual rate of rupture	2%	1%-3%
mortality after rupture	30%	25%-35%
morbidity after rupture	25%	20%-30%
incomplete extirpation	0%	0%-25%
annual mortality due to PAVF and HHT	0.5%	0%-1%
annual discount rate	5%	0% -10%
utility of disability	75%	62.5%-87.5%
Patient A-II-5 and B-III-1		
surgical mortality	1.0%	0.5%-2.0%
surgical morbidity	4.5%	3.5%-6.5%
Patient A-I-2		
surgical mortality	2.5%	1.25%-5.0%
surgical morbidity	7.5%	5.0%-12.5%

PAVF = Pulmonary Arteriovenous Fistula; HHT = Hereditary haemorrhagic telangiectasia

7.3 Results

Base-case analysis

The life expectancy associated with surgical treatment and waiting for each patient are computed by averaging out the tree, see Table 18.

Patient A-I-2, who is 43 years old, would have a life expectancy (LE) of 37.6 years without mortality from AVM and HHT. The mortality risk associated with these conditions decreases her LE by several years, to 30.9 years with expectant management. Surgical management yields a 2.2 years higher LE, 33.1 years. Discounting future life years decreases the life expectancy for surgery more than for waiting, because of early surgical mortality. Quality adjustment does not change the results much. The two other patients are younger, and therefore have a higher lifetime risk of rupture^b. For these patients, surgery yields the best results. With discounting the difference between expectant management and surgery exceeds one discounted quality adjusted life year.

Table 18. Results of the comparison between surgical and expectant management of unruptured AVM's in the three patients in life expectancy with discounting (5%), quality adjustment or both. The life expectancy according to the Dutch life tables without mortality due to HHT or AVM with and without discounting is given for comparison.

	Patients		
	A-I-2 F-43	A-II-5 M-14	B-III-1 F-12
Sex - age			
Life expectancy (LE) (years)			
life table	37.6	59.4	67.8
surgical management	33.1	50.5	56.6
expectant management	30.9	44.7	49.6
difference in LE	+2.2	+5.8	+7.0
Discounted LE (dLE)			
life table	16.1	18.2	18.7
surgical management	14.7	16.7	17.0
expectant management	14.1	15.6	15.9
difference in dLE	+0.6	+1.1	+1.1
Quality adjusted LE (QALE)			
surgical management	32.5	49.9	56.0
expectant management	30.2	43.4	48.1
difference in QALE	+2.3	+6.5	+7.9
Discounted quality adjusted LE (dQALE)			
surgical management	14.4	16.5	16.8
expectant management	13.9	15.4	15.6
difference in dQALE	+0.5	+1.1	+1.2

Sensitivity analysis

In a sensitivity analysis (Table 19) we computed the dQALE for both strategies and investigated the effect of varying the values of each variable over a plausible range. Only high surgical risks change the preferred strategy for patient A-I-2. In the two other patients (not shown), the preferred strategy is not changed by plausible changes in estimated values. Other parameters of relatively great influence on the results of the analysis are: risk of haemorrhage, discount and risk of incomplete extirpation of the AVM.

Table 19. Sensitivity analysis for patient A-I-2: the effect of plausible changes in estimated probabilities and utilities on the discounted quality adjusted life expectancy of surgical and expectant management of unruptured intracranial AVM's. The base-line estimates are given for comparison. When the difference between dQALE of surgery and expectant management is positive, surgery is recommended. Apparent discrepancies are the result of rounding.

	SURGERY	WAIT	Difference
Base-line estimate	14.4	13.9	+0.5
Discount rate			
0%	32.5	30.2	+2.3
10%	8.3	8.2	+0.1
Mortality due to PAVF and HHT			
0%	15.4	14.8	+0.6
1%	13.5	13.1	+0.4
Annual rate of haemorrhage			
1%	14.4	14.4	+0.0
3%	14.4	13.7	+0.6
Mortality/morbidity of haemorrhage			
25%/20%	14.4	14.1	+0.3
35%/30%	14.4	13.7	+0.7
Risk of incomplete extirpation			
12.5%	14.3	13.9	+0.4
25%	14.1	13.9	+0.2
Surgical mortality/morbidity			
1.25%/5%	14.7	13.9	+0.8
5%/12.5%	13.8	13.9	-0.1
Utility of disability			
62.5%	14.3	13.8	+0.5
87.5%	14.6	14.0	+0.6

PAVF = Pulmonary Arteriovenous Fistula; HHT = Hereditary haemorrhagic telangiectasia

Generalization of the analysis

High surgical mortality and morbidity implies a relatively low dQALE of surgical treatment. Thus, for a certain value of surgical mortality and morbidity the dQALE of expectant management and surgery will become equal. For patient A-I-2 the "threshold value" of surgical mortality and morbidity is 4.6% and 11.7% respectively. (In the sensitivity analyses surgical mortality and surgical morbidity are linked algebraically, see previously.) When the actual estimate of surgical mortality and morbidity is higher than the threshold value, expectant management will be the preferred strategy. In Figure 34 the threshold values of surgical mortality and morbidity are computed for ages 0-80. For younger, but otherwise identical patients the threshold-value will be higher, because the life-time risk of haemorrhage is larger, making it more worthwhile to operate. This is illustrated by the straight line. Also indicated in this figure is the effect of plausible changes in the estimated annual rate of haemorrhage and the chance of incomplete extirpation of the AVM: low risks of haemorrhage and high chances of incomplete extirpation decrease the threshold value.

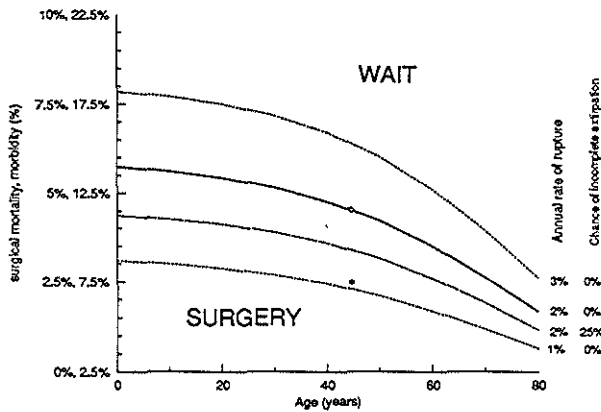

Figure 34. Threshold analysis of surgical results (Y-axis), age (X-axis) and rate of rupture. Each line represents a value for the annual rate of haemorrhage and gives combinations of values for age and surgical mortality and morbidity that result in equal dQALE for expectant management (WAIT) and surgical management (SURGERY). For combinations of values above each line expectant management is favoured, and below each line surgery. The dashed lines give the threshold values of surgical mortality and morbidity when the chance of incomplete extirpation of the AVM is 25% and 50% respectively. The open circle indicates the threshold value of surgical mortality and morbidity for patient I-A-2 aged 43 and the black circle indicates the base-case estimates for this patient. The threshold values in this graph bear on women; for men they are 0.2%-0.5% lower, because their lower life expectancy implies a lower lifetime risk of haemorrhage.

7.4 Discussion

Weighing the benefits of surgical treatment of unruptured AVM's, especially in association with HHT, is difficult because of the variability in clinical features, the inconclusive data concerning annual rate of rupture, mortality and morbidity after rupture, surgical morbidity and mortality, the probability of successful surgery and the relations between these factors. No prospective studies applying the AVM grading system^{241,355} have as yet been reported. Such data would be of great value. We assume that AVM's in association with HHT have the same annual rate of rupture as non-syndromal AVM's. As far as we know, no data have been reported that suggest otherwise.

We did not explicitly consider stereotactic radiation therapy and embolisation. These techniques may be helpful for young and otherwise healthy patients who do not seem to be clear-cut candidates for surgery, because of the location and/or size of the AVM (i.e. a left-temporal AVM). Decision analysis can be of value here, but individualised estimates of the rate of complications after radiosurgery, normal surgery and after rupture will be necessary.

In clinical practice, surgery is sometimes confined to people aged just below 30, because between 30 and 40 a "peak-incidence" of haemorrhage due to ruptured AVM's is observed.^{94,166,242,355} If one presumes a small, approximately constant annual rate of haemorrhage for an individual patient, there will be no theoretical basis to explain this "peak-incidence". It could well be caused by selection and classification artifacts in older patients. Moreover, not the annual rate of haemorrhage (or incidence density), but the life time risk (or cumulative incidence) of haemorrhage should be the principal consideration.

Other studies

Other decision-analytic studies on the management of arteriovenous malformations^{186,9,121} are discussed in Chapter 3.

Pertuiset³⁰⁰ proposed a score system for operability of supratentorial AVM's, which included anatomical (localization and sectorization, determination, caliber and straightening of feeding arteries), haemodynamic (volume, circulatory velocity, steal) and clinical considerations (age, previous rupture, associated diseases malformations of vital organs), based on a review of 66 cases, 14 of these presenting with haemorrhage. The authors do not describe how or why these variables were selected, nor how the scoring weights were determined. The important age-factor was dichotomized (less than 51, over 50) and high-age was considered as a contra-indication to surgery, which is an unnecessary simplification of the clinical situation. The score only considers surgical risks, and not the (long term) benefits of surgery.

Conclusions

Integration of more specified clinical characteristics of AVM's in grading systems leads to more differentiated management recommendations. Surgery of unruptured AVM's (both syndromal and non-syndromal) is the treatment of choice in selected cases. Considerations should include: the age of the patient, the risk of haemorrhage of the AVM, the chance of incomplete extirpation, surgical mortality and morbidity, and the patient's preferences. Patients with low graded AVM's that have not bled should be operated upon, unless they are over 60 years of age (or have a reduced life expectancy because of other disease) and the risk of incomplete extirpation of the AVM is increased.

HHT-patients appear to have an increased risk of harbouring vascular lesions of the central nervous system compared to the general population. In a review of 215 patients with HHT and (primarily and secondarily) cerebral symptoms 77 patients with telangiectasia, arteriovenous malformations or intracranial aneurysms were documented.³¹⁹ This high prevalence is also illustrated by our 3 patients affected with unruptured AVM's, out of a group of 18 HHT patients.

Thus, members of families affected with HHT have a greater chance of harbouring intracranial AVM's than in general. Screening of families affected with familial intracranial aneurysms using intra-arterial or intravenous digital subtraction angiography has already been discussed elsewhere.^{363,368} Screening for unruptured AVM's -not considered in this study- may be carried out in HHT families affected with intracranial AVM's in two or more individuals, but perhaps also in HHT-families without association of intracranial AVM's. A first screening using computed tomography scanning or magnetic resonance imaging or angiography (MRI or MRA) may be the best choice, because AVM's are generally well visualized by these techniques, and they are nearly non-invasive. In a recent report of a family with 8 members out of 16 with cerebral AVM's, Allard⁴ makes a strong case for screening with MRI. The benefits of further angiographic screening can be estimated only indirectly after assessment of the grade of the supposed AVM and the characteristics of the patient. Decision analysis should be used to confirm this recommendation.

Notes

a. This chapter is adapted from: Ter Berg JWM, Dippel DWJ, Habbema JDF, Westermann CJJ, Tulleken CAF, Willemse J. Unruptured intracranial arteriovenous malformations with hereditary haemorrhagic telangiectasia. Neurosurgical treatment or not? *Acta Neurochirurgica* 1993; 121: 34-42.

b. The lifetime risk of haemorrhage R can be estimated by the formula $R = 1 - (1 - r)^L$, where r is the annual rate of haemorrhage, and L is the life expectancy of the patient. For patient A-II-5 $R = 1 - (1 - .02)^{59.4} = 69.8\%$.

Chapter 8

Probabilistic diagnosis of normal pressure hydrocephalus^a

Although the number of publications on the management of normal pressure hydrocephalus (NPH) seems to decline more than 25 years since the first description of the syndrome,^{151,128} there is no consensus about its diagnosis and treatment.⁶⁶ Many patients who seem to have NPH do not respond to shunting, probably because irreversible damage has been done, or because these patients actually suffer from primary degenerative or multi-infarct dementia. As NPH is a clinically defined syndrome, a certain diagnosis cannot be made. We therefore propose a probabilistic approach to the diagnosis of NPH and other treatable cerebral lesions in demented patients. Clinical and pathological studies that investigated the occurrence of NPH and other treatable cerebral lesions in dementia have not systematically analyzed the diagnostic value of information obtained from history and physical examination.^{41,347,81} In the present study we combine epidemiological data, subjective probabilities and clinical reasoning in order to assess the impact of diagnostic features and age on the probability of NPH and of an intracranial space-occupying lesion (SOL) in a demented patient, before and after computed tomography. Decision analysis is used to weigh the risks and benefits of shunting for NPH and to give recommendations for the diagnostic and therapeutic management of demented patients who may suffer from this condition. The analysis is restricted to investigation with CT, because this belongs to the standard diagnostic management of patients suspected of NPH. The role of other diagnostic tools is less clear. Cisternography does not seem to add useful prognostic or diagnostic information,^{35,308,367} but MRI may prove useful in the distinction between NPH, multi-infarct dementia and white matter lesions.⁶³ These two tools will not be considered here, for lack of evidence. The role of external lumbar drainage, lumbar puncture and continuous pressure monitoring will be discussed.

8.1 Patients and methods

Patients

A fictitious patient will be used to illustrate the analysis. This 60-year-old woman suffered since six months from memory difficulties and disorientation in time. On neurological examination there was a fairly typical shuffling gait, but no other (focal) abnormalities. There were no depressive symptoms. Mini Mental Score was 20/30.¹²⁴ Details of physical, neurological and laboratory examinations are summarized in Table 20. Three other clinical profiles have been defined for comparison. They differ from the key patient with respect to the presence of gait abnormalities and urinary incontinence. These two features deserve some emphasis in our opinion because they are considered typical for patients with NPH, but their occurrence in patients with AD or MID may give rise to erroneous diagnoses and consequently, failure to

respond to shunting. In order to explore the effect of age on the likelihood of a treatable lesion four patients aged 75 with a similar clinical profile will be considered separately in the results section. We did not consider treatable lesions in patients with dementia of longer duration, as their response to shunting is disappointing.¹³⁸

Table 20. Clinical profiles differing in age, presence of gait abnormalities and urinary incontinence, and duration of the dementia. Key patient: bold text. All patients: Sixty year old white female, aged 60. Blood pressure: 155/95. Neurological examination: no dysphasia, no hemisindrome, tendon reflexes brisk, but not abnormal. Muscle tone normal. Plantar responses flexor. No extrapyramidal signs. Laboratory: normal blood count and electrolytes. Thyroid, liver and renal function normal for age. No deficiencies of vitamin B₁₂ or folate. Syphilis tests negative. Urine analysis normal. Lumbar puncture: CSF pressure normal and no clinical improvement (by measurement or assumption).

profile	duration of dementia (yrs)	age	urinary incontinence	gait abnormalities
1	0.5	60	No	No
2	0.5	60	No	Yes
3	0.5	60	Yes	No
4	0.5	60	Yes	Yes

For the purpose of this study, dementia is defined as a syndrome of deterioration from a known or estimated prior level of intellectual function which is not isolated to a single narrow category of intellectual performance, and which is independent of level of consciousness.⁶³ The relative incidence (in a hospital setting) of the four major cerebral causes of the dementia syndrome (i.e. NPH, intracranial space-occupying lesion (SOL), multi-infarct dementia (MID) or Alzheimer's disease (AD)) will be used as an estimate of the prior probability of each cause of dementia. These disease entities do not refer to a clinically defined syndrome, but to a presumed underlying cause of dementia. Other causes of dementia and depression are considered to be ruled out. Several other conditions may lead to a clinical picture of dementia and gait abnormalities, for example dementia pugilistica, dementia associated with Parkinson's disease, chronic alcoholism and multiple sclerosis. Multiplicity of disease is not considered. Next, the occurrence of a eight diagnostic features -all of which are obtainable by taking the patient's history and doing a physical examination- is assessed for each type of dementia. To this purpose the literature was searched systematically. A Medline search of the medical literature published since 1982 on epidemiology and diagnosis in DEMENTIA, ((PRE)SENILE), ALZHEIMER'S DISEASE, DEMENTIA VASCULAR, DEMENTIA MULTI-INFARCT and HYDROCEPHALUS NORMAL PRESSURE was carried out. Out of the 2242 journal articles a further selection was made by scanning the abstract for the above mentioned methodological aspects. Studies of the clinical

picture of the four causes of dementia were selected when the final diagnosis was based on prolonged follow-up, or histo-pathological confirmation. Sometimes only semi-quantitative or no estimates at all concerning the occurrence of diagnostic signs in each of the four causes of dementia were available in the literature. In that case we resorted to subjective estimates, made by the first author of this study.^b When exact data are not available plausible ranges for each point estimate were defined by taking a ratio for the upper and lower bounds of at least four. Then, a probability of each cause is computed for each patient.

Bayes' theorem is used to convert the prior probability (see Table 21) of each of the four considered causes of dementia C_i to a posterior probability, based on information contained in the absence or presence of diagnostic features DF (see Table 22).

$$P(C_i | DF) = \frac{P(C_i) \cdot P(DF | C_i)}{\sum_{j=1}^4 P(C_j) \cdot P(DF | C_j)} \quad (18)$$

DF stands for the eight "diagnostic features" from history and physical examination that are considered. The probability of a particular combination of DF is computed by taking the product of all the individual feature probabilities $P(D_k | C_j)$, with $k=1,2..8$:

$$P(DF | C_j) = \prod_{k=1}^8 P(D_k | C_j) \quad (19)$$

In order to adjust for the assumption of conditional independence, which is implied by Bayes' theorem, a global association factor ($X, 0 \leq X \leq 1$) is used.¹⁷²

$$P(DF | C_j) \propto \left(\prod_{k=1}^8 P(D_k | C_j) \right)^X \quad (20)$$

("∝" = "proportional to")

A value of 1/8 for X implies that diagnostic probabilities are completely dependent, a value of 1/2 implies pairwise dependence, and a value of 1 implies complete independence. Likewise, a value of 2/3 (as is used in this study) means that every three diagnostic items yield the information of two completely independent ones.

The log-odds form of Bayes' theorem is used to compute a score that can be converted to posterior likelihoods:

$$Score = 10 \times {}^2\log\left(\frac{P(C_i | DF)}{1 - P(C_i | DF)}\right) = {}^2\log\left(\frac{P(C_i)}{1 - P(C_i)}\right) + \sum_{k=1}^8 {}^2\log\left(\frac{P(D_k | C_i)}{P(D_k | \bar{C}_i)}\right) \cdot X, \quad (21)$$

where the subscore associated with each diagnostic feature j is computed by taking

$$Subscore_j = {}^2\log\left(\frac{P(D_j | C_i)}{P(D_j | \bar{C}_i)} \cdot X\right) \quad (22)$$

and $P(D_j | \bar{C}_i)$ is taken as the average of the diagnostic probabilities in the three other causes, weighted with their priors, and X is the global association factor.

The likelihood of successful shunting S in a patient suspected of NPH is computed by taking the product of the probability of successful shunting in patients who have secondary normal pressure hydrocephalus with certainty, and the probability of "idiopathic" or "primary" normal pressure hydrocephalus in the patients considered in this paper:

$$P(S | CT^+, DF) = P(S | NPH) \cdot P(NPH | CT^+, DF). \quad (23)$$

The next equation gives the algebraic representation of the decision tree in Figure 35, for the special case where the expected utilities of each option are equal to each other:

$$\begin{aligned} EU(Wait) &= EU(Shunt) \Leftrightarrow \\ U &= (1 - P(M)) \cdot (P(NPH) \cdot P(S) + P(NPH) \cdot (1 - P(S)) \cdot U) + (1 - P(NPH)) \cdot U. \end{aligned} \quad (24)$$

By solving this equation for $P(M)$ we may obtain the value of the shunting mortality that results in equal expected utilities for *Wait* and *Shunt*, as a function of the probability of NPH ($P(NPH)$).

$$P(M) = 1 - \frac{U}{P(NPH) \cdot P(S) \cdot (1 - U) + U} \quad (25)$$

Normal pressure hydrocephalus

The syndrome of normal pressure hydrocephalus consists of dementia, gait abnormalities, with or without urinary incontinence, in the presence of a dilated ventricular system, and "normal" cerebrospinal fluid pressure.¹⁸⁰ In a large autopsy series of 164 pre-senile demented people 5.5% were diagnosed as normal pressure hydrocephalus.¹⁹² The diagnosis was based on the presence of severely dilated ventricles, thickened pia and arachnoidea, no pathologic evidence of Alzheimer's disease and no other cause for the ventricular enlargement. In 270 senile demented patients the frequency of NPH was 0.7%. The difference in relative incidence of NPH between senile and pre-senile demented patients²⁰⁸ may be explained by the large number of people with Alzheimer's disease at higher age.^{298,318}

Table 21. Prior probabilities of normal pressure hydrocephalus, multi-infarct dementia, intracranial space-occupying lesion and Alzheimer's disease.

	60 years		75 years	
	point value	plausible range	point value	plausible range
Normal pressure hydrocephalus (NPH)	5.5%	2.0%-9.0%	1.0%	0.0%-2.0%
Intracranial space-occupying lesion (SOL)	8.5%	4.5%-12.5%	4.0%	2.0%-8.0%
Multi-infarct dementia (MID)	15.0%	5.0%-45.0%	15.0%	5.0%-45.0%
Alzheimer's disease (AD)	<u>71.0%</u> +	33.5%-88.5%	<u>80.0%</u> ±	45.0%-93.0%
	100%		100%	

Many reports describe prognostic factors for successful shunting^{138,139,181,271,369} but in the majority of these reports the number of cases is small, follow-up short, the NPH syndrome loosely defined, criteria for success after shunting not explicit, and assessment of clinical status not independent of pre-operative status.^{10,157,208,180} As gait abnormalities will be criterion for inclusion in most of the studies, its frequency cannot be reliably estimated. In one large study of patients considered for shunting it occurred in 95%.²²² In studies where urinary incontinence was not a criterion for inclusion, this sign occurred in approximately 50% of patients.^{32,301,381} Slowness of thought and gesture are often mentioned. Focal signs are notably absent. Sometimes there are signs of cortico-spinal tract involvement. Extensor plantar responses have been found in 9 out of 16 patients,¹²⁰ and in 15 of the 74 patients in Larsson's study. Pseudo-bulbar signs, including primitive reflexes (snout, palmo-mental or grasp-reflex) were found in 70%.²²²

Intracranial space-occupying lesions

In a large autopsy study 4% of the senile demented patients had an intracranial space-occupying lesion, and a subdural haematoma was discovered in 1%.¹⁹² Of the pre-senile demented patients 8.5% had a space-occupying lesion and none had a chronic subdural haematoma (CSH). In non-demented patients aged less than 60 years CSH is not infrequent and the condition is well known for its frequent neuropsychological manifestations.⁴⁴ The absence of CSH in this age-group in the autopsy study has to be explained by the alertness of physicians that leads to surgical drainage before dementia develops. In demented patients with a cerebral space-occupying lesion, gait abnormalities are not uncommon. Fluctuations in the clinical course are may occur, because of edema or (focal) seizures.

Multi-infarct dementia

MID is a less common disorder than AD. The diagnostic term is used to designate dementia resulting from many large, cortical and subcortical infarcts and dementia resulting from small deep lacunar infarcts, which will not necessarily lead to similar clinical pictures.^{93,320} Estimates of the relative incidence of MID show wide variation.^{63,168,236} In estimating the relative incidence of multi-infarct dementia, many authors refer to Tomlinson.³⁷¹ The author himself states that his sample "was not truly a random one and consequently, conclusions could not be drawn about the prevalence of the various types of dementing processes in old age". Thus, the relative incidence of MID is taken at 15%, with a range of 5% to 45%.^{63,192,214}

In most studies the male to female ratio is 1:1.^{21,79} Common signs in MID are rigidity of the lower extremities, extensor plantar responses, gait abnormalities, and convulsions. We only found semi-quantitative estimates of the likelihood of these signs in the literature. Stepwise deterioration is noted as a typical feature of MID. History of stroke, which is common in MID, is not considered because it overlaps with stepwise deterioration. Signs of cortico-spinal tract involvement will be highly correlated, and therefore plantar responses only were considered. In a clinico-pathological study pseudo-bulbar signs and primitive reflexes occurred in 50%-90% and urinary incontinence in 85%.⁷⁹ However, it is quite likely that these clinical data were obtained late in the course of the disease, and therefore the frequency of these signs was estimated at 70% and 50%, respectively. In another study with pathological confirmation stepwise deterioration had occurred in approximately 50%, and focal signs were also noted in 50%.²⁷⁶ We decided not to use the complete (modified) Hachinski score,^{149,322} because it is not clear whether it is useful for discrimination of MID from other causes of dementia than Alzheimer's disease.^{117,168,192,275}

Alzheimer's disease

The prevalence of (Senile) Dementia of the Alzheimer Type in the elderly population has been estimated at 5-15%, making it the most frequent cause of dementia in the elderly. Its relative incidence in series of demented patients varies heavily, because the diagnosis is established "per exclusionem".

In an early stage the disease is characterized by amnesia, disturbances of spatial orientation and lack of spontaneity.²⁹⁸ The male to female ratio is 1:2.^{21,276,298} The duration of this stage is approximately 2 - 4 years. In his own series of more than 150 pre-senile demented patients people 20% had focal signs, predominantly dysphasia. Later, progressive dementia with typical focal features such as agnosia, apraxia and dysphasia, as well as urinary incontinence and gait difficulties develop.

Table 22. Feature probabilities of four possible causes of dementia (Normal pressure hydrocephalus (NPH), intracranial space-occupying lesion (SOL), multi-infarct dementia (MID) and Alzheimer's disease (AD). Estimates that are based on (adjusted) data from the literature are designated with ^L, estimates that are based on semi-quantitative information (from reviews mostly) are designated with ^R, and estimates that are entirely subjective are designated with ^S. For sources see text. Figures are rounded to the nearest 5%.

	NPH	SOL	MID	AD
Male gender	50% ^L	50% ^R	50% ^L	33% ^L
Stepwise deterioration	10% ^R	30% ^S	90% ^R	10% ^R
Gait abnormalities	95% ^L	50% ^S	50% ^R	5% ^L
Urinary incontinence	50% ^L	20% ^S	50% ^L	5% ^L
Dysphasia	5% ^L	10% ^S	25% ^R	25% ^L
Extensor plantar responses	25% ^L	50% ^S	50% ^L	5% ^R
Pseudo-bulbar signs	70% ^L	30% ^S	70% ^L	10% ^R
Focal abnormalities	5% ^R	60% ^S	50% ^R	5% ^R

Computed tomography

The sensitivity and specificity of CT investigation for several causes of dementia are determined and used to compute the probability of a treatable lesion when the CT results are known, and the overall probability of finding any treatable lesion by CT.

A diagnosis of probable Alzheimer type dementia is generally made after exclusion of other cerebral causes of dementia^{20,228} Intracranial space-occupying lesions will not be overlooked because they have to be rather large to cause global dementia. Artifacts are rare. Thus, both the sensitivity and specificity of CT for intracranial tumours that cause dementia will approach

100%. The aspect of the CT abnormalities seen in dementia ranges from mainly cortical atrophy to frank ventricular enlargement, as seen in NPH.¹³¹ The sensitivity of CT for NPH (defined as the chance that CT indicates hydrocephalus when the patient really suffers from NPH) is about 70% and the specificity (defined as 1 minus the chance that CT indicates hydrocephalus when the patient suffers from MID or AD) will be approximately 80%, when rigid criteria are applied. Tans' criteria for the CT-diagnosis of NPH in a study of 62 demented patients are based on LeMay's study: 1) absence of cortical atrophy, 2) and at least 2 of the following: a) frontal horn ratio > 0.50, b) width of third ventricle > 3.5 mm, c) width of fourth ventricle > 4.0 mm, d) periventricular lucencies, e) visibility of temporal horns. The final (gold standard) diagnosis was based on prolonged clinical observation.^{227,361}

Shunting for normal pressure hydrocephalus

Not even all patients with definite NPH respond favourably to shunting. This can be concluded from studies of patients with NPH secondary to subarachnoid hemorrhage, meningitis, and intracranial surgery, in which diagnosis is beyond doubt.²⁰⁸ Consequently, if secondary and idiopathic NPH have a comparable response to treatment, a measure of the expected success rate when the diagnosis of NPH is uncertain can be derived by combining the probability of NPH with the probability of successful shunting in patients with secondary NPH.

The decision to shunt depends on the likelihood of normal pressure hydrocephalus, the chance of successful shunting, and the risk of complications from shunting.^{10,157} Decision theory will be used weigh these risks and benefits in order to identify which type of patient may be considered for shunting. The decision tree depicts the decision to shunt a patient with an uncertain diagnosis of NPH, based on history, physical examination and on the results of CT. Shunting carries a risk of mortality ($P(M)$), resulting in death with a utility of 0. When the patient suffers from NPH (with a probability $P(NPH)$) and therapy is successful ($P(S)$), there will be lasting improvement of cognition. This outcome has a utility of 1. When shunting is not successful, or when the patient's disease is not NPH, she will remain in a state of slowly progressive dementia, with a utility value U . The strategy *do not shunt* implies that the patient will remain in a state of slowly progressive dementia, also with a utility value U . Values of U close to 0 imply that in the perception of a patient or his representative a large improvement can be made after successful shunting, and thus, they are more in favour of 'shunting' than values close to 1.

In decision theory utility is defined as equal to the substitution probability p when a decision maker is indifferent between an uncertain outlook $p \cdot 1; (1-p) \cdot 0$ with a chance p of the best outcome (lasting improvement of cognition and ambulation after shunting), valued 1, and a chance $(1-p)$ of the worst outcome (death), valued 0, on the one hand, and on the other a certain outlook of slowly progressive dementia with utility U . There are several methods to elicit utilities.³⁷⁴ We will by-pass this aspect by investigating a large range of values for U . However,

even when utilities are not assessed directly, they have an inherent, intuitive meaning. When $U = 0.75$ for example, this means that the patient is willing to take a mortality risk up to $1 - 0.75 = 0.25$, or 25%, in order to be relieved from her dementia when operation is certainly successful.^{393,396}

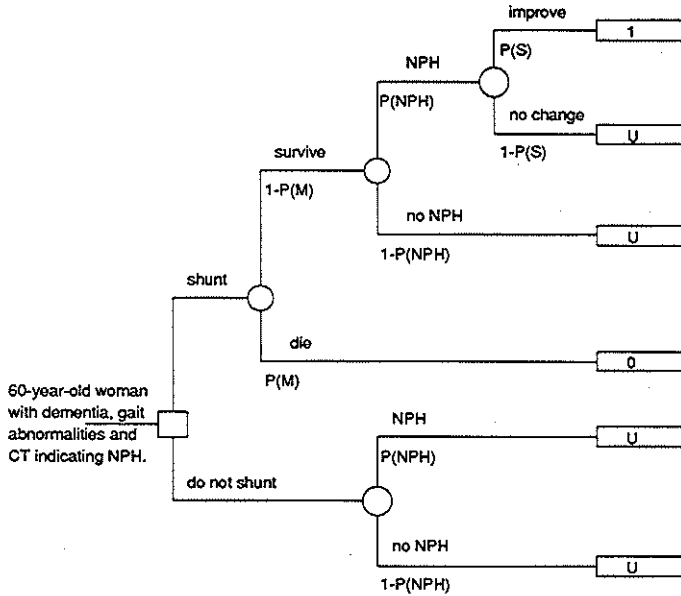

Figure 35. Decision tree for the shunting decision in patients whose CT indicates NPH. Square: decision node; Circles: chance node; rectangles: outcome node. Time flows from left to right.

The chances of success after shunting in secondary NPH equal about 67% with a plausible range of 60%-75%.^{35,208} Thus, the likelihood of successful shunting $P(S)$ in our patient will amount to 0.67 times the chance of NPH after a positive CT. In most recent studies, the mortality associated with shunting is 4%-9%,^{139,353,381,387} somewhat lower than in older studies. However, for the purpose of this analysis mortality of shunting $P(M)$ is taken at 10%, in order to avoid the effects of publication bias.³²⁸

8.2 Results

Diagnostic probabilities

The probability of NPH after history-taking and physical examination for the key patient amounts to 11%, see Table 23. In profiles 1 and 3 the absence of gait abnormalities decreases the likelihood of NPH considerably. The diagnostic probability of an intracranial space-occupying lesion in the key patient is 9%, and it ranges from 2% to 14% for the different clinical profiles. The probabilities of NPH when this condition is and is not suggested by CT, and the probability that the patient harbours any neurosurgically treatable lesion (a space-occupying lesion or NPH) and the CT shows it ($P(NPH \vee SOL, CT +)$), is also listed for each clinical profile.

Table 23. Diagnostic probabilities for the four clinical profiles of the four causes of dementia based on history and physical examination, and the probability of NPH, when the Computer Tomogram indicates such a lesion (CT+), and when it does not (CT-). The last column gives the probability that the CT rightfully indicates any treatable lesion (space-occupying lesion or NPH) on CT.

profile	Diagnostic probabilities				Probability of NPH after CT		Probability of a treatable lesion on CT
	NPH	SOL	MID	AD	$P(NPH CT +)$	$P(NPH CT -)$	$P(NPH \vee SOL, CT +)$
1	0.005	0.02	0.005	0.97	0.01	0.00	0.02
2	0.11	0.09	0.02	0.78	0.33	0.05	0.17
3	0.02	0.04	0.02	0.92	0.13	0.01	0.06
4	0.40	0.14	0.07	0.39	0.75	0.25	0.47

In Figure 36 an analysis of these results to plausible changes in the estimates is shown for the key patient. Changes in the prior probability of NPH and of gait abnormalities in Alzheimer's disease influence the diagnostic probability considerably.

In order to make generalizations to other clinical profiles, we constructed a diagnostic chart, using the log-odds form of Bayes' theorem (Figure 37).^c This chart allows one to estimate the likelihood of NPH in a certain patient, before and after CT. The effects of age on the diagnostic probabilities is also incorporated. In patients aged 75, the same ordering of the diagnostic probabilities as in profiles 1-4 emerges, but the probability of a treatable lesion is lower, and does not exceed 15%.

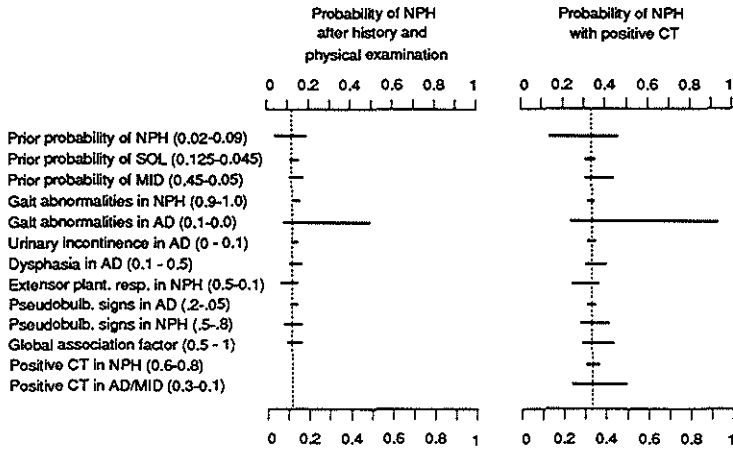

Figure 36. Analysis of the sensitivity of the probability of NPH after history and physical examination and after a positive CT to plausible changes in estimates. This figure relates to the key patient (profile 2). The baseline estimate is 0.11 and 0.33 respectively.

Diagnostic item	Score
Stepwise deterioration	- 10
Male gender	+ 5
Gait abnormalities	+ 44
Urinary incontinence	+ 18
Dysphasia	- 17
Extensor plant. resp.	+ 5
Pseudobulbar signs	+ 21
Focal signs	- 13
Age 60	- 70
Age 75	- 91
Total (add)	

Score	Odds	Probability
-90	1:512	0.002
-60	1:64	0.015
-40	1:16	0.059
-30	1:8	0.111
-20	1:4	0.20
-15	1:2.82	0.262
-10	1:2	0.33
-5	1:1.41	0.414
-2	1:1.15	0.465
-1	1:1.07	0.483
0	1:1	0.500
1	1.07:1	0.517
2	1.15:1	0.535
5	1.41:1	0.586
10	2:1	0.667
15	2.82:1	0.738
20	4:1	0.80
30	8:1	0.889
40	16:1	0.941
60	64:1	0.985
90	512:1	0.998

Figure 37. Algorithm for the probabilistic diagnosis of normal pressure hydrocephalus in demented patients. When a sign is present, the corresponding number indicated by the left-hand table should be added to a total score. The right-hand table is used to convert this score (10 times the logodds) via odds to probabilities. For every 10 points increase in total score, the odds for NPH double. To obtain the probability of NPH after a positive or negative CT, add 18 or -14 to the total score, respectively.

Decision analysis of shunting for NPH

In Figure 38 expected utilities of shunting and no shunting are computed for the key patient by "folding back" the decision tree. The difference between the two strategies is small, with a slight benefit for no shunting in the key patient.

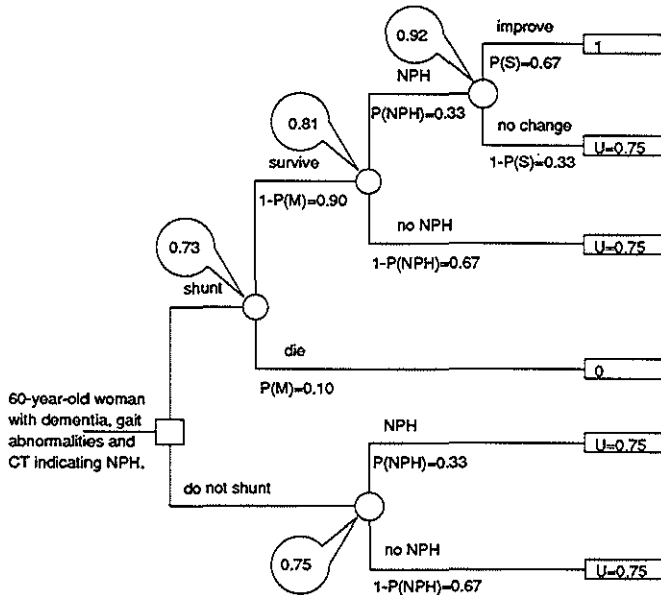

Figure 38. Decision tree for the shunting decision in patients whose CT indicates NPH. All probability- and utility-values that are applicable to patient 2 have been inserted. Folding back the tree results in an expected utility of 0.73 for shunting, and 0.75 for no shunting.

The decision tree is also evaluated using a threshold technique.²⁹⁷ Figure 39 shows which combinations of values for the mortality of shunting and the probability of success after shunting result in equal expected utilities for both treatment options. These threshold- or "break-even" lines are plotted for various levels of U , see also the methods section. This figure illustrates which patients will and which patients will not benefit from shunting, according to the expected utility criterion. For patients with profile 1 and 3 finding evidence for NPH on CT should not lead to shunting, even when the utility U of dementia is taken at 0.5 of the utility of recovery. For the key patient (profile 2) a clear-cut preference does not seem to exist in the

present analysis, but when the utility of dementia equals 0.5, shunting is preferred (see also the methods section for the interpretation of utility values). But for someone with a profile like patient 4 shunting seems to be beneficial. This conclusion is based on clinical information and CT results, but it may be modified by other prognostic test-results (e.g. conductance to outflow measurement, or external lumbar drainage).^{35,141,308,407}

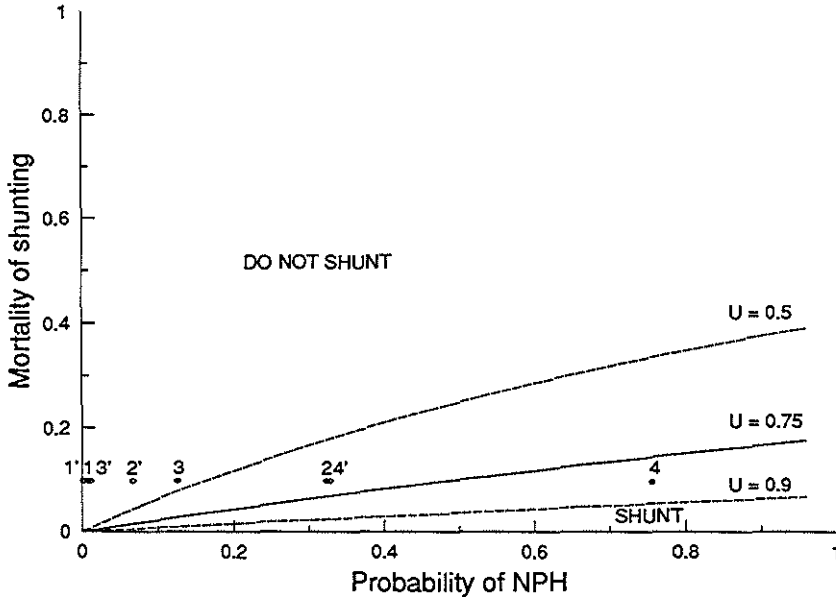

Figure 39. Break-even lines for the shunting decision in patients suspected of NPH. X-axis: probability of successful shunting in a patient whose CT indicates NPH. Y-axis: mortality of shunting. The lines depict the combinations of values that result in equal expected utilities for the "do not shunt" and "shunt" decision, for various levels of the utility of dementia, U . Below each threshold line shunting is preferred, above each line no shunting. Clinical profiles of 60-year-old patients are indicated by black dots numbered 1-4, and clinical profiles of 75-year-old patients by open dots numbered 1'-4'.

8.3 Discussion

We estimated the likelihood of NPH and intracranial space-occupying lesion in demented patients with a typical clinical profile. Based on these estimates, the chance of successful shunting for NPH was assessed. Decision analysis was used to weigh the risks and benefits of shunting in each patient.

This paper is based on the scientific evidence that is currently available. Where information is sparse, conclusions of a decision analysis can only be tentative. This does not imply that a quantitative approach should be abandoned, but rather that the analysis has been useful in identifying areas of clinical knowledge that would (if expanded) contribute much to better decision making in dementia. Particularly, estimates of the relative incidence of Alzheimer's disease and related disorders, and of the frequency of diagnostic signs and symptoms are seldom reported in the literature. The data in this analysis seemed reasonable estimates to the authors when they considered the scarce evidence. This means that the results of this study should be applied to other patients with skill and caution.

The analysis has a normal cerebrospinal fluid pressure as a fixed assumption. This does not mean that patients are required to undergo a lumbar puncture before its results can be consulted. On the contrary, our tables and figures help surveying the clinical situation that will exist in the -likely- event that the pressure is normal. In this way, they contribute to the decision whether or not a CT or any other major diagnostic procedure is worthwhile.

Our method of analysis has its limitations: In the computations we used binary tests (indicating absence or presence of a sign or symptom). We did not allow for intermediate observations. Also, diagnostic features do not occur independently. This will influence the reliability of the computed values, if no corrections are made. We have tried to overcome these problems by sensitivity analyses and by using a global association factor. It is clear that we have chosen for maximum simplicity. In our opinion, taking more diagnostic features into consideration would not add much to the usefulness of the model because these feature probabilities would even be harder to quantify and dependence between features would become a greater problem. For the same reason, we did not include entities as Binswanger's disease and demented patients with periventricular white matter hypodensity in the analysis.

Our analysis helps in distinguishing between patients who are likely to benefit from shunting and those who are not. The threshold approach suggests that only a relatively young patient with dementia of recent onset, the full triad of symptoms and CT evidence of NPH should be considered for shunting, if no additional prognostic information is available. For a patient of older age with the full triad and for a 60-year-old patient with only gait abnormalities and dementia a toss-up situation exists. More prognostic information might be of importance for these patients. Obviously, for the other patients, the finding of ventricular enlargement on CT - suggesting NPH - should not have any consequences.

Results of other prognostic tests may be of value, especially for patients with a profile like the key patient. When a patient improves in cognition or gait after a diagnostic lumbar puncture, the chances of successful shunting are high, but this phenomenon is rare, and when there is no clinical effect successful shunting is still quite likely.³⁰⁸ Conductance to outflow measurement may be of value. However, the results of the group of Børgesen have not been reproduced by

others.^{35,138} Moreover, the additional prognostic value of this test over more easily obtainable clinical information is not clear. The same argument holds for external lumbar drainage and continuous pressure monitoring. To our knowledge, the value of both tests has never been assessed in a prospective, independent study. SPECT scanning may render useful information, but its prognostic value is suggested in one study only.¹³⁸

Our general recommendations will not surprise those who have followed or participated in the discussion of the management of NPH in the literature. However, the recommendations from our decision model have a rational basis. The assumptions are easy to identify and are open for discussion. Estimates can be adjusted to personal insight and to the results of other prognostic tests, and the consequences of these changes can easily be assessed. Moreover, application of the model leads to a more individualized decision, which takes patient characteristics into account in a controlled way.

The analysis can be helpful in comparing the value of pieces of diagnostic information. For example, the absence of gait abnormalities in a demented patient is important; it makes normal pressure hydrocephalus an unlikely diagnosis. When interpreting a CT of a such patient one should be aware that NPH and successful shunting remain unlikely, even when hydrocephalus appears to be present.

Dietch observed that in dementia patients without special features the rate of treatable lesions is very small.⁸¹ Vanneste already emphasized the importance of clinical signs for the prognosis after shunting in NPH patients. In his retrospective follow-up study, the proportion of patients with permanent overall improvement in the categories with 'probable', 'possible' and 'improbable' normal pressure hydrocephalus according to a global clinical/CT scale was 65%, 15% and 13%, respectively.³⁸⁸ However, clinical and CT criteria were informally weighed and lumped together in one scale, making more detailed conclusions impossible.

In our opinion more information on the specificity of clinical signs such as gait abnormalities, urinary incontinence, slowness and apathy in Alzheimer's disease and related disorders is needed.

In the diagnostic and therapeutic management of a dementia patient the clinician has to rely on experience and intuition to manage the large amount of information that arises from clinical findings, knowledge, and the literature. We do not suggest that our approach should be used instead of the approved methods of clinical reasoning. But we think that we have shown that a formal, quantitative approach is useful in the differential diagnosis and management of dementia patients.

Notes

a. This chapter is adapted from: Dippel DWJ, Habbema JDF. Probabilistic diagnosis of normal pressure hydrocephalus and other treatable cerebral lesions in dementia. *J Neurol Sci.* In press.

- b. These subjective estimates were challenged by a senior researcher in clinical decision theory with special interest in the neurosciences, by a senior neurologist with long academic experience, and by an academically trained neurosurgeon.*
- c. Because of rounding, and because we took the weighted average of the diagnostic probabilities for the other causes of dementia, the results are accurate by approximately 5%.*

Chapter 9

Individualized prognosis in subarachnoid haemorrhage^a

Patients with subarachnoid haemorrhage have a poor prognosis. The three-month mortality after admission to hospital is about 40%,¹⁶⁹ and varies with patient selection.^{256,293} Part of the mortality can be attributed to the initial haemorrhage, but rebleeding and cerebral infarction also take a heavy toll.

Medical and surgical interventions have always aimed at prevention of the complications from subarachnoid haemorrhage. However, there is a lack of consensus about major aspects of the medical and surgical management. Medical treatment options consist of antifibrinolytics (tranexamic acid (TEA)) to reduce the rate of rebleeding, and calcium antagonists (nimodipine) to prevent infarction. However, a favourable effect of tranexamic acid could not be demonstrated in a controlled study,²⁰² nor in a randomized controlled trial.³⁸⁹ The rate of rebleeding in the tranexamic acid branch of both studies was significantly reduced, but the rate of infarction was increased. The authors concluded that "...for patients to benefit from antifibrinolytic therapy, the complications of treatment must be minimized while the ability to prevent rebleeding is preserved".³⁸⁹ Surgical treatment involves clipping of the aneurysm responsible for the haemorrhage. Early surgery will prevent most rebleeds, at the expense of a risk of surgical mortality. Delaying surgery until day 10-12 will decrease surgical mortality, but cannot prevent early rebleeds.

All treatment options affect rebleeding and infarction risks. Patient-oriented decision making should thus depend on individualized estimates of the risks of rebleeding and infarction. We will derive such estimates from a re-analysis of the data of the randomized clinical trial of tranexamic acid against placebo.³⁸⁹ The effect of newer modifications of treatment (i.e. nimodipine³⁰⁷ and management of hyponatremia¹⁵⁹) on outcome will be assessed.

In the next chapter, the results presented here will be used for a decision analysis of best combinations of medical and surgical strategies for subarachnoid haemorrhage patients, including the timing of surgery.

9.1 Material and methods

The original study was a randomized, placebo-controlled double blind clinical trial. Of the 479 study-patients with subarachnoid haemorrhage that occurred within 72 hours, 210 were admitted to the Neurological Department of Dijkzigt Hospital Rotterdam, 23 to the Neurological Department of the Academisch Medisch Centrum in Amsterdam, 217 to the Neurosurgical Department of the Southern General Hospital in Glasgow, and 29 to the Neurosurgical Department of the Royal Free Hospital in London. In total, 904 patients with subarachnoid haemorrhage were seen in the four centres during the study period, thus, 47% were excluded,

mainly because of a lapse of more than 72 hours between bleeding and admission (205 patients), a cause for subarachnoid haemorrhage obviously other than aneurysm (87 patients), death within a few hours in a moribund patient (55 patients), and (emergency) operation within 72 hours from bleeding (51 patients). For a detailed description of the trial protocol see the original publication.³⁶⁹ A few years after the conclusion of the trial and the publication of its results, the CT's made within 48 hours from admission were re-analyzed and graded according to the amount of subarachnoid blood, intraventricular blood and severity of hydrocephalus, because other studies had demonstrated the value of CT's in predicting infarction and poor outcome.^{3,119,171}

The CT's of the 29 patients in the London branch of the trial were not available for re-analysis. Therefore, these patients are excluded, leaving 450 patients. In our analysis, only the patients with a CT diagnosis of subarachnoid haemorrhage (blood visible in basal cisterns/fissures) or with a clinical diagnosis of subarachnoid haemorrhage with a positive angiogram within four days from admission are included. Forty-five patients did not fulfil these criteria of inclusion. Of the remaining 405 patients, 67 did not have their CT re-analyzed, because further investigations did not reveal an aneurysm. This group is not excluded, but considered separately, because the present study has a pragmatic viewpoint, as it concerns prognosis and decision making at the time of admission (= inclusion in the study) in patients with possibly aneurysmal subarachnoid haemorrhage.

Clinical variables

As the results of this study should aid in decision making early after admission to the hospital, only the clinical information that is available at admission is considered.

The medical history was taken with systematic recording of the time that had elapsed between the haemorrhage and admission to the hospital, complaints of headache and the occurrence of seizures or loss of consciousness at the time of the haemorrhage. A full neurological examination was carried out on admission to hospital. The level of consciousness at admission was classified according to the 14 point Glasgow Coma Scale.³⁶² The presence of neck stiffness, urinary incontinence, speech abnormalities, retinal abnormalities (subhyaloid haemorrhage or papilledema), pupil abnormalities and limb weakness was noted.

Hydrocephalus on CT was defined as a bicaudate index greater than the 95th percentile for age.¹⁷⁰ Patients were graded according to the amount of subarachnoid blood on CT by assigning a score to each fissure or cistern according to its filling grade (0 = no blood, 1 = small, 2 = moderate, and 3 = large amount of blood). A sumscore was created by adding up the scores for the cisterns. Cisterns that were not visible on CT were assigned the average value based on the other cisterns. Similarly, the amount of blood in each ventricle was also scored (0 = no blood, 1 = sedimentation, 2 = partly, 3 = completely filled with blood), and a sumscore was created. For a detailed description of the grading of the amount of blood on CT see Hijdra.¹⁷⁰

For the present analysis, most clinical variables are recoded from three- or five-point scales to two-point (0=absent/1=present) scales: *Age* (55 or less; over 55), *Hunt and Hess' score* (I,II; III-V), *Glasgow coma score* (12-14; < 12), *Amount of subarachnoid blood* (0-9; 10 or more), *Amount of intraventricular blood* (0-2; 3 or more). Cut-off scores were determined by clinical usefulness and reproducibility,²³³ but otherwise by the median. Absent (0) refers for all variables to the prognostically most favourable category.

Events and health outcome

Events such as death, rebleeding and infarction occurring within 1 month, and the health outcome at 3 months were recorded. Definite rebleeding was defined as sudden deterioration with increased haemorrhage, confirmed by CT or autopsy when compared to a previous CT, and possible rebleeding as sudden deterioration and death, without the possibility of proof by CT scan or autopsy. The diagnosis of definite infarction was made when the patient gradually developed focal signs or deteriorated in conscious level, with infarction confirmed by a CT scan or autopsy. Infarction was deemed possible when the patient gradually developed focal signs only, without CT confirmation. In our re-analysis, the "possible" and "definite" categories are combined. The health outcome after 3 months was classified according to the Glasgow Outcome Scale,¹⁹³ consisting of the categories death or persistent vegetative state; severe disability; moderate disability; and full recovery.

Statistical analysis

The statistical analysis consisted of four steps. First, univariate analyses with one sided χ^2 significance tests are used to identify potential prognostic factors.²⁷⁴ One-sided significance tests are used, except for the variables *sex*, *delay (of admission)* and for the effect of treatment on three-month mortality, because in these cases the direction of the effect is not known beforehand. Proportional hazards regression with stepwise forward selection assesses the impact of these variables on the occurrence of rebleeding, infarction and mortality from the initial haemorrhage in the presence of other prognostic factors.^{62,200,226,87} The selected variables are called prognostic factors. The risks of rebleeding, infarction and mortality in the 67 patients who did not have their CT analysed because another cause of the subarachnoid haemorrhage became evident during hospitalization, did not differ significantly from the base-line hazard. It is conceivable that these patients would have minor abnormalities on CT. Therefore, they were included in the low risk group of the "CT-variables" in the regression analysis.

Cox' proportional hazards model with stepwise forward selection of variables is used to assess the prognostic value of clinical variables in a multivariate framework over time. In this model the hazard rate (the instantaneous risk or incidence density at time t) of each event m (rebleeding, infarction, mortality from the initial haemorrhage and three-month mortality) for the n^{th} individual, is expressed as a multivariate function (containing p variables x_i) of the base-line hazard function $h_m(t)$:

$$\hat{h}_{m,n}(t) = h_m(t) \cdot \exp\left(\sum_{i=1}^p \beta_{m,i} x_{m,i}\right) \quad (26)$$

Thus, for each individual or subgroup that is characterized by a unique combination of values for certain variables, the hazard rate $\hat{h}_{m,n}(t)$ is proportional to the base-line hazard $h_m(t)$.^{62,226} The selection of variables for the regression equation is based on statistically significant changes in maximized partial likelihood ($p < 0.05$, one sided) with and without the variable that is considered.⁸⁷ The proportionality assumption is checked by stratifying the study-population by each variable and plotting $\ln(-\ln \hat{S}_m(t))$ against time for mean values of the other covariates.²⁰⁰ These plots are not presented here for reasons of space, but no gross violations of the proportionality assumption were encountered.

Proportional hazards regression analysis can be used to estimate the relative risk RR (the ratio of incidence densities of the exposed and non-exposed with regard to event m) from a certain item of diagnostic information $x_{m,j}$, controlled for other prognostic factors:

$$RR \approx \exp(\beta_{m,j} \cdot x_{m,j}), \quad (27)$$

because the risk profile with $x_{m,j} = 0$ is assigned to patients who are in the best prognostic category, this gives $RR = 1$. Also, the parameters can be used to estimate for the n^{th} patient the cumulative probability $P_{m,n}(t)$ of event m until day t , based on the available clinical information:

$$\hat{P}_{m,n}(t) = 1 - \hat{S}_{m,n}(t) = 1 - \hat{S}_m(t)^{\exp\left(\sum_{i=1}^p \beta_{m,i} x_{m,i}\right)}. \quad (28)$$

In the third step, the event probabilities are brought in a competing risks model to compute the three-month mortality, which is expressed as a function of rebleeding and infarction risks and their lethality, and of mortality from the initial haemorrhage, and - indirectly - of treatment choice. The competing risks model combines mortalities from rebleeding, infarction and the initial haemorrhage. Data for rebleeding and infarction are obtained by multiplying by proportional hazards calculated probabilities with the lethality of rebleeding and infarction. The lethality of rebleeding and infarction are estimated using a minimum χ^2 -parameterization²⁷⁷ of the risks of mortality from the initial haemorrhage, from rebleeding and infarction and their lethality, that allows two independently occurring events and assumes that the lethalties are not affected by treatment with tranexamic acid. In this way, an individualized estimate of the

prognosis after subarachnoid haemorrhage is presented. Finally, the impact of the prognostic factors on the difference in three-month-mortality is estimated, and presented in a chart that is easy to use in a clinical setting.

9.2 Results

Table 24 lists the clinical characteristics of the study population. There are some imbalances between the two treatment groups. More patients in the placebo branch of the study had an angiogram showing an intracranial aneurysm and eventually underwent surgery. This table also shows the results of univariate analyses. For each variable it is indicated whether a statistically significant relation exists with three-month mortality (O), mortality from the initial haemorrhage (M), and the occurrence of infarction (I) and rebleeding (R). All clinical variables are associated with three-month mortality, except *headache*, *seizures at the ictus*, *neck stiffness*, *history of hypertension*, and *cardiovascular history*. The signs and symptoms that are associated with infarction are generally not associated with rebleeding, but *loss of consciousness at the ictus* is an exception to this rule; it is the only variable that is related to rebleeding in the univariate analyses, apart from tranexamic acid.

Table 24. Clinical characteristics of the study population by type of treatment, and their relation with three-month mortality, mortality from the initial haemorrhage, and the occurrence of rebleeding and infarction. O = Overall (three-month) mortality, M = mortality from the initial haemorrhage, R = rebleeding, I = infarction (+ = statistically significant relation, . = no statistically significant relation ($p = 0.05$, one sided χ^2)). † indicates a statistically significant difference ($p < 0.05$ two sided χ^2) between the placebo and tranexamic acid group.

	Placebo (N=202)		tranexamic acid (N=203)		relation with outcome			
	No	perc.	No	perc.	O	M	R	I
Age					+	+	.	.
<36	31	15%	31	15%				
36-45	38	19%	38	19%				
46-55	52	26%	58	29%				
56-65	62	31%	40	20%				
>65	19	9%	36	17%				
Sex				
female	125	62%	122	60%				
modified Hunt & Hess score					+	+	.	.
I-II	103	51%	116	57%				
III	63	31%	52	25%				
IV-V	36	18%	35	17%				
Glasgow coma score					+	+	.	.
3-11	102	50%	110	54%				
12,13	62	31%	53	26%				
14	38	19%	40	20%				
Medical history								
History of hypertension	50	25%	33	16%†
Cardiovascular history	9	5%	21	10%	.	.	.	+

(To be continued on next page.)

(Continued.) Clinical characteristics of the study population.

	Placebo (N=202)	tranexamic acid (N=203)	relation with outcome			
Signs and symptoms						
Loss of consciousness at the ictus	102 51%	97 48%	+	.	+	+
Seizures at the ictus	23 11%	20 10%
Headache	176 87%	174 86%
Incontinence	49 24%	51 25%	+	.	.	+
Neck Stiffness (moderate-severe)	144 71%	150 74%
Speech abnormalities	17 8%	9 4%	+	.	.	.
Retinal abnormalities	44 22%	43 21%	+	.	.	+
Pupil abnormalities	13 6%	15 7%	+	+	.	.
Limb weakness	32 16%	25 12%	+	+	.	.
Computed Tomography						
Subarachnoid blood					+	+
0-9	79 39%	62 31%			.	.
10-19	58 29%	52 25%			.	.
20-30	41 20%	46 23%			.	.
missing values	24 12%	43 21%			.	.
Intraventricular blood					+	.
0-2	137 68%	111 55%			.	.
3-12	41 20%	49 24%			.	.
missing values	24 12%	43 21%			.	.
Haematoma	51 26%	53 27%			+	+
missing values	2 1%	3 2%			.	.
Hydrocephalus	36 18%	36 18%			+	.
missing values	27 13%	45 22%			.	+
Angiography						
negative	14 7%	28 14%†				
intracranial aneurysm	149 74%	119 59%				
not done	39 19%	56 27%				
Surgery						
	106 53%	86 42%†				

Table 25 lists the results for each treatment group. Tranexamic acid reduces the risk of rebleeding by 13.8% (0.90 CI=8.2%-19.4%) but it increases the risk of infarction by 8.3% (0.90 CI=1.5%-15.1%). The difference in three-month mortality (2.5%, 0.95 CI=-6.9%-12.1%) is slightly in favour of tranexamic acid. It is larger when patients in persistent vegetative state are included with the deaths (4.1%, 0.95 CI = -5.4% - 13.4%). Fifty-two percent of the patients who had an

infarction, 84% of those who had a rebleeding, and only 23% of those who had neither event died. The lethality of rebleeding and infarction, and the mortality from the initial haemorrhage are all somewhat lower in the placebo group, but this is not statistically significant.

Table 25. Overall results in the placebo and the tranexamic acid group: rebleeding and infarction occurring within 1 month, and the three-month health outcome.

	Tranexamic acid (N=203)	Placebo (N=202)
Events		
Rebleeding (lethality)	7.4% (86.7%)	21.3% (83.7%)
Infarction (lethality)	26.7% (53.7%)	18.3% (48.7%)
Health outcome		
Persistent vegetative state	0.0%	1.5%
Severe disability	13.9%	9.9%
Moderate disability	10.9%	9.4%
Well	38.1%	39.6%
Mortality		
from rebleeding	6.4%	17.8%
from infarction	14.4%	8.9%
from the initial haemorrhage	16.3%	12.9%
Mortality from any cause	<u>37.1%</u> ±	<u>39.6%</u> ±
	100.0%	100.0%

Prognostic factors

Table 26 summarizes the results of the proportional hazards regression analysis with stepwise forward selection of prognostic factors. Tranexamic acid is not only a prognostic factor for rebleeding and infarction, but it also increases the mortality from the initial haemorrhage. The relative risk (rate ratio) of rebleeding and infarction for patients treated with tranexamic acid, corrected for the effect of other significant prognostic factors is 0.3 and 1.5, respectively. This is consistent with the observed risks in this trial, where the risk of rebleeding is reduced from 21.3% to 7.4%, for an uncorrected relative risk of 0.34.

Figures 40a-c show the risks of infarction, rebleeding and the mortality from the initial haemorrhage for the minimum hazard patient and for a patient with values of 1 for *loss of consciousness at the ictus* (LCI) and *amount of subarachnoid blood >9* (SAB), who is treated with placebo or with tranexamic acid. Note how the favourable effect of tranexamic acid on rebleeding is counteracted by the risk of mortality from the initial haemorrhage and infarction.

Table 26. Proportional hazards model; Stepwise selection of variables and the associated rate ratio i.e. the ratio of the hazard with and without the symptom. Variables are listed in order of selection.

Step	Variable	Rate Ratio (90% Confidence Interval)
Infarction		
1	Amount of subarachnoid blood on CT >9 (SAB)	1.9 (1.3-2.8)
2	Retinal abnormalities (RET)	1.9 (1.3-2.8)
3	Amount of intraventricular blood on CT >2 (IVB)	1.6 (1.0-2.4)
4	Treatment with tranexamic acid (TEA)	1.5 (1.0-2.1)
5	Glasgow coma score <12 (GCS)	1.8 (1.2-2.8)
Rebleeding		
1	Treatment with tranexamic acid (TEA)	0.3 (0.2-0.5)
2	Loss of consciousness at the ictus (LCI)	2.1 (1.3-3.3)
3	Amount of intraventricular blood on CT >2 (IVB)	1.8 (1.2-2.8)
Mortality from the initial haemorrhage		
1	Glasgow coma score < 12 (GCS)	5.3 (2.8-9.8)
2	Amount of subarachnoid blood on CT >9 (SAB)	3.4 (1.7-7.2)
3	Treatment with tranexamic acid (TEA)	2.1 (1.1-4.1)
4	Age >55 (AGE)	2.2 (1.2-4.2)

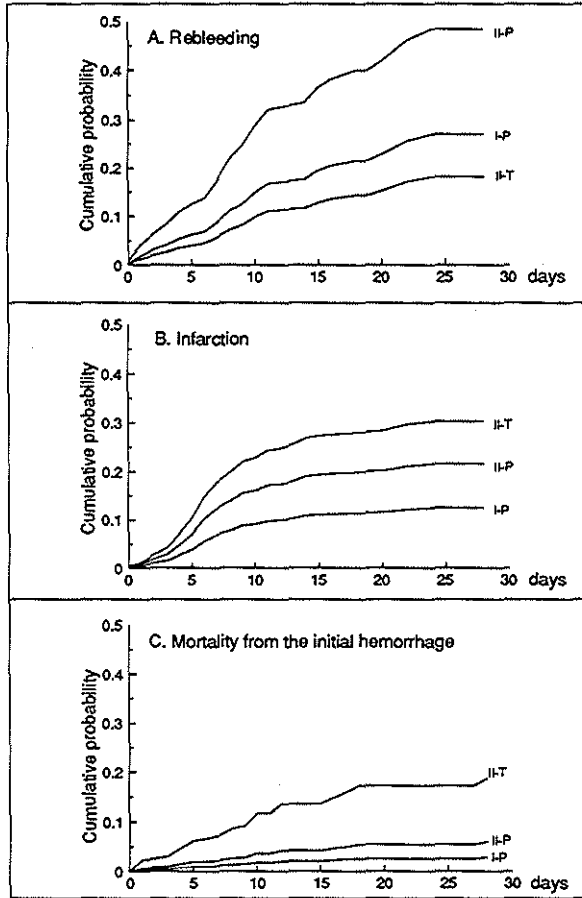

Figure 40. Cumulative probabilities of rebleeding, infarction and mortality from the initial haemorrhage for the minimum hazard patient, not treated (curve I-P) and for a patient with loss of consciousness at the ictus and amount of subarachnoid blood >9, treated (I-T) and not treated (I-P) with tranexamic acid. Each graph has the number of days since admission on the X-axis, and the cumulative probability on the Y-axis.

Clinical profiles and treatment effects

In order to get a better insight into the relation between overall mortality, clinical signs at admission and the complications from subarachnoid haemorrhage, we used the competing

risks model described in the methods section to compute the three-month mortality with and without tranexamic acid, as a function of the risks of rebleeding, infarction and mortality from the initial haemorrhage for each clinical profile.

In order to find out if interaction between the effect of tranexamic acid on three-month mortality and the two main prognostic factors for rebleeding and infarction exists, a separate proportional hazards regression model for overall mortality with four prognostic factors was constructed: *Glasgow coma score* <12 (GCS, RR=2.5, 90% CI 1.8-3.5), *amount of subarachnoid blood on CT* >9 (SAB RR=1.7, 90% CI 1.2-2.5), *loss of consciousness at the ictus* (LCI, RR=1.8, 90% CI 1.3-2.6), and *Age* >55 (AGE, RR=1.5, 90% CI 1.0-2.0). Along with tranexamic acid (TEA, RR=0.5, 90% CI 0.3-0.9) a factor TEA*SAB (RR 2.4, 90% CI 1.2-4.8) could be included. This interaction factor implies that for patients with a large amount of subarachnoid blood on CT (SAB=1) TEA increases the mortality risk, but for a patient with a small amount of subarachnoid blood on CT the mortality is decreased by tranexamic acid. Adding a factor LCI*TEA did not result in a statistically significant improvement of the model.

Figure 41 shows the rebleeding and infarction chances and the estimated mortality according to the competing risks model for each clinical profile. A tree structure illustrates how the study population can be ordered according to the values for individual prognostic factors. The three-month mortality ranges from below 20% to over 80%. In order to approximate the natural history of subarachnoid haemorrhage, it is assumed that surgery does not take place. Infarction risks are adjusted for the effects of modern fluid management, see further below. The prognostic factors that make up the clinical profiles were ranked according to the impact they have on the mortality difference between the treatment groups. The most common profiles (N>10) have unfavourable values for not more than one prognostic factor.

Table 27 shows the expected three-month mortality for the whole study population, when all individualized estimates of the competing risks model are averaged. When surgery does not take place (regime D), the risks of rebleeding will be higher than observed in the study-population. As a consequence, the three-month mortality will also be higher, and the mortality improvement due to tranexamic acid will be greater. Without surgery, the expected three-month mortality with tranexamic acid is even smaller than was observed in the study population. However, surgery is used as a censoring variable, and some patients have undergone emergency operation.

In regime II the expected three-month mortality is computed as if 47.4% of the total study population (conform the observed proportion averaged for the two treatment groups) will undergo operation. This results in mortality differences between placebo and tranexamic acid as observed in the study population, but the expected three-month mortalities are 5% lower, because surgical mortality (i.e. the risk of mortality of any kind after being operated) is not

Individualized prognosis in subarachnoid haemorrhage

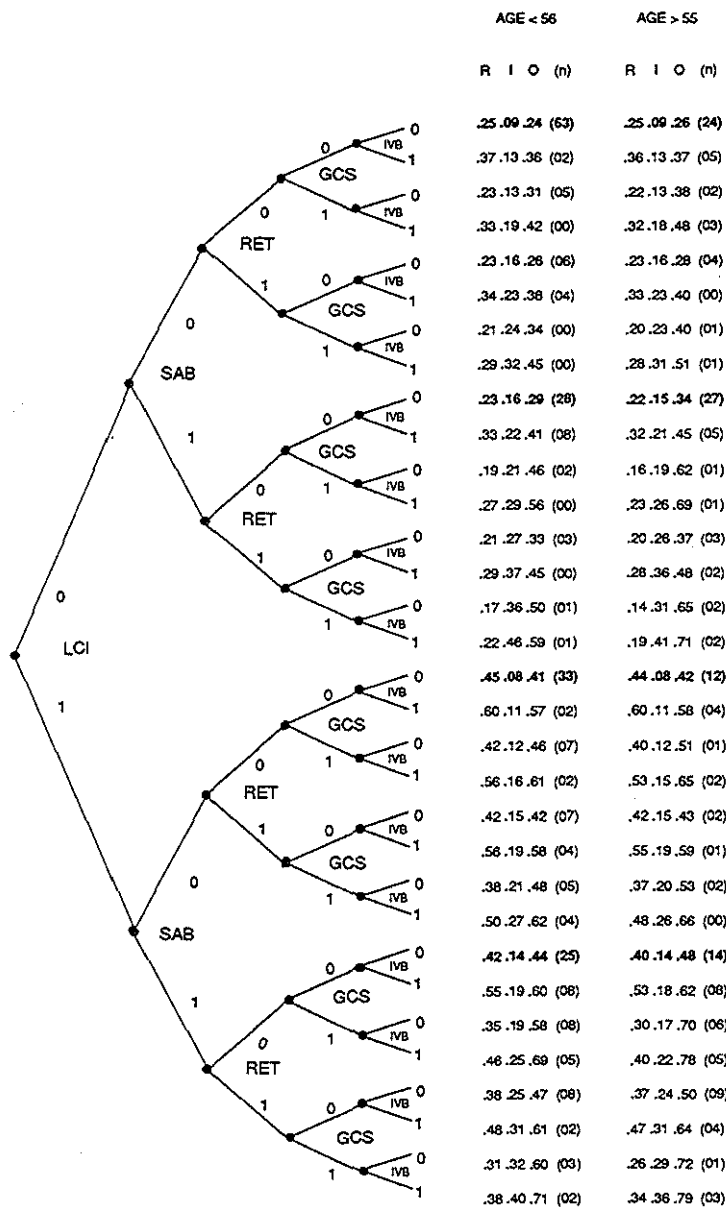

Legend of Figure 41. Estimated risks of rebleeding (R), infarction (I) and three-month mortality (M) for each clinical profile, without tranexamic acid or surgical treatment but with adjustment for the effect of modern fluid management. The tree structure illustrates how clinical profiles are determined by absence (upper branches, 0) or presence (lower branches, 1) of each symptom. The number of patients with each profile is listed under (N). Bold text indicates more common (N>10) clinical profiles. For example, a patient with clinical profile 0→1→0→1→0 has a rebleeding and infarction risk of 29% and 37% respectively when treated with placebo, and a 45% 3-month mortality.

taken into account. Taking the surgical mortality at 11% (on average) for patients who are operated in both treatment groups results in the three-month mortality rates that are equal to those observed in the study population.

Table 27. Competing risks model. Differences in three-month mortality between tranexamic acid and placebo for three clinical management regimes: I no surgery at all, II Surgery at day 10, and III surgery at day 10 with "modern management". For further explanation see the Results section.

Regime	Assumptions	tranexamic acid	placebo	Difference
I	No surgery			
a	"baseline"	34.3%	41.5%	7.2%
b	"modern fluid management"	33.2%	40.8%	7.6%
II	Surgery			
a	no surgical mortality	32.0%	34.4%	2.4%
b	surgical mortality = 11%	37.0%	39.4%	2.4%
III	Surgery and "modern management"			
a	"modern fluid management"	35.9%	38.7%	2.8%
b	"modern fluid management" and nimodipine	34.2%	37.2%	3.0%

Nimodipine reduces the rate of infarctions by approximately 34%.³⁰⁷ In a recent study hypertension was treated only when the patient received prior medication, and fluid intake was not restricted, in order to prevent infarctions.^{159,406} The rate of infarction was 10% instead of the expected 20%. However, this study had no experimental design. Moreover, in the placebo branch of the British Nimodipine study, where no fluid restriction was employed, the rate of infarctions is even higher than in the placebo branch of the tranexamic acid trial, and the rate of fatal infarctions is about equal.^{307,389} The effect of the changes in fluid-management and management of hypertension is incorporated by adjusting the regression estimates of infarction risk in model II-b according to the weighted mean of Hasan¹⁵⁹ and our data. This implies a

reduction in infarction risk by $1 - ((1 - .34) \times 0.81) = 46\%$, when the effects of nimodipine and hypertension and fluid management are independent. The three-month mortality is decreased by 2.2% in the placebo group and by 2.8% in the tranexamic acid group, and the mortality difference is increased by 0.6% in favour of tranexamic acid (0.4% by modern fluid management and 0.2% by nimodipine).

Figure 42 is a prognostic chart that depicts the impact of presence or absence of prognostic factors on the effect of tranexamic acid. It is assumed that each patient is scheduled for delayed surgery as in regime III. The estimates are based on a linear regression of the prognostic factors, where the difference in three-month mortality has to be predicted. The fit of the model is excellent ($r^2=0.95$, $p<0.00005$, standard deviation of residues 1.6%).

Three-month mortality difference (TEA - placebo) for patients with subarachnoid hemorrhage admitted within 72 hrs and scheduled for surgery on day 10-12	
Loss of consciousness at the ictus	- 8%
Amount of subarachnoid blood on CT >9	+ 7%
Retinal abnormalities	+ 1%
Glasgow coma score <12	+ 12%
Amount of intraventricular blood on CT >2	- 5%
Age >55	+ 4%
Constant	- 7%
Mortality difference	(Add:)

Figure 42. Difference in three-month mortality between tranexamic acid and placebo determined by the presence or absence of prognostic variables for rebleeding and infarction. The patient is scheduled for surgery on day 10-12 and receives modern medical management. Example 1: Tranexamic acid treatment in patient who satisfies none of the criteria decreases the risk of mortality after subarachnoid haemorrhage by 7%. Example 2: Treatment with tranexamic acid increases the mortality in a patient who has not lost consciousness at the ictus, with a Glasgow coma score of 11, no retinal abnormalities, and a substantial amount of subarachnoid, but virtually no intraventricular blood on CT, by 12%.

9.3 Discussion

We have used proportional hazards regression to investigate the effect of clinical variables on the risk of rebleeding, infarction and mortality from the initial haemorrhage. A competing risks model computes the three-month mortality as a function of the risks and lethality of rebleeding and infarction, and of the mortality from the initial haemorrhage. Then, the effect of the prognostic factors for rebleeding, infarction and mortality from the initial haemorrhage on the difference in mortality between placebo and tranexamic acid has been presented.

Methodological aspects

Our approach to modelling the clinical course of subarachnoid haemorrhage and the effect of tranexamic acid via prognostic factors for "intermediate events" is justified and clinically relevant, because all treatments for subarachnoid haemorrhage act through modification of the risk of rebleeding and infarction.

The results of any predictive model should be interpreted with care. An area of concern is the external validity of the study. The observations described here date from several years hence. CT scans have improved technically, but not to such an extent that this considerably influences the diagnosis of rebleeding or infarction after subarachnoid haemorrhage. The medical management of subarachnoid haemorrhage has changed, but adjustments for fluid management and treatment with nimodipine³⁰⁷ have been made. The regression models have not yet been tested on an independent sample. As is apparent from many reports, the base-line prognosis after subarachnoid haemorrhage differs from centre to centre. Before use, each centre would require to carefully consider the necessity of calibrating the models for the local situation.

Our study is not an ordinary retrospective subgroup analysis which scrutinizes the data for all kinds of modifications of the treatment effect. In this study we have tested the hypothesis that patients with a different risk profile for the complications of subarachnoid haemorrhage will be affected differently by tranexamic acid.¹³² The highly variable prognosis of patients with subarachnoid haemorrhage was already recognized as an argument for such an effect-modification. Moreover, the investigators who conducted the study already considered the possibility of effect modification, but they used less sensitive methods (i.e. logistic regression). Still, one requires caution in individualizing treatment effects within a 'negative' clinical trial.³⁰⁸ However, there were in this case 'a priori' clinical arguments for interaction between the tranexamic acid effect on mortality and predictors of rebleeding and infarction. A welcome side effect of the regression analysis is that it allows us to make consistent estimates of risks for clinical profiles that have not been observed in the trial.

A side-issue is that we used the observed mortality difference (2.5%) as the best estimate of the treatment effect. In a classical statistical approach one might argue that the null-hypothesis of "no treatment effect" is not rejected, and that therefore a zero mortality difference should be assumed.³⁰² However, the difference is small.

Previous studies

Other studies have also reported on the role of computed tomography in overall prognosis and in predicting infarctions in patients with aneurysmal SAH.^{3,47,171,372} These studies had a more explanatory than a pragmatic, decision-oriented character. For example, in the studies of Brouwers⁴⁷ and Hijdra,¹⁷¹ patients with a cause of the SAH other than a ruptured aneurysm were excluded from the analysis. In the latter study, clinical variables other than Hunt & Hess' grade and the Glasgow Coma score were not considered.

Our results confirm previous work identifying the amount of subarachnoid and intraventricular blood as important predictors of infarction.^{3,47,169} Surprisingly, retinal abnormalities (comprising both subhyaloid haemorrhage and papilledema) also seem to be important independent predictors of infarction. Vanderlinden suggested a relationship between the occurrence of subhyaloid haemorrhage and sudden increased intracranial pressure in four cases of SAH, in whom these signs occurred after episodes of rebleeding.³⁸⁶ In an older series of 75 patients with SAH, the demonstration of subhyaloid haemorrhages seemed important prognostically, for 14 out of 23 patients with subhyaloid haemorrhage died, compared to 14 out of 52 without this sign ($p < 0.01$, χ^2).²⁵¹ Retinal abnormalities may relate to the severity and/or duration of the rise in intracranial pressure, occurring during aneurysm rupture and may represent a dynamic factor that is not covered by SAB and IVB.

In previous studies using a reliable definition of rebleeding, treatment with tranexamic acid was the only prognostic factor associated with rebleeding. Hasan found that patients with hydrocephalus who had extracranial drainage had a significantly higher risk of rebleeding. They noted that these patients underwent operation less often, but they did not adjust for longer exposure time.¹⁶⁰ We found two other factors related to the occurrence of rebleeding: *loss of consciousness at the ictus* and *amount of intraventricular blood* >2 . Both may again indicate the dynamics of the SAH, perhaps representing the size of the breach in the fundus of the aneurysm.

Conclusions

We conclude that the occurrence of rebleeding after subarachnoid haemorrhage relates to loss of consciousness at the ictus and to the presence of intraventricular blood. No other studies have demonstrated such a relationship. We have confirmed that the amount of subarachnoid and intraventricular blood on CT, and the Glasgow coma score are valuable, independent predictors of the occurrence of infarction. Other studies have already shown the reliability of these factors.^{170,406} Infarction also seems to be related to the presence of retinal abnormalities. This factor has not been considered in previous studies.

Tranexamic acid increases the mortality risks of patients with a large amount of subarachnoid blood on their initial CT, and it decreases the mortality risks of patients with a small load of blood and a high risk of rebleeding. This conclusion is supported by clinical knowledge, the results of our competing risks model, and was confirmed by a statistically significant interaction between amount of subarachnoid blood on CT and tranexamic acid in the regression model for three-month mortality. The predictions from our competing risks model were condensed into a prognostic chart.

Tranexamic acid seems to relate to mortality from the initial haemorrhage in the proportional hazards regression analysis, although this did not appear in the univariate analyses. Perhaps some of the mortality after the initial haemorrhage was in fact caused by ischaemia,

making our observation the result of difficulties with classification. Age is not a predictor of rebleeding or infarction, but it is associated with a higher mortality, thus representing a higher vulnerability of the elderly, see also Muizelaar.²⁷⁹

Our results can aid clinical practice. The prognostic factors are all easy to determine from clinical examination and from computed tomography. They can be used in assessing individual prognosis. Moreover, if operation is not planned within the first few days, the information can indicate which patients should, and which should not be treated with tranexamic acid.

Further research

We are aware that proof of the effects that are described in this analysis can only be obtained by conducting another experimental study, comparing modern subarachnoid haemorrhage management alone with modern subarachnoid haemorrhage management and tranexamic acid. Our study may be helpful in identifying the right target population for such a trial.

Interestingly, the type of patient that may benefit from treatment with tranexamic acid is also likely to benefit from (early) surgical treatment. Surgery is primarily aimed at prevention of rebleeding, and its risks are, like treatment with tranexamic acid, greater for patients who are at high risk of infarction. Only a very large randomized clinical trial may perhaps determine whether for certain patients a combination of medical therapies (probably including nimodipine) with postponement of surgery to day 10-14, should be preferred over early surgical treatment.

Clinical decision analysis²¹⁶ is an alternative approach to comparing many complicated management strategies, using sound estimates of risks and treatment effects. This study serves as a framework on which to base such an approach, integrating knowledge from different sources. The results of the decision analysis will be published in the next chapter.

Notes

a. This chapter is adapted from: Dippel DWJ, Van Crevel H, Lindsay KW, Hijdra A, Habbema JDF. Management of subarachnoid hemorrhage: Individualized prognosis. Submitted for publication.

Chapter 10

Management of subarachnoid haemorrhage^a

Subarachnoid hemorrhage is most often the result of rupture of an arterial intracranial aneurysm, close to the circle of Willis. Even when patients survive the initial hemorrhage and remain in good condition, the risk of deterioration from recurrent hemorrhage and brain ischemia or infarction is high.

Surgical treatment is aimed at occluding the aneurysm from the circulation before rebleeding occurs. Early surgery on day 1-3 after subarachnoid hemorrhage has been advocated in order to minimize the rebleed risk. Early surgery is more hazardous than delayed surgery (on day 10-12), because the brain is tight and swollen, and the risk of vasospasm and infarction is increased. Yet excellent management results have been reported by several authors.^{333,359} Delayed surgery is less effective than early surgery, because fewer patients will reach operation. Because of its relative safety, it is the treatment of choice among many neurosurgeons.²⁰⁴

All medical treatment options act to decrease the potential complications from subarachnoid hemorrhage. Antifibrinolytics (tranexamic acid or TEA) reduce the risk of rebleeding, but increase the risk of infarction.^{202,389} There is no empirical proof of a beneficial effect of antifibrinolytics on outcome after subarachnoid hemorrhage. We showed in the previous chapter that antifibrinolytics may be used in selected patients with low infarction risks. It may be used as an alternative to operation in the first few months, or it may serve to bridge the dangerous period between admission to hospital and delayed surgery on day 10-12. Nimodipine, a calcium antagonist, reduces the risk of infarction both in pre- and post-operative patients with subarachnoid hemorrhage, and it appears to remain free of major side-effects.³⁰⁷ A high fluid intake and plasma volume expansion seems to be beneficial in patients at risk of ischemia.¹⁵⁹ Fludrocortisone acetate is commonly used to reduce salt wasting in patients with subarachnoid hemorrhage. Hyponatremia is associated with the occurrence of infarction, but a beneficial effect of fludrocortisone acetate on infarction risk or overall outcome has not been established.^{158,406}

There is no consensus with regard to the use of antifibrinolytics and to the timing of aneurysm surgery after subarachnoid hemorrhage.^{122,215,252,383,390,401} Moreover, it is unlikely that a single treatment strategy is best for all patients, with widely differing prognoses. Randomized trials comparing more than two medical regimes and/or different policies on the timing of surgery do not seem feasible. Only one large non-randomized comparative study has been carried out,^{203,204} and one rather small randomized study,²⁸⁹ both with inconclusive results.

A clinical decision analysis approach, using the best available, individualized estimates of risks and benefits of each treatment may be the best method to overcome the problems mentioned above. In the previous chapter, a re-analysis of a randomized clinical trial of tranexamic acid, an antifibrinolytic agent, we described the risks of rebleeding, infarction and mortality from the initial hemorrhage as multivariate time-dependent functions of clinical variables, using proportional hazards regression. These estimates will be used in the decision analysis that is presented in this paper.

The following actions are considered in the analysis: *Early surgery (on day 2) (ES)*, *delayed surgery (on day 10) (DS)*, *late elective surgery (after three months) (LS)* and medication with *nimodipine (N)*, and *antifibrinolytics (AF)*. Reasonable combinations of these actions result in the following strategies:

- I No special actions.
- II Late elective surgery only (LS).
- III Nimodipine and late elective surgery (N, LS).
- IV Nimodipine and antifibrinolytics and late elective surgery (N, AF, LS).
- V Early surgery, nimodipine and late elective surgery (ES, N, LS).
- VI Delayed surgery, nimodipine and late elective surgery (DS, N, LS).
- VII Delayed surgery, nimodipine, antifibrinolytics and late elective surgery (DS, N, AF, LS).

The first two strategies in which no action is undertaken during the first three months are included for reference. The decision analysis model allows for other values for the day of surgery, but the discussion is focussed on day 2 and day 10. Late elective surgery is an option in strategies III-VII, because some patients will not be suitable candidates for surgery on the planned day, and surgery will have to be postponed. It is important to consider this option in the analysis, because it influences the attractiveness of non-surgical therapies compared to surgical strategies for the management of subarachnoid hemorrhage. Patients will of course receive optimum symptomatic treatment, including fluid intake of at least 3 litres, plasma volume expansion when there are signs of delayed cerebral ischemia and CSF drainage for treatment of hydrocephalus.^{159,160}

10.1 Material and methods

Patients

Five patients, who cover a wide range of clinical profiles will be considered in this analysis. Clinical profiles consist of combinations of prognostic factors for rebleeding, infarction and mortality from the initial hemorrhage, that have been identified in the previous chapter. Table 28 lists the clinical characteristics of all five patients, and their risks of rebleeding, infarction and mortality. Patient 3 will serve as a key patient to illustrate the analysis. She is a 45-year-old

woman who has been admitted to hospital within 48 hours after the onset of a severe sudden headache. She did not lose consciousness at the time of the initial hemorrhage. The patient scored 11 points on the 14-point Glasgow coma scale (E2 M5 V4).³⁶² Neurological examination revealed no focal deficits and there were no retinal abnormalities, but there was some nuchal rigidity. Computed tomography showed a rather large amount of subarachnoid blood in the basal cisterns (>8 points) and virtually no intraventricular blood (<3 points), see also Hijdra.¹⁷⁰ According to the prognostic system described in our previous work, this patient would have a risk of rebleeding and infarction of 19% and 21% respectively and a three-month mortality rate of 46%, if treated symptomatically.

Table 28. Patient characteristics, one-month probabilities of rebleeding and infarction without further treatment, and three-month mortality rates based on the re-analysis of the tranexamic acid-trial. For each prognostic factor letters indicate whether it is related to rebleeding (R), infarction (I) or mortality from the initial hemorrhage (M). '+' means factor present, '-' means factor absent.

	Patient				
	1	2	3	4	5
Sex	F	F	F	F	F
Age (M)	45	45	45	45	65
Glasgow Coma Score <12 (IM)	-	-	+	+	+
Loss of consciousness at the ictus (R)	-	+	-	-	-
Retinal abnormalities (I)	-	-	-	+	+
Subarachnoid blood on CT >9 (IM)	-	-	+	+	+
Intraventricular blood on CT >2 (Ri)	-	-	-	+	+
One-month rate of rebleeding	.25	.45	.19	.22	.19
One-month rate of infarction	.09	.08	.21	.46	.41
Three-month mortality rate	.24	.41	.46	.60	.72

Decision tree

In a clinical decision analysis, alternative strategies consisting of one or more actions are considered. These were already listed in the introduction. The strategies can be illustrated by a decision tree (Figure 43).

The decision for *surgical treatment* (early or delayed) is represented in the upper part of the tree. Surgery will be carried out when the patient harbours an accessible aneurysm according to the cerebral angiogram and is in a stable clinical condition. For simplicity, the possibility of another cause for the subarachnoid hemorrhage than an aneurysm is excluded. Surgery will prevent any further rebleeding, but it is associated with mortality and morbidity.

With *medical treatment*, there is a risk of death from the initial hemorrhage and risks of rebleeding and infarction. After surviving the first rebleed or infarct, there may be a second event.

When the patient is still alive after three months, she will be in one of the health states Well, Moderate disability or Severe disability as described in the Glasgow Outcome Scale.¹⁹³ The persistent vegetative state is not considered in view of its rarity after subarachnoid hemorrhage.^{203,169} The probabilities of these outcomes depend on the clinical state of the patient at the time of entry to hospital, the number of rebleeds and infarcts, and the occurrence of complications after surgery. After three months, the patient is assumed to remain in her health state for the rest of her life. It may be worthwhile to clip the aneurysm if surgery has not yet taken place, to prevent late rebleeding.³⁸² Severely disabled patients have a reduced life expectancy, and will not undergo late elective surgery.

The decision tree is for illustrative purposes only. In the actual computational model (written in Pascal),³⁶ we first compute the one-month probabilities of rebleeding and infarction, the three-month mortality and probabilities of health states at three months. A life table approach with daily competing risks of rebleeding, infarction and mortality is used. This part of the analysis is directly based on the proportional hazards regression estimates from Chapter 9. Confidence limits for the individualized estimates of rebleeding, infarction and mortality after subarachnoid hemorrhage are estimated according to Tsiatis³⁷⁷ with modifications by Christensen.⁶¹ The life expectancy and the time spent in each health state is computed for each treatment modality, using life table estimates and estimates of the long term risk of rebleeding. Preferences for health outcomes and time are considered by using discounted quality adjusted life expectancy (dQALE) as a proxy for the expected utility (see also the results section). The strategy with the highest dQALE should be considered as good advice. The robustness of the analysis is assessed by sensitivity analysis, i.e. by testing how sensitive the optimum decision is to changes in estimates within the plausible range. For a more detailed description of decision analysis techniques see.^{142,206,216,396}

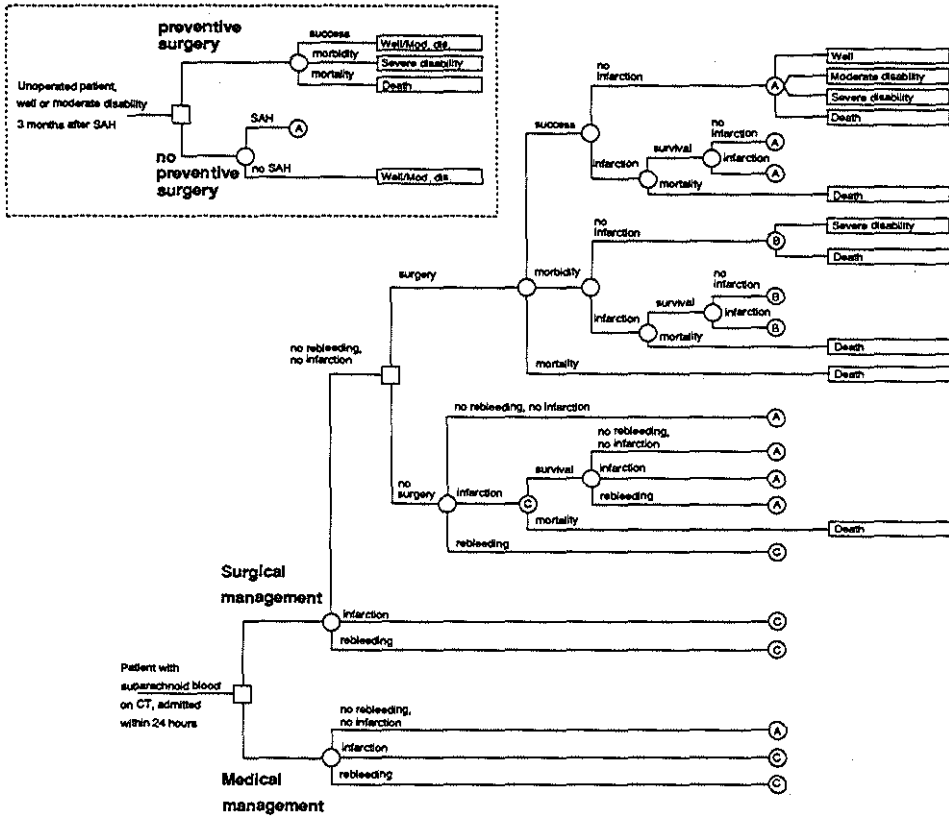

Figure 43. Decision tree for the management of patients with subarachnoid hemorrhage. The upper part of the tree depicts surgical management (strategies V, VI and VII) and the lower part medical management (strategies I-IV). Squares represent decision nodes, circles chance nodes, and rectangles health outcomes. For both parts of the tree the probability values may differ according to the chosen strategy. Letters at the end of a branch ending in a chance node refer to identical subtree structures. The option of late elective surgery (strategy II, LS) is represented in the dotted rectangle.

Available data and estimates

In this section, we summarize data from a comprehensive review of the literature. Point values and plausible ranges with estimated 90% confidence bounds will be suggested in the text below, and are listed in Table 29.

Table 29. Probability estimates for the decision analysis of subarachnoid hemorrhage management. For sources see "Available data and estimates".

		Point value	Plausible range	
Natural history of subarachnoid hemorrhage				
Severe disability after the initial hemorrhage		.15	.10-.20	
Moderate disability after the initial hemorrhage		.17	.12-.22	
Lethality of rebleeding		.75	.65-.85	
Severe disability after non-fatal rebleeding		.53	.22-.84	
Moderate disability after non-fatal rebleeding		.09	.00-.25	
Lethality of infarction		.32	.24-.40	
Severe disability after non-fatal infarction		.18	.06-.30	
Moderate disability after non-fatal infarction		.25	.11-.39	
Annual rate of rebleeding (1st year)		.06	.04-.08	
Annual rate of rebleeding (10th year)		.03	.02-.04	
Mortality of late rebleeding		.65	.50-.80	
Severe disability after non-fatal late rebleeding		.50	.25-.75	
Annual excess mortality from severe disability		.05	.025-.1	
Medical treatment				
RR of infarction with nimodipine		.66	.45-.87	
RR of rebleeding with antifibrinolytics		.30	.20-.50	
RR of infarction with antifibrinolytics		1.50	1.00-2.10	
RR of mortality from the initial hemorrhage with antifibrinolytics		2.10	1.60-7.00	
Surgical treatment				
	Patient 1 & 2	Patient 3 & 4	Patient 5	
Mortality of late elective surgery	.02	.01-.04	.02	.01-.04
Morbidity of late elective surgery	.06	.02-.10	.06	.02-.10
Mortality of delayed surgery	.05	.03-.07	.07	.04-.10
Morbidity of delayed surgery	.09	.07-.11	.11	.08-.14
Mortality of early surgery	.08	.04-.11	.12	.06-.18
Morbidity of early surgery	.12	.09-.15	.16	.11-.21
RR of infarction after surgery	2.0	1.0-3.0	2.0	1.0-3.0

Natural history and medical treatment of subarachnoid hemorrhage

Causes of deterioration and death after subarachnoid hemorrhage have been divided into three categories: rebleeding, infarction and the effects of the initial hemorrhage (i.e. acute ischaemic damage, late hydrocephalus and extracranial complications). The estimation of these risks from the data of the tranexamic acid-trial has been described in the previous chapter.

The data from this trial suggest that approximately 80% of the patients who do not suffer a rebleeding or infarction, survive. Of these, 15% and 17% remain severely and moderately disabled after three months. The lethality of rebleeding, adjusted for other causes of death, has been estimated at 75%. A large proportion of those who survive the recurrent hemorrhage, will remain severely disabled. The lethality of infarction is less than half that of rebleeding, and the risks of moderate and severe disability are also lower.

Several years after the conclusion of the tranexamic acid-trial, the management of patients with subarachnoid hemorrhage has been modified from fluid restriction (Rotterdam) or no fluid expansion (Glasgow) to fluid expansion and to anti-hypertensive medication only on strict indication, i.e. only when the patient was already on treatment for hypertension before the subarachnoid hemorrhage occurred. The one-month rate of infarction in Rotterdam was considerably lower under the modified management regime.¹⁵⁹ In Chapter 9 we described how we adjusted the rate of infarction for this effect to 0.8 times the risk in the time that the antifibrinolytics trial was conducted. This adjustment is also used in the present study.

The relative risk of rebleeding in patients on antifibrinolytics is 0.3 (0.2-0.5), adjusted for other significant prognostic factors in the proportional hazards regression model. This beneficial effect of antifibrinolytics is counteracted by an increased risk of infarction; the relative risk is 1.5 (1.0-2.1). The effect of antifibrinolytics was further counteracted by an increase in mortality from the initial hemorrhage, with a relative risk of 2.1 (1.1-4.0).

In the British nimodipine study³⁰⁷ a relative risk of fatal and non-fatal infarctions of 0.66 (0.45-0.87) was observed in the nimodipine group. (In their article, the authors reported the effect of nimodipine as a rate difference of 34% (0.90 CI: 13%-55%.) No modification of the effect of nimodipine by important risk factors for infarction was found. Others have reached similar conclusions.^{6,188,264,288,305}

The long term risk of rebleeding was estimated from Winn,^{409,410} i.e. 6% annually in the first year after the subarachnoid hemorrhage, decreasing to 3% after nine years. The mortality of late rebleeding is estimated at 65% and the risk of severe disability after non-fatal late rebleeding at 50%.⁴⁰⁹

Long term survival was modelled according to the Dutch life tables of 1985.⁵⁶ An annual excess mortality rate of 5% (0-10%) is assumed for patients in the state "severe disability".

Surgical treatment

Surgery has a strongly preventive effect on rebleeding. It will be preceded by angiography, for confirmation and localization of the aneurysm. In some patients, angiography will fail to reveal an aneurysm, because the aneurysm is just not detected by the procedure, or an effective clot has sealed the remains of the aneurysm from the circulation. (Patients with perimesencephalic hemorrhage have already been excluded from the analysis.³¹⁷) Of the 405 patients in the re-analysis of the tranexamic acid-trial, 42 (10%) had a negative angiogram, and

angiography was not performed in 95 patients (23%), but 36 of these patients had an autopsy, revealing an aneurysm in 33. We estimate that of the patients like 1-4 who had not yet suffered a rebleed or infarction on the day of surgery, 75% (60%-90%) will actually undergo operation, compared to 50% (25%-75%) of the older patients like 5, who are more likely to deteriorate after the subarachnoid hemorrhage.

Surgery carries a risk of mortality and morbidity. Some have reported excellent results of early surgery,^{333,359,65} but the non-randomized "Cooperative study on the timing of aneurysm surgery" suggests that there is no clear cut case for delayed or early surgery.²⁰⁴ A statistically significant difference between the management mortalities for alert patients in the "early" and "delayed" surgery groups (11% and 13% respectively) was not observed in this study, but the mortality rates in the 4-6 days-, and 7-10 days planned surgery intervals were higher (17% and 15% respectively). Unfortunately, only combined rates of death and disability were reported. Events that caused disability before or after surgery were not distinguished. Moreover, estimates of the mortality that is attributable to surgery have to rely on the classification of the authors, but no definitions or methods for classification are given.

In the clinical literature the term surgical mortality is used to describe the probability of death from any cause after a certain time-period in operated patients. In this analysis, it is defined as the mortality that is attributable to surgery. This makes trade-offs between benefits and risks of surgery possible.

In order to estimate the mortality and morbidity from acute aneurysm surgery, we used the multivariate prognostic model that is described in Chapter 9 to compute the expected mortality from the initial subarachnoid hemorrhage and from infarction in the 174 patients from the tranexamic acid-trial that had elective aneurysm surgery. The average time-span between admission and surgery was 10 days. The difference between the observed mortality (Kaplan Meier estimate) and the expected mortality (computed with proportional hazards regression estimates) amounts to 13.4%-7.8% = 5.6%. This is a good estimate of the mortality that is attributable to surgery in patients who are in good pre-operative condition. Of the 174 subjects, 159 had a Glasgow coma score greater than 11 at admission. The risk of infarction after surgery was increased, but not statistically significant.

In the present analysis, surgical risks are broken down into those basic to the procedure itself (the basic surgical mortality) and those associated with technical difficulties related to the patient's condition, the amount of blood surrounding the aneurysm and the tightness of the brain (the excess surgical mortality). The basic surgical mortality is presumed equal to the risks of late elective surgery and to the risks of surgery of unruptured aneurysms,³⁸² i.e. 0.02 (0.01-0.04). The excess surgical mortality is taken at 0.03 (0.01-0.06) for delayed surgery in patients 1 & 2, and at 0.05 for delayed surgery in patients 3 & 4. These risks are taken two times (1.5-3 times) higher for early surgery. The mortality from delayed surgery $P(mds)$ is estimated

by adding the excess mortality $P(em)$ to the basic mortality $P(bm)$, i.e. $P(mds) = P(bm) + P(em)$. The mortality from early surgery $P(mes)$ is estimated by adding 2 (1.5-3) times the excess mortality to the basic mortality: $P(mes) = P(bm) + 2 \cdot P(em)$. Thus, the mortality from early surgery relates to the mortality from delayed surgery as follows: $P(mes) = P(bm) + 2 \cdot (P(mds) - P(bm))$. Delayed surgery for the key patient has a mortality risk of 0.07 (0.04-0.10) and early surgery has a risk of 0.12 (.07-.17). The relative risk of infarction after surgery is taken at 2 (1-3).²⁰⁴

10.2 Results

In this section, the results of the analysis for the key patient (nr 3) will be presented. Then, sensitivity analyses will be used to test the "robustness" of the results for the key patient against plausible changes in estimates. Next, the results for the other four patients will be outlined. At last, early surgery will be considered in more detail.

Base-case analysis: key patient

Table 30 summarizes the results for the key patient (patient 3). "No specific treatment" would lead to lower rates of infarction than at the time of the tranexamic acid-trial, because the fluid management has since changed.¹⁵⁹ The risk of rebleeding is slightly higher, because more patients remain at risk. Nimodipine treatment (III, N, LS) reduces the risk of infarction even more. The other treatment strategies lead to a reduced risk of rebleeding, with delayed surgery (strategy VI, DS, N, LS) as the least effective in this regard. These strategies also lead to an increased infarction risk. Whether the increase in infarction risks is compensated by the reduced rebleeding risks, depends on the severity of both complications. Figure 44 shows how the cumulative rebleeding and infarctions risks are changed by surgical interventions.

Table 30. Results of the decision analysis for the key patient (patient 3). The cumulative risks of rebleeding and infarction after one month (A), the cumulative three-month probabilities of being in different health states (B), the number of life years spent without, with moderate, and with severe disability (C) and the life expectancy proper (LE), with quality adjustment (QALE) and quality adjustment and discounting (dQALE) (D). The best strategy and its closest contenders are underlined. Normal life expectancy for a Dutch woman of 45 equals 35.7 years, and the dQALE without morbidity and mortality from subarachnoid hemorrhage would be 15.8 years.

	Strategy						
	I	II LS	III N,LS	IV N,AF,LS	V ES,N,LS	VI DS,N,LS	VII DS,N,AF,LS
A. Complications							
Rebleeding	.19	.19	.20	.05	.07	.14	.04
Infarction	.21	.21	.15	.20	.22	.17	.22
B. Three-month health outcome							
Well	.34	.34	.35	.29	.32	.33	.25
Moderate Disability	.09	.09	.09	.07	.08	.08	.07
Severe Disability	.11	.11	.11	.08	.16	.14	.11
Death	.46	.46	.45	.55	.44	.44	.57
C. Life years spent							
Well	7.2	10.8	11.4	9.3	11.0	11.6	8.7
Moderate disability	1.9	2.9	2.8	2.4	2.9	2.9	2.3
Severe disability	1.8	1.7	1.7	1.3	2.5	2.2	1.6
D. Life expectancy							
unadjusted LE	11.0	15.3	<u>15.9</u>	13.0	<u>16.4</u>	<u>16.6</u>	12.7
quality adjusted LE	10.4	14.8	<u>15.3</u>	12.5	<u>15.7</u>	<u>15.9</u>	12.2
discounted QALE	5.5	6.9	<u>7.2</u>	5.9	<u>7.4</u>	<u>7.5</u>	5.7

When the three month health outcome is considered, treatment with antifibrinolytics is associated with a substantially higher mortality. However, the three month mortality in itself is not an adequate decision criterion, because the risks of severe and moderate disability after three months are different for each strategy. Therefore, we computed the probabilities of each health state after three months. For the key patient, the chance of being WELL is largest with conservative treatment without antifibrinolytics (strategy III, N, LS), but the mortality risk is lowest with early and delayed surgery (strategies V (ES, N, LS) and VI (DS, N, LS)). Clearly, the utility of intermediate health states is important. Also, the remaining life expectancy is important because the long term risk of rebleeding depends on it.

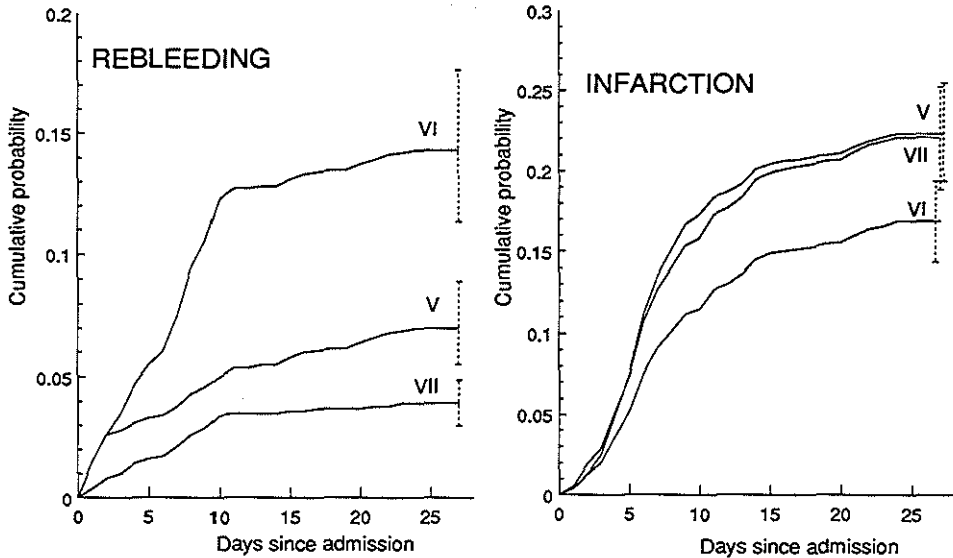

Figure 44. Cumulative risks of rebleeding and infarction as a function of time (days from admission), for the key patient ($n=3$), with early surgery (strategy V, ES,N,LS), delayed surgery without (strategy VI, DS,N,LS) and with antifibrinolytics (strategy VII DS,N,AF,LS). Ninety percent confidence intervals are indicated by vertical lines at the end of each curve.

The previous table also lists the expected number of life years lived in each health state for the key patient, per strategy. Added up, these figures give the total life expectancy for each strategy. Health status is taken into account by assigning utilities to each outcome, on a scale 0 (Death) to 1 (Well). Moderate disability is assigned a value of 0.95 (0.91-0.99) and severe disability 0.75 (0.625-0.875). By multiplying the life years spent in each health state with their respective utility, a quality-adjusted life expectancy (QALE) is computed. However, most people attach more value to nearby life years than to life years far away in the future. Therefore, 5% (0%-10%) annually will be discounted.²⁶² In the remainder of this paper, outcomes will be given in discounted QALE (dQALE).

When the key patient is treated only symptomatically (I), she would have a dQALE of 5.5 years. Late elective surgery (II) would increase this to 6.9 years. The reduction in rate of infarction by nimodipine (III) adds another benefit of 0.6 life year, or 0.3 discounted quality adjusted life years. Adding antifibrinolytics (IV, VII) to the regimen is clearly not a good choice

for this patient. Early surgery (V) for patients in good condition reduces the risk of rebleeding, but, because of the associated risks, the added benefit is no more than 0.2 discounted quality adjusted life years. For the key patient, delayed surgery when possible, with nimodipine (VI, DS,N,LS), offers a better balance between risks and benefits (0.1 discounted quality adjusted life year extra).

Sensitivity analyses

First we examined the effects of uncertainty in the estimates on the best strategies (i.e. early surgery (V, ES,N,LS) and delayed surgery (VI, DS,N,LS) for the key patient. Figure 45 shows parameters that have a relatively large effect on the difference in dQALY between strategy V (ES, N,LS) and VI (DS, N, LS). The most important one is the excess mortality due to early surgery: when it is low, early surgery is preferred and when it is high, delayed surgery. Also, a high risk of rebleeding, and a low risk of infarction after surgery favour early surgery. Plausible changes in some of the other estimates do not have a large effect on the difference between the strategies, although they may be quite uncertain or imprecise, because they appear in both strategies.

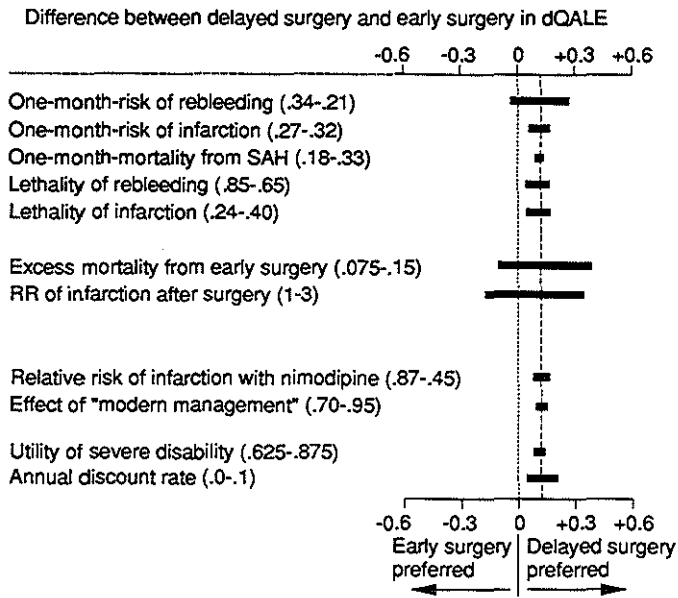

Figure 45. Sensitivity analyses for the key patient (nr 3). The effect of plausible changes in estimated probabilities and patient preferences on the differences in dQALE between delayed surgery (strategy VI, DS,N,LS) and early surgery (strategy V, ES,N,LS). The dotted line indicates a zero difference in discounted quality adjusted life expectancy between the strategies. In the base-case analysis that uses the point values, the difference is 0.11 discounted quality adjusted life years, indicated by a dashed line. When the difference is negative, early surgery is preferred.

Other patients

Table 31 shows the results of the analysis for all 5 patients, in discounted QALE. For patients 1 and 2 strategies with antifibrinolytics yield a higher dQALE, because the increase in mortality and infarction rate is relatively low, compared to the large effect on the rebleed rate. For these patients the benefit of delayed surgery over late elective surgery is almost nil, because the risk of rebleeding with antifibrinolytics is very small. For patient 4 either early or delayed surgery (without antifibrinolytics) has the largest benefit. Patient 5 has the worst prognosis. For her, the highest dQALE is attained by strategies III (N, LS) and VI (DS, N, LS). Planning surgery for such a patient does not affect the prognosis much, because the chance of actually undergoing surgery and surviving it, is only 0.09 (0.04-0.14) according to the decision model. However,

this analysis takes the time of admission as the decision point. The situation is different when patient 5 is alive and a reasonably good candidate for surgery on day 10. In that situation, surgery is indicated.

Table 31. Results of the decision analysis for all five patients in dQALE. The best strategy and its closest contenders are underlined. For a Dutch woman of 65 who did not suffer a subarachnoid hemorrhage, the unadjusted life expectancy and the discounted quality adjusted life expectancy would be 17.4 and 11.4 years, respectively.

	Strategy						
	I	II LS	III N,LS	IV N,AF,LS	V ES,N,LS	VI DS,N,LS	VII DS,N,AF,LS
patient 1	7.9	9.9	10.0	<u>11.5</u>	<u>11.2</u>	10.8	<u>11.6</u>
patient 2	6.0	7.5	7.6	<u>10.6</u>	<u>10.4</u>	9.0	<u>11.0</u>
patient 3	5.5	6.9	<u>7.2</u>	5.9	<u>7.4</u>	<u>7.5</u>	5.7
patient 4	4.0	5.0	<u>5.4</u>	4.6	<u>5.7</u>	<u>5.7</u>	4.5
patient 5	2.2	2.6	<u>2.8</u>	1.6	2.6	<u>2.8</u>	1.5

Early surgery

Early surgery (V) is never the only best strategy in this analysis. Since our estimates of the mortality and morbidity from early surgery - the most important factor - are obtained indirectly, they are quite imprecise. In order to determine when early surgery would be the best strategy, we varied the mortality from delayed surgery and early surgery by changing the surgical excess mortality and basic mortality, (see also: *Available data and estimates*) for each patient over a wide range. Figure 46 shows how for patient 1 and 3-5 changes in the basic and excess surgical risks (reflected in the mortality and morbidity from delayed surgery) affect the choice of treatment. Plausible, low values of surgical mortality and morbidity (less than 0.05 and 0.09 respectively) change the best strategy to early surgery for patient 3 and 4, more clearly so when the excess mortality is only 1.5 times that of delayed surgery. For patient 1, intermediate and high surgical risks favour postponement of surgery, and treatment with tranexamic acid, but when surgical risks are low, early surgery may be an option. For patient 2 (not in figure) early surgery is never the best choice. The high rebleeding risks favour treatment with tranexamic acid and delayed surgery. For patient 5 there is more uncertainty about the risks of early surgery and the preferred strategy. However, the dQALE of early surgery does not change much with surgical mortality and morbidity, because the chance of undergoing operation is quite small.

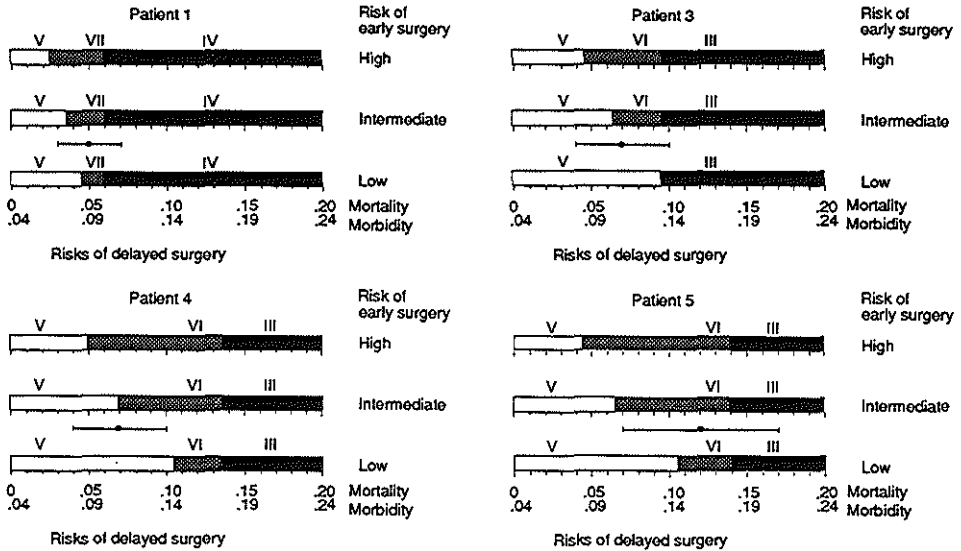

Figure 46. Threshold analysis: the effect of changes in basic and excess surgical on the mortality and morbidity from delayed surgery and early surgery, and the preferred strategy for patients 1, 3, 4 and 5. (The case for patient 2 (not displayed) is trivial, because below a surgical mortality/morbidity of 0.095/0.135 delayed surgery with TEA (VII, DS,N,AF,LS) is preferred, and above this value nimodipine and TEA (strategy IV, N,AF,LS). Early surgery is never preferred.) The shaded bar indicates which strategy has the highest expected utility, at a given level of surgical risks. When the surgical risks are low, early surgery (V, ES,N,LS) is preferred. But when the risks of early surgery are relatively high (upper bar, 3 times the risks of delayed surgery), the threshold for delayed surgery decreases, but when they are relatively low (lower bar, 1.5 times the risks of delayed surgery) the threshold for delayed surgery increases. The plausible range for the risks of delayed surgery is indicated for each patient. Very high surgical risks favour nimodipine only, strategy III (N, LS).

10.3 Discussion

This decision analysis synthesizes the available evidence on the risks and effects of surgical and medical treatment of patients with subarachnoid hemorrhage in one consistent framework and provides guide-lines for their management. Admittedly, the analysis does not permit completely certain and simple recommendations. But that has never been our aspiration, considering the complexity of the clinical problem and the still limited knowledge of sub-

arachnoid hemorrhage and the effects of treatment. As one would expect, most of our conclusions concur with current practice. However, we offer new recommendations with regard to the use of antifibrinolytics, and to the appropriateness of early surgery.

Our analysis is largely based on data from a randomized clinical trial of tranexamic acid against placebo, conducted between 1979 and 1983. Arguments for using these particular data have been given in Chapter 9. Several aspects of the management of subarachnoid hemorrhage have changed since conducting this trial, but adjustments have been made to reflect the reduced rate of infarction that resulted from the changes in fluid management and from the use of nimodipine.

The estimates of the risks of early surgery are based on extrapolation and on the literature, but not on new observations. Reliable data on the risks of surgery are scarce. We urge neurosurgical centres to publish their results, with an adequate description of the clinical characteristics of the treated patients.

Some centres that participated in the Cooperative Study had a 0% surgical mortality, suggesting that our estimates may be too high. However, the number of cases admitted to these centres was very small. When the occurrence of surgical mortality is considered as a chance-process, it is not surprising that in a small group of patients no mortality occurs. Moreover, centres were selected on the basis of good surgical results.²⁰³

Previous studies

Two other decision analytic studies of the management of subarachnoid hemorrhage exist.^{123,263} They concern special cases, and no assumptions are made about the occurrence of infarction, nor about the effects of antifibrinolytics and nimodipine. General management guide-lines cannot be distilled from them. A more detailed discussion of these studies can be found in Chapter 3.

The results of the Cooperative Study suggest a beneficial effect of early surgery compared to delayed surgery for North American centres only.¹⁵³ These centres had better surgical results than the others. On the other hand, half of the patients in the delayed surgery group did not receive antifibrinolytics. In the study of Öhman,²⁸⁹ Hunt & Hess grade I-III patients with recent subarachnoid hemorrhage were randomly allocated to surgery on day 0-3, day 4-7 or day 8 or later, there was no statistically significant difference between the treatment groups. Moreover, antifibrinolytic therapy appears not to have been administered. Therefore, these results do not disagree with ours.

Conclusions

Our analysis suggests that for patients arriving at the hospital early after the subarachnoid hemorrhage in good clinical condition, delayed surgery and antifibrinolytics is the best option. For this category of patients, (i.e. Glasgow coma score more than 11, amount of subarachnoid blood less than 9, and age less than 55) treatment with antifibrinolytics is clearly advantageous.

Early surgery for these patients seems to offer no additional benefit or no better overall outcome. But the differences in dQALE are small, thus, for centres with experience in early surgery, there is little reason to change their present practice. Moreover, if there is virtually no difference between early and delayed surgery in dQALE, the financial savings on bed usage may tip the balance. Patients in poor clinical condition, or with a heavy load of blood on the CT scan (like patients 3 and 4) should not receive antifibrinolytics. In these patients, early surgery leads to almost equal dQALE as delayed surgery without antifibrinolytics.

We hope that our recommendations will contribute to the optimum care for future patients with subarachnoid hemorrhage.

Notes

a. This chapter is adapted from: Dippel DWJ, Van Crevel H, Lindsay KW, Hijdra A, Habbema JDF. Management of subarachnoid hemorrhage: Decision analysis. Submitted for publication.

Chapter 11

General discussion

The aim of the studies in the preceding chapters is the synthesis of general clinical knowledge, empirical evidence and preferences for health outcomes in a decision analytical model of rational choice. Did we succeed? Are the results and our conclusions useful as clinical advice? Are the models and conclusions scientifically valid? The answer to the last question in particular is not straightforward. In this chapter, these matters will be discussed in general, and in relation to our studies.

Theoretically, empirical validation of decision analytical studies is possible. But what should be the design of the study? One may envisage a clinical trial with random treatment allocation that corresponds to the main branches of the decision tree, when there is still reasonable doubt about the best strategy. Another perhaps even more interesting approach would be to compare not clinical strategies, but clinical management without, and with decision analytical support. For patients with a recent transient ischaemic attack, the decision whether or not to undergo carotid angiography and perhaps endarterectomy, can be based on clinical insight and the literature, or the same decision can be based on the (yet to be updated) results of a decision analysis such as Matchar's study.²⁵⁴ With such a design it is possible to investigate whether a benefit can be attained by strictly adhering to the model's advice, and as a by-product, the model's predictions can be checked. It is of course not possible to establish the "general validity" of the decision analysis method itself.^a Care should be taken that the model's advice does not influence decisions for patients allocated to management without decision analytic support. What should be the outcome measure of the trial? Certainly it must be the same attributes, weighted with an identical utility function (perhaps with individualized parameterization) as in the original decision analysis, because otherwise, the results of the experiment and of the model cannot be compared.

Most decision analyses have been conducted because empirical studies were not feasible, thus, there are practical obstacles for such an evaluation. For example, in the unruptured aneurysm problems, empirical validation would require decades of follow-up per patient (the validity of analysis by means of patient-years of follow-up although useful by itself, in a large sample study with relatively short follow-up would meet criticism with respect to its generalisability). In subarachnoid haemorrhage, medical treatment options are theoretically easy to evaluate by randomized trial, but randomization for surgery was not considered feasible in the cooperative study of the timing of surgery in SAH,²⁰⁴ although this has been done in a smaller, but well designed study.²⁸⁹ However, the number of possible clinically relevant strategies is simply too high to be evaluated by trial.

Alternatively, one may explore the construct validity of decision analytical studies. A sound approach is for that matter to let potential decision makers, fellow decision-analysts and experts with clinical backgrounds formulate as much criticism as possible against a certain study, and consider the study valid, as long as it can stand the critique, and the critique itself is valid, i.e. aimed at the way the analysis was conducted, but not aimed at the problem itself. For example, the absence of empirical information regarding a crucial factor in a decision analysis is not a problem of the analysis, but belongs to the decision problem itself. Von Winterfeldt argues in this light that validation of the structure of a decision analysis is essentially inappropriate.³⁹³

In the next paragraphs we will summarize for each group of studies (i.e. unruptured intracranial aneurysms (Chapters 4-6), arteriovenous malformations (Chapter 7), dementia (Chapter 8) and subarachnoid haemorrhage (Chapters 9 and 10) the critique that was encountered during more than eight years of research and consultations and give our response. We will also mention useful clinical advice derived from each study's results, and give guide-lines for further research in these areas. The decision analytic literature on each subject was already discussed in Chapter 3, and the main conclusions of the studies are stated at the end of each chapter, and in the summary. These will not be repeated here. At the end of this chapter, the obstacles and opportunities for application of decision analysis will be given, in order to contribute to a discussion about the role of decision analysis in neuro-scientific research, education, training and patient-management in the clinical neurosciences.

11.1 Intracranial aneurysms and arteriovenous malformations

The decision analytic studies of the management of unruptured intracranial aneurysms in this study were preceded by an application of Van Crevel,³⁸² who described the management of a hypothetical patient, a 45-year-old woman with an unruptured 8 mm aneurysm of the left middle cerebral artery. The decision tree and utility function in this analysis form the basis for the analyses in Chapters 4-6 of this book, and for several consultations. Comments have been put forward by interested clinicians and investigators. The most important of these regarded the utility function: *"when the patient knows that he/she harbours an intracranial aneurysm, the uncertain outlook of the conservative management option will be harder to bear than when the patient does not know of his condition or when the aneurysm has been clipped effectively, and therefore, telling the patient almost implies clipping the aneurysm"*. This psychological aspect is not included in the analysis. When patients have been informed it is questionable whether they would be willing to trade off survival against reduction in fear of aneurysm rupture; anyhow, it does at least not seem rational, because rupture and its consequences for health status and longevity have already been included in the tree. Therefore, analogously to our treatment of regret and disappointment, improvement in psychological well-being is not included in the utility function, see Chapter 2, section 2.3.

Other criticisms regard specific estimates, and do not threaten the validity of the analysis. Some may argue that a decision analysis is "not possible" when empirical data are not available. But decisions will be made anyhow, as "doing nothing" is also a decision. Then why not make it explicitly, and look at it in a scientific and consistent way?

Our study concerning unruptured aneurysms in patients with TIA or familial aneurysms have demonstrated that some additional factors (such as the risk of treatment with acetyl-salicylic acid, or the risk of developing a new aneurysm) initially considered a strong factor against operation, were not that important. On the other hand, the lifetime risk of aneurysm rupture, determined by the life expectancy of the patient was a factor that tended to be underestimated in importance. Still, in specific cases a decision can be difficult, even with the guide-lines from the analyses. With the experience we have now, a treatment advice for special cases can be readily produced.^{b,c}

Several research recommendations can be made. For familial intracranial aneurysms a survey is currently conducted to investigate the occurrence of subarachnoid haemorrhage in family members of patients who presented with (aneurysmal) subarachnoid haemorrhage.⁴⁶ With regard to the risk of rupture, large follow-up studies of unoperated patients will probably not be carried out anymore. Monitoring surgical results is a necessary, but not a very attractive type of research for clinicians. However, the analyses show that surgical results in the management of unruptured intracranial aneurysms, of arteriovenous malformations, and of subarachnoid haemorrhage play a crucial role. Therefore, research in this area is strongly recommended.

No comments specific to the analysis of the management of unruptured familial arteriovenous malformations were encountered. Apart from assumptions about the occurrence and risk of pulmonary arteriovenous malformations, our decision analysis does not differ from an analysis of non-familial arteriovenous malformations. We could therefore extend our conclusions quite readily to non-familial cases.

11.2 Probabilistic diagnosis of normal pressure hydrocephalus

The decision analysis of the management of patients suspected of normal pressure hydrocephalus has been criticized because of the many assumptions that had to be made. Apart from that, there are two more fundamental difficulties. We modelled normal pressure hydrocephalus as if it was not a clinical syndrome, but a disease process, an entity that is identifiable independently of clinical signs. Thus, the gold standard for prevalence (prior probability) estimation was based on neuropathological evidence, and the gold standard for diagnostic testing was prolonged clinical observation. Both are questionable entities, but simply the best we have got. The response to shunting as a single diagnostic criterion was not sufficient in our opinion, because the possibility of a correct diagnosis in non-responding patients and the possibility of a transient response in non-NPH patients is ignored. Nevertheless, we think

we have shown that a large part of the variability in response to treatment can be explained by differences in diagnostic accuracy. Therefore, it is important that research efforts are not only directed at prognostic factors in NPH (and clinical signs should not be forgotten), but also at the rate of occurrence of prognostic and diagnostic factors (for NPH) in Alzheimer's disease. The second problematic point is the position of MID as a disease entity. The concept of MID now includes any demented patient with multiple infarcts, regardless of localization. Undoubtedly, the clinical picture differs between patients with small deep infarcts, white matter lesions or patients with large (sub)cortical infarcts. The clinical debate on this matter is just evolving, and therefore, data are lacking. It is a matter of taste whether to include such a concept without data in the analysis. We decided not to, in order to maintain a certain level of clinical acceptability of the analysis. However, interesting analytic exercises could have been carried out. Perhaps part of the problem will be resolved by studies that compare information from clinical assessment, MRI and autopsy in demented patients with vascular (and other) lesions.

11.3 Subarachnoid haemorrhage

The leading criticism of the prognostic model of subarachnoid haemorrhage is that it should have been validated on an independent sample of patients. This will be done in the near future. Especially with this study we received comments intended as severe criticism, like the following: *"Most neurosurgeons will agree that only patients with a small amount of blood on CT in good clinical condition should receive antifibrinolytic therapy"*, and *"most neurosurgeons will object to the idea that delayed surgery (with antifibrinolytic therapy) will lead to a better outcome than early surgery"*. This illustrates the sometimes difficult task of clinical decision analysts: when their recommendations are in line with current practice, the decision analysis is discarded as useless, but when the results are against intuition, the analysis is rejected also. Of course the opinion of an expert, at least partly based on intuition and implicit clinical reasoning (although valuable in itself), can never be an argument in favour or against the conclusions of an analysis. At the most, the non-coinciding of decision analytic advice with expert opinion can be reason to re-examine the model and the expert's reasoning for wrong assumptions.

With regard to the management of subarachnoid hemorrhage, a rather complex decision analysis was carried out. Nevertheless, the structure of the analysis resembled closely the way experienced clinicians think about management of this condition (i.e. in terms of prevention of complications as rebleeds and ischaemia). Important insights from this analysis were that treatment of patients with antifibrinolytics on indication (determined by the amount of subarachnoid blood on CT and the clinical condition at admission) has a place in modern SAH management. Another interesting insight can be worded as follows: it does not matter very much when the patient is operated, as long as the surgical complication rate is low, and surgery takes place even when it is in the form of elective treatment after three months.

The most important question we had asked ourselves when carrying out the analysis was whether there would be a role for antifibrinolytics in combination with delayed surgery, now that management of SAH in itself has improved. This could be affirmed. The decision analysis pointed out that a benefit is likely for certain patients with SAH. A new randomized trial of antifibrinolytic therapy is now under way.

11.4 The role of decision analysis in the clinical neurosciences

Obstacles

Several circumstances have increased the need for decision analysis in the clinical neurosciences. The development of powerful personal computers, the growing familiarity with clinical epidemiological techniques and the emergence of special centres for clinical decision sciences have facilitated the application of decision analysis to real clinical problems. However, decision-analytic applications have not found their way as easily into the clinic as once has been thought.¹⁴⁶

Perhaps the main obstacle remains the reluctance of doctors to think in terms of probability, in spite of omnipresent uncertainty.⁵² Data collected by history and physical examination or by the use of a test are treated as essentially perfect, so that uncertainties, which can be handled by probability calculus and statistical techniques, are ignored.¹⁶ It is perfectly normal and accepted for a physician in a clinical reasoning process to state (after the test has been carried out) that "test result X points at diagnosis Y, and "test result X is also compatible with not-Y". (Probably this physician will order yet another test.) Regarding prognosis doctors frequently state: "the prognosis is unknown", meaning that only probabilistic information is available. Some argue that frequentist data should not be applied to individual patients, not realizing that they thus negate the basis for their own research activities. Many tend to prefer vague terms as "unlikely" and uncommon" over precise statements as a probability of 0.05, even when the information is available in that form. The use of quantitative estimates for probabilities gives in the eyes of some an air of exactness and "overprecision" to something they consider unmeasurable. Framing effects (overestimation of rare events, anchoring, etc.) may lead intuitively to other choices than decision analysis prescribes, which makes it even harder to accept the explicit advice.¹⁶ Add to this all the fact that the principal activities in patient care are non-numerate, making the absorption of quantitative techniques even more difficult.⁴¹⁷

A way out of the problematic situation sketched above leads via education. Future doctors should learn to think in terms of likelihood and probability, and should be shown how to use probabilistic information when they think about the management of an individual patient. This requires an effort, especially from clinical teachers.⁴ In our opinion, probability theory provides the common language that would enhance clinical discussions at the bedside and during clinical rounds. Several text-books on clinical decision analysis exist,^{40,51,91,244,352} and some popular books on biostatistics and clinical epidemiology try to merge the decision analysis approach with

other quantitative methods.^{187,328,397} Some medical textbooks already contain a chapter about decision analysis in general,⁶ but decision analytic studies are not systematically referred to. (A decision-oriented textbook should have a 'signs and symptoms' or problem-oriented approach rather than a classic 'disease and disorder' approach, but this is still a rarity.)⁷ Perhaps an even greater impetus will be given when budget restrictions force the clinician to be more cost-effective in choosing between diagnostic and therapeutic possibilities on a more aggregate level.

Decision making behaviour does not only depend on how and what a doctor thinks. Several other influences play a role, such as environmental, organisational, personal, financial and economic aspects. A society that wants doctors to make rational decisions should not allow that a direct relation exists between ordering (obsolete) tests and financial reward. Stated otherwise, doctors should be paid for thinking without doing, instead of being paid for doing without thinking. The comparison of the financial structure of health systems in different European countries suggests however, that this latter is a necessary, but not a sufficient requirement for improvement.³³⁹

Opportunities

We will end with an optimistic view of the future of decision analysis. A paradigm of a decision-analytical application, not of its contents, but of the way it is organized and fits into everyday practice and education, and into a more general research effort targeted on a clinical problem in neurology, is presented.

There is no consensus about the management of patients with a certain neurological condition. A research project is instigated by a group of clinical experts and investigators. Several rounds of discussion follow, structured with the help of a preliminary decision analysis, and an extensive (computerized) search of the literature is carried out. The bulletin boards of the major centres for clinical decision sciences and the clinical literature are searched for similar decision analytic applications.

The available information from the literature and expert opinion are incorporated into a decision analysis model, together with estimates of secondary uncertainty.¹⁴² The necessary computations are carried out, and at this point it should be determined by sensitivity analysis whether it is necessary to incorporate (and elicit) patient preferences for health outcomes. The end results of the decision analysis can then be presented as a distribution over the difference in expected utility between the strategies.¹⁴² This study is called the 'state of the art' decision analysis. Important, uncertain factors are identified: the reliability of diagnostic entities, the efficacy of treatment, prognosis when untreated, the relation between clinical picture, diagnosis and prognosis, and risks of surgical or medical intervention. For certain (extreme) cases a management advice, based on the decision analysis can be given. However, a rather large 'gray area', where there is no certainty about the best management, remains. The most important,

influential factor in the analysis seems to be the efficacy of treatment and its complications. It is decided to carry out a randomized trial in order to compare the outcome in treated and untreated groups.

The randomized clinical trial is necessarily a pragmatic, intention-to-treat study. Care is taken that the "viewpoint" of the trial coincides with the viewpoint of the decision analysis. All cases with a clinical profile comparable to the key patient in the decision analysis are included. No cases with what turns out later to be aberrant diagnosis are excluded.¹⁷⁵ The preliminary decision analysis has been helpful in determining the clinical profile of cases to be included in the trial, and to identify beforehand interesting sub-groups (cases that are less prone to adverse experiences, or at high risk of the primary outcome event). Kaplan Meyer estimates of survival with and without disability are made,³⁰² and presented as partitioned survival curves.¹³⁶ Results are described in terms of (restricted) averages, not medians, because they do not combine.^{175,177} Statistical significance is assessed as a function of the weight one may give to complications relative to benefits of treatment.^{176,343} Especially when a statistically significant overall effect of treatment has been found, an analysis of (predetermined) interactions between treatment effects and patients subsets is carried out, preferably by using multivariate techniques.¹³²

The results of the trial are used to update the 'state of the art' decision analysis. The update is published as a letter to the editor in the same clinical journal as the original analysis, or as part of the discussion of the trial results. A more technical paper, describing the decision analysis techniques and the link between the decision analysis and the trial should be available also.¹⁴⁷ The recommendations of the updated 'state of the art' decision analysis may be distilled into a flow-chart or algorithm, for easy clinical use. Perhaps they will be used in a consensus paper, or in the formulation of practice guide-lines.²⁶⁸ It can also be used in education and training of residents. The state of the art analysis can also be used as a basis for decision consultation on behalf of difficult and special cases. As a welcome by-product, clinical observations and the relation between certain clinical factors and prognosis that may be discovered during the study,³⁹¹ leads to the formulation of a new project of more fundamental biomedical research.

Of the many tasks performed by physicians, the most pre-eminent is decision-making. Improving such a key task should improve the standard of patient care. We hope to have shown that work and research in the clinical neurosciences can be improved by formal decision support, in the form of decision analysis. We think improvement is necessary, because of the overwhelming growth of knowledge and the growth of diagnostic and therapeutic possibilities, and the growing demands and criticism from the general public, that is entitled to rational, balanced and well-informed clinical decisions, based on excellent clinical judgment.⁹²

Notes

- a. One example of such a study has been described by De Dombal (*Brit Med J* 1972; 2: 957-964). He compared the diagnostic performance in real-time of a computer system using independent Bayes with that of a senior clinician in patients with acute abdominal pain, in a now classic study. The comparison concerned diagnosis only, not management decisions, and turned out favourably for the computer system.
- b. See Dippel DWJ, Habbema JDF. Decision consultation for unruptured intracranial aneurysms. *Arch Neurol* 1993. Submitted for publication. Draft available from the author.
- c. Note that such an advice need not necessarily be extreme. Some analyses, especially analyses of difficult cases result in a toss-up, leading to equivocal treatment advice. This is not due to insufficient analysis, but it can be inherent to the decision situation. The eventual choice may then be based on additional (minor) considerations.
- d. On the other hand, the modern clinician should not trade the old way of reasoning for a pocket calculator, that is used to endlessly multiply likelihood-ratios without considering local normal values, priors, case-mix and clinical reality.
- e. See for example Goldman L. Quantitative aspects of clinical reasoning. In: *Harrison's Principles of internal medicine*. Braunwald E, Isselbacher KJ, Petersdorff RG, Wilson JD, Martin JB, Fauci AS (eds.). 11th ed. McGraw-Hill, New York, 1987, pp 5-11.
- f. But see for example Fenichel GM. *Clinical pediatric neurology. A signs and symptoms approach*, 2nd ed. Saunders, Philadelphia 1993.

References

- 1 Aaron JO, Hesselink JR, Oot R, Jones RL, Davis KR, Taveras JM. Complications of intravenous DSA performed for carotid artery disease: a prospective study. *Radiology* 1984; 153: 675-678.
- 2 Acosta PC, Trobe JD, Shuster JJ, Krischer JP. Diagnostic strategies in the management of unexplained visual loss. A cost-benefit analysis. *Med Decis Making* 1981; 1: 125-144.
- 3 Adams HP, Kassell NF, Torner JC, Haley EC Jr. Predicting cerebral ischemia after aneurysmal subarachnoid haemorrhage: Influences of clinical condition, CT results, and antifibrinolytic therapy. A report of the Cooperative Aneurysm Study. *Neurology* 1987; 37: 1586-1591.
- 4 Ailard JC, Hochberg FH, Franklin PD, Carter AP. Magnetic resonance imaging in a family with hereditary cerebral arteriovenous malformations. *Arch Neurol* 1989; 46: 184-187.
- 5 Allcock JM, Canham PB. Angiographic study of the growth of intracranial aneurysms. *J Neurosurg* 1976; 45: 617-621.
- 6 Allen GS, Ahn HS, Preziosi TJ, Battye R, Boone SC, Chou SN. Cerebral arterial spasm - a controlled trial of nimodipine in patients with subarachnoid hemorrhage. *N Engl J Med* 1983; 308: 619-624.
- 7 Alvord EC Jr, Loeser JD, Bailey WL, Copass MK. Subarachnoid haemorrhage due to ruptured aneurysms. A simple method of estimating prognosis. *Arch Neurol* 1972; 27: 273-284.
- 8 Aminoff MJ. Management of unruptured cerebral arteriovenous malformations. *Clin Neurosurg* 1985; 141: 177-186.
- 9 Aminoff MJ. Treatment of unruptured cerebral arteriovenous malformations. *Neurology* 1987; 37: 815-819.
- 10 Anderson M. Normal pressure hydrocephalus (editorial). *Brit Med J* 1986; 293: 837-838.
- 11 Antiplatelet trialists' collaboration. Secondary prevention of vascular disease by prolonged antiplatelet treatment. *Br Med J* 1988; 296: 320-331.
- 12 Armitage P, Berry G. *Statistical methods in medical research*. Second edition. Blackwell Scientific Publications, Oxford 1987.
- 13 Auger RG, Wiebers DO. Management of unruptured intracranial aneurysms: a decision analysis. *J Stroke Cerebrovasc Dis* 1991; 1: 174-181.
- 14 Baker RN. Prospective study of transient ischaemic attacks. In: Toole JF, Moossy J, Janeway R (eds.). *Cerebral vascular diseases*. Seventh conference. Grune & Stratton, New York 1971, pp 166-169.
- 15 Ball JB, Lukin RR, Tomsick TA, Chambers AA. Complications of intravenous digital subtraction angiography. *Arch Neurol* 1985; 42: 969-972.
- 16 Balla JA, Elstein AS, Christensen C. Obstacles to acceptance of clinical decision analysis. *Brit Med J* 1998; 298: 579-582.
- 17 Balla JI, Elstein AS. Skull x-ray assessment of head injuries: A decision-analytic approach. *Methods Inform Med* 1984; 23: 135-138.
- 18 Balla JI. Decision-making in a case of multiple sclerosis - A preliminary note. *Methods Inform Med* 1981; 20: 16-18.
- 19 Balla JI. *The diagnostic process. A model for clinical teachers*. Cambridge University Press, Cambridge, 1985.
- 20 Barclay LL, Blass JP. Evaluation and treatment of the cognitively impaired patient. In: Exton-Smith, ANJ, ed: *Practical Geriatric Medicine*. Churchill Livingstone, Edinburgh/London, 1985.
- 21 Barclay LL, Zencov A, Blass JP, Sansone J. Survival in Alzheimer's disease and vascular dementias. *Neurology* 1985; 35: 834-840.
- 22 Bardy AH. Decisions after first seizure. *A Neurol Scand* 1991; 83: 294-296.

- 23 Barnett HJR. Symptomatic carotid endarterectomy trials. *Stroke* 1990; 21(Suppl III), 2-5.
- 24 Barza M, Pauker SG. The decision to biopsy, treat, or wait in suspected herpes encephalitis. *Ann Intern Med* 1980; 92: 641-649.
- 25 Beck J R, Pauker SG. Anticoagulation and atrial fibrillation in the bradycardia-tachycardia syndrome. *Med Decis Making* 1981; 1: 285-301.
- 26 Begg CB, Berling JA. Publication bias: a problem in interpreting medical data. *J R Statist Soc (A)* 1988; 151: 419-463.
- 27 Begg CB, Berling JA. Publication bias and dissemination of clinical research. *J Natl Cancer Inst* 1989; 81: 107-115.
- 28 Bell DE, Raiffa H, Tversky A (eds.). *Decision making. Descriptive, normative, and prescriptive interactions.* Cambridge University Press. Cambridge, 1988.
- 29 Bell DE. Disappointment in decision making under uncertainty. *Operations Research* 1985; 33: 1-27.
- 30 Bell DE. Regret in decision making under uncertainty. *Operations Research* 1982; 30: 961-981.
- 31 Betti OO, Munari C, Rosier R. Stereotactic radiosurgery with the linear accelerator: treatment of arteriovenous malformations. *Neurosurgery* 1989; 24: 311-321.
- 32 Black PM. Idiopathic normal pressure hydrocephalus. *J Neurosurg* 1980; 52: 371-377.
- 33 Bolhuis PA, Defesche JC, Van der Helm HJ. Differential diagnosis of genetic disease by DNA restriction fragment length polymorphisms. *Clinica Chemica Acta* 1987; 165: 271-276.
- 34 Bonsef GJ, Essink-Bot M-L, De Charro FT, Van der Maas PJ, Habberna JDF. Orthotopic liver transplantation in The Netherlands. The results and impacts of a medical technology assessment. *Health Policy* 1990; 16: 147-161.
- 35 Borgesen SE. Conductance to outflow in normal pressure hydrocephalus. *Acta Neurochir* 1984; 17: 1-45.
- 36 Borland International Inc. Turbo Pascal version 5.5. 1989.
- 37 Bossuyt PMM, Habberna JDF. Needed: a coherent approach to uncertainty assessment in medical decision making (abstract). *Theor Surg* 1988; 3: 36.
- 38 Boston Area Anticoagulation Trial for Atrial Fibrillation Investigators. The effect of low-dose warfarin on the risk of stroke in patients with non-rheumatic atrial fibrillation. *N Engl J Med* 1990; 323: 1505-1511.
- 39 Boynton RC, Morgan BC. Cerebral arteriovenous fistulae with possible hereditary telangiectasia. *Am J Dis Child* 1973; 125: 99-101.
- 40 Bradley GW. *Disease, diagnosis and decisions.* John Wiley & Sons, Chichester, 1993.
- 41 Bradshaw JR. Computed tomography in the investigation of dementia. *Br Med J* 1983; 286: 277-280.
- 42 Brasey D-L, Fankhauser H, De Tribolet N. Hydrocéphalie à pression normale chez l'adulte. Analyse de résultats et complications après dérivation ventriculo-cardiaque. *Schweiz Med Wschr* 1988; 118: 919-923.
- 43 Braun P. The clinical management of suspected herpes virus encephalitis. A decision-analytic view. *Am J Med* 1980; 69: 895-902.
- 44 Brihaye J. Chronic subdural hematoma. *Adv Neurotraumatology* 1986; 1: 101-156.
- 45 Brisman R, Abbassioun K. Familial intracranial aneurysms. *J Neurosurg* 1971; 34: 678-682.
- 46 Bromberg JEC, Rinkel GJE, Wijdicks EFM, Ter Berg JWM, Van Gijn J. Frequentie van familiëaire aneurysmata bij patienten met een subarachnoidale bloeding. Intern rapport. Utrecht, 1992.
- 47 Brouwers PJAM, Dippel DWJ, Vermeulen M, Lindsay KW, Hasan D, Van Gijn J. The amount of blood on computed tomography as independent predictor after aneurysmal subarachnoid hemorrhage. *Stroke* 1993; 24: 809-814.
- 48 Brown RD, Wiebers DO, Forbes G, O'Fallon WM, Piepgras DG, Marsh WR, Maciunas RJ. The natural history of unruptured intracranial arteriovenous malformations. *J Neurosurg* 1988; 68: 352-357.

- 49 Canadian Cooperative Study Group, The. A randomized trial of aspirin and sulfipyrazone in threatened stroke. *N Engl J Med* 1978; 299: 53-57.
- 50 Carrera GF, Gerson DE, Schnur J, McNeil BJ. Computed tomography of the brain in patients with headache or temporal lobe epilepsy: findings and cost-effectiveness. *J Comput Assist Tomogr* 1977; 1: 200-203.
- 51 Cebul RD, Beck LH. Teaching clinical decision making. Praeger, New York, 1985.
- 52 Cebul RD. 'A look at the chief complaints' revisited. Current obstacles and opportunities for decision analysis. *Med Decis Making* 1984; 4: 271-283.
- 53 Centerwall BS, Criqui MH. Prevention of the Wernicke-Korsakoff syndrome. A cost-benefit analysis. *N Engl J Med* 1978; 299: 285-289.
- 54 Centor RM. Signal detectability: The use of ROC curves and their analyses. *Med Decis Making* 1991; 11: 102-106.
- 55 Centraal Bureau voor de Statistiek. Overlevingstafels naar leeftijd en geslacht 1986-1990. *Mndstat Bevolk* 1991; 12: 76-77.
- 56 Central Bureau of Statistics (CBS). Life tables 1981-1984. *Mndstat Bevolk* 1987; 59-60 (English Summary).
- 57 Chadwick D, Crawford P. Should unruptured arteriovenous malformations be treated. In: More dilemmas in the management of the neurological patient. Churchill Livingstone, Edinburgh 1987, Chpt 9; pp 55-63.
- 58 Chang RW, Fineberg HV. Risk-benefit considerations in the management of polymyalgia rheumatica. *Med Decis Making* 1983; 3: 459-75.
- 59 Chapman AB, Rubinstein D, Hughes R, Stears JC, Earnest MP, Johnson AM, Gabow PA, Kaehney WD. Intracranial aneurysms in autosomal dominant polycystic kidney disease. *N Engl J Med* 1992; 327: 916-920.
- 60 Christensen-Szelansky JJ. Recent developments in the psychology of judgment and decision making. Bi-monthly appearing abstracts of the literature on the theory and psychology of medical decision making. *Med Decis Making* 1980-...
- 61 Christensen E. Beneficial effect of azathioprine and prediction of prognosis in primary biliary cirrhosis. Final results of an international trial. *Gastroenterol* 1985; 89: 1084-1091.
- 62 Christensen E. Multivariate survival analysis using Cox's regression model. *Hepatology* 1987; 7: 1346-1358.
- 63 Chui HC, Victoroff JI, Margolin D, Jagust W, Shankle R, Katzman R. Criteria for the diagnosis of ischemic vascular dementia proposed by the State of California Alzheimer's Disease Diagnostic and Treatment Centers. *Neurology* 1992; 42: 473-480.
- 64 Chui HC. Dementia: a review emphasizing clinicopathologic correlation and brain-behaviour relationships. *Arch Neurol* 1989; 46: 806-814.
- 65 Chyatte D, Fode NC, Sundt TM Jr. Early versus late intracranial aneurysms surgery in subarachnoid hemorrhage. *J Neurosurg* 1988; 69: 326-331.
- 66 Clarfield AM. Normal pressure hydrocephalus: Saga or swamp? *JAMA* 1989; 262: 2592-93.
- 67 Coleman J, Menzel H, Katz E. Social processes in physicians' adoption of a new drug. *J Chron Dis* 1959; 9: 1-19.
- 68 Coser RL. Authority and decision making in a hospital: a comparative analysis. *Am Sociol Rev* 1958; 23: 56-64.
- 69 Crawford PM, West CR, Chadwick DW, Shaw MDM. Arteriovenous malformations of the brain: natural history in unoperated patients. *J Neurol Neurosurg Psychiatry* 1986; 49: 1-10.
- 70 Crockard HA, Hanlon K, Duda EE, Mullan JF. Hydrocephalus as a cause of dementia: evaluation by computerised tomography and intracranial pressure monitoring. *J Neurol Neurosurg Psychiatry* 1977; 40: 736-740.
- 71 Dalkey NC, Helmer O. An experimental application of the Delphi method to the use of experts. *Management Science* 1963; 3: 458.
- 72 Davis R, Buchanan BG, Shortliffe EH. Production rules as a representation for a knowledge-based consultation system. *Artificial Intelligence* 1977; 8: 15-45.

- 73 Dawes RM, Corrigan B., Linear models in decision making. *Psychological Bulletin* 1974; 81: 95-106.
- 74 De Dombal FT, Leaper DJ, Staniland JR, McCann AP, Horrocks JC. Computer-aided diagnosis of acute abdominal pain. *Brit Med J* 1972; 2: 9-13.
- 75 De Haan R, Aaronson N, Limburg M, Langton Hewer R, Van Crevel H. Measuring quality of life in stroke. *Stroke* 1993; 24: 320-327.
- 76 De la Monte SM, Moore GW, Monk MA, Hutchins GM. Risk factors for the development and rupture of intracranial Berry aneurysms. *Am J Med* 1985; 78: 957-964.
- 77 De Vries PH, De Vries-Robbé PF. An overview of medical expert systems. *Methods Inf Med* 1985; 24: 57-64.
- 78 Defesche JC, De Visser M, Bakker E, Bouwsma G, De Vijlder JJM, Molhuis PA. DNA restriction fragment length polymorphisms in differential diagnosis of genetic disease: application in neuromuscular diseases. *Hum Genet* 1989; 82: 55-58.
- 79 Del Ser T, Bermejo F, Arredondo JM, Bouras C, Constantinidis J. Vascular dementia. A clinicopathological study. *J Neurol Sciences* 1990; 96: 1-17.
- 80 DeMets DL. Methods for combining randomized clinical trials: Strengths and limitations. *Stat Med* 1987; 6: 341-248.
- 81 Dietch JT. Computerized tomographic scanning in cases of dementia. *West J Med* 1983; 138: 835-837
- 82 Dines DE, Arms RA, Bernatz PE, Gomes MR. Pulmonary arteriovenous fistulas. *Mayo Clin Proc* 1974; 49: 460-465.
- 83 Dion JE, Grates PC, Fox AJ, Barnett JM, Blom RJ. Clinical events following neuro-angiography: a prospective study. *Stroke* 1987; 18: 997-1004.
- 84 Dippel DWJ, Habbema JDF. Size of intracranial aneurysms and risk of rupture (letter). *J Neurosurg*. Accepted for publication.
- 85 Dippel DWJ, Ter Berg JWM, Habbema JDF, Bossuyt PMM. Decision analysis. (Letter). *Neurosurgery* 1989; 25: 668-670.
- 86 Dippel DWJ, Ter Berg JWM, Habbema JDF. Screening for unruptured familial intracranial aneurysms. A decision analysis. *Acta Neurol Scand* 1992; 86: 381-389.
- 87 Dixon W J, Brown M B, Engelman L, Hill MA, Jennrich RI (eds.). *BMDP statistical software manual*. Volume 2. Berkeley: University of California Press, 719-745, 1988.
- 88 Dolan GD, Isselhardt BJ, Cappuccio JD. The analytic hierarchy process in medical decision making: a tutorial. *Med Decis Making* 1989; 9:40-50.
- 89 Dolan JG. Can decision analysis adequately represent clinical problems? *J Clin Epidemiol* 1990; 43: 277-284.
- 90 Doubilet P, Begg CB, Weinstein MC, Braun P, Mcneil BJ. Probabilistic sensitivity analysis using Monte Carlo simulation. A practical approach. *Med Decis Making* 1985; 5: 157-177.
- 91 Dowie J, Elstein A (eds.). *Professional judgment. A reader in clinical decision making*. Cambridge University Press, Cambridge, 1988.
- 92 Dowie J, Elstein AS. *Professional judgment: a reader in clinical decision making*. Cambridge University Press, New York, 1988.
- 93 Drachman DA. New criteria for the diagnosis of vascular dementia. *Neurology* 1993; 43: 243-245.
- 94 Drake CG. Cerebral arteriovenous malformations: considerations for and experience with surgical treatment in 166 cases. *Clin Neurosurg* 1979; 26: 145-206.
- 95 Drummond MF, Stoddart GL, Torrance GW. *Methods for the economic evaluation of health care programmes*. Oxford University Press, Oxford, 1986.
- 96 Dunn DW, Epstein. *Decision making in child neurology*. Clinical decision making series. Becker, Toronto, 1987.
- 97 Earnest F, Forbes G, Sandok BA, Piepgras DG, Faust RJ, Ilstrup DM. Complications of cerebral angiography: Prospective assessment of risk. *Am J Roentgenol* 1984; 142: 247-253.

- 98 Eckman MH, Robert NJ, Parkinson DR, Latzko G, Pauker SG. Eaton-Lambert syndrome and small cell lung cancer: side effects and certainty. *Med Decis Making* 1986; 6: 174-86.
- 99 Eckman MH. A counterpoint to the analytic hierarchy process. *Med Decis Making* 1989; 9: 57-58.
- 100 Eddy DM. A manual for assessing health practices and designing practice policies: the explicit approach. The American College of Physicians, Philadelphia, 1992.
- 101 Eddy DM. Breast cancer screening
- 102 Eddy DM. Clinical decision making: From theory to practice. Cost-effectiveness analysis. A conversation with my father. *JAMA* 1991; 267: 1669-1675.
- 103 Eddy DM. Clinical decision making: From theory to practice. Rationing by patient choice. *JAMA* 1991; 265: 105-108.
- 104 Eddy DM. The confidence profile method: a Bayesian method for assessing health technologies. *Operations Research* 1989; 37: 210-228.
- 105 Edelson L, Caplan L, Rosenbaum AE. Familial aneurysm and infundibular widening. *Neuroradiology* 1972; 22: 1056-60
- 106 Eisenberg JM. Sociologic influences on decision-making by clinicians. *Ann Intern Med* 1979; 90: 957-964.
- 107 Elliot DL, Watts WJ, Reuler JB. Management of suspected temporal arteritis. A decision-analysis. *Med Decis Making* 1983; 3: 63-8.
- 108 Elstein AS, Balla JI, Iansek R. Application of decision analysis to unruptured arteriovenous malformations. *Neurosurg* 1990; 26: 545-546.
- 109 Endtz LJ. Familial incidence of intracranial aneurysms. *Acta Neurochir* 1968; 19: 297-305.
- 110 European Carotid Surgery Trialists' Collaborative Group. MRC European Carotid Surgery Trial: Interim results for symptomatic patients with severe (70-99%) or with mild (0-33%) carotid stenosis. *Lancet* 1991; 337: 1235-1243.
- 111 Feinstein AR. *Clinometrics*. Yale University Press, New Haven, 1987.
- 112 Ferguson CG, Peerless SJ, Drake CG. Natural history of intracranial aneurysms. *N Engl J Med* 1981; 305: 99.
- 113 Feussner JR, Matchar DB. When and how to study the carotid arteries. *Ann Intern Med* 1988; 109: 805-818.
- 114 Fields WS, Lemak NA, Frankowski RF, Hardy RJ. Controlled trial of aspirin in cerebral ischemia. *Stroke* 1977; 8: 301-315,
- 115 Fields WS, Lemak NA. Joint study of extracranial arterial occlusion. IX. Transient ischaemic attacks in the carotid territory. *JAMA* 1976; 235: 2608-2610.
- 116 Fields WS, Mastenikov V, Meyer JS, Meyer JS, Hass WK, Remington RD, Macdonald M. Joint study of extra-arterial occlusion. V. Progress report of prognosis following surgery or non-surgical treatment for transient cerebral ischaemic attacks and cervical carotid lesions. *JAMA* 1970; 211: 1993-2003.
- 117 Fischer P, Jellinger K, Gatterer G, Danielzeck W. Prospective neuropathological validation of Hachinski's Ischaemic Score in Dementias. *J Neurol Neurosurg Psychiatry* 1991; 54: 580-583.
- 118 Fishburn PC. Normative theories of decision making under risk and under uncertainty. In: Bell DE, Raiffa H, Tversky A (eds.). *Decision making. Descriptive, normative, and prescriptive interactions*. Cambridge University Press, Cambridge, 1988.
- 119 Fisher CM, Kistler JP, Davis JM. Relation of cerebral vasospasm to subarachnoid haemorrhage visualized by computerized tomographic scanning. *Neurosurgery* 1980; 6: 1-9.
- 120 Fisher MC. The clinical picture in occult hydrocephalus. *Clin Neurosurg* 1977; 24: 270-284.
- 121 Fisher WS. Decision analysis: a tool of the future: an application to unruptured arteriovenous malformations. *Neurosurgery* 1989; 24: 129-35.
- 122 Flamm ES. The timing of aneurysm surgery 1985. *Clin Neurosurg* 1985; 147-158.

- 123 Fleming C, Wong JB, Moskowitz AJ, Pauker SG. A peripartum neurologic event: Shooting from the hip. *Med Decis Making* 1988; 8: 55-71.
- 124 Folstein MF, Folstein SE, McHugh PR. "MINI MENTAL STATE" A practical method for grading the cognitive state of patients for the clinician. *J Psychiat Res* 1975; 12: 189-198.
- 125 Forster DMC, Steiner L, Hakanson S. Arteriovenous malformations of the brain. A long-term clinical study. *J Neurosurg* 1972; 37: 562-570.
- 126 Fox JL, Ko JP. Familial intracranial aneurysms: Six cases among 13 siblings. *J Neurosurg* 1980; 52: 501-503.
- 127 Freeman TW, Clothier L, Pazzaglia P, Lesem MD, Swann AC. A double-blind comparison of valproate and lithium in the treatment of acute mania. *Am J Psychiatry* 1992; 149: 108-111.
- 128 Friedland RP. 'Normal'-pressure hydrocephalus and the saga of the treatable dementias. *JAMA* 1989; 262: 2577-81.
- 129 Fryback DG. QALYs, HYE's, and the loss of innocence (editorial). *Med Decis Making* 1993; 13: 271-272.
- 130 Fults D, Kelly DL Jr. Natural history of arteriovenous malformations of the brain: a clinical study. *Neurosurgery* 1984; 15: 658-662.
- 131 Gado MH, Coleman RE, Lee KS, Wikhael MA, Alderson PO, Archer CR. Correlation between computerized transaxial tomography and radionuclide cisternography in dementia. *Neurology* 1976; 26: 555-560.
- 132 Gail M, Simon R. Testing for qualitative interactions between treatment effects and patient subsets. *Biometrics* 1985; 41: 361-372.
- 133 Geigy scientific tables. Vol 2. Introduction to statistics, statistical tables and mathematical formulae. 8th edition. Ciba-Geigy, Basel, 1982.
- 134 Gerner RH, Stanton A. Algorithm for patient management of acute manic states; lithium, Valproate or carbamazepine? *J Clin Psychopharmacol* 1992; 12: 57S-63S.
- 135 Glasziou P, Hilden J. Letter to the editor. *Medical Decis Making* 1986; 6: 254-456.
- 136 Glasziou P. Quality adjusted survival analysis. *Stat Med* 1990; 9: 1259-1276.
- 137 Graf CJ, Perret GE, Torner JC. Bleeding from cerebral arteriovenous malformations as part of their natural history. *J Neurosurg* 1983; 58: 331-337.
- 138 Graff-Radford NR, Goderskey JC, Jones MP. Variables predicting surgical outcome in symptomatic hydrocephalus in the elderly. *Neurology* 1989; 39: 1601-1604.
- 139 Greenberg JD, Shenkin HA, Adam R. Idiopathic normal pressure hydrocephalus. A report of 73 patients. *J Neurol* 1977; 40: 36-341.
- 140 Guidetti B, Delfata A. Intracranial arteriovenous malformations. Conservative and surgical management. *J Neurosurg* 1980; 53: 149-152.
- 141 Haan J, Thomeer RTWM. Predictive value of temporary external lumbar drainage in normal pressure hydrocephalus. *Neurosurgery* 1988; 22: 388-391.
- 142 Habbema JDF, Bossuyt PMM, Dippel DWJ, Marshall S, Hilden J. Analysing clinical decision analyses. *Stat Med* 1990; 9: 1229-1242.
- 143 Habbema JDF, Casparie AF, Mulder JH, Rutten FFH (eds.). *Medische Technology Assessment en gezondheidsbeleid*. Samson Stafleu, Alphen a/d Rijn, 1989.
- 144 Habbema JDF, Hilden J, Bjerregaard B. The measurement of performance in probabilistic diagnosis. V. General recommendations. *Meth Inform Med* 1981; 20: 97-100.
- 145 Habbema JDF, Hilden J, Bjerregaard B. The measurement of performance in probabilistic diagnosis. I. The problem, descriptive tools, and measures based on classification matrices. *Meth Inform Med* 1978; 17:217-226.

- 146 Habbema JDF, Hilden J. The measurement of performance in probabilistic diagnosis. IV. Utility considerations in therapeutics and prognostics. *Meth Inform Med* 1981; 20: 80-96.
- 147 Habbema JDF, Van Crevel H, Braakman R, Dippel DWJ. Management of intracranial aneurysms, or how to report decision analyses in clinical journals. (Letter) *Med Decis Making* 1990; 10: 223-224.
- 148 Habbema JDF, Van der Maas PJ, Dippel DWJ. A perspective on the role of decision analysis in clinical practice. *Ann Med Intern* 1986; 137: 267-273.
- 149 Hachinski V. Cerebral blood flow: Differentiation of Alzheimer's disease from multi infarct dementia. In: Katzman R and Terry RD, eds: *Alzheimer's disease: Senile dementia and related disorders*. New York: Raven Press, 1978; 97-103.
- 150 Hagard S, Carter F, Milne RG. Screening for spina bifida cystica. A cost-benefit analysis. *Brit J Prev Soc Med* 1976; 30: 40-53.
- 151 Hakim S, Adams RD. The special clinical problem of symptomatic hydrocephalus with normal cerebrospinal fluid pressure. Observations on cerebrospinal fluid hemodynamics. *J Neurol Sci* 1965; 2: 207-327.
- 152 Halal F, Mohr G, Toussi T, Martinez SN. Intracranial aneurysms: A report of a large pedigree. *Am J Med Genet* 1983; 15: 89-95.
- 153 Haley EC, Kassell NF, Torner JC. The international cooperative study on the timing of aneurysm surgery. The North American experience. *Stroke* 1992; 23: 205-214.
- 154 Hankey GJ, Warlow CP. Symptomatic carotid ischaemic events: safest and most cost-effective way of selecting patients for angiography before carotid endarterectomy. *Brit Med J* 1990; 300: 1485-1491.
- 155 Hanley JA, McNeil BJ. A method of comparing the areas under receiver operating characteristics curves derived from the same cases. *Radiology* 1983; 148: 839-843.
- 156 Harker PT, Vargas LG. The theory of ratio scale estimation: Saaty's analytic hierarchy process. *Management Sci* 1987; 33: 1383-1403.
- 157 Hamis AB. Summary of panel on choice of patients with dementia and normal pressure hydrocephalus for shunting. *Clin Neurosurg* 1977; 24: 334-336.
- 158 Hasan D, Lindsay KW, Wijdicks EFM, Murray GD, Brouwers PJAM, Bakker WH, van Gijn J, Vermeulen M. Effect of fludrocortisone acetate in patients with subarachnoid hemorrhage. *Stroke* 1989; 20: 1156-1161.
- 159 Hasan D, Vermeulen M, Wijdicks EFM, Hijdra A, Van Gijn J. Effect of fluid intake and anti-hypertensive treatment on cerebral ischemia after subarachnoid haemorrhage. *Stroke* 1989; 20: 1511-1515.
- 160 Hasan D, Vermeulen M, Wijdicks EFM, Hijdra A, Van Gijn J. Management problems in acute hydrocephalus after subarachnoid haemorrhage. *Stroke* 1989; 20: 747-753.
- 161 Hays WL. *Statistics*. 4th ed. Holt, Rinehart and Winston, New York 1988, Chapter 1: 42-47.
- 162 Health and Public Policy Committee, American College of Physicians. Diagnostic evaluation of the carotid arteries. *Ann Intern Med* 1988; 109: 835-837.
- 163 Hedges TR, Gieger GL, Albert DM. The clinical value of negative temporal artery biopsy specimens. *Arch Ophthalmol* 1983; 101: 1251-1254.
- 164 Heiskanen O. Risk of bleeding from unruptured aneurysms in cases with multiple intracranial aneurysms. *J Neurosurg* 1981; 55: 524-526.
- 165 Heiskanen O. Risks of surgery for unruptured intracranial aneurysms. *J Neurosurg* 1986; 65: 451-453.
- 166 Heros RC, Tu Y. Unruptured arteriovenous malformations: a dilemma in surgical decision making. *Clin Neurosurg* 1985; 33: 187-236.

- 167 Hertzberg TM, Tremblay GF, Lam CF. Computer-assisted localization of nervous system injuries. *Comp Biomed Res* 1987; 20: 489-496.
- 168 Heyman A. Differentiation of Alzheimer's disease from multi infarct dementia. In: Katzman R and Terry RD, eds: *Alzheimer's disease: Senile dementia and related disorders*. New York: Raven Press, 1978; 109-113.
- 169 Hijdra A, Braakman R, Van Gijn J, Vermeulen M, Van Crevel H. Aneurysmal subarachnoid haemorrhage. Complications and outcome in a hospital population. *Stroke* 1987; 18: 1061-1067.
- 170 Hijdra A, Brouwers PJAM, Van Gijn J, Vermeulen M. Grading the amount of blood on computed tomograms after subarachnoid haemorrhage. *Stroke* 1990; 21: 1156-1161.
- 171 Hijdra A, Van Gijn J, Nagelkerke NJD, Vermeulen M, Van Crevel H. Prediction of rebleeding, delayed cerebral ischemia and poor outcome after aneurysmal subarachnoid haemorrhage. *Stroke* 1988; 19: 1250-1256.
- 172 Hilden J, Bjerregaard B. Computer aided diagnosis and the atypical case. In: FT de Dombal and F Grémy, eds: *Decision Making and medical care: Can information science help?* North Holland, Amsterdam, 1976.
- 173 Hilden J, Habbema JDF, Bjerregaard B. The measurement of performance in probabilistic diagnosis. III. Methods based on continuous functions of the diagnostic probabilities. *Meth Inform Med* 1978; 17: 238-246.
- 174 Hilden J, Habbema JDF, Bjerregaard B. The measurement of performance in probabilistic diagnosis. II. Trustworthiness of the exact values of the diagnostic probabilities. *Meth Inform Med* 1978; 17: 227-237.
- 175 Hilden J, Habbema JDF. The marriage of clinical trials and decision science. *Stat Med* 1990; 9: 1243-1257.
- 176 Hilden J. Reporting clinical trials from the viewpoint of a patient's choice of treatment. *Stat Med* 1987; 6: 745-752.
- 177 Hilden J. Some problems in the assessment of survival curve utilities. Published as a discussion of the contribution by Spiegelhalter DJ, Smith AFM. *Decision analysis and clinical decisions*. In: Bithel J and Coppi R. (eds.), *Perspectives in medical statistics*. Academic Press, London, 1981.
- 178 Hilden J. The area under the ROC curve and its competitors. *Med Decis Making* 1991; 11: 95-101.
- 179 Hische EAH, Helm HJ van der, Van Walbeek HK. The cerebrospinal fluid immunoglobulin G index as a diagnostic aid in multiple sclerosis; A Bayesian approach. *Clin Chem* 1982; 28: 354-355.
- 180 Huckman MS. Normal pressure hydrocephalus: Evaluation of diagnostic and prognostic tests. *Am J Neuroradiol* 1981; 2: 385-395.
- 181 Hughes CP, Siegel BA, Coxse WS, Gado MH, Grubh RL, Coleman RE. Adult idiopathic communicating hydrocephalus with and without shunting. *J Neurol* 1978; 41: 961-971.
- 182 Hurink MGM. Applications of decision analysis in diagnostic radiology. Thesis, Rotterdam 1989, Chapter II; pp 13-47.
- 183 Hutchinson TA, Boyd NF, Feinstein AR. Scientific problems in clinical scales, as demonstrated in the Kamofsky index of performance status. *J Chron Dis* 1979; 32: 661-666.
- 184 lansek R, Balla JI. A decision-analytic approach to the role of visual evoked response and cerebrospinal fluid abnormalities in the management of singular spinal sclerosis. In: Tyrer JH, Eadie MJ (eds.). *Clinical and Experimental Neurology. Proceedings of the Australian Association of Neurologists*. Vol 21, 1985.
- 185 lansek R, Elstein AS, Balla JI. Application of decision analysis to management of cerebral arteriovenous malformation. *Lancet* 1983; 1: 1132-5.
- 186 lansek R, Elstein AS, Balla JI. Application of decision analysis to management of cerebral arteriovenous malformations. *Lancet* 1983; 1132-1135.
- 187 Ingelfinger JA, Mosteller F, Thibodeau LA, Ware JA. *Biostatistics in clinical medicine*. MacMillan, New York, 1983, Chapter 1:10-15.

- 188 Jan M, Bucheit F, Tremoulet M. Therapeutic trial of intravenous nimodipine in patients with established cerebral vasospasm after rupture of intracranial aneurysms. *Neurosurg* 1988; 23: 154-157.
- 189 Jane JA, Kassel NF, Torner JC, Winn HR. The natural history of aneurysms and arteriovenous malformations. *J Neurosurg* 1985; 62: 321-323.
- 190 Janny P, Colnet G, Veyre A, Chazal J, Barreto LC. Hydrocéphalie à pression normale. Etude pré- et postopératoire de 56 cas. *Neurochirurgie* 1981; 27: 89-96.
- 191 Jaspers R. Medical decision support. An approach in the domain of brachial plexus injuries. Thesis. Delft, 1990.
- 192 Jellinger K. Neuropathological aspects of dementias resulting from abnormal blood and cerebrospinal fluid dynamics. *Acta Neurol Belg* 1976; 76: 83-102.
- 193 Jennett B, Bond M. Assessment of outcome after severe brain damage: a practical scale. *Lancet* 1975; 480-484.
- 194 Joffe A, McCormick M, DeAngelis C. Which children with febrile seizures need a lumbar puncture? A decision analysis approach. *Am J Dis Child* 1983; 137: 153-156.
- 195 Johannesson M, Pliskin JS, Weinstein MC. Are healthy-years equivalents an improvement over Quality-adjusted Life Years? *Med Decis Making* 1993; 13: 281-286.
- 196 Jonas S, Hass WK. An approach to the maximal acceptable complication rate after surgery for transient cerebral ischaemia (TIA). *Stroke* 1979; 10: 104.
- 197 Jonas S. IMPS (Intact Months of Patient Survival): An analysis of the results of carotid endarterectomy. *Stroke* 1986; 17: 1329-1334.
- 198 Juvela S, Porras M, Heiskanen O. Natural history of unruptured intracranial aneurysms: a long-term follow-up study. *J Neurosurg* 1993; 79: 174-182.
- 199 Kahnemann D, Tversky A. Prospect theory: An analysis of decision under risk. *Econometrica* 1979; 47: 263-291.
- 200 Kalbfleisch JD, Prentice RL. The statistical analysis of failure time data New York, Wiley & Sons Inc, 1980: 70-145.
- 201 Kassel NF, Torner JC. Size of intracranial aneurysms. *Neurosurgery* 1983; 12: 291-297.
- 202 Kassel NF, Haley EC, Torner JC. Antifibrinolytic therapy in the treatment of aneurysmal subarachnoid haemorrhage. *Clin Neurosurg* 1985; 137-145.
- 203 Kassel NF, Torner JC, Haley EC, Jane JA, Adams HP, Kongable GL. The international cooperative study on the timing of aneurysm surgery: Part 1: Overall results. *J Neurosurg* 1990; 73: 18-36.
- 204 Kassel NF, Torner JC, Jane JA, Haley EC, Adams HP. The international cooperative study on the timing of aneurysm surgery. Part 2: Surgical results. *J Neurosurg* 1990; 73: 37-47.
- 205 Kassel NF, Torner JC. Size of intracranial aneurysms. *Neurosurgery* 1983; 12: 291-297
- 206 Kassirer JP, Moskowitz AJ, Lau J, Pauker SG. Decision analysis: a progress report. *Ann Intern Med* 1987; 106: 275-291.
- 207 Kassirer JP, Pauker SG. The toss-up. *N Engl J Med* 1981; 305: 1467-1469.
- 208 Katzman R. Normal pressure hydrocephalus. In: Katzman R and Terry RD, eds: *Alzheimer's disease: Senile dementia and related disorders*. Raven Press, New York, 1978, pp 115-124.
- 209 Kempster PA, Iansek R, Balla JI, Dennis PM. Value of visual evoked response and oligoclonal bands in cerebrospinal fluid in diagnosis of spinal multiple sclerosis. *Lancet* 1987; 769-771.
- 210 Kent DL, Haynor DR, Larson EB, Deyo RA. Diagnosis of lumbar spinal stenosis in adults: A meta-analysis of the accuracy of CT, MR, and myelography. *Am J Radiol* 1992; 158: 1135-1144.
- 211 King CR, Lovrien EW, Reiss J. Central nervous system arteriovenous malformations in multiple generations of a family with hereditary hemorrhagic telangiectasia. *Clin Genet* 1977; 12: 371-381.
- 212 Kirschner JP. An annotated bibliography of decision-analytic applications to health care. *Operat Res* 1980; 28: 97-113.

- 213 Knotnerus JA. The effects of disease verification and referral on the relationship between symptoms and diseases. *Med Decis Making* 1987; 7: 139-148.
- 214 Kokmen E, Okazaki H, Schoenberg BS. Epidemiological patterns and clinical features of dementia in a defined US population. *Trans Am Neurol Assoc* 1980; 105: 334-336.
- 215 Kopitnik TA, Samson DS. Management of subarachnoid haemorrhage. *J Neurol Neurosurg Psychiatry* 1993; 56: 947-959.
- 216 Koprowski CD, Longstreth WT, Cebul RD. Clinical neuroepidemiology. III. Decisions. *Arch Neurol* 1989; 46: 223-229.
- 217 Korn EL, Simon R. Measures of explained variation for survival data. *Stat Med* 1990; 9: 487-503.
- 218 Krayenbuhl HA, Yasagil MG, Flamm ES, Ten JM. Microsurgical treatment of intracranial saccular aneurysms. *J Neurosurg* 1972; 37: 678-686.
- 219 Kulikowski CA, Weiss SM. Representation of expert knowledge for consultation: The CASNET and EXPERT projects. In: Szolovits P (ed.). *Artificial intelligence in medicine*. Westview Press, Boulder, Col, 1982: 21-55.
- 220 Kurtzke JF. A review of clinical trials in the surgical treatment of cerebrovascular disease. *Neuroepidemiology* 1985; 4: 48-58.
- 221 Kwok C K, Beck JR, Pauker SG. Repeated syncope with negative diagnostic evaluation. To pace or not to pace? *Med Decis Making* 1984; 4: 351-77.
- 222 Larsson A, Wikkelso C, Billing M, Stephensen H. Clinical parameters in 74 consecutive patients shunt operated for normal pressure hydrocephalus. *Acta Neurol Scand* 1992; 84: 475-482.
- 223 Lauritzen SL, Spiegelhalter DJ. Local computations with probabilities on graphical structures and their applications to expert systems. *J R Statist Soc* 1988; 50.
- 224 Laws ER and Mokri B. Occult hydrocephalus: Results of shunting correlated with diagnostic tests. *Clin Neurosurg* 1977; 24: 316-333.
- 225 Ledley RS, Lusted LB. Reasoning foundations of medical diagnosis. *Science* 1959; 130: 9-21.
- 226 Lee ET. *Statistical methods for survival data analysis*. Chapter 10. Identification of prognostic factors related to survival time. Lifetime Learning Publications Belmont, California, 1980.
- 227 LeMay M, Hochberg FH. Ventricular differences between hydrostatic hydrocephalus and hydrocephalus ex vacuo by computed tomography. *Neuroradiology* 1979; 17: 191-195.
- 228 LeMay M. CT changes in dementing diseases. A review. *Am J Neuroradiol* 1986; 7: 841-853.
- 229 Levey AS, Pauker SG, Kassirer JP. Occult intracranial aneurysms in polycystic kidney disease. When is cerebral arteriography indicated? *N Engl J Med* 1983; 308: 986-994.
- 230 Levin LA, Jakobiec FA. Optic nerve tumors in childhood: A decision-analytical approach to their diagnosis. *Int Ophth Clin* 1992; 3: 223-240.
- 231 Liang MH, Komaroff AL. Roentgenograms in primary care patients with acute low back pain: a cost-effectiveness analysis. *Arch Intern Med* 1982; 142: 1108-1112.
- 232 Light RJ. Accumulating evidence from independent studies: What can we win and what can we lose? *Stat Med* 1987; 6: 221-228.
- 233 Lindsay KW, Teasdale GM, Knill-Jones RP. Observer variability in assessing the clinical features of subarachnoid hemorrhage. *J Neurosurg* 1983; 58: 57-62.
- 234 Linnet K. A review on the methodology for assessing diagnostic tests. *Clin Chem* 1988; 34: 1379-1386.
- 235 Linzer M, Prystowski N, Divine GW, Matchar DB, Samsa G, Harrell F, Presly JC, Pryor DB. Predicting the outcomes of electrophysiologic studies in patients with unexplained syncope. Preliminary evaluation of a derived model. *J Gen Intern Med* 1991; 6: 113-120.

- 236 Liston EH, La Rue A. Clinical differentiation of primary degenerative and multi infarct dementia. *Biol Psychiatry* 1983; 18: 1451-1484.
- 237 Llewellyn-Thomas H, Sutherland HJ, Tibshirani R, Ciampi A, Till JE, Boyd NF. The measurement of patients' values in medicine. *Med Decis Making* 1982; 2: 449-462.
- 238 Lozano AM, Leblanc R. Familial intracranial aneurysms. *J Neurosurg* 1987; 66: 522-528.
- 239 Lucas PJF, Segaar RW, Janssens AR. HEPAR: an expert system for the diagnosis of disorders of the liver and biliary tract. *Liver* 1989; 266-275.
- 240 Luce JM. Vasculitis, primary pulmonary hypertension and arteriovenous fistulas. In: JF Murray, JA Nadel (eds.). *Textbook of respiratory medicine*. Saunders, Philadelphia, 1988.
- 241 Luessenhop AJ, Gennarelli TA. Anatomical grading of supratentorial arteriovenous malformations for determining operability. *Neurosurgery* 1977; 1: 30-35.
- 242 Luessenhop AJ, Rosa L. Cerebral arteriovenous malformations. Indications for and results of surgery, and the role of intravascular techniques. *J Neurosurg* 1984; 60: 14-22.
- 243 Lunsford LD, Kondziolka D, Flickinger JC, Bissonnette DJ, Jungreis CA, Maitz AH, Horton JA, Coffey RJ. Stereotactic radiosurgery for arteriovenous malformations of the brain. *J Neurosurg* 1991; 512-524.
- 244 Lusted LB. *Introduction to medical decision making*. Thomas, Springfield, 1968.
- 245 Lyden PD, Lau GT. A critical appraisal of stroke evaluation and rating scales. *Stroke* 1991; 22: 1345-1352.
- 246 Maas A, Staipers L. Assessing utilities by means of conjoint measurement: An application in medical decision analysis. *Med Decis Making* 1992; 12: 288-297.
- 247 Magid D, Schwartz B, Craft J, Schwartz JS. Prevention of Lyme disease after tick bites. A cost-effectiveness analysis. *N Engl J Med* 1992; 327: 534-541.
- 248 Mani RL, Eisenberg RL, McDonald EJ, Pollock JA, Mani JR. Complications of catheter cerebral arteriography: analysis of 5000 procedures. I. Criteria and incidence. *Am J Roentgenol* 1978; 131: 861-865.
- 249 Mani RL, Eisenberg RL. Complications of catheter cerebral angiography: analysis of 5000 procedures. III. Assessment of arteries injected, contrast medium used, duration of procedure, and age of patient. *Am J Roentgenol* 1978; 131: 871-874.
- 250 Mani RL, Eisenberg RL. Complications of catheter cerebral arteriography: analysis of 5000 procedures. II. Relation of complication rates to clinical and arteriographic diagnoses. *Am J Roentgenol* 1978; 131: 867-869.
- 251 Manschot WA. The fundus oculi in subarachnoid haemorrhage. *Ophthalmol* 1944; 22: 281-299.
- 252 Marsh H, Maurice-Williams RS, Lindsay KW. Differences in the management of ruptured intracranial aneurysms: a survey of practice amongst British neurosurgeons. *J Neurol Neurosurg Psychiatry* 1987; 50: 965-970.
- 253 Matchar DB, Pauker SG. Carotid endarterectomy in TIA: another close call?. *Med Decis Making* 1985; 5: 362-362.
- 254 Matchar DB, Pauker SG. Endarterectomy in carotid artery disease. A decision analysis. *JAMA* 1987; 258: 793-798.
- 255 Matchar DB, Pauker SG. Transient ischaemic attacks in a man with coronary artery disease: Two strategies neck and neck. *Med Decis Making* 1986; 6: 239-249.
- 256 Maurice-Williams RS, Marsh H. Ruptured intracranial aneurysms: the overall effect of treatment and the influence of patient selection and data presentation on the reported outcome. *J Neurol Neurosurg Psychiatry* 1985; 48: 1208-1212.
- 257 McCormick WF, Acosta-Rua GJ. The size of intracranial saccular aneurysms. An autopsy study. *J Neurosurg* 1970; 33: 422-427.
- 258 McCormick WF. Problems and pathogenesis of intracranial arterial aneurysms. In: Toole JF, Moosy J, Janeway R (eds.). *Cerebral vascular disease. Seventh conference*. Grune & Stratton, New York, 1971.

- 259 McNeil BJ, Abrams HJ (eds.). *Brigham and women's handbook of diagnostic imaging*. Boston, Little, Brown and Co. 1986.
- 260 McNeil BJ, Hanley JA. Statistical approaches to the analysis of receiver operating characteristic (ROC) curves. *Med Decis Making* 1984; 4: 137-150
- 261 McNeil BJ, Thompson M, Adelstein SJ. Cost-effectiveness calculations for the diagnosis and treatment of tuberculous meningitis. *Eur J Nucl Med* 1980; 5: 271-276.
- 262 McNeil BJ, Weichselbaum R, Pauker SG. Fallacy of the five-year survival in lung cancer. *N Engl J Med* 1978; 299: 1397-1401.
- 263 McNutt RA, Pauker SG. Competing rates of risk in a patient with subarachnoid hemorrhage and myocardial infarction: It's now or never. *Med Decis Making* 1987; 7: 250-259.
- 264 Mee E, Dorrance D, Lowe D, Neil-Dwyer G. Controlled study of nimodipine in aneurysm patients treated early after subarachnoid hemorrhage. *Neurosurg* 1988; 22: 484-491.
- 265 Mehrez A, Gafni A. Healthy-years equivalents versus Quality Adjusted Life Years: In pursuit of progress. *Med Decis Making* 1993; 13: 287-292.
- 266 Mehrez A, Gafni A. Quality-adjusted life years, utility theory, and healthy years equivalents. *Med Decis Making* 1989; 9: 142-149.
- 267 Mehrez A, Gafni A. The healthy-years equivalents: How to measure them using the standard gamble approach. *Med Decis Making* 1991; 140-146.
- 268 Menken M. Practice guide-lines in neurology. *Arch Neurol* 1992; 49: 193-195.
- 269 Mertens G, Ieven M, Ursi D, Pattyn SR, Martin JJ, Parizel PM. Detection of herpes simplex virus in the cerebrospinal fluid of patients with encephalitis using the polymerase chain reaction. *J Neurol Sci* 1993; 118: 213-216.
- 270 Metz CE, Goodenough DJ, Rossman K. Evaluation of receiver operating characteristic curve data in terms of information theory, with applications in radiography. *Radiology* 1973; 109: 297-303.
- 271 Meyer JS, Kitagawa Y, Tanahashi N, Tachibana H, Kandula P, Cech DA. Evaluation of treatment of normal pressure hydrocephalus. *J Neurosurg* 1985; 62: 513-521.
- 272 Miettinen OS. Estimation of relative risk from individually matched series. *Biometrics* 1970; 26: 75-86.
- 273 Miettinen OS. The "case-control" study. Valid selection of subjects. *J Chron Dis* 1985; 38: 543-548.
- 274 Miettinen OS. Theoretical epidemiology. Chapter 9. Elements of data analysis and inference. J Wiley & Sons, New York, 1985.
- 275 Molgaard CA. Multivariate analysis of Hachinski's scale for discriminating Senile Dementia of the Alzheimer's Type from multi infarct dementia. *Neuroepidemiology* 1987; 6: 153-160.
- 276 Mölsä PK, Pajjärvi L, Rinne JO, Säkö E. Validity of clinical diagnosis in dementia: a prospective clinico-pathological study. *J Neurol Neurosurg Psychiatry* 1985; 48: 1085-1090.
- 277 Mood AM, Graybill FA, Boes DC. *Introduction to the theory of statistics*. McGraw-Hill, Singapore, 1974.
- 278 Moony C, Mushlin AI, Phelps CE. Targetting assessments of magnetic resonance imaging in suspected multiple sclerosis. *Med Decis Making* 1990; 10: 77-94.
- 279 Muizelaar JP, Vermeulen M, Van Crevel H, Hijdra A, Van Gijn J, Teasdale GM, Lindsay KW, Murray GD. Outcome of aneurysmal subarachnoid haemorrhage in patients 66 years of age and older. *Clin Neurol Neurosurg* 1988; 90: 203-207.
- 280 Mushlin AI, Detsky AS, Phelps CE, O'Connor PW, Kido DK, Kucharczyk W, Giang DW, Mooney C, Tansey CM, Hall WJ. The accuracy of magnetic resonance imaging in patients with suspected multiple sclerosis. *JAMA* 1993; 269: 3146-3151.
- 281 Nadeau SE. Temporal arteritis: a decision-analytic approach to temporal artery biopsy. *Acta Neurol Scand* 1988; 78: 90-100.

- 282 Naglie JG, Detsky AS. Treatment of chronic nonvalvular atrial fibrillation in the elderly: A decision analysis. *Med Decis Making* 1992; 12: 239-249.
- 283 Norrgård O, Ångquist K, Fodstad H, Forsell A, Lindberg M. Intracranial aneurysms and heredity. *Neurosurg* 1987; 20: 236-239.
- 284 North American Symptomatic Carotid Endarterectomy Trial Collaborators. Beneficial effect of carotid endarterectomy in symptomatic patients with high grade stenosis. *N Engl J Med* 1991; 325: 445-453.
- 285 O'Donnell TF Jr, Pauker SG, Callow AD, Kelly JJ, McBride KJ, Korwin S. The relative value of carotid non-invasive testing as determined by receiver operator characteristic curves. *Surgery* 1980; 87: 9-19.
- 286 Offringa M, Beishuizen A, Derksen-Lubsen G, Lubsen J. Seizures and fever: Can we rule out meningitis on clinical grounds alone? *Clin Pediatr* 1992; 31: 514-522.
- 287 Ogilvy CS. Radiation therapy for arteriovenous malformations. A review. *Neurosurgery* 1990; 26: 725-735.
- 288 Öhman J, Heiskanen O. Effect of nimodipine on the outcome of patients after aneurysmal subarachnoid hemorrhage and surgery. *J Neurosurg* 1988; 69: 683-686.
- 289 Öhman J, Heiskanen O. Timing of operation for ruptured supratentorial aneurysms: a prospective randomized study. *J Neurosurg* 1989; 70: 55-60.
- 290 Ojeman RG. Management of the unruptured intracranial aneurysm. *N Engl J Med* 1981; 304: 725-6
- 291 Ondra SL, Troupp H, George ED, Schwab K. The natural history of symptomatic arteriovenous malformations of the brain: a 24-year follow-up assessment. *J Neurosurg* 1990; 73: 387-391.
- 292 Orme M. Aspirin all round? *Br Med J* 1988; 296: 307-308.
- 293 Pakarinen S. Incidence, aetiology, and prognosis of primary subarachnoid hemorrhage. *Acta Neurol Scand* 1967; 43 (suppl): 9-128.
- 294 Parkinson D, Bachers G. Arteriovenous malformations. Summary of 100 consecutive cases. *J Neurosurg* 1980; 53: 285-299.
- 295 Patrick D, Appleby A. Familial intracranial aneurysms and infundibular widening. *Neuroradiology* 1983; 25: 329-34
- 296 Pauker SG, Eckman MH, Levine HJ. A decision-analytic view of anticoagulant prophylaxis for thrombo-embolism in heart disease. *Chest* 1986; 89 (Suppl): 99-106.
- 297 Pauker SG, Kassirer JP. The threshold approach to clinical decision making. *N Engl J Med* 1980; 302: 1109-1117.
- 298 Pearce JMS. Dementia, a clinical approach. Blackwell, Oxford/London, 1984.
- 299 Perricone JR, Siebert JE, Potchen EJ, Pera A, Dumoulin CL, Souza SP. Three-dimensional phase-contrast MR angiography of the head and neck: preliminary report. *Am J Roentgenol* 1990; 155: 167-176.
- 300 Pertuiset B, Ancri D, Kinuta Y, Haisa T, Bordi L, Lin C, Mahdi M, Arthuis F. Classification of supratentorial arteriovenous malformations. A score system for evaluation of operability and surgical strategy based on an analysis of 66 cases. *A Neurochir* 1991; 110: 6-16.
- 301 Petersen RC, Mokri B, Laws ER. Surgical treatment of idiopathic hydrocephalus in elderly patients. *Neurology* 1985; 307-311.
- 302 Peto R, Pike MC, Armitage P, Breslow NE, Cox DR, Howard S, Mantel N, McPherson K, Peto J, Smith PG. Design and analysis of randomized clinical trials requiring prolonged observation of each patient. Analysis and examples. *Brit J Cancer* 1977; 35: 1-39.
- 303 Peto R. Statistical aspects of cancer trials. In: *Treatment of Cancer*. KE Hainan (ed.), Chapman and Hall, London, 1982; 867-871.
- 304 Peto R. Why do we need systematic overviews of randomized trials?. *Stat Med* 1987; 6: 233-240.

- 305 Petruk KC, West M, Mohr G, Weir BKA, Benoit BG, Gentili F. Nimodipine treatment in poor grade patients. Results of a multicenter double blind placebo controlled trial. *J Neurosurgery* 1988; 68: 505-517.
- 306 Phillips LH, Whisnant JP, O'Fallon WM, Sundt TM. The unchanging pattern of subarachnoid haemorrhage in a community. *Neurology* 1980; 30: 1034-1040.
- 307 Pickard JD, Murray GD, Illingworth R, Teasdale GM, Foy PM, Humphrey PRD, Lang DA, Nelson R, Richards P, Sinar J, Bailey S, Skene A. Effect of oral nimodipine on cerebral infarction and outcome after subarachnoid haemorrhage: British aneurysm nimodipine trial. *Brit Med J* 1989; 298: 636-642.
- 308 Pickard JD. Normal pressure hydrocephalus - to shunt or not to shunt? In: Warlow C, Garfield J (eds.). *Dilemmas in the management of the neurological patient*. Churchill Livingstone, Edinburgh 1984.
- 309 Pliskin JS, Weinstein MC. Utility functions for life-years and health status. *Operations Research* 1980; 28: 206-224.
- 310 Plugge LA, Verhey FR, Jolles J. A desktop expert system for the differential diagnosis of dementia. An evaluation study. *Int J Technology Assess Health Care* 1990; 6:147-156.
- 311 Pope FM, Neil-Dwyer G. Type III collagen mutations and cerebral aneurysms. *Stroke* 1989; 20: 1432.
- 312 Pritchett ELC. Management of atrial fibrillation. *N Engl J Med* 1992; 326: 1264-1271.
- 313 Przelomski MM, Fisher M, Davidson RI, Jones HR, Marcus EM. Unruptured intracranial aneurysm and transient focal cerebral ischaemia. A follow up study. *Neurology* 1986; 36: 584-587.
- 314 Purdy PD, Samson D, Batjer HH, Risser RC. Preoperative embolization of cerebral arteriovenous malformations with polyvinyl alcohol particles: Experience in 51 adults. *A J Neuroradiol* 1990; 11: 501-510.
- 315 Raiffa H. *Decision analysis. Introductory lectures on choices under uncertainty*. Addison-Wesley, Reading (Mass), 1968.
- 316 Read JL, Quinn RJ, Berwick DM, Fineberg HV, Weinstein MC. Preferences for health outcomes. Comparison of assessment methods. *Med Decis Making* 1984; 4: 315-329.
- 317 Rinkel GJE, Wijdevicks EFM, Vermeulen M, Hageman LM, Tans JThJ, van Gijn J. Outcome in perimesencephalic (non-aneurysmal) subarachnoid hemorrhage: A follow-up study in 37 patients. *Neurology* 1990; 40: 1130-1132.
- 318 Ritchie K, Kildea O, Roline JM. The relationship between age and the prevalence of senile dementia. A meta-analysis of recent data. *Int J Epidemiol* 1992; 21: 763-769.
- 319 Roman G, Fisher M, Perl DP. Neurological manifestations of hereditary hemorrhagic telangiectasia (Rendu Osler Weber Disease): a report of two cases and review of the literature. *Ann Neurol* 1978; 4: 130-144.
- 320 Román GC, Takemichi TK, Erkinjuntti T, Cummings JL, Maseu JC, Garcia JH, Amaducci L, Orgogozo J-M, Brun A, Hofman A, Moody Dm, O'Brien MD, Yamaguchi T, Grafman J, Drayer BP, Bennett DA, Fisher M, Ogata J, Kokmne E, Bermejo F, Wolf PA, Gorelick PB, Bick KL, Pajeanu AK, Bell MA, DeCarli C, Culebras A, Korczyn AD, Bogousslavsky J, Hartmann A, Scheinberg P. Vascular Dementia: Diagnostic criteria for research studies. *Neurology* 1993; 43: 250-260.
- 321 Rose AS, Ellison GW, Meyers LW, Tourtelotte WW. Criteria for the clinical diagnosis of multiple sclerosis. *Neurology* 1976; 26: 20-22.
- 322 Rosen WG, Terry RD, Fuld PA, Katzman R, Peck A. Pathological verification of ischemic score in differentiation of dementias. *Ann Neurol* 1980; 486-488.
- 323 Rosenorn J, Eskesen V, Schmidt K. Unruptured intracranial aneurysms. an assessment of the annual risk of rupture based on epidemiological and clinical data. *Br J Neurosurg* 1988; 2: 369-77.
- 324 Ross JS, Masaryk TJ, Modic MT, Ruggieri PM, Haacke EM, Selman WR. Intracranial aneurysms: Evaluation by MR angiography. *Am J Roentgenol* 1990; 155: 159-165.
- 325 Roth AM, Milsow L, Keltner JL. The ultimate diagnosis of patients undergoing temporal artery biopsies. *Arch Ophthalmol* 1984; 102: 901-903.

- 326 Rowland LP. Surgical treatment of cervical spondylotic myelopathy: Time for a controlled trial. *Neurology* 1992; 42: 5-13.
- 327 Saaty TL. Axiomatic foundations of the analytic hierarchy process. *Management Sci* 1986; 32: 841-855.
- 328 Sackett DL, Haynes RB, Tugwell P. *Clinical epidemiology*. Little Brown and Co., Boston, 1985.
- 329 Sackett DL. Bias in analytic research. *J Chron Dis* 1979; 32: 51.
- 330 Salazar JL. Surgical treatment of asymptomatic and incidental intracranial aneurysms. *J Neurosurg* 1980; 53: 20-21.
- 331 Salmon JH. Adult hydrocephalus. Evaluation of shunt therapy in 80 patients. *J Neurosurg* 1972; 37: 423-428.
- 332 Samson DS, Hodosh RM, Clark WK. Surgical management of unruptured asymptomatic aneurysms. *J Neurosurg* 1977; 46: 731-734.
- 333 Sano K, Asano T, Tamura A. Surgical indications and decision making. In: *Acute aneurysm surgery. Pathophysiology and management*. Springer, New York, 1986; 170-180.
- 334 Saunders WH. Hereditary hemorrhagic telangiectasia. *Arch Laryngol* 1962; 76: 245-260.
- 335 Sawyer J, Ellner J, Ransohoff D F. To biopsy or not to biopsy in suspected herpes simplex encephalitis: a quantitative analysis. *Med-Decis Making* 1988; 8: 95-101.
- 336 Schachter RD. Probabilistic inference and influence diagrams. *Operations Research* 1988; 36: 589-604.
- 337 Schievink WI, Limburg M, Dreissen JJR, Peeters FLM, Ter Berg JWM. Screening for unruptured familial intracranial aneurysms: Subarachnoid hemorrhage 2 years after angiography negative for aneurysms. *Neurosurgery* 1991; 29: 434-438.
- 338 Schipper J, Kardaun JWPF, Braakman R, Van Dongen KR, Blaauw G. Lumbar disk herniation: diagnosis with CT of myelography? *Radiology* 1987; 165: 227-231.
- 339 Schrijvers G. Regionalisering en financiering van de Engelse, Zweedse en Nederlandse gezondheidszorg. *Lochem, Tijdstroom*, 1980.
- 340 Schwartz WB. Decision analysis. A look at the chief complaints. *N Engl J Med* 1979; 300: 556-559.
- 341 Segaar RW, Wilson JHP, Habbema JDF, Malchow-Møller A, Hilden J, van der Maas PJ. Transferring a diagnostic aid for jaundice. *Neth J Med* 1988; 33: 5-15.
- 342 Shapiro ED, Gerber MA, Hofabird NB, Berg AT, Feder HM, Bell GL, Rys PN, Persing DH. A controlled trial of antimicrobial prophylaxis for Lyme disease after deer-tick bites. *N Engl J Med* 1992; 327: 1769-1773.
- 343 Simes RJ. Application of statistical decision theory to treatment choices: implications for the design and analysis of clinical trials. *Stat Med* 1986; 5: 411-420.
- 344 Simon DG, Lubin MF. Cost-effectiveness of computerized tomography and magnetic resonance imaging in dementia. *Med Decis Making* 1985; 5: 335-354.
- 345 Slovic P. Choice. In: Osherson DN, Smith EE (eds.). *Thinking. An invitation to cognitive science*. Vol 3. The MIT Press, Cambridge, Massachusetts, 1990.
- 346 Sluiter-Eringa H, Orië NGM, Sluiter HJ. Pulmonary arteriovenous fistulae. Diagnosis and prognosis in noncompliant patients. *Am Rev Respir Dis* 1969; 100: 177-188.
- 347 Smith JS, Kiloh LG. The investigation of dementia: Results in 200 consecutive admissions. *Lancet* 1981: 824-827.
- 348 Smith QJ. *Decision analysis: A Bayesian approach*. London., Chapman and Hall, 1988.
- 349 Snoek JW. *Het denken van de neuroloog*. Thesis, Groningen, 1989.
- 350 Society for Medical Decision Making Committee on Standardization of Clinical Algorithms. Proposal for clinical algorithm standards. *Med Decis Making* 1992; 12: 149-154.
- 351 Sorensen PS, Pedersen H, Marquardsen J, Petersson H, Heltburg A, Simonsen A. Acetyl salicylic acid in the prevention of stroke in patients with reversible cerebral ischaemic attacks. A Danish Cooperative Study. *Stroke* 1983; 14: 15-22.

- 352 Sox HC Jr, Blatt MA, Higgins MC, Marton KI. Medical decision making. Butterworths, Stoneham, 1988.
- 353 Spanu G, Sangiovanni G, Locatelli D. Normal-pressure hydrocephalus: twelve years experience. *Neurochirurgia* 1986; 29: 15-19.
- 354 Spencer MP, Thomas GI, Moehring MA. Relation between middle cerebral artery blood flow velocity and stump pressure during carotid endarterectomy. *Stroke* 1992; 23: 1439-1445.
- 355 Spetzler RF, Martin NA. A proposed grading system for arteriovenous malformations. *J Neurosurg* 1986; 65: 476-483.
- 356 Spilker B (ed.). Quality of life assessments in clinical trials. Raven Press, New York, 1990.
- 357 Spitzer K, Thie A, Caplan LR, Kunze K. The MICROSTROKE expert system for stroke type diagnosis. *Stroke* 1989; 20: 1353-1356.
- 358 Stein BM. Surgical decisions in vascular malformations of the brain. In: Barnett HJM, Stein BM, Mohr JP, Yatsu FM (eds.). *Stroke: Pathophysiology, diagnosis and management*. Churchill Livingstone, New York, 1986: 293-336.
- 359 Suzuki J, Onuma T, Yoshimoto T. Results of early operations on cerebral aneurysms. *Surg Neurol* 1979; 11: 407-412.
- 360 Svien HJ, McRae JA. Arteriovenous anomalies of the brain. Fate in patients not having definitive surgery. *J Neurosurg* 1965; 23: -28.
- 361 Tans JTJ. Differentiation of normal pressure hydrocephalus and cerebral atrophy by computed tomography and spinal infusion test. *J Neurology* 1979; 222: 109-118.
- 362 Teasdale GM, Jennett B. Assessment of coma and impaired consciousness; a practical scale. *Lancet* 1974; 2: 81-84.
- 363 Ter Berg JWM, Bijlsma JB, Veiga Pires JA, Ludwig JW, Van der Heiden C, Tulleken CAF. Familial association of intracranial aneurysms and multiple congenital anomalies. *Arch Neurol* 1986; 33: 30-33.
- 364 Ter Berg JWM, Bijlsma JB, Willemse J. Familial occurrence of intracranial aneurysms in childhood: a case report and review of the literature. *Neuropediatrics* 1987; 18: 227-230.
- 365 Ter Berg JWM, Dippel DWJ, Habbema JDF, Bijlsma JB, Gijn J van, Tulleken CAF, Willemse J. Treatment of intact familial intracranial aneurysms: A decision-analytical approach. *Neurosurgery* 1988; 23: 329-334.
- 366 Ter Berg JWM, Dippel DWJ, Habbema JDF, Westermann CJJ, Tulleken CAF, Willemse J. Unruptured intracranial arteriovenous malformations with hereditary haemorrhagic telangiectasia. Neurosurgical treatment or not? *Acta Neurochirurgica* 1993; 121: 34-42.
- 367 Ter Berg JWM, Dippel DWJ, Limburg M, Schievink WI, Van Gijn J. Familial intracranial aneurysms. A review. *Stroke* 1992; 23: 1024-1030.
- 368 Ter Berg JWM, Overtom TMD, Ludwig JW, Bijlsma JB, Tulleken CAF, Willemse CJ. Detection of unruptured familial intracranial aneurysms by intravenous digital subtraction angiography. Screening of two affected families. *Neuroradiology* 1987; 29: 272-276.
- 369 Thomsen AM, Borgesen SE, Bruhn P, Gjerris F. Prognosis of dementia in normal pressure hydrocephalus after a shunt operation. *Ann Neurol* 1986; 20: 304-310.
- 370 Thornton JG, Liliford RJ, Johnson N. Decision analysis in medicine. *Brit Med J* 1992; 304: 1099-1103.
- 371 Tomlinson BE, Blessed G, Roth M. Observations on the brains of demented old people. *J Neurol Sciences* 1970; 11: 205-242.
- 372 Tomer JC, Kassell NF, Wallace RB, Adams HP. Preoperative prognostic factors for rebleeding and survival in aneurysm patients receiving antifibrinolytic therapy: report of the Cooperative Aneurysm Study. *Neurosurgery* 1981; 9: 506-513.
- 373 Torrance GW, Boyle MH, Horwood SP. Application of multi-attribute utility theory to measure social preferences for health states. *Operations Research* 1982; 30: 1043-1069.
- 374 Torrance GW. Utility approach to measuring health-related quality of life. *J Chron Dis* 1987; 40: 593-600.

- 375 Trumpy JH, Eldevik P. Intracranial arteriovenous malformations: conservative or surgical treatment? *Surg Neurol* 1977; 8: 171-175.
- 376 Tsevat J, Eckman MH, McNutt RA, Pauker SG. Warfarin for dilated cardiomyopathy: a bloody tough pill to swallow? *Med-Decis Making* 1989; 9: 162-169.
- 377 Tsiatis AS. A large sample study of Cox's regression model. *Ann Stat* 1981; 9: 93-108.
- 378 Tulleken CAF. A study of the anatomy of the anterior communicating artery with the aid of the operating microscope. *Clin Neurol Neurosurg* 1977; 80: 169-173
- 379 Tversky A, Kahnemann D. Judgment under uncertainty: Heuristics and biases. *Science* 1974; 185: 1124-1131.
- 380 Tversky A, Kahnemann D. Rational choice and the framing of decisions. In: Bell DE, Raiffa H, Tversky A (eds). *Decision making. Descriptive, normative, and prescriptive interactions*. Cambridge University Press. Cambridge, 1988.
- 381 Udvarhelyi GB, Wood JH, James AE, Bartelt D. Results and complications in 55 shunted patients with normal pressure hydrocephalus. *Surg Neurol* 1975; 3: 271-275.
- 382 Van Crevel H, Habbema JDF, Braakman R. Decision analysis of the management of incidental intracranial saccular aneurysms. *Neurology* 1986; 36: 1335-1339.
- 383 Van Crevel H. Dilemmas in the treatment of subarachnoid hemorrhage. *Psychiat Neurol Neurochir* 1972; 75: 417-424.
- 384 Van der Maas PJ, De Koning HJ, Van Ineveld BM, Van Oortmarssen GJ, Habbema JDF, Lubbe JThN. The cost-effectiveness of breast cancer screening. *Int J Cancer* 1989; 43: 1055-1060.
- 385 Van der Meulen JHP, Weststrate W, Van Gijn J, Habbema JDF. Is cerebral angiography indicated in infective endocarditis? *Stroke* 1992; 23: 1662-1667.
- 386 Vanderlinden RG, Chisholm LD. Vitreous haemorrhages and sudden increased intracranial pressure. *J Neurosurg* 1974; 41: 167-176.
- 387 Vanneste J, Augustijn P, Dirven C, Tan WF, Goedhart ZD. Shunting normal-pressure hydrocephalus: Do the benefits outweigh the risks? A multicenter study and literature review. *Neurology* 1992; 42: 54-59.
- 388 Vanneste J, Augustijn P, Tan WF, Dirven C. Shunting normal pressure hydrocephalus: the predictive value of combined clinical and CT data. *J Neurol Neurosurg Psychiatry* 1993; 56: 251-256.
- 389 Vermeulen M, Lindsay KW, Murray GD, Cheah F, Hijdra A, Muizelaar JP, Schannong M, Teasdale GM, Van Crevel H, Van Gijn J. Antifibrinolytic treatment in subarachnoid haemorrhage. *N Engl J Med* 1984; 311: 432-437.
- 390 Vermeulen M, Lindsay KW, Van Gijn J (eds.). *Subarachnoid hemorrhage*. Saunders, Philadelphia, 1992.
- 391 Vermeulen M. De onlogische redelijkheid van het klinisch wetenschappelijk onderzoek. Inaugurale rede. Bohn, Stafleu, Van Loghum, Houten, 1991.
- 392 Vertinsky IB, Thompson WA, Uyeno D. Measuring consumer desire for participation in clinical decision making. *Health Serv Res* 1974; 9: 121-134.
- 393 Von Winterfeldt D, Edwards W. *Decision analysis and behavioral research*. Cambridge University Press, Cambridge, 1986.
- 394 Warlow C, Garfield J. *Dilemmas in the management of the neurological patient*. Churchill-Livingstone, Edinburgh, 1984.
- 395 Warlow C, Garfield J. *More dilemmas in the management of the neurological patient*. Churchill-Livingstone, Edinburgh, 1987.
- 396 Weinstein MC, Fineberg HV, Elstein AS, Frazier HS, Neuhauser D, Neutra RR, McNeil BJ. *Clinical decision analysis*. WB Saunders Co. Philadelphia, 1980.
- 397 Weiss NS. *Clinical epidemiology. The study of the outcome of illness*. Oxford University Press, New York, 1986.
- 398 Wellman MP, Eckamn MH, Fleming C, Marshall SL, Sonnenberg FA, Pauker SG. Automated critiquing of decision trees. *Med Decis Making* 1989; 9: 272-284.

- 399 Wells CE. Chronic brain disease: An overview. *Am J Psychiatry* 1978; 135: 1-12.
- 400 Whisnant JP, Matsumoto N, Elveback LR. Transient cerebral ischaemic attacks in a community. Rochester, Minnesota, 1955 through 1969. *Mayo Clin Proc* 1973; 48: 194-198.
- 401 Whisnant JP, Phillips LH, Sundt Jr TM. Aneurysmal subarachnoid hemorrhage. Timing of surgery and mortality. *Mayo Clin Proc* 1982; 57: 471-475.
- 402 Wiebers DO, Whisnant JP, O'Fallon WM. The natural history of unruptured intracranial aneurysms. *Neurosurgery* 1983; 12: 291-297.
- 403 Wiebers DO, Whisnant JP, O'Fallon WM. The significance of unruptured intracranial aneurysms. *Neurosurgery* 1983; 12: 291-297.
- 404 Wiebers DO. Screening for unruptured intracranial aneurysms in autosomal dominant polycystic kidney disease (editorial). *N Engl J Med* 1992; 327: 953-955.
- 405 Wiesel J, Rose DN, Silver AL, Sacks HS, Bernstein RH. Lumbar puncture in asymptomatic late syphilis: An analysis of the benefits and risks. *Arch Intern Med* 1985; 145: 465-468.
- 406 Wijdicks EFM, Vermeulen M, Hijdra A, Van Gijn J. Hyponatraemia and cerebral infarction in patients with ruptured intracranial aneurysms. Is fluid restriction harmful? *Ann Neurol* 1985; 17: 137-140.
- 407 Wikkelsø, Anderson H, Blomstrand C, Lindqvist G. The clinical effect of lumbar puncture in normal pressure hydrocephalus. *J Neurol Neurosurg Psychiatry* 1982; 45: 64-69.
- 408 Williamson PM. The adoption of new drugs by doctors practising in group and solo practice. *Soc Sci Med* 1975; 9: 233-236.
- 409 Winn HR, Almaani WS, Berga SL, Jane JA, Richardson AE. The long-term outcome in patients with multiple aneurysms. Incidence of late haemorrhage and implications for treatment of incidental aneurysms. *J Neurosurg* 1985; 59: 642-651.
- 410 Winn HR, Richardson AE, Jane JA. The long-term prognosis in untreated cerebral aneurysms. I. The incidence of late hemorrhage in cerebral aneurysm: a 10 year evaluation of 364 patients. *Ann Neurol* 1977; 1: 358-70
- 411 Winn HR, Richardson AE, O'Brien W, Jane JA. The long-term prognosis in untreated cerebral aneurysm: II. Late morbidity and mortality. *Ann Neurol* 1978; 4: 418-426.
- 412 Winn HR, Taylor J, Kassell DL. Prevalence of asymptomatic incidental aneurysms. *Stroke* 1983; 14: 121.
- 413 Wirth FP, Laws ER, Piepgras D, Scott RM. Surgical treatment of incidental intracranial aneurysms. *Neurosurgery* 1983; 212: 507-511.
- 414 Wolfe CDA, Taub NA, Woodrow EJ, Burney PGJ. Assessment of scales of disability and handicap for stroke patients. *Stroke* 1991; 22: 1242-1244.
- 415 Wulff HR. How to make the best decision. Philosophical aspects of clinical decision theory. *Med Decis Making* 1981; 1: 277-283.
- 416 Yokoyama K, Asano Y, Murakawa T, Takada M, Andio T, Sakai N, Yamada H, Iwata H. Familial occurrence of arteriovenous malformation of the brain. *J Neurosurg* 1991; 74: 585-589.
- 417 Young DW. Numerical methods for decision-making in clinical care: where to now? *Journal of the Royal Society of Medicine* 1988; 81: 128-129.
- 418 Zarin DA, Pass TM. Lithium and the single episode. When to begin long-term prophylaxis for bipolar disorder. *Med Care* 1987; 25: S76-S84.
- 419 Zellem TR, Buccheit WA. Multiple intracranial arteriovenous malformations: case report. *Neurosurgery* 1985; 17: 88-93.

Summary

This thesis concerns the application of clinical decision analysis (a methodology for decision support, based on the theory of subjective expected utility, clinical epidemiology and biostatistics) to several problems in the clinical neurosciences, where diagnosis, prognosis and therapeutic choice is not obvious. The aim of our studies is the synthesis of general clinical knowledge, empirical evidence and preferences for health outcome in a normative model of rational choice.

In Chapter 2, the methodology of decision analysis is described. Uncertain events, test results and health outcomes are modelled in a decision tree with chance, decision and outcome nodes. General clinical knowledge and empirical evidence is condensed into explicit measures of uncertainty, using probability theory. Preferences for health outcome (utilities) are approximated on a quantitative scale. The expected utility for each strategy is computed by multiplying probabilities and utilities along paths in the decision tree. The effect of plausible changes in the assumptions and estimates is analysed by sensitivity analysis; i.e. by systematically varying a probability value over a plausible range, and examining the effect on the expected utility of each strategy. Related methods are described also, and the choice for decision analysis as a method for decision support in patient-oriented clinical decision making is argued, as it is the only comprehensive, complete, theoretically well founded methodology.

In Chapter 3, a search of the literature for all decision analyses published since 1975 that take on a clinical problem in the clinical neurosciences is described. These studies are reviewed and categorized with respect to methodology (risk, ROC, risk-benefit, cost-effectiveness or cost-benefit, or utility analysis). Moreover, the applicability, extendibility and up-to-date-ness of the analyses is considered.

Forty seven studies covering 28 different clinical problems in the neurosciences were identified. Twenty-seven studies lacked a case-description, and four studies did not even mention the clinical context of the problem. Almost all studies were complete, i.e. covered the problem area adequately. Seventeen studies were clearly not up to date, either because new important evidence has been published, or because new technology has become available for clinical use. However, these studies cover ten clinical problems, and four of these were followed by a new, up-to-date analysis. It is concluded that a wide spectrum of conditions in the clinical neurosciences is not yet adequately covered by decision analysis.

In Chapter 4, three patients with transient ischaemic attacks, a stenotic or ulcerating carotid lesion and an unruptured aneurysm are discussed. Decision analysis is used in comparing treatment strategies for each patient: clipping of the aneurysm, endarterectomy or both, with

or without platelet aggregation inhibitors. A full Bayesian analysis (probabilistic sensitivity analysis) with Monte Carlo simulation is used to estimate 95% confidence limits for the difference in discounted quality adjusted life expectancy between the treatment strategies.

Platelet inhibiting therapy is indicated for all three patients, despite the increased risk of complications from subarachnoid hemorrhage. Carotid endarterectomy cannot be recommended for any of the three patients. With regard to aneurysm surgery a toss-up exists in one patient, in another the aneurysm should be clipped, and in one the decision depends on the probability that the TIA's originate from the aneurysm. For patients with TIA's, a moderate carotid stenosis and an intracranial aneurysm that does not seem to be related to the symptoms, clipping of the aneurysm, nor endarterectomy can be recommended with confidence, but when the aneurysm is just as likely the source of the TIA's as not, clipping is recommended up to the age of 70, when the surgical risks are moderately high.

In Chapter 5, clinical decision analysis is applied to the treatment decisions in four patients with an unruptured familial aneurysm. The surgical treatment was uneventful in all patients except for one patient with mild mixed aphasia and facial weakness postoperatively, which deficits disappeared in less than two weeks. In the decision-analysis, discounted quality adjusted life years are used as an outcome measure. Probability estimates are extracted from the literature when available.

It is concluded that the decision to treat the aneurysm neurosurgically in three of the four patients was a correct one. In two of these three patients, the decision cannot be changed by plausible changes in estimated data. For the third patient, only the combination of a low probability of rupture, a high surgical mortality and morbidity and high discount favours conservative treatment. In the fourth patient a toss-up exists.

More knowledge of the probability of rupture, the development of other aneurysms and the results of surgery of intact intracranial aneurysms would have made an analysis more accurate. Clinical research should address these issues.

In Chapter 6 decision analysis is used to assess the decision to screen for unruptured intracranial aneurysms in two affected families, and to formulate guide-lines for similar decisions. Four strategies are compared: 'no screening', 'screening directly', 'screening twice', and 'screening later'. Intravenous and intra-arterial digital subtraction angiography techniques (iv-DSA, ia-DSA) are considered. Life years lived with and without disability are computed for each strategy. Loss of life expectancy with and without discounting and quality correction is used as an outcome measure. 'No screening' is the preferred strategy when population based estimates for the prevalence of IA's are used. Thus, the results of this analysis provide no justification for screening patients without a familial history. But a physician who thinks that the risk of an aneurysm is increased may rightly decide for screening, especially when the

patient is aged 40 to 60. Ia-DSA is preferable over iv-DSA. A scenario analysis suggests that screening with magnetic resonance angiography is only slightly better than with ia-DSA, because the complication rate of screening plays a minor role in the analysis.

In Chapter 7 clinical decision analysis is applied to treatment decisions for three patients with unruptured familial intracranial arteriovenous malformations (AVM's) in association with hereditary haemorrhagic telangiectasia. The grades of the AVM's - according to Spetzler - were 1-0-0 (two patients aged 12 and 14) and 2-0-1 (one patient aged 43). The AVM in one patient (graded 1-0-0) was operated on without sequelae. In the decision analysis, life expectancy is used as an outcome measure, with and without quality of life adjustment and discounting for time preference. It is concluded that neurosurgical treatment is the best strategy for all three patients. Because no conclusive data are available concerning the natural history and neurosurgical treatment of unruptured AVM's, we recommend the prospective application and testing of AVM grading systems. General treatment guide-lines balancing the lifetime risk of haemorrhage, risk of incomplete extirpation and surgical mortality and morbidity are presented. The analysis suggests that patients with low-graded AVM's which have not bled should be treated surgically, unless they are older than 60 years and have an increased risk of incomplete extirpation.

In Chapter 8, clinical profiles of dementia patients, differing with respect to age, duration of dementia, presence of gait abnormalities and urinary incontinence are discussed. Epidemiological data, subjective probabilities and clinical reasoning are used to predict a treatable cerebral lesion, i.e. an intracranial space occupying lesion or normal pressure hydrocephalus (NPH). Our calculations make it possible to distinguish clinically between demented patients who are - and who are not - likely to benefit from CT investigation for treatable lesions, and eventually, from cerebrospinal fluid shunting for NPH. Utility calculations show that shunting can be recommended only for a patient with the full triad of symptoms, recent onset of dementia and CT-evidence of NPH, when no other prognostic information is available. Future clinical research should address the long term prognosis of (treated) NPH patients, and the mortality of shunting, because these two factors are most critical to the shunting-decision.

In Chapter 9 we present an individualized re-analysis of a randomized placebo-controlled study of the effect of tranexamic acid on outcome after subarachnoid hemorrhage.

Individualized estimates of the risks of rebleeding, infarction, mortality from the initial hemorrhage, and of the effect of tranexamic acid were made using six prognostic factors, identified by proportional hazards regression with stepwise forward selection: age, Glasgow coma score, loss of consciousness at the ictus, retinal hemorrhage or edema, amount of subarachnoid blood on CT, and amount of intraventricular blood on CT. Adjustments were made for the effect of nimodipine and plasma volume expansion on infarction risks. For each of 64 clinical profiles the three-month mortality is computed by combining these risks.

The three-month mortality ranges from below 20% to over 80%, depending on the clinical profile. Types of patients who may and who may not benefit from tranexamic acid are identified, and the size of the effect is estimated for each clinical profile.

Treatment with tranexamic acid seems to be especially harmful for patients with a large amount of subarachnoid blood on their initial CT, and beneficial for patients with a low amount of subarachnoid blood and high risk of rebleeding. Our results can be useful in patient-oriented decision making and in designing further studies of the management of subarachnoid hemorrhage.

In Chapter 10 the management of subarachnoid hemorrhage is studied by decision analysis. Optimal treatment strategies for individual patients, combining *early surgery*, *delayed surgery*, *late elective surgery after three months*, *antifibrinolytics* and *nimodipine*, are identified.

Rebleeding, infarction and mortality risks as estimated by proportional hazards regression in a re-analysis of a randomized clinical trial of antifibrinolytics against placebo, and data from the literature are used in a decision tree to compute the chances of good recovery, moderate and severe disability and death after three months, and the (discounted quality adjusted) life expectancy for each treatment strategy.

Treatment with nimodipine, and late elective surgery for patients with good outcome who have not yet been operated, are recommended. For patients in good clinical condition, antifibrinolytics and delayed surgery form the optimum treatment strategy. However, the benefits of early or delayed surgery are small compared to late elective surgery in this group, and therefore the surgical complication rate should be low. Patients with a heavy load of subarachnoid blood on CT scan should be treated with (delayed) surgery, but not with antifibrinolytics, because of the increased risk of infarction.

In Chapter 11 the validity of the decision analytic approach is discussed. It is concluded that because empirical validation is many times not possible, the construct validity of every analysis should be explored, by exposing the study to valid criticism of potential decision makers, experts, clinical investigators and other decision analysts. For each study the critique is then summarized. It is concluded that the validity of the studies is not compromised, but the final decision is left to the reader.

At last several obstacles to the acceptance of decision analysis in the clinical neurosciences are identified. A perspective on the future role of decision analysis in the clinical neurosciences is presented.

Samenvatting

In dit proefschrift worden enkele toepassingen van beslissingsanalyse, een methode ter ondersteuning van medische besluitvorming op het gebied van de klinische neurowetenschappen (neurologie en neurochirurgie) beschreven. Klinische beslissingsanalyse is gebaseerd op utiliteitstheorie en kansrekening, waarbij gebruik wordt gemaakt van technieken en methoden uit de klinische epidemiologie en biostatistiek.

In Hoofdstuk 2 wordt de methodologie van de beslissingsanalytische ondersteuning van klinische besluitvorming beschreven. Het beslissingsprobleem wordt weergegeven door middel van een beslisboom, met daarin voor iedere mogelijke keuze de daaraan gerelateerde gebeurtenissen en uitkomsten, beschreven met behulp van met elkaar verbonden keuze-, kans- en uitkomstknopen. Klinische kennis en empirische gegevens worden samengebracht in een expliciete weergave van onzekerheden, door middel van subjectieve kanstheorie. Waarderingen van uitkomsten (utiliteiten) worden eveneens op een kwantitatieve wijze benaderd. De verwachte utiliteit van elke strategie wordt vervolgens berekend door kansen langs iedere tak van de boom en utiliteiten aan het eind van iedere tak met elkaar te vermenigvuldigen. De optie met de hoogste verwachte utiliteit wordt geadviseerd. Het effect van plausibele veranderingen in aannames wordt beoordeeld door middel van een sensitiviteits-, of gevoeligheidsanalyse: Systematisch wordt de waarde van een bepaalde variabele gewijzigd, en de resulterende veranderingen in verwachte utiliteit van de verschillende strategieën worden met elkaar vergeleken. Verschillende andere methoden voor besluitvormingsondersteuning worden kort besproken, en de keuze voor beslissingsanalyse wordt gemotiveerd als zijnde de meest eenvoudige, complete methode met een goede theoretische basis.

In Hoofdstuk 3 wordt een overzicht gegeven van sinds 1975 gepubliceerde beslissingsanalyses op het terrein van de neurowetenschappen. De studies worden kort besproken en gecategoriseerd naar de gehanteerde methode (risico-analyse, ROC analyse, cost-benefit of cost-effectiveness analyse, of utiliteitsanalyse. De toepasbaarheid van de studies in de praktijk wordt onderzocht door systematisch enkele kenmerken na te gaan. Deze kenmerken zijn: de aanwezigheid van een casus- en contextbeschrijving, compleetheid, uitbreidbaarheid, en up-to-date zijn.

Zevenenveertig studies betreffende 28 verschillende neurologische onderwerpen werden gevonden. Zevenentwintig studies ontbeerden een casus-beschrijving, en bij vier werd niet eens de context omschreven. Zeventien waren achterhaald, soms omdat belangrijke nieuwe empirische gegevens, en ongeveer even vaak omdat nieuwe diagnostische of therapeutische mogelijkheden beschikbaar waren gekomen. Deze studies betreffen echter maar tien verschillende toepassingen, waarvan vier reeds door een nieuwe analyse waren behandeld.

In Hoofdstuk 4 worden drie patiënten met "transient ischemic attacks", een carotisstenose en een ongeruptureerd aneurysma beschreven. Door middel van een beslissingsanalyse worden de behandelingsmogelijkheden vergeleken (aneurysma chirurgie, endarteriëctomie, beide of geen van beide, en al of niet plaatjes-aggregatieremmers). Een volledige Bayesiaanse analyse met een Monte Carlo simulatie wordt gebruikt om 95% betrouwbaarheidsintervallen te berekenen voor het verschil in verwachte utiliteit tussen de behandelingsopties.

Plaatjes-aggregatieremmers blijken geïndiceerd te zijn voor alle drie de patiënten, ondanks het verhoogde risico op complicaties van de eventuele subarachnoidale bloeding. Carotis endarteriëctomie kan voor geen van de drie patiënten worden aanbevolen. Wat betreft aneurysma chirurgie bestaat een "toss-up" voor één patiënt, voor de tweede kan operatie worden geadviseerd, en voor een derde hangt de keuze tussen wel of niet opereren vooral af van de kans dat het de TIA's ontstaan door thrombo-embolieën vanuit het aneurysma. Voor patiënten met TIA's, een carotisstenose en een ongeruptureerd aneurysma kan endarteriëctomie noch aneurysma chirurgie zonder meer met zekerheid worden aanbevolen. Maar als de patiënt jonger is dan 70, en het aneurysma is met even grote mate van waarschijnlijkheid de bron van de TIA's als het aneurysma, dan kan aneurysma chirurgie wel worden geadviseerd, ook al zijn de operatierisico's matig hoog.

In Hoofdstuk 5 wordt beslissingsanalyse toegepast op de beslissing om vier patiënten met een ongeruptureerd aneurysma te opereren. De operatie verliep bij deze patiënten ongecompliceerd, behalve bij een patiënt, bij wie post-operatief een geringe gemengde afasie en een lichte zwakte van de linker gelaatshelft werd opgemerkt, welke beide na twee weken waren verdwenen.

Op grond van de analyse wordt geconcludeerd dat de beslissing om de patiënten te opereren correct was bij drie van de vier patiënten. In twee van de drie gevallen was deze conclusie niet gevoelig voor aannemelijke veranderingen in de kansschattingen. Voor de derde patiënt veranderde de conclusie alleen bij (onwaarschijnlijke) combinaties van een lage ruptuurkans, een hoog operatierisico, en een hoge jaarlijkse "discount". Voor de vierde patiënt bestond een "toss-up". Meer kennis over het ruptuurrisico, het ontstaan van nieuwe aneurysmata bij deze patiënten, en over de operatierisico's zou de analyse preciezer hebben kunnen doen zijn.

In Hoofdstuk 6 wordt beslissingsanalyse gebruikt om het besluit twee families te screenen op de aanwezigheid van ongeruptureerde familiale aneurysmata te evalueren. Tevens worden richtlijnen gegeven voor gelijksoortige, nieuwe beslissingen. Vier strategieën worden met elkaar vergeleken: 'niet screenen', inmiddellijk screenen, screenen na vijf jaar, en beide. Intraveneuze en intra-arteriële digitale substractieangiografie (iv-DSA, respectievelijk iaDSA) worden beschouwd. De levensverwachting met en zonder ernstige handicap wordt berekend en de levensverwachting met en zonder kwaliteitscorrectie en "discount" wordt gebruikt als vergelijkingsmaat. 'Niet screenen' is de aanbevolen strategie als populatie schattingen van de

prevalentie van intracranieële aneurysmata worden gebruikt. De resultaten van de analyse rechtvaardigen dus niet het screenen van willekeurige patiënten zonder familiale belasting. Maar een arts die denkt dat het risico op de aanwezigheid van een ongeruptureerd aneurysma is verhoogd, kan goed onderbouwd kiezen voor screenen, vooral wanneer de patiënt een leeftijd heeft tussen 40 en 60. Ia DSA wordt geprefereerd boven iv-DSA. Een scenario analyse suggereert dat screenen met magnetische resonantie angiografie slechts geringe winst oplevert, vooral omdat de complicaties van screenen slechts een ondergeschikte rol spelen in de analyse.

In Hoofdstuk 7 wordt beslissingsanalyse toegepast op de behandelingskeuze bij drie patiënten met een niet-gebloed-hebbende arterioveneuze malformatie in combinatie met hereditaire haemorrhagische telangiectasieën. De gradering van de AVM's - volgens Spetzler - bedroeg 1-0-0 (twee patiënten van 12 en 14 jaar), en 2-0-1 (een patiënt van 43 jaar). Bij een van de drie patiënten werd de arterioveneuze malformatie geopereerd zonder complicaties. In de beslissingsanalyse wordt weer levensverwachting met en zonder kwaliteitscorrectie en discount gebruikt om de strategieën te vergelijken. Opereren lijkt de beste strategie te zijn voor alle drie de patiënten. Omdat echter de literatuurgegevens betreffende operatieresultaten en natuurlijk beloop beperkt zijn, is het van belang dat in toekomstige studies graderingsystemen voor AVM's prospectief worden toegepast. Algemene richtlijnen voor de behandelingskeuze worden gegeven, waarbij het cumulatieve risico op bloeding, de kans op onvolledige extirpatie, en de complicaties van de operatie tegen elkaar worden afgewogen. De analyse maakt aannemelijk dat patiënten met laag-gradige AVM's die nog niet hebben gebloed dienen te worden geopereerd, behalve als zij ouder zijn dan 60 én een verhoogd risico op incomplete extirpatie lopen.

In Hoofdstuk 8 worden klinische profielen van dementie patiënten, verschillend wat betreft leeftijd, aanwezigheid van loopstoornissen en urine-incontinentie besproken. Epidemiologische gegevens, subjectieve kansschattingen en één klinisch redeneertrand worden tesamen gebruikt om een behandelbare cerebrale laesie te voorspellen, n.l. een ruimte-innemend proces of normal pressure hydrocephalus (NPH). Onze berekeningen maken het mogelijk om op klinische gronden een onderscheid te maken tussen dementie patiënten die wel en niet waarschijnlijk voordeel behalen aan het ondergaan van een CT schedel in verband met de cerebrale laesies en de mogelijkheid van het ondergaan van een liquor-shunt. Utiliteitsberekeningen laten zien dat shunting alleen kan worden aanbevolen voor een patiënt met de volledige trias van symptomen, én aanwijzingen op CT voor NPH, wanneer verder geen prognostische informatie beschikbaar is. Toekomstig klinisch onderzoek zou zich (ook) moeten richten op de operatiecomplicaties en op de lange termijn prognose bij deze patiënten, omdat deze twee factoren in de beslissingsanalyse van het meeste belang bleken.

In Hoofdstuk 9 wordt een heranalyse van een gerandomiseerde placebo gecontroleerde studie van het effect van tranexaminezuur op de gevolgen van een subarachnoidale bloeding beschreven. Geïndividualiseerde schattingen van de risico's van recidief bloedingen, ischemie en de sterfte aan de bloeding zelf werden gebaseerd op 6 prognostische factoren, die werden gekozen met behulp van proportional hazards regressie met stapsgewijs voorwaartse selectie: leeftijd, Glasgow coma score, bewustzijnsverlies ten tijde van de eerste bloeding, preretinale bloedingen of papiloedeem, hoeveelheid subarachnoidaal bloed op de CT, en hoeveelheid intraventriculair bloed op de CT. De schattingen werden aangepast voor het effect van nimodipine en plasma volume expansie op het risico van ischemie. Voor elk van de 64 patiënten-profielen werd de drie-maands sterfte berekend door de drie risico's te combineren.

De drie-maands sterfte varieert van 20% tot 80%, afhankelijk van het patiënten-profiel. Types patiënten die mogelijk wel en niet baat hebben bij behandeling met tranexaminezuur werden geïdentificeerd, en de grootte van het effect werd geschat voor ieder patiënten-profiel. Behandeling met tranexaminezuur lijkt vooral schadelijk te zijn voor patiënten met een grote hoeveelheid subarachnoidaal bloed op de CT bij binnenkomst, en een gunstig effect te hebben voor patiënten met een kleine hoeveelheid bloed en een hoog recidief-risico. Deze resultaten kunnen van belang zijn bij geïndividualiseerde besluitvorming, en bij het ontwerpen en plannen van verdere studies op het gebied van de behandeling van subarachnoidale bloedingen.

In Hoofdstuk 10 wordt het beleid bij patiënten met een subarachnoidale bloeding bestudeerd met behulp van een beslissingsanalyse. Optimale behandelingsstrategieën voor individuele patiënten, bestaande uit combinaties van vroeg (op dag 2) vertraagd (op dag 10) opereren en laat-electief (na drie maanden) opereren, tranexaminezuur en nimodipine worden geïdentificeerd.

De risico's van recidief bloeding, ischemie en sterfte aan de bloeding zelf, zoals geschat met behulp van proportional hazards regression in een heranalyse van een gerandomiseerde studie van antifibrinolytica en placebo, en gegevens uit de literatuur worden gebruikt in een beslisboom om de kansen op goed herstel, matige en ernstige invaliditeit en sterfte na drie maanden, en de "discounted quality adjusted life expectancy" voor iedere behandelingsstrategie te berekenen.

Behandeling met nimodipine, en late electieve operatie voor patiënten met een goed herstel die nog niet zijn geopereerd kan zonder meer worden aanbevolen. Voor patiënten die in een goede toestand het ziekenhuis binnenkomen, vormen antifibrinolytica met vertraagde operatie de optimale behandelingsstrategie. De winst van vroeg of vertraagd opereren is klein in deze groep wanneer wordt vergeleken met laat-electief ingrijpen, en daarom dient de kans op

operatie complicaties laag te zijn. Patiënten met een grote hoeveelheid bloed op de CT zouden moeten worden behandeld met (vertraagde) operatie, maar niet met antifibrinolytica, vanwege het verhoogde risico op cerebrale ischemie.

In Hoofdstuk 11 wordt de validiteit van de beslissingsanalytische benadering van klinische besluitvorming besproken. De conclusie luidt dat empirische validering vaak niet mogelijk zal zijn, en dat daarom de construct-validiteit dient te worden geëxploreerd, door de studie bloot te stellen aan valide kritiek van beslissers, experts, klinische onderzoekers en andere beslissingsanalytici. De mogelijke kritiek op iedere studie wordt dan samengevat en bediscussieerd. Een voorlopige conclusie is dat de validiteit van de studies niet in het gedrang is gekomen, maar de uiteindelijke beslissing wordt overgelaten aan de lezer.

Tot slot worden belemmeringen en mogelijkheden voor de verdere ontwikkeling van beslissingsanalyse in de klinische neurowetenschappen geschetst.

Acknowledgements

Dik Habbema, promotor and supervisor of the studies presented here, is a good and critical teacher, an excellent investigator and a very amiable person too. He gave me ample opportunity to get involved with an exciting form of applied medical research. Hans van Crevel kept me in touch with clinical reality, especially in the early and late phases of this project. On many pages the results of his advice can be found. Many pleasant and fruitful Sunday afternoons have been spent with Hans ter Berg, who is co-author of three chapters of this book. Rien Vermeulen showed me how to use scientific information in the clinic, and clinical experience while doing research. The other co-authors, of whom Ken Lindsay, Albert Hijdra and Professors Jan van Gijn and Reinder Braakman deserve special mention, made critical, but pleasant and encouraging writing partners.

Koos Lubsen concerned himself for the short period in which he was head of the Centre for Clinical Decision Sciences with my background in clinical epidemiology, and urged me to attend Olli Miettinen's course on "Principles of intervention research". Dr Steve Pauker showed me how to debug a decision tree and keep up good spirits, even when time is really running out. He let me visit his department, to get an impression of the organisation of a busy decision consultation service. Dr Jørgen Hilden gave helpful comments on a preliminary version of the manuscript of Chapter 8. His many publications on the theory quantitative techniques for medical decision support have been quite important to me while writing this book. During his (too short) stay at the Centre for Clinical Decision Sciences, Patrick Bossuyt was always available for methodological advice. Ernst Delwel helped with the final touches to Chapter 8.

Paul van der Linden invested some of his precious time to digest the raw manuscript, and gave very useful advice, from the viewpoint of the interested health-care manager. Jan Kardaun and Rob Segaar, friends and former room-mates at the Department of Public Health, were good for many evenings of lively discussion on quantitative methods in clinical decision making and related subjects. The workers at the Centre for Clinical Decision Sciences and the Department of Public Health of the Erasmus University have been nice and supportive colleagues. The residents and staff of the Department of Neurology have been able to create an atmosphere that allows a natural blending of clinical research and patient care.

My parents gave me the opportunity to study and helped me to go on during the first years of my study, when the study of medicine appeared boring rather than challenging. It was actually my girl-friend Ingrid's idea to start working as an investigator in clinical decision sciences. She has always supported me and let me work late hours - within reasonable limits. Simon's sleeping habits were a necessary condition for finishing this work. Leon, and the neighbours- Ann, Rob and Kim & Jet (who designed the front cover) have taken more than their share of what I did not do without complaining. My friends and family, whom I have

sometimes scandalously neglected during the past years have always tried to show some understanding, and knew how to find the right pitch of voice when asking "when it would be finished". Well, it is now, thanks to everyone mentioned here.

Curriculum vitae

De auteur van dit proefschrift zag op 2 juli 1959 the Utrecht het levenslicht. De middelbare schoolopleiding volgde hij in Nijmegen aan de Nijmeegse Scholengemeenschap. Het in 1977 behaalde diploma Gymnasium B werd gebruikt voor de toelating tot de studie Geneeskunde te Utrecht. In 1981 behaalde hij het kandidaatsexamen. In deze periode werd niet onvriendelijk gemusiceerd, "gekraakt" en werd een functie vervuld als vrijwillig medewerker, later bestuurslid van het Klachtenburo Justitie-optreden te Utrecht. In 1984 legde hij het doctoraalexamen met een extra bijvak Ziekenhuiswetenschappen af, en in 1985 volgde het artsexamen. Van 1985 tot en met 1989 was de schrijver verbonden als wetenschappelijk onderzoeker aan het Instituut Maatschappelijke Gezondheidszorg der Erasmus Universiteit (Hoofd: Professor dr PJ van der Maas), waarbij hij de laatste drie jaren was gedetacheerd bij het Centrum voor Klinische Besliskunde (Hoofd: Professor dr J Lubsen, sinds 1991: Professor dr JDF Habbema) en werd opgeleid tot klinisch besliskundige. Hier heeft hij nog een honoraire aanstelling. In de eerste helft van 1990 volgde een rentrée in de kliniek, waarbij hij werd begeleid door Professor dr JHP Wilson en zijn staf, (afdeling Interne Geneeskunde II, Ziekenhuis Dijkzigt). Medio 1990 werd de opleiding tot neuroloog aangevangen (Afdeling Neurologie, Ziekenhuis Dijkzigt, hoofd en opleider: Professor dr FGA van der Meché, gedurende het eerste jaar Professor dr A Staal). Schrijver dezes woont samen en heeft een voorspoedig opgroeiende zoon.

List of publications

- 1 Habbema JDF, Van der Maas PJ, Dippel DWJ. A perspective on the role of decision analysis in clinical practice. *Ann Med Intern* 1986; 137: 267-273.
- 2 Habbema JDF, Dippel DWJ. Survivors-only bias in estimating survival in Alzheimer's disease and vascular dementia (letter). *Neurology* 1986; 36: 1009.
- 3 Dippel DWJ, Habbema JDF. Decision analysis: unruptured intracranial aneurysms (abstract). *Theor Surg* 1988; 3: 38.
- 4 Ter Berg JWM, Dippel DWJ, Habbema JDF, Bijlsma JB, Van Gijn J, Tulleken CAF, Willemse J. Treatment of intact familial intracranial aneurysms: A decision analytical approach. *Neurosurgery* 1988; 23: 329-334.
- 5 Touw-Otten F, De Melker RA, Dagnelie DF, Dippel DWJ. Antibioticabeleid bij tonsillitis acuta door de huisarts; een beslis-kundige analyse. *Ned Tijdschr Geneesk* 1988; 132: 1743-1748.
- 6 Dippel DWJ, Ter Berg JWM, Habbema JDF, Bossuyt PMM. Decision analysis (letter). *Neurosurgery* 1989; 25: 668-670.
- 7 Habbema JDF, Van Crevel H, Braakman R, Dippel DWJ. Management of intracranial aneurysms, or how to report decision analyses in clinical journals (letter). *Med Decis Making* 1990; 10: 223-224.
- 8 Habbema JDF, Bossuyt PMM, Dippel DWJ, Marshall S, Hilden J. Analysing clinical decision analyses. *Stat Med* 1990; 9: 1229-1242.
- 9 Dippel DWJ, Van Crevel H, Lindsay KW, Habbema JDF. Management of subarachnoid hemorrhage (Abstract). *Theor Surg* 1990; 5: 149.
- 10 Van Dijk PTM, Dippel DWJ, Habbema JDF. Survival of patients with dementia. *J Am Geriatr Soc* 1991; 39: 603-610.
- 11 Dippel DWJ, Ter Berg JWM, Habbema JDF. Screening for unruptured familial intracranial aneurysms. A decision analysis. *Acta Neurol Scand* 1992; 86: 381-389.
- 12 Ter Berg JWM, Dippel DWJ, Limburg M, Schievink WI, Van Gijn J. Familial intracranial aneurysms. A review. *Stroke* 1992; 23: 1024-1030.
- 13 Dippel DWJ, Touw-Otten F, Habbema JDF. Management of children with streptococcal pharyngitis. A decision analysis. *J Fam Pract* 1992; 34: 149-159.
- 14 Dippel DWJ, Touw-Otten F, Habbema JDF. Streptococcal pharyngitis (letter). *J Fam Pract* 1992; 35: 136-138.
- 15 Habbema JDF, Dippel DWJ, Hijdra A, Lindsay KW, Van Crevel H. Decision making in subarachnoid hemorrhage. Individualized re-analysis of a trial, and a decision analysis of different patient profiles (Abstract). *Theor Surg* 1992; 7: 148.
- 16 Van Dijk PTM, Van de Sande HJ, Dippel DWJ, Habbema JDF. The nature of excess mortality in nursing home patients with dementia. *J Gerontol* 1992; 47: M28-M34.
- 17 Ter Berg JWM, Dippel DWJ, Habbema JDF, Westermann CJJ, Tulleken CAF, Willemse J. Unruptured arteriovenous malformations with hereditary haemorrhagic telangiectasia. Neurosurgical treatment or not? *Acta Neurochirurgica* 1993; 121: 34-42.
- 18 Brouwers PJAM, Dippel DWJ, Vermeulen M, Lindsay KW, Hasan D, Van Gijn J. The amount of blood on computed tomography as independent predictor after aneurysmal subarachnoid hemorrhage. *Stroke* 1993; 24: 809-814.
- 19 Van Gelder T, Geurs Ph, Kho GS, Dippel DWJ, Vecht ChJ, Splinter TAW. Cortical blindness and seizures following cisplatin treatment: Both of epileptic origin? *Eur J Cancer* 1993; 29A: 1497-1498.
- 20 Dippel DWJ, Habbema JDF. Probabilistic diagnosis of normal pressure hydrocephalus and other treatable cerebral lesions in dementia. *J Neurol Sci*. In press.

List of publications

- 21 Dippel DWJ, Vermeulen M, Braakman R, Habbema JDF. Transient ischemic attacks, carotid stenosis and an intracranial aneurysm. A decision analysis. *Neurosurgery*. Accepted for publication.
- 22 Dippel DWJ, Habbema JDF. Size of intracranial aneurysms (letter) *J Neurosurgery*. Accepted for publication.

Index

- algorithms, 45
- analytic hierarchy process, 45
- aneurysm, mycotic, 54
- angiography, 53, 79, 91, 101, 151
- angiopgraphy, 64
- arteriovenous malformation, 100
- arteriovenous malformations, 50
- atrial fibrillation, 51
- attributes
 - of health outcomes, 28

- Bayes' theorem, 24
- Bayes' theorem, 121
- Bayesian analysis, 75

- calibration, 22
- carotid stenosis, 51
- chance node, 16
- conditional independence, 27
- confidence interval
 - confidence limits
- confidence limits, 20, 39, 41, 75, 76
- confidence profiles, 21, 44
- conjoint measurement, 31
- connectivity, 30
- cost-effectiveness, 42, 48, 62
- cost-effectiveness analysis, 43
- cut-off level, 42
- cut-off point, 27
- cut-off value, 27, 42

- decision node, 16
- decision rule, 27
- decision tree, 15
- dementia, 57, 112
- direct scaling, 31
- disappointment, 34
- discount, 32, 33, 35, 53, 66, 82, 92, 104, 154
- dominance, 29

- Eaton-Lambert syndrome, 56
- elicitation
 - of utilities, 31
- endarterectomy, 64
- epilepsy, 56
- expected utility, 16
- expert systems, 46
- extendibility, 49
- extremeness, 21

- flow diagrams, 45
- framing, 44

- global association factor, 27, 114, 125
- gold standard, 27, 55, 119, 164

- head-injury, 56
- hemianopsia, 56, 101
- herniated disk, 57
- herpes simplex encephalitis, 52

- influence analysis
 - sensitivity analysis
 - two-way, 37
- influence diagrams, 42, 44
- intracranial aneurysm, 53, 64, 79, 87, 104, 128, 145
- invariance, 45

- key patient, 20

- levels
 - of health outcome-attributes, 28
- likelihood-ratio, 23, 26, 43
- loss, 88
- low back pain, 57
- Lyme disease, 57

- magnetic resonance imaging, 55, 87, 111
- manic-depression, 58
- meningitis, 26, 42, 43, 56, 57, 119
- meta-analysis, 21
- Monte Carlo simulation, 38, 75
- multi-infarct dementia, 113
- multiple sclerosis, 54, 63, 113
- muscular dystrophy, 56

- normal pressure hydrocephalus, 112

- odds, 20
- outcome node, 16
- overview, 21

- path probability, 29
- perfect information, 23
- perfect test, 97
- plausible range, 20, 36
- polycystic kidney disease, 53
- posterior odds, 24
- predictive value, 42, 57
- prior odds, 24
- probability, 19
- probability judgment, 21
- proportional hazards regression, 130
- publication bias, 21

- quality adjusted life expectancy, 33, 51, 73, 83, 88, 104, 148

- Receiver operating characteristic, 27
- regret, 34
- risk-aversion, 32
- risk analysis, 29
- robustness, 36
- ROC-analysis, 27

ROC analysis
 receiver operating characteristic
ROC curves
 receiver operating characteristic

sensitivity, 27, 42, 51, 56, 91, 118
sensitivity analysis, 16, 21, 36, 39, 54, 63, 75, 84, 108, 148
 two-way, 37
specificity, 27, 42, 51, 56, 91, 118, 126
spinal muscular atrophy, 56
spinal stenosis, 57
standard reference gamble, 29, 30
subarachnoid haemorrhage, 53, 62, 64, 79, 101, 119, 128, 145
subjective expected utility, 12, 45, 48, 188
subjective probability, 22, 82, 87, 112
substitution probability, 31
sure thing, 30
survival, 33
syncope, 52
syphilis, 58, 113

temporal arteritis, 55
terminal node, 16
threshold
 analysis, 37
 value, 37
threshold analysis, 123, 159
time-trade-off, 31
toss-up, 52, 74
transferability, 49
transient ischaemic attacks, 64
transitivity, 30

utility, 29
Utility, 29
utility elicitation, 31
utility scale, 29

validation, 162
visual analog scaling, 31
visual evoked responses, 55

