

## **A New Selective Harmonic Elimination Pulse- Width and Amplitude Modulation (SHEPWAM) for Drive Applications**

**Ghoreishy, Hoda; Varjani, Ali Yazdian; Mohamadian, Mustafa; Farhangi, Shahrokh; Zhang, Zhe**

*Published in:*  
Proceedings of IECON 2013

*Publication date:*  
2013

[Link back to DTU Orbit](#)

*Citation (APA):*

Ghoreishy, H., Varjani, A. Y., Mohamadian, M., Farhangi, S., & Zhang, Z. (2013). A New Selective Harmonic Elimination Pulse- Width and Amplitude Modulation (SHEPWAM) for Drive Applications. In Proceedings of IECON 2013 IEEE.

## **DTU Library** Technical Information Center of Denmark

---

### **General rights**

Copyright and moral rights for the publications made accessible in the public portal are retained by the authors and/or other copyright owners and it is a condition of accessing publications that users recognise and abide by the legal requirements associated with these rights.

- Users may download and print one copy of any publication from the public portal for the purpose of private study or research.
- You may not further distribute the material or use it for any profit-making activity or commercial gain
- You may freely distribute the URL identifying the publication in the public portal

If you believe that this document breaches copyright please contact us providing details, and we will remove access to the work immediately and investigate your claim.

# A New Selective Harmonic Elimination Pulse-Width and Amplitude Modulation (SHE-PWAM) for Drive Applications

Hoda Ghoreishy<sup>1</sup>, Ali Yazdian Varjani<sup>2</sup>, Mustafa Mohamadian<sup>2</sup>, Shahrokh Farhangi<sup>3</sup> and Zhe Zhang<sup>4</sup>

<sup>1</sup>Dept. of Computer and Electrical Engineering, Babol Noshirvani University of Technology, Babol, Iran

<sup>2</sup>Dept. of Computer and Electrical Engineering, Tarbiat Modares University, Tehran, Iran

<sup>3</sup>Dept. of Computer and Electrical Engineering, Tehran University, Tehran, Iran

<sup>4</sup>Dept. of Electrical Engineering, Technical University of Denmark, Kgs. Lyngby, Denmark

**Abstract**— Compared to the conventional selective harmonic elimination-pulse width modulation (SHE-PWM), the selective harmonic elimination-pulse width and amplitude modulation (SHE-PWAM) control strategy results in significant improvements in the performance of CHB inverters. This fact is due to considering the optimization of the CHB dc sources' values along with the optimized switching angles. This paper proposes a new SHE-PWAM control strategy and its realization in a drive application. Analysis and simulations are carried out on a five-level CHB inverter. Experimental verifications also validate the simulation results. The results demonstrate that the new SHE-PWAM technique improves the performance of the drive compared to the conventional SHE-PWM.

**Index Terms**— Cascaded H-bridge inverters, PAM, PWAM, PWM, Selective harmonic elimination.

## I. INTRODUCTION

Harmonic elimination has been the focus of research for many years. If the converter switching loss is not a concern, the carrier based Pulse-Width Modulation (CBPWM) methods are very effective for controlling the inverter [1]. This is because the generated harmonics are beyond the bandwidth of the system and therefore these harmonics do not dissipate power.

In low-switching-frequency applications, the main object of the inverter's control strategy is generating a switching pulse pattern in such a way that a desired output fundamental is produced while specific selective harmonic levels are eliminated or eliminated. This PWM strategy is called Selective Harmonic Elimination PWM (SHE-PWM) [2]-[10] [13]-[17].

The order of the eliminated harmonics in the SHE-PWM strategy is proportional to the number of pulses. In other

words, eliminating more harmonics means more required pulses and consequently higher switching frequency and dissipated power. This is due to the fact that the only degree of freedom in this strategy is the pulse-width.

A novel Selective Harmonic Elimination control strategy combining both pulse-width and pulse-amplitude modulations (SHE-PWAM) in Cascaded H-bridge (CHB) is introduced in this paper. The SHE-PWAM uses the values of the CHB inverter's dc sources as degrees of freedom in addition to the switching angles. In the proposed strategy, the optimized values of the dc sources along with the optimized switching angles are obtained for different output fundamentals. In this way, more low-order harmonics are eliminated at the same switching frequency compared to the conventional SHE-PWM. Flexibility in the dc sources' values can be obtained using PWM-Rectifiers. As one of the main applications of the SHE-PWAM is considered to be in electrical drive systems, the proposed strategy is realized by means of a multilevel PWM rectifier-inverter system in a drive application. Experimental results show the improved stator currents and reduced torque ripple along with the elimination of more low order harmonics.

## II. THE NEW SHE-PWAM CONTROL STRATEGY

### A. Basic Principle

The typical three-phase structure of a CHB multilevel inverter with  $h$  cells per phase has been shown in Fig. 1. For this topology, the low-frequency multilevel output voltage for phase "a" is shown in Fig. 2. The  $\alpha_{i(i=1,2,\dots,h)}$  is the  $i^{\text{th}}$  switching angle and the  $V_{i(i=1,2,\dots,h)}$  is the  $i^{\text{th}}$  dc source value. The fourier series representation of the shown waveform gives:

$$V_{aN}(t) = \frac{1}{2} a_0 + \sum_{n=1}^{\infty} (a_n \cos \omega_n t + b_n \sin \omega_n t) \quad (1)$$

where  $\omega_n$  is  $n\frac{2\pi}{T}$ .

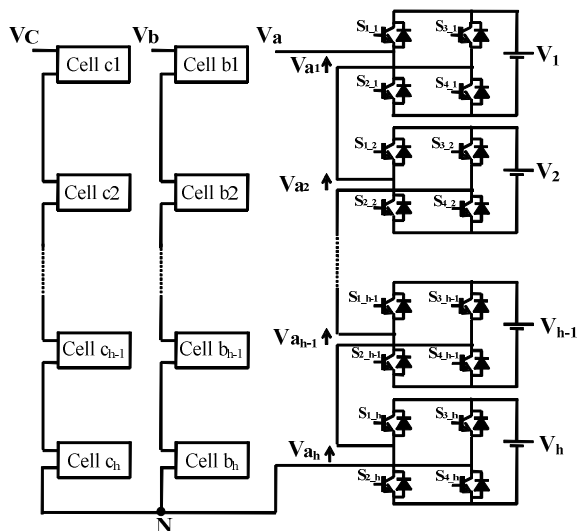

Fig. 1. The three phase CHB inverter topology.

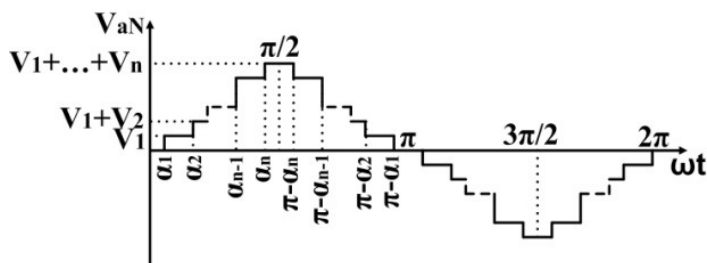

Fig. 2. Low frequency multilevel output voltage.

Due to the half-wave symmetry of the waveform, all  $a_n$  and even-numbered  $b_n$  coefficients are zero. The  $n^{\text{th}}$  harmonic can be eliminated if its related  $b_n$  coefficient is set equal to a minimum value. Moreover, in a three-phase system, triple- $n$  harmonics of the phase voltages are canceled out in the line voltages. Therefore, the low order harmonics to be eliminated are odd, non-triple- $n$  harmonics as 5, 7, 11, 13, 17....

The  $b_n$  odd coefficients are as:

$$b_n = \frac{4}{n\pi} (V_1 \cos(n\alpha_1) + (V_2) \cos(n\alpha_2) + \dots + (V_h) \cos(n\alpha_h)) \quad (2)$$

In the conventional CHB inverters, the  $V_i$  values are kept constant and are mainly defined as  $V_i = V_{dc}$  where  $V_{dc}$  is the dc link voltage. So, the  $b_n$  coefficients will be as:

$$b_n = \frac{4V_{dc}}{n\pi} (\cos(n\alpha_1) + \cos(n\alpha_2) + \dots + \cos(n\alpha_h)) \quad (3)$$

In the proposed SHE-PWAM control strategy, the values of

the inverter dc sources have been used as extra degrees of freedom in addition to the switching angles. In other words, keeping the  $V_i$  values constant is no longer a limitation bond in solving the equations obtained from (2). On the contrary, each  $V_i$  value can vary between 0 and  $V_{dc}$  increasing the equations and the degrees of freedom from (h) to (2h). It means that by solving the resultant equations, (h) optimized  $V_i$  values can be found along with the optimized angles. In this way, more low order, odd, non-triple- $n$  harmonics contents are eliminated compared to the conventional SHE-PWM control strategy ( $6n-1$  for the odd and even ( $n$ )) without any additional cost imposing. The main challenge in applying the SHE-PWAM control strategy to the CHB inverter under different modulation indices is the necessity of variable dc sources. In other words, the proposed sources' values should be capable of changing with an acceptable dynamic and at a specific time. The most appropriate option for the realization of the variable dc sources is the use of a PWM-rectifier configuration. This is due to the fact that in a variety of applications using low frequency control strategies, such as active power filters and electrical drives, power regeneration is inevitable. To satisfy these conditions the existence of controllable rectifiers, including thyristor rectifiers and PWM rectifiers, is necessary (Fig. 3). However, the switching frequency in thyristor rectifiers is equal to the line frequency, which distorts the input current waveform. Also these rectifiers are not able to correct the input power factor to near unity values. On the contrary, PWM-rectifiers are able to correct the input power factor and improve the input current waveform along with the dc source control and power regeneration capabilities. As one of the main applications of the SHE-PWAM is considered to be in electrical drive systems, the proposed strategy is realized by means of a multilevel PWM rectifier-inverter system in a drive application.

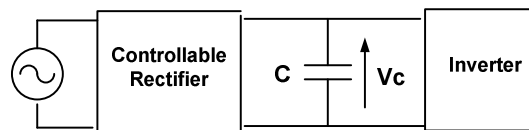

Fig. 3. Use of controllable rectifiers realizing variable dc sources.

### III. SIMULATION ANALYSIS

In this section, the novel SHE-PWAM control strategy has been applied to a five-level CHB inverter ( $h=2$ ). From equation (3), ( $2h=4$ ) equations are obtained in terms of the unknown  $\alpha_1, \alpha_2$  and  $V_1, V_2$  which are degrees of freedom in solving the proposed equations. Naturally, the first equation is for setting the output voltage fundamental to  $m_a \times 2V_{dc}$  ( $m_a$  is the amplitude modulation index) and the other equations are for eliminating the low order harmonics. Solving these

equations, the output voltage fundamental is controlled and the 5<sup>th</sup>, 7<sup>th</sup> and 11<sup>th</sup> harmonic contents are eliminated.

Fig. 4 shows the  $V_1$  and  $V_2$  p.u. values versus  $m_a$  for the five-level inverter. As mentioned before, these values are constant and equal to 1 p.u. (maximum dc link p.u. voltage) in the conventional SHE-PWM techniques. Each  $m_a$  is a measure of the inverter output voltage fundamental.

Fig. 5 shows the optimized switching angles versus  $m_a$  for the five-level inverter. In order to show the novel SHE-PWAM capability in eliminating more low order harmonics, the normalized contents of the 7<sup>th</sup> and 11<sup>th</sup> harmonics (i.e.  $\sqrt{(b_7/b_1)^2 + (b_{11}/b_1)^2}$ ) have been depicted in Fig. 6. Again, it should be noted that this improvement is due to increasing degrees of freedom of the five-level CHB output waveform equation from two to four. The two extra degrees of freedom are used to eliminate the 7<sup>th</sup> and 11<sup>th</sup> harmonic contents.

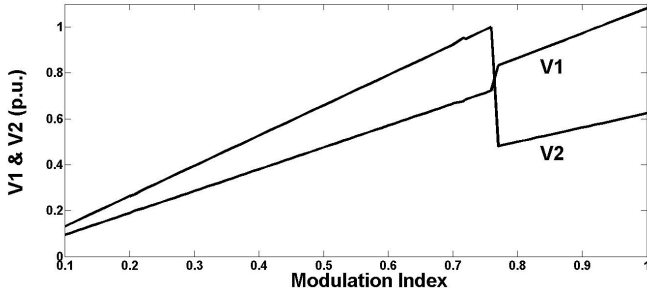

Fig. 4.  $V_1$  and  $V_2$  voltage values versus  $m_a$  in SHE-PWAM.

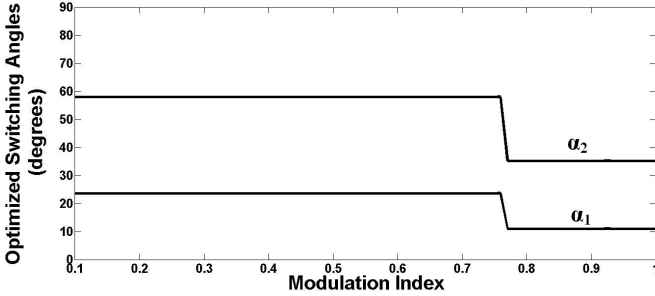

Fig. 5. Optimized switching angles versus  $m_a$  in SHE-PWAM.

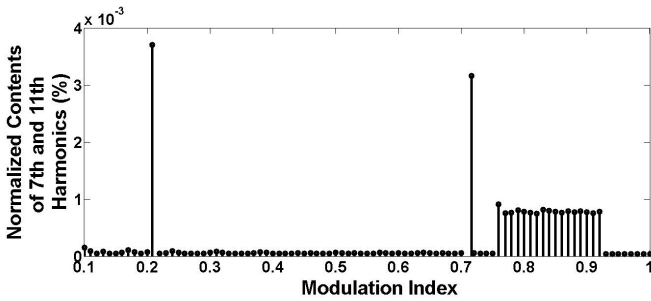

Fig. 6. Normalized contents of the 7<sup>th</sup> and 11<sup>th</sup> harmonics in SHE-PWAM.

#### IV. EXPERIMENTAL RESULTS

A low power prototype of a five-level CHB was developed to validate the theoretical and simulation results. As was mentioned before, the variable dc sources' values are provided using a PWM-rectifier. The maximum level of the separate dc sources and the output frequency are 155v and 50 Hz respectively. Load is a 300W, 380v, 50 Hz induction motor with its power factor equal to 0.77. A hardware platform based on a TMS320F28335 digital signal processor is used to control the system.

The control block diagram of the prototype has been shown in Fig. 7. The open loop volts/Hz control is used here for the induction motor which is a popular method of speed control because of its simplicity. The motor angular frequency  $\omega_e^*$  is the primary control variable and  $m_a$  is directly generated from it. Open-loop volts/Hz control is used with low-dynamics applications such as pumps or fans where a small variation of motor speed with load is tolerable. Since the SHE techniques are inherently low dynamic strategies, they can be used with the mentioned applications.

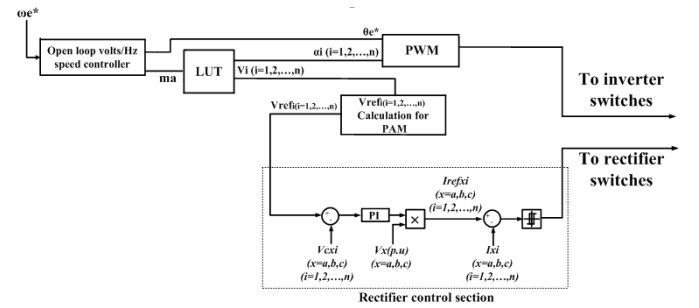

Fig. 7. Control block diagram of Fig. 1.

$m_a$  is the look-up table (LUT) input parameter to choose the angles and the voltage level values. The selected angles along with the angle  $\theta_e^*$  enter the PWM block where the times for the gate drive pulses are calculated and applied to the inverter switches. Referring to Fig. 7, the selected voltage level values are the capacitor voltages references ( $V_{refi}$ ). These are then entered into the rectifier control section. The control technique of this section is based on the conventional hysteresis current control. In this technique, as shown in Fig. 7, capacitor voltages ( $V_{cxi}$ ) are independently compared with their proper reference values ( $V_{refi}$ ) producing separate error signals. These errors are then passed through PI controllers to generate the amplitude of the reference currents for rectifier cells. These amplitudes are multiplied by per unit sinusoidal waveforms which are in-phase with the input voltage  $V_x$ , in order to provide the unity power factor. So, individual reference currents for each rectifier cell will be produced. The rectifier cells' sampled currents ( $I_{sxi}$ ) are compared to their references and their errors go through hysteresis band to produce proper gate signals for the CHB rectifier switches. Hence, each

capacitor voltage is controlled separately and different current values do not cause any problem in the system control.

In order to show the PAM realization in the output voltage, the  $V_{an}$  and  $V_{bn}$  voltages have been represented in Fig. 8 which their envelopes obviously shows the PAM realization. The variation of capacitors' voltages due to the change in  $m_a$  can be seen from these envelopes.

Validating the PWM-rectifier capability in providing the unity power factor, input voltage and current of phase A have been measured from their related sensors output and shown in Fig. 9. The measured waveforms are in-phase providing the unity power factor for the system.

In order to compare the novel SHE-PWAM with the conventional SHE-PWM, some further measurements have been extracted. Based on the data measured from the hardware, the following parameters have been calculated in both novel and conventional cases:

#### A. Output current harmonics contents

Fig. 10 shows the stator three-phase currents after applying the nominal torque at rated speed and frequency in both cases. In order to compare the most important harmonic contents of

the proposed currents, Fig. 11 shows their 5<sup>th</sup>, 7<sup>th</sup> and 11<sup>th</sup> harmonic magnitudes as percentages of the fundamental current. The SHE-PWAM control strategy is capable of eliminating 5<sup>th</sup>, 7<sup>th</sup> and 11<sup>th</sup> harmonics of the output voltage while the SHE-PWM is only able to eliminate the 5<sup>th</sup> harmonic content. This improvement obtained from the novel SHE-PWAM leads to a more qualified load current which can be concluded by comparing figures 11.a and 11.b. Referring these figures, both strategies have eliminated the 5<sup>th</sup> harmonic but only the SHE-PWAM is able to eliminate the 7<sup>th</sup> and 11<sup>th</sup> harmonic contents due to its two extra degrees of freedom. This improvement in the stator current stands for an improvement in the motor input voltage using the novel SHE-PWAM.

#### B. Torque ripple

Improving the current harmonic contents leads to a considerable reduction in the torque ripple. Fig. 12 compares this ripple in both cases.

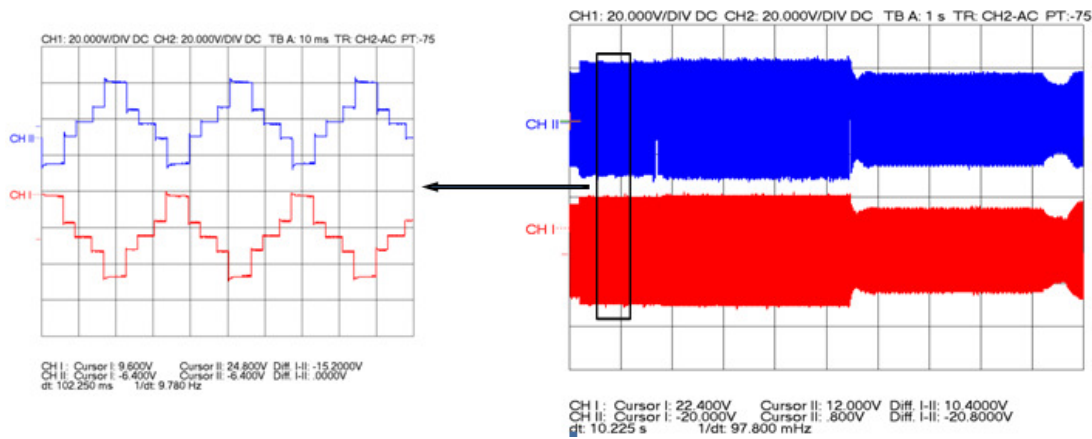

Fig. 8. Experimental  $V_{an}$  and  $V_{bn}$  phase voltages.

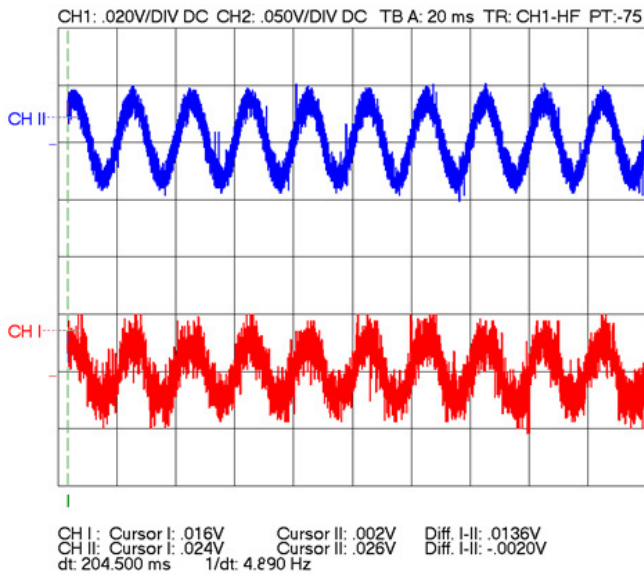

Fig. 9. Experimental input voltage and current of phase A.

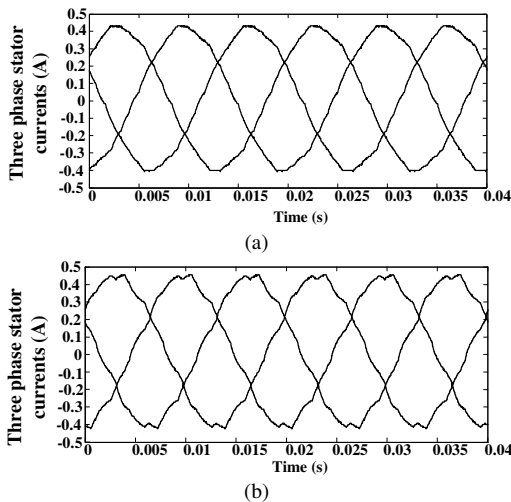

Fig. 10. Experimental stator three-phase currents after applying the nominal torque at rated speed and frequency a) SHE-PWAM b) SHE-PWM.

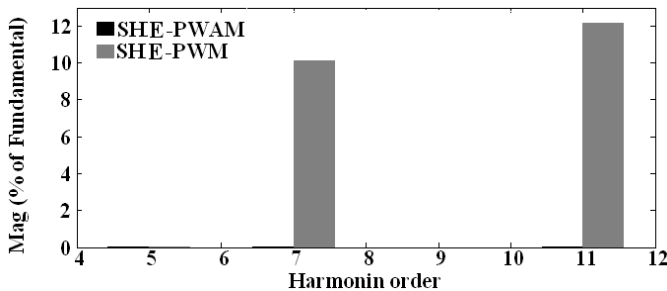

Fig. 11. 5th, 7th and 11th harmonics magnitude in both cases.

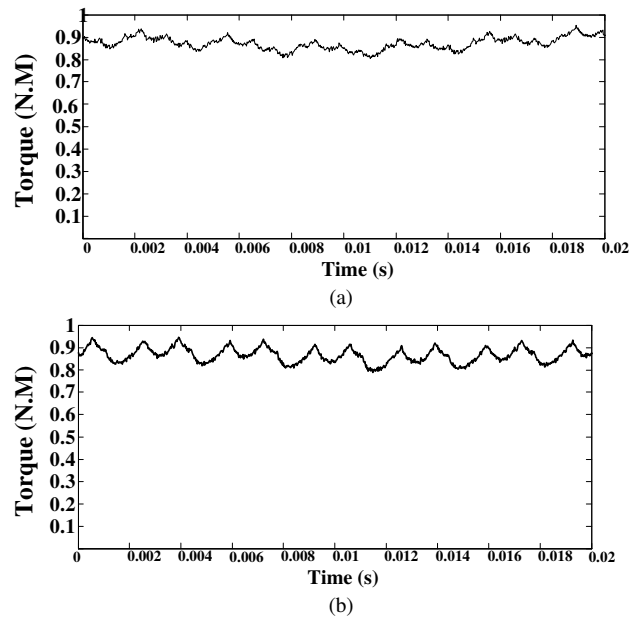

Fig. 12. Experimental torque a) SHE-PWAM b)SHE-PWM.

## V. Conclusion

A new SHE-PWAM control strategy has been proposed for CHB inverters in drive applications. Flexibility in the dc sources' values which can be obtained using PWM-Rectifiers increases system degrees of freedom to eliminate more selected harmonics. This fact leads to an improved system performance such as eliminating more stator currents harmonic contents and torque ripple. Unlike the conventional SHE-PWM, these advantages are obtained without increasing the switching frequency and its related power dissipation. Simulation and experimental results verifies the superiority of the novel SHE-PWAM over the conventional SHE-PWM.

## VI. REFERENCES

- [1] J. N. Chiasso, L. M. Tolbert, K. J. McKenzie and Z. Du, "A complete solution to the harmonic elimination problem", *IEEE Trans. on Power Electronics*, vol. 19, no. 2, pp. 491-499, March 2004.
- [2] J. I. Guzman, J. R. Espinoza, L. A. Moran and G. Joos, "Selective harmonic elimination in multimodule three-phase current-source converters," *IEEE Trans. on Power Electronics*, vol. 25, no. 1, pp. 44-53, Jan 2010.
- [3] A. Kavousi, B. Vahidi, R. Salehi, M. K. Bakhshizadeh, N. Farokhnia and S. H. Fathi, "Application of the Bee algorithm for selective harmonic elimination strategy in multilevel inverters," *IEEE Trans. on Power Electronics*, vol. 27, no. 4, pp. 1689-1696, April 2012.
- [4] K. Sundareswaran, K. Jayant, and T. N. Shanavas, "Inverter harmonic elimination through a colony of continuously exploring ants," *IEEE Trans. on Industrial Electronics*, vol. 54, no. 5, pp. 2558-2865, Oct. 2007.

- [5] V. G. Agelidis, A. Balouktsis and I. Balouktsis, "On attaining multiple solutions of selective harmonic elimination PWM three-level waveforms through function minimization", *IEEE Trans. on Industrial Electronics*, vol. 55, no. 3, pp. 996-1004, March 2008.
- [6] M.S.A. Dahidah and V.G. Agelidis, "Selective harmonic elimination PWM control for cascaded multilevel voltage source converters: a generalized formula," *IEEE Trans. on Power Electron.*, vol. 23, no. 4, pp. 1620-1630, Jul. 2008.
- [7] V.G. Agelidis, A.I. Balouktsis and M.S.A. Dahidah, "A five-level symmetrically defined selective harmonic elimination PWM strategy: analysis and experimental validation," *IEEE Trans. on Power Electronics*, vol. 23, no. 1, pp. 19-26, Jan. 2008.
- [8] G.S. Konstantinou, M.S.A. Dahidah and V.G. Agelidis, "Solution trajectories for selective harmonic elimination pulse-width modulation for seven-level waveforms: analysis and implementation," *IET Power Electron.*, vol. 5, no. 1, pp. 22-30, 2012.
- [9] J. Wang and D. Ahmadi, "A precise and practical harmonic elimination method for multilevel inverters," *IEEE Trans. Industry Application*, vol. 46, no. 2, pp. 857-865, March 2010.
- [10] D. Ahmadi and J. Wang, "Selective harmonic elimination for multilevel inverters with unbalanced DC inputs," in *Proc. IEEE Vehicle Power and Propulsion Conference (VPPC)*, pp. 773-778, Sep. 2009.
- [11] J. Napoles, J. I. Leon, R. Portillo, L. G. Franquelo and M. A. Aguirre, "Selective harmonic elimination technique for high power converters", *IEEE Trans. on Industrial Electronics*, vol. 57, no. 7, pp. 2315-2323, July. 2010.
- [12] W. Fei, X. Du and B. Wu, "A generalized half-wave symmetry SHE-PWM formulation for multilevel voltage inverters," *IEEE Trans. on Industrial Electronics*, vol. 57, no. 9, pp. 3030-3038, Sep. 2010.
- [13] Y. Zhang, Z. Zhao and J. Zhu, "A hybrid PWM applied to high-power three-level inverter-fed induction-motor drives," *IEEE Trans. on Industrial Electronics*, vol. 58, no. 8, pp. 3409-3420, Aug. 2011.
- [14] H. Taghizadeh and M. Tarafdar Hagh, "Harmonic elimination of cascade multilevel inverters with nonequal DC sources using particle Swarm optimization," *IEEE Trans. on Industrial Electronics*, vol. 57, no. 11, pp. 3678-3684, Nov. 2010.
- [15] J. A. Pontt, J. R. Rodriguez, A. Liendo, P. Newman, J. Holtz and J. M. San Martin, "Network-friendly low-switching-frequency multipulse high-power three-level PWM rectifier," *IEEE Trans. on Industrial Electronics*, vol. 56, no. 4, pp. 1254-1262, April. 2009.
- [16] D. Ahmadi, K. Zou, C. Li, Y. Huang and J. Wang, "A universal selective harmonic elimination method for high-power inverters," *IEEE Trans. on Power Electronics*, vol. 26, no. 10, pp. 2743-2752, Oct. 2011.
- [17] S. Kouro, M. Malinowski, K. Gopakumar, J. Pou, L. G. Franquelo, B. Wu, J. Rodriguez, M. A. Perez and J. I. Leon, "Recent advances and industrial applications of multilevel converters," *IEEE Trans. on Industrial Electronics*, vol. 57, no. 8, pp. 2553-2580, Aug. 2010.