

129I record in the Taal Lake sediment, Philippines: Implication for global fallout of 129I in low latitude

Zhang, Luyuan; Hou, Xiaolin; Zhou, W.J.; Li, H.C.; Chen, N.; Fan, Y.K.; Liu, Q.; Fu, Y.C.

Published in:
Abstracts. Russian-Nordic Symposium on Radiochemistry

Publication date:
2013

Document Version
Publisher's PDF, also known as Version of record

[Link back to DTU Orbit](#)

Citation (APA):
Zhang, L., Hou, X., Zhou, W. J., Li, H. C., Chen, N., Fan, Y. K., ... Fu, Y. C. (2013). 129I record in the Taal Lake sediment, Philippines: Implication for global fallout of 129I in low latitude. In S. N. Kalmykov, V. G. Petrov, & A. Y. Romanchuk (Eds.), Abstracts. Russian-Nordic Symposium on Radiochemistry (pp. 153). IDEA PRINT.

DTU Library

Technical Information Center of Denmark

General rights

Copyright and moral rights for the publications made accessible in the public portal are retained by the authors and/or other copyright owners and it is a condition of accessing publications that users recognise and abide by the legal requirements associated with these rights.

- Users may download and print one copy of any publication from the public portal for the purpose of private study or research.
- You may not further distribute the material or use it for any profit-making activity or commercial gain
- You may freely distribute the URL identifying the publication in the public portal

If you believe that this document breaches copyright please contact us providing details, and we will remove access to the work immediately and investigate your claim.

M. V. Lomonosov Moscow State University



Russian–Nordic Symposium
on Radiochemistry

Abstracts



21–24 October 2013

Moscow, Russia

ORGANIZED AND SPONSORED BY

**Lomonosov Moscow State
University**



**Russian Foundation for Basic
Research**

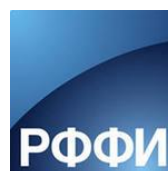

Russian Academy of Sciences



Triskem International



**Interdisciplinary Scientific Council on Radiochemistry at
the Presidium of Russian Academy of Sciences and
the State Corporation "Rosatom"**



TECHNICAL PARTNERS

UniFest Congress



LLC "EcoNanoSystems"



The First Russian-Nordic Symposium on Radiochemistry

The First Russian-Nordic Symposium on Radiochemistry “RNSR-2013”: Abstracts, 21-24 October 2013, Moscow, Russia: IDEA PRINT, 2013 – 200 p.

This book contains abstracts contributing to the First Russian-Nordic Symposium on Radiochemistry “RNSR-2013” organized by Lomonosov Moscow State University, Russian Academy of Sciences, Interdepartmental Scientific Council on Radiochemistry at the Presidium of Russian Academy of Sciences and the State Corporation “Rosatom” and Russian Foundation for Basic Research. RNSR-2013 is the first Symposium in this series that is originated from Russian-Finish Symposium on Radiochemistry series that started in 1987. RNSR unites together radiochemists from Russia and Nordic countries: Finland, Sweden, Norway and Denmark. It covers various topics including basic radiochemistry, nuclear fuel cycle, spent nuclear fuel and nuclear waste management and disposal, radioecology and environmental radioactivity, nuclear medicine and isotope production, radioanalytical chemistry.

For specialists in radiochemistry, radioecology, nuclear fuel cycle and nuclear medicine.

Edited by: Prof. S.N. Kalmykov, Dr. V.G. Petrov and A.Yu. Romanchuk.

INTERNATIONAL SCIENTIFIC COMMITTEE

Boris Myasoedov (IPCE RAS, RU) – honorary chairman

Gennady Badun (MSU, RU)

Christian Ekberg (Chalmers, SE)

Konstantin German (IPCE, RU)

Xiaolin Hou (TU, DK)

Mats Jonsson (KTH, SE)

Stepan Kalmykov (MSU, RU)

Jukka Lehto (UoH, FI)

Jon Petter Omtvedt (UiO, NO)

Brit Salbu (UMB, NO)

Lindis Skipperud (UMB, NO)

Igor Smirnov (Radium Inst., RU)

Olof Solin (UTU, FI)

Ivan Tananaev (Mayak, RU)

Yuri Kulyako (GEOKHI, RU)

Yuri Vlasov (StPSU, RU)

SYMPOSIUM CO-CHAIRS

Stepan Kalmykov

Jukka Lehto

LOCAL ORGANIZING COMMITTEE

Maria Chernysheva

Olga Dubovaya

Bayirta Egorova

Natalya Kuzmenkova

Vladimir Petrov

Anna Romanchuk

Irina Vlasova

CONTENTS

1. FUNDAMENTAL RADIOCHEMISTRY AND NUCLEAR CHEMISTRY	1
SYNTHESIS OF DIETHYLDITRITIUMSTANNANE	3
<i>A.A. Alferova, T.A. Kochina, E.N. Sinotova, V.V. Avrorin</i>	
REFINEMENT OF THE ²²⁵ Ac HALF-LIFE	4
<i>A.S. Bolonkin, A.V. Dunin</i>	
THE PERTECHNETATE-ION PRECIPITATION IN NITRIC ACID SOLUTIONS WITH O-PHEN COMPLEX OF IRON (II) NITRATE	5
<i>T.A. Boytsova, V.A. Babain, A.A. Murzin</i>	
EXAMINATION OF THE RADIUM-LEAD START COMPOSITION FOR ²²⁶ Ra IRRADIATION	6
<i>P.S. Butkalyuk, I.L. Butkalyuk, I.E. Vlasova, S.V. Tomilin, R.A. Kuznetsov</i>	
RADIOGRAPHIC EXAMINATION OF CURIUM ALLOYS WITH COBALT, IRON AND CARBON	7
<i>T.A. Chernakova, V.M. Radchenko</i>	
SCINTILLATION PHASE APPLICATION IN PHYSICAL CHEMICAL STUDIES: ADVANTAGES AND LIMITATIONS	8
<i>M.G. Chernysheva, G.A. Badun</i>	
SUPERHEAVY ELEMENTS IN THE PERIODIC TABLE: A BIRD'S EYE VIEW THROUGH "CHEMICAL GRAPHS"	9
<i>Yu.A. Demidov, A.V. Zaitsevskii</i>	
ROLE OF TEMPERATURE AND HYDROGEN CONTENT IN [¹¹ C]CH ₄ PRODUCTION	10
<i>S. Helin, E. Arponen, J. Rajander, J. Aromaa, O. Solin</i>	
CHEMILUMINESCENT SOLID-PHASE REACTIONS OF URANIUM(IV,VI) HYDROPHOSPHATES WITH XENON DIFLUORIDE	11
<i>A. Itullina, G. Masyagutova, A. Mamykin</i>	
CHEMILUMINESCENT REACTIONS OF TERBIUM(III) AND EUROPIUM(III) SULFATES WITH XENON DIFLUORIDE	12
<i>A. Itullina, G. Masyagutova, A. Mamykin</i>	
LYSOZYME – ZWITTERIONIC SURFACTANT ADSORPTION AT THE AQUEOUS/OCTANE INTERFACE AS STUDIED BY SCINTILLATION PHASE METHOD	13
<i>R.A. Ivanov, O.A. Soboleva, M.G. Chernysheva, G.A. Badun</i>	
MICROCALORIMETRIC TITRATION AS A PERSPECTIVE METHOD FOR LIQUID-LIQUID EXTRACTION STUDIES	14
<i>M.D. Karavan, I.V. Smirnov, V. Hubscher-Bruder, F. Arnaud-Neu, V.I. Kalchenko</i>	
NEW THIACALIX[4]ARENES AS EXTRACTANTS FOR METAL CATIONS	15
<i>M.D. Karavan, I.V. Smirnov, S.G. Kharchenko, A.B. Drapailo, V.I. Kalchenko, S.V. Shishkina, O.V. Shishkin</i>	
RATE OF THE EXTRACTION REE AT VIBRATION ON A DYNAMIC INTERFACIAL LAYER	16
<i>N.F. Kizim, E.N. Golubina, A.M. Chekmarev</i>	
COPRECIPITATION OF RADIONUCLIDE MICROQUANTITIES ON CHITOSANS OF DIFFERENT MOLECULAR MASSES IN SOLUTIONS	17
<i>S.A. Kulyukhin, I.E. Veleshko, A.N. Veleshko</i>	
A NEW FORMULATION OF EFFECTIVE STATES OF "ATOMS IN COMPOUNDS". APPLICATION TO STUDY HYPERFINE STRUCTURES AND CHEMICAL SHIFTS OF X-RAY EMISSION LINES	18
<i>Yu.V. Lomachuk, L.V. Skripnikov, A.V. Titov</i>	
SPECIATION OF HEPTAVALENT TECHNETIUM IN INORGANIC ACIDS AND PERCHLORATE MEDIA	19
<i>A.Ya. Maruk, F. Poineau, P.F. Weck, A. Kirakosyan, W. Lukens, B. Burton-Pye, D.B. Rego, I. Denden, E.V. Johnstone, A.P. Sattelberger, M. Fattahi, L. Francesconi, K.R. Czerwinski, K.E. German</i>	

The First Russian-Nordic Symposium on Radiochemistry

TECHNETIUM AND RHENIUM PENTACARBONYL PERCHLORATES AS PRECURSORS FOR HIGHER CARBONYL COMPLEXES OF TECHNETIUM AND RHENIUM <i>A.E. Miroslavov, V.V. Gurzhiy, M.Yu. Tyupina, A.A. Lumpov, G.V. Sidorenko, Yu.S. Polotskii, D.N. Suglobov</i>	20
CHEMISTRY OF SUPERHEAVY ELEMENTS THROUGH RELATIVISTIC ELECTRONIC STRUCTURE MODELING <i>N.S. Mosyagin, Yu.A. Demidov, L.V. Skripnikov, A.A. Rusakov, A.V. Zaitsevskii, A.V. Titov</i>	21
Np(V) SOLUBILITY IN NaCl AND MgCl ₂ SOLUTIONS <i>V.G. Petrov, X. Gaona, D. Fellhauer, J. Rothe, K. Dardenne, S.N. Kalmykov, M. Altmaier</i>	22
CURIUM-TECHNETIUM COMPLEX OXIDE <i>E.M. Pichuzhkina, S.V. Tomilin</i>	23
STUDY OF CERIUM OXIDE NANOPARTICLES SOLUBILITY USING A RADIOACTIVE ISOTOPE ¹⁴¹ Ce <i>T.V. Plakhova, A.Yu. Romanchuk, V.K. Ivanov, D. Shuh, S.N. Kalmykov</i>	24
TECHNETIUM BINARY HALIDES <i>F. Poineau, E.V. Johnstone, A.P. Sattelberger, K.R. Czerwinski</i>	25
AMERICIUM ALLOYS WITH GOLD AND COPPER <i>V.M. Radchenko, M.A. Ryabinin, T.A. Chernakova, S.V. Tomilin, E.M. Pichuzhkina</i>	26
ATOMIC TRITIUM PROBE IN THE INVESTIGATION OF IONIC SURFACTANT ADMIXTURES INFLUENCE ON LYSOZYME ADSORPTION LAYER <i>I.A. Razzhivina, M.G. Chernysheva, A.L. Ksenofontov, O.A. Soboleva, G.A. Badun</i>	27
NUCLEAR-CHEMICAL SYNTHESIS OF NEW NUCLEOGENIC CATIONS – PRECURSORS FOR UNKNOWN BIOLOGICALLY ACTIVE HETEROCYCLIC DERIVATIVES <i>N.E. Shchepina, V.V. Avrorin, G.A. Badun</i>	28
REACTIVITY OF TECHNETIUM(I) TETRACARBONYL COMPLEXES: EXPERIMENTAL AND QUANTUM-CHEMICAL STUDIES <i>G.V. Sidorenko, A.E. Miroslavov, D.A. Maltsev, A.A. Lumpov, M.Yu. Tyupina, Yu.S. Polotskii, D.N. Suglobov</i>	29
XPS INVESTIGATION OF PuO ₂ <i>Yu.A. Teterin, K.I. Maslakov, M.V. Ryzhkov, A.Yu. Teterin, K.E. Ivanov, V.G. Petrov, D.A. Enina, S.N. Kalmykov</i>	30
XPS STRUCTURE STUDY OF NpO ₂ <i>Yu.A. Teterin, K.I. Maslakov, M.V. Ryzhkov, A.Yu. Teterin, K.E. Ivanov, V.G. Petrov, D.A. Enina, S.N. Kalmykov</i>	31
CHEMICAL SHIFTS OF X-RAY EMISSION SPECTRA IN HEAVY-ATOM MOLECULES AND SOLIDS: A NEW METHOD FOR DESCRIBING THE STATE OF ATOMS IN COMPOUNDS <i>A.V. Titov, Yu.V. Lomachuk, A.V. Zaitsevskii, R.V. Bogdanov</i>	32
RECRYSTALLIZATION OF RADIUM-223 WITH BARIUM SULPHATE <i>N. Torapava, C. Ekberg, H. Ramebäck, E. Curti</i>	33
COBALT RADIONUCLIDE SPECIATION IN AQUEOUS SOLUTION <i>V.V. Torapava, A.V. Radkevich</i>	34
THE INFLUENCE OF NICKEL(II) AND CALCIUM(II) ON EUROPIUM(III) SORPTION AT VARIOUS OXIDE MINERALS WITH DIFFERENT SURFACE PROPERTIES <i>S. Virtanen, J. Knuutinen, N. Huittinen, J. Lehto</i>	35
HIGHER OXIDES OF EARLY TRANSURANIUM ELEMENTS: RELATIVISTIC MODELING OF MOLECULAR STRUCTURES <i>A.V. Zaitsevskii, N.S. Mosyagin, A.V. Titov, Yu.M. Kiselev</i>	36

2. NUCLEAR FUEL CYCLE, NUCLEAR WASTE TREATMENT AND DISPOSAL	37
THE BEHAVIOR OF THE BETA-RADIOACTIVE FISSION PRODUCTS IN FAST NEUTRON IRRADIATED URANIUM-PLUTONIUM NITRIDE NUCLEAR FUEL <i>A.V. Androsov, G.S. Bulatov, K.N. Gedgovd, D.Yu. Lyubimov</i>	39
SYNTHESIS, MICROSTRUCTURE AND PHYSICAL-MECHANICAL PROPERTIES OF MONAZITE-TYPE CERAMICS FOR THE CONDITIONING OF MINOR ACTINIDES <i>Y.A. Arinicheva, S. Neumeier, A.A. Bukaemskiy, F. Brandt, G. Modolo, D. Bosbach</i>	40
EFFECT OF IRRADIATION ON THE PARAMETERS OF GAS EVOLUTION DURING THERMOLYSIS OF 30% SOLUTIONS OF TRIBUTYLPHOSPHATE <i>E.V. Belova, Z.V. Dzhivanova, A.V. Rodin, B.F. Myasoedov</i>	41
THERMAL STABILITY OF THE TWO-PHASE MIXTURES OF RADIATION-DEGRADED TRIBUTYLPHOSPHATE IN PARAFFINIC HYDROCARBONS WITH NITRIC ACID IN ISOCHORIC CONDITIONS <i>E.V. Belova, A.V. Rodin, E.R. Nazin, B.F. Myasoedov</i>	42
THERMOCHEMICAL TRANSFORMATIONS OF U-234 AND U-238 ISOTOPES IN BRITHOLITE <i>R.V. Bogdanov, M.I. Skriplev</i>	43
THE MOBILE COMPLEX ON PURIFICATION OF LIQUID RADIOACTIVE WASTE <i>N.G. Firsin, S.N. Florya, A.I. Kostylev, I.S. Ledovskoy, A.V. Naumov</i>	44
THE WAYS OF TECHNETIUM LOCALIZATION AT THE SNF REPROCESSING <i>N.D. Goletsky, B.Ya. Zilberman, A.S. Kudinov, S.A. Rodionov, D.V. Ryabkov, Yu.S. Fedorov</i>	45
TECHNOLOGY OF PLASMA TREATMENT OF SOLID RADIOACTIVE WASTE <i>V.A. Gorbunov, M.A. Polkanov, F.A. Lifanov</i>	46
BIODEGRADATION OF CEMENT MATRIX DURING LONG-TERM STORAGE OF RADIOACTIVE WASTE <i>O.A. Gorbunova</i>	47
HIGH-SILICA ADDITIVES DURING CEMENTATION OF RADIOACTIVE WASTE <i>O.A. Gorbunova, S.E. Vinokurov</i>	48
REPRO – THE FIRST RADIOACTIVE EXPERIMENT AT ONKALO UNDERGROUND FACILITY <i>K. Helariutta, J. Ikonen, M. Siitari-Kauppi, M. Voutilainen, P. Andersson, J. Byegård, K. Nilsson, M. Skälberg, A. Poteri, P. Kekäläinen, J. Timonen, K. Kemppainen, I. Aaltonen, L. Koskinen</i>	49
BIOGEOCHEMICAL BARRIER CONCEPT IN CONSERVATION OF RW SURFACE STORAGEES <i>V.A. Ilin, V.E. Tregubova, A.V. Safonov, E.V. Zakharova</i>	50
SUBLIMATION PURIFICATION OF ⁹⁹ Mo PREPARATION BY LASER TREATMENT OF THE REACTION CELL INTERNAL COATING <i>I.A. Istomin, V.P. Medvedev</i>	51
RADIATION INDUCED DISSOLUTION OF SPENT NUCLEAR FUEL <i>M. Jonsson</i>	52
ADVANCED SEPARATION TECHNIQUES FOR RADIONICKEL <i>M. Kaipainen, R. Koivula</i>	53
“STATION NUCLEAR FUEL CYCLE BALANCE MODEL” SOFTWARE PACKAGE <i>V.A. Kashcheev, T.V. Podymova, O.V. Schmidt, V.A. Tkachenko, S.G. Tretyakova</i>	54
THE USE OF ROCK CASTING CONTAINERS FOR STORAGE OF GLASS WASTE PRODUCTS <i>V.B. Krapukhin, V.V. Kulemin, E.P. Krasavina, V.A. Lavrikov, S.A. Kulyukhin</i>	55
SPIRAL FILTERING ELEMENT AS THE BASIS OF THE FILTRATION INSTALLATIONS FOR REMOVAL OF THE SOLID RADIOACTIVE IMPURITIES FROM GAS AND LIQUID PHASES <i>V.B. Krapukhin, V.V. Kulemin, V.A. Lavrikov, S.A. Kulyukhin</i>	56

The First Russian-Nordic Symposium on Radiochemistry

CLEARING OF THE LOW RADIOACTIVE LIQUID WASTE FROM OILS AND OIL PRODUCTS BY UV-RADIATION AT THE NUCLEAR POWER PLANT <i>V.V. Kulemin, V.B. Krapukhin, V.A. Lavrikov, S.A. Kulyukhin</i>	57
SORPTION OF ^{60}Co MICROQUANTITIES ON LAYERED DOUBLE HYDROXIDES FROM AQUEOUS SOLUTIONS <i>S.A. Kulyukhin, E.P. Krasavina, I.A. Rumer</i>	58
CONVERSION OF I_2 IN IONIC FORMS ON THE COMPOSITE MATERIALS "FIZKHIMIN" TM IN WATER COOLANT AT NUCLEAR POWER PLANTS <i>S.A. Kulyukhin, L.V. Mizina, I.A. Rumer</i>	59
MATRIX DIFFUSION OF RADIONUCLIDES ON A DRILL CORE SAMPLE FROM ONKALO, OLKILUOTO <i>J. Kuva, M. Voutilainen, P. Hölttä, P. Kekäläinen, J. Timonen, M. Siitari-Kauppi, K. Hänninen, J. Häkkinen, K. Helariutta, L. Koskinen</i>	60
URANIUM SPECIATION IN VITRIFIED INCINERATOR SLAGS <i>G.A. Malinina, S.V. Stefanovsky</i>	61
THE URANIUM DECONTAMINATION FACTORS FOR SOME RADIONUCLIDES DURING SNF REPROCESSING AT THE RADIOCHEMICAL FACTORY OF FSUE "PA "MAYAK" <i>A.B. Melentev, A.N. Mashkin, K.E. German</i>	62
BEHAVIOR OF $^{137}\text{Cs}^{131}\text{I}$ AND $^{137}\text{CsOH}$ RADIOAEROSOLS IN THE ELECTROSTATIC FIELD <i>N.B. Mikheev, V.V. Kulemin, V.A. Lavrikov, I.V. Melikhov, I.A. Rumer, S.A. Kulyukhin</i>	63
NITRIC ACID ADDUCTS FORMATION DURING BARIUM AND STRONTIUM NITRATES CRISTALLIZATION FROM NITRIC ACID MEDIA AND THEIR COPRECIPITATION <i>N.E. Mishina, B.Ya. Zilberman, A.A. Lumpov, T.I. Koltsova, D.V. Ryabkov</i>	64
CERAMIC WASTE FORMS FOR THE CONDITIONING OF MINOR ACTINIDES <i>S. Neumeier, A.A. Bukaemskiy, F. Brandt, S. Finkeldei, Y. Arinicheva, G. Modolo, D. Bosbach</i>	65
IMMOBILISATION OF RADIOACTIVE OILS WITH THE USE OF THERMALLY EXPANDED GRAPHITE <i>A.V. Nikitin, I.A. Shestakov, Ya.V. Sergeecheva, E.A. Tyupina, A.B. Sazonov</i>	66
STUDYING THE EFFICIENCY OF THE REAGENT PROCESSING IN COMBINATION WITH FRACTIONATING FOR DECONTAMINATION OF SOILS <i>V.B. Nikolaevskiy, N.V. Klochkova, S.S. Batusov</i>	67
INFLUENCE OF INTERACTION TIME OF Cs^{137} , Sr^{90} AND Co^{60} WITH BACKFILL MATERIALS ON FORMS OF THESE ELEMENTS <i>E.E. Ostashkina, O.A. Burlaka, G.A. Varlakova</i>	68
SOLIDIFICATION OF NON-TECHNOLOGICAL WASTE WITH POLYMERS USAGE AT RADIUM INSTITUTE <i>Yu. Pokhitonov, V. Babain, M. Alyapyshev, D. Kelley</i>	69
ELECTROCHEMICAL DEPOSITION OF ACTINIDES FROM ORGANIC EXTRACTS CONTAINING DIPHENYL(DIBUTYL)-CARBAMOYLMETHYLPHOSPHINE OXIDE AND IONIC LIQUIDS <i>G.A. Pribylova, I.V. Smirnov, A.P. Novikov</i>	70
GRAPHENE OXIDE FOR EFFECTIVE RADIONUCLIDE REMOVAL FROM AQUEOUS SOLUTIONS <i>A.Yu. Romanchuk, A. Slesarev, J. Tour, S.N. Kalmykov</i>	71
ELECTROCHEMICAL DISSOLUTION OF Tc – Ru ALLOYS IN HNO_3 SOLUTION <i>K.V. Rotmanov, A.G. Maslennikov</i>	72
NEUTRINO EMISSION AND THE SAFETY OF NUCLEAR OBJECTS <i>G.B. Ryazantsev, I.N. Beckman, D.A. Minyaeva</i>	73
BIODESTRUCTION OF OIL-CONTAINING RW <i>A.V. Safonov, V.E. Tregubova</i>	74

The First Russian-Nordic Symposium on Radiochemistry

NPP LIQUID RADIOACTIVE WASTE TREATMENT WITH SELECTIVE EXTRACTION OF RADIONUCLIDES <i>A. Savkin</i>	75
EXTRACTION OF YTTRIUM BY NEW ORGANOPHOSPHORUS LIGAND <i>N.N. Senik, B.V. Egorova, S.N. Kalmykov, I.E. Nifant'ev</i>	76
RADIOCHEMICAL ISSUES OF CLOSED NUCLEAR FUEL CYCLE <i>A. Shadrin, K. Dvoyeglazov, V. Ivanov, V. Volk</i>	77
SUPPRESSION OF RADIOACTIVE SUBSTANCES IN AIR FILTERS <i>S.M. Shevchenko</i>	78
COMPARISON OF RADIONUCLIDE DIFFUSION COEFFICIENTS IN GLASSES, GLASS-CERAMICS, AND CERAMICS <i>S.V. Stefanovsky, I.A. Ivanov</i>	79
EXTRACTION OF ACTINIDES BY DIAMIDES OF 2,2'-DIPYRIDYL-6,6'-DICARBOXYLIC ACID <i>L.I. Tkachenko, M.Yu. Alyapyshev, V.A. Babain, N.E. Borisova</i>	80
RADIOCHEMISTRY AT THE LOVIISA NUCLEAR POWER PLANT <i>L. Togneri</i>	81
IMMOBILIZATION OF LONG-LIVED IODINE AFTER INCORPORATION INTO APATITE MATRICE <i>N. Torapava, C. Walther</i>	82
ESTIMATION OF LIQUID RADIOACTIVE WASTE DEGRADATION BEFORE SOLIDIFICATION POSSIBILITY <i>V.E. Tregubova, A.V. Safonov, O.A. Gorbunova</i>	83
TECHNETIUM AS A PERSPECTIVE FORM FOR IMMOBILIZATION INTO ENVIRONMENT AND IN RADIOMEDICINE <i>V. Tregubova, A. Safonov, K. German, V. Peretrukhin, F. Poineau</i>	84
THE STUDY OF CO-CRYSTALLIZATION OF URANIUM AND PLUTONIUM NITRATE HEXAHYDRATE IN THE PROCESS OF MIXTURE UNDIVIDED REFINING CRYSTALLIZATION <i>V.I. Volk, L.V. Arseenkov, S.A. Nikonov, S.N. Veselov</i>	85
STUDY ON SEPARATION OF AMERICIUM AND EUROPIUM BY INORGANIC EXCHANGER ZIRCONIUM PHOSPHATE <i>E.W. Wiikinkoski, R. Harjula</i>	86
MANAGEMENT OF HIGH LEVEL WASTE DERIVED IN THE CLOSED NUCLEAR FUEL CYCLE <i>S.V. Yudintsev</i>	87
RECOVERY OF ACTINIDES AND LANTHANIDES BY NOVEL SOLID-PHASE EXTRACTANTS FROM NITRIC ACID SOLUTIONS <i>E.A. Zakharchenko, N.P. Molochnikova, O.B. Mokhodoeva, G.V. Myasoedova</i>	88
SOPRTION OF CESIUM RADONUCLIDES BY FERROCYANIDE SORBENTS BASED ON CARBON FIBERS <i>V.V. Zheleznov, I.V. Sheveleva, V.G. Kuryavyi</i>	89
3. NUCLEAR MEDICINE	91
RADIATION ENGINEERED POLYMER NANOCARRIERS FOR A NEW GENERATION OF NANOPARTICLE BASED TUMOR SPECIFIC RADIOPHARMACEUTICALS <i>C. Dispenza, M.A. Sabatino, L. Ditta, N. Grimaldi, M. Mangione, G. Adamo, S. Rigogliuso, D. Bulone, G. Ghersi, M. Jonsson</i>	93

The First Russian-Nordic Symposium on Radiochemistry

YTTRIUM, LUTETIUM AND LANTHANUM BINDING BY NEW AZACROWN LIGAND IN AQUEOUS SOLUTIONS <i>B.V. Egorova, M.S. Oshchepkov, Yu.V. Fedorov, S.N. Kalmykov, O.A. Fedorova</i>	94
IMPROVED SYNTHESIS OF 6-[¹⁸ F]-L-THREO-DIHYDROXYPHENYLSERINE, A POTENTIAL PET RADIOTRACE FOR THE NOREPINEPHRINE SYSTEM <i>O.S. Fedorova, V.V. Orlovskaja, D.M. Troushin, V.I. Maleev, T.F. Savelieva, Yu.N. Belokon, C.W. Chang, R.S. Liu, R.N. Krasikova</i>	95
THE RADIOSYNTHESIS OF 6-[¹⁸ F]FDOPA USING [¹⁸ F]SELECTFLUOR <i>S. Forsback, A. Kirjavainen, I. Stenhagen, V. Gouverneur, O. Solin</i>	96
RADIOISOTOPE GENERATORS OF SHORT-LIVED ALPHA-EMITTING RADIONUCLIDES FOR NUCLEAR MEDICINE <i>L.I. Guseva</i>	97
ELECTROPHILIC AND NUCLEOPHILIC FLUORINATION OF [¹⁸ F]NS18334 <i>A.K. Kirjavainen, S. Forsback, P. Marjamäki, M. Haaparanta-Solin, D. Peters, O. Solin</i>	98
PET IN RUSSIAN FEDERATION: STATE OF THE ART, TRENDS AND FUTURE PERSPECTIVES <i>R.N. Krasikova</i>	99
RESEARCH OF THE POSSIBILITY OF TECNETIUM-99m OBTAINING USING MOLYBDENUM OXIDES SAMPLES IRRADIATED IN TRIGA MARK II LOW FLUX REACTOR <i>A.V. Matyskin, V.S. Skuridin</i>	100
PREPARATION AND RADIOCHEMICAL SEPARATION ¹⁸⁸ Re IN THE REACTOR IRT-T <i>V.G. Merkulov, E.V. Chibisov, V.V. Zukau, Yu.S. Maslennikov, D.V. Kabanov, A.O. Pavlyuk</i>	101
EFFECT OF PROTECTING GROUP ON THE RADIOCHEMICAL YIELD OF ¹⁸ F-FLUORINATED SUBSTITUTED BENZALDEHYDES <i>V.V. Orlovskaja, O.S. Fedorova, D.M. Troushin, V.I. Maleev, T.F. Savelieva, Yu.N. Belokon, R.N. Krasikova</i>	102
SEPARATION AND PRECONCENTRATION OF ACTINIDES AND RARE EARTH ELEMENTS BY EXTRACTION CHROMATOGRAPHY <i>V.S. Ostapenko, A.N. Vasiliev, E.V. Lapshina, S.V. Ermolaev, S.N. Kalmykov, R.A. Aliev</i>	103
STATUS OF THE RADIO ISOTOPE COMPLEX RIC-80 (RADIO ISOTOPES AT CYCLOTRON C-80) AT PNPI <i>V.N. Panteleev, A.E. Barzakh, L.Kh. Batist, D.V. Fedorov, A.M. Filatova, K.A. Mezilev, P.L. Molkanov, F.V. Moroz, S.Yu. Orlov, Yu.M. Volkov, E.K. Dyakov, I.B. Savvatimova, A.A. Yaskolko</i>	104
MODULAR NANOTRANSPORTERS FOR NUCLEAR DELIVERY OF ANTI-CANCER RADIONUCLIDES AND PHOTOSENSITIZERS <i>A.A. Rosenkranz, T.A. Slastnikova, M.R. Zalutsky, A.S. Sobolev</i>	105
¹⁸ F-FLUOROALKYLATED ANALOGUES OF ORM-13070 FOR PET IMAGING OF α_2C -ADRENOCEPTORS IN THE BRAIN <i>V. Stepanov, R.N. Krasikova, S.J. Finnema, J. Sallinen, P. Holm, O. Solin, C. Halldin</i>	106
SSC RF – IPPE RADIOISOTOPE PRODUCTION FOR NUCLEAR MEDICINE <i>D.V. Stepchenkov, N.A. Nerozin, E.V. Sulim, A.A. Semenova</i>	107
A POTENTIAL FOR PRODUCTION MEDICAL RADIONUCLIDES IN RUSSIA <i>B.L. Zhuikov</i>	108
SOLID PHASE RADIOFLUORINATION FOR DOSE-ON-DEMAND PET <i>F.A. Zhuravlev, B. Mathiessen</i>	109
EXPERIMENTAL INSTALLATION AT IRT-T OF TPU FOR IODINE-125 PREPARATION <i>V.V. Zukau, G.G. Glukhov, Yu.N. Adischev</i>	110

4. ENVIRONMENTAL RADIOACTIVITY AND RADIOECOLOGY	111
RADIOECOLOGICAL EXPERT EXAMINATION OF THE CHEMISTRY DEPARTMENT AND BOTANICAL GARDEN TERRITORIES OF M.V.LOMONOSOV MOSCOW STATE UNIVERSITY <i>A.A. Abramov, S.V. Volkova, A.V. Agaeva, S.Yu. Yegorov, G.A. Zaikin</i>	113
COMPARATIVE EVALUATION OF THE BIOAVAILABILITY OF URANIUM AND ARTIFICIAL RADIONUCLIDES IN THE ECOSYSTEM OF THE YENISEI RIVER BASIN <i>A. Bolsunovsky, M. Medvedeva</i>	114
RADIONUCLIDES IN THE KOLA PENINSULAS' GEOSYSTEMS <i>A.V. Evseev, A.D. Telelekova, N.B. Sedova</i>	115
RADIOACTIVE SAND ACCUMULATIONS ON THE BEACHES OF THE WHITE SEA, THE BLACK SEA AND THE SEA OF AZOV <i>V.M. Fedoseev, G.A. Safyanov, V.S. Voloshin, I.N. Beckman, Yu.A.Sapozhnikov, N.V. Shevchenko, L.M. Shipilova, Y.I. Lys, D.A. Minyaeva, G.B. Ryazantsev</i>	116
RED-OX STATES OF URANIUM IN MINERALS BASED ON CHEMICAL SHIFTS OF X-RAY LINES <i>R. Gieré, E.V. Puchkova, R.V. Bogdanov</i>	117
BEHAVIOR OF RADIONUCLIDES IN NATURAL ENVIRONMENT OBJECTS IN THE IMPACT ZONE OF KRATON-3 UNDERGROUND NUCLEAR EXPLOSION IN THE REPUBLIC OF SAKHA <i>T.A. Goryachenkova, I.E. Kazinskaya, E.A. Kuzovkina, V.S. Ryuleeva, A.P. Novikov</i>	118
Am(III) SORPTION ONTO TiO ₂ AND NdPO ₄ <i>N.N. Gracheva, A.Yu. Romanchuk, E.A. Smirnov, A.V. Garshev, E.A. Shirshin, K.I. Bryukhanova, K.S. Gavrichev, S.N. Kalmykov</i>	119
ENVIRONMENTAL IMPACTS OF FUKUSHIMA DAIICHI ACCIDENT IN FINLAND – CHALLENGES OF STUK <i>T.K. Ikäheimonen, P. Vesterbacka, A. Mattila, A.-P. Leppänen</i>	120
BEHAVIOUR OF SELENIUM IN GRANITIC ROCK <i>J. Ikonen, P. Sardini, M. Voutilainen, K. Hänninen, L. Jokelainen, R. Pehrman, A. Martin, M. Siitari-Kauppi</i>	121
RADIOECOLOGICAL CHARACTERISTICS OF ChNPP EXCLUSION ZONE AT THE LATE PHASE OF THE ACCIDENT <i>Yu.A. Ivanov</i>	122
URANIUM (VI) SORPTION ONTO ROCK SAMPLES FROM AREAS “KAMENNY” AND “ITATSKY” (NIZHNEKANSKY MASSIVE) <i>N.V. Kuzmenkova, V.G. Petrov, I.E. Vlasova, V.A. Petrov, V.V. Poluektov, S.N. Kalmykov</i>	123
ANALYSIS OF THE RADIOACTIVE SAMPLES FROM RESERVOIR V-17 (OLD SWAMP) <i>N.V. Kuzmenkova, I.E.Vlasova, Yu.A. Sapozhnikov, E.A. Pryakhin, W. de Paolo, I.A. Ivanov, S.N. Kalmykov</i>	124
SPECIATION OF NEPTUNIUM IN SOILS AND ITS ACCUMULATION BY BIOTA <i>E.A. Lavrinovich, A.V. Abramova, A.P. Novikov</i>	125
ISOTOPE EXCHANGE OF ⁴⁵ Ca AND ¹⁴ C ON CALCITE <i>J. Lempinen, S. Kallio, M. Hakanen, J. Lehto</i>	126
SORPTION OF CESIUM ON PEAT <i>M. Lusa, S. Virtanen, J. Lempinen, A.T.K. Ikonen, A.-M. Lahdenperä, J. Lehto</i>	127
COMPARISON OF SORPTION CHARACTERISTICS OF CRUSHED AND MONOLITHIC ROCKS <i>K.V. Martynov, L.I. Konstantinova, Yu.V. Konevnik, E.V. Zakharova</i>	128

The First Russian-Nordic Symposium on Radiochemistry

EFFECT OF ORGANOMINERAL SORBENTS APPLICATION ON BEHAVIOR OF ^{90}Sr IN SOIL – PLANT SYSTEM <i>L.N. Maskalchuk, A.A. Baklay, T.G. Leontieva</i>	129
RADIOECOLOGICAL CONDITION OF TAILINGS DAMS OF THE MOUNTAIN PROCESSING ENTERPRISES OF APATITY-KIROVSKY DISTRICT OF MURMANSK REGION <i>N.A. Melnik</i>	130
COMPARATIVE STUDY ^{137}Cs AND ^{90}Sr SORPTION BY REED PEAT AT CHANGE OF WATER COMPOSITION <i>T.B. Menshikh</i>	131
SIZE DISTRIBUTION AND CONCENTRATIONS OF RADIOACTIVE AEROSOLS NEAR THE CHERNOBYL NPP: 1986-2013 <i>B.I. Ogorodnikov, A.K. Budyka</i>	132
URANIUM RECOVERY FROM NATURAL WATER BODIES <i>Yu.V. Ostrovsky, G.M. Zabortsev, D.Yu. Ostrovsky, V.P. Isupov</i>	133
Cs-137 IN SEDIMENTS AND BENTHIC FAUNA IN THE EASTERN PART OF GULF OF FINLAND <i>I. Outola, K. Vaaramaa, H. Kankaanpää</i>	134
DISTRIBUTION OF RADON GROUND FLUX IN MOSCOW <i>T.B. Petrova, P.S. Miklyaev</i>	135
DISTRIBUTION OF RADIONUCLIDES IN THE ABIOTIC AND BIOTIC COMPONENTS OF THE ECOSYSTEM OF RESERVOIR R-17 "MAYAK" <i>E.A. Pryakhin, G.A. Tryapitsyna, S.S. Andreev, D.I. Osipov, N.I. Atamanyuk, A.V. Konovalov, I.A. Ivanov</i>	136
POLONIUM-210 IN MEDICINAL PLANTS <i>E.V. Puchkova, O.G. Bogdanova, A.M. Zarubo</i>	137
DISTRIBUTION OF ^{137}Cs IN REINDEER MEAT: COMPARISON OF SITUATIONS WITH HIGH AND LOW ACTIVITY CONCENTRATIONS <i>T.M. Rasilainen, K. Rissanen</i>	138
COLLIDERS AND THEIR POSSIBLE GEORADIOCHEMICAL EFFECTS ON THE ENVIRONMENT <i>G.B. Ryazantsev, I.N. Beckman, D.A. Minyaeva</i>	139
CHALLENGES ASSOCIATED WITH RADIOACTIVE PARTICLES IN THE ENVIRONMENT <i>B. Salbu, O.Ch. Lind</i>	140
THE OB' RIVER BASIN AS A SOURCE OF GLOBAL FALLOUT ^{137}Cs CONTAMINATION OF THE ARCTIC OCEAN <i>I.N. Semenkov, A.Yu. Miroshnikov</i>	141
AEROSOL PARTICLES FROM CHERNOBYL LAVAS <i>A.A. Shiryayev, I.E. Vlasova, B.I. Ogorodnikov, N.N. Dogadkin</i>	142
RADIONUCLIDE AND METAL CONTAMINATION IN PIT LAKES IN FORMER U SITES IN CENTRAL ASIA <i>L. Skipperud, B.O. Rosseland, P. Stegnar, M. Yunusov, L.M. Burkitbaev, L.S. Heier, B. Salbu</i>	143
CEEPRA - COLLABORATION NETWORK ON EUROARCTIC ENVIRONMENTAL RADIATION PROTECTION AND RESEARCH <i>D. Solatie, A.-P. Leppänen</i>	144
CONTENTS RADIONUCLIDES IN WATER OF RIVER SYSTEM TECHA-ISET-TOBOL-IRTYSH-OB <i>A.V. Trapeznikov, V.N. Trapeznikova, S.S. Andreev, A.V. Korzhavin, E.A. Pryakhin</i>	145
THE BEHAVIOR OF TECHNETIUM IN SEDIMENTS OF LAKES DIFFERENT TYPES <i>V. Tregubova, A. Safonov, K. German, V. Peretrukhin</i>	146

The First Russian-Nordic Symposium on Radiochemistry

RE-DISTRIBUTION OF RADIONUCLIDES AND SECONDARY MINERAL FORMATION IN THE TALVIVAARA MINING PROCESS <i>H. Tuovinen, E. Pohjolainen, D. Vesterbacka, C. Kirk, D. Read, D. Solatie, J. Lehto</i>	147
STATISTICAL ANALYSIS METHODS APPLICATION FOR THE DETERMINATION OF THE RADIONUCLIDE MIGRATION IN THE NEAR-SURFACE STORAGE FACILITIES <i>E. Veselova, A. Rybakov</i>	148
MICRODISTRIBUTION OF ALPHA- AND BETA-EMITTING NUCLIDES IN THE SEDIMENTS OF THE INDUSTRIAL RESERVOIR V-17 (MAYAK PA) USING IMAGING PLATES <i>I.E. Vlasova, N.V. Kuzmenkova, A.A. Shiryaev, E.A. Pryakhin, S.N. Kalmykov, I.A. Ivanov</i>	149
THE APPROACHES TO REMEDIATION OF RADIOACTIVELY CONTAMINATED LANDS <i>A.V. Voronina, V.S. Semenishchev, M.O. Savchenko, T.V. Gorbunova</i>	150
DIFFUSION OF CESIUM IN GRIMSEL GRANODIORITE: SIMULATIONS IN TIME DOMAIN WITH HETEROGENEOUS SORPTION PROPERTIES <i>M. Voutilainen, P. Sardini, M. Siitari-Kauppi, A. Martin, J. Timonen</i>	151
RADIOECOLOGICAL ASSESSMENT OF TOMSK-SEVERSK NUCLEAR FACILITY TERRITORY ON THE BASED OF AEROSOLS IN SNOW STUDY <i>E.G. Yazikov, A.V. Talovskaya, E.A. Filimonenko</i>	152
¹²⁹ I RECORD IN THE TAAL LAKE SEDIMENT, PHILIPPINES: IMPLICATION FOR GLOBAL FALLOUT OF ¹²⁹ I IN LOW LATITUDE <i>L.Y. Zhang, X.L. Hou, W.J. Zhou, H.C. Li, N. Chen, Y.K. Fan, Q. Liu, Y.C. Fu</i>	153
5. RADIOANALYTICAL CHEMISTRY	155
STUDIES OF URANIUM RED-OX STATES BY THE METHOD OF CHEMICAL SHIFTS OF THE L _{α1} -L _{α2} EMISSION X-RAY LINES <i>R.V. Bogdanov, A.G. Krivitsky, E.V. Puchkova</i>	157
METHODS OF QUALITY CONTROL OF Sr-82 ACTIVE PHARMACEUTICAL INGREDIENT (API) <i>A.S. Bolonkin, A.V. Dunin, K.A. Murashin, N.A. Nerozin, N.P. Togaeva, S.V. Khamyanov, V.V. Shapovalov</i>	158
DETERMINATION OF URANIUM, THORIUM AND TRITIUM IN DRILLING FLUIDS WITH A HIGH CONTENT OF SALTS, OIL AND POLYMERS <i>L.G. Bondareva</i>	159
COLLOID-STABLE SELECTIVE SORBENTS FOR CESIUM AND STRONTIUM UPTAKE <i>S.Yu. Bratskaya, V.V. Zheleznov, D.V. Marinin, R. Koivula, R. Harjula, A. Musyanovych, A. Synytska, F. Simon, V.A. Avramenko</i>	160
THE INFLUENCE OF A SURFACE CHEMISTRY OF DETONATION NANODIAMONDS ON SORPTION PROPERTIES AGAINST CATIONS OF RADIONUCLIDES <i>Yu.P. Buchatskaya, A.Yu. Romanchuk, A.A. Shiryaev, I.I. Kulakova, E.A. Shirshin, S.N. Kalmykov</i>	161
URANYL SPECIATION USING TIME-RESOLVED LASER-INDUCED FLUORESCENCE SPECTROSCOPY: WHY EXCITATION INTENSITY AFFECTS FLUORESCENCE DECAY RATE? <i>G.S. Budylin, E.A. Shirshin, V.G. Petrov, V.V. Fadeev, S.N. Kalmykov</i>	162
RADIONUCLIDES FOR INVESTIGATIONS OF ION TRANSPORT IN MEMBRANES OF CHEMICAL SENSORS PREPARED BY PULSED LASER DEPOSITION <i>Yu.E. Ermolenko, D.S. Kaliagin, V.V. Kolodnikov, Yu.G. Vlasov</i>	163
APPLICATION OF ALPHA-SPECTROMETRIC ANALYTICAL METHOD FOR EVALUATION OF NATURAL WATERS ACTIVITY <i>G.G. Glukhov, E.S. Donyaeva, V.V. Zukau, Yu.V. Nesterova, I.V. Chikova</i>	164
SORPTION PROPERTIES OF NANOSTRUCTURED POTASSIUM ALUMINOSILICATE <i>P.S. Gordienko, S.B. Yarusova, I.A. Shabalin, V.V. Zheleznov, D.V. Marinin</i>	165

The First Russian-Nordic Symposium on Radiochemistry

MICROWAVE METHOD OF OPENING SOLID SAMPLES FOR CARRYING OUT RADIOCHEMICAL ANALYSIS <i>M.M. Hahunova</i>	166
RADIOCHEMICAL ANALYSIS OF RADIONUCLIDES: STATUS AND PROGRESS <i>X. Hou</i>	167
POSSIBILITIES OF TIME OF FLIGHT MASS SPECTROMETER WITH A PULSED GLOW DISCHARGE LUMAS-30 FOR THE DIRECT ANALYSIS URANIUM OXIDE <i>I.S. Ivanov, A.A. Ganeev, A.S. Andropov</i>	168
THE REMOTE SEARCH FOR GAMMA SOURCES AND DETERMINATION OF THEIR DOSE RATES AT THE DRY STORAGE UNIT 3A IN ANDREEVA BAY DURING ACTIVITIES FOR IMPROVEMENT TO THE RADIOLOGICAL ENVIRONMENT <i>K.E. Ivanov, A.P. Varnavin, A.V. Korolev, B.S. Stepenov, A.K. Sukhoruchkin, Yu.A. Teterin, A.Yu. Teterin, V.V. Kharitonov, V.A. Selishev, A.N. Fedoseenkov, A.N. Krasnoshekov, A.S. Kosnikov, D.A. Kostikov</i>	169
SELECTIVE INITIATION OF CHEMILUMINESCENCE BY LASER-INDUCED EXCITATION OF LANTHANIDE AND ACTINIDE IONS IN AQUEOUS SOLUTIONS <i>I.N. Izosimov, N.G. Firsin, N.G. Gorshkov, V.A. Mikhalev, S.N. Nekhoroshkov</i>	170
THE COBALT-57 RADIONUCLIDE AS AN EMISSION MÖSSBAUER SPECTROSCOPIC PROBE FOR STUDYING CATION-BINDING SITES IN SOPHISTICATED BIOMOLECULES <i>A.A. Kamnev, Yu.D. Perfiliev, L.A. Kulikov</i>	171
SOLVENT EXTRACTION AND EXTRACTION CHROMATOGRAPHY ISOLATION AND SEPARATION OF Am(III), Pu(IV,V), Np(V) AND Eu(III) WITH MACROCYCLIC COMPOUNDS <i>A.Sh. Madumarov, A.A. Abramov, A.N. Vasiliev, V. Kovalev, A.M. Vatsuro, P.G. Mingalev, O.V. Dubovaya, G.V. Lisichkin</i>	172
SOPRTION OF STRONTIUM RADIONUCLIDES FROM SEAWATER <i>D.V. Marinin, V.V. Zheleznov, I.V. Sheveleva, T.A. Sokolnitskaya, E.V. Kaplun, V.A. Avramenko</i>	173
SPECTROPHOTOMETRIC METHOD OF PRECISE DETERMINATION OF URANIUM, PLUTONIUM AND OTHER RADIONUCLIDES IN SOLUTIONS BY SERIAL EQUIPMENT <i>D.L. Mialochkin, T.D. Gogoleva</i>	174
TRITIUM LABELED COMPOUNDS IN NANODIAMONDS MODIFICATION <i>I.Yu. Myasnikov, M.G. Chernysheva, G.A. Badun</i>	175
AUTOMATED MULTI-SAMPLE ANALYSIS FOR SIMULTANEOUS DETERMINATION OF TECHNETIUM, NEPTUNIUM, PLUTONIUM AND URANIUM IN LARGE-SIZED SEAWATER <i>J. Qiao, K. Shi, X. Hou</i>	176
T-55 SORBENT FOR RADIOCHEMICAL ANALYSIS AND LIQUID RADIOACTIVE WASTES TREATMENT <i>V.S. Semenishchev, A.V. Voronina</i>	177
USE OF RADIONUCLIDE MICROSCOPIC DIAGNOSTICS FOR THE DETERMINATION OF THE TRANSLATIONAL MOBILITY OF ATOMS AND OF THE CRYSTAL DEFECTIVENESS <i>A.V. Severin</i>	178
APPLICATION OF CAPILLARY ELECTROPHORESIS WITH UV DETECTION FOR SEPARATION AND DETERMINATION OF ACTINIDES <i>B. Zubekhina, V.A. Babain, N.V. Komarova, M.Ya. Kamentsev</i>	179
AUTHOR INDEX	181

1. Fundamental Radiochemistry and Nuclear Chemistry

SYNTHESIS OF DIETHYLDITRITIUMSTANNANE

A.A. Alferova¹⁾, T.A. Kochina²⁾, E.N. Sinotova¹⁾, V.V. Avrorin¹⁾

¹⁾ - Saint Petersburg State University, 198504, Russia, St. Petersburg, Petrodvorets, 26 University Ave, radiochem@yandex.ru

²⁾ - Institute of Silicate Chemistry of Russian Academy of Sciences, 199034, Russia, Saint-Petersburg, Adm. Makarova emb., 2, t-kochina@mail.ru

The aim of this work was the elaboration of microsynthesis methods for diethylditritiumstannane as a source of diethylstannylium cations.

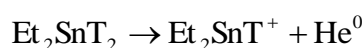

This synthesis was based on the reaction:



Lithium tritide was obtained by the interaction of n-butyl lithium with molecular tritium of 99.8% of isotope purity in the presence of tetramethylethyldiamine (TMEDA)

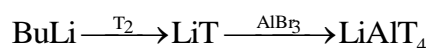

The reliable way of obtaining labeled compounds requests the elaboration of synthetic methods by carrying out multiple model syntheses in which tritium is replaced by protium (or deuterium) in the identical condition. The product synthesized in model experiments was identified by gas chromatography, NMR, and mass-spectrometry methods as Et₂SnH₂.

In the NMR ¹H (CDCl₃, 25°C) spectrum three groups of lines were observed, that are sextet, triplet and quintet with intensities which characterize compounds containing two methyl, two methylene groups, and two hydrogen atoms at Sn.

In the mass-spectrum (electron impact 18 and 70 eV) groups of lines were observed which correspond to the withdrawal of one hydrogen atom and ions with one and two ethyl groups detached. The scope of these facts confirms the structure of our synthesized compound as Et₂SnH₂. The product activity was measured by liquid scintillation counting at "Beta-2" radiometer. The yield of tritiated products was 10%. The multiplicity label was 1.8±0.2.

This work was supported by the RFFI grant № 12-03-00383. Authors acknowledge administration and employees of Khlopin Radium Institute for giving the opportunity to fulfill the synthesis of labeled compounds.

REFINEMENT OF THE ^{225}Ac HALF-LIFE

A.S. Bolonkin, A.V. Dunin

State Scientific Centre of the Russian Federation – Institute for Physics and Power Engineering named after A.I. Leypunsky; Bondarenko Sq., 1, Obninsk, Kaluga Region, 249033, Russia; e-mail: si@ippe.ru

^{225}Ac half-life period determination is connected with rather old measurements: in 1947 [1] ($T_{1/2} = 10$ days, measurement method is photoemulsion) and in 1950 [2] ($T_{1/2} = 10.0 \pm 0.1$ days, measurement method is pulse analyzer). Evaluated half-life period used in databases available has been directly taken from [2] (1950).

^{225}Ac isotope of high degree purification from long-lived impurities (for medical application) is obtained on the basis of $^{229}\text{Th}/^{225}\text{Ra}/^{225}\text{Ac}$ generator systems. Change of ^{225}Ac quantity is determined by β -spectrometry in samples with sealed layer according to the activity of β -emitting daughter decay products. Confirmatory measurements have been performed by γ -spectrometry according to total absorption peaks of ^{221}Fr (217.6keV) and ^{213}Bi (439.7keV) and integral impulse set as well.

71 groups of observations have been obtained (decay curves). Half-life period and assessment of standard deviation in every observation group have been calculated by method of linear regression analysis. Processing results prove the absence of nonlinearity accumulation in the course of decay. Mathematical check of obtained sample according to three criteria has not revealed any deviations of obtained distribution from Gaussian.

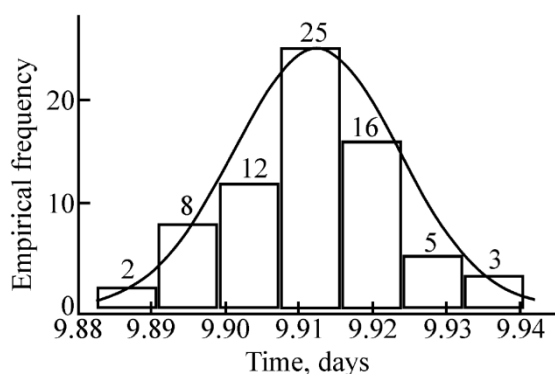

Fig. 1. ^{225}Ac half-life period value distribution histogram in seven equal intervals and normal distribution curve overlaid (“STADIA 8.0” statistical package is used).

The following value has been obtained for ^{225}Ac half-life period: $T_{1/2} = 9.912 \pm 0.003$ days. This value is within the limits of error of the existing evaluated value. γ -spectrometry has not revealed any systematic errors connected with the measurement method and sample processing.

[1] English A.C., Cranshaw T.E., Demers P., Harvey J.A., Hincks E.P., Jelley J.V., May A.N. The (4n+1) radioactive series. // Phys. Rev., 1947. Vol. 72, pp. 253–254.

[2] Hagemann F., Katzin L.I., Studier M.H., Seaborg G.T., Ghiorso A. The 4n+1 Radioactive Series: The Decay Products of U^{233} . // Phys. Rev., 1950. Vol. 79 (3), pp. 435–443.

THE PERTECHNETATE-ION PRECIPITATION IN NITRIC ACID SOLUTIONS WITH O-PHEN COMPLEX OF IRON (II) NITRATE

T.A. Boytsova, V.A. Babain, A.A. Murzin

«Khlopin Radium Institute», Saint-Petersburg, Russia, 28, 2nd Murinsky ave., 194021, tboytsova@khlopin.ru

There are different methods of Tc recovery in neutral and nitric solutions such as liquid extraction, electrochemical precipitation, etc.

Data on technetium precipitation with organic dyes and bipyridyl (bipy) and 1,10-phenanthroline (o-phen) complexes of iron (II) has been presented earlier [1]. O-phen complex of iron (II) nitrate (Ferroin nitrate) showed the best results among the studied compounds.

Ferroin nitrate precipitates about 80% of Tc in neutral solution and about 50% in 1 mol/L nitric acid solution on conditions that Ferroin/Tc mole ratio in solution equals ½. The Fe/Tc metals mole ratio in sediments is about 0.6.

The main purpose of the work was to precipitate the most possible amount of Tc in nitric solutions with Ferroine nitrate.

When Ferroine/Tc mole ratio in 1 mol/L nitric acid solution equals 1, 92% of Tc and 81% of Fe move into sediment. The Fe/Tc metals mole ratio in sediments has changed a little, except for the sediment in 0.5 mol/L nitric acid solution, where it equals 1. Probably, the cause of this ratio's change is the coprecipitation of nitrate-ion and pertechnetate- ion.

The influence of the temperature of the precipitant solution on the TcO_4^- precipitation has been studied. The precipitation has been carried out with hot Ferroine nitrate solution on conditions that Ferroine nitrate/Tc mole ratio in solutions has been changed from ½ to 1/0.7 and temperature increases up to 45-50 °C and 65-70 °C.

Table 1. Technetium yield in the sediment in 1 mole/L HNO_3 solution ($C_{Tc}=1$ g/L)

Precipitation conditions Ferroine nitrate/pertechnetate- ion mole ratio	Temperature of the precipitant, °C		
	20	45-50	65-70
	Technetium yield, %		
1/2	50±3	80±3	85±7
1/1	92±7	92±5	95±5
1/0.7	-	91±6	90±3

The use of hot Ferroine nitrate solution for the pertechnetate-ion precipitation allows to increase the Tc amount in the formed sediment on conditions that Ferroin/Tc mole ratio equals ½. Fe/Tc metals mole ratio in sediments changes also. The precipitation with hot ($T=45-70^{\circ}C$) complex solution gives 1 mole Fe per 0.81 mole Tc in the sediment. The precipitation with cold ($T=20^{\circ}C$) complex solution gives 1 mole Fe per 1.7 mole Tc.

In case of pertechnetate- ion recovery in uranyl nitrate solution uranium coprecipitation with the sediment of o-phen complex of iron (II) pertechnetate has been revealed.

[1] T.A. Boytsova, A.A. Murzin, B.A. Babain. Technetium precipitation in nitric acid solutions with organic cations and complexes of metals. «Radiochemistry-2012», p. 200.

**EXAMINATION OF THE RADIUM-LEAD START COMPOSITION
FOR ^{226}Ra IRRADIATION**

**P.S. Butkalyuk¹⁾, I.L. Butkalyuk¹⁾, I.E. Vlasova²⁾, S.V. Tomilin¹⁾,
R.A. Kuznetsov¹⁾**

¹⁾ – *JSC “SSC RIAR”, Russia, Dimitrovgrad, orip@niiar.ru*

²⁾ – *Radiochemistry Division, Chemistry Department, Lomonosov Moscow
State University, Moscow, ivlas@radio.chem.msu.ru*

One of the methods to accumulate medical-purpose short-lived alpha emitters is irradiation of radium in the high-flux nuclear reactor. Activation of radium with neutrons generates radionuclides ^{227}Ac , ^{228}Th and ^{229}Th . They can be used as parent isotopes to accumulate ^{227}Th , ^{223}Ra , ^{224}Ra , ^{212}Pb , ^{212}Bi , ^{225}Ac and ^{213}Bi .

When irradiating radium compact samples, significant losses occur resulting from the resonance self-shielding (up to 40 %). To reduce the self-shielding effect, we have earlier suggested dilution of radium compounds with a low-capture lead oxide. To produce the radium-lead composition, co-deposition of radium-lead carbonates was performed followed by the precipitate calcination to convert lead carbonate to lead oxide (II).

The examination revealed that during the calcination of both radium and lead carbonates at 800°C, radium plumbate RaPbO_3 with the cubic perovskite structure is generated in the air. The objective is to examine the effect of radium plumbate on the radium distribution uniformity in the start composition.

The examination was performed using barium compounds simulating radium. The model carbonate mixtures were produced by co-deposition of barium and lead carbonates using acidified solution containing $\text{Ba}(\text{NO}_3)_2$ and $\text{Pb}(\text{NO}_3)_2$ in the ratio of 1:2 for 0.25 M K_2CO_3 . The precipitates were multiply washed with distilled water, separated by filtration and examined using the thermogravimetric and differential thermal analyses. The analysis of obtained data resulted in selecting three temperatures for a detailed examination: $T=500^\circ\text{C}$, $T=600^\circ\text{C}$, $T=800^\circ\text{C}$. Based on the X-ray phase analysis, barium is presented in the parent preparation mainly as mixed carbonate $(\text{Ba,Pb})\text{CO}_3$ with the traces of BaCO_3 mere phase. The preparations calcinated at 800°C contains barium as plumbate BaPbO_3 with the cubic perovskite structure. At lower temperatures the samples are mixtures of BaCO_3/PbO with possible lead oxides of a higher oxidation level.

To examine the barium distribution uniformity, samples of mole ratio $\text{Ba:Pb} \approx 1:15$ were produced. The examination of the samples was done using scanning electron microscopy (SEM). The analysis of the parent carbonate mixture has shown relatively uniform distribution of barium and lead in the sample. The calcination at 500°C and 600°C does not change qualitatively the distribution of the components. In the samples generated at 800°C, the component distribution is not uniform as there are regions highly enriched in barium of relatively medium content as well as regions with no barium. The latter are most likely to be pure lead oxide (II). Similar examinations were done for mixed nitrates $(\text{Ba,Pb})(\text{NO}_3)_2$. According to the differential thermal and X-ray phase analyses data, barium plumbate BaPbO_3 is generated at the temperature higher 700°C. The excess of lead exists in the form of oxide. The SEM results also show the significant non-uniformity of the sample composition.

RADIOGRAPHIC EXAMINATION OF CURIUM ALLOYS WITH COBALT, IRON AND CARBON

T.A. Chernakova, V.M. Radchenko

Joint Stock Company “State Scientific Center – Research Institute of Atomic Reactors”, Dimitrovgrad, orip@niar.ru

Over many years JSC “SSC RIAR” has been performing activities on the production and investigation of metals of transplutonium elements (TPE), their alloys and compounds.

This paper presents the results of production and radiographic examination of micro-samples of curium-244 compounds with iron, cobalt and carbon, namely an identification of crystal lattices of the compounds obtained and calculation of crystal lattice parameters, study on the effect of intensive alpha-decay on crystal structures of intermetallides and carbides.

Samples of the Cm-Co, Cm-Fe and Cm-C systems were prepared by high temperature condensation of metal curium vapor onto corresponding substrates. In the Cm-C sample such a “substrate” represents a thin amorphous carbon layer applied preliminary onto a flat iridium plate. The radiographic examination results of the produced compounds are presented in the table below.

Table. Crystal lattice parameters of phases detected during investigation of the Cm-Fe, Cm-Co and Cm-C systems

System	Phase	Lattice	Lattice parameters		
			<i>a</i> , Å	<i>c</i> , Å	<i>V</i> , Å ³
Cm-Co	Co ₁₇ Cm ₂	Hexagonal (<i>P6₃/mcm</i>)	8.378(7)	8.070(5)	491(1)
	Co ₅ Cm	Hexagonal (<i>P6/mmm</i>)	4.88(1)	4.08(4)	84(1)
	Co ₂ Cm	Cubic (<i>Fd3m</i>)	7.242(2)	-	-
Cm-Fe	Fe ₁₇ Cm ₂	Hexagonal (<i>P6₃/mmc</i>)	8.406(3)	8.122(2)	497.0(5)
	Fe ₂ Cm	Cubic (<i>Fd3m</i>)	7.213(2)	-	-
Cm-C	Cm ₂ C ₃	Cubic (<i>I43d</i>)	8.3904(5)	-	-
	Cm ₃ C	FCC	5.172(2)	-	-

Note. In the column “Lattice” a lattice spatial group is indicated in brackets. *V* – is volume of a crystal lattice elementary cell. Definition errors of the last character are given in brackets after the lattice parameter values.

In the Cm-Co system three intermetallic compounds were detected: Co₁₇Cm₂ (hexagonal lattice of spatial group *P6₃/mcm*), Co₅Cm (hexagonal lattice of spatial group *P6/mmm*) and intermetallide Co₂Cm (cubic lattice of spatial group *Fd3m*). Cadmium did not show any solubility in α - and β -Co at room and elevated temperature. In the Cm-Fe system two intermetallic compounds were detected: Fe₁₇Cm₂ (hexagonal lattice of spatial group *P6₃/mcm*) and Fe₂Cm (cubic lattice of spatial group *Fd3m*). This system did not show mutual solubility of its components at room temperature. The effect of high alpha-activity of ²⁴⁴Cm nuclide on the crystal structure of intermetallide Fe₂Cm was demonstrated. In the Cm-C system carbides Cm₂C₃ and Cm₃C with a cubic lattice were detected, which were isostructural with regard to carbides Am₂C₃ and Sm₃C. Crystal lattice parameters of the curium carbides were calculated and data on their x-ray amorphization induced by intensive ²⁴⁴Cm decay were obtained.

SCINTILLATION PHASE APPLICATION IN PHYSICAL CHEMICAL STUDIES: ADVANTAGES AND LIMITATIONS

M.G. Chernysheva, G.A. Badun

Dpt. Chemistry, Lomonosov Moscow State University, Moscow, Russia 119991

E-mail: maria_radiochem@hotmail.com

Liquid scintillation spectrometry of tritium in the application of scintillation phase technique is a good instrument to follow the distribution of labeled compound in the bulk of the system of two immiscible liquids one of each is a scintillator, and its concentration in the liquid/liquid subsurface layer. β -emitters of low energy are appropriate for such use. ^{14}C , ^{35}S or tritium are the most frequently used when it comes to bioorganic compounds. The technique involves introduction of radiolabeled compound in the system of two immiscible liquids one of each possess scintillation properties. The counting rate of such system is results from the amount of radioactive compound (I_V) in the bulk of the system and its excess in the subsurface layer (I_S), which thickness is determined by the path-length of particles.

$$I_V = \varepsilon a_{sp} c_{org} V \quad (1)$$

$$I_S = \varepsilon a_{sp} (0.5\Gamma + 0.27c_w h) S \quad (2)$$

Here, c_{org} and c_w are concentrations of the labeled compound in the organic and aqueous phases, respectively; Γ is the superficial excess of the compound; S is the area of the interface; ε is the registration efficiency of radiation in the organic phase, V is the volume of the organic phase; and a_{sp} is the specific radioactivity of the labeled compound and h is the zone thickness of the aqueous phase, by which the registration of radiation is possible. Thus, in cases of ^{14}C and ^{35}S the registration zone h is close to 30 μm , while in the case of tritium it doesn't exceed 1.6 μm .

With the help of tritium labeled compounds and scintillation phase approach the colloidal behavior of different types of surfactants (ionic, nonionic and zwitterionic), natural and synthetic polymers in water/organic liquids systems was studied. Application of organic liquids with the addition of naphthalene and 2,5-diphenyloxazole in amounts that don't influence the behavior of tested compounds, allowed to extend the organic phases using.

The technique of scintillation phase enables to follow the system for a long time without integrity destroying. Scintillation phase method has significant advantages when compounds mixtures are under the test. If only one component of the mixture is tritium labeled its behavior can be investigated on a background of the other components. Since the number of experiments is equal to the number of components of the mixture, laboriousness is the main complication of such studies.

However, for clear comparison of the results obtained using scintillation phase technique and one obtained by other methods several important circumstances must be taken into account that are discussed in a report.

SUPERHEAVY ELEMENTS IN THE PERIODIC TABLE: A BIRD'S EYE VIEW THROUGH "CHEMICAL GRAPHS"

Yu.A. Demidov¹⁾, A.V. Zaitsevskii^{1,2)}

¹⁾ – *FSBI “Petersburg Nuclear Physics Institute”, Gatchina, Leningrad district 188300, Russia, e-mail: iurii.demidov@gmail.com*

²⁾ – *NRC “Kurchatov Institute”, Kurchatova sq. 1, Moscow, 123182 Russia*

In recent years, several experiments on “chemical” identification of superheavy elements with atomic numbers $Z \geq 112$ have been successfully performed. All these experiments are based on the interaction of these element with noble metal surfaces and cannot provide a general picture of their basic chemical properties. Such picture, however, is necessary both for understanding the peculiar manifestations in the bottom part of the periodic table and for developing new experimental methods for “chemical” identification of the new elements. Here we report the attempt to obtain the required information from first-principle-based relativistic calculations of molecular electronic structure for simplest binary compounds of superheavy elements with the most common light elements, H, C, O, F, and Na. These calculations were performed within the two-component shape-consistent small-core pseudopotential model and employed the non-collinear version of relativistic density functional theory to treat electronic correlations. We focus on the properties of two superheavy elements, element 120 (E120) and copernicium (Cn, E112) which are expected to display particularly strong relativistic contraction and stabilization of the filled s-subshells. Chemical properties of E120 are less well known than the properties of Cn. There exist theoretical predictions of chemical properties of only several specific molecules and estimates of adsorption energies on some inert surfaces. The chemical properties of E112 have been theoretically studied in some detail, still insufficient to obtain a common understanding of the chemistry of this element. Significant difference between Cn and Hg chemistry is also confirmed experimentally. The comparison of the calculated equilibrium structures and energetics with the similar data for the compounds of the homologues of Cn and E120 visualized through the “chemical graphs” provides an insight into the trends of gas-phase chemistry of the heavy elements belonging to groups 2 and 12, respectively, and of the specificity of the superheavy elements. It is shown that all examined compounds of E120 should have weaker and longer chemical bonds than similar compounds of the second group elements from Sr to Ra. It can be therefore assumed that E120 is generally chemically more inert than its closest homologues. The regularity and smoothness of the characteristics behavior suggests that the formal position of E120 at the end of the second group is consistent with its chemical properties. The changes in chemical properties in passing from Hg to Cn are far from being so regular and uniform, presumably due to the interplay of the s-subshell contraction and destabilization of the $d_{5/2}$ subshell.

The work is partially supported by the RFBR (grants # 13-03-12252-ofi_m-2013 and # 13-03-01307) and SPbU Fundamental Science Research grant from Federal budget # 0.38.652.2013. Thanks are due to Prof. C. van Wüllen for supplying us with his relativistic DFT code. The calculations were performed at MCC NRC “Kurchatov Institute” (<http://computing.kiae.ru/>).

ROLE OF TEMPERATURE AND HYDROGEN CONTENT IN $[^{11}\text{C}]\text{CH}_4$ PRODUCTION

S. Helin¹⁾, E. Arponen¹⁾, J. Rajander²⁾, J. Aromaa²⁾, O. Solin^{1,2)}

*Turku PET Centre, <sup>1)University of Turku and ^{2)Åbo Akademi University,}
Kiinamylynkatu 4-8, 20520 Turku, Finland semi.helin@utu.fi</sup>*

Introduction. The $[^{11}\text{C}]\text{CH}_4$ yields are even at best far from theoretical amounts, as calculated from the well known nuclear cross section for the $^{14}\text{N}(p, \alpha)^{11}\text{C}$ nuclear reaction¹. A systematic investigation on $\text{N}_2\text{-H}_2$ target performance is presented in terms of saturation yields (Y_{sat} [GBq/ μA]) as a function of target body temperature, hydrogen content and irradiation current.

Materials and methods. Two Al-bodied target chambers (**T1** and **T2**) were used for $[^{11}\text{C}]\text{CH}_4$ production with $\text{N}_2\text{-H}_2$ gas targets. Grid supported inlet foil had a transparency of $\sim 76\%$. Volumes and loading pressures at $20\text{ }^\circ\text{C}$: (**T1**) 16.9 cm^3 and 35 bar, (**T2**) 25.6 cm^3 and 41 bar. Fixed 20 min 17 MeV proton beam irradiations were carried out in duplicate. Varied parameters were a) the target body temperature (10, 40, $70\text{ }^\circ\text{C}$), b) the irradiation current (10, 20, 30, $40\text{ }\mu\text{A}$) and c) total hydrogen content (volumes for **T1** and **T2**, and gas compositions 5 and 10 % H_2). The irradiation product was measured as reported elsewhere².

Results.

- An irradiation current intensity effect: $[^{11}\text{C}]\text{CH}_4$ saturation yield decreases when irradiation current increases.
- $[^{11}\text{C}]\text{CH}_4$ saturation yield increases by
 - elevating the target chamber body temperature and
 - increasing hydrogen partial pressure and total content
- Figure 3, $[^{11}\text{C}]\text{CH}_4$ saturation yield can be maintained at $\sim 5\text{ GBq}/\mu\text{A}$ level throughout the investigated current range by heating the target chamber body.

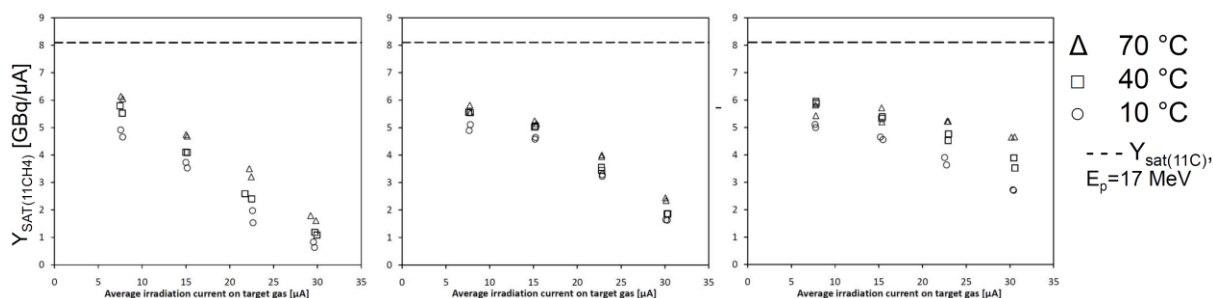

Fig. 1. T1 and 5 % H_2 .

Fig. 2. T2 and 5 % H_2 .

Fig. 3. T2 and 10 % H_2 .

Acknowledgement. The study was conducted within the "Finnish Centre of Excellence in Molecular Imaging in Cardiovascular and Metabolic Research" supported by the Academy of Finland, University of Turku, Turku University Hospital and Åbo Akademi University.

References

[1] <http://www-nds.iaea.org/medical/n4p11c6.html>

[2] S. Helin, E. Arponen, J. Rajander, J. Aromaa, O. Solin, The 13th International Workshop on Targetry and Target Chemistry Proceedings, Edited by Haroun S, Givskov A, Jensen M.. Risø-R-1787(EN) June 2011, pp.140-141.

CHEMILUMINESCENT SOLID-PHASE REACTIONS OF URANIUM(IV,VI) HYDROPHOSPHATES WITH XENON DIFLUORIDE

A. Itullina, G. Masyagutova, A. Mamykin

*IOChem USC RAS, Prospect Octyabrya, 71, Ufa, Russian Federation,
mamykin@anrb.ru*

We have studied chemiluminescence (CL) produced at the oxidation of uranium(IV) hydrophosphate $U(HPO_4)_2 \cdot 4H_2O$ by xenon difluoride XeF_2 in solid phase. The reaction proceeds spontaneously with a strong exothermal effect. An excited uranyl ion is the luminescence emitter. The luminescence intensity and CL yield is many times higher than the ones for the previously discovered CL in the oxidation reaction of uranium(IV) sulfate and hydroxide by xenon difluoride or sodium perxenate. [1, 2]. It is found that CL yield increase in the reaction is caused by a high yield of uranyl hydrophosphate emission and its high yield of excitation in the reaction. The latter may be related with the participation of a ligand – hydrophosphate anion – in the oxidative-reductive reaction.

We have detected bright visible with unaided eye CL in the process of solid phase reaction of uranyl hydrophosphate with xenon difluoride. The reaction has a specifically high brightness of luminescence (higher than in the uranium (IV) hydrophosphate) despite the fact that uranyl does not change its oxidative state in the course of the reaction (VI).

The emission observable in the visible and near-infrared regions of the specter refers to three emitters – the reaction products – uranyl (540 nm), atomic xenon (465 nm), singlet oxygen (633, 1270 nm). During the reaction the emission intensity is redistributed: a predominant blue component at the beginning changes for a green one. Red and infrared radiation could be observed in the course of all the reaction and it persisted for a long time after its completion (in a sealed cell).

It is assumed that the mechanism of these reactions presumes the formation of xenon-fluoride cation ($Xe_2F_3^+$) from difluoride xenon as a result of a high affinity of uranium (IV) and uranyl to fluoride ion. According to literature quantum chemical calculations electron affinity is $EA_{XeF^+}=10$ eV which is sufficient for the initiation of several redox reactions, for example, of uranium oxidation to uranyl (with quantum radiation 540 nm), oxidation of hydrogen in the uranyl group to singlet oxygen (633 and 1270 nm), oxidation of crystallization water. Experimental data and thermochemical calculations are presented in the support of the mechanism suggested.

This work has been conducted with the support of the Department of Chemistry of RASc program “Theoretical and experimental study of the nature of chemical bond and mechanisms of most important chemical reactions and processes”.

[1] Khazimullina L.N., Antipin V.A., Mamykin A.V., Tananaev I.G., Kazakov V.P., Myasoedov B.F., *Mendeleev Commun.*, 2005, **4**, 138.

[2] Khazimullina L.N., Antipin V.A., Mamykin A.V., Tananaev I.G., Kazakov V.P., Myasoedov B.F., *Radiochemistry*, 2007, **49**, 38.

CHEMILUMINESCENT REACTIONS OF TERBIUM(III) AND EUROPIUM(III) SULFATES WITH XENON DIFLUORIDE

A. Itullina, G. Masyagutova, A. Mamykin

*IOChem USC RAS, Prospect Octyabrya, 71, Ufa, Russian Federation,
mamykin@anrb.ru*

We have discovered chemiluminescence (CL) produced upon solid phase interaction of anhydrous $Tb_2(SO_4)_3$ powders with XeF_2 at room temperature.

The following three chemiluminescence emitters have been identified: the first one is related to atomic xenon luminescence (480 nm), the second one – to Xe^+ intermediate (540 nm), the third one - to the excited Tb(III) luminescence (545 nm and 590 nm). Luminescence of the first two emitters can be observed at the beginning of the reaction (about 5 minutes) and it lasts as long as XeF_2 is present in the reaction mixture. Tb(IV) formation has been registered in diffusion reflection specters in this interval.

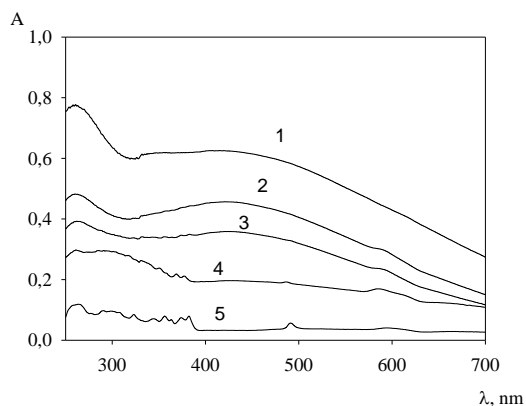

Fig. 1. Specters of diffusion reflection of $Tb_2(SO_4)_3$ and XeF_2 mixtures after 5 min (1), 15 min (2), 40 min (3) and after a day upon mixing (4). The specter of anhydrous $Tb_2(SO_4)_3$ before mixing is shown for comparison.

After XeF_2 has been used up, luminescence agrees with luminescence of excited $Tb^*(III)$ which generates upon subsequent reduction of Tb(IV) (in the interval of several hours). It is notable that the interaction of water solutions of $Tb_2(SO_4)_3$ и XeF_2 is not accompanied by chemiluminescence. These findings are in good correspondence with a well known fact that quantum efficiency increases in solid phases. The mixing of $Eu_2(SO_4)_3$ and XeF_2 powders also leads to notable chemiluminescence. In contrast with the above reaction, this one proceeds slowly. Over the course of the reaction luminescence can be observed with maximal wave lengths 480, 540, 615 nm. The emitter CL 615 nm refers to excited Eu(III). In the specters of diffusion reflection there appears a short-term absorption band with maximum 350 nm, which can refer to Eu(IV) intermediate absorption.

A possible mechanism of these reactions includes the formation of xenon-fluorination XeF^+ ($Xe_2F_3^+$) as a result of accepting by fluoride ion lanthanides. According to quantum-chemical calculations (literature data) electron affinity for this cation is $EA_{XeF^+}=10$ eV, which is sufficient for oxidation of Tb(III) and Eu(III) to the oxidation degree (IV).

This work has been conducted with the support of the Department of Chemistry of RASc program “Theoretical and experimental study of the nature of chemical bond and mechanisms of most important chemical reactions and processes”.

**LYSOZYME – ZWITTERIONIC SURFACTANT ADSORPTION
AT THE AQUEOUS/OCTANE INTERFACE AS STUDIED
BY SCINTILLATION PHASE METHOD**

R.A. Ivanov, O.A. Soboleva, M.G. Chernysheva, G.A. Badun

*M.V.Lomonosov Moscow State University, Chemistry Department;
119991, Leninsky Gory, 1/3, Moscow, Russia
e-mail: ivanov_r_a@mail.ru*

Scintillation phase technique provides information about the content of substances in organic phase and in the vicinity of aqueous/organic interface. This method allows to determine adsorption and distribution of each component of multi-component mixtures in two-phase system. In this research a mixtures of well-known protein lysozyme (Lz) with zwitterionic surfactant cocoamidopropyl betaine (CAPB) were investigated. CAPB is used in a lot of cosmetic and pharmaceutical formulations and detergents. The purpose of this work was to study the interference of the Lz and CAPB during its adsorption at the liquid/liquid interface and distribution between aqueous and octane phases.

We studied mixtures of Lz and CAPB with fixed concentration of protein 0.7 and 7 μ M and varied surfactant concentrations from 1 μ M to 10 mM. Aqueous phase was phosphate buffer saline (pH 7.2, ionic strength 0.16), organic phase was n-octane with scintillating additives (naphthalene and 2,5-diphenyloxazole). The tritium label was introduced into Lz and CAPB by tritium thermal activation method [1]. Interfacial tensions at the aqueous/octane interface were measured by pendant drop method. Particle size distributions were analyzed with the help of zeta-particle analyzer Zetatrac (Microtrac, USA).

It was found that the addition of Lz does not affect the adsorption of CAPB. However, the distribution ratio of CAPB in the system with Lz is two times higher than for free CAPB. This indicates the formation of hydrophobic protein-surfactant complex via electrostatic interaction between the polar groups of Lz and CAPB molecules.

The distribution ratio of CAPB in all investigated systems was significantly increased at surfactant concentration above 50 μ M apparently because of the formation of reverse micelles in organic phase. The increase of the surfactant concentration has little effect on the adsorption of proteins. The molecules of lysozyme remain in the adsorption layer even at high abundance of CAPB in solution. The type of the isotherms of interfacial tension with two plateau-region indicates that there is an interaction between the molecules of lysozyme and CAPB. The first plateau corresponds to binding of Lz with CAPB in aqueous solution. The dynamic light scattering has been proved the formation of large aggregates (diameter of tens and hundreds of nanometers) in the aqueous solution at CAPB concentration above 50 μ M. Apparently these aggregates are complexes of surfactants with partially unfolding protein globule. The second plateau corresponds to the micellization of surfactant. Based on results obtained, we proposed the mechanism of adsorption and distribution of Lz-CAPB mixture in the water/octane system.

[1] G.A. Badun, M.G. Chernysheva, A.L. Ksenofontov. *Radiochimica Acta*. 2012, 100, 401-408.

MICROCALORIMETRIC TITRATION AS A PERSPECTIVE METHOD FOR LIQUID-LIQUID EXTRACTION STUDIES

**M.D. Karavan¹⁾, I.V. Smirnov¹⁾, V. Hubscher-Bruder²⁾, F. Arnaud-Neu²⁾,
V.I. Kalchenko³⁾**

¹⁾ - Khlopin Radium Institute, 2nd Murinskiy pr., 28, 194021, Saint-Petersburg, Russia, mkaravan@khlopin.ru

²⁾ - Université de Strasbourg, IPHC, 25, rue Becquerel 67087 Strasbourg, France – CNRS, UMR7178, 67037 Strasbourg, France

³⁾ - Institute of Organic Chemistry, National Academy of Sciences of Ukraine, Murmanska str., 5, 02660, Kyiv-94, Ukraine

Reprocessing of radioactive nuclear wastes remains one of the most crucial problems in industry today. Long-lived radionuclides, the most hazardous components should be recovered from the total waste mass. This can be done by mass-transfer processes such as liquid-liquid extraction using selective ligands. A series of calixarenes bearing functional phosphine oxide groups was regarded as possible extractants. The extraction ability of these compounds towards lanthanides and actinides from nitric acid solutions (0.1 – 6.0 mol/l of HNO₃) into organic diluents (*meta*-nitrobenzotrifluoride, dichloroethane) was examined and led to the determination of the distribution coefficients of target elements. The binding properties of these macrocyclic compounds were compared to those of related monomers. Log-log plot analysis allowed to establish the stoichiometry of forming solvates. But these information were sometimes not sufficient to predict satisfactorily the behavior of such bulky and complex ligands in engineering processes.

To gain more information about the behavior of the phosphorylated calixarenes towards *f*-elements, their complexation ability in homogeneous medium was also studied. The method of investigation used was the isothermal titration calorimetry (ITC). This method allowed the thermodynamic characterization of the complexation, including stability constants, complexation enthalpy and entropy contributions and stoichiometry of forming complexes [1]. ITC method can also be successfully extended to determine liquid-liquid extraction thermodynamic parameters [2].

The main purpose of the present study is to develop a microcalorimetric method to better understand the liquid-liquid extraction of radioactive elements using calixarene-based ligands.

[1] Karavan, M., Arnaud-Neu, F., Hubscher-Bruder, V., et al. "Novel phosphorylated calixarenes for the recognition of *f*-elements", 2010, *Journal of Inclusion Phenomena and Macrocyclic Chemistry*, 66 (1), pp. 113-123.

[2] Zalupski, P.R., Nash, K.L., "Two-phase calorimetry. I. Studies on the thermodynamics of lanthanide extraction by bis(2-ethylHexyl) phosphoric acid", 2008, *Solvent Extraction and Ion Exchange*, 26 (5), pp. 514-533.

NEW THIALIX[4]ARENES AS EXTRACTANTS FOR METAL CATIONS

**M.D. Karavan¹⁾, I.V. Smirnov¹⁾, S.G. Kharchenko²⁾, A.B. Drapailo²⁾,
V.I. Kalchenko²⁾, S.V. Shishkina³⁾, O.V. Shishkin^{3),4)}**

¹⁾ – *Khlopin Radium Institute, 2nd Murinskiy pr., 28, 194021, Saint-Petersburg, Russia, mkaravan@khlopin.ru*

²⁾ - *Institute of Organic Chemistry, National Academy of Sciences of Ukraine, Murmanska str., 5, 02660, Kyiv-94, Ukraine*

³⁾ - *State Scientific Institution “Institute of Single Crystals”, National Academy of Sciences of Ukraine, Lenin ave., 60, 61001, Kharkiv-01, Ukraine*

⁴⁾ - *Department of Inorganic Chemistry, V. N. Karazin Kharkiv National University, Svobody sq., 4, Kharkiv, 61122, Ukraine*

Calixarenes can be used as a molecular platform for metal cations selective complexants design. Obtained compounds with phosphine oxide binding groups are capable to form strong Host-Guest supramolecular complexes and to extract actinides, lanthanides, transitional or heavy metals, platinum group metals from nitric acid aqueous solutions.

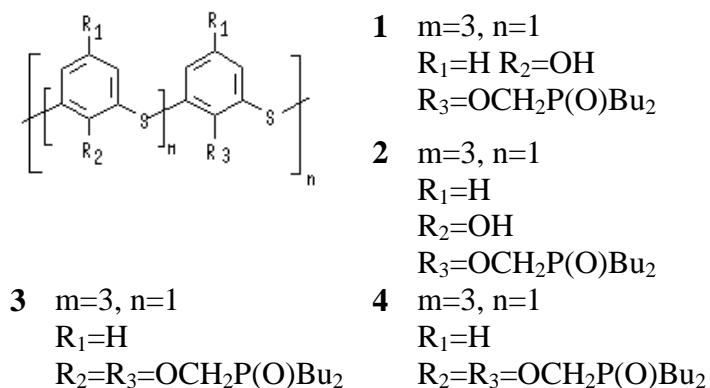

Fig. 1. Structural formula of studied thiacalix[4]arenes.

A series of thiacalix[4]arenes bearing one, two or four chelating dibutylphosphinoylmethoxy groups have been synthesized by the precise Williamson phosphoalkylation of thiacalixarene tetrols with tosylate of dibutylhydroxymethyl phosphine oxide in the presence of alkali metal carbonates or sodium hydride.

Extraction ability of four thiacalix[4]arenes towards americium, europium and technetium ions was examined.

Metals distribution ratios between *meta*-nitrotrifluoromethylbenzene (*m*-NBTF) and HNO₃ phases were determined.

Monophosphine monoxide does not extract Am, Eu and Tc under these conditions. Diphosphine dioxide possesses moderate extraction ability towards pertechnetate ion, while tetraphosphine tetraoxides extract it efficiently. *Cone*-shaped tetraphosphine tetraoxide efficiently extracts americium and europium due to cooperative (macrocyclic) effect to eight oxygen atoms of the phosphinoylmethoxy binding groups. Extraction ability of thiacalix[4]arene tetraphosphine tetraoxide is very similar to that of calix[5]arene pentaphosphine pentaoxide existing in the *cone* conformation.

**RATE OF THE EXTRACTION REE AT VIBRATION
ON A DYNAMIC INTERFACIAL LAYER**

N.F. Kizim, E.N. Golubina, A.M. Chekmarev

*Novomoskovsk Institute of Mendeleev University of Chemical Technology,
Russia, t. Novomoskovsk, st. Druzhba, 8. E-mail: nphk@mail.ru*

Extraction of rare-earth elements (REE) basically it is carried out by solutions di-(2-ethylhexyl)phosphoric acid (D2EHPA) or tributylphosphate (TBF). It is known, that at extraction of REE by solutions D2EHPA forms cruds, which block an interface and reducing the rate of extraction. In case TBF forms cruds slight and their influence on the rate of process is not high. The formation of cruds significantly for static systems. Therefore it is represented expedient to estimate possibility of increasing the rate of the extraction by mechanical influence on an interfacial layer.

In the given message the results of research of influence of mechanical vibrations for rate of the extraction of the some REE are presented.

The researched systems were water solutions ErCl_3 , PrCl_3 , $\text{Ho}(\text{NO}_3)_3$, $\text{Nd}(\text{NO}_3)_3$, $\text{Yb}(\text{NO}_3)_3$ / solution D2EHPA (or TBF) in a solvent. The range of concentration on a given taken element is made up $0,01 \div 0,1$ M and on extraction agent $0,01 \div 0,5$ M. As solvent used heptane, toluene and carbon tetrachloride. A range pH varied from 2,4 to 5,3.

The interface of liquid/liquid system with a distributed component is not motionless. Its elements execute oscillatory movement. If the system supply additional energy in the form of vibration of certain frequency there is a resonance which leads to increase the amplitude of vibrations. Preliminary researches had been defined resonant frequencies of vibration and their dependence on external factors is established.

For an estimation of influence of mechanical vibration on the extraction REE we will use acceleration factor of extraction (E), which were defined in the relation of concentration in organic phase for certain period of time with vibration effect on dynamic interfacial layer to the concentration in organic phase for the same time period but free of vibration.

If extragent is TBF with time the E decreases from 5 to 1.5, that is caused by decrease in intensity spontaneous surfacial convection (SSC), and at lower concentration of an extraction element and extragent the value E is high. Besides the maximum values E have been noted in systems with heptane. In case of use TBF we have not been notice distinction in values E at the extraction of REE yttrium and cerium subgroups.

If extragent is D2EHPA then it depends on the factor of acceleration of extraction from the time at which decreases (with 5 almost to 1), then leaves on a constancy and increases (approximately to 4).

The received dependences are caused by influence of mechanical vibrations on a number of processes developing in system, namely, on development SSC, formation of an interfacial layer, changes the hydrodynamic conditions in the interfacial area. Value E and a time range of areas depends by nature extraction element and a solvent, initial concentration extragent and an extraction element, and also pH.

COPRECIPITATION OF RADIONUCLIDE MICROQUANTITIES ON CHITOSANS OF DIFFERENT MOLECULAR MASSES IN SOLUTIONS

S.A. Kulyukhin¹⁾, I.E. Veleshko²⁾, A.N. Veleshko²⁾

- ¹⁾ - *Frumkin' Institute of Physical Chemistry and Electrochemistry, Russian Academy of Science, Leninskii prospekt, 31, 119071 Moscow, Russia, E-mail: kulyukhin@ipc.rssi.ru*
- ²⁾ - *Russian National Scientific Center "Kurchatov' Institute", Kurchatov sq., 1, Moscow, Russia*

The aim of this study was to study the behavior of radionuclides during coprecipitation on chitosans from solutions of complex chemical compositions. The possibility of ²³³U, ²³⁹Pu, ²⁴¹Am, ¹⁵²Eu, ⁹⁰Sr, ⁹⁰Y, and ⁶⁰Co coprecipitation on chitosans of different MM was studied.

At first, the solubility of the obtained chitosans in different media was studied. It was shown that high-molecular chitosan (HMC) with MM = 15·10⁵ g/mol and low-molecular chitosan (LMC) with molecular masses (MM) = 5·10³ g/mol were insoluble in distilled water and dissolved well at pH < 3. The solubility of chitosans in those solutions ranged from 8 g/l to 10 g/l and 10 g/l to 15 g/l for HMC and LMC, respectively. Increasing the solution pH to 6 for LMC and 8 for HMC resulted in the formation of a bulk thick precipitate. In both cases, the residual chitosan concentration was 0.45 g/l. In sea water at pH = 8.5, the solubility of HMC and LMC decreased to 0.045 g/l.

It was found that the efficiency of the sorption of the ²³³U, ²⁴¹Am, ¹⁵²Eu, and ⁶⁰Co radionuclides on crystallized HMC and LMC from salt solutions is low, with the distribution coefficients K_d being not higher than 100 ml/g after the time of contact between the solid and liquid phases of 1 h and at V/m = 100 ml/g. Since the studied chitosans displayed a low sorptive capacity, our further research was focused on the flocculation coprecipitation of radionuclides. As follow from the data on the ²³³U, ²³⁹Pu, ²⁴¹Am, ¹⁵²Eu, ⁹⁰Sr, ⁹⁰Y, and ⁶⁰Co coprecipitation on HMC and LMC in solution, in both cases degree of coprecipitation α of all radionuclides studied, except ⁶⁰Co and ⁹⁰Sr, reached virtually peak values at a chitosan concentration of 1 g/l. For HMC, α was 80% for ¹⁵²Eu and ⁹⁰Y, 99% for ²³³U and ²⁴¹Am, and 85% for ²³⁹Pu. In contrast to An, ¹⁵²Eu, and ⁹⁰Y, the α for ⁶⁰Co increased monotonically with increasing the HMC concentration in solution and at [HMC] = 5 g/l, reached 40%. For ⁹⁰Sr, α was not higher than 3% over the entire chitosan concentration range. For LMC α for An, ¹⁵²Eu, and ⁹⁰Y varied insignificantly ranging from 92% to 99%. For ⁶⁰Co and ⁹⁰Sr, α increased to 40% in the chitosan concentration range 0-1 g/l. Increasing the [LMC] in solution further on had hardly any impact on α for ⁹⁰Sr, by increased it monotonically for ⁶⁰Co. The obtained α values were 40% and 60% for ⁹⁰Sr and ⁶⁰Co, respectively, at [LMC] = 5 g/l. A comparison of the results showed that the coprecipitation of all the elements studied was more effective on LMC than HMC.

To conclude, using chitosans for concentrating radionuclides from salt solutions could find practical use during not only ecological monitoring of natural waters, but also the reprocessing of low-level liquid waste.

The research was carried out using financial support by the Russian Fund for Fundamental Research (Grant N 11-03-00106).

A NEW FORMULATION OF EFFECTIVE STATES OF “ATOMS IN COMPOUNDS”. APPLICATION TO STUDY HYPERFINE STRUCTURES AND CHEMICAL SHIFTS OF X-RAY EMISSION LINES

Yu.V. Lomachuk^{1,2)}, L.V. Skripnikov^{1,2)}, A.V. Titov^{1,2)}

¹⁾ - *Petersburg Nuclear Physics Institute, Gatchina, Russia, titov@pnpi.spb.ru*

²⁾ - *Dept. of Physics, St. Petersburg State University, Petrodvoretz, Russia*

Concepts of oxidation number state of an *atom in a molecule* and related theories are extremely useful in chemistry. At the same time, a good (clear and unambiguous) definition of the state of an *atom in a molecule* does not exist. Various methods of determining it from calculations lead to different results [1]. Each of known definitions has its drawbacks. The methods based on the use of one-electron density matrices (Mulliken or Löwdin populations analyses, etc.) are basis set dependent. The methods that use the electron densities (Bader or Hirschfield charges, Voronoi cells), suggest introduction of some complementary (artificial) notions or partitioning a molecule (solid) on regions in a manner that is not arising from any of physical principles.

There is a number of experimentally observed properties of compounds, depending on a distribution of the valence electron densities or their changes in the atomic core regions. They include chemical shifts of X-ray emission spectra, hyperfine structure constants, isotope (volume) shifts, etc. Earlier our group has developed a two-step method to calculate these properties through first-principle based electronic structure calculations within the generalized relativistic pseudopotential approximation followed by a posteriori restoration of the information on the wave functions in the atomic core regions that is missed in the results of pseudopotential calculations [2]. On the basis of this two-step method one can formulate an approach for determining the state of an *atom in a molecule (compound)*. A radius R_c of the core region is determined by the smallness of interaction of valence electrons located within a sphere ($r < R_c$) with the external (chemical) environment ($r > R_c$) compared to their interaction with the nucleus and core electrons of a considered atom. Using the properties of proportionality of valence spinors in the atomic core region with the radius R_c [3], one introduce some new terms: “charges of partial waves” for valence electrons in the core region, “reduced population numbers” and one-center density matrices “reduced on the radial quantum number n_r ”. It is shown that the above-discussed properties characterized by the state of an *atom in a compound* rather than by chemical bonds are well described by only these terms. Results of calculations of the properties of atoms and molecules are presented.

The work is supported by the SPbU Fundamental Science Research grant from Federal budget #0.38.652.2013 and RFBR grant #13-03-01307-a.

[1] C.J.Cramer, *Essentials of Computational Chemistry: Theories and Methods*, (2002,Wiley).

[2] Titov A.V. et al., *Int. J. Quant. Chem.*, **104**(2), 223 (2005).

[3] Titov A.V., Mosyagin N.S., *Int. J. Quant. Chem.*, **71**(5), 359 (1999).

**SPECIATION OF HEPTAVALENT TECHNETIUM IN INORGANIC
ACIDS AND PERCHLORATE MEDIA**

**A.Ya. Maruk^{1,2)}, F. Poineau³⁾, P.F. Weck³⁾, A. Kirakosyan¹⁾, W. Lukens⁴⁾,
B. Burton-Pye⁵⁾, D.B. Rego³⁾, I. Denden⁶⁾, E.V. Johnstone³⁾,
A.P. Sattelberger⁷⁾, M. Fattahi⁶⁾, L. Francesconi⁵⁾, K.R. Czerwinski³⁾,
K.E. German^{1,8)}**

- ¹⁾ - *A. N. Frumkin Institute of Physical Chemistry and Electrochemistry, Russian Academy of Sciences, 119991 Moscow, Russian Federation, e-mail: amaruk@list.ru*
- ²⁾ - *Burnasyan Federal Medical Biophysical Center of FMBA of Russia, 123182 Moscow, Russian Federation*
- ³⁾ - *Department of Chemistry, University of Nevada Las Vegas, Las Vegas, NV 89154, USA*
- ⁴⁾ - *Chemical Sciences Division, Lawrence Berkeley National Laboratory, Berkeley, CA 94720, USA*
- ⁵⁾ - *Department of Chemistry, Hunter college, New-York, USA*
- ⁶⁾ - *Laboratory Subatech, Ecoles des Mines de Nantes, Nantes, France*
- ⁷⁾ - *Energy Engineering and Systems Analysis Directorate, Argonne National Laboratory, Lemont, IL, USA*
- ⁸⁾ - *Moscow Branch of Medical Institute REAVIZ, Moscow, Russian Federation*

The speciation of Tc(VII) in concentrated H₂SO₄, HClO₄, HNO₃ and NaClO₄ has been performed by ⁹⁹Tc NMR, UV-visible and XAFS spectroscopy. In H₂SO₄ and HClO₄, the representation of the ⁹⁹Tc chemical shift vs. TcO₄⁻ is consistent with the formation of a new Tc(VII) species above 7 M H₂SO₄ and 8 M HClO₄ and is complete at ~ 12 M H₂SO₄ and HClO₄. Experimental XAFS results and density functional calculations showed the formation of TcO₃(OH)(H₂O)₂. It is likely that an acido- basic phenomenon is responsible for the formation of these species. In 1-15 M HNO₃, TcO₃(OH)(H₂O)₂ was not observed and the ⁹⁹Tc NMR results are consistent with the presence of TcO₄⁻. The ⁹⁹Tc NMR chemical shift monotonically decreases as the acid concentration increase. Interestingly, a similar phenomenon occurs in 1-7 M H₂SO₄ and HClO₄. Aqueous solutions of TcO₄⁻ in 0.5 - 6 M NaClO₄ were examined by ⁹⁹Tc NMR spectroscopy. It was found that the presence of NaClO₄ in the absence of HClO₄ also resulted in negative ⁹⁹Tc chemical shift. It appears that the presence of a strong electrolyte affects the coordination environment of the Tc atom. In NaClO₄ / HClO₄ mixture, it was found that the chemical shift is deflected into positive region as the acid concentration increases. All this results suggests that polarizing effect on the TcO₄⁻ ion and its reactivity with H⁺ and H₃O⁺ are two separate parallel processes and will be discussed in this presentation.

**TECHNETIUM AND RHENIUM PENTACARBONYL
PERCHLORATES AS PRECURSORS FOR HIGHER CARBONYL
COMPLEXES OF TECHNETIUM AND RHENIUM**

**A.E. Miroslavov¹⁾, V.V. Gurzhiy²⁾, M.Yu. Tyupina¹⁾, A.A. Lumpov¹⁾,
G.V. Sidorenko¹⁾, Yu.S. Polotskii¹⁾, D.N. Suglobov¹⁾**

¹⁾ - *Khlopin Radium Institute, 2-i Murinskii pr. 28, St. Petersburg,
194021 Russia; e-mail: amiroslav@mail.ru*

²⁾ - *St. Petersburg State University, Universitetskaya nab. 7/9, St. Petersburg,
199034 Russia*

Carbonyl perchlorates $[M(\text{ClO}_4)(\text{CO})_5]$ ($M = \text{Tc}, \text{Re}$) were prepared by heterogeneous reaction of $[\text{MX}(\text{CO})_5]$ ($M = \text{Tc}, \text{X} = \text{I}; M = \text{Re}, \text{X} = \text{Cl}$), with AgClO_4 in dichloromethane at room temperature. The complexes were isolated in the form of yellowish and colorless crystals, respectively. The IR spectrum of $[M(\text{ClO}_4)(\text{CO})_5]$ ($M = \text{Tc}, \text{Re}$) in CH_2Cl_2 in the carbonyl range contains three characteristic bands at 2167.8 w, 2073.3 s, 2017.4 m ($M = \text{Tc}$) and at 2165.9 w, 2059.8 s, 2005.8 m ($M = \text{Re}$). The ^{99}Tc NMR spectrum of $[\text{Tc}(\text{ClO}_4)(\text{CO})_5]$ in CH_2Cl_2 contains a single sharp (Δ 320 Hz) signal at -1353 ppm. $[\text{Re}(\text{ClO}_4)(\text{CO})_5]$ is stable in an inert solvent at least for 3 days, whereas $[\text{Tc}(\text{ClO}_4)(\text{CO})_5]$ in dichloromethane is stable only for several hours because of chlorine abstraction from the solvent. The molecular structure of technetium and rhenium pentacarbonyl perchlorates, determined by single crystal X-ray diffraction, is shown in Figs. 1a and 1b. The perchlorate anion is coordinated in the monodentate fashion.

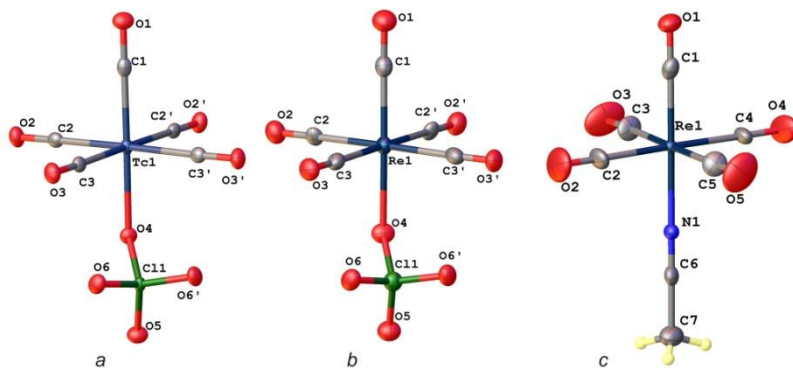

Fig. 1. Molecular structure of
(a) $[\text{Tc}(\text{CO})_5(\text{ClO}_4)]$,
(b) $[\text{Re}(\text{CO})_5(\text{ClO}_4)]$ and
(c) $[\text{Re}(\text{CO})_5(\text{CH}_3\text{CN})]\text{ClO}_4$.

Perchlorate ligand in the coordination sphere of $[M(\text{ClO}_4)(\text{CO})_5]$ ($M = \text{Tc}, \text{Re}$) can be readily substituted by a molecule of a coordinating solvent (acetonitrile) to form $[M(\text{CO})_5(\text{CH}_3\text{CN})]\text{ClO}_4$. The molecular structure of $[\text{Re}(\text{CO})_5(\text{CH}_3\text{CN})]\text{ClO}_4$, determined by single crystal X-ray diffraction, is shown in Fig. 1c. The Re species appeared to be stable in acetonitrile under ambient conditions, whereas the corresponding Tc species undergoes rapid decarbonylation in acetonitrile to form the known $[\text{Tc}(\text{CO})_3(\text{CH}_3\text{CN})_3]\text{ClO}_4$.

Thus, $[M(\text{ClO}_4)(\text{CO})_5]$ ($M = \text{Tc}, \text{Re}$) are convenient precursors for preparing various higher carbonyl complexes of technetium and rhenium in noncoordinating solvents.

**CHEMISTRY OF SUPERHEAVY ELEMENTS THROUGH
RELATIVISTIC ELECTRONIC STRUCTURE MODELING**

**N.S. Mosyagin¹⁾, Yu.A. Demidov¹⁾, L.V. Skripnikov¹⁾, A.A. Rusakov²⁾,
A.V. Zaitsevskii^{1,3)}, A.V. Titov¹⁾**

¹⁾ – *FSBI “Petersburg Nuclear Physics Institute”, Gatchina, Leningrad district 188300, Russia, e-mail: mosyagin@pnpi.spb.ru*

²⁾ – *P.G. Demidov Yaroslavl State University, Yaroslavl, Sovetskaya st. 14, 150000, Russia*

³⁾ – *NRC “Kurchatov Institute”, Kurchatova sq. 1, Moscow, 123182 Russia*

Recent advances in first-principle based studies of superheavy element (SHE) chemistry using the shape-consistent two-component small-core pseudopotential model are summarized. This model accounts for the finite nuclear size and incorporates relativistic effects (including the bulk of Breit interactions) and enables explicit correlation of both valence and subvalence electrons, providing a good basis for attaining optimal accuracy/cost ratio in the cases of large and strongly interfering relativistic and correlation effects characteristic for the SHE compounds. Depending on the size of systems under study and required accuracy, high-level relativistic wavefunction theory (mainly coupled-cluster) and density functional theory methods or their combinations were used to solve the electron correlation problem.

Because of the exceptional role of thermochromatography on gold in the experiments on the “chemical” identification of SHEs with atomic numbers $Z \geq 112$, main attention was paid to the description of the SHEs – gold interactions. Adsorption energies of SHEs on gold surface were estimated using the cluster model. Its reliability was improved by monitoring charge distributions in the vicinity of the adsorption site and taking into account the effects of relaxation of the cluster compatible with its embedding into the crystal. In some cases the results differ significantly from those of previous theoretical studies. For instance, the new estimates of E113/Au and E120/Au adsorption energies (1.0-1.2 eV and 2.5-2.7 eV respectively) are recommended.

Further development of the SHEs “chemical” identification techniques may benefit from having a broader view of their chemical properties. We performed systematical relativistic calculations of molecular structures and energetics of presumably stable binary compounds of SHEs with the most common light elements. The obtained results along with the similar data for the homologues of SHEs were visualized through the “chemical graphs” which reflect the main trends in changing basic gas-phase chemical properties of the elements in the given group of the periodic table and demonstrate the specificity of SHEs.

The work is partially supported by the RFBR (grants No. 13-03-01307 and No. 13-03-12252-ofi_m-2013). AAR gratefully acknowledges research support within the State Task to YSU on Scientific Research, Project № 3.7900.2013. Thanks are due to Prof. C. van Wüllen for supplying us with his relativistic DFT code. The calculations were performed at MCC NRC “Kurchatov Institute” (<http://computing.kiae.ru/>) and P.G. Demidov Yaroslavl State University (<http://it-park.yar.ru/Cluster/general.php>).

Np(V) SOLUBILITY IN NaCl AND MgCl₂ SOLUTIONS

V.G. Petrov¹⁾, X. Gaona²⁾, D. Fellhauer²⁾, J. Rothe²⁾, K. Dardenne²⁾,
S.N. Kalmykov¹⁾, M. Altmaier²⁾

¹⁾ - *Lomonosov Moscow State University, Department of Chemistry, 119991, Leninskie gory, 1/3, Moscow, Russia*

²⁾ - *Karlsruhe Institute of Technology, Institut für Nukleare Entsorgung, P.O. Box 3640, 76021 Karlsruhe, Germany*

Actinides solubility in chloride media is of particular interest for the final radioactive waste disposal in underground salt formations (e.g. WIPP in USA and Asse salt mine in Germany). In the case of water intrusion into repository NaCl and MgCl₂ will be the main components of brines. In high level wastes ²³⁷Np is considered as a relevant dose contributor in the long term and as the potentially mobile due to the high stability of its pentavalent oxidation state which under many conditions has a higher solubility in comparison with the tri-, tetra- and hexavalent actinides.

In this study solubility of pentavalent neptunium hydroxide was investigated in NaCl and MgCl₂ solutions of different ionic strengths (in molar units): 0.1 – 5 M (for NaCl), 0.1 – 4.5 M (for MgCl₂). To exclude possible influence of colloidal particles experiments were carried out in “undersaturation” mode. In the case of MgCl₂ media the maximum concentration of hydroxide in solution (pH_{max}) was fixed by the precipitation of magnesium hydroxide or magnesium oxochloride [1]. Further shift of pH_m to less alkaline values was achieved with HCl/MgCl₂ solutions.

It was shown that in NaCl solutions with ionic strengths >1 M green neptunium hydroxide transforms to white or violet-pink sodium neptunates. In contrast no visible transformation of solid phase was observed within the solubility experiments in MgCl₂ system, so only green amorphous pentavalent neptunium hydroxide was assumed as a solubility-limiting solid phase.

Additional experiments in “oversaturation” mode were carried out in 0.25 and 2.11 m MgCl₂ solutions to investigate the possible formation of Mg-Np(V)-OH ternary solid phases as previously observed for the Ca-Np(V) system. No difference in comparison with “undersaturation” mode was observed: solid phase retained the green colour and Np concentration remained almost constant.

Thermodynamic modelling will be completed after the characterization of solid and aqueous phases by methods of XAS and UV-Vis-spectrophotometry. XAS spectra of solid samples will be measured at the INE beamline for actinide research at ANKA.

This work was supported by ACTINET-i3 Integrated Infrastructure Initiative, the Ministry of Education and Science of Russian Federation (Contract 11.519.11.5011) and Russian Foundation for Basic Research (grant 12-03-31548).

[1] Altmaier M., Metz V., Neck V., Müller R., Fanghänel T. Solid-liquid equilibria of Mg(OH)₂(cr) and Mg₂(OH)₃Cl·4H₂O(cr) in the system Mg-Na-H-OH-Cl-H₂O at 25°C. *Geochimica et Cosmochimica Acta*, 2003, vol. 67, 3595–3601.

CURIUM-TECHNETIUM COMPLEX OXIDE

E.M. Pichuzhkina, S.V. Tomilin

Joint Stock Company “State Scientific Center – Research Institute of Atomic Reactors”, Dimitrovgrad, orip@niiar.ru

Over a number of years, RIAR has been synthesizing and studying transplutonic compounds, in particular, curium and americium compounds with other elements of the periodic system.

This paper presents the results of synthesis and study of an unknown tertiary oxide based on curium-244 and technetium generated when studying curium-244 and technetium alloying. The compound was generated by condensing metal curium vapor onto a metal technetium substrate. Mixed oxide $\text{Cm}_6\text{TcO}_{12}$ with hexagonal lattice of $\text{Ho}_6\text{MoO}_{12}$ type was identified by X-raying and characterized. The planar spacing and crystalline lattice parameters were identified as ($a = 10,552(3) \text{ \AA}$, $c = 9,879(5)\text{\AA}$).

The crystalline lattice of this compound was found to be stable to the long-term internal self-irradiation of curium-244; the complete amorphisation was not observed even after 1000 days of exposure, though the diffraction picture intensity decreased significantly. During the time period of ~1000 days, phase $\text{Cm}_6\text{TcO}_{12}$ accumulated about $2 \cdot 10^{20} \text{ \alpha-dec/g}$; it remained crystalline and underwent some swelling, mainly at the beginning of self-irradiation.

**STUDY OF CERIUM OXIDE NANOPARTICLES SOLUBILITY
USING A RADIOACTIVE ISOTOPE ^{141}Ce**

**T.V. Plakhova¹⁾, A.Yu. Romanchuk¹⁾, V.K. Ivanov²⁾, D. Shuh³⁾,
S.N. Kalmykov¹⁾**

¹⁾ - Lomonosov Moscow State University, Moscow, Russia

*²⁾ - Kurnakov Institute of General and Inorganic Chemistry of RAS,
Moscow, Russia*

*³⁾ - Lawrence Berkeley National Laboratory, USA
tatiana.v.plakhova@gmail.com*

Recently, there has been an increased interest in nanocrystalline cerium oxide due to its unique physical properties and wide range of possible applications in the field of catalysis, sensorics, biomaterials, etc. Ceria nanoparticles exhibit a good chemical and thermal stability and excellent biological compatibility. However, there's still a lack of knowledge concerning CeO_2 solubility in aqueous solutions, $\text{Ce}^{3+}/\text{Ce}^{4+}$ surface ratio and related characteristics determining catalytic and biological activity of nano-ceria.

The present study was aimed to determine the solubility of cerium dioxide nanoparticles using radioactive ^{141}Ce marker and to study $\text{Ce}^{3+}/\text{Ce}^{4+}$ ratio on the surface of nanoparticles.

Synthesis of ceria nanoparticles with radioactive marker was carried out by adding aqueous ammonia to cerium(III) nitrate stock solution containing ^{141}Ce . The precipitate was washed with deionized water and split to several portions for solubility study as a function of pH.

The size and shape of ceria nanoparticles was determined using high-resolution transmission electron microscopy (HRTEM). Selected area electron diffraction (SAED) patterns were used to confirm crystallinity of samples and to calculate lattice parameters of nanoparticles. Scanning transmission X-ray microscopy (SXTM) was used for O and Ce elemental mappings and X-ray absorption (XAS) spectra at the O-K-edge and Ce- $M_{5,4}$ -edge in order to get information on ceria oxidation state at the surface of nanoparticles. The solubility was determined by measuring ^{141}Ce isotope concentration with γ -spectroscopy technique.

According to HRTEM data ultrafine CeO_2 nanoparticles with fluorite crystal structure were formed. A strong correlation between concentration of Ce(III) nitrate precursor solution and ceria nanoparticle size was observed. According to SXTM mapping there is a uniform distribution of Ce and O in all the samples. Solubility experiments were performed in the range of pH from 2 to 12 using two specimens with 2 nm and 5 nm average crystallite size. Upon the raise of pH significant decrease in solubility was observed (from 10^{-5} M at pH 2 to 10^{-9} M at pH 8). Kinetic experiments indicate that equilibrium is reached in approximately 1 month.

TECHNETIUM BINARY HALIDES

F. Poineau¹⁾, E.V. Johnstone¹⁾, A.P. Sattelberger²⁾, K.R. Czerwinski¹⁾

*¹⁾ - Department of Chemistry, University of Nevada Las Vegas, Las Vegas, NV
89154, USA*

*²⁾ - Energy Engineering and Systems Analysis Directorate, Argonne National
Laboratory, Lemont, IL, USA*

Technetium is the lightest radioelement and the last transition metal to be discovered. Study of simple Tc binary halides is essential to the understanding of the chemistry of this element; it is also relevant to nuclear and medical applications: development new waste form materials and new imaging agent for the nuclear medicine. Prior 2008, technetium divalent and trivalent binary chlorides were unknown and only three Tc binary halides were unambiguously characterized: TcF₆, TcF₅, and TcCl₄; today, nine phases are known. Historically, the first technetium binary halide to be reported was technetium tetrachloride in 1957. The discovery of TcCl₄ was followed by the one of TcF₆ in 1961 and TcF₅ in 1963; both fluorides were obtained from the reaction of Tc metal and F₂ gas. The structure of the hexafluoride consists of TcF₆ octahedron while TcF₅ is isostructural to MF₅ (M = Re, Cr) and consists of corner sharing TcF₆ octahedra.

The absence of Tc trivalent chloride was surprising considering the existence of such compounds for all the element surrounding technetium. The presence of trichloride has been shown in the gas but the preparation of Tc₃Cl₉ has been attempted without success. The synthesis strategies used to obtain binary halides (i.e., stoichiometric reaction between the element in a sealed tube, and flowing gas reaction between a preformed dimer and HX gas, X = Cl, Br, I) have not been reported for technetium. In this context, we investigated the synthetic chemistry of technetium chlorides and bromides; over the past five years, we reported seven new technetium binary phases: TcBr₄, TcBr₃, α/β -TcCl₃, α/β -TcCl₂ and prepared several compounds derived from this phase. In this presentation, the preparation, structure and properties of technetium binary chlorides and bromides will be reviewed.

AMERICIUM ALLOYS WITH GOLD AND COPPER

V.M. Radchenko, M.A. Ryabinin, T.A. Chernakova, S.V. Tomilin,
E.M. Pichuzhkina

Joint Stock Company “State Scientific Center – Research Institute of Atomic Reactors”, Dimitrovgrad, orip@niar.ru

Over many years JSC “SSC RIAR” has been performing activities on the production and investigation of metals of transplutonium elements (TPE), their alloys and compounds. This paper presents the results of production and X-ray examination of micro-samples of americium-241 compounds with gold and copper, i.e. identification of crystal structures of the compounds obtained and calculation of crystal lattice parameters, study of the effect of alpha-decay on the intermetallide crystal structures. Samples of Am-Au and Am-Cu systems were prepared by high temperature condensation of metal americium vapor onto appropriate substrates. The X-ray examination results of the compounds produced are shown in the table below.

Table. Crystal lattice parameters of phases detected during investigation of Am-Au and Am-Cu systems

System	Phase	Syngony (space group)	Lattice parameters			
			<i>a</i> , Å	<i>b</i> , Å	<i>c</i> , Å	<i>V</i> , Å ³
Am-Au	Au ₆ Am	Tetragonal (<i>P4₂/ncm</i>)	10.3894(7)	-	9.7036(7)	1047.4(2)
	AuAm	Orthorhombic (<i>Pnma</i>)	7.402(2)	4.564(1)	5.826(1)	196.8(1)
	AuAm	Cubic (<i>Fm3m</i>)	4.784(2)	-	-	-
Am-Cu	Cu ₅ Am	Hexagonal (<i>P6/mmm</i>)	4.958(1)	-	4.175(2)	88.88(5)

Note. *V* – is volume of a crystal lattice elementary cell. Definition errors of the last character are given in brackets after the lattice parameter values.

The investigated systems did not show mutual solubility of their components at room temperature. In the Am-Au system three intermetallic compounds were found: Au₆Am (of Au₆Sm structural type), AuAm (of CuCe structural type) and intermetallide AuAm (of CsCl structural type). In the Am-Cu system intermetallide Cu₅Am (Cu₇Am) (of Cu₅Ca structural type) was detected. The effect of alpha-activity of nuclide ²⁴¹Am on crystal structure of the obtained intermetallide (Fig.) was investigated.

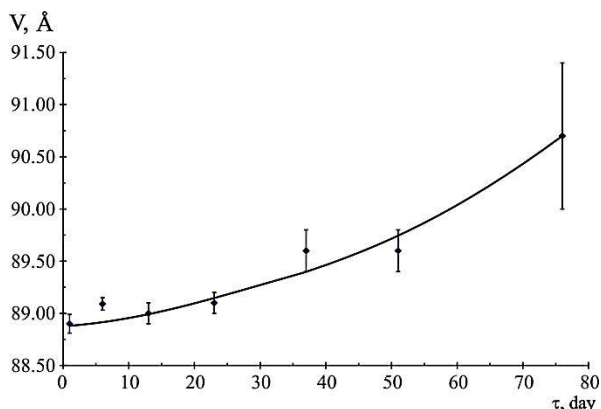

Fig. Change in the elementary cell volume of intermetallide Cu₅Am as a function of self-irradiation time.

ATOMIC TRITIUM PROBE IN THE INVESTIGATION OF IONIC SURFACTANT ADMIXTURES INFLUENCE ON LYSOZYME ADSORPTION LAYER

I.A. Razzhivina¹⁾, M.G. Chernysheva¹⁾, A.L. Ksenofontov²⁾, O.A. Soboleva¹⁾, G.A. Badun¹⁾

¹⁾ - *Dpt. Chemistry*, ²⁾ - *N. Belazerskiy Institute of Physico-Chemical Biology, Lomonosov Moscow State University, Moscow, Russia 119991*
E-mail: irina.razzhivina@yandex.ru

The term “atomic tritium probe” involves the treatment of molecules or molecular aggregates with the atomic tritium followed by analysis of intra- and intermolecular tritium distribution. The method is promised for the investigation of surfactants interaction with macromolecules in mixed adsorption layers formed at the air/water surface. The accessibility or vice versa shielding of macromolecule regions to atomic tritium relates either its structural peculiarities or contacts with other compounds in the system. In present work the investigation of surfactants admixtures influence on lysozyme adsorption layers structure at the air/ aqueous solutions surface was carried out. The data obtained by atomic tritium probe were completed by tensiometry, fluorescence and circular dichroism spectroscopy.

The experiment was performed for fixed lysozyme concentration (0.34 mg/ml) and varied concentrations of ionic surfactants: sodium dodecyl sulfate (SDS) or dodecyltrimethylammonium bromide (DTAB). Lysozyme-surfactant mixtures in molar ratios from 1:1 to 1:10 in phosphate buffer saline (pH 7.2, 0.16 M) were incubated at 25°C during 24 hours for setting equilibrium processes. The reaction with atomic tritium was carried out according to the procedure described in Ref [1]. After lysozyme purification protein was subjected to total hydrolysis followed by analysis of radioactivities of each amino acid residue.

The significant decrease of total accessibility of protein itself and amino acid residues was observed for lysozyme-DTAB mixture even at protein-surfactant molar ratio 1:1, when the surface tension is controlled by protein. Further increase in DTAB concentration increases protein shielding resulting in radioactivity reduction.

In lysozyme-SDS system the decrease of both the surface tension and total accessibility of protein to atomic tritium was observed. However growth of surfactant concentration leads to the increase of protein specific radioactivity due to the increase of radioactivity of positively charged amino acid residue.

The data obtained indicates changes in the adsorption layer structure even at low detergent concentrations. Differs in mechanisms of lysozyme – surfactants interaction are discussed in the report.

[1] Lukashina E.V., Badun G.A., Chulichkov A.L. *Biomol. Eng.* 2007, 24, 125-129.

NUCLEAR-CHEMICAL SYNTHESIS OF NEW NUCLEOGENIC CATIONS – PRECURSORS FOR UNKNOWN BIOLOGICALLY ACTIVE HETEROCYCLIC DERIVATIVES

N.E. Shchepina¹⁾, V.V. Avrorin²⁾, G.A. Badun³⁾

¹⁾ – *Natural Sciences Institute of Perm State University, 4, Genkel St., Perm, 614990, Russia, neshchepina@mail.ru*

²⁾ – *St-Petersburg State University, 26 Universitetsky Pr., St-Petersburg, Petrodvorets, 198504, Russia, radiochem@yandex.ru*

³⁾ – *M.V. Lomonosov Moscow State University, Leninskie Gory, Moscow, 119992, Russia, badunga@yandex.ru*

It is known that fluoro-substituted heterocyclic derivatives mostly possess higher biologic activity in comparison with their unsubstituted ones. Previously we have been investigated ion-molecular reactions of nucleogenic phenyl cations with the wide range of six-membered nitrogen heterocyclic compounds and have been elaborated one-step method of synthesis of biologically active tritium labeled different pyridinium derivatives – effective biological markers. In prolongation of investigated nuclear-chemical method unusual fluoro-substituted phenyl cations have been obtained.

The source of new nucleogenic cations – ditritium labeled difluorobenzene was synthesized by reaction of catalytic substitution. Tritium labeled difluorophenyl cations were generated by spontaneous tritium β -decay:

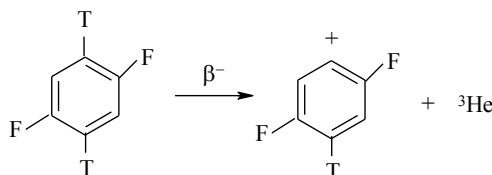

The proposed scheme for the ion-molecular interactions of nucleogenic difluorophenyl cations with nucleophilic centers of quinoline molecule may be represented in the following manner:

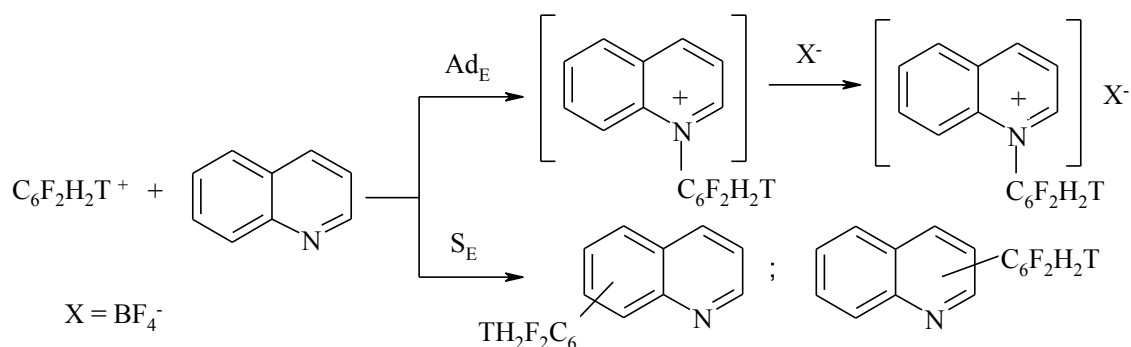

Unknown fluoro-substituted quinolinium compounds have been obtained with the high yield.

**REACTIVITY OF TECHNETIUM(I) TETRACARBONYL COMPLEXES:
EXPERIMENTAL AND QUANTUM-CHEMICAL STUDIES**

**G.V. Sidorenko¹⁾, A.E. Miroslavov¹⁾, D.A. Maltsev²⁾, A.A. Lumpov¹⁾,
M.Yu. Tyupina¹⁾, Yu.S. Polotskii¹⁾, D.N. Suglovov¹⁾**

¹⁾ - *Khlopin Radium Institute, 2-i Murinskii pr. 28, St. Petersburg,
194021 Russia; e-mail: gevasid@mail.ru*

²⁾ - *St. Petersburg State University, Universitetskaya nab. 7/9, St. Petersburg,
199034 Russia*

[TcBr(CO)₄]₂, which is formed as isolable intermediate in stepwise decarbonylation of [TcBr(CO)₅], is stable in an inert solvent at room temperature but rapidly reacts with acetonitrile. At room temperature, the reaction is complete in 2–3 h and follows the equation



The pseudo-first-order rate constant of the reaction at 292.5 K is $(2.88 \pm 0.14) \times 10^{-4} \text{ s}^{-1}$, exceeding the rate constant of the analogous reaction of [TcBr(CO)₅] $\{(1.21 \pm 0.03) \times 10^{-5} \text{ s}^{-1}$ at 298.4 K} by more than an order of magnitude. This result is consistent with the fact that probable intermediate [TcBr(CO)₄(CH₃CN)] in the reaction of [TcBr(CO)₅] with CH₃CN is not detected, because such intermediate should be more reactive than the starting complex.

Tc(Xan)(CO)₄ (Xan = S₂COCH₃), which undergoes slow decarbonylation in CCl₄ only on refluxing, reacts with CH₃CN at noticeable rate already at room temperature. The pseudo-first-order rate constants ($k \times 10^5, \text{ s}^{-1}$) are as follows: 300.6 K, 3.1 ± 0.3 ; 305.8 K, 7.2 ± 0.5 ; 310.1 K, 13.3 ± 0.3 ; 315.1 K, 26.0 ± 0.8 (activation energy 114 kJ mol⁻¹).

Thus, in contrast to technetium pentacarbonyl halides, which undergo decarbonylation in an inert solvent and CO replacement in CH₃CN at similar rates, the tetracarbonyl complexes react with CH₃CN considerably faster compared to decarbonylation in an inert solvent. This fact could be accounted for by transition from dissociative to associative mechanism of ligand replacement in going from penta- to tetracarbonyls. However, a DFT analysis of the dissociative (via five-coordinate intermediate) and associative (via seven-coordinate intermediate) reaction pathways shows that the dissociative pathway is more probable not only for pentacarbonyl halides, but also for [Tc(Xan)(CO)₄] and for the hypothetical complexes [TcBr₂(CO)₄]⁻ (simulating “half” of the dimer [TcBr(CO)₄]₂) and [TcBr(CO)₄(CH₃CN)] (probable intermediate in reaction of [TcBr(CO)₅] with CH₃CN). DFT analysis shows that the energy of CO detachment in CH₃CN from the tetracarbonyls is appreciably lower than from [TcBr(CO)₅], which is consistent with the higher reactivity of the tetracarbonyls in CH₃CN. Higher stability of the tetracarbonyl complexes, compared to pentacarbonyl halides, in CCl₄ is rationalized assuming formation of an unstable complex of the five-coordinate intermediate with the solvent (CCl₄) molecule. Owing to the labilizing effect of σ-donor ligands, the complex TcX₂(CO)₃·CCl₄ (X = halide, CH₃CN; X₂ = Xan) should be less stable than the complex TcX(CO)₄·CCl₄. Therefore, in the former case the back transformation into the starting species under the action of the released CO is more probable.

High reactivity of Tc tetracarbonyls in donor media restricts their applicability in nuclear medicine. Rhenium compounds, which are generally more inert, seem to be more promising.

XPS INVESTIGATION OF PuO₂

**Yu.A. Teterin¹⁾, K.I. Maslakov¹⁾, M.V. Ryzhkov²⁾, A.Yu. Teterin¹⁾,
K.E. Ivanov¹⁾, V.G. Petrov³⁾, D.A. Enina³⁾, S.N. Kalmykov³⁾**

¹⁾ - *NRC Kurchatov Institute, Moscow, Russia, teterin_ya@nrcki.ru*

²⁾ - *Institute of Solid State Chemistry UD RAS, Ekaterinburg, Russia,
ryz@ihim.uran.ru*

³⁾ - *Lomonosov Moscow State University, Moscow, Russia,
vladimir.g.petrov@gmail.com*

The XPS study of the electronic structure and physical and chemical properties, beside the chemical shifts (ΔE_b) and the peak intensities (I_0), can employ the core and valence spectral structure parameters. This structure can originate from the formation of the outer (0 eV - ~15 eV, OVMO) and the inner (~15 - ~35 eV, IVMO) valence molecular orbitals (MO), spin-orbit splitting (ΔE_{sl}), multiplet splitting (ΔE_{ms}), charge inducing (ΔE_{ind}), many-body perturbation (ΔE_{sat}), dynamic effect (gigantic Coster-Kronig transitions), Auger-process etc. If several of these effects show up in the XPS spectrum for a certain electronic level simultaneously at comparable probabilities, the correct interpretation of the spectrum is not possible. If these probabilities are different, the XPS structure parameters can characterize: degree of delocalization and participation of electrons in chemical bond; electronic configuration and oxidation states of ions; uncoupled electrons density at paramagnetic ions; degree of participation of the filled electronic shells of metals and ligands in the IVMO and the OVMO formation, the IVMO and the OVMO structures and nature, local environment structure, etc.

The BE range 0 eV to ~35 eV is especially important, since the XPS in this range reflects the MO structure and the valence electronic states densities (with the photoemission cross-sections in mind). However, the interpretation of the XPS structure in this BE range requires to understand how effective a certain extra structure formation mechanism is. To evaluate the contributions of different structure formation mechanisms to the valence XPS structure, one has to study the core (35eV to 1250 eV) XPS structures.

Taking into account the binding energy differences between the valence and the core electronic levels, XPS structure parameters and results of the relativistic calculation of PuO₂ electronic structure the composition and the sequence order of the inner valence molecular orbitals in the energy range from 13 eV to 35 eV were determined and the valence electronic states densities in the range 0 eV - 35 eV in plutonium dioxide were calculated. These data allowed the quantitative scheme of molecular orbitals for PuO₂. This scheme is fundamental not only for understanding the chemical bond nature in PuO₂, but also for interpretation the fine structure of other PuO₂ x-ray spectra.

The work was supported by RFBR grant 13-03-00214-a.

XPS STRUCTURE STUDY OF NpO₂

**Yu.A. Teterin¹⁾, K.I. Maslakov¹⁾, M.V. Ryzhkov²⁾, A.Yu. Teterin¹⁾,
K.E. Ivanov¹⁾, V.G. Petrov³⁾, D.A. Enina³⁾, S.N. Kalmykov³⁾**

¹⁾ - *NRC Kurchatov Institute, Moscow, Russia, teterin_ya@nrcki.ru*

²⁾ - *Institute of Solid State Chemistry UD RAS, Ekaterinburg, Russia,
ryz@ihim.uran.ru*

³⁾ - *Lomonosov Moscow State University, Moscow, Russia,
vladimir.g.petrov@gmail.com*

The present work has studied the XPS structure of NpO₂ as powder and films on platinum surface in the electron binding energy range 0 eV - 1250 eV and quantitatively analyzed the fine valence electrons XPS structure in the binding energy range 0 eV - ~35 eV taking into account the peak positions, and the fine core level spectral structure parameters, as well as the fully relativistic discrete variation (RDV) method calculation results for the finite fragment of NpO₂ crystal lattice was interpreted for the first time.

The fine x-ray photoelectron spectral structure of NpO₂ was studied in the binding energy range 0 eV - 1250 eV, the correlation of the XPS fine structure parameters and the mechanisms of its formation was established. Taking into account the binding energy differences between the core and valence electronic levels, as well as the relativistic calculation results of the electronic structure of the NpO₈ cluster, for the first time a quantitative interpretation of the x-ray photoelectron spectral structure of the outer (0 eV to ~15 eV BE) and the inner (~15 eV to ~35 eV BE) valence molecular orbitals for neptunium dioxide NpO₂ was done. The Np5f (1.06 Np5f e⁻) electrons were theoretically shown and experimentally confirmed to participate directly in the chemical bond formation in NpO₂. The quasiautomatic Np5f electrons (2.78 Np5f e⁻) were shown to be localized at 1.7 eV. The Np6p electrons, beside the effective (experimentally measurable) participation in the IVMO formation, were found to participate noticeably (~ 0.3 Np6p e⁻) in the filled OVMO formation in NpO₂. The most part in the IVMO formation in NpO₂ were shown to take the Np6p_{3/2} and the O2s atomic orbitals of the neighboring neptunium and oxygen. The MO sequent order in the binding energy range 0 eV - ~35 eV for NpO₂ was established, the MO composition was calculated. It allowed for the first time a fundamental quantitative MO scheme, which is important for understanding the chemical bond nature in NpO₂ and for the interpretation of other x-ray spectral structures of NpO₂.

The work was supported by RFBR grant 13-03-00214-a.

CHEMICAL SHIFTS OF X-RAY EMISSION SPECTRA IN HEAVY-ATOM MOLECULES AND SOLIDS: A NEW METHOD FOR DESCRIBING THE STATE OF ATOMS IN COMPOUNDS

A.V. Titov^{1,2)}, Yu.V. Lomachuk^{1,2)}, A.V. Zaitsevskii^{1,3)}, R.V. Bogdanov²⁾

¹⁾ – *Petersburg Nuclear Physics Institute, Gatchina, Russia, titov@pnpi.spb.ru*

²⁾ – *St. Petersburg State University, Petrodvoretz, Russia*

³⁾ – *National Research Center "Kurchatov Institute", Moscow, Russia*

Advantages of X-ray emission spectroscopy as a unique non-destructive method for determining the physical-chemical state of actinides in the bulk of complex materials are attenuated by the difficulty of interpreting the experimental data. Despite the obvious promise of establishing the relationship “spectrum – atomic state” through direct simulation of the electronic structure and spectra by quantum chemistry methods, this way is still not widely used due to both the extreme complexity of traditional schemes of relativistic calculations on solids or clusters and numerical instability of estimates for small chemical shifts evaluated as differences of large X-ray transition energies.

We propose a new efficient method for determining the chemical shifts through first-principle based electronic structure calculations within the relativistic pseudopotential approximation followed by a posteriori restoration of the information on the wave functions in the vicinity of the atomic nuclei that is missed in the results of pseudopotential calculations. Chemical shift of the transition energy is obtained directly as an expectation value of a certain quantum mechanical operator, thus reducing significantly the risk of numerical instabilities. The major advantage of the method consists in the fully relativistic (four-component) description of the core shells, with which the X-ray transition is associated, based on the two-component (taking into account the spin-dependent interactions or even one-component (scalar-relativistic) calculations on clusters or solids performed with explicit treatment of only valence and subvalence shells.

The results of our calculations of chemical shifts for the $K\alpha_{1,2}$ and L transitions of the group 14 metal cations with respect to the neutral atoms are presented. The computed chemical shifts for $K\alpha_1$ -line in the Pb-core transition in PbO and PbF₂ with respect to the neutral Pb are discussed. The accuracy of the used approximations and the reliability of the final results are analyzed. We also discuss the prospects of the proposed approach for evaluating and predicting the properties of mineral-ceramic matrices for immobilization of actinide fraction of high-level waste nuclear fuel cycle.

The work is supported by the SPbU Fundamental Science Research grant from Federal budget #0.38.652.2013 and RFBR grants 13-03-01307-a and 13-03-01234-a.

RECRYSTALLIZATION OF RADIUM-223 WITH BARIUM SULPHATE

N. Torapava¹⁾, C. Ekberg²⁾, H. Ramebäck³⁾, E. Curti⁴⁾

- ¹⁾ - *The Institute for Radioecology and Radiation Protection, Leibniz University of Hanover, Herrenhäuser Str. 2, 30419 Hanover, Germany*
- ²⁾ - *Department of Chemical and Biological Engineering, Nuclear Chemistry, Chalmers University of Technology, 41296 Gothenburg, Sweden*
- ³⁾ - *Swedish Defence Research Agency, Division of CBRN Defence and Security, 90182 Umeå, Sweden*
- ⁴⁾ - *Laboratory for Waste Management, Nuclear Energy and Safety Research Department, Paul Scherrer Institute, 5232 Villigen, Switzerland*

Radium is one of the radioactive elements that dominate the naturally occurring radioactive material (NORM) and its technically enhanced equivalent (TNORM). The main anthropogenic sources of radium are oil extraction and natural gas production, manufacturing of phosphoric acid, uranium mining and the storage of spent nuclear fuel [1-3]. Radium-226 increased activity will cause an elevation of the dose rate after ca. 300 000 years in a final repository for a spent nuclear fuel in Sweden. One of the main factors preventing radium release in the environment is the low solubility of radium sulfate. Short-lived radium-223 was used to study radium uptake with barite – a mineral present in the final repository. Using radium-223 decreases the detection limit below the picomolar level and avoids generating long-lived radioactive waste. It was shown that the system containing barite and simultaneously added radium-223 and barium-133 tracers follows the conventional homogeneous recrystallization model described by Curti et al [1].

The study of the kinetics of ²²³Ra/¹³³Ba recrystallization on the surface of synthesized barium sulfate crystals has been studied. The use of short-lived ²²³Ra isotope (half-life 11.4 days) allows reaching concentrations below 10⁻¹³ M as found in nature and avoids generation of long-lived radioactive waste. The addition of the second ²²³Ra²⁺ spike after 42 days allows detect a mechanism of recrystallization, i.e. while radium concentration of the second spike decreases, ¹³³Ba²⁺ concentration (no additional barium added) first, increases before it starts to decrease again. This may indicate the dissolution of a previously formed radiobarite, which releases barium and the formation of a new radiobarite after addition of the second radium spike.

[1] Curti et al. (2010) *Geochim. Cosmochim. Acta* **74**, 3553 – 3570.

COBALT RADIONUCLIDE SPECIATION IN AQUEOUS SOLUTION

V.V. Torapava, A.V. Radkevich

*Joint Institute for Power and Nuclear Research – Sosny NAS of Belarus,
Belarus, 220109 Minsk, A.K. Krasin st. 99, ireplab06@mail.ru*

Cobalt isotope ^{60}Co is the common component of liquid radioactive waste, generating by NPPs. Due to long half-life period, high decay energy and relatively high chemical mobility presence of ^{60}Co LRW usually determines its radiotoxicity and therefore treatment from ^{60}Co is the main problem.

Advanced liquid radioactive waste treatment technologies for cobalt removal include ion exchange, membrane separation, chemical precipitation, oxidation and reduction, and adsorption. The key point in the selection of technologies is state of cobalt in the solution. Cobalt in aqueous solutions exists as Co(II) or, rarely, Co(III) species and like other multicharged metal ions it hydrolyzes with increasing pH. Hydrolysis reactions lead to the formation of a variety of different species: mono- and polynuclear hydroxo complexes, colloidal particles and precipitates. Besides, formation of pseudocolloids, which can be removed from solution by membrane filtration or centrifugation, takes place at cobalt concentrations lower than 10^{-6} M, i.e. this process is the formation of colloids due to the metal ion sorption on the surface of foreign colloidal particles that are always present in solution in minor quantities. The formation of pseudocolloids is extremely important process in the case of solutions containing cobalt radionuclides. The variety of species and their different properties makes it possible to separate cobalt in aqueous solution. So the data on hydrolytic speciation can be a useful tool for development of various techniques for separation and selective extraction of cobalt.

Our work we aimed at finding methodology to study cobalt speciation based on selected literature data and our own research.

THE INFLUENCE OF NICKEL(II) AND CALCIUM(II) ON EUROPIUM(III) SORPTION AT VARIOUS OXIDE MINERALS WITH DIFFERENT SURFACE PROPERTIES

S. Virtanen, J. Knuutinen, N. Huittinen, J. Lehto

University of Helsinki, Department of Chemistry, Laboratory of Radiochemistry, P.O. Box 55, 00014 University of Helsinki, sinikka.m.virtanen@helsinki.fi

Studies on the competitive sorption of metals are usually conducted by using metals with similar chemical properties, such as oxidation state. A study by Bradbury and Baeyens [1] suggests that metal ion sorption on clay minerals is non-competitive when metals have clearly different chemical properties. This would imply that metals are not mutually competitive but rather that competition is selective. Metals with similar chemical properties, such as oxidation states and a similar tendency towards hydrolysis, compete with one another while metals with different chemistries do not. The influence of the presence of Ni(II) and Ca(II) on the Eu(III) sorption at oxide minerals TiO₂, ZrO₂ and α-Al₂O₃ is investigated with batch sorption experiments. The oxide minerals were chosen based on their different surface charge properties. The p*H*_{IEP} was found to be at 3.5-4.0 for TiO₂, at 6.0-7.2 for ZrO₂ and at 9.0-9.5 for α-Al₂O₃. The p*H*-dependent surface hydroxyl groups of the oxides act as ligands for metal ion surface complexation reactions, hence the surface charge can affect the sorption tendency of metals.

Batch sorption studies are conducted by using ¹⁵²Eu with and without stable Ni or Ca in buffered solutions as p*H* isotherms. The concentration of Ni and Ca in solution and the solid/liquid ratio are kept constant, whereas the europium concentration is varied. Experiments are conducted by using different Ni and Ca concentrations. All experiments are performed in a glove box, under N₂ atmosphere to prevent the formation of metal-carbonato complexes. At the present, only individual sorption data for Eu(III) and Ni(II) on TiO₂ and α-Al₂O₃ are available (Figure 1). Eu(III) sorption to oxides is stronger if compared with Ni(II) sorption and stronger complexation strength is observed for TiO₂ compared with α-Al₂O₃. The competitive sorption experiments are currently on-going and results will be presented at the symposium.

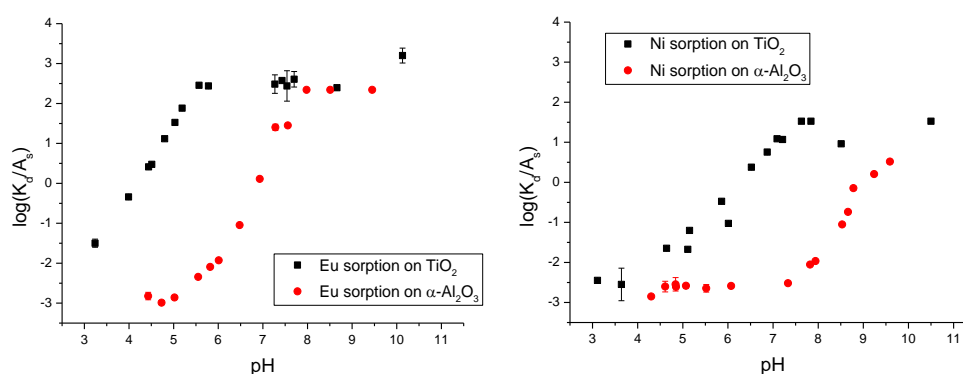

Fig. 1. Specific surface area normalized sorption distribution values K_d/A_s (L/m^3) for Eu and Ni ($2 \cdot 10^{-6}$ M) on TiO₂ and α-Al₂O₃ (2 g/L) in 0.01M NaClO₄.

[1] Bradbury M. H. and Baeyens B., (2005) Experimental measurements and modelling of sorption competition on montmorillonite, *Geochimica et Cosmochimica Acta*, **69**, 4187-4197.

**HIGHER OXIDES OF EARLY TRANSURANIUM ELEMENTS:
RELATIVISTIC MODELING OF MOLECULAR STRUCTURES**

A.V. Zaitsevskii^{1,2)}, N.S. Mosyagin¹⁾, A.V. Titov¹⁾, Yu.M. Kiselev³⁾

- ¹⁾ – *Petersburg Nuclear Physics Institute, Orlova Roshcha, Gatchina, 188300
Russia, azaitsevskii@pnpi.spb.ru*
- ²⁾ – *NRC “Kurchatov Institute”, 1 Kurchatov sq., Moscow, 123182 Russia*
- ³⁾ – *Chemistry Dept., Moscow State University, Vorob'evy Gory, Moscow
119899, Russia, yu_m@mail.ru*

In spite of several experimental evidences of the existence of higher oxides of plutonium, americium, and curium, and significant attention paid to these oxides because of their hypothetical role in the volatilization of the two former elements from oxidative media, reliable information on these species is extremely scarce. We report the results of two-component relativistic DFT electronic structure calculations on simple molecules of higher oxides (actinide oxidation state VI through VIII) and peroxides of Pu, Am, and Cm. The calculations employed accurate “small-core” two-component pseudopotentials, hybrid approximations for the exchange-correlation functional and flexible contracted Gaussian bases. Ground-state equilibrium structures, harmonic vibrational frequencies and main parameters of gas-phase thermodynamics were determined; electronic density distributions were analyzed in terms of Bader atomic charges.

All “true” An(VIII) oxides (An = Pu, Am, Cm), both monomers and dimers, were predicted to be thermodynamically unstable in realistic gas-phase conditions with respect to the decay into lower oxides (An₂O₆ or An₂O₇) and molecular oxygen as well as to the conversion into dioxoperoxides AnO₂(O₂). It is probable that the experimentally detected volatile compounds with presumable stoichiometry AnO₄ are peroxides. The stability of higher oxidation states rapidly decreases from Pu to Am and further to Cm. The formation of heterooxide molecules PuAmO₆ and especially PuAmO₇ from the corresponding pure oxides (An₂O₆ and An₂O₇) should be accompanied by a decrease in energy; one can suppose that the experimentally observed enhancement of the volatilization of an americium compound from alkaline solutions under ozonation in the presence of plutonium is related to the particular stability of these heterooxides.

A strong correlation between Bader net charges of actinide atoms in AnO_n and An₂O_n molecules and formal An oxidation state was detected. Charge distribution analysis allowed us to identify PuAmO₇ as mixed oxide of Pu(VII) and Am(VII), and not of Pu(VIII) and Am(VI), as could be supposed on the basis of structure data.

The work is partially supported by the RFBR (grants # 13-03-01234 and 13-03-01307). Thanks are due to Prof. C. van Wüllen for providing us with his relativistic DFT code. The calculations were performed at MCC NRC “Kurchatov Institute” (<http://computing.kiae.ru/>).

2. Nuclear Fuel Cycle, Nuclear Waste Treatment and Disposal

THE BEHAVIOR OF THE BETA-RADIOACTIVE FISSION PRODUCTS IN FAST NEUTRON IRRADIATED URANIUM-PLUTONIUM NITRIDE NUCLEAR FUEL

A.V. Androsov¹⁾, G.S. Bulatov²⁾, K.N. Gedgovd²⁾, D.Yu. Lyubimov¹⁾

¹⁾ – FSUE SRI SIA “LUCH”, Podolsk, RF

²⁾ – IPCE RAS, Moscow, RF

E-mail: gedgovd@ipc.rssi.ru

The thermodynamic analysis of the chemical and phase composition of fast neutron irradiated uranium-plutonium nitride (U_{0,8}Pu_{0,2})N_{0,995} at 900 K and burn up to 14 % heavy atoms is performed using the software package ASTRA-4.

It is shown that the accumulation of metal fission products leads to the formation of a multi-component solid solution based on nitrides of uranium and plutonium containing Am, Np, Zr, Y and lanthanides, as well as some of condensed phases: U₂N₃, CeRu₂, Ba₃N₂, CsI, Sr₃N₂, LaSe, metal molybdenum and technetium and intermetallic U(Ru,Rh,Pd)₃. It was calculated amount and composition of these phases in this range burn up at 900 K.

In connection with the β⁻ - decay of radioactive isotopes in the spent fuel, its phase composition will vary. Calculation of transformation kinetics of radio nuclides was carried out by a system of equations β⁻ - decay:

$$\frac{dy_i(t)}{dt} = -\delta_i \cdot \lambda_i \cdot y_i(t) + \eta_{i-1} \cdot \lambda_{i-1} \cdot y_{i-1}(t),$$

where y_i(t) - the concentration phase containing i-th radionuclide, y_{i-1}(t) - the concentration phase containing preceding chain β⁻ - decay of the radionuclide, λ_i - β-decay constant of the i-th radionuclide, δ_i and η_i - stoichiometric transformation coefficients phase chemical reactions, t-time.

The initial values of radionuclide concentrations of the compounds were calculated by taking into account their relative cumulative output by dividing the ²³⁸U and ²³⁹Pu.

Found that β⁻ - metallic radioactive decay of fission products leads to a change in the chemical and phase composition of the irradiated uranium-plutonium nitride. Calculated transformation kinetics

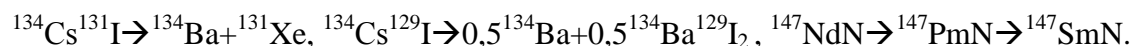
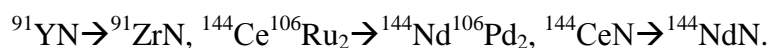

It is shown that ⁹¹YN transformed into a phase ⁹¹ZrN during 300 days, ¹⁴⁴Ce¹⁰⁶Ru₂ becomes ¹⁴⁴Nd¹⁰⁶Pd₂ for 1200 days, ¹⁴⁴CeN in ¹⁴⁴NdN for 1400 days,

¹³⁴Cs¹³¹I in ¹³⁴Ba+¹³¹Xe for 10 years, ¹³⁴Cs¹²⁹I in 0,5¹³⁴Ba+0,5¹³⁴Ba¹²⁹I₂ for 10 years, ¹⁴⁷NdN in ¹⁴⁷PmN for 55 days, and ¹⁴⁷PmN in ¹⁴⁷SmN for 13 years.

**SYNTHESIS, MICROSTRUCTURE AND PHYSICAL-MECHANICAL
PROPERTIES OF MONAZITE-TYPE CERAMICS FOR THE
CONDITIONING OF MINOR ACTINIDES**

**Y.A. Arinicheva, S. Neumeier, A.A. Bukaemskiy, F. Brandt, G. Modolo,
D. Bosbach**

*Forschungszentrum Jülich GmbH, IEK-6, Nuclear Waste Management,
Wilhelm-Johnen-Str., 52425 Jülich, Germany
E-mail: y.arinicheva@fz-juelich.de*

Considering long half-lives and high radiotoxicity of minor actinides such as Am, Cm and Np, their long-term safe disposal presents a major challenge. Monazite ceramics meet essential criteria for potential nuclear waste forms for the conditioning of minor actinides since these materials exhibit pronounced stability (chemical, thermal and radiolytic) and high waste loading [1]. While crystal structure and chemical durability of La,GdPO₄-system were studied [2], systematic investigations on other lanthanides phosphates solid solution series are scarce in literature to date. For a reliable assessment of their long-term behaviour under disposal conditions deeper fundamental studies on phosphates with monazite structure are necessary.

This work focuses on the thermal and mechanical properties of lanthanum phosphates with monazite structure with partially or fully exchanging lanthanum by europium – an inactive surrogate for the minor actinides. Physical properties such as microhardness and fracture toughness are important for the characterisation of the quality of compact materials and play an essential role regarding the long-term stability of radionuclide containing pellets for nuclear disposal. These properties influence the dissolution behaviour, since increasing of reactive surface occurs by mechanical destruction of the material, and help to describe and to understand crack formation due to swelling processes caused by He-evolution from α -decay reaction.

La_(1-x)Eu_xPO₄ (x = 0 – 1) powder samples were synthesized over wet chemical methods: precipitation and microwave assisted hydrothermal method. According to XRD data pure single phase solid solutions after hot pressing at 1350°C and 50 MPa with a sintering density of more than 98% of the theoretical density were obtained for all compositions. Results of XRD and Raman analysis point to ideal solid solution formation. The crystallization of the (La,Eu)PO₄ powders was investigated by a combination of TG-DSC and XRD showing a phase transition from rhabdophane to monazite structure between 700 °C and 800 °C in dependence of the Eu-content. Significant differences in microstructure and therefore in mechanical properties were observed by applying of various synthesis methods. The mechanical properties (microhardness and fracture toughness) of the pellets depend linearly on the europium content. This behaviour can be described as an analogue of Vegard's law for the mechanical properties.

[1] G.R. Lumpkin, Elements 2006, 2, 365 – 372.

[2] O.Terra, N. Clavier, N. Dacheux, R. Podor, New J. Chem., 2003, 27, 957–967

**EFFECT OF IRRADIATION ON THE PARAMETERS OF GAS
EVOLUTION DURING THERMOLYSIS OF 30% SOLUTIONS OF
TRIBUTYLPHOSPHATE**

E.V. Belova, Z.V. Dzhivanova, A.V. Rodin, B.F. Myasoedov

IPCE RAS, Moscow

The modern technology of reprocessing spent nuclear fuel of power plants is based on the Purex process, which uses a solution of TBP as an extractant. Aliphatic hydrocarbons with straight chain and mixtures thereof (dodecane, a mixture of n-paraffins), and mixtures of iso-paraffins (tetrapropylene) or a mixture of n-paraffins, iso-paraffins and naphthenes (dearomatised kerosene) are often used as hydrocarbon diluents in radiochemical industry. Among chlorinated solvents the carbon tetrachloride was used as diluent, there is also information on the use of hexachlorobutadiene in a cycle of fractionation HLW.

High radiation and chemical exposure lead to the formation and accumulation of degradation products in the extractant, which could negative affect its hydrodynamics and selectivity. Therefore the extractant is constantly regenerated in an extraction cycle by soda washing, however, a part of the degradation products is not removed by this treatment and gradually accumulates therein. Products of radiochemical decomposition of hydrocarbon diluents play the main role in these phenomena among which the main products are nitration, oxidation, and mixed products of interaction with TBP.

Radiation and thermal behavior of the extractant was studied in relation of diluents: n-dodecane, straight chain light diluent C-13 and naphthenic - RJ-3.

The obtained data indicate that the diluent RJ-3 in mixtures with nitric acid is less stable than the diluent C-13, below the onset temperature of exothermic process which occur more rapidly with evolution of larger amount of gaseous products. This is confirmed by the appearance of condensed reaction products of diluents with nitric acid. The mixtures of 30% solutions of TBP in diluents RJ-3 and C-13 with 12 M nitric acid show the similar thermal stability, though in first case the conversion of extractant RJ-3 is much deeper than diluent C-13.

**THERMAL STABILITY OF THE TWO-PHASE MIXTURES OF
RADIATION-DEGRADED TRIBUTYLPHOSPHATE IN PARAFFINIC
HYDROCARBONS WITH NITRIC ACID IN ISOCHORIC
CONDITIONS**

E.V. Belova¹⁾, A.V. Rodin¹⁾, E.R. Nazin²⁾, B.F. Myasoedov¹⁾

¹⁾ – *IPCE RAS, Moscow*

²⁾ – *SECNRS, Moscow*

Reprocessing of spent nuclear fuel is based on the extraction separation of components from nitric acid solutions. Currently, as the most commonly used extractant is solution of tributylphosphate (TBP) in a paraffinic hydrocarbon diluent. In this system in contact with nitric acid may occur runaway exothermic reactions leading to a significant self-heating, release of large quantities of gaseous products and eventually to a possible rupturing of devices. Conditions of wrong removal of gaseous products may change the mechanism of oxidation leading to a sharp increase of oxidation rate due to autocatalytic reactions and significantly reduce a heat loss from the zone of chemical reaction by cooling through evaporation. Extractant exposed to significant radiation during operation and products of degradation may also negatively affect on thermal stability in contact with nitric acid.

We study the influence of different production factors that affect on the TBP solution in paraffinic hydrocarbons and the thermal stability in the isochoric conditions. Such factors are an exposure to high doses of ionizing radiation, high temperatures for a long time and high concentrations of oxidizing component. For comparative evaluation of different types of extractant treatments the following characteristics were selected: the starting temperature of exothermic processes (T_{onset}), the rate of rising temperature due to the exothermic reaction, the rate of gas release and the specific volume of the gaseous products of thermal explosion. As paraffinic hydrocarbons n-dodecane, and diluent C-13 were investigated.

Based on our experiments, we can draw the following conclusions:

1) Products with higher reactivity toward nitric acid are formed by heating TBP solutions in n-dodecane and C-13 with nitric acid, irradiation alone or in combination with heat-degradation;

2) TBP solution shows the lower value of the self-heating, the maximum pressure and the rate of the oxidation processes, than systems without solvent;

3) The products of degradation extractant are oxidized by nitric acid with production of heat and gases at temperatures lower than the oxidation of "fresh" extractant;

4) The main heat and gas releasing is due to the reaction TBP with nitric acid at temperatures above 100 °C. But the interaction of oxidant with degradation products may heat the system to these temperatures and produce the active form of the oxidant, thus being the initiator of runaway reaction.

Thus, some of the conditions of radiolysis and thermolysis of extractant adversely affect on the thermal stability of the product's mixtures with nitric acid, especially in the two-phase systems, and heating of these mixtures is more dangerous for the occurrence of runaway reaction in comparison with fresh mixture.

THERMOCHEMICAL TRANSFORMATIONS OF U-234 AND U-238 ISOTOPES IN BRITHOLITE

R.V. Bogdanov, M.I. Skriplev

Saint-Petersburg State University, Radiochemistry Department, 199034, Russia, Saint-Petersburg, University quay 7-9, bogdanov@rb7584.spb.edu

The storage of nuclear high-level radioactive waste (NHLW) in an underground repository involves a release of high energy and thus a substantial heating of radioactive blocks. In this work, chemical processes have been studied in the temperature range of 100° – 900 °C, occurring in britholite which is considered to be a natural analogue of multiphase silicate-phosphate NHLW matrices. To provide information on red-ox processes in the mineral, two Uranium isotopes, ^{238}U and ^{234}U , which are present in the natural minerals as two species at least: U(IV) and U(VI), have been used as probes.

Samples of the mineral of 20-50 mg were heated in a vacuum for 10 minutes at 100 °C and up to 900 °C, by increments of 50 °C. The relative content and isotopic composition of the U(IV) and U(VI) fractions were determined by methods of radiochemical analysis and alpha-spectrometry. In the course of isochronic annealing, several stages of red-ox processes were revealed occurring in different temperature ranges. In the range below 300 °C, U(VI) reduction prevails, whereas in the 300-550 °C range it is oxidation of U(IV). Based on X-ray diffraction data, it is concluded that the observed thermochemical transmutations of Uranium isotopes occur in the metamict structure of britholite, affecting only the electronic subsystem of the mineral. It is the electronic- and hole traps of different depths that act as red-ox agents, in particular, the hole centers which are localized on the Ce (IV) atoms. From the temperature of 600 °C, a new stage of reduction is onset which is supposed to be related to a recrystallization of the metamict structure of britholite.

A different thermochemical behavior have been revealed of ^{234}U and ^{238}U isotopes. On heating to 300 °C, the relative content of the U (IV) fraction increases from 35% to 45%. Simultaneously, a decrease is observed of the $^{234}\text{U}/^{238}\text{U}$ isotopic ratio in the U(IV) fraction, from 1.3 to 1.2, as a result of selective oxidation of the ^{234}U (IV) atoms and their transition to the U(VI) fraction: the $^{234}\text{U}/^{238}\text{U}$ ratio in this fraction grows up from 0.87 to 0.92. In the authors' opinion, no similarity in ^{234}U and ^{238}U behaviour can be explained by a difference in the nearest environment of these Uranium isotopes.

**THE MOBILE COMPLEX ON PURIFICATION
OF LIQUID RADIOACTIVE WASTE**

N.G. Firsin¹⁾, S.N. Florya²⁾, A.I. Kostylev¹⁾, I.S. Ledovskoy¹⁾, A.V. Naumov³⁾

¹⁾ – *Khlopin Radium Institute, 194021 Russia, St. Petersburg, 2nd Avenue Murinsky, 28, nfirsin@khlopin.ru*

²⁾ – *RosRAO, 119017 Russia, Moscow, Bolshaya Ordynka, 24/26, info@rosrao.ru*

³⁾ – *Kirov-Chepetsk branch of the Volga Territorial District RosRAO, 613040 Russia, Kirov region, Kirov-Chepetsk, Kirov Street, 16, papihgin.prto@mail.ru*

The report presents the results of work to clean up low-level radioactive water accumulated in the former radiochemical plant, now a radiochemical control laboratory Kirov-Chepetskiy branch of the Volga Territorial District RosRAO, on a mobile installation specially created for this.

Radioactivity is determined by the uranium isotopes in general, there are strontium-90 and cesium-137 also. There is quite a lot of nitrate - ions in the initial water. Mobile complex reduces nitrates and radioisotopes to health standards with a capacity no less than 700 liters/hour. The degree of reduction of waste is not less than 40. The system is designed to work around the clock in fully automatic mode or in single unit by unit mode control. The installation can be ruled by a single operator.

The mobile complex created in Khlopin Radium Institute based on a standard 40-foot container. The container divided into three parts: the operating – room, the main technological section and the unit cementation of waste. Three installations are situated at the main technological section: the installation of ultrafiltration, 3-stage reverse osmosis unit and a vacuum evaporator. In the fourth block concentrate suspensions after ultrafiltration and saline concentrate from vacuum evaporator are mixed and cemented in 200 liter steel drums for disposal.

THE WAYS OF TECHNETIUM LOCALIZATION AT THE SNF REPROCESSING

**N.D. Goletsky, B.Ya. Zilberman, A.S. Kudinov, S.A. Rodionov,
D.V. Ryabkov, Yu.S. Fedorov**

*FSUE RPA "V.G. Khlopin Radium Institute",
194021, S.-Petersburg, 2-nd Murinskiy prospect, 28, goletsky@khlopin.ru*

Tc behavior in the steps of NPP SNF reprocessing with the use of solvent extraction has been investigated traditionally at the RPA «V.G. Khlopin Radium Institute». Several variants of Tc withdrawal into the products of the 1st extraction cycle are possible depending on the assigned task. In the RT-1 and Experimental Demonstration Center (EDC) flowsheets Tc is stripped in combination with Pu and Np following with its separation during Pu purification by extraction and/or precipitation [1]. In the UP-2&3 flowsheet Tc is selectively backwashed by 80-85% before Pu stripping. In this respect the different variants of Tc output by more than 98% into any flow of the 1st cycle has been tested at the KRI extraction rigs using the simulated and real SNF solutions in the centrifugal contactors and mixer-settlers.

Technetium withdrawal to the raffinate could be achieved in the extraction process with two-zone scrubbing of the solvent product of actinides and Tc by rising the flowrate of the highly acid scrub which leads to necessary rise of acidity in the raffinate [2]. The trials were carried out in mixer settlers with the use of the «warm» VVER-1000 simulate solution and full-scale SNF simulate solutions of AMB VVER and mixture.

Tc backwashing together with Zr was demonstrated in the course of testing the flowsheet where the extraction and scrubbing sections were totally separated, converting the scrubbing step to Zr and Tc joint withdrawal at the HNO₃ concentration about 4 mol/L. [3]. It lead to the increased backwash flow rate violating the balance of tritiated acidic and water balance.

The best option seems to be the Tc stripping in the barrier section after Pu and Np stripping by the «soft» reductant (aceto-hydroxamic acid (AHA) without hydrazine) where it remained in the U solvent product. The effect of Tc stripping is achieved by the use of U(+4) and N₂H₄ mixture in the presence of the AHA. The process was successfully tested in the centrifugal contactors; however it is proposed to test the process in mixer settlers because of the absence of aeration and possibility to install the electrochemical cell.

The high decontamination from Tc ($D_f > 10^3$) of Pu & Np and U products allowed to exclude extraction and/or precipitation steps for element purification using the direct thermochemical denitration of the evaporated backwashes; by this way the complicated ILW treatment is excluded as well from the reprocessing flowsheet. The elaborated method can be effectively combined with the selective Np(V) stripping before Pu reductive stripping (Superporex process) [4].

[1] Fedorov Yu.S., Zilberman B.Ya., Aloy A.S., etc. *Rus. Chem. J*, 2010, v.54, № 4, p. 12-24.

[2] Kudinov A.S., Goletsky N.D., Zilberman B.Ya., etc. *Atomic Energy*, 2013, v. 114, № 5, p. 246-259.

[3] Anisimov O.P., Aloy A.S., Zilberman B.Ya., etc. *VI Intern. Nucl. Forum (St. Petersburg, 26-30.09.2011). Papers. CICE&T. SPb. 2011. p. 180-190.*

[4] Zilberman B.Ya., Fedorov Yu.S., Mishin E.N et al. *Proc. Intern. Conf. Global'2003 (USA). ANS, 2003. p. 503 - 507.*

TECHNOLOGY OF PLASMA TREATMENT OF SOLID RADIOACTIVE WASTE

V.A. Gorbunov, M.A. Polkanov, F.A. Lifanov

FSUE "Radon"

*2/14, 7th Rostovskiy lane, Moscow, Russian Federation, 119141,
val_gorbunov@rambler.ru*

The technology of deep thermal treatment of solid radioactive waste (SRW) using plasma sources of heat has been developed and implemented at SIA "Radon". This technology allows to obtain in one step the product, suitable for placement at the site of long-term storage or disposal without using any additional methods for waste processing and conditioning. The developed plasma technology has several advantages over the conventional methods of solid waste incineration, in particular:

- there is no required total preliminary sorting and separation of radioactive waste arriving to plasma treatment;
- the high value of the volume reduction factor of radwaste treated;
- conversion of waste into the safest and most compact form (slag compound), having high chemical durability to aggressive influences;
- the improved environmental safety of the process due to reduced volume of the technological gases emissions into the atmosphere and content of the harmful substances in them;
- the possibility of treatment of the mixed types of waste with relatively high content of non-combustible compounds and moisture;
- relatively low specific investment and operating costs per unit of mass of treated waste.

In result of the researches carried out at the SIA "Radon" the full-scale plant "Pluton" has been designed and put into operation in 2007, destined for plasma-pyrolytic treatment of low and intermediate level solid radioactive waste by throughput 200÷250 kg/h.

The plasma method permits to treat, in contrast to the incineration technologies, both combustible waste, and non-combustible components (debris, glass, soil, metal scrap, insulation materials, etc.) as well. The specific activity of the γ , β -emitting radionuclides in waste is limited to the values of 3.7×10^6 Bq/kg and 2.2×10^5 Bq/kg for α -emitting isotopes.

The development works carried out in the period from 2007 to 2012 have resulted in the extended morphology of radioactive waste treated by the plasma method due to wastes with high moisture content - soil, ion exchange resins, spent ion-selective sorbents, and berries. The total humidity of radioactive waste ranged from 15 to 40 wt. %, reaching 90 % in some packages. The total share of non-combustible components in SRW achieved 40 wt. %.

The implementation of plasma treatment of solid radioactive waste is technically and economically advantageous because it can replace expensive facilities for managing SRW based on technologies of its incineration, cementation, compaction and super-compaction of waste. The products of the plasma waste treating will not require re-conditioning in 30-50 years.

Currently SIA "Radon", together with several research and design centers of Russia participates in realization of projects to create plasma facilities for plasma treatment of radioactive wastes in Russia.

BIODEGRADATION OF CEMENT MATRIX DURING LONG-TERM STORAGE OF RADIOACTIVE WASTE

O.A. Gorbunova

*FSUE "RADON", 7th Rostovsky lane 2/14, Moscow, Russia
olg-gorbunova@yandex.ru*

Microorganisms develop in cement compounds with low and intermediate level radioactive waste (RW) during their long-term storage, which use components of liquid and solid RW as a nutrition media – nitrates, organic liquids, cellulose-containing materials, plastic and rubber.

Microorganisms existence has been determined during geoecological monitoring and experimental drilling of near-surface storage facilities for cemented RW after 40-50 years of their exploitation. These are anaerobic and facultative anaerobic bacteria with fermentation and denitrification metabolism type related to the following species: *Alcaligenes*, *Bacillus*, *Pseudomonas*, *Rhodococcus*, *Flavobacterium*, *Micrococcus*, *Mycobacterium*, *Arthrobacter*.

Presence of microorganisms and biogenic destruction of cement matrix were confirmed on basic of physical-chemical, microstructure, and microbiological investigations during 10 years of field trials with cement compounds with RW under the conditions of near-surface storage facilities. With the help of spectrometry was determined concentration of aggressive substances which appear as a result of microorganism metabolism in a cement matrix with RW. With the help of scanning electron microscopy, X-ray phase and petrographic analysis was established the mechanisms of biodegradation of cement matrix. Biogenic organic acids, N₂, CO₂ destruct the microstructure of the cement matrix because of pores and cracks formation. Reaction of acid metabolites with hydrated cement minerals leads to appearance of soluble calcium salts. Because of that the immobilizing properties of cement matrix such as durability and radionuclides fixation become worse.

In order to prevent biogenic destruction and increase the quality of a cement matrix the type and concentration of biocide additives compatible with cement grout were experimentally selected. The "historical" near-surface storage facilities with RW have been sealed with the help of highly-penetrating cement grout with biocide additive. The new technologies and compositions for RW cementation have been developed taking into account potential biogenic destruction.

HIGH-SILICA ADDITIVES DURING CEMENTATION OF RADIOACTIVE WASTE

O.A. Gorbunova^{1,2)}, S.E. Vinokurov²⁾

¹⁾ – FSUE “RADON”, 2/14, 7th Rostovsky lane, Moscow, Russia

²⁾ – Vernadsky Institute of Geochemistry and Analytical Chemistry Russian academy of sciences, 19, Kosygin str., Moscow, Russia,
olg-gorbunova@yandex.ru

The new composition has been developed for solidification of liquid radioactive waste (LRW). The composition includes Portland cement and 5-10 wt.% of natural mineral additive such as high-silica natural materials (diatomite, silica flour, biosilica) with silica content of at least 80 wt.%.

These sorbing natural mineral additives not only increase the reliability of radionuclides fixation and strength of cement matrix. It has been established that terms of cement matrix setting decrease significantly when these given sorbing, natural, mineral additives are used during cementation of boron-containing LRW.

Table. Influence of high-silica natural materials on properties of cement compounds based on boron-containing LRW (water-to-cement ratio W/C=0.6)

Type of additive (10 % of cement weight)	Terms of setting	Compression strength, MPa/day				Leaching rate of ¹³⁷ Cs on 14 -28 day, $\times 10^{-3}$, g/(cm ² ·day)
		7	28	56	0.5 year	
Without additive	14-20 day	-	11.2	40.8	27.5	3.1-2.5
Bentonite (for comparison)	14-20 day	-	10.5	15.4	16.0	2.0-1.8
Silica flow	5-8 hour	9.1	10.1	29.6	18.4	1.8-0.6
Biosilica	3-5 hour	17.8	19.2	31.0	17.3	1.7-1.0
Diatomite	3-5 hour	13.5	15.0	28.4	18.8	0.6-0.2

Boron-containing LRW originates at nuclear power plants (NPPs) with water-cooled power reactors and contains significant amounts of oxygen boron substances (boron acid, borates) which are responsible for low pH level. Acid boron-containing LRW can be hardly solidificated with the help of alkaline cement grout. Setting and hardening of such cement matrixes occurs no earlier than in 14-56 days. Lime is used for prior neutralization of boron-containing LRW and the volume of solidificated waste increases in 1.5-3 times. Suggested additives allow to decrease setting and hardening time without prior neutralization and volume increase as well as to achieve high strength of matrix and reliable fixation of radionuclides.

The work has been implemented within Federal Special Purpose Program (FSPP) «Cadry» Cov. № 14.132.21.1737 from 01.10.2012.

**REPRO – THE FIRST RADIOACTIVE EXPERIMENT AT ONKALO
UNDERGROUND FACILITY**

**K. Helariutta¹⁾, J. Ikonen¹⁾, M. Siitari-Kauppi¹⁾, M. Voutilainen¹⁾,
P. Andersson²⁾, J. Byegård²⁾, K. Nilsson²⁾, M. Skålberg²⁾, A. Poteri³⁾,
P. Kekäläinen⁴⁾, J. Timonen⁴⁾, K. Kemppainen⁵⁾, I. Aaltonen⁵⁾, L. Koskinen⁵⁾**

¹⁾ – *Department of Chemistry, P.O.B. 55, 00014 University of Helsinki,
Finland*

²⁾ – *Geosigma AB, P.O.B. 894, 75108 Uppsala, Sweden*

³⁾ – *VTT, P.O.B. 1000, 02044 VTT, Finland*

⁴⁾ – *Department of Physics, P.O.B. 35, 40014 University of Jyväskylä, Finland*
⁵⁾ *Posiva oy, Olkiluoto, 27160 Eurajoki, Finland*

Spent nuclear fuel from TVO's (Teollisuuden Voima Oy) and Fortum's nuclear power plants is planned to be disposed of in Olkiluoto (Eurajoki, Finland) bedrock repository at a depth of more than 400 meters, packed in copper canisters. The safe final disposal of nuclear waste in bedrock requires information of the radionuclide transport within the porous and water-containing rock matrix, in case the multiple release barrier system of nuclear fuel, steel-filled copper canister and bentonite filling around the canister fails in the passage of millennia. Due to this, the physical and chemical transport and retention properties of rock matrix need to be studied.

Due to sorption and matrix diffusion radionuclides migrate at much lower speed than the velocity of the flowing water. Influence of the rock matrix on the retention can be characterised by porosity of the rock matrix and solute diffusivity in the rock matrix. In the performance assessment conditions most of the retention takes place in the vicinity of the deposition holes. In-situ diffusion experiments are able to provide data on the rock matrix retention properties that is relevant for the repository near field conditions.

The first in-situ experiment with radioactive materials within ONKALO underground rock characterisation facility in Olkiluoto was performed during the spring and summer of 2012. The experiment is part of REPRO (experiments to investigate rock matrix Retention PROperties) experimental campaign that is realised as a collaboration between universities, VTT and private sector companies. In this experiment, an artificial flow channel was built along a drill hole at depth of 420 m to study the matrix diffusion of selected radionuclides in water phase. A mixture of HTO, ²²Na, ³⁶Cl and ¹²⁵I was injected in 20 µl/min water flow and their passage through the flow channel was observed both with an online gamma detector and by taking samples. The experiment was completed in about 5 months when the injected activities were practically completely collected from the flow channel. As a result, breakthrough curves, i.e. the activities of the radionuclides in outflow as a function of time were obtained. These results will provide data for modelling and are utilised to demonstrate that assumptions applied in the safety case are in line with the site evidence.

**BIOGEOCHEMICAL BARRIER CONCEPT IN CONSERVATION OF
RW SURFACE STORAGEES**

V.A. Ilin, V.E. Tregubova, A.V. Safonov, E.V. Zakharova

*Frumkin Institute of Physical chemistry and Electrochemistry
Russian academy of sciences, 31, Leninsky prospect, Moscow, Russia
alexey safonov@gmail.com*

Radioactive wastes accumulated during XX century in open pond-storagees of nuclear fuel cycle enterprises represent a great danger for the environment and require development of modern engineering systems aimed for safe conservation for long time period. One of such methods is implemented projects of conservation the Karachay lake on PA "MAYAK" and OJSC "SCC" ponds. Now effective geological and geochemical barrier systems using natural and artificial isolation materials are developed. However, heterogeneous chemical and radioisotopic composition of radioactive wastes imposes a number of restrictions at usage of many materials because of different migration properties of RW components. Thus, for example, heptad pertechnetate anion has high migration ability. Nitrate ions as the main components in RW composition (concentration up to 300 g/l) have the same properties.

The idea of this work consists of development of antimigration barrier of new generation, that includes chemical and biological components. Role of the latter can be carried by underground microorganisms that are able to immobilize radionuclides in several ways. It is known that the most possible mechanisms managing technetium transfer are microbiological reduction, accompanied with biosorption or bioaccumulation; chemical interaction with one of biologically produced reductant – sulfide ion, accompanied with the formation of slightly soluble and readily sorbed chemical form of technetium- technetium sulfide, and sorbtion of pertechnetate with sulfide ion on sulfide minerals. In this work we have carried out the search of microorganisms that are able to lead to metal reduction, sulfide formation (sulfate reduction) and denitrification. Microorganisms of Shevanella, Desulfovibrio and Pseudomonas genera have been chosen and studied.

This work is supported by, RFBR project № 12-08-3127412, and federal programme «Kadry» № 2012-1.2.1-12-000-2007-9066.

**SUBLIMATION PURIFICATION OF ^{99}Mo PREPARATION
BY LASER TREATMENT OF THE REACTION CELL INTERNAL
COATING**

I.A. Istomin, V.P. Medvedev

***OTI NIYAU MEPhI, Pobeda str., 48, Ozyorsk, Chelyabinsk Region,
E-mail: VPMedvedev@mephi.ru***

Activities were aimed at impurity removal out of ^{99}Mo preparation by laser beam exposure of the carrier inert surface with molybdenum salt applied on it resulted in selective evaporation of pure molybdenum.

The process is based on the laser beam capability to create local controlled high-temperature influence on a surface within a short time period (several seconds). During this time molybdenum salt is sublimated into gaseous phase with its simultaneous removal into a cooled vessel (cooler). At the same time the total volume of the cell is not heated resulting in purification time reduction, which is especially important in case of short-lived radionuclides.

At the industrial scale a traditional scheme is being applied to produce Mo preparation. The process includes Mo generation in reactor, chemical processing of the target, Mo sorption or extraction concentration and its sublimation purification. Specific stages could be extended with additional operations, but the sequence in total remains unchanged.

The advantage of the mentioned scheme is a large experience of its application at the industrial scale. The disadvantage of the method is a great number of operations and low product yield because of the extended process.

In the current work we suggest to decrease significantly the duration of Mo purification process, increasing thereby the preparation yield, due to laser treatment of the surface with molybdenum salt applied on it in a thin layer. Specific temperature range on the carrier surface will correspond to the specific energy range of the laser facility. Varying laser facility energy according to pre-proven scheme, one or another blend element could be sublimated highly accurate.

Experimental activities were carried out at Laser Center Ltd. in S.Peterburg. Silicon carbide carriers were manufactured at FSUE NII NPO LUCH in Podolsk city and delivered for experiments to the Laser Center.

Data derived from experiments with the laser facility Minimarker-2 in the Laser Center Ltd. demonstrated that molybdenum and related substances selectively moved on the cooler surface due to laser exposure. Laser beam energy range with maximum Mo yield made 15% to 25% of the maximum energy of the laser facility. Practically all impurities could be removed out of Mo preparation within 5 minutes. Further investigations have been planned to derive energy limits of Mo and impurity yields.

So, the investigations resulted not only in demonstration of principal possibility of instantaneous sublimation and de-sublimation of molybdenum and related substances, but valuable relations between efficiency of these processes and laser radiation energy were determined as well.

RADIATION INDUCED DISSOLUTION OF SPENT NUCLEAR FUEL

M. Jonsson

*School of Chemical Science and Engineering, Applied Physical Chemistry,
KTH Royal Institute of Technology, SE – 100 44 Stockholm, Sweden,
matsj@kth.se*

One of the key issues in the safety assessment of a future geological repository for spent nuclear fuel is the rate of fuel dissolution in the event of groundwater intrusion. This is assumed to be governed by the dissolution of the fuel matrix UO_2 . Under normal groundwater conditions at the depth of a deep repository, the solubility of UO_2 is very low and the fuel matrix is assumed to act as a barrier. However, the inherent radioactivity of the fuel itself will cause radiolysis of the groundwater (in the event of canister failure) producing highly reactive radicals and molecular species. These species will alter the conditions significantly. The mechanism and kinetics of oxidative dissolution of UO_2 have been studied in detail for several decades. The rate of oxidative dissolution depends on the dose rate which is directly related to the specific activity of the spent nuclear fuel. More recently, the inhibiting effect of H_2 has been studied and can now be considered to be fairly well understood. A relatively simple model describing the rate of spent nuclear fuel dissolution under various conditions including the influence of H_2 and matrix composition will be presented. Furthermore, the influence of other groundwater components and materials present in the vicinity of the spent nuclear fuel are explored.

ADVANCED SEPARATION TECHNIQUES FOR RADIONICKEL

M. Kaipiainen, R. Koivula

University of Helsinki, A.I. Virtasenaukio 1, P.O.Box 55, 00014 University
Helsinki, Finland, maria.kaipiainen@helsinki.fi

The nuclear power plant produces large volume of radioactive waste waters. One of these are decontamination solutions that typically contains large amount of inactive metal ions (K^+ , Na^+ , Fe^{3+} , Ca^{2+}) and only trace amount of radioactive metals, usually locked in some complexing agents such as oxalate. For reduction of negative impact on the environment it is needed to find efficient separation technique of these radionuclides.

The aim of this work was to develop advanced separation technique for removal of radionickel. The technique is based on degradation of formed metal complexing agents like EDTA and adsorption of released metal on to the ion exchanger. The synergy of photocatalytic activity of an inorganic ion exchanger and $UV/O_3/H_2O_2$ has been seen as a possibility to find a specific method of separating radionickel. Some metal oxides are used as ion exchanger and the oxidative destruction of nickel complexes is studied with this inorganic material as photocatalytic semiconductor under UV light irradiation.

Preliminary results using SnO_2 and UV light irradiation resulted in high cobalt uptake from Co-EDTA containing solution.

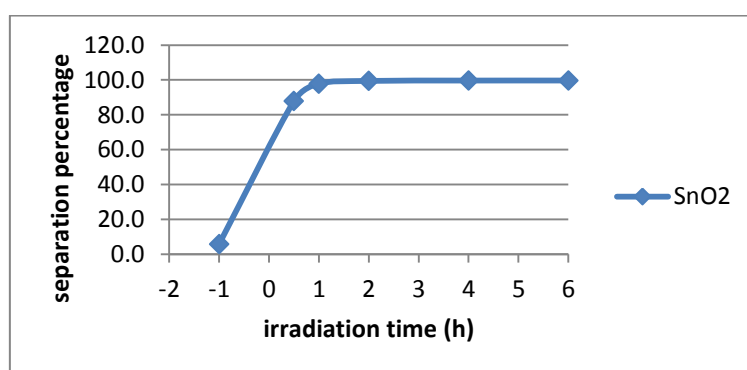

Fig. 1. Separation of Co from 10 μM Co-EDTA 10 mM $NaNO_3$ solution by SnO_2 and UV irradiation at pH 6. At zero point UV irradiation is started and -1 means one hour of mixing absent of any irradiation.

The experiment work is going on and future results will be presented on symposium.

**“STATION NUCLEAR FUEL CYCLE BALANCE MODEL”
SOFTWARE PACKAGE**

**V.A. Kashcheev, T.V. Podymova, O.V. Shmidt, V.A. Tkachenko,
S.G. Tretyakova**

***JSC VNIINM (Bochvar Institute), 123098 Rogova St., 5a, Moscow, Russia,
djilyn@yandex.com***

One of the variants of nuclear fuel cycle closing is spent nuclear fuel (SNF) treatment and nuclear fuel (NF) fabrication near nuclear station, i.e. station nuclear fuel cycle (SNFC). Complexity of the SNF treatment processes and practical absence of ready-to-use technological and technical solutions for the SNFS development (especially for innovative processes) requires great developmental work including calculation and comparison of economical, ecological and safety criteria for different variants of SNFC flowsheets. Providing calculations manually is very time-consuming routine work. Process computer simulation reduces work difficulty and decreases duration of calculations and quantity of possible mistakes in routine calculations.

By this time “SNFC balance model” software package for the SNFC flowsheet balance calculations has being developed in JSC VNIINM. The software package includes user interface and SNF treatment processes mathematical models database. The software package allows construction of block-structured balance computer model, where each block contains mathematical description of separate operations input flows conversion into output flows. Blocks sequence and interconnections pattern between them are to be selected from existing file or defined through user interface.

The models database is expanded by adding new blocks or editing existing ones in accordance with recent R&D data received. At the moment the models database contains more than 100 operations related with SNF and nuclear waste treatment. In near future the models database is planned to be integrated to the software package possessing advanced functionality in comparison with the “SNFC balance model”. The models database as well is to be extended with new models of operations and apparatus taking into account physico-chemical aspects and operating conditions of processes, equipment properties etc.

At the time development of detailed multiparametric models is carried out simultaneously with the “SNFC balance model” software improving, mean user interface optimization and extension and editing the models database. Some examples of user interface are given and ways of model database and software package future development are formulated in the paper.

**THE USE OF ROCK CASTING CONTAINERS FOR STORAGE OF
GLASS WASTE PRODUCTS**

**V.B. Krapukhin, V.V. Kulemin, E.P. Krasavina, V.A. Lavrikov,
S.A. Kulyukhin**

*Frumkin' Institute of Physical Chemistry and Electrochemistry, Russian
Academy of Science, Leninskii prospekt, 31, 119071 Moscow, Russia,
E-mail: kulemin@ipc.rssi*

Formation and accumulation of a significant amount of radioactive wastes with various radionuclide composition and a level of specific activity keeps now a urgency of a problem of their storage and a burial place and assumes creation of various ways of their processing and manufacturing of new kinds of the equipment and installations. One of the promising areas, which are regarded by many experts as a major for high-level waste - is vitrification. Glass waste products should be placed in containers, which meet to the certain requirements. One of perspective materials for manufacturing containers is the stone casting possessing radiating and corrosion stability, water resistance, property to not collapse under influence of temperature 400-500°C, good ability to formation. Products from stone casting have high strength characteristics, are resistant to corrosion. However, when vitrified radioactive waste placed in stonecast containers, the internal thermal stress or stress due to different forms of glass block and the inner cavity of the container take place. To eliminate these disadvantages is proposed to conduct lining the inside of the container by mineral wool. This work also considers the question of cover joining to the container and the construction of a pilot plant for welding the cover to the container.

SPIRAL FILTERING ELEMENT AS THE BASIS OF THE FILTRATION INSTALLATIONS FOR REMOVAL OF THE SOLID RADIOACTIVE IMPURITIES FROM GAS AND LIQUID PHASES

V.B. Krapukhin, V.V. Kulemin, V.A. Lavrikov, S.A. Kulyukhin

*Frumkin' Institute of Physical Chemistry and Electrochemistry, Russian
Academy of Science, Leninskii prospekt, 31, 119071 Moscow, Russia,
E-mail: krapukhin@gmail.com*

It is known, that the filtering materials after carrying out of some cycles «filtration - regeneration» is irreversible stopped up by the firm phase and should be taken from devices and replaced. We developed the new spiral filtering element (SFE). Main advantages of SFE are high reclaiming qualities in comparison with standard filtering.

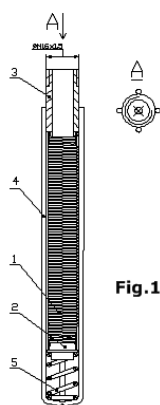
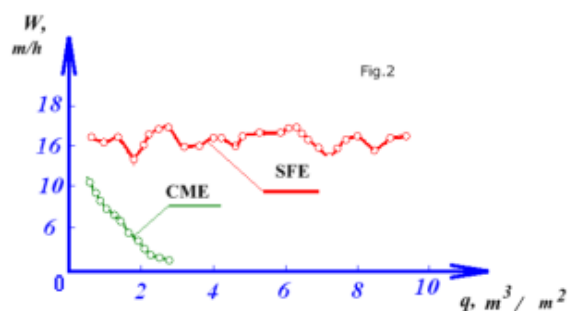

Fig.1

The general view of SFE is shown on fig. 1. It consists of a filtering partition 1, a cover 2, the union 3, a skeleton 4 and spring 5. The filtering surface 1 is carried out by the corrosion-proof wire with a diameter from 0,6 up to 0,8 mm and represents a screw cylindrical spiral between of its coils with the special image carried out the filtering backlashes: their size can be from 7 up to 300 micron; diameter of a filtering partition - 16 mm; its length - up to 370 mm. From one end the filtering partition closes by cover 2, and from another - has the union 3 with external groove M16x1,5. The coaxiality of coils 1 is provided with a skeleton 4. Sixty SFE make 1 m² of a filtering surface. Dimensional diameter and length SFE make according to 25 mm and 415 mm. SFE are established vertically by unions upwards or downwards.

To convince the advantages of SFE before other filtering materials, the comparative tests of SFE filtering properties and ceramic-metal element (CME) have been carried out. Results of tests are shown on fig. 2. Each point on the schedule is the average result on one cycle of filtering, and the subsequent result is received after carrying out of regeneration of the filter by a return stream of a liquid. Apparently from dependence of speed of filtering (W) from specific loading (q), i.e. from the volume of the filtered liquid related to unit of the



filtering surface, speed of CME filtering continuously falls, while at speed of SFE filtering remains practically to a constant and does not depend on number of the filtration and regeneration cycles. We repeatedly received a similar ratio, when the comparison with other filtering materials and elements, at filtering various liquid and gas environments was carried out.

CLEARING OF THE LOW RADIOACTIVE LIQUID WASTE FROM OILS AND OIL PRODUCTS BY UV-RADIATION AT THE NUCLEAR POWER PLANT

V.V. Kulemin, V.B. Krapukhin, V.A. Lavrikov, S.A. Kulyukhin

Frumkin' Institute of Physical Chemistry and Electrochemistry, Russian Academy of Science, Leninskii prospekt, 31, 119071 Moscow, Russia, E-mail: kulemin@ipc.rssi

The basic methods of concentration and purification of liquid radioactive waste on the nuclear power plant are distillation and ionic exchange. During vaporization of oil waste products and the fulfilled washing solutions the part of mineral oil passes in a condensate. Clearing of such condensate on ion-exchanged filters results to oiling of ion-exchanged materials and to decrease number of filter cycles. At more often regeneration of ion-exchanged filters additional volumes of waste products as the fulfilled reclaiming solutions, washing and loosening waters are formed.

Usually a condensate of oil clear on coal filters or on the filters loaded by copolymers of styrene and divinylbenzene. However, such clearing is insufficiently effective and frequently does not provide the requirements established for waste waters. The attention of authors was involved with methods of clearing of water environments from the organic substances, based on deep oxidizing transformations of hydrocarbons into carbonic gas and water. From processes of oxidation of hydrocarbons up to CO₂ and H₂O, sold at moderate conditions, our attention has involved photochemical oxidation with the help of UV-radiation. An irradiation carried out by a mercury lamp (capacity of a lamp 220 Wt). In water and modeling solutions before an irradiation added mineral oil. Modeling solutions simulated the trap waters. Modeling solutions, besides mineral oils, contained, g/dm³: 0.166 NaNO₃, 0.074 Na₂SO₄, 1.576 H₃BO₃, 1.295 KNO₃, 1.0 NH₃. For check of the data received on simulators, experiments have been carried out on waste water from a tank of pure condensate, the pump of decontaminated water, and also a tank of trap waters of the Kalinin NPP. Besides mineral oil trap waters contained ¹³⁴Cs – 4.18·10⁵, ¹³⁷Cs – 6.85·10⁵, ⁵⁴Mn – 23.94·10², ¹³¹I – 4.07·10⁴, ⁶⁰Co – 7.92·10³, ²⁴Na – 12.32·10³ Bk/dm³, Fe – 1.2 mg/dm³, Na -3.0, K – 0.27, H₃BO₃ – 2.2 g/dm³, pH - from 9 up to 12. Density of a solution was 1.007 g/cm³. Water from pump of decontaminated water and a tank of pure condensate supervised only on the contents of mineral oil.

It was showed that the rate of clearing can be increase with increase of temperature. It is note that the contribution of the secondary «darkness reactions» was significant. Presence of inorganic impurity reduces the rate of clearing in comparison with an irradiation of a water-oil mixture.

SORPTION OF ^{60}Co MICROQUANTITIES ON LAYERED DOUBLE HYDROXIDES FROM AQUEOUS SOLUTIONS

S.A. Kulyukhin, E.P. Krasavina, I.A. Rumer

*Frumkin' Institute of Physical Chemistry and Electrochemistry, Russian Academy of Science, Leninskii prospekt, 31, 119071 Moscow, Russia,
E-mail: kulyukhin@ipc.rssi.ru*

The development of the nuclear power industry resulting in the accumulation of large amounts of radioactive waste including liquid waste has been urging the development of new express methods of liquid radioactive waste (LRW) reprocessing that would allow LRW handling without its long-term prestorage. This requires developing methods of separation of highly toxic radionuclides including ^{60}Co for their subsequent concentration and burial. One of the methods that has been widely used for separating radionuclides in the ionic state is sorption.

This work studies sorption of ^{60}Co microquantities from aqueous solutions of varied compositions on layered double hydroxides (LDH) of the composition $\text{M}_3^{2+}\text{M}^{3+}(\text{OH})_6(\text{A}^n)_{1/n}\text{mH}_2\text{O}$, where $\text{M}^{2+} = \text{Mg, Zn, or Ni}$; $\text{M}^{3+} = \text{Al, Fe, and Nd}$; $\text{A}^n = \text{CO}_3^{2-}, \text{Cl}^-, \text{SO}_4^{2-}, \text{EDTA}^{4-}, \text{NO}_3^-, \text{OH}^-, \text{or } \text{C}_2\text{O}_4^{2-}$, as well as on layered double oxide (LDO) of Mg and Al.

The research study has found that ^{60}Co sorption on LDH-Mg-Al-Cl, LDH-Mg-Al- NO_3 , LDH-Zn-Fe- CO_3 , LDH-Ni-Fe- CO_3 , and LDH-Mg-Nd- CO_3 from 10^{-15} - 10^{-9} mol/l aqueous solutions of $\text{Co}(\text{NO}_3)_2$ and on LDO-Mg-Al from 10^{-3} - 10^{-5} mol/l aqueous solutions of $\text{Co}(\text{NO}_3)_2$ is poor. At a liquid-solid phase contact time of 24 h and $V/m = 50$ ml/g, the distribution coefficients (K_d) for ^{60}Co are $\sim 10^2$ - 10^3 ml/g.

On the other hand, ^{60}Co displays good sorption on LDH-Mg-Al- CO_3 , CLDH-Mg-Al- SO_4 , LDH-Mg-Al-EDTA, LDH-Mg-Al- C_2O_4 , LDH-Zn-Al- CO_3 , LDH-Ni-Al- CO_3 , LDH-Mg-Fe- CO_3 , and LDH-Mg-Nd- CO_3 from aqueous nitrate solutions. The K_d values for ^{60}Co for the above-mentioned compounds are as high as 10^4 - 10^5 ml/g at a liquid-solid phase contact time of 24 h and $V/m = 50$ ml/g in the $\text{Co}(\text{NO}_3)_2$ concentration range 10^{-15} - 10^{-9} mol/l.

A study of ^{60}Co desorption from LDH-Mg(^{60}Co)-Nd- CO_3 in 0.05-0.2 mol/l solutions of Na_2CO_3 , NaNO_3 , $(\text{NH}_4)_2\text{C}_2\text{O}_4$, and $\text{Na}_2\text{H}_2\text{EDTA}$ and distilled water has found that the highest desorption ability is characteristic of $\text{Na}_2\text{H}_2\text{EDTA}$. After 15-min contact of LDH-Mg(^{60}Co)-Nd- CO_3 with 0.1 and 0.05 mol/l solutions of $\text{Na}_2\text{H}_2\text{EDTA}$, the desorption efficiency for ^{60}Co is $\sim 100\%$ and $\sim 99\%$, respectively.

The research findings allow us to suggest that LDH-Mg-Al- CO_3 , LDH-Mg-Al- SO_4 , LDH-Mg-Al-EDTA, LDH-Mg-Al- C_2O_4 , LDH-Zn-Al- CO_3 , LDH-Ni-Al- CO_3 , LDH-Mg-Fe- CO_3 , and LDH-Mg-Nd- CO_3 may be used for separating ^{60}Co radionuclide, as well as U(VI) and also Sr and Y radionuclides (as analogs of trivalent f-elements) from aqueous solutions in various technological processes.

CONVERSION OF I₂ IN IONIC FORMS ON THE COMPOSITE MATERIALS "FIZKHIMIN"TM IN WATER COOLANT AT NUCLEAR POWER PLANTS

S.A. Kulyukhin, L.V. Mizina, I.A. Rumer

*Frumkin' Institute of Physical Chemistry and Electrochemistry, Russian Academy of Science, Leninskii prospekt, 31, 119071 Moscow, Russia,
E-mail: kulyukhin@ipc.rssi.ru*

We studied the sorption of CH₃¹³¹I and I₂ on an AV-18 ion-exchange resin from the water coolant which takes places on the some of the Russian WWER-type NPPs. It was found that the AV-18 anion-exchange resin can absorbs I₂ and CH₃¹³¹I from the solution. After 2 h of contact between liquid and solid phases, I₂ absorption was about 70%, whereas the CH₃¹³¹I absorption was only about 30.0%. Anion-exchange resin AV-18 effectively absorbs I₂ (more than 99%) from this water coolant of a WWER-type NPP only after 24 h of contact between the liquid phase and the resin. In this case the distribution factors K_d for I₂ were higher than 10³ cm³/g, whereas the distribution factors K_d for CH₃¹³¹I were lower than 200 cm³/g.

Because of a low rate of sorption of I₂ and CH₃I the anion-exchanged resin AV-18 could not effectively and quickly localize these forms of radioactive iodine from the water coolant. These findings made it apparent that a new more effective material to absorb molecular and organic iodine from water solutions was required, and it was desirable to employ materials used in working NPPs to coolant decontamination.

In our experiments, we used ion-exchange resin KU-2, which we modified to obtain sorptive materials. The materials IPCE-C1 and IPCE-C2 with about 8.0 and 5.5 wt.% of Cu), and also IPCE-CS with about 10.1 wt.% of Cu and Ag were obtained and used for our bath experiments. For these materials, we studied sorption of different forms of radioactive iodine (¹³¹I, ¹³¹IO₃⁻, CH₃¹³¹I) and I₂ from water coolant which takes places on the some of the Russian WWER-type NPPs.

Preliminary experiments showed that the non-modified cation-exchange resin KU-2 has a low sorption capacity for CH₃¹³¹I and I₂ in the studied solution: the distribution factors are not higher than 5.0 cm³/g at V/m = 100. At the same time under similar experimental conditions the distribution factors K_d for I₂ for all developed materials are higher than 10³ cm³/g. The distribution factors K_d for ionic forms change from 20.0 to 150 cm³/g, whereas for the organic form, they are not more than 11.0 cm³/g.

As follows from the data on I₂ sorption kinetics on our developed materials and anion-exchanged resin AV-18, during 15 min of contact between the solid and liquid phase practically full I₂ absorption (more than 99.0%) takes place on the modified resin KU-2 vs. 50% on the resin AV-18. As above-mentioned, the 99% absorption of I₂ on anion-exchange resin AV-18 can be achieved only after 24 h. Unfortunately, the developed materials have low efficiency for CH₃¹³¹I in the studied solutions.

So, our findings allow us to conclude that using a combination of our developed materials and anion-exchanged resins such as AV-18 would allow to more effectively decontaminate the water coolant from ionic and molecular forms of radioactive iodine and partially organic form in working and new developed NPPs.

**MATRIX DIFFUSION OF RADIONUCLIDES ON A DRILL CORE
SAMPLE FROM ONKALO, OLKILUOTO**

**J. Kuva¹⁾, M. Voutilainen²⁾, P. Hölttä²⁾, P. Kekäläinen¹⁾, J. Timonen¹⁾,
M. Siitari-Kauppi²⁾, K. Hänninen²⁾, J. Häkkinen²⁾, K. Helariutta²⁾,
L. Koskinen³⁾**

¹⁾ - *University of Jyväskylä, Department of Physics, P. O. Box 35, 40014
University of Jyväskylä, Finland, jukka.kuva@jyu.fi*

²⁾ - *University of Helsinki, Department of Chemistry, P. O. Box 55, 00014
University of Helsinki, Finland, ma.voutilainen@helsinki.fi*

³⁾ - *Posiva Oy, Olkiluoto, 27160 Eurajoki, Finland, lasse.koskinen@posiva.fi*

Diffusion of radionuclides into rock matrix is an important factor in safety analysis of nuclear waste deposition in Finland. It is one of the major retarding factors if the radionuclides make it past man made barriers into the bedrock. For some elements sorption is also important and helps to retard the radionuclides even more. Matrix diffusion is being measured *in-situ* in ONKALO, Olkiluoto. In order to determine parameters for the *in-situ* measurements, and to validate transport models under well controlled conditions, parallel laboratory experiments were conducted.

To this end, measurement setup was constructed, where a steady flow of Olkiluoto groundwater simulant was induced in a 1.25 mm thick flow channel around an 80 cm long drill core sample. A short pulse of tracer was then injected into the flow and the measured breakthrough curve was fitted by a mathematical model for an infinitely deep matrix which takes into account, in addition to matrix diffusion, longitudinal diffusion and Taylor dispersion in the flow channel [1]. This setup, which was similar to that of the *in-situ* experiments, was planned to depict a scenario where radionuclides are being transported in a water conducting fracture in the bedrock.

The experiment was tested twice with colored tracers, potassium permanganate and uranine to see if the flow is even around the sample. First run was done with I-125 as a tracer with a 50 µl/min flow speed and then with HTO, Na-22 and Cl-36 as tracers with a 20 µl/min flow speed. The retarding effect of matrix diffusion was observed in the breakthrough curves.

[1] P. Kekäläinen, M. Voutilainen, A. Poteri, P. Hölttä, A. Hautojärvi and J. Timonen (2011) "Solutions to and validation of matrix-diffusion models." *Transport Porous Med.* 87: 125-149

URANIUM SPECIATION IN VITRIFIED INCINERATOR SLAGS

G.A. Malinina¹⁾, S.V. Stefanovsky^{1,2)}

1) - FSUE "Radon", 7th Rostovskii lane 2/14, Moscow 119121 Russia, malinini@yandex.ru

2) - Frumkin Institute of Physical Chemistry and Electrochemistry RAS, Leninskii av. 31, Moscow 119071 Russia, profstef@mtu-net.ru

Radioactive waste incinerator slag surrogate with a target composition of (wt.%) 6.0 Na₂O; 9.0 K₂O; 15.0 CaO; 15.0 Al₂O₃; 10.0 FeO; 30.0 SiO₂; 10.0 P₂O₅; 5.0 U₃O₈ and its mixtures with either Na₂B₄O₇ or Na₂Si₂O₅ at weight ratios 85:15 and 75:25 were melted at 1400 °C and 1500 °C, respectively, and slowly cooled in a turned-off furnace. The melted slag is composed of nano-sized crystals of Na/Al-substituted nagelschmidite Na_{1.10}K_{1.21}Ca_{2.65}Al_{1.56}Fe_{0.45}P_{1.96}Si_{2.01}U_{0.05}O_{15.86} (Ng), Na-Ca uranate (U), nepheline Na_{0.39}K_{0.40}Ca_{0.18}U_{0.04}Al_{0.67}Fe_{0.30}Si_{0.92}P_{0.10}O_{4.20} (Ne), UO₂-based solid solution (O), and hematite (H) or high-Fe spinel (S) distributed in the Ca/Al silicate vitreous phase (V). Addition of Na₂B₄O₇ increases fraction of vitreous phase and relative amount of crystalline phases changes in favor of Fe/Al-spinel and UO₂-based solid solution whereas addition of Na₂Si₂O₅ did not markedly changed phase composition of the samples (Fig. 1). SEM/EDX confirms XRD data and shows U partitioning between vitreous phase, nagelschmidite, and UO₂-based solid solution (Fig. 2).

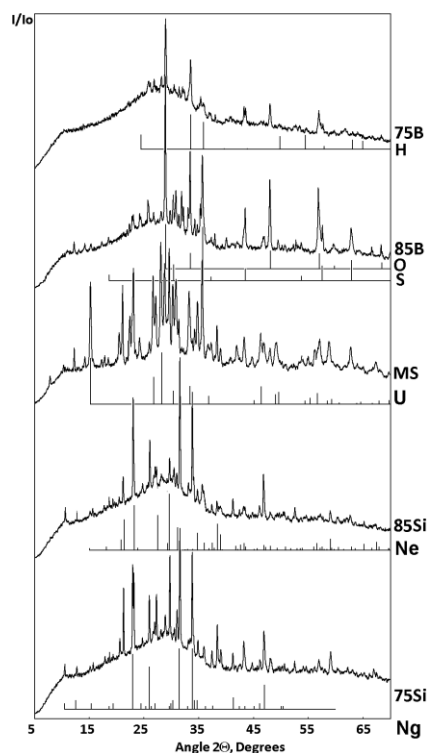

Fig. 1. XRD patterns of the samples and standards.

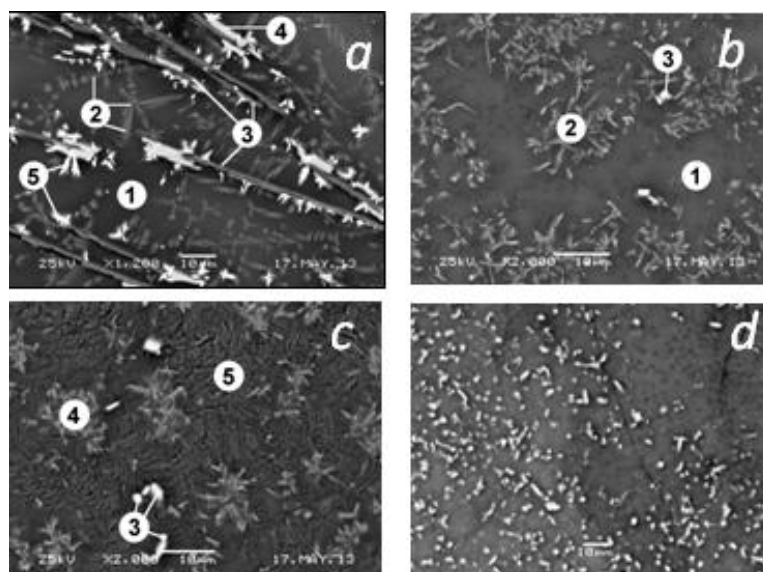

Fig. 2. SEM images of the samples 75:25 with Na₂B₄O₇ (a) and Na₂Si₂O₅ flux (b,c) and melted slag (d).

a: 1 – V, 2 – Ng, 3 – Hz, 4 – Hm, 5 – UO; b,c: 1 – V, 2 – Ne, 3 – Sp, 4 – U+Ng, 5 – Ne; d: U, O, Ng in V+Ne matrix.

Infrared, Raman, XAFS and leachability studies are in progress.

**THE URANIUM DECONTAMINATION FACTORS FOR SOME
RADIONUCLIDES DURING SNF REPROCESSING AT THE
RADIOCHEMICAL FACTORY OF FSUE "PA "MAYAK"**

A.B. Melentev¹⁾, A.N. Mashkin¹⁾, K.E. German²⁾

¹⁾ – *FSUE "PA "Mayak", Ozersk, Russia, cpl@po-mayak.ru*

²⁾ – *IPSE RAS, Moscow, Russia, guerman_k@mail.ru*

The FSUE «PO«Mayak» radiochemical factory (the RT-1 facility) provides reprocessing of the spent nuclear fuel (SNF) and the regeneration of the SNF fissionable material. The two cycle Purex-type process is used for the extraction, purification and separation of uranium and plutonium. Part of the reprocessed uranium is directed to the re-enrichment process. To meet the strict requirements for material purity in that process a research was carried out to determine the U decontamination factors (DF) from fission and radiation decay products, of which most important are ²²⁸Th, ⁹⁹Tc, ¹⁰⁶Ru. U DF's were also studied for ¹³⁷Cs, ¹²⁵Sb, ^{234m}Pa and some others.

During the production of a batch of uranyl nitrate of specified quality samples of technological and ready U products were taken and analyzed with ICP MS and gamma-spectral analysis. It was determined, that the U/²²⁸Th DF for the 1st extraction cycle may exceed 500, which is enough for producing U product of sufficient quality. On the 2nd extraction cycle the flow of previously reprocessed U is added to the U from the 1st extraction cycle, thus bringing in new portion of ²²⁸Th, accumulated in the product during the storage time due to decay of ²³²U. The U/²²⁸Th DF for the 2nd cycle is smaller, than on the 1st one (30 to 70 depending on the mode of operation), but still is significant enough to produce purified U with only trace amounts of ²²⁸Th. Due to that only the logistics define the quality of the final uranyl nitrate, as ²²⁸Th accumulates in the product during holdout time.

The U/Tc DF was found to be 340-450 on the 1st extraction cycle, and one of the smallest compared to the similar parameters for other fission products (for comparison, the U/¹³⁷Cs Df is about 10⁷). The U/Tc DF for the 2nd extraction cycle is also small because of the absence of heavy reducing environment, and lays within the limits of 5 to 10. Under the stable working conditions of the whole extraction process such DF provide the quality of the final uranium product, matching the strict demands of the ASTM C 787-03 standard (the Tc content should not exceed 0.5 mkg/g U). But in some cases of unwanted oxidation processes on the first extraction cycle, the decrease in the uranium content in the solvent phase, or other technological problems, the U/Tc DF may fall to 2-3, leading to the inappropriate Tc quantities in the U on the 2nd cycle. The U/¹⁰⁶Ru decontamination factor on the 1st extraction cycle is 2,5·10³ and on the 2nd cycle is ~120. With the very large content of ¹⁰⁶Ru in the SNF solutions directed to reprocessing, and the complexity of Ru chemistry, even with such DF's the activity of ¹⁰⁶Ru in the ready U products may be significant (between 10² and 10³ Bk/g U).

With the study of the obtained results some proposals were made for the increase of U DF's - the preventive withdrawal of Tc to the 1st cycle raffinate, efficient stabilization of the stage of reductive separation of Pu, and new solvent washing conditions for the 2nd extraction cycle.

**BEHAVIOR OF $^{137}\text{Cs}^{131}\text{I}$ AND $^{137}\text{CsOH}$ RADIOAEROSOLS IN THE
ELECTROSTATIC FIELD**

**N.B. Mikheev¹⁾, V.V. Kulemin¹⁾, V.A. Lavrikov¹⁾, I.V. Melikhov²⁾,
I.A. Rumer¹⁾, S.A. Kulyukhin¹⁾**

*¹⁾ - Frumkin' Institute of Physical Chemistry and Electrochemistry, Russian Academy of Science, Leninskii prospekt, 31, 119071 Moscow, Russia,
E-mail: kulemin@ipc.rssi*

²⁾ – Lomonosov' Moscow State University, Vorobjovi gori, 119992 Moscow, Russia

The problem of extraction and localization of volatile radioactive nuclides and from a gas phase has got special importance in connection with failures of a various degree of the danger, periodically arising on the enterprises of the nuclear industry. In a case of accidents on the nuclear power plant, accompanying with destruction of active zone of reactor, a big quantity of radioactive aerosols formed in the atmosphere of a protective shell of a reactor. Studying properties of radioactive aerosols for a prediction of their behavior, and also clearing of the gas streams allocated at failure from them of therefore is necessary.

In this study the behavior of radioactive aerosols formed during condensation of super saturated steam of $^{137}\text{Cs}^{131}\text{I}$ and/or $^{137}\text{CsOH}$ at the presence of an electrostatic field is investigated. Radioaerosols of $^{137}\text{Cs}^{131}\text{I}$ and/or $^{137}\text{CsOH}$ were formed as a result of evaporation of crystals of salts from a metal surface, heating up to high temperatures due to resistor. It is shown, that imposing of additional potential on the generator of aerosols can be operated behavior of formed aerosols $^{137}\text{Cs}^{131}\text{I}$, $^{137}\text{CsOH}$ or their mixes in an electrostatic field.

NITRIC ACID ADDUCTS FORMATION DURING BARIUM AND STRONTIUM NITRATES CRISTALLIZATION FROM NITRIC ACID MEDIA AND THEIR COPRECIPITATION

N.E. Mishina, B.Ya. Zilberman, A.A. Lumpov, T.I. Koltsova, D.V. Ryabkov

Khlopin Radium Institute, 2nd Murinsky av., 28, 194021, Saint-Petersburg, Russia, e-mail: mishinan@khlopin.ru

Ba(NO₃)₂ precipitation is one of the limiting factors during HLW evaporation and so needs the method of prediction. In this respect the model was proposed in our previous work [1] for approximation of the Ba(NO₃)₂ and Sr(NO₃)₂ solubility in HNO₃ solutions using the law of mass action. As a result the two linear areas were identified according to slope of the solubility on total nitrate ion concentration in logarithmic scale and the existence of the adducts, containing 1-2 molecules HNO₃ molecules with Ba(NO₃)₂ and 2 ones with Sr(NO₃)₂ were suggested. The question is the proposed precipitation is only formal, or it carries a certain chemical sense.

The presence of nitrate complexation in Ba(Sr)(NO₃)₂ - Me(NO₃)_x systems is confirmed by formation of the slightly soluble double salt Ba(NO₃)₂·2KNO₃, as well as by the shape of the solubility curve for Ba(NO₃)₂ and Sr(NO₃)₂ in solutions of ammonium and sodium or RE nitrates, characterized by the minimum and further solubility increasing.

The chemical analysis using ¹³⁷Cs or Be(NO₃)₂ as a reference mark in the case of Ba(NO₃)₂ or Sr(NO₃)₂, respectively, was carried out to confirm the hypothesis of the nitric acid adduct formation. The volume of mother liquor captured by the precipitate was determined for further calculation of the total HNO₃ and nitrate ion amounts contained in the precipitate (the capture of Ba could be ignored). The amount of excess NO₃⁻-ion was compared with the excess of H⁺-ion and then both were related to metal amount in the precipitate. It was found out that Ba(NO₃)₂ and Sr(NO₃)₂ precipitates in the range from 0 to 5 mol/L HNO₃ contained only small permanent amount of excess, occluded by precipitate. With increasing HNO₃ concentration in the liquor upper 7 mol/L HNO₃ a sharp increase of acid content in barium and strontium nitrate precipitates was observed, indicating on the complex compound formation. In the same area co-crystallization of Ba and Sr nitrates took place.

IR spectra confirm the presence of nitric acid and/or water in precipitated barium and strontium nitrates and in their solid solutions precipitated at the high acidity or obtained by re-crystallization during their mixing in wet form.

According to X-ray diffraction patterns and chemical analysis of co-crystallized barium and strontium nitrates the formation of solid solution (Ba,Sr)(NO₃)₂ was also detected, the composition of this solid solutions varies depending on a method of precipitates preparation, the concentration of nitric acid and the Ba to Sr ratio in the liquor.

So, the formation of adducts of barium and strontium nitrates with nitric acid was qualitatively confirmed by several methods because of their metastable nature.

[1] N.E. Mishina, A.A. Akhmatov, B.Ya. Zilberman, et al. Radiochemistry, 2010, Vol. 52, Iss. 5, pp 523-529.

CERAMIC WASTE FORMS FOR THE CONDITIONING OF MINOR ACTINIDES

**S. Neumeier, A.A. Bukaemskiy, F. Brandt, S. Finkeldei, Y. Arinicheva,
G. Modolo, D. Bosbach**

*Forschungszentrum Jülich GmbH, IEK-6, Nuclear Waste Management,
Wilhelm-Johnen-Str., 52425 Jülich, Germany
E-mail: s.neumeier@fz-juelich.de*

The disposal of high level radioactive waste is one of the most pressing and demanding challenges. With respect to long-term safety aspects of geological disposal, the minor actinides (MA) such as Am, Cm and Np and long-lived fission products such as ^{35}Cl , ^{135}Cs , ^{79}Se , ^{90}Sr and ^{129}I may be of particular concern due to their long half-lives, their high radiotoxicity and mobility in a repository system, respectively. Ceramic waste forms for the immobilisation of these radionuclides have been investigated extensively in the last decades since they seem to exhibit certain advantages compared to other waste forms (incl. borosilicate glasses and spent fuel) such as high loadings and chemical durability. Currently, most on-going nuclear waste management strategies do not include ceramic waste forms. However, it is still important to study this option, e.g. with respect to specific waste streams and certain constraints regarding deep geological disposal.

In the present communication we report on the research program in Jülich regarding ceramic waste forms for the conditioning of MA. It is based on fundamental science and follows an integral approach that covers the separation of elements or elemental groups with similar chemical properties from a waste stream by liquid/liquid extraction as well as the immobilisation in ceramic materials as hosts. The research focuses on single phase ceramics such as Monazites and Zirconates with Pyrochlore structure and includes:

1.) Development and optimisation of synthesis routes suitable for immobilisation of MA into ceramic waste forms and the handling of radionuclides such as sol-gel route, hydrothermal synthesis and co-precipitation,

2.) structural and microstructural characterisation using state of the art spectroscopic (Raman, TRLS, EXAFS), diffraction (powder and single crystal XRD) [3] and microscopic (SEM, FIB/TEM) techniques,

3.) determination of thermodynamic data (calorimetry) and reactivity under conditions relevant to geological disposal, in particular with respect to leaching/corrosion in aqueous environments (static & dynamic dissolution experiments on powders and pellets) as well as

4.) studies on radiation damages (irradiation with α -particles and/or heavy ions, and incorporation of short-lived actinides such as ^{238}Pu , ^{241}Am or ^{244}Cm).

Finally, a fundamental understanding of the long-term behaviour on the atomic scale will help to improve the scientific basis for the safety case of deep geological disposal concepts using ceramic materials.

IMMOBILISATION OF RADIOACTIVE OILS WITH THE USE OF THERMALLY EXPANDED GRAPHITE

A.V. Nikitin, I.A. Shestakov, Ya.V. Sergeecheva, E.A. Tyupina, A.B. Sazonov

D. Mendeleev University of Chemical Technology of Russia, 9th Miusskaya sq., Moscow, 125047, Russia, nikitin_89@mail.ru

Thermally expanded graphite (TEG) may be used for solidification of radioactive waste oils for their long-time storage. Such oils are usually contaminated with different radionuclides; tritium and cesium isotopes have the greatest diffusion mobility among them. The experiments have been performed to study the sorption ability of TEG with respect to oils and the rate of tritium and ^{137}Cs leaching from the cement matrix containing TEG and oil.

TEG was prepared by consecutive treatment of exfoliated graphite with aqueous CrO_3 and H_2SO_4 . Graphite bisulphate was hydrolyzed and dry oxidized graphite was rapidly heated up to 900-1000 °C. Bulk density of the produced TEG occurred to be 0.01-0.015 g/cm³ depending on the origin of initial graphite. It was found that optimal size of graphite particles is between 100 and 200 µm. In this case TEG absorbs oil up to 20 ml/g retaining powder-like.

Tritium and ^{137}Cs contaminated oils (real wastes) were used in the experiments. Activities of tritiated samples were measured by liquid scintillation counting technique with *Hidex 300 SL*. Activities of ^{137}Cs were measured with NaI(Tl)-based γ -spectrometer.

Cement compounds containing 30% (volume) of oils were prepared in cylindrical forms by stirring cement paste with TEG-oil powder. Water/cement ratio equal to 0.35 was found to be optimal for compounds contained no additives. Different additives to cement paste (CaCl_2 , $\text{Na}_2\text{O}\cdot n\text{SiO}_2$, bentonite, *Melflux*, *Nordplast*, etc.) were tested as well. Before the experiments all the cement blocks were kept in humid atmosphere during 28 days for maturity.

The studies of leaching show quite low tritium mobility at room temperature (24±1 °C). The time dependence of leaching degree can be described by the formula $S(t) = A \cdot t^B$ where A and B are the coefficients. The B values are a little lower than 0.5 meaning that diffusion mode of tritium release takes place but the diffusion slows down in time. Evaluated diffusion coefficients have an order of 10^{-13} m²/s. Most of the additives slightly increase leaching rates.

In the case of ^{137}Cs the majority of leaching kinetic curves can be approximated by almost square-root dependence. The diffusion coefficient values vary from $1.8 \cdot 10^{-14}$ to $4 \cdot 10^{-13}$ m²/s. The best result was obtained with an additive of bentonite (7%).

After 90 day contact of the compounds with water the leaching degree for both radionuclides approaches to 10-25%, however no oil spill on water surface was observed. This means that tritiated water or water-soluble organic substances are being leached from the compounds and ^{137}Cs releases from the compounds into water as an ion.

It is shown that chemical and mechanical properties of the compounds satisfy the requirements for solidified radioactive wastes. The compounds are found to be stable to radiation and the leaching rate decreases after exposition of the samples to ^{60}Co γ -rays. Thus TEG should be considered as the promising material for incorporating radioactive waste oils into the cement matrix.

**STUDYING THE EFFICIENCY OF THE REAGENT PROCESSING IN
COMBINATION WITH FRACTIONATING FOR DECONTAMINATION
OF SOILS**

V.B. Nikolaevskiy, N.V. Klochkova, S.S. Batusov

***FSUE «RADON», 119121, 7oj Rostovskij per., d. 2/14 Moscow, Russia,
Zelentchev@mail.ru***

Due to the urgency of the problem of rehabilitation of contaminated sites and to reduce the volume of radioactive waste for long-term storage, are developed and tested soil decontamination technology using physical and chemical methods for disposal of radioactive contamination. Method of fractionation based on the removal of fine soil, most contaminated fraction can decontaminate soil with only a low content of radionuclides due to the low purification factor of 5. For more thorough cleaning of soils in the Federal State Unitary Enterprise "RADON" the technology of their decontamination reagent, it is based on a specially selected soil treatment agent solution, followed by concentration of contamination from process fluid. Both methods can be used independently or jointly.

This paper presents the results of research to improve the effectiveness of cleaning soil contaminated with Cs-137, the application of chemical treatment in combination with fractionation. The dependence of the degree of purification of the different soil parameters: concentration of the selected reactant, temperature and duration of the process. The optimum values of these parameters were found. Raising the temperature of the process chemical treatment to 160⁰C using pressure leaching can increase the degree of purification of soil up to 99%.

It is shown that the removal of fines by hydroseparation leads to an additional reduction in the average 3 times radionuclide content in the soil. When cleaning the ground under a combined scheme, combining the reagent processing and fractionation produced purified sand fraction (90%) and dirty, which is represented by fine-grained (less than 0.16 mm) fraction of the soil and radioactive concentrate isolated from the leach solution the precipitation or sorption method.

The combination of chemical treatment at selected conditions gidroseparatsionnym removal of fines to reduce the level of contamination the soil 200 times. The volume of radioactive waste can be reduced to 2 - 8 times, depending on the ratio of sand and fines in the soil.

The implementation of the combined soil decontamination technology will significantly improve the performance of his treatment and give opportunity its application in a higher level of radioactive contamination of soils.

INFLUENCE OF INTERACTION TIME OF Cs¹³⁷, Sr⁹⁰ AND Co⁶⁰ WITH BACKFILL MATERIALS ON FORMS OF THESE ELEMENTS

E.E. Ostashkina¹⁾, O.A. Burlaka¹⁾, G.A. Varlakova²⁾

¹⁾ – Federal State Unitary Enterprise "Radon", 119121 Moscow, Russia, the 7-th Rostovsky Lane, 2/14

²⁾ – Joint Stock Company "A.A.Bochvar High-technological Research Institute of Inorganic Materials", 123098, Moscow, Russia, the Rogov Str, 5a

Nature barrier materials are very important structure elements of backfill for near surface repositories for radioactive wastes. They retain radionuclide migration from repositories and their expansion into the biosphere. These backfill materials must be cheap and easy for getting, these are such as sands, excavated rocks and their mixtures.

The radionuclide migration depends on sorption properties of backfill materials. Properties of backfill materials determine the forms of stored radionuclide, especially in long-time contact between them. Physicochemical forms of radionuclides penetrated into nature barrier materials change in time [1].

This paper presents evaluation of Cs¹³⁷, Sr⁹⁰ and Co⁶⁰ forms and their redistribution in barrier materials in time.

The experiments were carried on with covering silt and sand. The covering silt contained quartz, feldspar and clay minerals (kaolinite group, illite, vermiculite, montmorillonite). The sand of glaciolacustrine origin contained quartz and small amounts of clay minerals, feldspar, ferrum hydroxides and manganese compounds [2-4]. In the experiments, the samples of above mentioned materials were in contact with radionuclides solutions during 2 weeks, 1, 2, 4 and 6 months accordingly. After these they were treated by solutions of different compositions [1, 5].

The experiments showed that Cs¹³⁷, Sr⁹⁰ and Co⁶⁰ were in different forms and proportions in tested materials. Redistribution of these forms can be observed in time. The main feature for all radionuclide was the decreasing of ratio of mobile forms during their contact with materials increase. Simultaneously increased tightly bound forms of radionuclides. The time of transformations processes in the materials differed, which could be connected with mechanism of radionuclide absorption by the solid phase.

The time of transformation of radionuclide forms increases in such way in line Sr < Co < Cs and in line sand < covering silt. A great part of cesium ran to tightly bound form in a first weeks of contact. The ratio of cesium in tightly bound form achieved its maximum (95 %) already after two weeks of contact. Strontium and cobalt compared to cesium were more mobile and their transformation into tightly bound form occurred gradually during the experiment. The maximal abundance of these radionuclides in tightly bound form was 68–71 % and 74–85 % respectively.

The results of experiments allowed to estimate hardness of radionuclide fixation by barrier materials for near surface repositories and to conclude that radionuclide migration in backfill increases in operational period.

[1] F.I. Pavlotskaya (1979). "Forms and migration of radionuclides of human origin in soil." Moscow Atomizdat: 215 p.

[2] S.A. Dmitriev, A.S. Barinov, G.A. Varlakova et al.(2005) "Distribution and migration of radionuclides in host rock surrounding a shallow ground of vitrified radioactive waste". Migration'05 Avignon, France: P. 201.

[3] A.S. Barinov, G.A. Varlakova, I.V.Startceva, Z.I.Golubeva, O.A.Burlaka. (2006) "Radionuclide distribution in backfill ground of experimental repository for vitrified radioactive waste" Radiochemistry-2006, Dubna: pp. 289-290.

[4] G.A. Varlakova, Z.I. Golubeva, S.V. Roschagina et.al. (2009) "Development of backfill mixtures for near surface repository for radioactive waste" Radiochemistry-2009, Moscow: pp. 253-254.

[5] F.I. Pavlotskaya, A.P. Novicov, T.A Goryachenkova et.al. (1998). Radiochemistry, 40, 5: pp. 462-467.

**SOLIDIFICATION OF NON-TECHNOLOGICAL WASTE WITH
POLYMERS USAGE AT RADIUM INSTITUTE**

Yu. Pokhitonov¹⁾, V. Babain¹⁾, M. Alyapyshev¹⁾, D. Kelley²⁾

¹⁾ - V.G. Khlopin Radium Institute, St. Petersburg, Russia, ypokh@khlopin.ru

²⁾ - Pacific Nuclear Solutions, Indianapolis, USA, pwtusa@aol.com

In the run of scientific and production activities in Radium Institute there are generated the LRW of the most various compositions, which are partially processed (with the use of cementation technology) as accumulated and removed to the special-purpose enterprise ("Radon") for a long-term storage.

The process of cementation has wide enough practical application including the use for a long time at Radium Institute for solidification of aqueous solutions.

At the same time, solidification of some waste (water-organic) also runs into a number of serious difficulties due to organic liquid and cement incompatibility.

It should also be mentioned that the solutions of such compositions (thanks to organic liquids, first of all) do not meet the needed requirements and cannot be transferred there for further processing and long-term storing. In addition, processing of such solutions in laboratory space is associated with a great number of technical and financial problems.

Just because of this fact, there was proposed the idea to use polymer materials for solidification of Radium Institute's LRW directly at the site that will make it possible to give up in future the procedures of waste storage and transportation in liquid form.

The paper illustrates results of the various experiments that include aqueous waste stream solidification examples, and volume reduction test data that will determine cost benefits to the waste generators.

It was shown in all cases the polymers can be effectively applied to LLW and ILW aqueous and organic waste.

According results obtained we also can mentioned another possible application of polymers namely to use the polymers in cases of origination and elimination of accidental conditions, when it is necessary to reduce concentration of radioactive aerosols in air and prevent their spread in the environment.

ELECTROCHEMICAL DEPOSITION OF ACTINIDES FROM ORGANIC EXTRACTS CONTAINING DIPHENYL(DIBUTYL)-CARBAMOYLMETHYLPHOSPHINE OXIDE AND IONIC LIQUIDS

G.A. Pribylova¹⁾, I.V. Smirnov²⁾, A.P. Novikov¹⁾

- ¹⁾ - *Vernadsky Institute of Geochemistry and Analytical Chemistry, Russian Academy of Sciences. Kosygin Str., 19, 119991 Moscow, Russia, e-mail: pribylova_galina@mail.ru*
- ²⁾ - *Khlopin Radium Institute, 2nd Murinskii Ave., 28, 194021 St.Petersburg, Russia*

A method of electrochemical deposition for uranium, plutonium, and americium from an organic medium was developed. The method can be used in various industries, including processing of irradiated nuclear fuel (INF), production of isotopic sources of actinides or radiation heat sources, as well as environmental radiation monitoring by alpha-spectrometric determination of actinide content.

Process steps:

1. Liquid natural or technological samples were evaporated to a volume of 1-100 ml and acidified with nitric acid to 2-8 mol/l. Then actinides were extracted with 1-10 ml of 0.001-0.1 mol/l and 0.001-0.1 mol/l Ph₂Bu₂ (diphenyl(dibutyl)carbamoymethylphosphine oxide) solution in 1,2-dichloroethane (DCE).

2. Solid samples (1-10 g) preliminary dried, homogenized, and calcinated in a muffle at 500°C were twice treated with 50 ml of 8 M nitric acid at boiling for 1 h. Solutions were separated from a residual solid and combined. Then liquid-liquid extraction of actinides was carried out similarly to item 1.

3. Solid samples of INF (0.1-2.0 g) were grinded to 0.01-0.03 mm particles and treated with the same organic solution till complete solubilization (solvate extraction).

4. To an organic solution of actinides and complexing agents in DCE obtained as described above, N,N-dimethylformamide and PPF₆ were added up to 50-300 ml and 1-10 mol/l, respectively. Electrodeposition of actinides was performed in a Teflon cell with a platinum wire anode and a cathode in the form of a circular target made from stainless steel, having a diameter of 30-40 mm, under ambient temperature and cathodic current density equal to 0.02-0.1 A/dm². The process takes 1.5 h. The yield of plutonium and americium was 70-90%, while for uranium it amounted 60-80%. The target was washed with ethanol and calcinated at a burner. The energy resolution of an alpha-spectrum obtained by measuring the target was not more than 40 keV.

5. To reduce the volume of the initial extracting organic phase extraction chromatography on solid-phase extractants impregnated with an organic solution containing C₄mimTf₂N and Ph₂Bu₂ in DCE can be used. In this case, stripping is not required as organic solution from solid extractant pores can be reconstituted by ethanol either by washing the column (at the rate of 0.3 ml/min) or at batch conditions (in a beaker) for 30 min.

Advantages of the method:

As an electrolyte the solution of ionic liquid in the diluent (1-10 wt%) is used instead of individual 100% IL

No gas formation;

At hydrometallurgical processing of spent nuclear fuel by applying the principles of extractive TRUEX process, there is the possibility to avoid the stripping from the organic phase and to isolate actinides directly on the target for the following alpha-spectrometric determination of their content.

GRAPHENE OXIDE FOR EFFECTIVE RADIONUCLIDE REMOVAL FROM AQUEOUS SOLUTIONS

A.Yu. Romanchuk¹⁾, A. Slesarev²⁾, J. Tour²⁾, S.N. Kalmykov¹⁾

¹⁾ – *Lomonosov Moscow State University, Moscow, Russia, 119991*

²⁾ – *Rice University, Texas, USA*

romanchuk.anna@gmail.com

Treatment of aqueous waste effluents and contaminated groundwater containing man-made radionuclides, among which the transuranic elements are the most toxic, is an essential task in the clean-up of nuclear legacy sites. The recent accident that included radionuclide release to the environment at the Fukushima Daiichi nuclear power plant in Japan and the contamination of the water used for cooling its reactor cores, underscores the need for effective treatment methods of radionuclide-contaminated water. In USA and Russia significant quantities of soils, sediments and groundwater have been contaminated with actinides including plutonium through activities ranging from nuclear weapons testing to Pu production to nuclear accidents. Clearing technologies should be inexpensive, swift, effective and environmentally friendly.

During last decades the interest towards the use of new carbon nanomaterials increased significantly. Among major advantages of carbon nanomaterials are their shape, size and free surface area. Among all carbon nanomaterials, graphene oxide (GO) is well studied so far and it is proven to be non-toxic and biodegradable, and can be easily produced in vast amounts which makes it perfect for environmental applications.

In this work we studied GO for rapid removal of some of the most toxic and long-lived man-made radionuclides from contaminated water. The interaction of GO with actinides including Am(III), Th(IV), Pu(IV), Np(V), U(VI) and typical fission products Cs(I), Sr(II), Eu(III) and Tc(VII) as well TENORMs like Ra(II) were studied in a broad pH range, along with their sorption kinetics. It was observed that sorption capacity of GO is close to 1 mmol/g. GO is far more effective in removal of transuranium elements from simulated nuclear waste solutions than other routinely used sorbents such as bentonite clays and activated carbon.

Cation/GO coagulation occurs with the formation of aggregates of GO sheets, facilitating their removal.

To determine mechanism of cation-GO interaction different techniques were used including HRTEM, IR spectroscopy, NMR and XPS.

These results point toward a simple methodology to mollify the severity of nuclear waste contamination that has been spawned by humankind, thereby leading to effective measures for environmental remediation.

**ELECTROCHEMICAL DISSOLUTION OF Tc – Ru ALLOYS
IN HNO₃ SOLUTION**

K.V. Rotmanov¹⁾, A.G. Maslennikov²⁾

¹⁾ - Joint Stock Company “State Scientific Center – Research Institute of Atomic Reactors”, Dimitrovgrad, orip@niiar.ru

²⁾ - Federal state budget institution of science A.N.Frumkin Institute of Physical Chemistry and Electrochemistry of Russian Academy of sciences, Moscow

The electrochemical dissolution in nitric acid-based electrolytes is a convenient way to dissolve Tc – Ru alloys generated as a result of ⁹⁹Tc transmutation. The goal of this paper is to estimate the rate of anodic dissolution of Tc – Ru alloys in 1.0 – 6.0 mol/l of HNO₃.

Electrochemical dissolution of Tc – 19wt. % Ru, Tc – 45wt. % Ru, Tc – 70wt. % Ru in nitric acid was performed under the galvanostatic mode. The anode current density (86 - 255 mA·cm⁻²) was selected for the main electrode potential to exceed the potential of Tc – Ru alloy transpassivation in the HNO₃ solution of the corresponding concentration.

The anodic dissolution of Tc – Ru alloys in 1.0 – 6.0 mol/l of HNO₃ resulted in Ru oxidation and generation of Ru(IV) as well as Tc oxidation and generation of Tc (VII). The study of kinetics of the Tc – 70wt. % Ru alloy electrochemical dissolution in the above HNO₃ concentrations showed a congruous nature of the alloy dissolution and a linear dependence of Tc(VII) and Ru(IV) accumulation versus time. The Tc dissolution rate in 6.0 mol/l of HNO₃ made up 7.03mg cm⁻² h⁻¹, while that of Ru was 12.92mg cm⁻² h⁻¹. The anodic dissolution of Tc-Ru alloys with lower Ru content was also characterized by a linear growth of Ru(IV) and Tc(VII) in the solution versus time. While soluble forms of Ru(IV) accumulated in the solution, the generation of low-soluble hydrated oxide Ru(IV) was observed. The solubility of the latter compound in HNO₃ increased as its concentration in the electrolyte became higher. It was stated that the rate of electrochemical dissolution of Tc – 70wt.% Ru alloy increased linearly as the HNO₃ concentration became higher. The Tc electrochemical dissolution rate defined for alloys with lower Ru content did not depend on the HNO₃ concentration in the electrolyte. Simultaneously with the anodic dissolution of Tc and Ru, water oxidation was observed accompanied with oxygen generation. The rate of this process increased as the Ru content in the alloy and amount of HNO₃ in the electrolyte became higher. This process decreased the current yield values for Tc and Ru dissolution. When dissolving alloy Tc – 19wt. % Ru in 6.0 mol/l of HNO₃, the current yield values made up 6.9 F/mol Tc and 7.5 F/mol Ru; when dissolving alloy Tc – 70wt. % Ru, the current yield values made up 13.3 F/mol Tc and 17.1 F/mol Ru .

Study of the nature of main electrode corrosion damage by SEM revealed uniform corrosion occurring during electrochemical dissolution of alloys Tc-Ru.

NEUTRINO EMISSION AND THE SAFETY OF NUCLEAR OBJECTS

G.B. Ryazantsev¹⁾, I.N. Beckman¹⁾, D.A. Minyaeva²⁾

¹⁾ – *Lomonosov Moscow State University, Leninskie Gory, 1 bld.10, Moscow 119991, Russia, anis-mgu@mail.ru*

²⁾ - *Mendeleyev University of Chemical Technology of Russia*

In 1979, there was a serious accident in the U.S. at the Three Mile Island nuclear power plant which involved two power-generating units. In 1986, the world witnessed a large-scale disaster in the USSR at the Chernobyl nuclear power plant that operated four power reactors. The last major accident occurred in March of 2011 in Japan. That accident involved six reactors. It is known that during the nuclear reactions in the reactors the torrents of anti-neutrino are released. At first, the neutrino emission was postulated as extremely high-penetrating, practically non-reactive to the matter. However, the capture cross sections of neutrinos, although really having very low values, are being measured at the extremely rough criteria. The situation here is somewhat similar to what happened to the neutron. Neutron, too, has high penetrating capacity, and often low capture cross sections, but, nevertheless, its cases of resonant interaction processes, that have sections many orders larger than normal, are well studied. From the very beginning of the discoveries of the neutrino, the "pervasive bias" has been adopted in the description of its properties, and little is known about its possible resonant interactions with matter and the research on these interactions. Resonant interactions are widespread in the microcosm and the physics of elementary particles, and it is not prudent to deny their presence for neutrinos, even with a very small probability. It must be said that for the relic neutrinos, the high level of interaction with matter is already widely discussed, but with the caveat that it is not typical for nuclear neutrinos. It is obvious for the greater part of the neutrino energy spectrum, but not for resonance. This is the first point. But there is another point: the interaction of neutrinos with matter is among the weak interactions, but, as pointed out by Academician B.M.Pontecorvo in 1970 [1,2], and discussed even earlier – in 1964 – in the works of E.Bialynicka – Birula [3], the interaction between the particles themselves can proceed according to the mechanism of the strong interaction. This radically changes the situation; the presence of two or more neutrino fields close to each other can lead to a strong interaction between them, precisely: 1) to a sharp acceleration of the inverse beta process, which will lead to a large release of additional energy, and 2) to an increase in the fraction of excited nuclei in fissile material, which will lead to a decrease in its critical mass, and to an uncontrolled change of regime in the reactor to a supercritical state. Therefore, the work of two or more reactors located near each other is extremely worrying. The tendency to a greater increase in the number of cooperating power units (up to 7-8) is clearly showing. The conception of independence of the adjacent units, which is the prevailing conception at present, may appear misleading. At present, the most dangerous situations exist in Japan, Canada and India (NPPs with 7-8 power units); Ukraine has a nuclear power plant with 6 units (Zaporozhye); in Russia there are stations with 4-5 units. In addition to the mutual influence of nuclear power units, the question of the effect of natural neutrino torrents on their work also requires a systematic study. The methods of detecting the interactions of nuclear power units according to the neutrino mechanism are being discussed.

[1] B.M. Pontecorvo, *Uspekhi phisicheskikh nauk*, 104, №1, 10 (1971) (in Russian);

[2] D. Bardin, S. Bilenky, B. Pontecorvo, *Phys. Lett.* 32B, 121 (1970);

[3] Z.Bialynicka - Birula, *NuovoCim.* 33, 1484 (1964)

BIODESTRUCTION OF OIL-CONTAINING RW

A.V. Safonov, V.E. Tregubova

*Frumkin Institute of Physical chemistry and Electrochemistry
Russian academy of sciences, 31, Leninsky prospect, Moscow, Russia
alexeysafonof@gmail.com*

Treatment of oil-containing RW is difficult because of low inclusion of organic phase into cement matrix, exfoliated two-phase system presence in extraction processes and high fire risk in long-term storage. Oil-containing RW is presented with vacuum and transformer oils, diluents of TBP: sintin, kerosene, dodecane. In this work the possibility of biological destruction of such wastes by microorganisms obtained from oil reservoir of the Tatarstan Republic that belong to *Pseudomonas*, *Flavobacterium*, *Acinetobacter*, *Aeromonas*, *Arthrobacter*, *Rhodococcus* genera is investigated. Application of biological methods will allow to minimize significantly the volume of organic phase by relatively inexpensive processes based on enzymatic oxidation of organic molecules, and also to carry out particular sorption purification of wastes from transuranium radionuclides and cesium, as well as to fulfill emulsification of organic phase using exogenic biosurfactants - surface-active substances of glycolipid nature.

Main physiological features of the microorganisms were estimated, oil-destruction process kinetics and biosurfactant-generating ability was analysed. After 7 days of biodegradation decrease 2-10-fold in volume of oil-containing LRW to be solidified because of biodestruction of organic phase to nonradioactive gases (H_2O , CO_2 and N_2) which are removed from LRW volume is determined. On the basis of obtained data, hardware process scheme is developed and optimal conditions for its efficient behavior are selected. Oil-containing liquid radioactive wastes are subjected to biodestruction for 7-10 days at temperature of +30...35 °C in a vessel with forced mixing, at the same time microorganisms sorb radionuclides and release biogenic surfactants- emulsifier. After that obtained biomass slag is solidified with inorganic or polymeric matrix material.

Work is supported by Presidents grant MK-2330.2012.3, RFBR project № 12-08-3127412, and federal programe «Kadry» № 2012-1.2.2-12.000-2007.

NPP LIQUID RADIOACTIVE WASTE TREATMENT WITH SELECTIVE EXTRACTION OF RADIONUCLIDES

A. Savkin

FSUE "Radon", Russia, e-mail: savkin_ae@mail.ru

The major types of LRW formed during NPP maintenance are the following:

- Evaporator concentrate;
- Filter pulps, mainly of ion-exchange resins;
- Salt residue.

The salt residue is a product, resulting from drying of evaporator concentrates, but it is not a conditioned product, therefore it was intentionally classified as LRW.

FSUE "Radon" jointly with some other companies developed ion-selective treatment technology for purification of evaporator concentrate from all the radionuclides (Cs, Co, Mn etc.). The matter of the method consists in the following. Evaporator concentrate is subjected to pretreatment before selective sorption. Pretreatment includes two stages: ozonization and separation of sediment obtained. Pretreatment is aimed at:

- destruction of organic complexes connecting radionuclides of Co, Mn etc.;
- destruction of organic substances contaminating selective sorbents;
- separation of sediment, where the main quantity (> 99%) of Co, Mn radionuclides is concentrated.

After pretreatment the solution is sent to selective purification from Cs radionuclides on inorganic sorbents in filter-containers. After solidification obtained filtrate is stored as non-radioactive waste. The scheme has been tested in the laboratories of different NPPs: Kalinin, BN-350, Novovoronezh, Leningrad, Kola and Kursk. Later on this technology was tested at bench plants at Kola NPP and BN-350, as well as at the pilot plant in the Institute of Physics and Power in Obninsk.

All the engineering and technological solutions have been realized at the industrial-scale plant for evaporator concentrate treatment at Kola NPP. By now, ~ 1000 tons of non-radioactive salts have been obtained. RW reduction factor is ~ 80.

Salt residue, formed in the result of deep evaporation of NPP evaporator concentrate, is non-conditioned product. Its storage at NPP sites poses a serious threat for environment. In laboratories there were held experiments on treatment of salt residue from Novovoronezh NPP. Thereby 3 ways of processing were offered and tested.

1-st way consists in salt residue dissolution and then its processing, including oxidation, separation of the sediment obtained and selective treatment on ferrocyanide sorbents.

2-nd way consists of fusion of the salt residue, addition of glassforming additives and melting of borosilicate glass in a melter such as a "cold crucible"..

3-rd way consists of dissolving the salt residue, oxidation of the solution obtained, removal of radionuclides by collectors and the separate handling of formed deposit and the solution. The deposits containing more than 99 % of the activity are directed to vitrification, and the solution is directed either to a concentrates dryer or to cementation.

All the options have been fulfilled. The largest RW reduction factors are achieved in 1 and 3 variants.

For treatment of spent ion-exchange resins there was offered and tested the following method – dissolution of ion-exchange resins in hydrogen peroxide at high temperature with ozone afteroxidation of solution obtained. Later on this solution is handled like NPP evaporator concentrate. It has been shown in the course of trials that using indicated methods while processing of ion-exchange resins together with evaporator concentrate makes it possible to reduce radwaste volume more than 50 times. Solution obtained thereafter is non-radioactive.

Different scale researches made it possible to suggest the scheme for treatment of LRW accumulated at NPPs (for WWER reactor). According to the scheme it's possible to process evaporator concentrates, ion-exchange resin pulps and radioactive salt residue at one unit.

EXTRACTION OF YTTRIUM BY NEW ORGANOPHOSPHORUS LIGAND

N.N. Senik, B.V. Egorova, S.N. Kalmykov, I.E. Nifant'ev

*Lomonosov Moscow state university, Moscow, Russia
nadezdasenik@mail.ru*

Rare earth elements (REE) are widely used in various advanced functional materials due to their unique fluorescent, magnetic, optical, and catalytic properties. Thus, the recovery of RE metals from minerals is of significant practical interest. Moreover effective REE extraction could be useful in spent nuclear fuel reprocessing since trivalent actinides and lanthanides have chemically similar behavior. At the present time bis(2-ethylhexyl)hydrogen phosphate (D2EHPA) is widely used for this purpose. However, separation of adjacent REE metals due to the similarity in their chemical properties is still an important problem. Consequently the search for new ligands should be carried out among D2EHPA analogs. This work presents the first experimental data on extraction behavior of Y^{3+} by new aryl-containing phosphorus ligand **HL**.

Stock solutions of $Y(NO_3)_3$ $c=1.0 \cdot 10^{-5}M$ with Y-90 as a tracer and ionic strength 0,1M $NaNO_3$ were prepared with different pHs between 1-5. Aqueous to organic ratio was kept at 1:1 in all experiments. Cation distribution between organic and aqueous phase was controlled using liquid scintillation counting (LSC). It was shown that under extraction 3 protons per 1 cation are released (fig.1). The following extraction reaction is proposed:

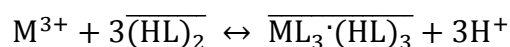

The calculated extraction constant $\lg K_{ex} = -2.37(5)$.

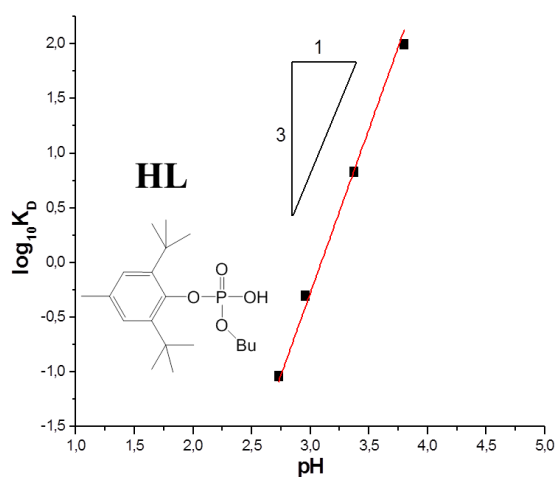

Fig. 1. pH dependence of Y^{3+} distribution ratio.

RADIOCHEMICAL ISSUES OF CLOSED NUCLEAR FUEL CYCLE

A. Shadrin, K. Dvoyeglazov, V. Ivanov, V. Volk

***Bochvar All-Russian Scientific Research Institute for Inorganic Materials
(VNIINM), Rogova St 5a, Moscow, Russian Federation, 123098***

Further development of nuclear energy is impossible without solving the number of problems concerning safety, environmental acceptability and economic efficiency. Some of these problems are connected with spent nuclear fuel (SNF) management, since SNF accumulation has become a real barrier for nuclear energy development. In the long term SNF management problems should be solved through nuclear fuel cycle (NFC) closing with utilization or recycled plutonium and neptunium and burning of minor actinides.

It can be seen easily that closed nuclear fuel cycle (CNFC) of the future is energetic system based on combination of fast and thermal neutron reactors. Although multiple ways of transition to CNFC are possible some key radiochemical technologies must be appointed. If these technologies are not improved from the point of safety, ecological and economic requirements the CNFC realization will be impossible. Development of these technologies requires research data including fundamental on following processes:

- synthesis of mixed U-Pu-Np-Am compounds that form initial material for fuel fabrication;
- transplutonium elements extraction and separation;
- actinides extraction and separation, preferably in non-aqueous media;
- production of stable matrixes for long-term storage (allowing further long-living nuclides transmutation) and for final disposal of nuclear waste.

The list given is not closed. There is also need in techniques for nuclides and stable elements real-time analytical control in different (mainly, non-aqueous) media and in technologies for production of new radiation-resistant non-activating under radiation exposure construction materials stable in aggressive media.

SUPPRESSION OF RADIOACTIVE SUBSTANCES IN AIR FILTERS

S.M. Shevchenko

*FSUE "RADON", Moscow
post-sergey@mail.ru*

Work was undertaken in 2011 and 2012 to develop a technology for suppression of radioactive substances in air filters. The purpose of the work was to develop, for avoiding the ingress of radioactive substances in the form of dust into workrooms during fragmentation of filters and grading of fragments, a technique (technology) for the suppression of radioactive substances in air filters with packages to be further prepared for processing by compaction and combustion methods.

The technology for radioactive substances suppression in air filters consists in that aqueous reagent solutions comprising binding and superficially active substances (SAS) are injected into the filtering material which contains coarse and fine dust particles. This immobilizes and suppresses coarse and fine dust particles, including radioactive dust particles, which have been retained by the filters and are present on the filter bodies. The technique is based on the movement of the aqueous reagent solutions through the immovable layers of fine and/or coarse particles which form deposits on the filtering materials, as well as of the particles which have penetrated into the filtering materials. The deposition layers may be monodispersed or polydispersed depending on the size of the particles in one and the same layer. When the aqueous solutions move through the deposition layers, while filling in the free space between the layer particles, the aqueous solution simultaneously flows over separate layer particles and moves inside irregularly shaped channels formed by gaps between particles and pores. Thanks to this movement of the solution, particles are wetted and the transport of the substances contained in the solution to the deposit particles is improved. For better wetting of particles, superficially active substances (SAS) are added to the solution, the molecules of which reduce the superficial tension of the aqueous solutions and improve their wetting capability thanks to the SAS molecule absorption on the surface of the deposition layer particles. The binding substances bind fine and coarse particles.

The work also involved determination of the optimal rate of the reagent feed into the filtering material to enable reliable immobilization and prevent the removal of radioactive substances.

A fundamental difference of this technology from other methods and techniques to handle radioactively contaminated filters is that it ensures radiation-safe grading and fragmentation of filters during separation of the filter components depending on the processing method (compaction or combustion).

This technology, as combined with the compaction and combustion technologies, makes it possible to process radioactive waste with much smaller radioactive waste amounts generated and the resultant radioactive waste forms which are fit for safe storage and/or disposal.

COMPARISON OF RADIONUCLIDE DIFFUSION COEFFICIENTS IN GLASSES, GLASS-CERAMICS, AND CERAMICS

S.V. Stefanovsky^{1,2)}, I.A. Ivanov³⁾

- ¹⁾ - FSUE "Radon", 7th Rostovskii lane 2/14, Moscow 119121 Russia
²⁾ - Frumkin Institute of Physical Chemistry and Electrochemistry RAS, Leninskii av. 31, Moscow 119071 Russia, profstef@mtu-net.ru
³⁾ - St-Petersburg State Institute of Technology, Moscovskii av. 26, St-Petersburg 198013 Russia

Radioactive wastes contain fission (Cs, Sr, Tc, Ru, I, Ln = La...Gd, etc.), corrosion products (Cr, Mn, Fe, Co, Ni, Cu, Zr, etc), and actinides (An = U, Np, Pu, Am, Cm). Diffusion of radionuclides is a determining factor for their leaching behavior. Among various waste forms which are under consideration now the high-temperature forms – glasses, glass-ceramics, and ceramics seem to be the most promising forms. The goal of our work was to measure and compare diffusion coefficients (D_c) in some of these materials. The D_c values in baseline and high level waste (HLW) surrogate bearing borosilicate (BS) and aluminophosphate (AP) glasses, Cr-containing sphene-based glass ceramics (GC), and three Synroc-C ceramic samples: one – produced by hot-pressing at ANSTO, Australia (HP), and two – produced by melting in a resistive furnace (RF) and in a cold crucible (CC) at FSUE "Radon", were measured by an integrated residual activity procedure (Table).

Table. Radionuclides diffusion coefficients in various waste forms.

Material	T (°C)	Diffusion coefficient (m ² ·s)					
		²² Na	⁹⁰ Sr	¹³⁷ Cs	²³⁷ Np	²³⁹ Pu	²⁴¹ Am
Baseline BS glass	500	2.8·10 ⁻¹⁴	5·10 ⁻¹⁸	6·10 ⁻¹⁸	~10 ⁻¹⁹	~10 ⁻¹⁹	~10 ⁻¹⁹
HLW surrogate bearing BS glass	500	2.7·10 ⁻¹³	3·10 ⁻¹⁸	3·10 ⁻¹⁸	~10 ⁻¹⁹	~10 ⁻¹⁹	~10 ⁻¹⁹
Baseline AP glass	400	1.1·10 ⁻¹²	7.2·10 ⁻¹⁷	2.2·10 ⁻¹⁶	2·10 ⁻¹⁸	2·10 ⁻¹⁸	1·10 ⁻¹⁸
HLW surrogate bearing AP glass	400	5.6·10 ⁻¹³	5.0·10 ⁻¹⁷	2.0·10 ⁻¹⁷	2·10 ⁻¹⁸	2·10 ⁻¹⁸	1·10 ⁻¹⁸
REE-bearing AP glass	400	-	-	-	-	~10 ⁻¹⁸	~10 ⁻¹⁸
Sphene-based GC	400	-	2·10 ⁻¹⁷	4.4·10 ⁻¹⁵	-	-	9·10 ⁻¹⁶
Synroc-C, HP	400	-	8·10 ⁻¹⁸	2·10 ⁻¹⁶	-	-	9·10 ⁻¹⁶
Synroc-C, RF	400	-	4.1·10 ⁻¹⁶	4.0·10 ⁻¹³	-	-	2.0·10 ⁻¹⁵
Synroc-C, CC, annealed	400	-	9·10 ⁻¹⁷	7.1·10 ⁻¹⁴	-	-	3.0·10 ⁻¹⁶
Synroc-C, CC, quenched	400	-	5·10 ⁻¹⁷	1.6·10 ⁻¹⁵	-	-	3.0·10 ⁻¹⁶

The D_c values in glasses decrease in the row: ²²Na ≥ ⁹⁰Sr, ¹³⁷Cs > actinides. In glass-ceramics and ceramics Cs⁺ is the most mobile cation and the D_c values for An may exceed those for Sr²⁺ by 1-2 orders of magnitude due to features of elemental partitioning between the co-existing phases. While glasses are homogeneous, glass-ceramics and Synrocs are heterogeneous and ionic diffusion may proceed by phase (grain) boundaries, in residual vitreous phase, and due to migration along microcracks and pores. Therefore the D_c values measured are averaged values over all the migration paths; in particular, they are dependent on method of sample preparation.

EXTRACTION OF ACTINIDES BY DIAMIDES OF 2,2'-DIPYRIDYL-6,6'-DICARBOXYLIC ACID

L.I. Tkachenko¹⁾, M.Yu. Alyapyshev¹⁾, V.A. Babain¹⁾, N.E. Borisova²⁾

¹⁾ – *V. G. Khlopin Radium Institute, 2nd Murinskiy Ave 28, St. Petersburg, Russia, 194021, ltkachenko@khlopin.ru*

²⁾ – *Lomonosov Moscow State University, GSP-1, Leninskie Gory, Moscow, Russia, 119991*

The removal of minor actinides (MA), especially americium, from high level waste, allows the recycling it as a nuclear fuel. The most difficult problem for minor actinides removal is separation them from fission lanthanides, owing to similar chemical behavior of these metals. Solvent extraction is one of well-known and effective methods for metal ions separation.

New solvents and extraction processes for the minor actinides separation from high level waste are under development worldwide. Diamides of dicarboxylic acids have been studied as promising extractants for the last decades. Diamides of 2,2'-dipyridyl-6,6'-dicarboxylic acid (Dyp) are rather new class of diamides extractants. In our previous work the selective extraction of actinides (III) over lanthanides (III) by Dyp-ligands was shown. Separation factor 10 or more for extraction of Am and Eu from high acidity media was found.

In the present work the extraction of actinides from nitric acid with solvents on the base of Dyp-ligands in polar fluorinated diluents - meta-nitrobenzotrifluoride was studied. It was demonstrated that Dyp-ligands selectively extract actinides (uranium (VI), neptunium (V), plutonium (IV), americium (III), curium (III)) from 3 M nitric acid. It was shown that the separation of actinides (III) from other actinides can be achieved by varying of nitric acid concentration.

The flowsheet for separation of actinides (particularly americium (III)) from fission lanthanides was developed. The batch tests using simulated solution were carried out. In the framework of proposed flowsheet less than 1 % of lanthanides have been observed in americium strip product.

Advantages and drawbacks of new extraction system on the base of Dyp-ligands were discussed to compare of classical flowsheets for separation of actinides (III) and lanthanides (SETFICS-process) and flowsheets on the base of 2,6-bis(5,6-dialkyl-1,2,4-triazin-3-yl)pyridines (BTP).

RADIOCHEMISTRY AT THE LOVIISA NUCLEAR POWER PLANT

L. Togneri

Radiochemistry, Loviisa NPP, Finland, laura.togneri@fortum.com

Radiochemistry is part of the Operation Unit and the Operation Chemistry Group at the Loviisa Nuclear Power Plant (two pressurised water reactors, VVER-500).

The main responsibilities of Radiochemistry at Loviisa are process monitoring and monitoring of the radioactive releases. The process monitoring includes following the activity present in the primary circuit and other systems, monitoring the condition of the cladding tubes and identifying fuel leakages, and monitoring the condition of the purification systems. Evaluation of the foreign substances and the level of corrosion in the primary circuit are done in collaboration with other sections in Operation Chemistry. All release waters and the air going out of the stack are monitored for radioactivity. Radiochemistry also conducts most of the required radiochemical separation analyses from waste samples.

There are four liquid nitrogen-cooled HPGe detectors in the laboratory, two for active samples (~25 %) and two for release samples (~65 %). Most samples are measured for gamma activity before further analysis. Liquid scintillation counter is used for beta and total-alpha measurements from water samples and a proportional counter for alpha-beta measurement from aerosol filters. Loviisa NPP has purchased an alpha spectroscope and the methods are under validation.

Loviisa NPP has continuously worked toward decreasing the radiation doses obtained by workers and the levels of released activity. Radiochemistry plays a vital role in both these endeavors.

During the 80's and 90's extensive work was done to decrease the levels of Cobalt in the reactor water. The activity levels of Co-60 have decreased significantly since then. At the moment, antimony nuclides cause about 50 % of the radiation dose levels in the steam generator room. The source of antimony has been identified to be the sealing material in the main pumps. A new antimony-free sealing material has been tested and will hopefully replace the old material by 2015. An antimony selective resin (SbTreat) has been developed in collaboration with the University of Helsinki and has been tested both in the laboratory conditions and connected to the process. The experiments will continue in late 2013.

During the 90's a Cs-selective resin (CsTreat) was developed in collaboration with the University of Helsinki. The material has been used at Loviisa NPP on a campaign basis. Other materials have also been tested (SrTreat, CoTreat), but they do not work well enough with the pH levels and the chemical composition of the waste waters in Loviisa NPP. At the moment a new material is being tested to remove Nickel (NiTreat) from the waste waters.

**IMMOBILIZATION OF LONG-LIVED IODINE AFTER
INCORPORATION INTO APATITE MATRICE**

N. Torapava, C. Walther

***The Institute for Radioecology and Radiation Protection, Leibniz University of
Hanover, Herrenhäuser Str. 2, 30419 Hanover, Germany***

Iodine-129 being long-lived volatile fission product, among with cesium-135 and technitium-99, represents a challenge for the design of repository-suited matrices [1]. The present study investigates a possibility of iodine incorporation in the forms of iodide and iodate into apatite and hydrotalcite-like matrices. The matrice should meet certain requirements, i.e. being cheap, safe, easy to synthesize, stable and environmental friendly. Optimization of coprecipitation method for synthesis of iodine containing apatite has been done. Obtained matrices will be characterized by SEM and XRD. Stability in the temperature range 100 - 700°C is studied. Pellets fabrication using hot press will be done by the time of the conference. Leaching experiments in MQ water and brine will be done as well as radion damage (α -, γ -) will be studied before the conference.

[1] Watanabe et al. (2009) *Appl. Mater. Interf.* **1**, 1579 – 1584.

**ESTIMATION OF LIQUID RADIOACTIVE WASTE DEGRADATION
BEFORE SOLIDIFICATION POSSIBILITY**

V.E. Tregubova¹⁾, A.V. Safonov¹⁾, O.A. Gorbunova^{1,2)}

*¹⁾ - Frumkin Institute of Physical chemistry and Electrochemistry
Russian academy of sciences, 31, Leninsky prospect, Moscow, Russia*

*²⁾ - FSUE "RADON", 2/14, 7th Rostovsky lane, Moscow, Russia,
olg-gorbunova@yandex.ru, alexeysafonof@gmail.com*

The possibility of preliminary microbiological treatment of oil- and nitrate-containing liquid radioactive waste (LRW) before solidification in the cement matrix was investigated. Microbiological destruction is typical for oil- and nitrate-containing cement compounds of long-term storage by the reaction of biogenic organic acids with cement matrix minerals. Biodegradation of LRW components is reasonable before solidification because it reduces volume of LRW and prevents destruction of inorganic cement matrix.

Biodegradation of oil-containing LRW is possible when using radio resistant microflora for oxidation of oil organic components to carbon dioxide and water, with parallel biosorption of radionuclides by bacteria, followed by oil emulsification in cement solution by biosurfactants formed by biodegradation (surface-active substances of glycolipid nature). After 7 days of biodegradation decrease in the volume of oil-containing LRW to be solidified is found to be reduced 2-10-fold because of biodestruction of organic phase to nonradioactive gases (H₂O, CO₂ and N₂) which are removed from LRW volume.

Biodegradation of nitrate-containing LRW is possible when using radio resistant microflora for denitrification of nitrate-ions which are the main component of LRW. The process is realized by enzymes catalyzing cellular respiration with consecutive reduction of nitrate-ions to molecular nitrogen through stages of nitrite, nitrous and nitric oxide forms. After 3 days of biodegradation, the concentration of nitrate is found to be reduced from 4 g/dm³ to 10-15 mg/dm³. At the same time by sorption processes at cellular structures microorganisms are able to remove 80-90% of α -radionuclides, up to 50% ⁹⁰Sr and 20% ¹³⁷Cs from LRW. Radionuclide containing biomass has to be dried up and solidified into cement matrix.

The work is supported by Presidents grant MK-2330.2012.3, RFBR project № 12-08-3127412, and federal programme «Kadry» № 2012-1.2.2-12.000-2007.

**TECHNETIUM AS A PERSPECTIVE FORM FOR IMMOBILIZATION
INTO ENVIROMENT AND IN RADIOMEDICINE**

V. Tregubova¹⁾, A. Safonov¹⁾, K. German¹⁾, V. Peretrukhin¹⁾, F. Poineau²⁾

¹⁾ - Frumkin Institute of Physical chemistry and Electrochemistry

Russian academy of sciences, 31, Leninsky prospect, Moscow, Russia

*²⁾ - University of Nevada Las Vegas 4505 S Maryland Pkwy Las Vegas, NV
89119, USA alexeysafonof@gmail.com*

Feature physico-chemical properties of technetium and heterovalent compounds, namely their high volatility and solubility in aqueous and organic mediums, leads to technetium gets into all types of radioactive waste during the reprocessing of irradiated fuel. Thus, only in the very recent it was begun to understand the chemical form of technetium sulfide, however, to date, neither the kinetics of its formation or performance of the colloidal particles, nor the value of the thermodynamic solubility of the compound has not been described in the literature. Given the importance of these characteristics to analyze the possible formation of technetium sulfide in natural waters, which are in contact with the H₂S-producing sediments, we present a spectrophotometric study of the kinetics of its formation and ultrafiltration analysis of the effect of concentration of sulfide ion on the size and stability of colloidal particles of sulphide technetium in this paper.

The kinetics of Tc reaction with sulfide ions was investigated, and the reaction is shown to be preceded by an induction period, increasing from 10 minutes to 9 hours while the pH changed from 11 to 8.2, the reaction rate increases linearly with increasing concentration of technetium. Correctly describe change in solubility of technetium sulfide depending of sulphide ions content in the solution and calculate the true value of its solubility can only using ultrafiltration. When the concentration of sulfide ions from 0.02 M to 0.05 M technetium sulphide formed is unstable.

The likely mechanism of uptake of technetium (VII) by the sludges is its reduction to Tc (IV), accompanied by either complexation with components of microbial cells or the deposition of hydrated Tc dioxide on intracellular structures.

THE STUDY OF CO-CRYSTALLIZATION OF URANIUM AND PLUTONIUM NITRATE HEXAHYDRATE IN THE PROCESS OF MIXTURE UNDIVIDED REFINING CRYSTALLIZATION

V.I. Volk, L.V. Arsenkov, S.A. Nikonov, S.N. Veselov

JSC "VNIINM", Russia, Moscow, st. Rogova, 5a, s.nikonov88@mail.ru

Production of mixed uranium-plutonium fuel includes steps of obtaining a master mix (U, Pu)O₂ with a ratio of Pu/U $\geq 0,25$ and subsequent "dry" adjustments of this ratio by adding the required amount of UO₂.

The important circumstance in manufacture master mixture is achievement of limiting, at a level of a solid solution, homogenization UO₂ and PuO₂. Use of the necessary compounds-precursors is a prerequisite for such homogenization. Uranium and plutonium nitrates are such compounds. Co-crystallization of hexahydrates UO₂(NO₃)₂ • 6H₂O and PuO₂(NO₃)₂ • 6H₂O is both refining operations [1,2] for undivided mixture of uranium and plutonium and the operation to achieve desired chemical form for subsequent conversion into (U, Pu)O₂.

The report presents the results of research on such co-crystallization.

The process includes the following steps:

1. Preparation of the solution with the desired ratio of Pu/U
2. Evaporation of the solution to high concentrations of metals (to melt)
3. Valence pairs U (VI)-Pu (VI) stabilization.
4. Updating of a solution with an output to optimum contents for carrying out of crystallization of the basic component UO₂(NO₃)₂ • 6H₂O on the set working line.
5. Co-crystallization UO₂(NO₃)₂ • 6H₂O and PuO₂(NO₃)₂ • 6H₂O. Determination of the composition of the mother liquor and the operational salts output to the crystalline phase.
6. Definition of co-crystallization factors in the direct (crystallization) and reverse (crystals washing) process.

Main results:

1. The ratio of Pu/U is regulated by extraction of uranium from reduced plutonium reextract (the U (VI)-Pu (III) pair)
2. Evaporation is performed in two stages with control of condensate volume for necessary removal of nitric acid.
3. Stabilization of U (VI)-Pu (VI) pair occurs in the steps of evaporation and bottoms solution staying.
4. The optimum composition of melt for crystallization corresponds to the equation of the working line $[MN] = 78,49 - k[HNO_3]$, where [MN] and [HNO₃] - concentration, (wt.%), of uranium and plutonium nitrates and nitric acid, the value of [MN] is not less, than 60% and the coefficient k is limited by interval $2,25 \geq k \geq 1,5$.
5. Amount of uranium and plutonium yield to the crystalline phase is determined by crystallization temperature and with sufficient accuracy corresponds to a yield of uranium in the ternary system of UO₂(NO₃)₂-HNO₃-H₂O.
6. The plutonium cocrystallization factor for in forward and reverse process is in the range of (0,65-0,90) and increases (in the investigated range of Pu/U) with increasing fraction of uranyl nitrate in the system.

**STUDY ON SEPARATION OF AMERICIUM AND EUROPIUM BY
INORGANIC EXCHANGER ZIRCONIUM PHOSPHATE**

E.W. Wiikinkoski, R. Harjula

*Laboratory of Radiochemistry, Department of Chemistry, University of
Helsinki, A.I. Virtasen aukio 1, PO.Box 55, 00014 University of Helsinki,
Finland*

e-mail: elmo.wiikinkoski@helsinki.fi

Worldwide on-going research on partitioning and transmutation (P&T) is an attempt to advance nuclear energy industry by multiple means. The research aims to maximize fission energy gain from bulk nuclear fuel while minimizing long term radiotoxicity of nuclear fuel waste. New partitioning methods are also essential in the development of closed fuel cycles. By the means of P&T, it is possible to recycle a fraction of used fuel, to shorten the time for fuel to cool down in temporary waste storages by addressing nuclides generating large amounts of heat and to lessen the radioactivity in nuclear waste final repositories.

This study aims to develop hydrochemical separation methods based on inorganic ion exchangers. Inorganic materials offer a superior radiation resistance over organic counterparts. Ideally inorganic resin could offer a separation of either specific nuclides or groups of nuclides straight from spent nuclear fuel dissolved in nitric acid resulting in a more straightforward method free of organic solvents. Alternate use would be the treatment of secondary waste streams formed in current hydrochemical partitioning methods. The aims are to develop exchangers capable of separating actinides from lanthanides, modeled by close counterparts americium and europium. Main advances that will be presented include revised synthesis of the ion exchanger of interest - α -zirconium phosphate, further structural investigation and column separation experiments in nitric acid. Fig 1 shows experimental distribution coefficients in nitric acid for three α -zirconium phosphates.

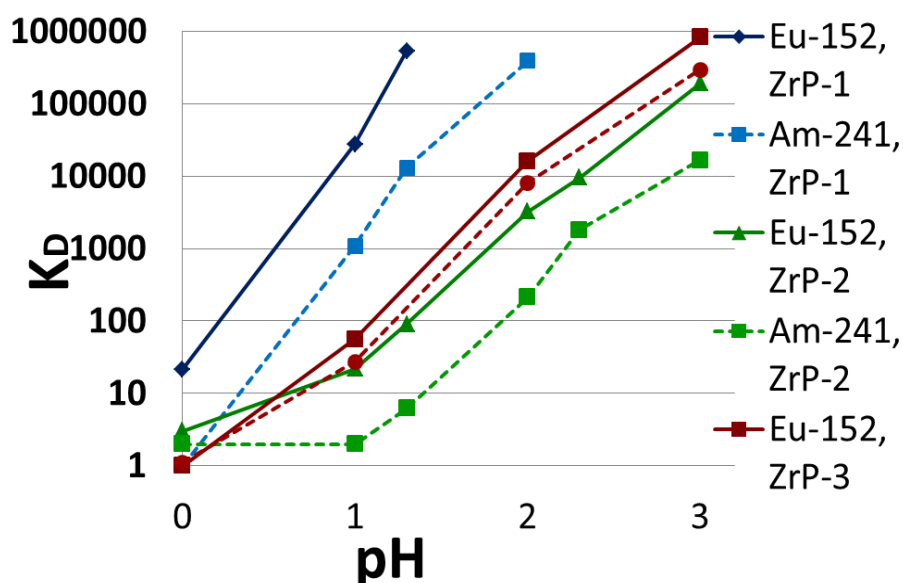

Fig. 1. Experimental distribution coefficients in nitric acid.

**MANAGEMENT OF HIGH LEVEL WASTE DERIVED IN THE
CLOSED NUCLEAR FUEL CYCLE**

S.V. Yudintsev

*Institute of geology of ore deposits, petrography, mineralogy and
geochemistry, Staromonetny lane 35, 119017 Moscow, syud@igem.ru*

High level waste (HLW) are produced in closed nuclear fuel cycle (NFC) in the course of reprocessing spent nuclear fuel (SNF). The HLW should be immobilized into durable form (matrix) and disposed of in deep geological repository. Current liquid HLW of conventional PUREX technology are solidified into alkaline B-Si or Al-P glasses. The main problem of the materials is their high solubility in hot underground waters. Also the matrices are subjected to devitrification at heating during short-lived radionuclides decay influenced their isolational properties. Nevertheless due to matured and proved process of the high radioactive glass fabrication the method is the only industrial way of HLW isolation implemented in the world.

One of the approaches to improve significantly current state in the field of liquid HLW immobilization is partitioning of the waste onto groups of elements for separate management. This way suggests immobilization of long-lived actinides into durable materials composed of the synthetic minerals, while heat emitted radionuclides of Cs-Sr group can be inserted into glasses or ceramics for temporary storage in the near surface repository before their ultimate geological disposal. This approach will allow reducing a cost for management of high level radioactive waste as only long-lived nuclides will be disposed deeply in the Earth. The latest results on mineral-like matrices with pyrochlore or garnet-type structure for immobilization of the Ln-actinide fraction as well as iron-based alloys for technetium isolation are discussed.

Development of advanced NFC based on the fast neutron reactors requires new “dry” technologies for the SNF reprocessing. This technology produces specific kinds of high level waste, for example spent electrolyte containing isotopes of Cs and Sr and lanthanides as well. To isolate these wastes special matrices are developed for example glasses, glass ceramics and crystalline materials. Properties of the promising forms for radioactive salts are discussed. Most common algorithm for selection optimal ways for HLW immobilization is suggested. This approach considers the main factors influenced SNF and HLW compositions: initial fuel, its burn up, neutron spectrum, SNF cooling time and technology of its reprocessing.

The study is supported by Program #4 of the Russian Academy of Sciences Presidium.

RECOVERY OF ACTINIDES AND LANTHANIDES BY NOVEL SOLID-PHASE EXTRACTANTS FROM NITRIC ACID SOLUTIONS

**E.A. Zakharchenko, N.P. Molochnikova, O.B. Mokhodoeva,
G.V. Myasoedova**

GEOKHI RAS, Moscow, Kosygin Str, 19, polyorgs@mail.ru

Solid-phase extractants (SPE) prepared by impregnation of solid supports with ligands are widely applied in radiochemistry for recovery, preconcentration and separation of radionuclides. This is due to their high efficiency, selectivity of sorption recovery and simplicity of preparation. Sorption ability of the SPE depends on properties of impregnated ligands and solid supports as well as extraction conditions (HNO_3 concentration, the presence of macrocomponents, etc.). For the SPE preparation it is very promising to apply the new types of solid supports: carbon nanomaterials, high-porous and fine-dispersive polymers, which ensure strong retention of impregnated ligands and good kinetic properties.

This presentation is focused on the sorption ability of the novel SPE prepared on the base of carbon nanotubes (Taunit, Russia) and high crosslinked (Isolute 101, Sweden) or hyper crosslinked (Macronet, the GB) polystyrene for extraction of actinides and lanthanides in nitric acid solutions. We used ligands which possess the high efficiency in nitric acid solution such as $\text{Ph}_2\text{Bu}_2\text{CMPO}$, TODGA, TOPO, as well as phosphonium ionic liquid Cyphos IL101 which could be kept on the solid phase and extract some radionuclides. Impregnation of solid supports was carried out directly in nitric acid using the specially developed technique. The ligand content in the SPE phase was 0.5-0.9 mmol/g.

The SPE and conditions of actinide and lanthanide extraction from nitric acid solutions are given in the Table.

SPE	HNO_3 concentration	Extractable elements
Taunit- $\text{Ph}_2\text{Bu}_2\text{CMPO}$, Macronet- $\text{Ph}_2\text{Bu}_2\text{CMPO}$, Isolute- $\text{Ph}_2\text{Bu}_2\text{CMPO}$	3-6 M	U(VI), Pu(IV), Th(IV), Am(III), Eu(III), La(III), Ce(III)
Taunit-TODGA, Isolute-TODGA	1-6 M	
Taunit-TOPO, Macronet-TOPO, Isolute-TOPO	0.1-6 M	U(VI), Pu(IV), Th(IV)
Taunit-Cyphos IL101, Macronet- Cyphos IL101, Isolute-Cyphos IL101	1-3 M	Pu(IV), Th(IV)

The novel SPE are intended for sorption recovery of actinides and lanthanides from nitric acid solutions in batch or dynamic (using microcolumns) mode. In this work we determined the regimes of the sorption recovery of actinides from 3 mol/L HNO_3 and their desorption using oxyethylidenediphosphonic acid as an eluent. The developed techniques can be used for analytical determination of radionuclides in solutions.

The work was supported by the Program of the Presidium of RAS No 9 and RFBR (grant No 11-03-01111).

**SORPTION OF CESIUM RADONUCLIDES BY FERROCYANIDE
SORBENTS BASED ON CARBON FIBERS**

V.V. Zheleznov, I.V. Sheveleva, V.G. Kuryavyi

*Institute of Chemistry, Far-Eastern Branch, Russian Academy of Sciences
159, Prosp. 100-letya Vladivostoka, Vladivostok 690022, Russia
zheleznov_sergey@mail.ru*

The adsorption capacity of sorbents produced by combination of the methods of thermal treatment and electrochemical and chemical precipitation of transition metal ferrocyanides on the carbon fiber matrix has been investigated. It was demonstrated that kinetic and sorption characteristics of composite materials depended on the production method affecting the sorbent morphology and structure.

Based on the presented data, one can conclude that the method of synthesis of composite ferrocyanide sorbents using the thermal destruction of transition metal salts with organic acids enables one to obtain sorbents with high content of the active ferrocyanide component on different types of carbon fiber materials.

The electrochemical deposition of siloxane-acrylate emulsion with impregnated compounds of transition metals followed by thermal and chemical treatment allows formation of composite materials with ferrocyanide microcrystal sizes of ≈ 50 nm. The most promising sorption materials, which can remove cesium radionuclides from radioactive waste with the distribution coefficient $K_d=2 \cdot 10^7$ mg/g of transition metal, were obtained at an electrodeposition potential of +0.3 V.

3. Nuclear Medicine

**RADIATION ENGINEERED POLYMER NANOCARRIERS FOR A
NEW GENERATION OF NANOPARTICLE BASED TUMOR SPECIFIC
RADIOPHARMACEUTICALS**

**C. Dispenza^{1,2)}, M.A. Sabatino¹⁾, L. Ditta¹⁾, N. Grimaldi¹⁾, M. Mangione²⁾,
G. Adamo³⁾, S. Rigogliuso³⁾, D. Bulone²⁾, G. Gherzi³⁾, M. Jonsson⁴⁾**

¹⁾ - *Dipartimento di Ingegneria Chimica, Gestionale, Informatica, Meccanica, Università degli Studi di Palermo, Viale delle Scienze, Edificio 6, 90128 Palermo, Italy*

²⁾ - *CNR - Istituto di Biofisica (IBF) UOS Palermo, Via U. La Malfa 153, 90146 Palermo, Italy*

³⁾ - *Dipartimento di Scienze e Tecnologie Biologiche, Chimiche e Farmaceutiche (STEBICEF), Università degli Studi di Palermo, Viale delle Scienze, Edificio 16, 90128 Palermo, Italy*

⁴⁾ - *School of Chemical Science and Engineering, Applied Physical Chemistry, KTH Royal Institute of Technology, SE – 100 44 Stockholm, Sweden
E- mail: clelia.dispenza@unipa.it*

Nanogels (NGs), or small particles formed by physically or chemically crosslinked polymer networks, represent a niche in the development of multifunctional nanoparticles for drug delivery and diagnostics. They offer unique advantages over other systems as nanosize delivery devices, including a large and flexible surface for multivalent bio-conjugation; an internal 3D aqueous environment for incorporation and protection of (bio)molecular drugs; the possibility to entrap molecules, metal or mineral nanoparticles for imaging or therapeutic purposes; stimuli-responsiveness to achieve temporal and/or site control of the release function and biocompatibility.

The availability of inexpensive, robust and versatile synthetic methodologies is at the basis of the development of effective nanogel-based theragnostic devices. In particular, we have established that nanogels can be produced with high yields and through-puts by pulsed e-beam irradiation of dilute aqueous solutions of water-soluble biocompatible polymers and functional monomers, e.g. poly(N-vinyl pyrrolidone) and acrylates, using industrial electron accelerators and set-ups. Nanogels are the result of chemical follow-up reactions initiated by a continuous series of electron pulse-generated hydroxyl radicals in deaerated water. A number of radical sites are generated on the polymer chains, which may have a different fate depending on the system composition and irradiation conditions. Intra-molecular and inter-molecular radical recombination as well as disproportionation, chain scission and monomer or short polymer segments grafting may occur up to different extent. As a result, crosslinked-core nanoparticles with multi-armed surfaces can be generated, with controlled size, crosslinking density, surface electric charge density, number and nature of functional groups. No recourse to organic solvents, toxic initiators or catalysts and surfactants is made, therefore expensive or time-consuming purification procedures are not required. Simultaneous sterilization can be achieved depending on the irradiation doses.

Long-term colloidal stability in the form of aqueous dispersions and redispersability from the freeze-dried form are advantageous properties especially in the view of a pharmaceutical use.

Nanogels have been decorated with fluorescent probes, peptides, antibodies, oligonucleotides, chelates for multivalent metal ions (Gd^{3+}) and/or conjugated to both molecular and macromolecular model drugs to demonstrate their amenability to be transformed into multi-functional drug nanocarriers.

The research will be now addressing the challenge of forming both in vitro and in vivo-stable complexes, through chelate interactions, with diagnostic and therapeutic cationic radioisotopes for the creation of new generation of nanoparticle-based tumor specific radiopharmaceuticals.

**YTTRIUM, LUTETIUM AND LANTHANUM BINDING BY NEW
AZACROWN LIGAND IN AQUEOUS SOLUTIONS**

B.V. Egorova¹⁾, **M.S. Oshchepkov**²⁾, **Yu.V. Fedorov**²⁾, **S.N. Kalmykov**¹⁾,
O.A. Fedorova²⁾

¹⁾ – *Lomonosov Moscow State University, Moscow, Russia*

²⁾ - *A.N. Nesmeyanov Institute of Organoelement Compounds of Russian
Academy of Sciences, Moscow, Russia*
bayirta.egorova@gmail.com

The complexation of alpha, beta and Auger emitting radionuclides is under investigation for the target delivering of them to tumor cells. One of the most common ligand used for binding of cationic species in nuclear medicine is 1,4,7,10-tetra-azacyclotetradecane-N,N',N'',N'''-tetraacetic acid (H₄DOTA). It forms thermodynamically and kinetically stable complexes with such cations as Ac³⁺, Y³⁺, Lu³⁺, Bi³⁺. However the kinetics of complexation is not always suitable in comparison with half-life periods of required nuclides. Consequently the search of new effective binding chelating molecules that would demonstrate fast kinetics of complex formation should be carried out among H₄DOTA analogs. Water soluble new DOTA-like azamacrocyclic compounds show not only thermodynamic affinity for metal cations but also demonstrate “immediate” complex formation. This work presents complexation study of Y³⁺, Lu³⁺ and La³⁺ (as Ac³⁺ analog) by new diazamacrocyclic ligand **L**.

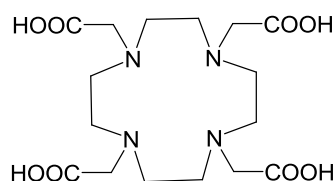

H₄DOTA

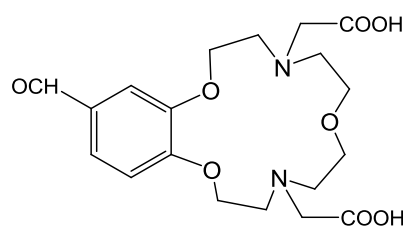

L

Stability constants of ML complexes were determined by potentiometric titration of aqueous solutions of ligand in the presence of M³⁺ cations in water-jacketed titration vessel maintained at 25.0±0.1°C. The formation of 1:1 ML complex was observed. The protonation constants of the ligand **L** and the stability constants of the complexes were calculated from the electromotive force titration data with Hyperquad software: M=Y³⁺ lgβ_{ML}=5.94±0.01; M=Lu³⁺ lgβ_{ML}=5.87±0.01; M=La³⁺ lgβ_{ML}=5.46±0.02. These values are in agreement with common tendency to stronger binding with cation hardness increasing.

The change in UV absorbance spectrum of **L** before and after M³⁺ cation addition achieves in 3-5 minutes and does not modify during days that confirms fast complex formation.

The work is supported by RFBR (project 13-03-01304).

IMPROVED SYNTHESIS OF 6-[¹⁸F]-L-THREO-DIHYDROXYPHENYLSERINE, A POTENTIAL PET RADIOTRACE FOR THE NOREPINEPHRINE SYSTEM

**O.S. Fedorova¹⁾, V.V. Orlovskaja¹⁾, D.M. Troushin¹⁾, V.I. Maleev²⁾,
T.F. Savelieva²⁾, Yu.N. Belokon²⁾, C.W. Chang³⁾, R.S. Liu³⁾, R.N.Krasikova¹⁾**

¹⁾ – *N.P.Bechtereva Institute of Human Brain, Russian Academy of Science, 9, Pavlova str., Russia*

²⁾ - *A.N.Nesmeyanov Institute of Organoelement Compounds, Moscow, Russia*

³⁾ – *National Yang-Ming University and National PET/Cyclotron Center, Veterans General Hospital, Taiwan
fedorova@ihb.spb.ru*

Very recently the 6-[¹⁸F]-L-threo-FDOPS was suggested as potential PET radiotracer that resembles L-threo-DOPS, a synthetic catecholamino acid directly metabolized into norepinephrine (NE) (Krasikova et al, *J Label Compds Radiopharm* 2011; 54, Suppl 1, S489). We assume that 6-[¹⁸F]-L-FDOPS could serve as PET diagnostic agent of neuroblastic tumours by targeting NE synthesis pathway, as well as for evaluating impairment of sympathetic system of the heart. The labeling strategy (see scheme) relies upon a multistep nucleophilic synthesis with a key asymmetric C-C bond formation step. The synthesis started with introduction of ¹⁸F into commercially available 6-nitropiperonal in which 3,4-hydroxyls were protected by methylenedioxy group. The cleavage of this protecting group required treatment with 57% HI at 180°C; however under these reaction conditions we did not observe formation of the desired product. In this work we aimed to evaluate two other benzaldehydes (BZ) with more labile methoxymethoxy (MOM) protecting groups and nitro- or fluorine-leaving groups.

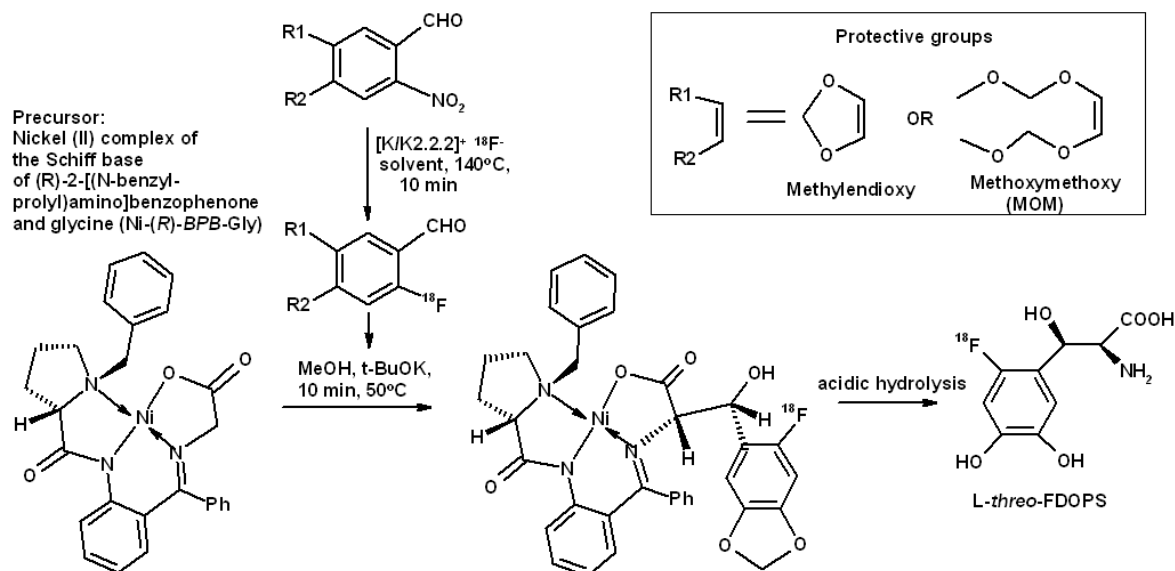

The highest ¹⁸F-fluorination yield (up to 70%) was obtained for nitro-MOM-BZ. Using this synthon the final deprotection step was completed within 5 min on heating with 3M HCL at 120 °C. 6-[¹⁸F]-L-threo-FDOPS was purified by semi-preparative HPLC. This study was supported by Russian Foundation of basic Researches, project 11-04-92010/13.

THE RADIOSYNTHESIS OF 6-^[18F]FDOPA USING ^[18F]SELECTFLUOR

S. Forsback¹⁾, A. Kirjavainen¹⁾, I. Stenhagen²⁾, V. Gouverneur²⁾, O. Solin¹⁾

¹⁾ – *Radiopharmaceutical Chemistry Laboratory, Turku PET Centre,
University of Turku, Turku, Finland*

²⁾ – *Chemistry Research Laboratory, University of Oxford, Oxford, United
Kingdom*

Here we demonstrate that ^[18F]Selectfluor *bis*(triflate) is a suitable reagent to access 6-^[18F]FDOPA from the stannyl-precursor commonly used in electrophilic radiofluorination.

Post-target produced ^[18F]F₂ was synthesized by high voltage discharge from ^[18F]CH₃F and F₂ [1]. ^[18F]F₂ was bubbled through a solution of Selectfluor *bis*(triflate) in deuterated acetone at room temperature (RT) leading to instantaneous fluorination. A known amount of ^[18F]Selectfluor crude stock solution [2] and AgOTf were added into the vial containing the protected stannyl-precursor of 6-^[18F]FDOPA, see **Fig 1**. In study 1 the reaction mixture was stirred for 20 minutes at RT and then evaporated to dryness. In study 2 the solvent was evaporated immediately after adding the crude stock solution of ^[18F]Selectfluor. After evaporation the samples from both studies were analyzed with radioHPLC.

Protected 6-^[18F]FDOPA was successfully produced using ^[18F]Selectfluor. In study 1 the radiochemical yield (RCY) was 20.3 % and in study 2 13.5 %.

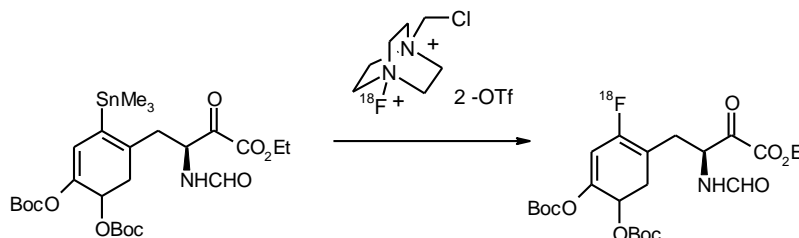

Fig 1. Synthesis of protected 6-^[18F]FDOPA using ^[18F]Selectfluor.

^[18F]Selectfluor is a selective electrophilic radiofluorination agent and it is easy to handle. It has lower reactivity as compared to the traditional agent, ^[18F]F₂, but using ^[18F]Selectfluor the introduction of “^[18F]F⁺” to a target molecule, in this case the stannylated FDOPA precursor, can be very fast.

This work was supported by the Academy of Finland (grant no. 116084 and 128591).

References

- [1] Bergman J, Solin O (1997) Nucl. Med. Biol. 24:677-683
- [2] Teare H et al. (2010) Angew. Chem. Int. Ed. Engl. 49: 6821-6824

RADIOISOTOPE GENERATORS OF SHORT-LIVED ALPHA-EMITTING RADIONUCLIDES FOR NUCLEAR MEDICINE

L.I. Guseva

*V.I. Vernadsky Institute of Geochemistry and Analytical Chemistry, RAS
Kosygin str. 19, Moscow 119991, Russia
e-mail: l.i.guseva@inbox.ru*

Physical and radiobiological properties of alpha particle radiation, such as their short path length (50 - 90 μm) in tissue and high linear energy transfer (LET $\sim 100 \text{ keV } \mu\text{m}^{-1}$), are promising in the treatment of cancer, especially when single or clusters of tumor cells are targeted. A number of pre-clinical studies have concluded that α -emitters are well suited for treatment of hematologic disease and metastasis. Alpha-particle emitters have unique properties for the local irradiation of tumors without affecting the healthy tissues, while an effective dose is 2 - 3 orders of magnitude higher than the β - emitters.

There are only a few α -radionuclides: ^{211}At , ^{225}Ac , $^{223, 224}\text{Ra}$, $^{212}\text{Pb}/^{212}\text{Bi}$, $^{211}\text{Pb}/^{211}\text{Bi}$, $^{213}\text{Bi}/^{213}\text{Po}$, ^{227}Th , ^{253}Es , ^{255}Fm which can be used for nuclear medicine. In addition to the nuclear-physical characteristics (half-life, the type of radiation, etc.) that define the scope of radionuclides (diagnostics, radiotherapy, pharmaceuticals, biomedical researches) an important role plays their accessibility, the source or method of preparation, cost, availability of appropriate laboratories and qualified personnel to work with high radioactivity.

For production of short-lived α -radionuclides in hospitals and radiochemical laboratories the most promising is a device based on their repeated isolation (milking) from long-lived parent radionuclides on the principle of radioisotope generators. The most effective and safe are ion-exchange and extraction - chromatographic generators because of the device simplicity, security, possibility of automation of the separation process highly radioactive elements and easy of transport.

The presentation is the result of our researches on the development of generators and generator systems based on ion-exchangers for production and purification of α - emitting radionuclides ^{225}Ac (10 d), ^{213}Bi (45.6 m), $^{212}\text{Pb}/^{212}\text{Bi}$ (10h/60.6m), $^{211}\text{Pb}/^{211}\text{Bi}$ (36.7m/2.1m) and ^{223}Ra (11.4 d), suitable for nuclear medicine. The static and dynamic sorption characteristics Ac, Th, Bi, Pb, Ra and other elements on ion exchangers in diluted aqueous and aqueous-organic HCl, HBr and HNO_3 solutions depending on acid concentration, composition of the solution, the nature of solvent [H_2O , CH_3OH , $\text{C}_2\text{H}_5\text{OH}$, $(\text{CH}_3)_2\text{CO}$, CH_3CN] and ion exchanger have been determined. Optimum conditions for on-line production, purification and separation of short-lived α -emitters from parent and concomitant radionuclides, as well as from inactive impurities, were found.

The ion exchange behavior of ^{223}Ra , ^{225}Ac , ^{212}Pb and $^{212,213}\text{Bi}$ in the solutions containing chelating agents (EDTA, DTPA) depending on the concentration of reagents and pH of the solutions was studied. The possibility isolation and separation Bi, Pb, Ac and Ra on the generator column using gradient elution by 10^{-2} - 10^{-3} M EDTA, DTPA at different pH value of the solution, which can be directly used for biomedical research, was shown.

Tandem-generator systems using two ion-exchange columns connected in series were developed. These systems allow for remote isolation of short-lived daughter from more long-lived parent radionuclides and to transfer short-lived radionuclides into another chemical forms avoiding time-consuming processes such as evaporation of highly radioactive solutions. Tandem-generator system is easy to automate and reduce thus time of the isolation of short-lived radionuclides, as well as the amount of radioactive waste.

**ELECTROPHILIC AND NUCLEOPHILIC FLUORINATION OF
[¹⁸F]NS18334**

**A.K. Kirjavainen¹⁾, S. Forsback¹⁾, P. Marjamäki²⁾, M. Haaparanta-Solin²⁾,
D. Peters³⁾, O. Solin^{1,4)}**

*1) - Radiopharmaceutical Chemistry Laboratory, Turku PET Centre,
University of Turku, Turku, Finland*

*2) - Preclinical Imaging Laboratory, Turku PET Centre, University of Turku,
Turku, Finland*

3) - DanPET AB, Malmö, Sweden

4) - Accelerator Laboratory, Åbo Akademi University, Turku, Finland

In this work we present the ¹⁸F-radiofluorination of 2-[¹⁸F]fluoro-6-((2,2,6,6-tetramethylpiperidin-4-yl)oxy)pyridine ([¹⁸F]NS18334) using both electrophilic and nucleophilic methods. [¹⁸F]NS18334 is a novel ¹⁸F-labelled norepinephrine transporter tracer for PET-imaging.

[¹⁸F]NS18334 was synthesized through electrophilic substitution using stannylated precursor and [¹⁸F]F₂ [1] or [¹⁸F]Selectfluor [2] as radiolabelling agent or through nucleophilic substitution using a brominated precursor. With all methods, the protected ¹⁸F-labelled intermediate was purified by radio-HPLC. The chemical and radiochemical purity of the protected intermediate were analyzed using radio-HPLC. Protecting group was removed using trifluoroacetic acid.

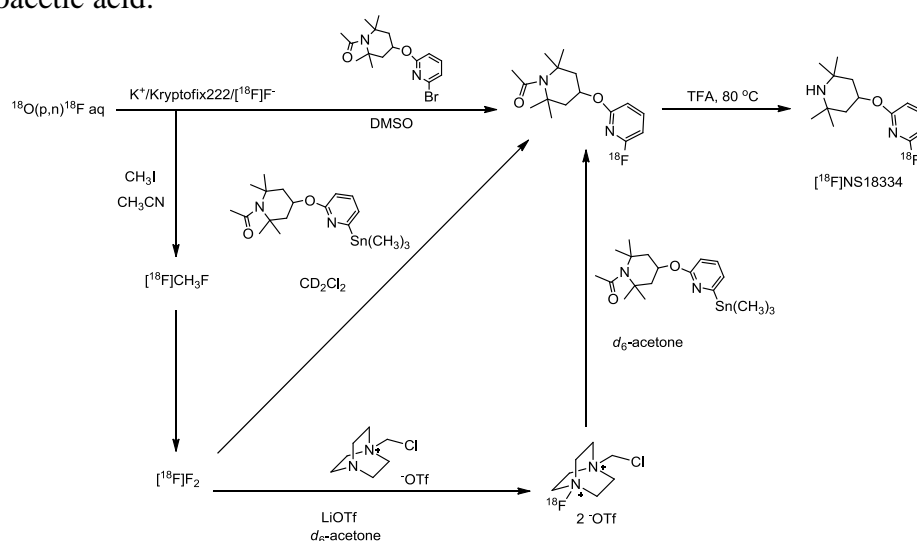

Fig. 1. Synthesis routes of protected [¹⁸F]NS18334.

The radiochemical yield with [¹⁸F]F₂ was 2.1 ± 1.5%, with [¹⁸F]Selectfluor 4.8 ± 2.4% and using nucleophilic labelling method 46.1 ± 4.8%. The radiochemical purity of the product was equal (>96%) with all methods.

We acknowledge the technical assistance of Jørgen Bach Pedersen and Tove Thomsen. This work was supported by the Academy of Finland (grant no. 116084, 128591 and 266891) and the Finnish Centre of Excellence in Molecular Imaging in Cardiovascular and Metabolic Research.

References

- [1] Bergman J, Solin O (1997) Nucl. Med. Biol., 24, 677-683.
[2] Teare H et al. (2010) Angew. Chem. Int., 49, 6821-6824.

PET IN RUSSIAN FEDERATION: STATE OF THE ART, TRENDS AND FUTURE PERSPECTIVES

R.N. Krasikova^{1,2)}

¹⁾ - *N.P.Bechtereva Institute of Human Brain, Russian Academy of Science (IHB RAS), 9, Pavlova str., St-Petersburg, Russia*

²⁾ - *St.-Petersburg State University, Department of Radiochemistry, 7-9, Universitetskaya nab., St.-Petersburg, Russia*

Positron Emission Tomography (PET) is one of the most sensitive and informative of non-invasive imaging tools in the portfolio of medical techniques that provide *in vivo* information about complex physiological and biochemical processes such as perfusion and metabolic rates, receptor and enzyme activity etc. Application of PET in Russia began in 1991 when first PET/cyclotron facility was established at the IHB RAS. Now the site is equipped with two PET-dedicated cyclotrons MC 17 (Scanditronix AB, Sweden, installed in 1991) and PETtrace 4 (GE Health Care, Uppsala, Sweden, installed in 2010) providing isotopes for radiotracer synthesis for both routine clinical application and research. After more than 20 years of application in St.-Petersburg and Moscow with proven clinical impact, especially in oncology, PET/CT was recognized by Russian Ministry of Health, Rosatom and Rosnano State corporations along with other government organizations as an the most significant imaging modality.

Due to increase of demand for PET examination in last few years several new cyclotron/PET facilities for large-scale clinical production of PET radiotracers have been established. They are usually located in and constitute part of the base infrastructure in regional oncological centres (Cheljabinsk, Magnitogorsk, Hanti-Mansisk, Chabarovsk, Kazan). Many other PET facilities are now in their planning stage or already receiving funding. The major issue here to be addressed is the fact that establishing a PET centre and, especially, setting up GMP production of radiotracers for clinical studies is a large-scale process. Typically in Russia the time frame from the conceptual stage to fully operational PET facilities is three to five years, with only a very few exceptions to the rule. Also, very often the newly established PET centers are geared towards the production of only one radiotracer - [¹⁸F]FDG, holding back full implementation of great possibilities of PET imaging technology. However, the previous and on-going research on the synthesis and automated technologies for well-known clinically useful radiopharmaceuticals and new PET radiotracers carried out at the IHB RAS and other PET centers may provide the basic research and educational platform that required for the effective application of PET in Russia.

The problem is that PET imaging is probably one of the most complex methodologies in medicinal imaging, requiring a great variety of integrated expertise in different fields - radiochemistry, biology, mathematics, bioorganic and medicinal chemistry, nuclear medicine, physics and computer science and also extensive technical support and logistics. The current lack of above-mentioned professionals both in numbers and experience is typical not only for Russia but for many other countries as well. One possible solution to this problem lies in an advanced practical training of professional radiochemists and radiopharmacists that has already been started at the “experienced” PET facilities. Relevant university programs have been recently introduced at St.-Petersburg State University as a part of master’s and bachelors education in radiochemistry department.

**RESEARCH OF THE POSSIBILITY OF TECNETIUM-99m
OBTAINING USING MOLYBDENUM OXIDES SAMPLES
IRRADIATED IN TRIGA MARK II LOW FLUX REACTOR**

A.V. Matyskin¹⁾, V.S. Skuridin²⁾

¹⁾ - Chalmers University of Technology, Department of Chemical and Biological Engineering, Energy and Materials Division, Sweden, S-412 96 Göteborg, matyskin@tpu.ru

²⁾ - Tomsk Polytechnic University, Institute of Physics and Technology, Research complex "Nuclear Reactor", Russia, 634062 Tomsk

The subject of this work was to research the possibility of ^{99m}Tc obtaining using low waste ⁹⁸Mo activation technology in low flux 250 kW TRIGA Mark II reactor (Vienna, Austria). Both natural and enriched in ⁹⁸Mo molybdenum oxides samples were compared. It was showed that ⁹⁸Mo(n, γ)⁹⁹Mo reaction effective cross section in central channel is 0,43 barn. The input of resonance neutrons into activation process is 61%. It was determined that after 120 hours of irradiation in central channel specific activity of natural and enriched MoO₃ will be 5 GBq/g and 16 GBq/g respectively. Extraction was chosen as the most concentrating technology to obtain ^{99m}Tc from such a low activity ⁹⁹Mo targets. The scheme of extractor is shown on the Fig. 1. It consists of two coaxial columns, internal (1) and external (2) which are connected to an air-vacuum system via branch pipes (5) and (6). The volumes of both columns are equal and separately exceed the volume of input targets. The internal column (1) has a contraction in the middle, a suction tube (4) at the top and a hole on the bottom through which the volumes of both columns communicate with each other. Multiple extraction of ^{99m}Tc is realized by alternative transfer of extracting agent and aqueous phase from one column to another with consequent phase immiscibility. Such transfer of liquids is reached by alternate vacuumization in columns through branch pipes (5) and (6). Intake of extracting agent is realized after transfer of both phases into column (1) and their complete stratification. Extractor construction provides self-regulation of interface level and it allows maintaining extractor in shielding container without any visual control. The expected activity of extracted ^{99m}Tc would be enough for one week work cycle (in case of natural targets) of diagnostic single crystal scintillation camera.

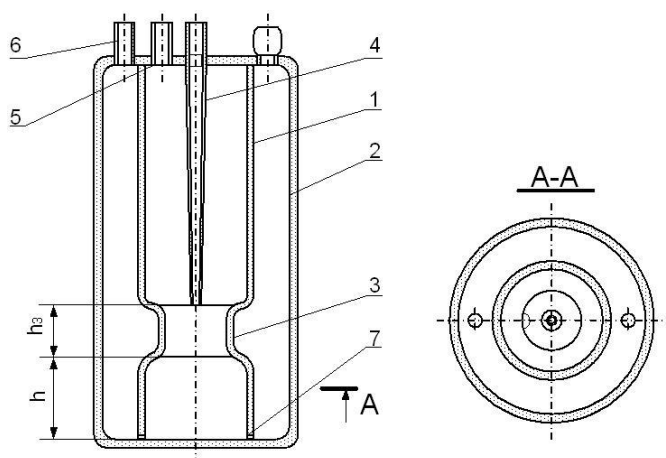

Fig. 1. Scheme of coaxial extractor in axial and cross section.

PREPARATION AND RADIOCHEMICAL SEPARATION ^{188}Re IN THE REACTOR IRT-T

V.G. Merkulov, E.V. Chibisov, V.V. Zukau, Yu.S. Maslennikov,
D.V. Kabanov, A.O. Pavlyuk

*Tomsk Polytechnic University, Russia, Tomsk, 30, Lenin Avenue,
chibisov@tpu.ru*

Rhenium-188, due to its radio-physical characteristics, finds a wide application in the therapy of various human illnesses in modern nuclear medicine. It is a generating radionuclide forming as a result of β^- -decay of Tungsten-188. At the same time, one should point out the complexity of obtaining ^{188}W at medium-stream reactors.

In the energy region of neutrons from 0.5 to 1,000 eV, there are wide resonance regions with high cross sections of nuclear reactions. The resonance integral of nuclides activation in nuclear reactions is 485 ± 15 barns and 2760 ± 550 barns correspondingly. Therefore, in the neutrons spectrum it is desirable to have as many resonance energy neutrons as possible. It is then that it becomes possible to use the medium-stream nuclear reactor for the purposes.

In order to confirm the possibility of producing mother radionuclide ^{188}W at medium-stream nuclear reactors in significant quantities, we carried out some calculations using the programs Geant4 taking into account various neutron-physical factors, influencing the speed of the radionuclide's accumulation in the target's material.

The numerical modeling was carried out using the Monte-Carlo method. The modeling procedure of neutrons passing in a substance represents the repeating process of launching an initial particle (neutron) with a set energy. After the particle has flown out of its initial state, i.e. out of the source of primary particles, and has had interaction within the volume of the irradiated sample, coordinates and energies of secondary particles are registered. The degree of the factor's influence depending on the neutrons' energy, chemical composition, and enrichment according to ^{186}W is evaluated.

We demonstrated the principle possibility of reaching the necessary level of accumulating mother radionuclide ^{188}W (~ 1 Ci at the irradiation of ~ 25 gr. of WO_3 of the natural isotope composition up to the specific activity of 0.05 Ci/gr.) in a medium-stream reactor. We also gave recommendations of how to form the irradiation area and the target configuration. To extract rhenium-188 was worked out a facility, based on the rhenium sublimation extraction from a low-active tungsten oxide with the natural isotope composition of a big mass of the initial WO_3 raw material with up to 25-26gr. For managing the process was created an automatic generator stand with a remote control. The generator stand consists of three basic blocks: a block of sublimation division of the generator pair $^{188}\text{W}/^{188}\text{Re}$; a block of the sublimate dissolving and spreading the rhenium-188 solution; and a block of opening and preparing the target. The block of oxygen production is auxiliary. The control and work management of the generator stand is carried out with the help of a processor using the program which includes seven commands. The radio-chemical yield of the target radionuclide rhenium-188 is up to 70%, the tungsten-188 constituent in the final product is lower than the limits of detection, the radio-chemical purity is more than 99.0%.

EFFECT OF PROTECTING GROUP ON THE RADIOCHEMICAL YIELD OF ^{18}F -FLUORINATED SUBSTITUTED BENZALDEHYDES

**V.V. Orlovskaja¹⁾, O.S. Fedorova¹⁾, D.M. Troushin¹⁾, V.I. Maleev²⁾,
T.F. Savelieva²⁾, Yu.N. Belokon²⁾, R.N. Krasikova¹⁾**

¹⁾ - *N.P. Bechtereva Institute of Human Brain, Russian Academy of Science, 9, Pavlova str., Russia*

²⁾ - *A.N. Nesmeyanov Institute of Organoelement Compounds, Moscow, Russia, vikaorl@list.ru*

Nucleophilic synthesis of ^{18}F -labeled amino acids (FAA) bearing fluorobenzyl moiety, such as 6- ^{18}F fluoro-L-dopa (FDOPA) and 2- ^{18}F fluoro-L-tyrosine (FTYR), proceeds via introduction of ^{18}F -label into the structure of benzaldehyde (BZ). During ^{18}F -displacement of a suitable leaving group in BZ the hydroxyl groups in the molecule need to be protected. Cleavage of the protective groups commonly used in a synthesis of FDOPA, 3,4-methylenedioxy or 3,4-methoxy is usually achieved by heating with 57% aqueous HI at 180-200°C for 20 minutes. The highly aggressive nature of HI leads to difficulties in automated production and can be problematic for the synthesis module. In order to circumvent this problem we introduced methoxymethoxy (MOM) as a protecting group that can be removed under mild reaction conditions (3M HCl, 60°C). As a model compound we have synthesized 6-nitro-3,4-bis-(methoxymethoxy)benzaldehyde (NO₂-MOM-BZ) in order to compare its ^{18}F -fluorination efficiency with a well-known fluorination substrate - 3,4-methylenedioxy nitrobenzaldehyde (nitropiperonal (**I**)).

The ^{18}F -incorporation rate into (**I**) (evaluated by radioTLC) was 90±3% (n=20) when reaction was carried out in DMF at 140°C for 10 min in the presence of kryptofix/carbonate. Under similar conditions fluorination efficiency of NO₂-MOM-BZ was in the range of 38-68% (n=7). Using DMSO and 18-crown-6 as a phase transfer catalyst did not improve the fluorination yield for NO₂-MOM-BZ. Additionally, we have investigated the ^{18}F -fluorination of 6-fluoro-3,4-bis-(methoxymethoxy)benzaldehyde (F-MOM-BZ), considering fluorine-19 to be a more effective leaving group. The reaction in DMF under similar conditions has resulted in poor fluorine-18 incorporation rates (6-14%). The highest radiochemical yield (42%) was obtained in fluorination mediated by 18-crown-6 in DMSO at 140°C.

To our knowledge the effect of protecting groups on the ^{18}F -fluorination efficiency of aromatic substrates was not systematically investigated before. According to our data the introduction of the MOM protecting groups into nitro BZ lowers the rate of fluorine-18 incorporation. However with the new generation of ^{18}F -targets the yield of the radionuclide from target is high enough to warrant proceeding with FDOPA synthesis at current incorporation yields.

Preliminary experiments in asymmetric nucleophilic synthesis of FDOPA using earlier developed method (*Krasikova et al., J. Label. Compds. Radiopharm., 1999*), but starting with NO₂-MOM-BZ, has shown that the MOM protecting groups can be removed under very mild conditions - 3M HCL at 60-100°C for 5 min. We propose that the use of BZ with MOM protecting groups can lead to substantial improvement in the automation of the synthesis procedures for the FAA. This study was supported in part by Russian Foundation of basic Researches, project 11-04-92010/13.

SEPARATION AND PRECONCENTRATION OF ACTINIDES AND RARE EARTH ELEMENTS BY EXTRACTION CHROMATOGRAPHY

**V.S. Ostapenko¹⁾, A.N. Vasiliev¹⁾, E.V. Lapshina²⁾, S.V. Ermolaev²⁾,
S.N. Kalmykov¹⁾, R.A. Aliev¹⁾**

¹⁾ - *Lomonosov Moscow State University, Leninskie gory, Moscow, 119992, Russia, ostapenkochem@gmail.com*

²⁾ - *Institute for Nuclear Research of Russian Academy of Sciences, 60th October Anniversary Prospect, 7A, Moscow, 117312, Russia*

Extraction chromatography is a technique that is well suited for the separation of radionuclides from various samples. This technique combines the selectivity of liquid-liquid extraction with the ease of operation of column chromatography.

α -Emitters, such as ²²⁵Ac and ²²³Ra, may be produced from irradiated thorium. These radionuclides are used for nuclear medicine. When irradiating thorium with medium-energy protons (100-200 MeV) a great number of spallation and fission products are formed. Radiochemical separation of actinides and rare earth elements is a very difficult task. For this aim we used extraction chromatography resins by TrisKem International company: TEVA (mixture of trioctyl and tridecyl methyl ammonium chloride as an extracting phase), DGA (N,N,N',N'-tetraoctyldiglicolamide), LN (di(2-ethylhexyl)orthophosphoric acid) and TRU (octylphenyl-N,N-di-isobutyl carbomoylphosphine oxide).

TEVA resin is proposed for sorption of Th. The distribution coefficient (k') for Th(IV) increases with HNO₃ concentration up to 400 in 6 M HNO₃. The value of Th sorption capacity is 70 mg/g (manufacturer's data), whereas the sorption of trivalent ions is negligible.

DGA and LN resins have a steep dependence of k' for trivalent ions on HNO₃ concentration. k' (DGA) reaches maximum in 6-7 M HNO₃ solution and drops down to 1-2 in 10⁻² M HNO₃ solution. k' (LN) demonstrates inverse acidity dependence [1, 2]. We used these resins to adsorb actinium and rare earth elements from HNO₃ solution of favorable acidity, while mono- and divalent ions (Cs⁺, Ra²⁺, Ba²⁺, Sr²⁺) as well as most of Ru, Zr, Nb, and others were washed out of the column.

TRU resin displays a moderate k' values $\sim 10^2$ for trivalent ions in the range of 1-5 M HNO₃ [2]. Optimization of acidity and column length allowed us to separate actinium from lanthanides.

Distribution coefficients of ²²⁵Ac on DGA, Ln, TRU – resins in nitric acids solutions with various concentrations were studied.

[1] D.R. McAlister., E.P. Horwitz, Solvent Extraction and Ion Exchange, 2007, V.25, P.757-769.

[2] E.P. Horwitz, D.R. McAlister, A.H. Bond, R.E. Barrans, Solvent Extraction and Ion Exchange, 2005, V.23, P.319-344.

**STATUS OF THE RADIO ISOTOPE COMPLEX RIC-80
(RADIO ISOTOPES AT CYCLOTRON C-80) AT PNPI**

**V.N. Panteleev¹⁾, A.E. Barzakh¹⁾, L.Kh. Batist¹⁾, D.V. Fedorov¹⁾,
A.M. Filatova¹⁾, K.A. Mezilev¹⁾, P.L. Molkanov¹⁾, F.V. Moroz¹⁾,
S.Yu. Orlov¹⁾, Yu.M. Volkov¹⁾, E.K. Dyakov²⁾, I.B. Savvatimova²⁾,
A.A. Yaskolko²⁾**

¹⁾ - PNPI NRC KI, 188300 Gatchina, Leningrad district, Russia

*²⁾ - FSUE SRI "LUCH", 142100 Geleznodorognaya str. 24, Podolsk Moscow
district, Russia*

vnp@pnpi.spb.ru

It is well known that cyclotrons play a very important role in the production of radionuclides for medicine. The cyclotrons are very reliable and safe installations. It is very important that from a very large set of different radionuclides produced with cyclotrons it is possible to select a lot of ones with appropriate nuclear-physics characteristics for medical use and the amount of these nuclides is much larger than produced for this purpose with the reactors. At PNPI (Petersburg Nuclear Physics Institute) a high current cyclotron C-80 with the energy of extracted proton beam of 40-80 MeV and the proton current up to 200 μ A is under construction. Its operation is planned to start at the end of 2013. Recently the project of radioisotope complex RIC-80 (Radio Isotopes at the cyclotron C-80) at the beam of the C-80 has been developed. The main goal of RIC-80 is production of a wide spectrum of radionuclides for diagnostics and therapy. Among them are the isotope-generators ^{68}Ge , ^{82}Sr , ^{81}Rb , pharmaceuticals on the base of ^{111}In , $^{123,124}\text{I}$, ^{223}Ra and many others. In the presented talk the project of RIC-80 complex with three target stations for isotope production is discussed. The peculiarity of the proposed radioisotope facility consists in the use at one of the target station the mass-separator with the target-ion source device for on-line or semi on-line production of a high purity separated radioisotope beams. The results of development of the target prototypes for production of different medical radionuclides are presented as well.

MODULAR NANOTRANSPORTERS FOR NUCLEAR DELIVERY OF ANTI-CANCER RADIONUCLIDES AND PHOTSENSITIZERS

A.A. Rosenkranz^{1,2)}, T.A. Slastnikova¹⁾, M.R. Zalutsky³⁾, A.S. Sobolev^{1,2)}

¹⁾ - *Institute of Gene Biology RAS, 34/5 Vavilov St., Moscow, 119334, Russia*

²⁾ - *Moscow State University, 1-12, Leninskiye Gory, Moscow, 119991, Russia*

³⁾ - *Duke University Medical Center, Durham, North Carolina 27710, USA*

A delivery system that could efficiently reach tumor, engage receptors on the cancer cell surface and transport its payload to the cell nucleus would be attractive for maximizing both the specificity and effectiveness of tumor treatment. We [1] created modular nanotransporters (MNT) that are polypeptides containing at least four moieties: a) an internalizable ligand to provide target cell recognition and receptor mediated endocytosis by the cell, b) an endosomolytic module to facilitate escape from endosomes, c) a nuclear localization sequence to allow active transport into the cell nucleus, and d) a carrier domain. MNT can increase *in vitro* cytotoxicity of photosensitizers [2] and emitters of Auger electrons [3] and α -particles [4] up to a factor of 3,000. MNT selectively accumulate *in vivo* in cancer cells, with the highest concentration in cell nuclei. Importantly, MNT mediated delivery of photosensitizers resulted in more than 90% longer tumor growth delay and significantly prolonged survival compared with free drug, while producing few if any side effects [5]. Moreover, MNT can deliver a wide spectrum of substances; they possess low toxicity and low immunogenicity in mice; their production and purification is simple and cost effective; it is possible to replace MNT modules to exploit different molecular and subcellular targets and to freeze-dry MNT for prolonged storage.

References

- [1] Sobolev A.S. Herald of the Russian Academy of Sciences, 2013, 83, 324.
- [2] Gilyazova D. G. et al. Cancer Res., 2006, 61, 10534.
- [3] Slastnikova T. A. et al. Eur. J. Nuc. Med. Mol. Imag. Res., 2012, 2, 59.
- [4] Rosenkranz A.A. et al. Int. J. Rad. Oncol. Biol. Phys., 2008, 72, 193.
- [5] Slastnikova T.A. et al. Int. J. Nanomed., 2012, 7, 467.

¹⁸F-FLUOROALKYLATED ANALOGUES OF ORM-13070 FOR PET IMAGING OF α_{2C} -ADRENOCEPTORS IN THE BRAIN

V. Stepanov¹⁾, R.N. Krasikova^{1,2)}, S.J. Finnema¹⁾, J. Sallinen³⁾, P. Holm³⁾, O. Solin⁴⁾, C. Halldin¹⁾

¹⁾ - *Department of Clinical Neuroscience, Karolinska Institutet, Stockholm, Sweden*

²⁾ - *N.P.Bechtereva Institute of Human Brain, Russian Academy of Science, St-Petersburg, Russia*

³⁾ – *OrionPharma R&D, Orion Corp.*

⁴⁾ - *Turku PETCentre, University of Turku, Turku University Hospital and Åbo Akademi University; e-mail: raisa.krasikova@ki.se*

Very recently [¹¹C]ORM-13070 was introduced as the first radioligand (1) [Arponen, E., et al., *Neuroimage*, 2010. 52: p. S125] for imaging of central α_{2C} -adrenoceptors. Evaluation in both pre-clinical and clinical settings however indicate, very fast receptor kinetics and a potential formation of a radioactive metabolite entering the brain; which could both be limiting factors in quantification of target receptors. Due to the longer half-life of ¹⁸F (110 min vs 20.4 min for ¹¹C) introducing an ¹⁸F-label to create a fluorine-18 analog of [¹¹C]ORM-13070 may give some advantages for imaging at later time-points and facilitate use of a bolus infusion (BI) approach. Also the lower energy of emitting positrons (0.65 MeV) enables quantitative imaging with higher spatial resolution.

In this work we have developed synthesis procedure for two deuterated fluoroalkyl analogues of (1), [¹⁸F]fluoromethyl-ORM-d2 (2) and [¹⁸F]fluoroethyl-ORM-d4 (3) for evaluation in preclinical studies in rhesus monkeys. The radioligands were prepared by two-step *O*-alkylation of the desmethyl-precursor, ORM-0013333, using deuterated [¹⁸F]fluoromethyl or [¹⁸F]fluoroethyl bromide. These labeling synthons were produced using standard Kryptofix_{2.2.2}-mediated fluorination of dibromomethane-d2 (25 μ l) or TosCD₂CD₂Br (5 μ l) as starting material. ¹⁸F-synthon generation was performed in acetonitrile (1 ml, 10 min, 100-110°C) and dichlorobenzene (0.7 ml, 10 min, 135°C) for methyl and ethyl derivatives, correspondingly. The alkylation was carried out in DMF for 5 min at 120-130°C. From several bases being investigated, the optimal alkylation yields were obtained using 3 M NaOH (4 μ l) for (2) and 0.5 M TBAH (4 μ l) for (3). Both radiotracers were purified by semi-preparative HPLC on a XBridge C18 column (250x10 mm) and MeCN/0.1 M NH₄CO₂ 45:55 as a mobile phase, concentrated on Oasis HLB and eluted with 1.0 ml of EtOH for a final formulation into 10-12 ml of PBS buffer. About 500 to 600 MBq of each radioligand was obtained from 15 min/35 μ A irradiation, with 90 min synthesis time. Radiochemical purity was in excess of 99%, with specific radioactivity in excess of 3000 Ci/mmol.

We compared the binding of the novel radioligands 2 and 3 with the reference 1 in one cynomolgus monkey. After i.v. injection of ~150 MBq of each of the radioligands the concentration of radioactivity in brain peaked within 5 min. The regional distribution was in accordance with the known distribution of the α_{2C} -adrenoceptors, with highest binding in the striatum and lower binding in the neocortex and cerebellum. The maximum striatum to cerebellum binding ratios were ~0.8 for 1, 0.4 for 2 and 0.5 for 3, respectively. The observed radiometabolites in plasma were more polar than the parent radioligands.

It can thus be concluded that 2 and 3 were successfully synthesized and require further evaluation in the nonhuman primate brain.

**SSC RF – IPPE RADIOISOTOPE PRODUCTION FOR NUCLEAR
MEDICINE**

D.V. Stepchenkov, N.A. Nerozin, E.V. Sulim, A.A. Semenova

*State Scientific Centre of the Russian Federation – Institute for Physics and
Power Engineering named after A.I. Leypunsky
Bondarenko Sq., 1, Obninsk, Kaluga Region, 249033, Russia
E-mail: dvstep@ippe.ru*

Since 1989 FSUE SSC RF – IPEE is a developer and producer of radioisotope products for medicine in Russia. Within this period millions of Russians passed through the diagnostics with the use of radiopharmaceuticals based on Tc-99m, generator-produced radionuclide, thousands patients have got treatment with the use of radiopharmaceutical “Strontium-89 Chloride”. During the 23-years production experience the isotope product quality has reached the best Russian level. Today a quality management system is applied in SSC RF – IPPE radioisotope production, patented technologies are under implementation, existing production sites are under modification in accordance with the requirements of State Standard P 52 249-2009 “Rules of arrangement of production and quality control of medicinal products” (GMP). Reconstruction of production allows provide the competitiveness of Tc-99m generators on Russian level and entry into the world market.

The results of the product production technology improvement (Tc-99m generators and radiopharmaceuticals based on Sr-89, Tl-201, Ga-67, P-32) are presented as well as scientific development of new radioisotope medical products: $^{188}\text{W}/^{188}\text{Re}$ chromatographic generator.

A POTENTIAL FOR PRODUCTION MEDICAL RADIONUCLIDES IN RUSSIA

B.L. Zhuikov

*Institute for Nuclear Research of RAS,
60th October Anniversary, 7A, Moscow, 117312, RUSSIA, bz@inr.ru*

Production of isotopes for medical diagnostics and therapy in Russia is located in several institutions based on big nuclear facilities all over the country. These facilities were earlier used for weapon and fundamental research. Most of isotopes are produced for export needs. But future growing consumption in Russia is anticipated for needs of national nuclear medicine.

New installations provide growing of production “fission” ^{99}Mo at nuclear reactors of the Research Institute of Atomic Reactors (Dimitrovgrad) and Karpov Institute of Physical Chemistry (Obninsk branch). It is also prospective producing ^{82}Sr , $^{117\text{m}}\text{Sn}$ and ^{225}Ac at linear accelerator of the Institute for Nuclear Research (Troitsk) (INR) followed by recovery pure products at the Institute for Physics and Power Engineering (Obninsk) and Karpov Institute of Physical Chemistry (Obninsk branch) with new effective radiochemical technologies. Also very successful are developments of $^{68}\text{Ge}/^{68}\text{Ga}$ -generator at CYCLOTRON Co. and $^{82}\text{Sr}/^{82}\text{Rb}$ -generator at INR together with Russian National Center of Radiology and Surgery Technologies (St. Petersburg) for PET-diagnostics.

This progress will result supplying a big fracture of medical isotopes in the world market. Collaboration with North American and European companies and laboratories plays an important role in the developments and production. The following problems are to be solved in order to provide a good progress in isotope production in Russia:

- to overcome agency barriers in the disposition of funds for R&D;
- to provide sufficient governmental funding to establish new facilities or to upgrade the existing facilities;
- to form a qualified and independent international committee for the distribution of funds to create and realize isotope projects;
- to improve the transportation logistics system;
- to reduce bureaucratic regulations (without prejudice to safety and security);
- to prepare highly qualified specialists; and
- to organize efficient international collaboration.

[1] B.L. Zhuikov. Production of medical radionuclides in Russia. A review. *Appl. Rad. Isot.*, 2103 (in press).

[2] B.L. Zhuikov. Isotope production at the Institute for Nuclear Research, Russian Academy of Sciences” current status and prospects. *Physics – Uspekhi*, 2011, v. 54, p. 968. There is a 1 page limit for the abstract, including figures, tables etc.

SOLID PHASE RADIOFLUORINATION FOR DOSE-ON-DEMAND PET

F.A. Zhuravlev, B. Mathiessen
Hevesy Laboratory, Technical University of Denmark, Frederiksborgvej 399, 4000 Roskilde, Denmark, fezh@dtu.dk

Objectives: Our research program is directed towards the development of efficient solid phase radiofluorination platform suitable for use in the next generation of cost effective dose-on-demand PET biomarker generators. Hereto we report the first example of simple, efficient and reusable solid phase radiofluorination media based on polymer supported phosphazenes.

Methods: Cyclotron-irradiated [^{18}O]water was passed through a small column packed with polymer supported phosphazenes, resulting in a quantitative (95-100%) trapping of [^{18}F]fluoride. After removal of residual water from the column by rinsing it with acetonitrile, a solution of a substrate was passed through the column yielding the desired radiofluorination product (Figure 1, left). The products were analyzed by standard analytical and radioanalytical equipment.

Results: A commercially available polystyrene-supported phosphazene PS-P₂^{tBu} (non-swelling, Fig. 1, middle) and our own synthesized PS-PEG-P₂^{Bz} (Fig. 1 right, swelling) showed excellent trapping and radiofluorination properties. The radiolabelling was typically carried out at 85-100 °C in acetonitrile. Both the aliphatic and aromatic substrates were reactive. [^{18}F]FDG and [^{18}F]FLT were successfully synthesized (Table 1).

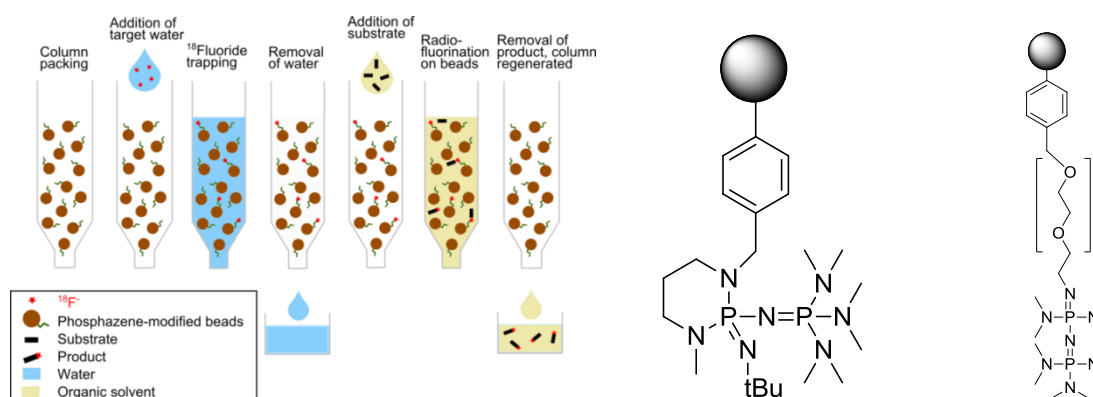

Fig. 1. On-column radiofluorination (left) and the structures of PS-P₂^{tBu} (middle) and PS-PEG-P₂^{Bz} (right).

Table 1. Substrate scope

Entry	Substrate	Trapping (%)	RCP (%)	RCY (%)	Entry	Substrate	Trapping (%)	RCP (%)	RCY (%)
1		99	97	51	4		95	93	42
2		99	99	52	5		95	67	16
3		100	65	7	6		100	60	23

**EXPERIMENTAL INSTALLATION AT IRT-T OF TPU
FOR IODINE-125 PREPARATION**

V.V. Zukau, G.G. Glukhov, Yu.N. Adishev

*Institute of Physics and Technology of National research Tomsk Polytechnic
University, Russia, Tomsk, Lenin Av, 30, lab31radcontrol@rambler.ru*

Isotopes of iodine such as ^{125}I , ^{131}I and ^{132}I have been widely applied in medicine, particularly for diagnostics and treatment of various diseases (for example, brachytherapy). P. Harper and D. Warren and other authors insist on more efficient use of ^{125}I for medical purposes in comparison with ^{131}I or ^{132}I . The advantages are explained by certain properties of ^{125}I . Its half-life is about 60 days. It decays due to electron capture and release of low energy gamma quanta (28-33 keV). Thus radioactive tissue destruction occurs only around the pharmaceutical ampoule and the total dose for the patient is not high whereas other iodine isotopes are characterized by the release of gamma quanta with significant energy.

Preparation of pharmaceuticals on the basis of ^{125}I starts as far back as the 60th of the XX century. It was the accelerator based method. ^{125}I produced in this way was polluted by other radioactive iodine isotopes such as ^{124}I or ^{126}I . It influenced the quality of the pharmaceuticals, thus the method did not become popular and wide-spread. The main idea was the chain of nuclear reactions

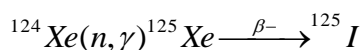

The main method of iodine production is Xe irradiation in the container. The pharmaceutical contains 1% of ^{126}I and less than 0.1% of other admixtures.

The method that is suggested by the authors is based on the loop alternative method when produced ^{125}I is removed from the irradiation zone. To prevent ^{125}I sorption on the walls of the installation methane is supplied into the system

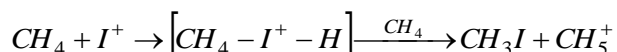

The final products have quite less capability to be absorbed by the walls of the installation.

To research the dynamics of ^{125}I concentration the scheme and construction of automatic experimental installation at IRT-T of Tomsk Polytechnic University for preparation of ^{125}I radiopharmaceutical were designed. The software for installation operation control with data information transfer to the PC monitor in real-time mode was developed.

4. Environmental Radioactivity and Radioecology

**RADIOECOLOGICAL EXPERT EXAMINATION OF THE
CHEMISTRY DEPARTMENT AND BOTANICAL GARDEN
TERRITORIES OF M.V.LOMONOSOV MOSCOW STATE
UNIVERSITY**

A.A. Abramov, S.V. Volkova, A.V. Agaeva, S.Yu. Yegorov, G.A. Zaikin

*M.V.Lomonosov Moscow State University, Chemistry Department, Moscow,
Russia, e-mail: aaa2745@yandex.ru*

Radioactivity and ionizing radiation existed on Earth much time before the appearance of life. Natural radiation background is the integral factor of environment that is resulted from the cosmic radiation, radioactivity of soil, water, air, plants, animals, i.e., from everything that surrounds us, as well as from man-caused and medical sources.

Due to recommendations of UNSCENR (United Nations Scientific Committee on the Effects of Nuclear Radiation), there should be the permanent refinement of the natural radiation background level and determination of factors that influence its changes. To follow these recommendations, corresponding investigations should be carried out on the local scale taking into account local specific features.

In our work, the following radiation- epidemiologic inspections were carried out:

1. All territories of the Chemistry Department and Botanical Garden were subjected to the complete examination by “listening” or pedestrian “gamma-photography” using handheld radiometer-dosimeter SRP-68-01. The aim of this examination was to find and localize possible radioactive anomalies. The exposure rate (ER) was measured in 580 points of reference using MKS-AT-1117M devise.
2. We analyzed 430 soil samples for determination of specific activity in them of natural radioactive nuclides ^{40}K , ^{226}Ra , ^{232}Th and man-caused cesium-137.
3. Measurements of specific activity of radioactive nuclides were carried out by the method of γ -spectrometry using Ortec® DSPEC jr 2,0™ spectrometer. The data obtained were used in calculations of the effective activity of mixtures of natural radioactive nuclides. The calculated values did not exceed standard values. Specific activity of man-caused cesium-137 did not exceed reference values.
4. We determined radon-222 flux density (RFD) on the earth surface of the territory under examination. Determination of RFD was carried out using “Kamera 01” by measuring radon concentration through the β -radiation of Rn-222 decay products. For the radon sorption, we used storage columns with the activated carbon. We found anomalous RFD values in the several points of reference. Now, we carry out the monitoring of RFD values in these points considering the influence on RFD of seasonal temperature changes in the environment, air humidity and atmospheric precipitation.

Data on ER, RFD and specific activity of radioactive nuclides were subjected to the statistical treatment. It was shown that excluding separate anomalous values, fluctuations of the determined parameters were close to the normal distribution.

COMPARATIVE EVALUATION OF THE BIOAVAILABILITY OF URANIUM AND ARTIFICIAL RADIONUCLIDES IN THE ECOSYSTEM OF THE YENISEI RIVER BASIN

A. Bolsunovsky, M. Medvedeva

Institute of Biophysics SB RAS, Krasnoyarsk, Russia, radecol@ibp.ru

The Yenisei River is one of the largest rivers in the world, which had been subjected to radioactive contamination for over 50 years, due to operation of the Mining-and-Chemical Combine (MCC) of Rosatom at Zheleznogorsk, which had been producing weapons-grade plutonium. Bottom sediments and floodplain of the Yenisei River are contaminated by artificial radionuclides, including transuranium ones, both close to the MCC and at a considerable distance downstream. The MCC is also a source of uranium isotopes in the Yenisei. Thus, the Yenisei River basin is a unique environment for studying mobility of both uranium isotopes and artificial radionuclides in all components of the aquatic ecosystem. The purpose of this study was to compare the degrees of bioavailability of uranium and artificial radionuclides in the ecosystem of the Yenisei River basin.

Samples of water, sediments, and aquatic organisms were used as study material. Aquatic organisms were represented by submerged plants, benthic-feeding fish, and zoobenthos. The submerged plants (macrophytes) analyzed were of three species: *Fontinalis antipyretica*, *Potamogeton lucens*, and *Myriophyllum spicatum*. Grayling (*Timalus arcticus*) represented benthic-feeding fish, and zoobenthos species were represented by *Philolimnogammarus viridis*, which forms the major part of the grayling's diet. Samples were collected at positions in the vicinity of the MCC discharge point, at a distance of 110 km downstream of Krasnoyarsk, and upstream of the MCC during sampling campaigns in 2006-2011. Radionuclide measurements were performed using a wide range of instrumental methods: gamma-spectrometry with a "Canberra" spectrometer (U.S.), mass spectrometry with an "Agilent" spectrometer (U.S.), neutron activation analysis, and beta-alpha radiometry.

The results obtained in this study suggest that the part of the Yenisei River ecosystem contaminated due to MCC radioactive discharges contains both artificial radionuclides and elevated levels of uranium. Submerged plants accumulated the highest activities of both artificial radionuclides and uranium compared to other aquatic organisms analyzed in this study. The highest uranium concentrations were detected in the biomass of aquatic moss (*Fontinalis antipyretica*), and in some samples the uranium concentration factor was higher than the concentration factors of some artificial radionuclides. *Philolimnogammarus* and grayling collected close to the MCC contained a smaller number of radionuclides, and the activities of these radionuclides, including uranium, were lower than in macrophytes. Uranium concentrations in the grayling differed among its parts (muscles, bones, head, gills, etc.). As determined by sequential chemical extraction, the mobility of uranium in Yenisei sediments was higher than the mobility of ^{137}Cs and ^{60}Co . Thus, uranium has higher mobility and bioavailability than other radionuclides in the Yenisei River ecosystem.

RADIONUCLIDES IN THE KOLA PENINSULAS' GEOSYSTEMS

A.V. Evseev, A.D. Telekova, N.B. Sedova

Lomonosov Moscow State University, Department of Geography

Nowadays, much attention is paid to the research of accumulation and transference of radionuclides. The Kola Peninsula is a region with high pollution level, including radioactive contamination, caused by large concentration of functioning and potential sources of pollution. There are many nuclear reactors situated in that area, especially on the naval bases with nuclear submarines at the north coast. Moreover, there is a problem of burying radioactive waste.

Our research of the problem of soil and vegetation pollution by radionuclides in the Kola Peninsula was aimed at identifying the main features of their migration and accumulation in the landscapes of tundra, forest tundra and Northern taiga. The main research task was to identify correlations of the distribution, migration and concentration of technogenic radioactive isotopes and stable pollutants in natural landscapes with the intention of using these data to assess the effects of radiation of objects on the natural environment. The scientific basis of solving this problem is the theory of geochemical landscapes and doctrine of geochemical barriers. The terms of transfer and accumulation of pollutants are consistently analyzed on the scale of a particular enterprise, production site and its surrounding territories, being contaminated. There is a regional landscape-geochemical analysis and zoning being held in the Kola region. Our researches showed that the main part of mosses and lichens contains Cs137 within 30-80 Bq/kg and only in some cases there were concentrations of less than 10 Bq/kg and more than 100 Bq/kg. The maximum concentration detected, was 179 Bq/kg, which had been discovered in the Central part of the Kola Peninsula. The spatial distribution of radionuclides in the soil depends on the number shown on the surface and on the migration speed. The concentration maximum for all the considered soils was recorded in the upper organogenic horizons, and the content of Cs137 was in the range from 20 to 70 Bq/kg. The main characteristic of soils is sharp decrease in the concentration of Cs137 as deepening. The maximum level of concentration the Cs137 in the soil reached a point of 270 Bq/kg in the upper humus horizon of illuvial-glandular podzolic soil. In the lower B and C horizons, concentration of this radionuclide didn't transcend 10 Bq/kg. It shows the absence of radial migration in the soil profile and availability of a powerful geochemical barrier in the form of plant litter and humus horizon.

Special attention was given to the Khibiny Massif. We have carried out a study of region's radioecological state, where preserved at the present time mines are located – nuclear tests' locations of the JSC «Apatite». The analysis showed that the radioecological situation in the Khibiny Massif can be assessed as favorable. In the greater part of samples, the Cs-137 content fluctuates within the valid range of 6-60 Bq/kg. However, there are separate samples with abnormal concentrations up to 320 Bq/kg. The range of the natural radionuclides' content of radium and thorium is also high: from 0 to 250 Bq/kg, which is associated with high natural radioactivity of the Khibiny Massif.

The information obtained was compared with the territory, situated near the Kola NPP, which also conducted testing of the soil, vegetation and sediments, and where the values of average specific activity of Cs-137 made up 60-70 Bq/kg. During the study of radionuclides' distribution in natural landscapes it was found, that the upper bioorganic peat humus soil horizon and vegetation which has mainly atmospheric nutrition (lichens, mosses) are the most contaminated components among all elementary landscape units. The revealed levels of the average radionuclides' content in soils in a 50-kilometer zone around the objects are below the existing maximum permissible norms.

**RADIOACTIVE SAND ACCUMULATIONS ON THE BEACHES OF
THE WHITE SEA, THE BLACK SEA AND THE SEA OF AZOV**

**V.M. Fedoseev¹⁾, G.A. Safyanov¹⁾, V.S. Voloshin²⁾, I.N. Beckman¹⁾,
Yu.A. Sapozhnikov¹⁾, N.V. Shevchenko¹⁾, L.M. Shipilova¹⁾, Y.I. Lys¹⁾,
D.A. Minyaeva³⁾, G.B. Ryazantsev¹⁾**

¹⁾ – *Lomonosov Moscow State University, Leninskie Gory, 1 bld.10, Moscow
119991, Russia, anis-mgu@mail.ru*

²⁾ – *Azov State Technical University*

³⁾ – *Mendeleyev University of Chemical Technology of Russia*

This year marks the 150th anniversary of the birth of Vladimir Ivanovich Vernadsky. V.I. Vernadsky was one of the first to understand the great importance of the study of radioactive processes for all aspects of society. He pointed out that, of course, these works are to be carried out by different specialists, but they must be united by a unified leadership, and permanent research station should be organized. Azov Research Station (ANIS), a joint project of the Lomonosov Moscow State University (Russia) and the Azov State Technical University (Ukraine), has been carrying out research on the shores of the Sea of Azov, Black and White seas for 17 years. The priorities of the work of ANIS are: radio-ecological marine studies, geomorphology of coasts, marine geology. The natural hazard on some seashores are the so-called "black sands". Radioactive sands were formed by natural geological processes. The main radioactive elements in them are thorium-232, uranium-238 and their decay products. Gamma radiation levels in places of "black sand" accumulation are 50-300 microR/h on average, but may reach 900-1000 microR/h in different places during some years. Chemical, mineralogical and grain-size analyses of radioactive sand were carried out; also a gamma spectrometry, and analysis of their radioactive emanations. The dependence of the radiation background of the coast on the meteorological parameters was studied. There are many coastlines in the world which are known to have radioactive objects (India, Brazil, Sri Lanka, etc.), while the similar radioactive deposits of the White, Azov, and partly Black Seas are hardly described. Radioactive placers of the White Sea are not a serious environmental hazard due to the low population density and the absence of vacationists; while the uniqueness of the northern shores of the Black and Azov seas is not only in the existence of "black sand", but in superposition of several factors: the presence of radioactive sands, high population density and great number of vacationists, and a dry, strong wind. The absence of even one of these factors would remove the problem or, at least, make it irrelevant, but their joint presence creates a situation which is extremely dangerous and has no analogues. The Department of radiochemistry of Chemistry Faculty of Moscow State University was the initiator and main organizer of the ANIS; besides the Chemistry Faculty, other faculties take an active part in the work of the station at present. An Internet project SECOLOGY (www.secology.org) is created and maintained, which shows the location of potentially dangerous accumulations of monazite sands, with recommendations for the public and tourists. It is not possible to ignore the hazard of the "black sands". But it is not necessary to ban the whole coastline for public recreation, too. It is enough to detect all the localizations of black sands, to control them and to carry out protective measures. One must also bear in mind that not all the "black sands" of the seas are radioactive. The presence of radioactive sands is often confined to the crystalline arrays; as the White Sea sands are due to the Baltic Shield, and the sands of Azov are due to the Ukrainian crystalline shield. Each case of the detection of heavy dark marine placers requires a special study.

**RED-OX STATES OF URANIUM IN MINERALS BASED ON
CHEMICAL SHIFTS OF X-RAY LINES**

R. Gieré¹⁾, E.V. Puchkova²⁾, R.V. Bogdanov²⁾

¹⁾ – *Albert-Ludwigs University, 79104 Freiburg, Germany*
giere@uni-freiburg.de

²⁾ – *St. Petersburg State University, 199034, St. Petersburg, Russia*
bogdanov@RB7584.spb.edu

In the work, the oxidation state of Uranium has been studied in the two types of naturally occurring minerals: microlite and monazite. Microlite is a mineral of the pyrochlore group, its formula being $(Ca,Na)_2Ta_2O_6(O,OH,F)$. Its origin is from pegmatites of Africa. The content of Uranium in microlite is 1.3 ± 0.1 wt %. The two samples of monazite under study originated from pegmatites: monazite 1, from pegmatites of North Karelia, aged about 2 billion years; monazite 2, from pegmatites of China, aged about 1 billion years. The content of Uranium in monazite 2 is comparable with that of microlite, the content of Thorium being up to 8 wt%. The content of Uranium and Thorium in monazite 1 is lower than in monazite 2 by a factor of 3 to 3.5. Red-Ox states of Uranium were studied using the method of chemical shifts of $L\alpha_1$ - and $L\beta_1$ -emission X-ray lines [1]. From the relative content of Uranium species, the oxygen coefficients $K=2+x$ have been calculated. Microlite is characterized by the K value of 2.57 ± 0.01 . The oxygen coefficients of uranium in monazites are significantly lower: in monazite 1, $K=2.25$; in monazite 2, $K=2.15$. Despite the relatively low content of Uranium in microlite, the oxidation state of Uranium in this structure is substantially higher than in the structure of monazite. In the microlite structure, Uranium is predominantly in its penta- and hexavalent state. This result confirms the earlier conclusion made in [2] on the intensive processes of radiation-induced oxidation of Uranium and (supposedly as well) Np and Pu in the structure of pyrochlores. Uranium in monazites is less prone to oxidation. The reason is that autoradiolysis of the mineral does not lead to a metamict destruction of the crystal lattice. Radiation-induced damage and disorders in electronic- and atomic subsystems (sub-lattices) of the mineral are spontaneously annealed (cured) over short geological time period [3]. The structure of monazite allows isomorphous substitution for the (III)- and (IV)-valent f- and d-elements, e.g. Lanthanides, Thorium, and Uranium (IV). Upon oxidation of Uranium, or when the isomorphous capacity of monazite towards Uranium is exceeded, the structure of monazite rejects Uranium, which then has to be concentrated in the form of oxide in fractures and on inner surfaces of the mineral [4]. In the monazite samples under study, Uranium is present in the $U_{20}O_{43}$ and U_4O_9 oxide phases.

References

- [1] Yu.F. Batrakov, R.V. Bogdanov, E.V. Puchkova, et al. Radiochemistry (English Translation of Radiokhimiya), 2000, Vol. 42, № 2, pp. 106-112.
- [2] R.V. Bogdanov, Yu.F. Batrakov, E.V. Puchkova, et al. // Scientific Basis for Nuclear Waste Management, XXV. Ed.: B.P. McGrail, G.A. Cragolino. Boston, USA, 2002, pp. 295-301.
- [3] Y. Eyal, and R.L. Fleischer. Nature, 1985, Vol. 314, pp. 518-520.
- [4] A.N. Komarov, I.B. Berman, and T.V. Kol'tsova. Geokhimiya, 1985, No. 7, pp. 979-987 (in Russian).

**BEHAVIOR OF RADIONUCLIDES IN NATURAL ENVIRONMENT
OBJECTS IN THE IMPACT ZONE OF KRATON-3 UNDERGROUND
NUCLEAR EXPLOSION IN THE REPUBLIC OF SAKHA**

**T.A. Goryachenkova, I.E. Kazinskaya, E.A. Kuzovkina, V.S. Ryuleeva,
A.P. Novikov**

*Vernadsky Institute of Geochemistry and Analytical Chemistry, Russian
Academy of Sciences, Moscow, Russia, 119991, Kosygin 19
e-mail: goryach@geokhi.ru*

Underground nuclear explosions (UNE) were conducted on the territory of the Republic of Sakha (Yakutia) for economical purposes and military researches; this became the cause of a complex radiation environment in this region. Following the results of the research, it has been established that the UNE in Yakutia were conducted without taking into account the appropriate study of geological, cryosolic and hydrogeological conditions of the territory. The Kraton-3 emergency explosion, which was made in 1978 on the bank of the river Markha (left affluent of the river Vilyui), holds a special place.

Samples of soil, vegetation, river water and ground wells were collected in 2012 on the contaminated territory in the impact zone of Kraton-3 UNE. The soils were collected from a depth of 0-5 (vegetal bedding) and 5-10 cm. Moreover, a soil cross section was in the depth of 42 cm. Vegetation samples are represented by larch needles, sedge, moss and lichen.

The following methods were used for the determination of radionuclides (RN): ^{137}Cs was determined by a spectrometer directly in the air-dry samples; $^{239,240}\text{Pu}$, ^{90}Sr and ^{237}Np were recovered from one sample by boiling them with 7,5 M of HNO_3 in the presence of KBO_3 . Concentration and purification of $^{238-240}\text{Pu}$ was carried out on a chromatographic column filled with anionite VP-1A, ^{90}Sr was isolated using sorption with crown ether. The determination of ^{237}Np was carried out by the luminescent method.

Membrane filters with pore size 200 and 5 nm were used to study the links of RN in natural waters.

The content of RN in soils, in the impact zone of Kraton-3 UNE varies within wide limits. In the bedding (0-5) cm and in the soil layer 5-10 cm, the content of ^{137}Cs ranged from 500 to 18200 Bq/kg of ash and 26-6901 Bq/kg of air dry soil. In the bedding layers (0-5) and soil layers (5-10) 10-184 Bq/kg of ash and 4-127 Bq/kg of air-dry sample of $^{239,240}\text{Pu}$, respectively, were found. The ratio of isotopes $^{238}\text{Pu}/^{239,240}\text{Pu}$ is mostly 0,04-0,06, which is typical for global fallout. The content of ^{90}Sr in the bedding and soils is 153-8760 and 14-1500 Bq/kg, respectively. The content of ^{237}Np in soils is 2,5-5,0 Bq/kg.

Vertical distribution of RN in the profile of calcareous soil differs significantly. In the upper layer of soil (0-4 cm) 94,6% of ^{137}Cs , 91,0% of $^{239,240}\text{Pu}$, 48,7% of ^{90}Sr and 24,3% of ^{237}Np were found. In the layer of soil 4-8 cm, the content of all RN is lower than in the upper layer and equals to: 4,6%, 3,3%, 35,3% and 19,8% for ^{137}Cs , $^{239,240}\text{Pu}$, ^{90}Sr and ^{237}Np , respectively, which is indicative of more intensive vertical migration of ^{90}Sr and ^{237}Np compared to other RN. At the depth of 20-42 cm, the content of all the studied RN, except for ^{237}Np , does not exceed 0,5-2% of their deposit in the soil. In the bottom part of the soil crossover, the content of ^{237}Np amounts to 20%.

The link between $^{239,240}\text{Pu}$ and colloidal substances of water collected from the well laid in the impact zone of Kraton-3 UNE was studied. The main part of Pu (51,5%) is linked to the fraction of large colloids (> 200 nm), 46,3% of Pu was found in the colloid composition within the range of the size 200-5 nm, 2,2% of Pu - in regular solution (<5 nm).

Am(III) SORPTION ONTO TiO₂ AND NdPO₄

**N.N. Gracheva¹⁾, A.Yu. Romanchuk¹⁾, E.A. Smirnov¹⁾, A.V. Garshev¹⁾,
E.A. Shirshin¹⁾, K.I. Bryukhanova²⁾, K.S. Gavrichev²⁾, S.N. Kalmykov¹⁾**

¹⁾ - Lomonosov Moscow State University, Moscow, Russia, 119991

*²⁾ - Kurnakov Institute of General and Inorganic Chemistry of RAS, Moscow,
Russia
nadigra91@yandex.ru*

As a result of the activities of the nuclear fuel cycle enterprises accumulate large amounts of radioactive wastes that have to be transferred into the solid matrices (glass or mineral-like). Cesium and strontium fraction is mainly vitrified in borosilicate or alumophosphate glass. The content of alpha-emitting radionuclides such as Am(III) and Cm(III) is strictly regulated in liquid wastes since they may affect the long-term stability of glasses. Therefore one of the important tasks is to develop the methods for separation of these radionuclides from waste solutions send for vitrification. In this study Am(III) sorption onto titanium dioxide (TiO₂) and neodymium phosphate (NdPO₄) was investigated. These inorganic materials are promising for the separation of radionuclides and may be subsequently used as a matrix for the radioactive wastes.

The aim of this work is to determine the sorption behavior of Am(III) onto TiO₂ and NdPO₄ with different crystallinity, morphology and porosity as a function of pH, time, ionic strength and concentration of Am(III).

All sorbents were characterized by scanning electron microscopy (SEM), X-ray diffraction (XRD), BET technique and potentiometric titration. Measurements of radioactivity were carried out using liquid scintillation spectrometry and γ -spectrometry. In this work Am(III) sorption onto different samples of TiO₂ was studied. One sample was subjected to hydrothermal treatment, resulting in a change of crystallinity and pore size distribution. The pH edge of Am(III) sorption on a sample of TiO₂ after hydrothermal treatment is shifted to higher pH values that is in agreement with the values of the pH_{PZC} of samples. Sorption isotherms of Am(III) at pH 4.0 and 4.5 were obtained and fitted by Langmuir model. As a result, surface capacity of both samples of TiO₂ were determined. The sorption data was used to derive equilibrium constant of Am(III) sorption on the surface of both samples.

Am(III) sorption onto two samples of NdPO₄ with different morphology (bulk microcrystalline and whiskers) was studied. Investigation of Am(III) sorption kinetics onto NdPO₄ showed that steady state conditions were established fast in case of whiskers compared with bulk microcrystalline sample, whereas pH dependence of Am(III) sorption onto two samples of NdPO₄ are identical. No influence of background electrolyte solution (NaClO₄) on Am(III) sorption was showed, indicating the formation of innersphere complexes of Am(III).

To determine the speciation of americium on the surface of the solid phases, time resolved laser induced fluorescence spectroscopy (TRLIFS) was applied using Eu(III) as a chemical analog to Am(III). It was shown that Eu(III) sorption on the surface of both solids is described by formation of innersphere complexes. Using the decay kinetics, change in the number of water molecules in the Eu(III) coordination sphere was obtained.

**ENVIRONMENTAL IMPACTS OF FUKUSHIMA DAIICHI ACCIDENT
IN FINLAND – CHALLENGES OF STUK**

T.K. Ikaheimonen, P. Vesterbacka, A. Mattila, A.-P. Leppänen

***STUK – Radiation and Nuclear Safety Authority, P.O. Box 14, FI-00881
Helsinki, Finland, e-mail: Tarja.Ikaheimonen@stuk.fi***

Radiation and Nuclear Safety Authority (STUK) is regularly monitoring radioactivity in the environment in Finland.

In March 2011, the Fukushima nuclear accident spread radioactivity all over the northern hemisphere. In Finland, the first observations of the radioactivity originating from the Fukushima accident were made in the outside air on 20-21 March, over a week after the accident. Most atmospheric radioactive substances fell rapidly below the detection limits. Traces of Cs-134 were, however, still detected in some air samples as late as November-December 2011.

Increased radioactivity was also analyzed from the deposition samples. STUK collected samples weekly from March 2011 until the end of April 2011. In 2012, small amounts of Cs-137 and Cs-134 from the Fukushima accident were also found from the environmental samples. Cesium was found in, e.g., lichens, mosses, fungi, elk and reindeer meat. The results will be presented in this seminar.

Challenges of STUK as an authority in charge of environmental monitoring, and challenges of researches for detecting expertise as well as for communication with public during this event will also be discussed.

BEHAVIOUR OF SELENIUM IN GRANITIC ROCK

**J. Ikonen¹⁾, P. Sardini²⁾, M. Voutilainen¹⁾, K. Hänninen¹⁾, L. Jokelainen¹⁾,
R. Pehrman¹⁾, A. Martin³⁾, M. Siitari-Kauppi¹⁾**

*¹⁾ - Laboratory of Radiochemistry, University of Helsinki, A.I. Virtasen aukio
1, 00014 Helsingin yliopisto, Finland,
marja.sitari-kauppi@helsinki.fi*

*²⁾ - IC2MP, University of Poitiers, UMR 7285 CNRS, France,
paul.sardini@univ-poitiers.fr*

*³⁾ - Nagra (National Cooperative for the Disposal of Radioactive Waste),
Hardstrasse73, 5430 Wettingen, Switzerland, andrew.martin@nagra.ch*

In many countries, high-level radioactive waste is planned to be disposed of in deep-lying crystalline rock. For performance assessment and safety analysis of such repositories it is vital to determine properties linked to migration of nuclear elements in surrounding geosphere.

Diffusion and sorption of radionuclides have been studied extensively in the laboratory scale. However, only few long-term in situ experiments have been carried out to evaluate matrix diffusion and sorption properties of radionuclides. There is variation in distribution coefficients and diffusion coefficients as well as in porosity values depending whether the determinations are based on laboratory experiments or in situ experiments. In order to assess the relevance of laboratory experiments, the Swiss National Cooperative for Disposal of Radioactive Waste (Nagra) have been conducting extensive in situ experiments at the Grimsel test site (GTS) in the field of radionuclide transport and retention. In this experiment, radionuclides H-3, Na-22, Cs-134, Cl-36 and Ba-133 as well as nonradioactive element Se, are circulated in a packed-off interval.

In the Laboratory of Radiochemistry, University of Helsinki, there have been running two laboratory scale selenium diffusion experiments, which conducted in two rock blocks; Kuru grey granite and Grimsel granodiorite. Changes of the selenium concentration in the injection and observation holes are followed using ICP-MS technology. Experiments are conducted in oxic conditions. Parallel to the diffusion experiments, selenium sorption onto Grimsel granodiorite and Kuru grey granite was studied with batch experiments and geochemical modelling. Sorption was studied as a function of grain size, pH, Se concentration and p_e . These experiments were done with Se-75 and stable selenium in groundwater simulants.

Diffusion experiment has been running in the Kuru grey granite for three years and significant breakthrough of selenium is observed at a distance of 1 cm. Breakthrough has also been observed to 1 cm distance in Grimsel granodiorite within two years. Diffusion of selenium has been found to be faster in the direction of the foliation than against it.

RADIOECOLOGICAL CHARACTERISTICS OF ChNPP EXCLUSION ZONE AT THE LATE PHASE OF THE ACCIDENT

Yu.A. Ivanov

*University of Life and Environmental Sciences of Ukraine
Ukrainian Institute for Agricultural Radiology
Mashinostroiteley street, 7, u.s. Chabani, Kiev region, Ukraine, 08162.
ivanov@uiar.kiev.ua*

Attempt of consideration of ChNPP Exclusion zone (EZ) as a source of radionuclide redistribution both in the territory and outside of its borders is presented. General characteristics of EZ territory - geographical location; current structure of EZ territory as well as the presence on this territory a number of natural and man-caused objects are considered from point of view of radionuclide stocks and fluxes formation. Terrestrial (forest, meadow and fallow land) and water (rivers, lakes, swamps etc.) ecosystems; ChNPP, Object "Chelter", pond-cooler, points of radwaste disposal and points of temporary localization of radwaste etc. are among of mentioned above objects.

Characteristics and peculiarities of contamination of natural and man-caused objects of EZ with ^{90}Sr , ^{137}Cs and actinides are considered.

Specificity of the Zone territory as a source has been predetermined with heterogeneity of the territory contamination with various radionuclide, multiplicity of physical-chemical forms of fallout, mixed character of soil cover characteristics.

Well-defined heterogeneity of migratory medium (soil cover), plurality of physical-chemical forms of fallout predetermines: intensity of different radionuclide inclusion to biogeochemical chains of migration, plurality of radioecological situation types on the EZ territory, different parameters of long-term dynamics of radioecological situation, including long-term dynamics of ^{137}Cs and ^{90}Sr bioavailability in various soil-chemical condition on different tracks of fallout.

Radionuclides stocks in natural and man-caused objects on the Zone (territory of the Zone, pond-cooler, PRAWD, PTLRAW, Object "Chelter) has estimated.

Radionuclides fluxes inside of EZ and activity outflux out of EZ borders from natural objects as well as man-caused objects on the Zone territory are considered. Quantitative assessment of radionuclide fluxes on EZ territory as well as outside of the Zone borders with biological objects, due to man-caused fluxes, wind transfer and water outflux are discussed.

Depending on weather condition radionuclide water flux outside of EZ borders is predetermined maximal quota (84 – 96%) to annual total outflux. Radionuclide wind transfer is less significant, quota of this one to annual total outflux is varied from 3.5 to 14%, and up to 20% in case of forest fires. Quota of radionuclide biogenic transfer as well as man-caused migration is significantly less.

Role of autorehabilitation processes in formation of EZ radioecological characteristics at the late phase of the accident are considered.

**URANIUM (VI) SORPTION ONTO ROCK SAMPLES FROM AREAS
“KAMENNY” AND “ITATSKY” (NIZHNEKANSKY MASSIVE)**

**N.V. Kuzmenkova¹⁾, V.G. Petrov²⁾, I.E. Vlasova²⁾, V.A. Petrov³⁾,
V.V. Poluektov³⁾, S.N. Kalmykov²⁾**

¹⁾ - Vernadsky Institute of Geochemistry and Analytical Chemistry, Russian Academy of Science, Moscow, Russia

²⁾ - Lomonosov Moscow State University, Department of Chemistry, Moscow, Russia

³⁾ - Institute of Geology of Ore Deposits, Petrography, Mineralogy and Geochemistry, Russian Academy of Sciences (IGEM RAS), Moscow, Russia

The accepted in Russia concept for high level wastes (HLW) and spent nuclear fuel (SNF) disposal is based on their isolation into the deep underground crystalline rock formations. Three areas of the Nizhnekansky Granite Massive, namely “Kamenny”, “Itatsky” and “Eniseysky”, are supposed as the most perspective locations for the future HLW and SNF repository.

Core materials from two perspective areas (“Kamenny” – drilling depth down to 700 m; “Itatsky” – drilling depth down to 500 m) have been studied in terms of petrographic and mineralogical characterization; definition of filtration, elastic, petro-physical and strength properties; estimation of hydrothermal-metasomatic transformation of rocks.

Preliminary results show some equal uranium behavior and at the same time significant differences between used rock samples in sorption rate and pH-dependence. In the both areas maximum sorption (more than 90%) reach in 14-15 days. Equilibration time is five days and two weeks in the case of samples “Kamenny” and “Itatsky”. The pH-dependence of sorbed uranium fraction has typical hump-shape for samples “Kamenny” and “Itatsky”: increase of sorption percentage with increasing pH values to 6, plateau (90-98 % of uranium sorbed), decrease of sorption percentage with increasing pH values from 8 due to U(VI) hydrolysis. In contrast, the fraction of sorbed uranium (VI) was around 95-98 % in the pH range from 4 to 10 in the case of sample “Kamenny”.

Local distribution and preferential sorption of uranium (VI) onto different minerals within the sample was studied by radiography, SEM-EDX, SIMS, etc. These data accompanying with rock sample composition allow the development of quantitative model for U(VI) sorption onto investigated rocks.

This work was supported by the Ministry of Education and Science of Russian Federation (contract 14.U02.21.1527).

ANALYSIS OF THE RADIOACTIVE SAMPLES FROM RESERVOIR V-17 (OLD SWAMP)

**N.V. Kuzmenkova¹⁾, I.E.Vlasova²⁾, Yu.A. Sapozhnikov²⁾, E.A. Pryakhin³⁾,
W. de Paolo⁴⁾, I.A. Ivanov⁵⁾, S.N. Kalmykov²⁾**

¹⁾ – *Vernadsky Institute of Geochemistry and Analytical Chemistry RAS, Moscow, Russia; kuzmenkova213@gmail.com*

²⁾ – *Lomonosov MSU, Chemistry Dep., Leninskie Gory 1/3, Moscow, Russia*

³⁾ – *Urals Research Center for Radiation Medicine, Chelyabinsk, Russia*

⁴⁾ – *National Atomic Energy Commission, National Program for Radiactive Waste Management, Argentina*

⁵⁾ – *FSUE Mayak PA, Ozyorsk*

Russia Reservoir V-17 (Old Swamp) was formed as a result of the building dams in 1952 and 1954 (MAYAK Production Association), located in a natural depression relief. Here is intermediate level liquid radioactive wastes (ILLW) were discharged since 1949. The total activity of V-17 is more than 74 PBq whereas the reservoir sediments include the major portion of the activity (more 99%). Forthcoming stoppage of ILLW discharge and preparation for reservoir conservation require the special study of radionuclides migration behavior to be carried out. The water surface area of the lake is 0.13 km², and the volume is of 0.36 million m³. The maximum depth is 6.5 m with the average value 2.8 m.

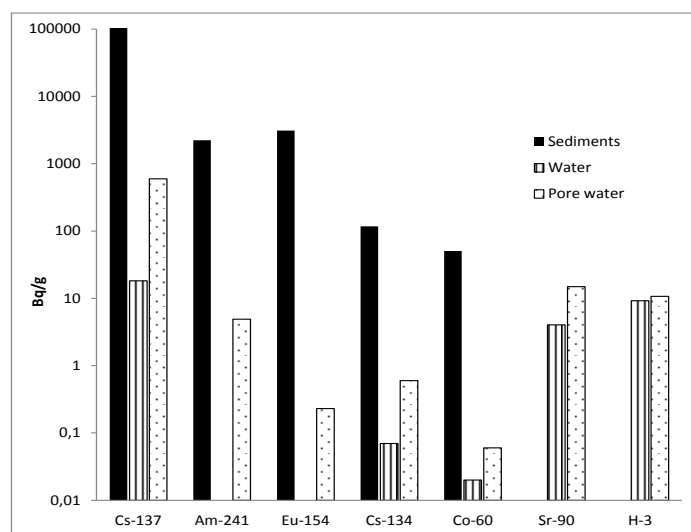

Fig. 1. Results of the investigations of radioactivity in V-17.

As a result of field research of the reservoir, 8 samples of bottom sediments and water were collected. Pore waters were separated from the wet sediments by centrifugation. All samples were analyzed by gamma spectrometry using HPGe detector Canberra GR 3818. The total amount of tritium in the pore and lake waters was determined by liquid-scintillation counting. The strontium was detected by Cherenkov counting daughter radionuclide ⁹⁰Y.

The first average results show maximum in sediments and minimum in water (Fig. 1). Availability of ¹³⁴Cs indicates the fresh radioactive wastes in reservoir.

This work was supported by the Ministry of Education and Science of Russian Federation (contract 14.U02.21.1527).

SPECIATION OF NEPTUNIUM IN SOILS AND ITS ACCUMULATION BY BIOTA

E.A. Lavrinovich, A.V. Abramova, A.P. Novikov

*Vernadsky Institute of Geochemistry and Analytical Chemistry, Russian
Academy of Sciences. Kosygin Str., 19, 119991 Moscow, Russia,
novikov@geokhi.ru*

It is known that many radionuclides can accumulate by biogeocenosis components and incorporate into food chains. However, only the behavior of gamma-emitting short-lived isotopes has been studied comprehensively at present. Bioaccumulation of alpha-emitting and the most toxic isotopes of actinide elements have been studied less due to methodological difficulties of radiochemical analysis. Laboratory researches show a high degree of actinide sorption, primarily of neptunium, by microorganisms and plants.

The main problem of determining the coefficients of actinide accumulation by biota is the impossibility of direct detection of their content and the significant influence of the organic substance on the yield of the analyte during alpha-spectrometric determination. A method for determining actinides according to the luminescence of crystallophosphors was developed and tested in the Institute of Geochemistry and Analytic Chemistry n.a. Vernadsky. A photometer and membrane modules for their concentration and speciation, were created. The method is particularly useful when analyzing natural objects, because it doesn't require prior separation of actinide elements, as well as cleaning the sample from alkali and alkaline-earth elements. The conducted researches have shown that the main natural elements capable of luminescence - Os, Re, Nb - do not affect the luminescence intensity of neptunium at a wavelength of 1713 nm. Actinide luminescence is induced by the ultraviolet radiation of the crystallophosphor located at room temperature. The construction and method of work on the unique installation were protected by patents of the Russian Federation in 2011.

The present research studies the processes of bioaccumulation and biotransformation (changing of speciation) of the most toxic, alpha-emitting actinides on real biological objects, selected in the areas of the East Ural Radioactive Trace (EURT), Krasnoyarsk Mining and Chemical Combine (KMCC), Kirovo-Chepetsk Chemical Combine (KChCC) and in the impact zone of the Kraton underground nuclear explosion.

It has been established that the relative content of water-soluble and exchange forms of neptunium is 5-10 times higher than the relevant values for plutonium and americium. Among long-lived radionuclides only ^{90}Sr has similar solubility.

In the EURT soils, neptunium accumulates mainly in the bedding and upper layer if it contains remainders of vegetation. In the sandy soils of KChCC, neptunium is found at a depth of 8 m. Also, in flooding soils and sediments of the Yenisei River (near KMCC) the content of ^{237}Np in the lower layers of the cores amounts to 1.1-4.5 Bq/kg, whereas in the top of the core, its concentration is below the detection limit of our definition method.

In the soil organic matter the main content of neptunium was found in the fulvic acids fraction and low molecular weight acids (below 43%), and moreover, up to 25% of neptunium is directly binded to the low molecular weight substances of non-specific nature. This, apparently, provides its high bioavailability.

Neptunium is found in the aquatic vegetation of the Yenisei River. The water plant *Fontinalis antipyretica* (water moss), in the dry biomass of which the maximum specific activity of neptunium amounts up to 10 Bq/kg, accumulates it most actively.

The content of neptunium in the vegetation in the impact zone of the Kraton underground nuclear explosion increases in the line: lingonberry (*Vaccinium vitis-idaea*) < mountain ash (*Sorbus aucuparia*) < sedge (*Carex riparia*) < lichen (*Hypogymnia physodes*) < larch needles (*Larix sibirica*) < moss (*Cladonia rangiferina*).

The bones of hares contain 10 times more neptunium than muscle tissue.

ISOTOPE EXCHANGE OF ^{45}Ca AND ^{14}C ON CALCITE

J. Lempinen, S. Kallio, M. Hakanen, J. Lehto

*Laboratory of Radiochemistry, Department of Chemistry, University of Helsinki, P.O. Box 55, 00014 University of Helsinki, Finland,
janne.lempinen@helsinki.fi*

Radiocarbon (^{14}C) is formed in nuclear fuel and surrounding metal materials by neutron activation reaction of stable nitrogen $^{14}\text{N}(\text{n},\gamma)^{14}\text{C}$. The speciation of radiocarbon in spent nuclear fuel is unknown, but it is assumed that radiocarbon will be in the form of elemental carbon and/or insoluble carbides. These forms of carbon may be oxidized to more soluble species such as carbonate due to the radiolysis of water caused by the radiation of the spent nuclear fuel. Because of the strongly reducing conditions in the deep bedrock it is possible that the soluble carbonates are reduced and methane is formed. The methane dissolved in groundwater is not retained by minerals and can thus passively migrate to the upper layers of the bedrock with the groundwater flow. Because of the higher redox potential or microbial activity of the upper bedrock the methane may be again oxidized to carbonate.

Radiocarbon in carbonate species can be retained by calcite mineral (CaCO_3) because of isotopic exchange. In equilibrium state calcite is dissolved and precipitated continuously. Thus radiocarbon in contact with calcite-bearing rock fractures can be incorporated into calcite by precipitation. Radiocarbon can thus form a solid solution with the calcite mineral in bedrock through isotopic exchange. In the present study the isotopic exchange in calcite was investigated using $^{45}\text{Ca}^{2+}$ and $^{14}\text{CO}_3^{2-}$ tracers.

Experiments were done in deionized distilled water, 0,1M NaCl solution and solutions of varying CaCl_2 and NaHCO_3 concentrations. 1.0 g samples of reagent-grade calcite (CaCO_3) were placed in centrifuge tubes and 30 mL of the desired solution was added. The samples were left to stand until solubility equilibrium between solution and solid CaCO_3 was attained. The solutions were then spiked with ^{45}Ca and $^{14}\text{CO}_3^{2-}$ tracers. Subsamples were taken at time intervals reaching from one day to several weeks. Subsampling was done by centrifugation of the tubes and pipetting 300 μL of the solution into an LSC vial. The subsamples were mixed with Opti-Fluor LSC cocktail. The ^{14}C subsamples were mixed with 0,1M NaOH before adding the LSC cocktail to prevent radiocarbon gassing out as carbon dioxide. The activities of the solutions were then measured by liquid scintillation spectrometry. These experiments will be continued until the isotope exchange reaches equilibrium state where the activity concentrations remain constant.

A decrease in the activity concentration as a function of time was observed for both radionuclides in all the solutions. This decrease is a consequence of the radionuclides precipitating in the calcite phase thereby increasing the activity in the calcite phase. This can be considered evidence of the isotope exchange process taking place. New experiments with synthetic reference groundwaters that simulate the composition of the Olkiluoto final deposition site groundwaters are in progress. The aim of the present study is to quantitatively describe the rate and extent of the isotopic exchange of ^{14}C and ^{45}Ca on calcite.

SORPTION OF CESIUM ON PEAT

**M. Lusa¹⁾, S. Virtanen¹⁾, J. Lempinen¹⁾, A.T.K. Ikonen²⁾,
A.-M. Lahdenperä³⁾, J. Lehto¹⁾**

¹⁾ – *Laboratory of Radiochemistry, Department of Chemistry, University of Helsinki, P.O. Box 55, 00014 University of Helsinki, Finland*

²⁾ – *Posiva Oy, Olkiluoto, 27160 Eurajoki, Finland*

³⁾ – *Saanio & Riekkola Oy, Laulukuja 4, 00420 Helsinki, Finland*

In Finland spent nuclear fuel is planned to be disposed of in a deep bedrock repository. Among the most important radionuclides in the long-term safety assessments is ¹³⁵Cs. In this study the sorption of cesium on peat samples from the Lastensuo mire was examined using model laboratory experiments, in which distribution coefficients (K_d) of Cs were determined. Experiments were performed by stabilising 0.2 g of air-dried peat samples, 25 ml of bog water model solution and ¹³⁴Cs tracer for 1 to 84 days under constant stirring, which after the samples were centrifuged, filtered through a 0.2 µm syringe filter and the ¹³⁴Cs activity of the solution was determined. K_d values were calculated from the difference between the initial and final ¹³⁴Cs activity. 1 M CH₃COONH₄ extraction (pH 4.5) and ICP-MS were used to determine the cation exchange capacity (CEC) of the peat samples. CEC was calculated as a sum of the extracted Na, K, Ca, Mg, Fe and Al concentrations.

Figure 1 presents the distribution coefficients of cesium as a function of depth, CEC and pH. As seen in Figure 1A the distribution coefficients of cesium increase as a function of depth as well as a function of CEC (Fig. 1B) and pH (Fig. 1C). Also the CEC values increased as a function of depth from 11 meq/kgDW in the upper layer to the 34 meq/kgDW in the lowest peat layer. This is likely a consequence of the difference in the organic matter and mineral matter content of the different peat layers. In the lowest peat layer there is evidence of clay minerals, such as illite, in the XRD analyses of the samples. The clay minerals serve as more selective sorbents for cesium than organic matter. The difference in the mineral matter content and clay content between upper and lower layers presumably results in the difference between both the K_d values of cesium and the CEC values. The lower K_d values in the upper layers is presumably due to higher organic matter content resulting in lower pH due to organic acids from the degradation of the organic matter. As the organic matter content decreases in the lower layers the pH of the layer increases.

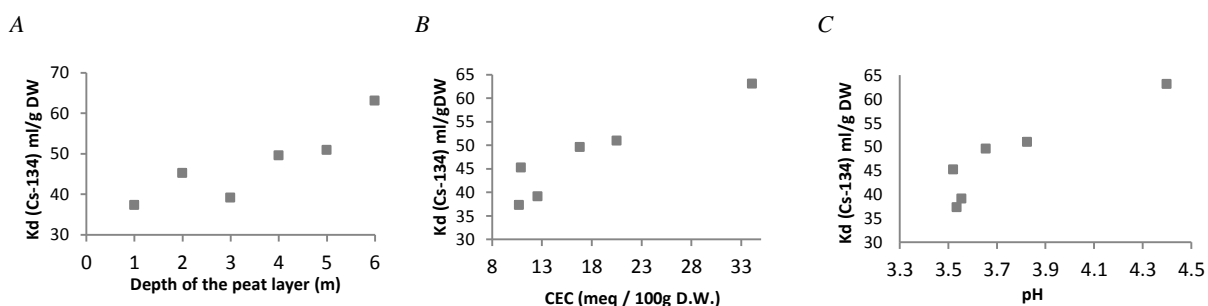

Fig. 1. The experimental K_d values for ¹³⁴Cs as a function of depth (A), CEC (B) and pH (C) for the 7 days equilibrium time.

COMPARISON OF SORPTION CHARACTERISTICS OF CRUSHED AND MONOLITHIC ROCKS

K.V. Martynov, L.I. Konstantinova, Yu.V. Konevnik, E.V. Zakharova

*A.N. Frumkin Institute of Physical Chemistry and Electrochemistry RAS,
Bld. 4, 31 Leninsky prosp., 119071 Moscow, Russia, mark0s@mail.ru*

Cs and Sr sorption from model ground water on samples of fine-grained leucocratic granite from the area of Beloyarsk nuclear power plant (B) were studied in a static mode under normal conditions. 10^{-5} - 10^{-6} Ci/l of ^{137}Cs and ^{90}Sr in the nitrates form were added to model ground water containing of CaCl_2 - 55.4, NaHCO_3 - 252, MgCl_2 - 47 and $\text{Sr}(\text{NO}_3)_2$ - 0.24 mg/l. The activities of radionuclides in solutions before and after 10 days of contact with the rock samples were determined by β - and γ -spectrometry. The monolithic disks cut from a drilling core and crushed sample of the rock (fraction less than 0.5 mm) were used. Geometrical surface area was considered for disks. The specific surface of crushed sample ($2180 \text{ cm}^2/\text{g}$) was determined by nitrogen adsorption using BET equation. The obtained experimental data were defined by Henry adsorption isotherm and surface distribution coefficients of cations were calculated: $K_d^{\text{Cs}}=6.52$ and 0.143 cm , $K_d^{\text{Sr}}=0.328$ and $1.54 \cdot 10^{-3} \text{ cm}$ for monolithic and crushed samples respectively.

Distinction of surface distribution coefficients of radionuclides for monolithic and crushed samples was earlier established at experimental studying of $^{241}\text{Am}(\text{III})$ and $^{238}\text{Pu}(\text{IV})$ sorption on Nizhnekanskiy granitoids (N) and andesite-basaltic metavolcanites from the PA Mayak area (M) [1]. There are at least two reasons for an explanation of this distinction. The first of them consists in addition of sorption on a surface with diffusion of components in pore (intergrain) space of monolithic samples. Using known unsteady-state diffusivity for similar

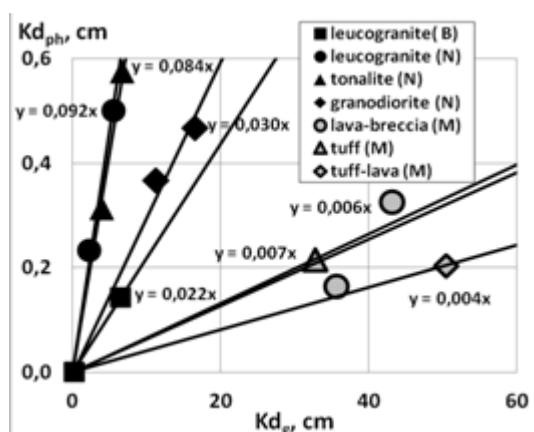

rocks we found that during experiments only for Sr diffusion contribution is significant (33% from quantity of the substance extracted from solution). The contribution of a diffusive component to results of experiments for other nuclides (Cs - 2%, Am - 0.003%, Pu - 0.06%) can be neglected. Taking into account correction on diffusion K_d^{Sr} is equal 0.22 cm for the monolithic sample.

The second and main reason consists in difference geometrical and real (physical) surfaces of monolithic samples connected with their roughness. The parameters of linear dependences shown on K_d_{ph} vs K_d_{g} plot represent values the return to roughness coefficients ($1/r=S_g/S_{\text{ph}}$). The studied rocks are divided into two groups: less rough granitoids ($r=10$ -45) and rougher metavolcanites ($r=140$ -250). The roughness can be measured in the independent way. To transfer experimental data on surface sorption obtained for crushed rocks (experimentally more convenient and correct technique) to monolithic rocks of a real massif corrective action on a roughness is obligatory.

[1] Anderson E.B. et al. *Radiochemistry*. 2007. Vol. 49. No 3. P. 305-318.

**EFFECT OF ORGANOMINERAL SORBENTS APPLICATION ON
BEHAVIOR OF ⁹⁰Sr IN SOIL – PLANT SYSTEM**

L.N. Maskalchuk, A.A. Baklay, T.G. Leontieva

*SSO «Joint Institute for Power and Nuclear Research - Sosny» National
Academy of Sciences of Belarus, 99, academician A.K. Krasin str.,
L.Maskalchuk@sosny.bas-net.by*

One of the main tasks in decommissioning of the consequences of radioactive contamination of environment which occur in the result of emergency emission and technogenic accidents at the enterprises of nuclear-energy complex is the rehabilitation of soils contaminated by radionuclides. This requires the knowledge of rules of radionuclides behavior in the soil and their migration in the soil – plant system.

Analysis of published data has shown that there is the inverse proportional dependence of ⁹⁰Sr accumulation by plants on the concentration of exchangeable calcium in the soil and directly proportional dependence on to the needs of the plants in this micronutrient. These dependencies are the general patterns of ⁹⁰Sr migration from soil to plant. On the basis of these data, and taking into account the assumption that ⁹⁰Sr in the soil solution is in a dynamic equilibrium with the two ion exchangers – the solid phase of soil and the root exchange complex – the mathematical model for ⁹⁰Sr migration from soil to plant was developed, and the analytical expression was received.

In frame of the mathematical model it has been shown that liming of acid soils to reduce the migration of ⁹⁰Sr from soil to plant has a limit determined by the cation exchange capacity (CEC) of the soil. As it is seen from this model, the further reducing of ⁹⁰Sr migration in plant on well limed soils is only possible by changing the sorption properties of soil, for example by insertion of sorbents for which sorption potential (SP) in relation to ⁹⁰Sr, defined from the expression $SP = K_c(Sr^{2+}/Ca^{2+}) \cdot CEC$, several tens of times higher than for the soil.

The effect of organomineral sorbents application on the behavior of ⁹⁰Sr in the system of well limed soddy-podzolic sandy soil – barley seedlings was studied. It was determined that in order to reduce the migration of ⁹⁰Sr from well limed soils into barley seedlings in 2 times under economically feasible application rate of sorbents (1–4 wt. %), it is necessary that the ratio of sorption capacities of the sorbent and the soil to be no less than 25 times, which is in a good agreement with the theoretical conclusions of the developed mathematical model. It is founded out that the effective sorbents for soils with SP level from 20 to 60 mmol/kg are black peat, organic sapropel and montmorillonite, for which the SP is 1000, respectively, 800 and 2500 mmol/kg for organic sapropel and montmorillonite.

The development of environmentally safety countermeasures for reducing of ⁹⁰Sr mobility in soils and protection of its migration into the food chain through the soil – plant system should provide the development and application of humic products with high sorption capacity based on peat and sapropels enriched by fine-grained clays which form stable organomineral complex capable of ⁹⁰Sr binding.

**RADIOECOLOGICAL CONDITION OF TAILINGS DAMS OF THE
MOUNTAIN PROCESSING ENTERPRISES OF APATITY-KIROVSKY
DISTRICT OF MURMANSK REGION**

N.A. Melnik

ICTREMRM KSC RAS, Apatity, Russia, e-mail: melnik@chemy.kolasc.net.ru

In 30 years of XX-eyelid in Xibiny a mining massif on Kola peninsula academician A.E.Fersman has discovered a high-grade deposit of an apatite. Since then on it is mountain - processing the factories of the Apatity-Kirov region of Murmansk range are mined and worked overtime apatite ore which are unique raw material for effecting phosphate fertilizers. The apatite-nefelin of ore in dependence on the content in ore basic породообразующих, the ore and акцессорных minerals is contained with natural radionuclides of a uranium-238 and thorium - 238 in quantity 0.0002-0.03 mas. %. At enrichment an apatite-nefelin of ores the part of radionuclides hits in the tailings guided to tailing dumps. For more than 80-years activity of the factories of a deposit of waste products of beneficiation have formed on lakeshore Imandra technogenic an apatite-nefelin a deposit (deposits 700 million t. waste products) which is not used yet. At the same time, tailing dumps of concentrating mills - a main polluter of an aerosphere, ponds and bedrocks toxic elements, including, natural radionuclides.

In this connection radioactively - hygienic properties of tailings of enrichment an apatite - nefelin of ores and a radioecological status of the uneven-age tailing dumps located in terrain of the Apatity-Kirov region were investigated: Kirov (plant ANOF-1 - in the term 1957-1962 yy.), Apatity (ANOF-2 - in 1963-1967 and being emergency at maintenance functions), Titan (ANOF-3 - since 1989 and on the present time). Idiosyncrasies of storages were determined by means of gamma-spectrometric and statistical analyses. The radiological examinations have shown, that contents of natural radionuclides in the investigated tailing dumps seasoned, behind exclusion of the content of radionuclides Ra-226 in Apatity and Titan storages.

Up the dip an efficient specific activity of assays (Bk/kg), select tailing dumps on a surface, place in the following sequence: Apatity (235) > Titan (270) > Kirov (285). For the Kirov storage typically tall content of radionuclide Th-232 reaching on the average 80-85 Bk/kg and a minimum percentage of radionuclides K-40, averaging 1360-1500 Bk/kg. It, apparently, is connected to the increased content initial dark-coloured minerals (and ore minerals) and a minimum percentage kalsilit in this technogenic education. Titan the tailing dump differs the tall content of radionuclides K-40 and Ra-226, 55-60 accordingly on the average 55-60 and 1580-1640 Bk/kg. It is possible to explain it according to increased the content kalsilit with which are enriched rischority and, probably, it is connected to the increased content in these mucks of micas. Minimum radioactivity is characteristic for Apatity tailing dumps in which waste products of enrichment differ a minimum percentage of natural radionuclides Th-232 and Ra-226. For the investigated installations maps - circuit designs of allocation of natural radionuclides which are recommended to use to ecologists of the factories composed. On the establishment of analysis of the received results the opportunity of reclamation of waste materials from tailing dumps in the capacity of technogenic raw material for secondary extraction of valuable ingredients is shown. For decrease of an anthropogenic load on investigated terrains recommendations for reclamation of waste materials in geotechnology, geocology and the project industry are developed.

**COMPARATIVE STUDY ^{137}Cs AND ^{90}Sr SORPTION BY REED PEAT
AT CHANGE OF WATER COMPOSITION**

T.B. Menshikh

«Mayak» PA, Ozyorsk, Lenina street, 29, secur.eco@mail.ru

The present study is concerning the absorbing properties of peat as one of the usual components of wetlands, which are used for cleaning of reservoirs from radionuclides. In the literature corresponding data on the characteristic of reed peat in waterlogged reservoirs has not met to us. At the same time, the influence of dead plant phytomass is resulted in increase of concentration of hydrogen ions (pH), nitrates and iron in stagnant wetland water. Our aim was to determine of the appropriate sorption parameters of reed wetland peat when the water composition was changed.

The given task was solved by modeling the influence of the additives of investigated chemical substances. According to it, in laboratory conditions the batch experiments were carried out to define the peat sorption parameters of radionuclides from water of an industrial reservoir V-3 of Techa Cascade of Reservoirs. The experiments included three variants and three replicates, in each of which in dried up, powdered samples of reed peat, according to the scheme of experience, water of the certain composition was added.

We studied the influence on sorption parameter of changed water composition by entering the additives as 0,1 M KOH and HNO₃ of solutions, saturated solution FeCl₃·6H₂O, and also KNO₃. In the first variant the experiments were carried out at pH from 2 up to 10. In the second and third variants – at the additives of nitrates from 0 up to 0,1 g/l on N and iron (3+) - from 0 up to 4,7 g/l, accordingly. Thus background parameters of water composition on the moment of research were follows: 9,1 (pH); 1,87 mg/l (nitrate nitrogen) and 0,1 mg/l (common) iron (3+)- considerably varied.

It was established, that the S value (%) of ^{137}Cs is mainly higher that of ^{90}Sr , remaining practically constant on all range of the investigated additives, on the data for 100 samples. At the same time for S value of ^{90}Sr the relation with iron (3+) concentration and pH was established. As for nitrates - it was not possible to reveal their influences on S value of both radionuclides. Thus, the radionuclide ^{90}Sr and ^{137}Cs behaviour in water of an industrial reservoir essentially varies and is determined by pH and nitrates and iron (3+) concentration.

SIZE DISTRIBUTION AND CONCENTRATIONS OF RADIOACTIVE AEROSOLS NEAR THE CHERNOBYL NPP: 1986-2013

B.I. Ogorodnikov, A.K. Budyka

Karpov Institute of Physical Chemistry, ul. Vorontzovo pole, 10, Moscow, 105064, Russia, e-mail: ogorod4@rambler.ru

On the night of 26 April, 1986, the greatest accident in nuclear-power engineering took place at fourth power-generating Unit of the Chernobyl Nuclear Power Plant (ChNPP). The active core and the upper part of the reactor building were completely destroyed as a result of the explosion. Radioactive contamination of territories near the ChNPP and in many European country occurred due to atmospheric transfer and fallout of radioactive aerosol particles on the earth's surface.

After the accident the measurements of aerosol characteristics near the ChNPP at different sampling points were provided. Usually filter materials FP (Petryanov's filter) were used. Three-layer packages consisting of filter materials FPA-70-0.1, FPA-70-0.2 and FPP-15-1.5 were used for the simultaneous determination of the concentration and disperse composition of radioactive aerosols. All materials were developed and produced by Karpov Institute of Physical Chemistry. After the sampling all filters were measured by means of standard methods of radiometry and spectrometry of ionizing radiation. In some cases, radiochemical methods were used.

In the first period after the accident ^{95}Zr , ^{95}Nb , ^{103}Ru , ^{106}Ru , ^{131}I , ^{134}Cs , ^{137}Cs , ^{140}La , ^{140}Ba , ^{141}Ce , ^{144}Ce and others radionuclides were detected. From June 11 to July 11, 1986 the volume activity of sum of these radionuclides were within the range of 10-10000 Bq/m³ at the distance of 0.5-1 km from destroyed reactor. The measurements provided in July-September, 1986, demonstrated that, practically, all radionuclides were deposited on the same particle carriers. Activity median aerodynamic diameter (AMAD) of aerosols equals about 3 μm for ^{95}Zr , ^{95}Nb , ^{134}Cs , ^{137}Cs , ^{144}Ce and isotopes of Pu. At the same time, isotopes of ^{103}Ru and ^{106}Ru were identified on the smaller particle carriers with AMAD = 2.57 \pm 1.01 μm . In October and November 1986, when the areas near ChNPP were partially decontaminated and covered with gravel, sand and concrete, volume activity decreased by an order of magnitude as compared to levels observed in July-September.

Five years after the accident, when radioactive products with half-lives with less than 150 days had practically disappeared, our attention was, mainly, focused at the content of alpha-emitting aerosols, as they began to determine the dose due to ingress of substances by inhalation, and ^{137}Cs , which made a major contribution to external irradiation.

For the sampling of aerosols, several installations were constructed at distance 0.4-0.6 km from destroyed reactor. Practically, all the samples were obtained at 15-day exposure of FPP-15-1.5 filters. Aerosols of ^{134}Cs , ^{137}Cs , ^{144}Ce , ^{154}Eu , ^{155}Eu , ^{241}Am and others radionuclides were measured by gamma-spectrometry. Considerable (up to three orders of magnitude) differences in minimal and maximal values of both ^{137}Cs and ^{241}Am during comparatively short time period are observed, which was a consequence of antropogenic activity inside and outside of the "Shelter" object. From year to year the volume activities of radioactive aerosols are decreased. For example, since December 1992, the volume activity of ^{137}Cs aerosols decreased within seven years by approximately five times. This value is much more than that achieved due to radioactive decay (the half-life of ^{137}Cs is $T_{1/2} = 30.2$ years). The decreasing of volume activity of ^{137}Cs and other radionuclides in the air was associated with natural and man-made factors: embedding of accident products in the soil, decontamination of the region near the "Shelter" and planting of greenery on it, dust control at construction and erection works, etc.

More than 20 years the sizes of the carriers of radioactive products of the accident are remained stable: their AMAD was within the range of 3-8 μm . No separation of radionuclides (^{134}Cs , ^{137}Cs , ^{144}Ce , ^{241}Am , and $^{239, 240}\text{Pu}$) on particle size was observed. At the same time, ^7Be and ^{212}Pb (natural radionuclides) were detected on considerably smaller particles with AMAD 0.1-0.4 μm .

URANIUM RECOVERY FROM NATURAL WATER BODIES

Yu.V. Ostrovsky¹⁾, G.M. Zabortsev¹⁾, D.Yu. Ostrovsky¹⁾, V.P. Isupov²⁾

¹⁾ - ND PC «GSPI»-«Novosibirskiy «VNIPIET», B. Khmel'nitsky str., 2, Novosibirsk, 630075 (Russia) E-mail: ostrovsky@sibmail.ru

²⁾ - ISSCM SB RAS, Kutateladze str., 18, Novosibirsk 630128 (Russia) E-mail: isupov@solid.nsc.ru

Mineralized lakes in West Mongolia and Transbaikalia contain increased (up to 3 mg/l) concentrations of uranium and some other valuable components (Li, Br, B) and can be considered as a non-conventional source of hydromineral raw material [1]. Water processing is connected with the necessity of preliminary recovery of uranium from lake water. Precipitation and extraction methods are inefficient for the recovery of uranium from lake water because of the low uranium concentrations and high salt background (20-30 g/l).

Within the development of integrated processing technology for hydromineral raw material, it is proposed to extract uranium preliminarily using the sorption method.

In the course of investigation, we studied uranium sorption from lake water on synthetic anionites AM-P, Purolite A-400, Purolite A-560 at pH>7 [2] and from uranium-containing waste water on inorganic cationites T-3A, T-5 and T-52 based on titanium hydroxides and zirconium phosphates [3] at pH <7.

We determined the capacities of ionites in the static and dynamic modes, calculated the constants of the isotherms of Freundlich's equations, chose desorption conditions. Uranium concentration during desorption from the sorbents under test reaches 60 mg/l, which is comparable with uranium content in the product solutions during underground leaching.

Uranium-collecting agents can be hydroxyl compounds of iron obtained using the galvanochemical method [4]. The iron – coke system was studied as a galvanic couple. Iron gets polarized in the conducting solution and passes into the solution on the anode without applying any voltage from an external power supply.

Hydrated oxides and hydroxides of iron that are formed as a result of the electrochemical process sorb uranium from solution almost completely at $t = 20\text{ }^{\circ}\text{C}$ and $\text{pH}_{\text{init}} = 3,0 - 3,3$. Uranium recovery from compounds of iron can be carried out using the solution of ammonium carbonate.

Thus, the results provide evidence of the possibility to recover uranium from natural water bodies efficiently obtaining a commercial product, which makes subsequent recovery and processing of valuable components from mineralized lake water possible.

The work was supported by the Integration Projects of SB RAS No. 45 and No. 110.

References

- [1] Isupov, V. P.; Vladimirov, A. G.; Lyakhov, N. Z. et al. Uranium in saline lakes of Northwestern Mongolia // Doklady Earth Sciences. V. 437. Issue 1, P.352-356.
- [2] Ostrovsky Y.V., Zabortsev G.M., Lyakhov N.Z., Isupov V.P. Uranium recovery from mineralized water of the Shaazgay nuur lake (Mongolia) // Chemistry for Sustainable Development. 2012. V. 20. No. 6. P. 707-712.
- [3] Ostrovsky Y.V., Zabortsev G.M., Yakobchuk S.P., Aleksandrov A.B., Khlytin A.L. Selective recovery of uranium from complicated salt systems on inorganic sorbents // Radiochemistry. 2010. V. 5. No. 1. P. 60-62.
- [4] Ostrovsky Y.V., Zabortsev G.M., Aleksandrov A.B., Babushkin A.V., Khlytin A.L., Egorov N.B. Rehabilitation of technogenic water reservoirs of uranium production // Radiochemistry. 2010. V. 52. No. 3. P. 260-263.

**Cs-137 IN SEDIMENTS AND BENTHIC FAUNA IN THE EASTERN
PART OF GULF OF FINLAND**

I. Outola¹⁾, K. Vaaramaa¹⁾, H. Kankaanpää²⁾

¹⁾ - STUK- Radiation and Nuclear Safety Authority, Environmental Radiation Surveillance, Laippatie 4, P.O.Box 14, FI-00881 Helsinki, Finland

²⁾ - SYKE- Finnish Environment Institute, Marine Centre, Hakuninmaantie 6, P.O.Box 140, FI-00251 Helsinki, Finland

The Baltic Sea is the most contaminated sea in the world with respect of ¹³⁷Cs that originates from Chernobyl accident in 1986 and from atmospheric nuclear weapon tests in 1950's and 60's. ¹³⁷Cs remains long in environment due to its long physical half-life (30 year). Most of ¹³⁷Cs in the Baltic Sea is accumulated into the bottom sediments. Therefore, it is important to understand the behaviour of ¹³⁷Cs in sea bottom: distribution in sediments, possible redissolution from sediments into water and uptake of ¹³⁷Cs by biota living close to the sea bottom.

Joint Finnish- Russian Expedition was carried out 2-9.8.2011 in the eastern part of the Gulf of Finland. One of the goals of this expedition was to explore the radioactive levels in sediment, water and biota in the eastern part of Gulf of Finland. Radioactivity studies by STUK on the benthic fauna have previously been limited mainly to the surroundings of the nuclear power plants. Sediment samples were collected both from soft and hard bottoms (10 sites together). Results indicated that the soft bottom sediments contained 8 times more ¹³⁷Cs than hard bottom sediments. ¹³⁷Cs content in bottom sediments varied from 1.5 kBq/m² to 31 kBq/m². ¹³⁷Cs concentration in the benthic animals varied from 1-13 Bq/kg d.w. Erica tool was used to assess the dose from ¹³⁷Cs to the benthic animals.

Another goal of the expedition was to carry out radioactivity measurements on the research vessel itself using Russian manufactured NaI detector on board and then later to compare the results against measurements carried out in laboratory with HPGe detector. ¹³⁷Cs measurements from the soft bottom sediments carried out on research vessel were consistent with those carried out in the laboratory, but systematically higher (approximately 80%). However, Cs measurements carried in field from the hard bottom sediments appeared to be more problematic.

DISTRIBUTION OF RADON GROUND FLUX IN MOSCOW

T.B. Petrova¹⁾, P.S. Miklyaev²⁾

¹⁾ - Moscow State University

²⁾ - Sergeev Institute of Environmental Geoscience RAS

Important environmental problem that occurs in the development of modern cities is the assessment of the radon hazard. In this report, we want to share the experience of mapping of radon hazard.

To create Map of radon hazard of Moscow were used the results of engineering geological and environmental surveys for construction from 1998 to 2011. During the period were investigated more than 1500 construction sites. At each construction site were measured flux density of radon, gamma radiation dose rate at a height of 0,1 m and specific activity of radionuclides in the soil. Series of maps (Radon ground flux density, Radiation dose rate, Specific activity of soils) was created by interpolation using the software “MapInfo Professional”.

Analysis of the maps shows, that spatial distribution of the flux density of radon determined by the content (specific activity) of radium-226 in soil. And the content of radium-226 in soil determined by the lithological composition of soil. Our investigations proved that the regional background of radon flux density varies within 10 – 400 mBq/m²s in Moscow. The maximum flux density of radon is typical for clay soils with a concentration of radium 25 Bq/kg and more. Sandy soils with concentrations of radium less than 10 Bq/kg are characterized by low values of flux density of radon.

At some construction sites discovered anomalously high values of flux density of radon. These abnormal sites, distributed on the territory of the city are not evenly, but form distinct isometric and elongated areas clusters. Our investigations proved that areas clusters of abnormal flux density of radon are associated with decompression the upper crust in the zones of modern geodynamic activity. Based on the synthesis of radon flux density map, map of radium content in soil, lithological map and geodynamics map of the city, was established Map of radon hazard of Moscow. The reported study was partially supported by RFBR, research projects No. 13-05-00975a and No. 13-05-01112a.

DISTRIBUTION OF RADIONUCLIDES IN THE ABIOTIC AND BIOTIC COMPONENTS OF THE ECOSYSTEM OF RESERVOIR R-17 "MAYAK"

**E.A. Pryakhin¹⁾, G.A. Tryapitsyna¹⁾, S.S. Andreev¹⁾, D.I. Osipov¹⁾,
N.I. Atamanyuk¹⁾, A.V. Konovalov²⁾, I.A. Ivanov²⁾**

¹⁾ – *Urals Research Center for Radiation Medicine*

²⁾ – *Central Plant Laboratory, PA «Mayak»*

In 2009 a comprehensive investigation of the ecological system of the reservoir R-17 "The Old swamp" - intermediate-level radioactive waste storage facility "Mayak" (Chelyabinsk region, Russia) was performed. The averages over the water area contents of radionuclides in water reservoir R-17 was as follows: ⁹⁰Sr - 1,4×10⁵, ¹³⁷Cs - 3,7×10⁴, ³H - 1,6×10⁶, ²⁴¹Am - 5,0×10¹, ²³⁸Pu - 1,7×10¹, ^{239,240}Pu - 1,7×10¹, ²³⁴U - 1,9×10¹, ²³⁸U - 1,1×10¹ Bq/l. The averages over the water area contents of radionuclides in bottom sediments were: ⁹⁰Sr - 2,0×10⁷, ¹³⁷Cs - 5,6×10⁷, ²⁴¹Am - 5,8×10⁶, ⁶⁰Co - 4,7×10⁴, ²³⁸Pu - 5,1×10⁵, ^{239,240}Pu - 3,4×10⁶ Bq/kg of dry weight. Moreover, industrial pollution of water reservoir R-17 is characterized by a high mineralization of water, preferably due to the high concentration of nitrates in it - 2.5 g/l.

The following table shows the content and concentration factors in hydrobionts of main dose-forming radionuclides - ¹³⁷Cs and ⁹⁰Sr.

Table. The content and concentration factors of ⁹⁰Sr and ¹³⁷Cs in hydrobionts in reservoir R-17

Environmental groups of hydrobionts	Radionuclides content, Bq/kg fresh weight		Concentration factors	
	¹³⁷ Cs	⁹⁰ Sr	CF _{137Cs}	CF _{90Sr}
Phytoplankton	1,3×10 ⁵	4,2×10 ⁵	3,5	3,0
Zooplankton	2,0×10 ⁵	3,7×10 ⁵	5,6	2,7
Zoobenthos	3,2×10 ⁵	4,5×10 ⁵	8,7	3,3

Note: CF – Concentration factor

Evaluation of the biota in reservoir R-17 allows us to conclude that in the reservoir under the condition of high content of radionuclides and nitrate ions formed biocenosis, which includes major environmental groups - bacterioplankton, phytoplankton, zooplankton and zoobenthos - and has expressed signs of ecological regression. For the plankton community is characterized by a relatively high diversity of the sudden dominance of single species, benthic community is extremely chironomids.

POLONIUM-210 IN MEDICINAL PLANTS

E.V. Puchkova, O.G. Bogdanova, A.M. Zarubo

*Saint-Petersburg State University, 199034, Russia, SPb, University emb., 7/9
evpuchkova@yandex.ru*

As it follows from the World Health Organization's data, in the last decades there has been a growing popularity of medicines derived from plant raw materials [1]. In plants, including the medicinal ones, specific radioactivity of ^{210}Po can reach several tens of Bk/kg [2, 3]. The aim of this work is to estimate the effective annual radiation dose due to Polonium-210 in humans who have undergone a course treatment with medicinal plants purchased via the network of pharmacies. In the work, the medicinal plants were studied that had passed the state radiation control. The content of ^{210}Po in plant samples and water extracts therefrom was determined by alpha-spectrometry, that of ^{137}Cs , by gamma-spectrometry. The annual radiation dose in humans due to Polonium-210 when consuming herbal teas/phyto-teas was calculated based on an average 30-day course treatment. The experimental data are given in the Table.

№	Sample	Activity concentrations, Bk/kg		^{210}Po extraction in infusion, %	Annual effective dose (E), $\mu\text{Sv/a}$
		^{210}Po	^{137}Cs		
1.	<i>Rhamnus frangula L.</i>	58,6 ± 5,6	20,9 ± 3,7	2	0,22 ± 0,02
2.	<i>Quercus dalechampii Ten.</i>	31,3 ± 5,3	< 2,0	3	0,31 ± 0,04
3.	<i>Alpinia officinalis L.</i>	18,9 ± 4,1	-	4	0,13 ± 0,02
4.	<i>Ledum palustre L.</i>	52,5 ± 3,5	424 ± 40	2	0,56 ± 0,04
5.	<i>Betula pendula Roth</i>	29,5 ± 1,9	< 5,0	6	0,60 ± 0,04
6.	<i>Plantago major L.</i>	44,6 ± 6,8	< 3,0	6	0,47 ± 0,05
7.	<i>Artemisia absinthium L.</i>	14,8 ± 1,3	< 2,0	63	2,51 ± 0,05

For all samples, with the exception of № 4, which was taken in Belarus, specific radioactivity of ^{137}Cs is lower than that of ^{210}Po . Usually, it is from 2% to 6% of the total amount of Polonium in the original sample that goes into phyto-teas. The calculated E values are comparable to radiation doses obtained when consuming an annual amount of some staple foodstuffs (e.g., milk and vegetables). A conclusion is drawn on that the relative contribution of phyto-teas into the effective annual radiation dose due to Polonium-210 in humans is substantial and should be taken into account.

[1] Chan K. Some aspects of toxic contaminants in herbal medicines. *Chemosphere*, v. 52, 2003, p. 1361 – 1371.

[2] Narayana Y., Prakash V. Radioactivity in ayurvedic medicinal plants. *International Journal of Low Radiation*, v. 4 (3), 2007, p. 184 - 188.

[3] Desideri D., Meli M. A., Roselli C. Natural and artificial radioactivity of some medicinal plants. *J. Environ. Radioact.*, v. 101, 2010, p. 751 – 756.

DISTRIBUTION OF ^{137}Cs IN REINDEER MEAT: COMPARISON OF SITUATIONS WITH HIGH AND LOW ACTIVITY CONCENTRATIONS

T.M. Rasilainen, K. Rissanen

***Radiation and Nuclear Safety Authority/Regional Laboratory Northern Finland, Lähteentie 2, FI-96400 Rovaniemi, FINLAND,
Tiina.Rasilainen@stuk.fi***

The food chain lichen-reindeer-human is one of the most important routes for human exposure to ^{137}Cs in northern Finland. The distribution of ^{137}Cs in reindeer meat was investigated in cases of high and low activity concentrations, in order to find out if the usually sampled neck part represents reliably the activity concentration of the carcass as a whole. In slaughtering period 1986/1987 twenty reindeer were fed with lichen with activity concentration of 6 – 8 kBq/kg ^{137}Cs dry weight. The reindeer were slaughtered in the beginning of 1987, muscle tissues cut into specified sections and other soft tissues, organs and bones separated. ^{137}Cs activity concentrations of each tissue were measured. The results are discussed and compared with activity concentrations in the muscle tissues of one adult reindeer and one calf, slaughtered in winter/spring 2011/2012. The adult reindeer was pastured in natural pasture and the calf was kept in a yard and fed with fodder. The food of both animals contained presumably only low levels of ^{137}Cs .

In 1986/1987, the activity concentration of ^{137}Cs in reindeer muscle tissues was high, in the adults the average was 6.8 ± 1.8 kBq/kg fresh weight (f.w.) and in the calves 6.1 ± 1.6 kBq/kg f.w. Differences between the average activity concentrations of individual animals were large, even 40 %. Differences between specified muscle tissue sections were not so clear but still detectable, around 10 %. The highest values in muscle tissues were found in tender loin, and lowest in side or in abdominal muscles. The activity concentrations in calves were somewhat lower than in adults, but the distribution between body sections was similar. Activity concentrations in other tissues were mostly similar or lower than in the muscles, but some internal organs like thymus and kidneys were showing remarkably higher activity concentrations, up to 12.7 kBq/kg f.w.

In 2011/2012, the activity concentrations of muscle tissues were low. In the adult reindeer, the activity concentrations of body sections were 0.07 – 0.26 kBq/kg f.w. and in the calf only 0.002 – 0.003 kBq/kg f.w. The relative differences between body sections were larger than in 1986/1987 reindeers, 70 % at the largest.

According to the results, the activity concentration in the neck part may be somewhat lower than the average activity or than the activity in the commercially more important sections like tender loin. Nevertheless, measuring the neck gives a reliable estimation of the activity concentration of the reindeer carcass, and it can be used as a reference for monitoring the radioactivity of reindeer meat.

Besides ^{137}Cs , also the activity concentrations of ^{134}Cs in 2011/2012 samples were measured. They were very low, 0.3 – 0.8 Bq/kg f.w., showing that the Fukushima accident did not endanger the radiation safety of Finnish reindeer meat.

**COLLIDERS AND THEIR POSSIBLE GEORADIOCHEMICAL
EFFECTS ON THE ENVIRONMENT**

G.B. Ryazantsev¹⁾, I.N. Beckman¹⁾, D.A. Minyaeva²⁾

¹⁾ – *Lomonosov Moscow State University, Leninskie Gory, 1 bld.10, Moscow
119991, Russia, anis-mgu@mail.ru*

²⁾ - *Mendeleyev University of Chemical Technology of Russia*

A dangerous factor is considered, which may precede the formation of black microholes, strangelets, magnetic monopoles and other objects in colliders, – the probability of turning the Earth into the "iron planet" or the flow of iron asteroids and meteorites. Proceeding only from real experimental evidence and theory-based provisions: 1) the quark-gluon plasma is already an experimental fact, 2) the dependence of the binding energy per nucleon from the number of nucleons in the nucleus is both experimentally and theoretically accurate, so we can assert that at the present moment the technical conditions for an uncontrolled conversion of all the chemical elements in the elements of Fe-Ni-Co group are already established, with the probability of catastrophic consequences for the Earth still extremely low, but 3) the possibilities of colliders are growing at a high speed and the dangerous threshold can be overcome in a very short time. A special group, established by CERN to evaluate the safety of experiments, presented a report which states that the Large Hadron Collider is not dangerous. The other dangerous process, which may occur from the uncontrolled formation of quark-gluon plasma of large volume and density in the conditions of the CERN experiment, is not considered at all. During this process, any substance turns into a cloud of elementary particles, which will condense in the process of cooling into the most energetically favorable state – the elements of the iron subgroup, which have the greatest values of the binding energy of the nucleons in the nucleus. The released energy will support this process till the complete conversion of all the chemical elements of the substance into the elements of the iron subgroup. It is believed that the first experimental results on the quark-gluon plasma were obtained in 1990 at CERN Super proton synchrotron (SPS) (the concept of a fireball has deeper historical roots [1] and appeared for the first time in the physics of cosmic rays). Then, in 2000, also at CERN, the discovery of this "new state" of matter was announced. In the colliders, the energy of particles and the density of their torrent are continuously increasing, which naturally leads to a more "hot" chromoplasma, and to the increase of its volume and density. According to the prevailing ideas of today, the unlimited expansion of the fireball is very unlikely, but there are other opinions. For example, Academician E. Feinberg believed that the lifetime of fireballs is greatly underestimated [1]; Heisenberg's calculations were already giving the abnormally high cross-section of their formation [2]; and Fermi has long ago presented the scheme which allows a fireball to expand unlimitedly in the flow of the accelerator [3]. The works of B.L. Ioffe were also published [4], which presented the abnormal parameters of the fireball, significantly different from L.D. Landau's calculations [4]. The probability of formation of an abnormally large fireball could be significant. The reaction of "ferruginization" may obtain a global or nearly global nature. The possible protective measures to prevent the probable future catastrophe are being considered, as well as the hazardous geotectonic conditions of the experiments at CERN.

[1] E.L. Feinberg, *Uspekhi fiz. nauk.*, V. 139,1, 1983, p.3-49 (in Russian);

[2] Heisenberg W. - *Zs. Phys.*, 1952, Bd. 133, S. 65;

[3] Fermi E.-*Phys. Rev.*, 1951, v. 81, p. 683;

[4] Ioffe B.L. – *Zh. Eksp. Teor. Phys.*, 1974, V.20, 6, p.360-362 (in Russian).

CHALLENGES ASSOCIATED WITH RADIOACTIVE PARTICLES IN THE ENVIRONMENT

B. Salbu, O.Ch. Lind

*Norwegian University of Life Sciences (UMB)/
CERAD Centre of Excellence for Environmental Radioactivity, Norway*

Following historical nuclear events (e.g., nuclear weapons tests, nuclear reactor accidents, conventional detonation of nuclear materials, discharge from nuclear installation, leakage associated with nuclear waste) radioactive particles have been released into the environment. These entities can carry substantial amounts of refractory fission products, activation products, and transuranics, depending on the source and release conditions. Radioactive particles are defined as localised aggregates of radioactive atoms that give rise to an inhomogeneous distribution of radionuclides significantly different from that of the matrix background. In water, particles are defined as entities having diameters larger than 0.45 μm , i.e. will settle due to gravity, while particles larger than 2 mm are referred to as fragments. In air, radioactive particles are classified according to aerodynamic diameters, where particles less than 10 μm are considered respiratory. The radionuclide composition of particles will depend on the releasing source, while particle characteristics such as particle size distribution, crystallographic structures and oxidation states will also depend on the release scenarios.

Being point sources, radioactive particles are heterogeneously distributed in the environment, and environmental samples collected may not be representative. In addition, particles can be difficult to fully dissolve, leading to analytical inconsistencies and irreproducible results. Thus, in particle contaminated areas, the estimated inventories can therefore be underestimated. As particle weathering and remobilization of associated radionuclides will occur over time, these entities represent diffuse sources for future ecosystem transfer. Thus, analytical techniques providing information on particle characteristics such as size distributions, crystallographic structures, oxidation states, being variables influencing weathering, mobility and biological uptake, is essential for impact and risk assessment.

The present paper summarizes state-of-the-art analytical techniques to characterize radioactive particles that should be utilized within radiochemistry and radioecology, when the radiological situation in particle contaminated areas is to be assessed.

**THE OB' RIVER BASIN AS A SOURCE OF GLOBAL FALLOUT ^{137}Cs
CONTAMINATION OF THE ARCTIC OCEAN**

I.N. Semenkov, A.Yu. Miroshnikov

*Institute of Geology of Ore Deposits, Petrography, Mineralogy, and
Geochemistry of Russian Academy of Sciences, 119017, Staromonetny 35,
Moscow, Russia, semenkov@igem.ru*

Nine great rivers discharge into the Arctic Ocean and transfer fallout cesium-137 from their watersheds. The highest concentration measured in the bottom sediments in the estuaries of the Yenisei and Ob Rivers. One of these anomaly zones formed in the Ob' estuary due to the geochemical river-sea boarder barrier. The main sources of ^{137}Cs in the Ob' River basin (180 – 190 kCi for 1945 – 2011) are runoff of global fallout and liquid radioactive wastes from plant association "Mayak" (0,3 – 3,2 kCi for 1958 – 2004).

The goal of our research is to calculate runoff of global fallout ^{137}Cs from the Ob' estuary macroarena. It includes the Ob' river basin (83% of macroarena total area) and smaller river basins flowing in the Ob' estuary.

Geographic information system (GIS) is made. The tenth-order river basins (n=154, Horton coding system) shape 20 groups due to topsoil properties controlling cesium mobility and slope type.

Six first order tributary river basins, characterized five groups of tenth order tributary river basins, were studied, and 600 bulk core soil samples were collected in 2011 and 2012.

The data obtained show that global fallout cesium-137 runoff from undisturbing humid first order tributary river basins (n=4) is less than $0.5 - 5.0 \text{ Ci} \times \text{km}^{-1}$. Runoff from arable semi-humid first order tributary river basins (n=2) varies from 14 to $15 \text{ Ci} \times \text{km}^{-1}$.

According to GIS, internal flow areas occur 23% of the macroarena total area and accumulate whole ^{137}Cs . Humid and semi-humid river basins cover 40% and 8% of study area respectively. We assume these basins yield the main contribution in cesium-137 runoff from the macroarena. Global fallout ^{137}Cs runoff summarized is 0.93 – 6.05 kCi (0.5 – 3.4 % of the total storage in the Ob' estuary macroarena) from humid and semi-humid river basins.

AEROSOL PARTICLES FROM CHERNOBYL LAVAS

A.A. Shiryaev¹⁾, I.E. Vlasova²⁾, B.I. Ogorodnikov³⁾, N.N. Dogadkin⁴⁾

¹⁾ - *Institute of physical chemistry and electrochemistry RAS, Leninsky pr. 31,
shiryaev@phycbe.ac.ru*

²⁾ - *Moscow State University, irinaeng@gmail.com*

³⁾ - *Karpov physico-chemical institute, ogorod4@rambler.ru*

⁴⁾ - *Vernadsky Institute of geochemistry and analytical chemistry RAS,
Kosygina str. 19*

During the catastrophic event at the Chernobyl NPP in 1986 flows of silicate-based highly radioactive lava-like material were formed inside the reactor building. According to some studies these Chernobyl lavas contain the major part (up to 150 tons) of irradiated fuel which was loaded into the reactor. At the time of their discovery (fall 1986) the lavas were mechanically very robust. However, field as well as laboratory studies performed since 1986 showed that the lavas deteriorate with time due to interaction with meteoric water and due to their metastable character. Several important studies of Chernobyl lavas were published between 1988 and 1996, but their present condition is less known. We report preliminary results of investigation of structure and composition of aerosol particles collected in the immediate vicinity of one the lava flow.

The aerosol particles were collected in 2012 in room 012/7 of the reactor building (ground level) using packs of Petryanov's filters allowing separation of the particles according to their aerodynamic radii. The filter holder was placed 15-20 cm away from the lava flow. Air pumping rate was ~100 l/min, duration of the pumping – 2 hours.

Earlier it was shown that in the room 012/7 the concentration of ⁹⁰Sr+⁹⁰Y and ¹³⁷Cs-bearing aerosols varied between 5 – 100 Bq/m³. Median aerodynamic radii of those particles was >1 μm, indicating dispergation mechanism of their formation. In the samples studied by us the first filter (the largest radii) contains the major fraction of radioactive particles. The activity is mostly due to ¹³⁷Cs with minor contribution of ²⁴¹Am. Autoradiography and α-track analyses show general spatial correlation between α-emitters and β- or γ- active grains. It is important to emphasise that radionuclide composition of the particles is identical to the composition of parent lava mass, clearly showing gradual lava destruction.

Morphology and composition of the particles separated from the filters by various means (dissolution, ultrasonication, etc.) were studied Scanning Electron Microscopy and Raman spectroscopy. The particles are generally less than 10 microns in size and are usually isometric with shapes corresponding to brittle cracking. The chemical composition of the particles is broadly similar to published lavas composition: silicate glass with minor amounts of Na and Al.

**RADIONUCLIDE AND METAL CONTAMINATION IN PIT LAKES
IN FORMER U SITES IN CENTRAL ASIA**

**L. Skipperud¹⁾, B.O. Rosseland¹⁾, P. Stegnar³⁾, M. Yunusov²⁾,
L.M. Burkitbaev⁴⁾, L.S. Heier¹⁾, B. Salbu¹⁾**

¹⁾ - *Norwegian University of Life Sciences, Isotope Laboratory, Department of Plant and Environmental Sciences, P.O Box 5003, NO-1432 Aas, Norway*

²⁾ - *Vostokredmet, Chkalovsk, Tajikistan*

³⁾ - *Josef Stefan Institute, Ljubljana, Slovenia*

⁴⁾ - *Al-Farabi Kazakh National University, Almaty, Kazakhstan*

The uranium mining industry in the USSR was established in the late 1940s - early 1950s in the former Soviet Republics of Kazakhstan, Kyrgyzstan, Tajikistan and Uzbekistan as part of the nuclear weapon program. In most countries, uranium mining is considered a hazardous step of nuclear materials production, both in terms of radiation doses and in the number of people affected. Key problems have been associated with the transport of uranium and its daughters in aquatic and terrestrial ecosystems, where radionuclides are transferred from air, water, and soils into plants, fish/animals and finally to man. In this paper, special attention is paid to the assessment of radionuclides and metals in Central Asian Pit Lakes.

Field works to Kurday, Kasakhstan, and Taboshar, Tajikistan, Pit Lakes have been performed. In addition to sampling of water, fish, sediments, and vegetation, in situ fractionation of water were achieved. The concentrations of U and associated trace metals were enriched in the Kurday Pit Lake and in the artesian water at the Kurday site (U exceeding the WHO guideline value for drinking water), and decreased downstream from the mining area. Uranium, As, Mo and Ni were predominantly present as mobile low molecular mass species in waters, while a significant proportion of Cr, Mn and Fe were associated with colloids and particles. Due to oxidation of divalent iron in the artesian ground water upon contact with air, Fe served as scavenger for other elements, and peak concentrations of U, Ra-isotopes, As and Mn were seen.

The U concentrations in water from Taboshar Pit Lake (2.0 mg U/L) were higher than waters collected in other areas in Tajikistan. The Pit Lake and the stream water from the tailing mountain were also characterized by elevated concentrations of As, Mo, Mn and Fe, exceeding the WHO recommended values for drinking water. Uranium, As, Mo and Ni were present as low molecular mass species in the waters, and are therefore considered mobile and potentially bioavailable.

Looking at fish, high BCF (L/kg) especially for ²¹⁰Po in bone, liver and muscle clearly demonstrates high accumulation of ²¹⁰Po in *C. auratus*, especially in the liver. A linear correlation between log ²¹⁰Po in liver and d15N could indicate biomagnification of ²¹⁰Po in liver of *C. auratus*.

These legacy sites, containing enhanced levels of natural radioactive material (TENORM) as well as heavy metals, may represent a hazard having a potential radiological and chemical impact on man and the environment, and measures should be taken to reduce the environmental risk to man and biota.

CEEPRA - COLLABORATION NETWORK ON EUROARCTIC ENVIRONMENTAL RADIATION PROTECTION AND RESEARCH

D. Solatie, A.-P. Leppänen

STUK- Radiation and Nuclear Safety Authority, Regional Laboratory in Northern Finland, Lähteentie 2, 96400 Rovaniemi, Finland, e-mail: dina.solatie@stuk.fi

CEEPRA (Collaboration Network on EuroArctic Environmental Radiation Protection and Research) is an EU-funded project acting under the Kolarctic ENPI CBC programme. The aim of the CEEPRA project is establishment of a cooperation network in the EuroArctic region, cross-border exchange of knowledge and skills, improvement of emergency preparedness capabilities and risk assessments in case of nuclear accidents. Additional aims are raising awareness and knowledge in the general public and stakeholders with respect to the nature, common challenges and associated risks in the area of nuclear safety, emergency preparedness and radioactivity in the environment.

The project is studying the current state of radioactive contamination in the terrestrial and marine ecosystems in the EuroArctic region by examining environmental samples collected from Lapland in Finland, Finnmark and Troms in Norway, the Kola Peninsula in Russia and in the Barents Sea. The results will provide updated information on the present levels, occurrence and the fate of radioactive substances in the Arctic environments and food chains. Special attention is given to collection and analyses of natural products widely used by general public in Finland, Russia and Norway, such as berries, mushrooms, fish and reindeer meat.

The region-specific risk assessments are carried out through modelling and studying of long-term effects of potential nuclear accidents in the EuroArctic region and possible impacts on the region's indigenous population, terrestrial and marine environments, reindeer husbandry, the natural product sector, tourism and industries.

Open seminars for general public and target groups have been arranged during the project implementation period to provide relevant information on radioactivity-related issues and the status in the region.

The project partners are Radiation and Nuclear Safety Authority (STUK) from Finland, the Murmansk Marine Biological Institute (MMBI) from Russia, the Norwegian Radiation Protection Authority (NRPA), Finnish Meteorological Institute and Pöyry Finland Oy. The Southern Scientific Centre of the Russian Academy of Sciences (SSC RAS) and Norwegian Meteorological Institute (NMI) are taking part in the project as well.

The preliminary results of the project are presented in a poster.

**CONTENTS RADIONUCLIDES IN WATER OF RIVER SYSTEM
TECHA-ISET-TOBOL-IRTYSH-OB**

**A.V. Trapeznikov¹⁾, V.N. Trapeznikova¹⁾, S.S. Andreev²⁾, A.V. Korzhavin¹⁾,
E.A. Pryakhin²⁾**

¹⁾ - Institute of Plant and Animal Ecology, Russian Academy of Sciences

²⁾ - Urals Research Center for Radiation Medicine

Radioactive contamination of the Ob-Irtysh river system is connected with a global pollution and man-made pollution associated with the activities of the nuclear complex of the USSR and the Russian Federation. The main source of pollution of the river system is the Production Association "Mayak" (Chelyabinsk region). As a result of activity of PA «Mayak» in last century Techa River (part of the Ob-Irtysh system) was contaminated.

To assess the contribution of the water of the Techa River in the radioactive contamination of the river system in 2009, it was determined the content of long-lived radionuclides ¹³⁷Cs and ⁹⁰Sr at a different distance from the formation of the modern source of the Techa River (below the dam P11 of PA "Mayak" Techa reservoirs). These studies are summarized in the table.

Table. Content of ¹³⁷Cs and ⁹⁰Sr in the water at a different distance from the source of the formation of the modern Techa River

Sampling locations	Distance from Dam D11, km	Specific activity, Bq/l	
		¹³⁷ Cs	⁹⁰ Sr
Techa R., "Assanov Bridge"	5	2.43 ± 0.24	12.2 ± 2.4
Techa R., "Nadyrov Bridge"	19	0.42 ± 0.08	10.5 ± 2.1
Techa R., s. Muslyumovo	44	0.37 ± 0.07	11,0 ± 2.2
Techa R., s. Brodokalmak	93	0.3 ± 0.06	11.8 ± 2.4
Techa R., s. Verhnaya Techa	126	0.17 ± 0.03	5.8 ± 1.2
Techa R., s. Nizhnepetrovskoe	136	0.14 ± 0.03	10.7 ± 2.1
Techa R., s. Lobanovo	151	0.14 ± 0.03	5.4 ± 1.1
Techa R., s. Bugaev	183	0.12 ± 0.02	4.8 ± 1.0
Techa R., s. Zatechenskoe	249	0.02 ± 0.004	6.3 ± 1.3
Iset R., below the confluence Techa R.	256	0.008 ± 0.0016	1.12 ± 0.2
Iset R., above the confluence Miass R.	398	0.006 ± 0.0012	1.04 ± 0.11
Iset R., above the confluence of the Tobol R.	608	0.009 ± 0.0018	0.42 ± 0.08
Tobol R., below the confluence of the Iset R.	622	0.003 ± 0.0005	0.240 ± 0.009
Irtysh R., s. Demyanskoye	1471	below the detection limit	0,0330±0,0004
Irtysh R. above the confluence to the Ob R.	1901	0,00073±0,0003	0,0249±0,0014
Ob R. above the confluence of the Irtysh R.	-	0,00036±0,00028	0,0152±0,0096
Ob R. below the confluence of the Irtysh R.	1952	0,0009±0,00028	0,0242±0,0008

As the table shows the distance from the main radioactive contamination, a regular decrease in the concentration of the studied radionuclides in water. The content of ¹³⁷Cs throughout the river system does not exceed the regulatory level according to the NRB 99/2009, and the content of ⁹⁰Sr content in the water of the Techa River in 2009 in its entirety was above the regulatory level, and after the confluence of the Iset River and below that is below the standard values.

**THE BEHAVIOR OF TECHNETIUM IN SEDIMENTS OF LAKES
DIFFERENT TYPES**

V. Tregubova, A. Safonov, K. German, V. Peretrukhin

*Frumkin Institute of Physical chemistry and Electrochemistry
Russian academy of sciences, 31, Leninsky prospect, Moscow, Russia
alexeysafonof@gmail.com*

The study of technetium accumulation by different microorganisms and their associations in bottom sediments is connected to man-caused environment contamination, and has two practical aspects: prediction of technetium ecological behavior in nature and places, adjoining to the long-term radioactive waste storages, and development of biological methods of low-active waste treatment.

The purpose of this work was studying of technetium behavior in biosystems, modeling bottom layers of fresh water lakes and Russia central regions' man-caused ponds, and possibility of technetium accumulation by microorganisms.

In this work Tc accumulation kinetics is studied in bottom sediments of eutrophic and dystrophic ponds, in static and dynamic conditions. Temperature, inorganic dirties (SO_4^{2-} , NO_3^- and sulfide ion) and microbiological composition of bottom layers fresh water ponds influence at Tc accumulation by bottom layers is studied.

Minimal rate of Tc transition into bottom layer is established for dystrophic lake. Tc accumulation rate increases with stirring in eutrophic lake case and decreases in dystrophic lake case, apparently because of active microbiota oppression.

Deceleration of Tc^{99} transfer to dystrophic lake sludge most likely explained by low lake stagnant microbiota stability for stirring and for even slight contact with air oxygen; wherein organic components of dystrophic lakes themselves (humic acids, peat) don't possess a technetium sorption ability.

The value of the mass in experimental samples determined gravimetrically of eutrophic and dystrophic lakes were 0,162 and 0,631 g respectively.

The value of the technetium absorption factor, calculated using this figures, for bottom layers were 9200 mg/g for eutrophic and 6.6 mg/g for dystrophic lake.

This work is supported by, RFBR project № 12-08-3127412, and federal program «Kadry» № 2012-1.2.1-12-000-2007-9066.

RE-DISTRIBUTION OF RADIONUCLIDES AND SECONDARY MINERAL FORMATION IN THE TALVIVAARA MINING PROCESS

**H. Tuovinen¹⁾, E. Pohjolainen²⁾, D. Vesterbacka¹⁾, C. Kirk³⁾, D. Read³⁾,
D. Solatie⁴⁾, J. Lehto¹⁾**

¹⁾ – *Laboratory of Radiochemistry, Department of Chemistry, University of Helsinki, P.O. Box 55, FI-00014 University of Helsinki, Finland*

²⁾ – *Geological Survey of Finland, Betonimiehenkuja 4, FI-02151 Espoo, Finland*

³⁾ – *Department of Chemistry, Loughborough University, Loughborough, Leicestershire, LE11 3TU, UK*

⁴⁾ – *Regional Laboratory of Northern Finland, Finnish Radiation and Nuclear Safety Authority, Lähteentie 2, FI-96400 Rovaniemi, Finland*

The Talvivaara deposits are located in the southern part of the Kainuu belt in Sotkamo, Eastern Finland. The deposits comprise one of the largest known nickel sulphide resources in Europe. Talvivaara is an operational, open cast mine where Talvivaara Mining Company uses bioheap leaching to extract the metals from the ore. In the bioheap leaching process uranium oxidizes from U(IV) to U(VI) and dissolves as uranyl ion (UO_2^{2+}) to the pregnant leach solution (PLS). As a consequence the radionuclides that belong to the uranium series dissolve too. The aim of this study is to generate new data leading to a better understanding of the behavior of ^{226}Ra , ^{210}Pb and ^{210}Pb , the radiotoxic daughters of uranium, in the Talvivaara mining process. In addition the formation of secondary minerals during the leaching process is poorly understood.

The samples were collected from the primary heaps, the secondary heaps, the PLS-ponds and gypsum pond on three occasions in 2011, 2012 and 2013. After pre-treatment, gamma spectrometry was used for direct determination of uranium and thorium progeny. Samples were then analysed by X-ray diffraction (XRD) to determine the main minerals present. The uranium-bearing minerals were determined with electron probe micro-analyser (EPMA). Uranium, thorium and heavy metals were determined by ICP-MS. For alpha spectrometry, uranium and thorium were separated using anion exchange chromatography, ^{210}Po with silver plate deposition and ^{210}Pb was precipitated from the remaining solution. Leaching experiments were performed in order to determine ^{226}Ra , ^{210}Pb and ^{210}Pb – bearing mineral phases.

The initial results do not only suggest the formation of secondary minerals but also the concentration of the initial ore minerals (Figure 1). According to preliminary studies, uranium is incorporated at least in goethite ($\text{FeO}(\text{OH})$) in the gypsum pond (Plate 1.). Radium is soluble and mobile in acidic conditions, but the high content of sulphates seems to restrict the solubility and ^{226}Ra is most likely bound to the crystal lattices of precipitated sulphate minerals. For lead, the formation of anglesite (PbSO_4) is probable and polonium is also most likely bound to secondary minerals in the heaps. The results will play an important role in estimating radiation doses and potential health implications to the local population resulting from past and anticipated disposal. A summary of the results gained to date is given in the presentation.

**STATISTICAL ANALYSIS METHODS APPLICATION
FOR THE DETERMINATION OF THE RADIONUCLIDE MIGRATION
IN THE NEAR-SURFACE STORAGE FACILITIES**

E. Veselova, A. Rybakov

***FSUI "RADON", 2/14, 7 th Rostovsky Per., 119121, Moscow, Russia,
Veselradon@gmail.com***

At the present moment the age of the most of near-surface waste storages is more than several decades and most of protective barriers have lost their original characteristics and are not able to provide necessary insulation. As a result, atmospheric precipitations penetrate into the storage and redistribution of radionuclides within the storage as well as their removal beyond the storage zone into the ground become possible. To evaluate the safety of the storage, first of all, it is necessary to determine the presence or absence of the storage tightness violation and, in case of need, try to evaluate its quantitatively and qualitatively. Examination of the storage facilities condition is effected by means of drilling of observation and research wells in the body of the storage and the ground of the nearby zone.

The results of the statistical evaluation of the geochemical studies of the geological objects has determined that as a rule the normal concentration distribution is typical for rock forming distributed elements and the concentration of rare chemical elements which quarks are less than 0.05% are distributed by lognormal. Also it was indentified that the nature of the statistical distributions of the components in the array is connected with the genesis of this geological formation. The same patterns are observed in the study of the technogenic pollution arising under the influence of industrial facilities for relatively small period of time.

For the near-surface RAW storage formation of a new geochemical solid field occurs under the conditions corresponding to the theoretical scheme of a lognormal distribution of radionuclides. It allows to conclude that there is connection between the intensity of migration and geochemical properties of the field, in particular, the statistical characteristics of the distribution of values of exposure rate. The closeness of the empirical distribution to the theoretical lognormal distribution the exposure dose rate (EDR) values indicates the degree of conversion of geochemical field of the RAW array and the development of radionuclide migration. With the development of migration the shape of the distribution is changing. That allows us to estimate the intensity and dynamics of migration. Correspondence of the empirical distribution to the theoretical one is determined by Pearson criterion (χ^2). This evaluation has been effected according to the results of several surveys of existing storage. First of all we should mention uneven distribution of the values of EDR and different nature of variability for different parts of the storage facilities. Clearly pronounced anisotropy of the geochemical fields of the RAW array points to the predominance of the horizontal migration of radionuclides. According to the results of the calculation of the coefficients of the correlation between neighbouring wells within the same section and on different sides of the walls, areas of probable destruction of the intersectional partitions inside the storage and availability of migration flows have been identified. The conformity of the statistical distribution of EDR for these sites (approximately at the depth of 2,0m) as well as the areas with a clear multimodal histogram which indicates the high heterogeneity of the studied complex has been determined. In these areas the RAW array has not been subject to the "smoothing" action of the migration and has kept the features of primary heterogeneity.

The proposed method array provide the unique possibility to obtain more complete data on the state of the array RAW and to evaluate the presence and intensity of migration processes in different parts of the storage that allows to examine the degree of preservation of the structural elements of the storage without additional production costs.

**MICRODISTRIBUTION OF ALPHA- AND BETA-EMITTING
NUCLIDES IN THE SEDIMENTS OF THE INDUSTRIAL RESERVOIR
V-17 (MAYAK PA) USING IMAGING PLATES**

**I.E. Vlasova¹⁾, N.V. Kuzmenkova²⁾, A.A. Shiryaev³⁾, E.A. Pryakhin⁴⁾,
S.N. Kalmykov¹⁾, I.A. Ivanov⁵⁾**

¹⁾ – *Lomonosov MSU, Chemistry Dep. Leninskie Gory 1, bld.3, Moscow, Russia, ivlas@radio.chem.msu.ru*

²⁾ – *Vernadsky Institute of Geochemistry and Analytical Chemistry RAS, Moscow, Russia*

³⁾ – *Frumkin Institute of Physical Chemistry and Electrochemistry RAS, Moscow, Russia*

⁴⁾ – *Urals Research Center for Radiation Medicine, Chelyabinsk, Russia*

⁵⁾ – *FSUE Mayak PA, Ozyorsk, Russia*

Industrial reservoir V-17 (MAYAK Production Association) has been accumulated intermediate-level liquid radioactive wastes (ILLW) since 1949. The total activity of V-17 exceeds 74 PBq whereas the reservoir sediments include the major portion of the activity (more than 99%). Forthcoming interruption of ILLW discharge and preparation for reservoir conservation require dedicated study of radionuclides migration behavior.

Computed radiography have been performed using Cyclone Plus Storage Phosphor System (PerkinElmer) in order to reveal microdistribution of different α - and β -emitting nuclides in sediments samples collected from the different parts of the reservoir V-17. The sediments samples along with the standards of ^{137}Cs , ^{90}Sr (^{90}Y) and ^{241}Am have been exposed for a short time (15 min) using a stack of 3 imaging plates (IPs). The rate of decrease of photostimulated luminescence (PSL) intensity from layer to layer of IPs depends on the type and energy of radiation. The comparison of PSL attenuation in the samples and standards allowed estimation of nuclide content of the individual microparticles.

We acknowledge the Ministry of Education and Science of Russian Federation (contract 14.UO2.21.1527).

THE APPROACHES TO REMEDIATION OF RADIOACTIVELY CONTAMINATED LANDS

A.V. Voronina, V.S. Semenishchev, M.O. Savchenko, T.V. Gorbunova

Ural Federal University, Russia, Ekaterinburg, a.v.voronina@mail.ru

The sorption method is the most prospective for remediation of radioactively contaminated lands where further habitation and agricultural activities are planned. Cheap and available sorption materials with good affinity to natural systems are needed for decontamination of large volumes of natural water (including drinking water), prevention of migration of radionuclides into ground and surface waters through the soil and returning contaminated soil to farming. Natural aluminosilicates satisfy these requirements; interest and their intensive study are determined by their ion exchange properties and also by availability of proven deposits in many countries. The efficiency of their using could be increased via chemical modification of the surface.

A comparative study of sorption properties with respect to caesium of various natural aluminosilicates (clinoptilolites from Shivyrtsoosky (Chita region, Russia) and Dzegvi (Georgia) deposits, quartz-glaucanite concentrate from Karinskoye deposit (Russia)) as well as surface-modified based on them is made in this work. The method of synthesis of surface modified ferrocyanide sorbents based on natural aluminosilicates is developed by Radiochemistry and Applied Ecology chair of UrFU. Changes of selectivity and chemical stability of glaucanites and clinoptilolites after chemical modification are analysed, the possibility of their use for rehabilitation of radioactively contaminated lands is studied.

Modification of the surface of glaucanite by nickel-potassium ferrocyanide allows to increase distribution coefficient of caesium up to $(4,5 \pm 0,5) \cdot 10^5$ mL g⁻¹ (while its value is $(2,9 \pm 0,8) \cdot 10^3$ mL g⁻¹ for natural glaucanite) as well as to make the sorbent selective to caesium in presence of another alkaline ions and also to provide the irreversibility of sorption. The chemical stability of the saturated samples was determined using the long-term leaching technique (National standart P 52126-2003) using tap, rain and mineral water as leachants, simulating all possible types of water with which the sorbent may contact. Total degree of caesium leaching from natural glaucanite after 35 days of leaching was: mineral water = 63.4%, tap water = 41.6% and rain water = 28.8%. For modified glaucanite the results in the same condition were: mineral water = 1.5%, tap water = 14.6% and rain water = 6.6%. It's obvious that high leaching rates and degrees are typical for natural glaucanite independently on type of leachant, therefore, it is expected that there will not be good retention of caesium in solid phase after addition of natural glaucanite to soil. In contrast to natural glaucanite, the modified glaucanite is a safe matrix for caesium immobilization, therefore, it could be used for remediation of lands contaminated by radiocaesium.

The ferrocyanide sorbents based on clinoptilolite are polyfunctional: mixed nickel-potassium ferrocyanide has three types of sorption sites and mixed iron-potassium ferrocyanide has two. Distribution coefficients of caesium are $(6,4 \pm 0,6) \cdot 10^3$ mL g⁻¹ for natural clinoptilolite, $(2,5 \pm 1,3) \cdot 10^7$ mL g⁻¹ for mixed nickel-potassium ferrocyanide (the best sorption site) and $(4,6 \pm 0,5) \cdot 10^4$ mL g⁻¹ for mixed iron-potassium ferrocyanide. The nickel-potassium ferrocyanide shows not only high specificity to caesium but also very high static exchange capacity: up to 500 mg g⁻¹. The selectivity of modified clinoptilolite samples depends of method of modification. Distribution coefficient of caesium from 2M NaCl solutions not less than 10^5 mL g⁻¹. Integral leaching rates of Cs from saturated sorbents by tap water are: $1,1 \cdot 10^{-9}$ g cm⁻² day⁻¹ for natural clinoptilolite, $3,3 \cdot 10^{-10}$ g cm⁻² day⁻¹ for mixed nickel-potassium ferrocyanide and $2,6 \cdot 10^{-10}$ g cm⁻² day⁻¹ for mixed iron-potassium ferrocyanide. Thus, the synthesis of ferrocyanide sorbents based on clinoptilolite allows to obtain prospective materials for remediation of natural water bodies and lands as well as for processing of large volumes of liquid radioactive wastes including high-salined solutions.

The study was supported by The Ministry of education and science of Russian Federation, project 14.A18.21.0313.

**DIFFUSION OF CESIUM IN GRIMSEL GRANODIORITE:
SIMULATIONS IN TIME DOMAIN WITH HETEROGENEOUS
SORPTION PROPERTIES**

M. Voutilainen¹⁾, P. Sardini²⁾, M. Siitari-Kauppi¹⁾, A. Martin³⁾, J. Timonen⁴⁾

¹⁾ - *University of Helsinki, Department of Chemistry, P. O. Box 55, 00014
University of Helsinki, Finland, ma.voutilainen@helsinki.fi*

²⁾ - *IC2MP, University of Poitiers, UMR 7285 CNRS, France,
paul.sardini@univ-poitiers.fr*

³⁾ - *Nagra, Hardstrasse 73, 5430 Wettingen, Switzerland,
andrew.martin@nagra.ch*

⁴⁾ - *University of Jyväskylä, Department of Physics, P. O. Box 35, 40014
University of Jyväskylä, Finland, jussi.t.timonen@jyu.fi*

In many countries crystalline rock has been chosen to be the host medium for the underground repositories of highly radioactive spent nuclear fuel. For the performance assessment and safety analysis of such repositories, it is vital to determine properties linked to the migration of radioactive elements in the surrounding bedrock. To this end, the underground rock laboratory at Grimsel test site in Switzerland provides the opportunity to develop and test equipment, methodology and models in in-situ conditions which are analogous to those at repository sites. Some parameters are difficult or impossible to determine in complicated in-situ conditions, and thus laboratory studies and numerical simulations are often needed when setting the parameters as well as when analyzing the results.

Mineral and structure heterogeneities have a considerable influence on the radioactive elements behavior in bedrock. The heterogeneities are present in multiple length scales in crystalline rock, but in this work we studied the effect of centimeter scale heterogeneity on diffusion and sorption properties of cesium using time domain diffusion (TDD) simulations.

In order to determine the heterogeneous structure of a Grimsel granodiorite sample, we applied X-ray computed microtomography, the ¹⁴C-labeled-polymethylmethacrylate (¹⁴C-PMMA) method and mineral identification. As a result we obtained a 3D mineral map of the sample showing distribution of main minerals. We determined unique values for porosity, distribution coefficient and apparent diffusion coefficient for each mineral, linked them to the 3D map and applied them in the simulations. The result of the simulation was compared to a one performed in homogeneous reference sample.

As a result we obtained apparent diffusion coefficients of 1.5×10^{-14} m²/s and 1.9×10^{-14} m²/s for the heterogeneous and homogeneous case, respectively. Consequently, heterogeneous sorption properties retard diffusive migration by 27 %, and make thus a relevant contribution to diffusion of cesium in Grimsel granodiorite. Result of simulation was also compared to those of in-situ diffusion experiments on cesium, and the results were found to be fair agreement. In these experiments cesium diffused into Grimsel granodiorite for 2.3 years in the in situ long term diffusion experiment (Grimsel Test Phase VI, LTD project).

**RADIOECOLOGICAL ASSESSMENT OF TOMSK-SEVERSK
NUCLEAR FACILITY TERRITORY ON THE BASED OF AEROSOLS
IN SNOW STUDY**

E.G. Yazikov, A.V. Talovskaya, E.A. Filimonenko

***Tomsk Polytechnic University, 634050, Tomsk, Lenin aven., 30, Russia
talovskaj@yandex.ru***

This study presents radio ecological assessment within Tomsk-Seversk industrial facility. Nuclear industry and fuel power supplying stations are located in Seversk city. Burning of fossil fuels and natural gas, industrial emissions from companies of construction, machine construction, mechanical engineering, food, pharmaceutical industries, match producing and petrochemical plant are the main atmospheric sources in Tomsk city.

Snow has been sampled in Tomsk-city and rural residential sites locating in the vicinity of the facility. The concentrations of U and Th were determined by neutron activation analysis for insoluble fraction of aerosols in snow. The f-radiography method was used to determine modes of fissionable radionuclides occurrence in the samples.

Results shows U concentration is in 10-15 times more than the background value, Th concentration – in 2 times more than the background value in the samples from Tomsk (Table). The most contrast part of U and Th concentration are situated on the territory of northeastern part of Tomsk where there are brick-making plant and local boiler plants as well as on territory of central part where there is fuel power supplying station. Insoluble fraction of aerosols in snow taken near the fuel power supplying station is enriched with U and rare-earth elements according to the data of several years' monitoring. The same elements are characteristic for the coals of Western Siberia (Arbuzov, 2007) that are used in Tomsk's boiler plants and fuel power supplying station. It was determined that U and Th are correlated with the ash yield that was emitted during burning of coal.

The concentration of radioactive elements decreases away from Tomsk-Seversk industrial facility area in the south-western direction. The north-east part from the facility was determined as the most polluted according to results of element concentration. The presence of uranium oxides was detecting by SEM in this samples. It was confirmed by the results of f-radiography method. The radioactive elements were detected in the dispersed modes distribution. The micro-inclusions concentrated modes of radioactive fissionable elements were revealed as well. The main source of these modes was found to be most likely emissions of nuclear-fuel enterprises of Seversk city.

Table. Concentration of radioactive elements in insoluble fraction of aerosols in snow and daily fallout of the elements within Tomsk-Seversk industrial facility

	average concentration, mg/kg		average daily fallout of the elements, mg/km ² per day	
	U	Th	U	Th
background area	0,2	2,9	1,4	20,3
Tomsk city	2,8±0,1	6,7±0,2	171±19,9	426±47,2
south-western area from facility	4,6±0,1	12±0,3	109±13,4	284±36,8
north-east area from facility	5,8±0,2	13,9±0,4	224±23,4	539±54,4

Thus, the main source of the radioactive elements was found to be most likely nuclear-fuel enterprises in addition to fuel and power supplying plants.

The research was partly funded by Grant of President of RF for young scientists (MK 951.20013.5).

**^{129}I RECORD IN THE TAAL LAKE SEDIMENT, PHILIPPINES:
IMPLICATION FOR GLOBAL FALLOUT OF ^{129}I IN LOW LATITUDE**

**L.Y. Zhang^{1,2)}, X.L. Hou^{1,2)}, W.J. Zhou²⁾, H.C. Li³⁾, N. Chen²⁾, Y.K. Fan²⁾,
Q. Liu²⁾, Y.C. Fu²⁾**

- ¹⁾ - *Center for Nuclear Technologies, Technical University of Denmark, Risø Campus, Roskilde 4000, Denmark*
²⁾ - *Xi'an AMS Center, SKLLQG, Institute of Earth Environment, China Academic of Sciences, Xi'an 710075, China*
³⁾ - *Department of Geosciences, National Taiwan University, Taipei, Taiwan*

^{129}I has been demonstrated to be a good environmental tracer¹. Despite a number of ^{129}I data has been published in the past years, less data is available in low latitude region. Aiming to provide significant information on the global distribution and temporal variation of ^{129}I in low latitude area, the sediment collected at the Taal Lake, with 120cm length covering 57 years, was analyzed to investigate ^{129}I deposition. Taal Lake, known as a volcanic lake, is located in central Philippines (14° 00.1'N, 120° 59.1'E), which is far away from nuclear facilities and weapon testing sites. Concentrations of ^{129}I in the core ranged from $(0.5\pm 0.07)\times 10^5$ atoms/g at 113.7 cm depth to $(215.92\pm 20.16)\times 10^5$ atoms/g at 7.1 cm. Compared to the other marine and terrestrial cores, levels of ^{129}I in the Taal Lake sediment were as similar as that from the Mississippi river, but 1-3 orders of magnitude lower than the European lakes and sea sediments. $^{129}\text{I}/^{127}\text{I}$ atomic ratios were found to be irrespective with sedimentary environment (marine and terrestrial systems), but reflected directly origin of ^{129}I . The source of ^{129}I in this sediment core and its comparison with other anthropogenic radionuclides are presented and discussed. The influence of volcanic activities, incursion of seawater and geothermal input on the distribution of ^{129}I in the sediment core are also discussed.

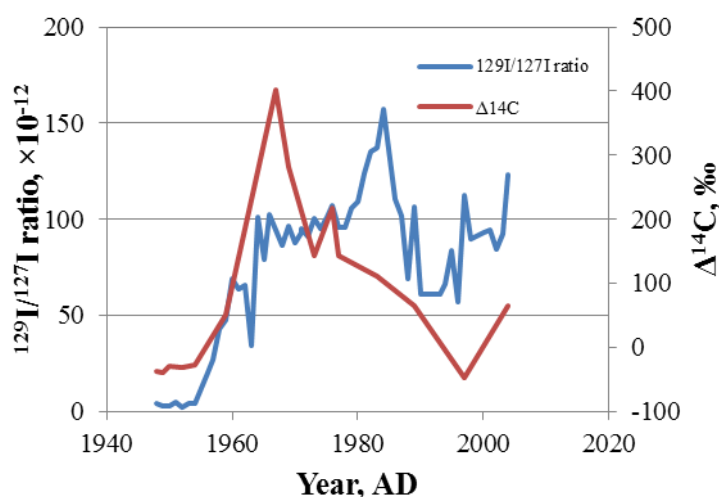

Fig. 1. Depth profile of $^{129}\text{I}/^{127}\text{I}$ ratio and $\Delta^{14}\text{C}$ in the Taal Lake sediment ($\Delta^{14}\text{C}$ from Reference 2).

[1] Hou, X.; Povinec, P.P.; Zhang, L.; Shi, K.; Biddulph, D.; Chang, C., et al. Iodine-129 in Seawater Offshore Fukushima: Distribution, Inorganic Speciation, Sources, and Budget. *Environ. Sci. Technol.* **2013**, *47*, 3091-3098.

[2] Li, H. and Xu, X. Dating Taal Lake sediment of Philippines by using the bomb radiocarbon curve. *American Geological Union* **2008**, #PP23A-1466.

5. Radioanalytical chemistry

**STUDIES OF URANIUM RED-OX STATES BY THE METHOD OF
CHEMICAL SHIFTS OF THE $L\alpha_1$ - $L\alpha_2$ EMISSION X-RAY LINES**

R.V. Bogdanov, A.G. Krivitsky, E.V. Puchkova

St. Petersburg State University, 199034, St. Petersburg, Russia
bogdanov@RB7584.spb.edu

For studies of chemical states of uranium in minerals, a methodology has been developed of a two-dimensional correlation diagram of chemical shifts for the $L\alpha_1$ - и $L\beta_1$ -emission X-ray lines [1]. This methodology enabled the content of U(IV), U(V) and U(VI) to be determined in naturally occurring oxides [2], as well as uranium chemical species to be identified in a series of oxygen-containing minerals [3], including the ones that are considered to be natural analogues of HAW matrices [4]. However, measurements made by using the $L\beta_1$ -line are laborious since these have to be conducted at low uranium concentrations (in the limit, on infinitely thin samples) because of the $L\beta_1$ -line being too near to the L_{III} -shell absorption edge of the uranium atom. Therefore, it was the $L\alpha_2$ -line (the $2p_{3/2}$ - $3d_{3/2}$ transition), which makes up a spin-doublet with the $L\alpha_1$ -line (the $2p_{3/2}$ - $3d_{5/2}$ transition), that was used as a complimentary line.

Chemical shifts (δ) were measured of the two lines for U_4O_9 , U_2O_5 , U_3O_8 and UO_3 reference oxides relative to the $UO_{2.008}$ oxide and a diagram was drawn in the $\delta L\alpha_1$ - $\delta L\alpha_2$ -plotting coordinates. The diagram is in the shape of a narrow segment that is formed by the two lines: a straight one that reflects chemical shifts in mechanical mixtures of UO_2 and UO_3 oxides, and a curve one that corresponds to chemical shifts in reference oxides of the UO_{2+X} composition. Since these dependencies are localized in a narrow area of the coordinate system, it presents difficulties when using the diagram for an analysis of redox states of uranium in its oxides. In consequence of this, in addition to oxides, there were chemical shifts measured for uranyl compounds: $UO_2(NO_3)_2 \cdot 6H_2O$, UO_2SO_4 , UO_2SeO_4 , as well as for U(IV) and U(III) chloro- and fluoro-compounds: UF_4 , $CaUF_6$, K_2UCl_6 , K_3UCl_6 .

Based on the measurements conducted, the following conclusions have been drawn:

1) within the area of positive chemical shifts of the $L\alpha_2$ -line there is a distinct differentiation observed between the positions of oxide- and uranyl species; 2) in the negative $\delta L\alpha_2$ area, a localization of tetravalent uranium species is observed; 3) chemical shifts of trivalent uranium are in the positive value area for both X-ray lines; 4) measurements made on sayrite mineral enabled the conclusion to be drawn on different positions of uranyl- and uranate compounds in the positive chemical shift area of the $L\alpha_2$ -line.

Thus, by using the $\delta L\alpha_1$ - $\delta L\alpha_2$ -correlation diagram, the possibilities can be broadened for studying chemical- and redox uranium states in both natural and synthetic compounds.

[1] R.V. Bogdanov, Yu.F. Batrakov, E.V. Puchkova, and A.S. Sergeev. Radiochemistry (English Translation of Radiokhimiya), 1999, Vol. 41, № 5, pp. 409-433.

[2] Yu.F. Batrakov, R.V. Bogdanov, E.V. Puchkova, and A.S. Sergeev. Radiochemistry (English Translation of Radiokhimiya), 2000, Vol. 42, № 2, pp. 106-112.

[3] R.V. Bogdanov, E.V. Puchkova, N.G. Parnikov, and A.S. Sergeev. Radiochemistry (English Translation of Radiokhimiya), 2011, Vol. 53, № 6, pp. 651-661.

[4] R.V. Bogdanov, Yu.F. Batrakov, E.V. Puchkova, and A.S. Sergeev. Scientific Basis for Nuclear Waste Management, XXV. Ed.: B.P. McGrail, G.A. Cragolino. Boston, USA, 2002, pp. 295.

**METHODS OF QUALITY CONTROL OF Sr-82 ACTIVE
PHARMACEUTICAL INGREDIENT (API)**

**A.S. Bolonkin, A.V. Dunin, K.A. Murashin, N.A. Nerozin, N.P. Togaeva,
S.V. Khamyanov, V.V. Shapovalov**

*State Scientific Centre of the Russian Federation – Institute for Physics and
Power Engineering named after A.I. Leypunsky; Bondarenko Sq., 1, Obninsk,
Kaluga Region, 249033, Russia; e-mail: si@ippe.ru*

Two complementary methods of ^{82}Sr , daughter ^{82}Rb , and possible radioactive impurity concentrations control in ^{82}Sr API, a raw material for $^{82}\text{Sr}/^{82}\text{Rb}$ generator production, have been developed. ^{82}Rb , the eluate from $^{82}\text{Sr}/^{82}\text{Rb}$ generator, is a radiopharmaceutical used in positron emission tomography for cardiovascular disease diagnostics.

^{82}Sr is obtained by irradiation of targets made of metal rubidium of natural isotopic composition. The main radionuclide impurities here are ^{83}Rb , ^{84}Rb , ^{86}Rb , ^{75}Se , ^{74}As , which can be radiochemically separated. Amount of ^{85}Sr is not large in this case, and ^{90}Sr , an extremely unwanted long-lived isotope, is absent. It is a pure beta-emitter together with ^{90}Y , its daughter.

The first method is based on semiconductor γ -spectrometry. Two-channel γ -spectrometry system of “Canberra Industries, Inc.” with detectors of GL and GC series with high-purity germanium is used as measuring equipment, which also allows control the X-ray energy range. Samples for measurements present either 0.1-10ml solutions placed in vials or point sources prepared by solution evaporation on a substrate. The method allows determine a concentration activity of target isotopes $^{82}\text{Sr}/^{82}\text{Rb}$ in the range from 10^3 to 10^7Bq with not more that 10% total error of the measuring result as well as possible impurity radioisotopes in activity range from 10^3 to 10^5Bq with not more that 30% total error of the measuring result.

The second method is based on mass-spectrometry. Measuring equipment is a quadrupole inductively coupled plasma mass-spectrometer NEXION 300D. Conventional mass fractions of strontium isotopes and impurity elements in solutions are determined by direct measurements of their mass-spectra. Strontium isotopes mass fractions range from 0.1% to 99.0 %. It is shown how to determine ^{82}Sr by mass-spectrometry in the presence of ^{85}Rb isobar line.

Results of analysis are used both in the development of ^{82}Sr recovery technology and further in control of routine radiochemical operations.

This work has been performed under financial support of the Ministry of Education and Science of the Russian Federation.

**DETERMINATION OF URANIUM, THORIUM AND TRITIUM IN
DRILLING FLUIDS WITH A HIGH CONTENT OF SALTS, OIL AND
POLYMERS**

L.G. Bondareva

*Siberian Federal University, Krasnoyarsk, Russia, Svobodny prospect, 79,
lydiabondareva@gmail.com*

Naturally occurring radionuclides are present at varying concentrations in the Earth's crust and can be concentrated and enhanced by processes associated with the recovery of oil and gas.

Radioactive materials such as Uranium and Thorium were incorporated in the Earth's crust when it was formed; these normally exist at trace (parts per million – ppm) concentrations in rock formations. Decay of these unstable radioactive elements produces other radionuclides that, under certain conditions (dependent upon pressure, temperature, acidity *etc*) in the subsurface environment are mobile and can be transported from the reservoir to the surface with the oil and gas products being recovered. It is very difficult to determine the radionuclides in the backdrop of significant salt content without the use of long-term methods of separation and subsequent concentration. The sources of tritium are underground nuclear explosions, which took place in the second half of the last century. Dilution method in this case does not help. The purpose of the study was developed testing systems for the determination of uranium, thorium, and tritium in drilling fluids that contain large amounts of salts, as well as oil and polymers.

The objects of study were drilling water of the Vankor's oil field and drilling water from the fields of the Yakutia. We have been used to determine the tritium by liquid scintillation spectrometry and to detecting elements - mass spectrometry with inductively coupled plasma.

We have developed equipment that allows managed with little or no change in physical properties of the fluids separate the main salt matrix (inorganic salts, trace of oil and polymers) of determined elements (gross of uranium, thorium) and radionuclides (isotopes of uranium, tritium).

When we developed the use of the equipment has been significantly improved detection limit of uranium 20 ng/L, thorium 10 ng/L, tritium - 1 Bq/L (with efficiency of 34%).

COLLOID-STABLE SELECTIVE SORBENTS FOR CESIUM AND STRONTIUM UPTAKE

**S.Yu. Bratskaya¹⁾, V.V. Zheleznov¹⁾, D.V. Marinin¹⁾, R. Koivula²⁾,
R. Harjula²⁾, A. Musyanovych³⁾, A. Synytska⁴⁾, F. Simon⁴⁾,
V.A. Avramenko¹⁾**

*¹⁾ - Institute of Chemistry, Far-Eastern Branch, Russian Academy of Sciences
159, Prosp. 100-letya Vladivostoka, Vladivostok 690022, Russia
sbratska@ich.dvo.ru*

²⁾ - University of Helsinki, Helsinki, Finland

³⁾ - Max-Planck-Institute for Polymer Research, Mainz, Germany

⁴⁾ - Leibniz-Institute for Polymer Research, Dresden, Germany

Here we discuss a promising approach to prevent spreading of radioactive materials from contaminated surfaces via formation of stable impermeable polymeric films, which are able to trap radionuclides selectively and significantly reduce their mobility in the environment. The approach is based on immobilization of nanosized selective inorganic sorbents (transition metal ferrocyanides, tetravalent oxides, barium/calcium sulfates etc.) into film-forming latexes. Commercial siloxane-acrylate latex (Scientific-Production Association "Astrokhim", Elektrostal, Moscow Region, Russia) and a series of poly(siloxane) latexes with particle size 108 ± 10 nm varying in content of surface functional groups (carboxylic or amino groups) were used for immobilization of selective sorbents. It was shown that transition metal ferrocyanides could be synthesized directly in the presence of latex particles using carboxylic functional groups as anchoring centers for divalent metal ions sorption and further growth of ferrocyanides nanocrystals. The content of surface functional groups has been identified as a crucial parameter affecting stability of the materials.

The effects of composition, pH, and media salinity on the sorption properties of the selective sorbents immobilized in latex particles toward ^{137}Cs , ^{63}Ni , and ^{90}Sr have been investigated. The dust-suppressing formulations with different latex solid contents varying in composition of latex particles and type of selective sorbents were prepared. Conditions of coatings formation by spray-drying method were optimized via variation of number of pushes, distance from the surface, and solid content of latex in dispersions. Homogeneity, thickness, and topography of the coatings were monitored using SEM, Nanofocus and MicroGlider techniques. It was shown that despite high variations in thickness of spray-dried coatings, the full surface coverage was reached after spraying latex dispersions with solid content $>5\%$ and drying for 3-6 h. Efficiency of coatings to prevent radionuclides spreading was investigated in leaching tests on contaminated quartz sand. It was shown that the degree of radionuclides leaching from uncoated sand and sand coated with latex dispersions reached up to 80% after 6 h of contact with leaching solution, while immobilization of selective sorbents into the latex allowed reducing radionuclides leaching from coated surface to $<1.5\%$.

THE INFLUENCE OF A SURFACE CHEMISTRY OF DETONATION NANODIAMONDS ON SORPTION PROPERTIES AGAINST CATIONS OF RADIONUCLIDES

**Yu.P. Buchatskaya¹⁾, A.Yu. Romanchuk¹⁾, A.A. Shiryaev²⁾, I.I. Kulakova¹⁾,
E.A. Shirshin¹⁾, S.N. Kalmykov¹⁾**

¹⁾ - *Lomonosov Moscow State University, Moscow, Russia*

²⁾ - *Frumkin Institute of Physical Chemistry and Electrochemistry of RAS,
Moscow Russia*

julia.buchatskaya@gmail.com

Detonation nanodiamonds (DND) are potentially promising candidate for sorption applications due to their unique properties: high surface area, highly developed surface, low weight, chemical and radiation resistance. The oxygen-containing groups on the DND surface are responsible for the cation-exchange properties. It was shown before, that DND can effectively remove radionuclide cations from solutions [1].

The purpose of this work is to establish the effect of surface functionalization of DND on sorption properties. In our experiments different DND were used: pristine sample (ND), produced at the Special Construction-Technological Bureau "Technolog" of Saint-Petersburg State Institute of Technology (Technical University) (Russia) and two samples ND-ox and ND-red, treated with acids and hydrogen respectively. The surfaces of ND, ND-ox and ND-red were characterized by IR spectroscopy and XPS. The values of ζ -potential at different pH of the suspensions were measured using Dynamic Light Scattering. The surface groups of the samples were titrated using Boehm technique.

U(VI) speciation was studied using time-resolved laser-induced fluorescence spectroscopy (TRLIFS): the existence of a single fluorescent U(VI) complex sorbed onto ND surface was shown. The sorption of radionuclides showed to be effected by surface chemistry of DND. Fig. 1 shows dependence of Am(III) sorption on initial and modified ND samples.

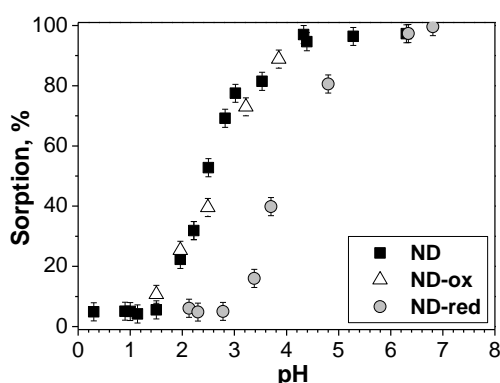

Fig. 1. pH-sorption edge Am(III) sorption onto ND, ND-ox and ND-red samples.

The work was funded by Russian Basic Research Foundation (12-03-31370).

[1] Yu. P. Buchatskaya et al. Proc. of 42èmes Journées des Actinides and 9th School on the Physics and Chemistry of the Actinides, Bristol, England, 2012

**URANYL SPECIATION USING TIME-RESOLVED LASER-INDUCED
FLUORESCENCE SPECTROSCOPY:
WHY EXCITATION INTENSITY AFFECTS FLUORESCENCE DECAY
RATE?**

**G.S. Budylin¹⁾, E.A. Shirshin¹⁾, V.G. Petrov²⁾, V.V. Fadeev¹⁾,
S.N. Kalmykov²⁾**

*¹⁾ - Department of Physics, M.V. Lomonosov Moscow State University,
Leninskie Gory, 1, Moscow, 119991, Russia*

*²⁾ - Department of Chemistry, M.V. Lomonosov Moscow State University,
Leninskie Gory, 1, Moscow, 119991, Russia
shirshin@lid.phys.msu.ru*

Time-resolved laser fluorescence spectroscopy (TRLFS) is extensively used to study uranium(VI) speciation in aqueous solutions [1]. This method allows spectral and temporal selection of different uranium(VI) complexes and implies measurement of fluorescence decay curves on a microsecond timescale. It is also known that there is some discrepancy in excited state lifetime values obtained for certain uranyl complexes [2].

Here, we present a model that describes the influence of excitation intensity on uranyl complexes fluorescence decay rate. For typical parameters of laser radiation used in TRLFS experiments (wavelength 266 nm, millijoule pulse energy, nanosecond pulse duration, millimeter beam radius) it can be estimated that the fraction of excited complexes in the irradiation volume is close to unity, and the diffusion on microsecond timescale can lead to collisional bimolecular quenching, thus resulting in the increase of fluorescence decay rate [3]. Therefore, this effect can lead to misinterpretation of fluorescence decay curve parameters and should be taken into account when determining U(VI) speciation via TRLFS.

[1] R. Collins, T. Saito, N. Aoyagi, T. Payne, T. Kimura, T.D. Waite. Applications of TimeResolved Laser Fluorescence Spectroscopy to the Environmental Biogeochemistry of Actinides. *Journal of Environmental Quality*, 2011, v. 40, 732-741.

[2] I. Billard et al., Aqueous Solutions of Uranium(VI) as Studied by Time- Resolved. Emission Spectroscopy: A Round-Robin Test. *Applied Spectroscopy*, 2003, v. 57, №8, pp. 1027-1038.

[3] G. Budylin, E. Shirshin, V. Petrov, V. Fadeev, and S. Kalmykov. Laser-induced fluorescence of uranyl complexes in aqueous solutions: the role of diffusion-controlled excited states annihilation. *Optics Express*, 2013 (accepted).

**RADIONUCLIDES FOR INVESTIGATIONS OF ION TRANSPORT IN
MEMBRANES OF CHEMICAL SENSORS PREPARED BY PULSED
LASER DEPOSITION**

Yu.E. Ermolenko, D.S. Kaliagin, V.V. Kolodnikov, Yu.G. Vlasov

*Saint-Petersburg State University, 199014, Saint-Petersburg, Universitetskaya
nab. 7/9, e-mail: sensor2000@vk5346.spb.edu*

Thin film sensors on the basis of different chalcogenide glasses and polycrystalline materials (TlI-As₂S₃-Ag₂S and HgI₂-AgI-Ag₂S) have been prepared by means of an off-axis pulsed laser deposition technique (PLD). The physical structure and the stoichiometric compositions of the deposited glass layers have been investigated by Rutherford backscattering spectroscopy (RBS) and transmission electron microscopy (TEM). It is shown that the complex stoichiometry of the chalcogenide target materials is maintained in the chalcogenide thin films prepared by PLD. Methods for solid-phase synthesis of Ag₈HgS₂I₆ and chalcogenide glasses were developed and the diffusion coefficients of thallium-204 and mercury-203 isotope were determined for these compounds for the first time. Data on the ionic conductivity and diffusion of thallium and mercury ions were obtained and used to calculate the defect concentration and mobility in these solid electrolytes. Depending on the material system used, these novel thin film sensors possess a high sensitivity towards Hg of 27-29 mV/pHg and 56-59 mV/pTl over a measuring period of more than 200 days. The obtained results are in good agreement with the measurements performed with bulk sensors.

APPLICATION OF ALPHA-SPECTROMETRIC ANALYTICAL METHOD FOR EVALUATION OF NATURAL WATERS ACTIVITY

G.G. Glukhov, E.S. Donyaeva, V.V. Zukau, Yu.V. Nesterova, I.V. Chikova

Tomsk Polytechnic University, Tomsk, Russia, lab31radcontrol@rambler.ru

Nowadays the development of high accuracy methods of uranium isotopes detection in natural and technological waters is vitally important.

Radioactivity of natural waters is conditioned by the presence of natural radionuclides, such as ^{234}U , ^{238}U , ^{210}Po , ^{226}Ra , ^{230}Th and others.

The presence of isotopes of ^{210}Po , ^{226}Ra , ^{230}Th in analyzed samples influences the results of measurements as alpha radiation energies of ^{234}U , ^{238}U and ^{210}Po , ^{226}Ra , ^{230}Th are very close in values and peaks of these isotopes overlap one another. Thus there is necessity to provide preliminary concentration, separation and extraction of radionuclides from the samples [1].

Physical and physical-chemical analytical methods are used in radiochemistry for concentration and separation of radionuclides, coprecipitation method being one of them. Thus the method allows selective detection of uranium isotopes and their more full extraction from natural and technological waters.

The purpose of experimental works was further development and updating of existing methods of measuring volumetric activity of ^{234}U , ^{238}U isotopes in natural waters with mineralization up to 5g/dm^3 with the help of alpha-spectrometric analytical method with radiochemical preparation [1].

During the performance of the experimental works the optimal parameters of the process of electrolytic precipitation of uranium isotopes on the support layer were determined and made it possible to get calculated samples with thin active layer (not more than 50mkg/cm^2) [2] for further calculation of volumetric activity on the alpha spectrometer with a semiconductor detector and data processing of the spectra with the help of "THE PROGRESS" software [1]. The experimental data are given in Table 1.

Table 1. Experimental data

Isotope	Electrolytic precipitation 30 min	Electrolytic precipitation 60 min
^{234}U , Bq	0.0573	1.149
^{234}U , Bq	0.018	1.071
^{238}U , Bq	0.1604	2.869
^{238}U , Bq	0.049	2.1085

According to the data given we should conclude that when natural waters are characterized by the variety of their radionuclide content and physical-chemical peculiarities the development of special methods and approaches is essential to get accurate and comparable data.

References

[1] Bachur A.E. Methods of calculating volumetric activity of ^{234}U , ^{238}U isotopes in natural waters with mineralization up to 5g/dm^3 with alpha-spectrometric analytical method with radiochemical preparation // Federal Unitary Enterprise "All-Russian Research Institute of Minerals", Moscow.

[2] Bachur A.E., Zuev D.M., Gulinin A.V., Manuilova L.I. Spontaneous electrochemical precipitation of uranium and thorium isotopes in radiochemical analysis // Federal Unitary Enterprise "All-Russian Research Institute of Minerals", Moscow.

SORPTION PROPERTIES OF NANOSTRUCTURED POTASSIUM ALUMINOSILICATE

**P.S. Gordienko, S.B. Yarusova, I.A. Shabalin, V.V. Zheleznov,
D.V. Marinin**

*Institute of Chemistry, Far-Eastern Branch, Russian Academy of Sciences
159, Prosp. 100-letya Vladivostoka, Vladivostok 690022, Russia
yarusova@ich.dvo.ru*

Nanostructured potassium aluminosilicate (NSPA) with an agglomerate size of up to 10 μm consisting of spherical nanoparticles of a diameter 10–20 nm and having a multi-level porous structure with pore sizes from 1 up to 100 nm has been synthesized. In accordance with the data of XRD, IR spectroscopy, thermogravimetry, and energy-dispersive X-ray fluorescence analysis, the synthesized sample composition corresponds to the formula $\text{KAlSi}_3\text{O}_8 \cdot 1.5\text{H}_2\text{O}$. The NSPA specific surface area is $105 \pm 5 \text{ m}^2/\text{g}$.

The sorption properties of NSPA with respect to cesium ions in different salt-free and saline systems (in the presence of KCl, NaCl, NaNO_3 , KNO_3 , and NH_4NO_3) were studied under static conditions. The interfacial equilibrium constants were determined using the atomic absorption analysis data and the method of radioactive indicators. It was established that during the cesium ions sorption from solutions without the salt background the maximum distribution coefficient (K_d) value was equal to 15000 mL/g (initial Cs^+ concentration 0.23 mmol/L; solid:liquid ratio 1:15000). Changes in distribution coefficient values depending on the salt background concentration have been studied. It was established that the highest values of the ^{137}Cs distribution coefficient were observed at cesium sorption from sodium nitrate solutions (K_d changes from 700 up to 12000 mL/g along with the NaNO_3 concentration change from 1 up to 0.01 mol/L, respectively). At ^{137}Cs sorption from potassium and ammonium nitrate solutions, the distribution coefficient values decreased substantially.

It was established that the sorbent under study had high kinetic characteristics: the equilibrium state was attained within less than 30–40 min. The cesium sorption was proved to proceed in accordance with ion exchange mechanism. It was found that the sorbent preserves high sorption properties within a broad pH range (from 3 up to 13).

The cesium strontium isotherms were built. According to the atomic absorption spectroscopy data, the maximum sorption capacity for cesium carbonate solutions in the Cs^+ concentration range from 0.08 up to 28 mmol/L was equal to 2.5–3 mmol/g. At sorption from cesium nitrate solution, the maximum cesium content in the sorbent determined using the methods of atomic emission spectroscopy with inductively coupled plasma and mass spectrometry with inductively coupled plasma was equal to 34.5 wt. %. The Langmuir constants were calculated for all the sorption isotherms.

It has been concluded that the sorbent can be applied for decontamination of different solutions from cesium ions and radionuclides under static conditions.

MICROWAVE METHOD OF OPENING SOLID SAMPLES FOR CARRYING OUT RADIOCHEMICAL ANALYSIS

M.M. Hahunova

FSUE «RADON» Moscow, E-mail: mmhahunova@mail.ru

Despite more than 10 years of fame, the use of the microwave method in radiochemical technologies is very sporadic. The test technological preparatory process of such samples as soot, ash, compounds, immobilized radionuclides after the high-temperature methods of conditioning has n't been performed till now.

During the preparation of solid samples for radiochemical analysis the comparative study of the microwave and «classic» acidic decomposition was done. For creating the technology of the microwave method of opening solid technological samples containing radionuclides the following tasks were solved: the selection of solution structure for the full acidic decomposition of samples, the study of the temperature-time modes of microwave decomposition of samples, ensuring the complete transformation to the solution of all determined radionuclides.

The object of the study was ash residue from the combustion of solid radioactive waste. Ash residue is created during the burning in the installation «Fakel» with iron grid-iron lattices at 9000C, it is not conditioned product of processing. Judging by its morphology and granulometry, ash residue is a heterogeneous radiationally dangerous dusting material containing up to 98% of the radionuclides of incinerated radioactive waste. For technologies of further conditioning the establishment of its radionuclide composition is necessary.

During the creation of the microwave method of opening samples acid dissolution was used with the help of microwave system ETHOS PLUS High Performance Microwave Labstation («Milestone», Italy, from 10 autoclaves HPR - 1000/10S (Teflon reaction chambers, the internal volume - 100 ml, operating pressure 100 bar=1.450 psi =69кПа, temperature up to 2400 C, power up to 1000W). The autoclave for the temperature control is equipped with a fiber-optic sensor ATS-400. Intensification of decomposition trials under the action of microwave radiation depends on: speed and uniformity of heating the reaction mixture; over-temperature boiling under increased pressure in the system; heating the solvent in closed pores of the sample; selective heating of components of heterogeneous systems; destruction of the sample at high pressure.

The results of sample preparation of ash residue were compared with three methods: 1 - the classic method of sample preparation: the preparation of acid hoods, decomposition using sand bath, filtering; then, extraction and identification of radionuclides; 2 – concerning the instruction to the system ETHOS PLUS: the specified concentrated acids were added to the dry joint hinges of solid samples. Then the autoclave was gathered, the program of acidic decomposition was settled. It was suggested in the instruction to the system ETHOS PLUS; after that the extraction and determination of radionuclides were hold; 3 - empirically chosen methodology: to dry joint hinges of solid samples concentrated acids selected experimentally were added. Then the autoclave was gathered, then the program of acidic decomposition, empirically chosen, was settled by varying the amount of acids, number and duration of phases; then the extraction and determination of radionuclides were held. It has been found that in the 1st and the 2nd versions of the samples only mobile acid-soluble forms go into the solution. The reproducibility of operations is observed. Full transition from a solid to a liquid phase does not occur, it reduces the accuracy of the analysis. The developed method (option 3), tested on ten samples reduces the number of reagents in 20 times, the mass of the joint hinges in 5 times, increases the accuracy of measurements due to the complete transition of radionuclides from a solid to a liquid phase, shortens the process of sample preparation from a few days up to 1 hour.

RADIOCHEMICAL ANALYSIS OF RADIONUCLIDES: STATUS AND PROGRESS

X. Hou

*Technical University of Denmark, Center for Nuclear Technologies DK-4000
Roskilde, Denmark
E-mail: xiho@dtu.dk*

With increasing request for decommissioning of nuclear facilities, characterization of various wastes is required for evaluation of the radioactivity inventory in various materials and decision making for management of the produced waste. This is carried out by quantitative determination of various radionuclides present in the materials. Among these radionuclides, the determination of pure beta and alpha emitters including ^3H , ^{14}C , ^{36}Cl , ^{41}Ca , ^{55}Fe , ^{63}Ni , ^{90}Sr and some transuranics is the major challenges, because they could not be measured without separation from the matrix of the samples and from all other radionuclides, this entitles them as the radionuclides of difficult to measure.

In addition, the investigation of environmental and geological behaviors of radionuclides for radioecology and repository of nuclear waste also requests to measure various radionuclides in different environmental and geological matrix. In this case, the measurement of long-lived fission products and actinides, such as ^{129}I , ^{99}Tc , isotopes of plutonium and neptunium, is the major challenge.

In the past years, our laboratory has developed various radiochemical analytical methods aiming at characterization of various decommissioning waste by determination of various radionuclides of difficult to measure. Meanwhile we have also improved our analytical methods for determination long-lived radionuclides in the environment, focus on improving the detection limit, automation of analytical operation, and rapid determination. This presentation gives an overview of these analytical methods, mainly on the present status, progress and perspectives.

**POSSIBILITIES OF TIME OF FLIGHT MASS SPECTROMETER WITH
A PULSED GLOW DISCHARGE LUMAS-30 FOR THE DIRECT
ANALYSIS URANIUM OXIDE**

I.S. Ivanov, A.A. Ganeev, A.S. Andropov

Lumex ltd 70, bld.2, Obukhovskoy Oborony pr., St. Petersburg, Russia,192029

At present, the nuclear industry for the purposes of analysis of spent nuclear fuel used various methods of mass spectrometry, primarily thermal ionization mass spectrometry (TIMS) and ICP MS. In the present study to analyze samples of spent nuclear fuel was first used mass spectrometer system with a pulse glow discharge (GD MS). Studies were conducted samples exhaust oxide (UO_2) mass spectrometer Lyumas -30. It should be noted that it may be used for direct elemental and isotope analysis of solid samples and solutions microvolumes (dry solution residues) . Has been shown to be highly effective spray uranium oxide and a relatively low intensity of the component UO^+ , the presence of which may impair the analytical characteristics of the mass spectrometer for determining transuranic. The mass spectrum obtained as a result of research. Compared mass spectra obtained with different cathodes made of Nb and Al. Further studies are planned with samples of nitride fuel.

**THE REMOTE SEARCH FOR GAMMA SOURCES AND
DETERMINATION OF THEIR DOSE RATES AT THE DRY STORAGE
UNIT 3A IN ANDREEVA BAY DURING ACTIVITIES FOR
IMPROVEMENT TO THE RADIOLOGICAL ENVIRONMENT**

**K.E. Ivanov¹⁾, A.P. Varnavin¹⁾, A.V. Korolev¹⁾, B.S. Stepenov¹⁾,
A.K. Sukhoruchkin¹⁾, Yu.A. Teterin¹⁾, A.Yu. Teterin¹⁾, V.V. Kharitonov¹⁾,
V.A. Selishev¹⁾, A.N. Fedoseenkov¹⁾, A.N. Krasnoshekov²⁾, A.S. Kosnikov²⁾,
D.A. Kostikov²⁾**

¹⁾- NRC "Kurchatov Institute", 1, Kurchatov sq., Moscow 123182 Russia

*²⁾- NWC "SevRAO"- Branch of FSUE "RosRAO", Andreeva Bay, Murmansk
Region, Russia*

The remotely controlled replacement of the concrete covering of the spent fuel dry storage unit 3A with new iron horizontal biological shielding was carried out during works aimed at improvement of the radiological environment at the NWC "SevRAO"- Branch of FSUE "RosRAO", Andreeva Bay, Murmansk Region. Video control systems, BROKK robotic manipulator, HIAB manipulator crane, gamma detectors of the ASCRO radiation monitoring system and CARTOGAM gamma camera were employed in this work. The CARTOGAM gamma camera was used at all work stages for remote search of the most dangerous gamma-radiation sources and for evaluation of their dose rates.

Gamma detectors of the ASCRO radiation monitoring system were located in several spots of the DSU 3A in order to control the radiation situation. This allowed making a qualitative comparison of the ASCRO and the CARTOGAM data. These data agree and describe the radiological situation at the DSU 3A site quite reasonably. The use of the ASCRO and CARTOGAM allowed avoiding an unauthorized exposure of personnel involved in the operations at the DSU 3A. A comparative quantitative and qualitative analysis of efficiency of the conducted work was performed. Further planning of SNF removal works was provided for.

SELECTIVE INITIATION OF CHEMILUMINESCENCE BY LASER-INDUCED EXCITATION OF LANTHANIDE AND ACTINIDE IONS IN AQUEOUS SOLUTIONS

**I.N. Izosimov¹⁾, N.G. Firsin²⁾, N.G. Gorshkov²⁾, V.A Mikhalev²⁾,
S.N. Nekhoroshkov²⁾**

¹⁾ – Joint Institute for Nuclear Research, 141980, Russia, Moscow region, Dubna, Joliot-Curie 6

²⁾ – Klopın Radium Institute, 194021 Russia, St. Petersburg, 2nd Avenue Murinsky, 28, nfirsin@mail.ru

Lanthanide or actinide analysis interest is to use advantages of luminescence procedure for detection of lanthanides and actinides having no self-luminescence, as an example, by initiation of luminescence of some agents through excitation of lanthanide or actinide element to be detected. An effort was made on initiation of luminol chemiluminescence through excitation of lanthanide and actinide ions with laser radiation [1, 2]. Previously we showed a possibility of luminescence excitation in aqueous actinide-containing solutions, among them having no self-luminescence, by irradiation with nitrogen laser [1]. In this case chemiluminescence is caused by oxidation of luminescent agent (luminol) with hydroxyl radicals generated in deexcitation of excited actinide complexes. This chemiluminescence is not selective and proceeds at the background of luminol photoluminescence, therefore necessary to use time-resolution (TR) of analytical luminescence signal.

Chemiluminescence can be initiated selectively when using the absorption bands in visible range caused by transitions within the inner 5f electrons of actinide ions or 4f electrons of lanthanide ions. In this case chemiluminescence can be initiated only in absorption of two or more quanta of laser radiation since the energy of one light quantum in visible range is insufficient for chemiluminescence initiation.

In this work the details of luminol chemiluminescence initiation through excitation of Sm(III), U(IV) and Pu(IV) ions with laser radiation are presented. Data on luminol chemiluminescence in solutions containing Sm(III), U(IV) and Pu(IV) are discussed. Chemiluminescence was induced by two-quanta excitation of lanthanide or actinide ions in the range of 4f or 5f electron transitions by the scheme *two steps-one color*, i.e. in irradiation of actinide-containing solution by one laser and by the scheme *two steps-two colors*, when a solution is irradiated by two lasers operating at different wavelengths. These techniques allow using highly sensitive chemiluminescence procedure for selective detection of various valence lanthanide or actinide species in solutions based on individual features of their absorption spectra

The experiments were performed on an installation involving a pulse nitrogen laser OBB 1010 with a pulse length of 1 ns and a pulse power of approximately 1.4 MW and two tunable dye lasers OBB 1011 and OBB 1012 with a pulse length of 1 ns and 800 ps respectively. The pulse power 300 kW was reached for dye lasers. A delay time for luminescence registration was 2 μs.

References

- [1] I.N. Izosimov et al., *Proc. Int. Conf. Actinides 2005*, Manchester, UK, 2005, p.779.
[2] N.G. Gorshkov et al., *Radiochemistry*, **6**, 525 (2012).

THE COBALT-57 RADIONUCLIDE AS AN EMISSION MÖSSBAUER SPECTROSCOPIC PROBE FOR STUDYING CATION-BINDING SITES IN SOPHISTICATED BIOMOLECULES

A.A. Kamnev¹⁾, Yu.D. Perfiliev²⁾, L.A. Kulikov²⁾

¹⁾ – *Laboratory of Biochemistry, Institute of Biochemistry and Physiology of Plants and Microorganisms, Russian Academy of Sciences, 13 Prospekt Entuziastov, 410049 Saratov, Russia; aakamnev@ibppm.sgu.ru*

²⁾ – *Laboratory of Nuclear Chemistry Techniques, Division of Radiochemistry, Department of Chemistry, M.V. Lomonosov Moscow State University, 1/3 Leninskie Gory, 119991 Moscow, Russia; perf@radio.chem.msu.ru*

The ⁵⁷Co radioisotope (with a half-life period of 9 months) is one of the radionuclides most widely used in the highly sensitive and informative technique of emission Mössbauer spectroscopy (EMS), with applications largely in materials science and nuclear chemistry. Its nuclear decay proceeding via electron capture (EC) gives the stable ⁵⁷Fe isotope which, by the moment of γ -quantum emission ($\sim 10^{-7}$ s after the EC), appears in virtually the same structural microenvironment as the parent ⁵⁷Co ion and thus features the latter via the Mössbauer parameters. However, the ⁵⁷Co \rightarrow ⁵⁷Fe nuclear decay is accompanied by physical and chemical after-effects. They can complicate the resulting emission Mössbauer spectra but, on the other hand, can provide valuable additional information on the electron-acceptor properties of the proximal coordination environment of ⁵⁷Co ions in the sample and on other processes [1].

Applications of the ⁵⁷Co EMS technique in biology-related fields have so far been rare, primarily owing to the necessity of using ⁵⁷Co-containing radioactive compounds in samples under study [2]. However, cobalt as a trace biogenic element is a cofactor in a number of enzymes. In our earlier work, for the first time we successfully realised the idea of substituting ⁵⁷Co²⁺ (as an EMS-active probe) for native cations at cation-binding sites (CBS) within the enzyme active centres, using glutamine synthetase (GS) as a model metalloenzyme [3, 4]. The resulting emission spectra showed separate contributions from the two structurally different CBS present in each GS active centre (there are 12 identical active centres per dodecameric GS molecule). We further applied ⁵⁷Co EMS to probing ⁵⁷Co²⁺-doped GS covalently modified by adenylation, as well as in the presence of Mn²⁺ as an additional EMS-“invisible” cofactor. The emission spectra showed Mn²⁺-induced ⁵⁷Co²⁺ redistribution between the two CBS and changes in the ⁵⁷Co²⁺ coordination related to GS activity regulation. (Supported in part by the Russian Foundation for Basic Research, Grant # 13-04-01538-a.)

[1] Perfiliev Yu.D., Rusakov V.S., Kulikov L.A., Kamnev A.A., Alkhatib K. *J. Radioanal. Nucl. Chem.* 266 (2005) 557-560.

[2] Kamnev A.A. *J. Mol. Struct.* 744-747 (2005) 161-167.

[3] Kamnev A.A., Antonyuk L.P., Smirnova V.E., Serebrennikova O.B., Kulikov L.A., Perfiliev Yu.D. *Anal. Bioanal. Chem.* 372 (2002) 431-435.

[4] Kamnev A.A., Antonyuk L.P., Smirnova V.E., Kulikov L.A., Perfiliev Yu.D., Kudelina I.A., Kuzmann E., Vértes A. *Biopolymers* 74 (2004) 64-68.

**SOLVENT EXTRACTION AND EXTRACTION CHROMATOGRAPHY
ISOLATION AND SEPARATION OF Am(III), Pu(IV,V), Np(V) AND
Eu(III) WITH MACROCYCLIC COMPOUNDS**

**A.Sh. Madumarov, A.A. Abramov, A.N. Vasiliev, V. Kovalev,
A.M. Vatsuro, P.G. Mingalev, O.V. Dubovaya, G.V. Lisichkin**

*Lomonosov Moscow State University, Chemistry department, Moscow, Russia,
e-mail: aaa2745@yandex.ru*

Solvent extraction of Am(III), Pu(IV,V), Np(V) and Eu(III) with various calixarenes modified by carbamoylmethylphosphine oxide groups (CMPO) in the upper and lower rims from nitrate, sulphate, picrate and 2-adamantyl-2-sulfanylethanoic acid solutions [1] were studied. Chloroform, dichloroethane, as well as various mixtures of inert organic compounds were used as organic solvents.

The highest distribution ratios for Am(III) were obtained using calix[4]arene modified in the upper rim by four CMPO moieties and in the lower rim by pentyl radicals to prevent the possible conformations (V-460). The best separation factors of americium from other studied elements were achieved from nitric acid solutions or solutions of 2-adamantyl-2-sulfanylethanoic acid which are competitive with 3 M HNO₃, with own concentration of 10⁻³-10⁻² M [2].

For the separation of all studied elements an extraction-chromatographic behavior of the studied radionuclides was investigated. A sorbent based on C-120 silica gel matrix, activated by amino groups, and then grafted by calixarene V-460 through brominated pentyl radicals was synthesized for this purpose. Macrocyclic was associated with amino groups through a single (C-120γNH₂K₁) or two alkyl radicals (C-120γNH₂K₂). Sorption of radionuclides in static and dynamic conditions from the solutions of nitric acid and 2-adamantyl-2-sulfanylethanoic acid with different concentrations was investigated. Based on these data the extraction-chromatographic separation of the elements was studied.

[1] A. Shmailov, L. Alimbarova, I. Vatsouro, V. Tafeenko, E. Shokova and V. Kovalev, First synthesis of α-(3-R-1-adamantyl)sulfoacetic acids and their derivatives // Tetrahedron, 2012, 68, 4765.

[2] Alexander A. Abramov, Aleksandr N. Vasiliev, Olga V. Dubovaya, Vladimir V. Kovalev and Ivan M. Vatsouro, Extraction of americium(III), plutonium(IV, V) and neptunium(V) with calixarenes // Mendeleev Communications, 2012, 22, 1–3.

SORPTION OF STRONTIUM RADONUCLIDES FROM SEAWATER

**D.V. Marinin, V.V. Zheleznov, I.V. Sheveleva, T.A. Sokolnitskaya,
E.V. Kaplun, V.A. Avramenko**

*Institute of Chemistry, Far-Eastern Branch, Russian Academy of Sciences
159, Prosp. 100-letya Vladivostoka, Vladivostok 690022, Russia
dmarinin@ich.dvo.ru*

The development of nuclear power industry and nuclear technologies resulted in contamination of biosphere, including seawater areas and World Ocean at large, by various radionuclides. Radionuclide accumulation in seabed deposits and migration comprise a great danger for vital functions of different organisms. Strontium radionuclides belong to the group of toxic elements, which causes the necessity as to control their release into the environment as to improve the methods and approaches of their removal from water streams.

The problem of removal of long-lived highly toxic radionuclides can be solved through application of sorption methods, which are primarily used, due to their simplicity and efficiency, to remove dissolved radionuclides down to the level acceptable for decontaminated water disposal into the environment. The efficiency of radionuclide removal depends on the sorbent selectivity in the presence of different components contained in an aqueous medium.

The strontium sorption by barium-containing sorption-reagent materials has been studied and respective sorption mechanisms have been examined. The strontium sorption was also tested for composite barium-containing sorbents based on carbon fibers used as a matrix in sorbent synthesis. The effect of composite synthesis conditions on their sorption properties was demonstrated.

The comparison of strontium radionuclide sorption from seawater by different types of sorbents was performed. The advantages of the sorption-reagent materials obtained in the present work for strontium radionuclide removal from seawater, as compared to other tested sorbents, have been demonstrated.

**SPECTROPHOTOMETRIC METHOD OF PRECISE
DETERMINATION OF URANIUM, PLUTONIUM AND OTHER
RADIONUCLIDES IN SOLUTIONS BY SERIAL EQUIPMENT**

D.L. Mialochkin, T.D. Gogoleva

*V.G. Khlopin Radium Institute,
194021, S.-Petersburg, 2-nd Murinskiy Prospect, b. 28,
lab0062@yandex.ru*

Precise determination of radioactive elements, such as uranium and plutonium, with repeatability standard deviation (relative form) $S_r < 0,1\%$ can guarantee non-proliferation of nuclear materials. Along with generally accepted methods, this task may be accomplished by using a spectrophotometric method in photometric mode of operation on serial spectrophotometric equipment, in particular Shimadzu UV.

In our recent studies we pointed out that, besides multiple repeated scan spectra, applying of internal standardization principle is alternative way to increase spectrophotometric measurements precision [1-4]. Auto-zero function, that usually exists at serial equipment, permanently keeps the track of baseline (100% light transmission) This provides internal standardization in spectra and optical density measurement of solutions. Multiple photometric measurements (1 to 300 times per operation) of the optical density at selected wavelengths allows to determine concentration of elements in solutions with relative repeatability standard deviation $< 0,1\%$.

Precise determination results for uranium, plutonium, ruthenium, erbium, gadolinium, samarium, rhenium and technetium in pure solutions by spectrophotometry in photometric mode of operation were obtained with $S_r = 0,02 - 0,1\%$

Serial equipment also provides more precise control of spectrophotometric analysis optimal conditions, such as temperature and acidity of solutions.

Precise spectrophotometric method allows to accomplish tasks, mainly related to manufacturing and (or) certification of standard samples - radioactive tracer solutions of U-233 or Pu-242 with specified mass fraction. Also this method can be applied for accounting and control of nuclear materials.

[1] A.V. Stepanov, S.A. Nikitina, V.T. Karasev // Radiochemistry. 2002. V. 44, № 2, p. 165-169.

[2] A.V. Stepanov, S.A. Nikitina, V.T. Karasev, D.A. Stepanov, M.V. Penkin, A.B. Bogoroditski, E.V. Pevtsova // Proceeding of the khlopin radium institute, V. X, 2003, p. 50-58.

[3] A.V. Stepanov, D.A. Stepanov, S.A. Nikitina, V.T. Karasev // Radiochemistry, 2006. V. 46, № 2, p. 179-184.

[4] A.V. Stepanov, M.G. Grigorjeva, T.D. Gogoleva, Yu.A. Panteleev, S.A. Nikitina // Proceedings of the Khlopin radium institute, 2007 V. 12, p. 103-110.

**TRITIUM LABELED COMPOUNDS IN NANODIAMONDS
MODIFICATION**

I.Yu. Myasnikov, M.G. Chernysheva, G.A. Badun

*Dpt. Chemistry, Lomonosov Moscow State University, Moscow, Russia 119991
E-mail: myasnikov751@gmail.com*

Diamonds with 2-10 nm diameter because of its low toxicity for different types of cells, is gaining increasing attention in medical applications. To provide biological compatibility to carbon based nanomaterial the covalent and the noncovalent attachment of organic compounds are widely applied. The use of radiolabeled compounds allows not only to expand an operating range of compound concentrations that determined by molar radioactivity of labeled compound, but also to expand the scope of objects from low molecular weight drugs to biopolymers. Tritium label itself provides high specific radioactivity, and the possibility of application of tritium thermal activation technique allows radiolabel introduction in different organic compounds. In present research adsorption of biologically active compounds on the surface of detonated nanodiamonds (NDs) was studied by means of radiotracer method. Lysozyme, albumin, coal humic acids, homopantothenic acid and benzyldimethyl[3-(myristoilamine)propyl]ammonium chloride monohydrate commercially available as Miramistin[®] were used as adsorbates.

In the adsorption experiments NDs were used either as a powder or as a preliminary prepared suspension. In the first case an aqueous solution of tritium labeled compound was added to NDs sample and sonicated to prepare a suspension with small particles. In the second case NDs were subjected to sonication in water to prepare stable suspension following by the addition of the solution of tritium labeled compound. After 2 days incubation at 25°C suspensions were centrifuged and radioactivity of supernatant was measured. If the adsorption exceeds monolayer level it was possible to calculate binding as a deferens between the initial and equilibrium concentrations of the solution. Otherwise, when adsorption was at monolayer level or less, the radioactivity of sediment was directly measured.

The stability of NDs-adsorbate conjugate and aggregative stability of solid particles in aqueous suspensions were determined.

The peculiarities of both experimental procedures and the results obtained for biomacromolecules and low molecular weight drugs are discussed in the report.

AUTOMATED MULTI-SAMPLE ANALYSIS FOR SIMULTANEOUS DETERMINATION OF TECHNETIUM, NEPTUNIUM, PLUTONIUM AND URANIUM IN LARGE-SIZED SEAWATER

J. Qiao¹⁾, K. Shi²⁾, X. Hou¹⁾

¹⁾ – Center for Nuclear Technologies, Technical University of Denmark, DTU Risø Campus, DK-4000 Roskilde, Denmark

²⁾ – Radiochemistry Lab, School of Nuclear Science and Technology, Lanzhou University, 730000, Lanzhou, China

A flow injection (FI) based analytical method was developed for simultaneous determination of technetium, neptunium, plutonium and uranium in large-sized (200 L) seawater samples. Ion hydroxide co-precipitation was used for the preliminary sample treatment which provided the merit of simultaneous pre-concentration of the entire target radionuclides. Automated extraction and/or anion exchange chromatographic separations were thereafter performed within the delicate FI system for further purification of each analyte. Four samples could be parallelly processed in the FI system whereby the labor intensity was reduced to a significant extent compared with the conventional analytical methods performed manually. Analytical results indicate that the proposed method is robust and straightforward, providing satisfactory chemical yields (60-80%) with adequate accuracy and highly improved sample throughput. The unique feature of multi-radionuclide and multi-sample simultaneous processing vitalizes the developed method as a powerful analytical tool to issue reliable analytical data in a timely manner with reduced sampling and labor costs in both radioecology studies and emergency preparedness.

T-55 SORBENT FOR RADIOCHEMICAL ANALYSIS AND LIQUID RADIOACTIVE WASTES TREATMENT

V.S. Semenishchev, A.V. Voronina

Ural Federal University, Russia, Ekaterinburg, vovius82@mail.ru

Due to extension of atomic energy in Russia and planning of realization of closed nuclear fuel cycle, problems of liquid radioactive wastes treatment and immobilization of radionuclides become more important. The method of synthesis of surface modified nickel-potassium ferrocyanide based on hydrated titanium dioxide (T-55 sorbent) for concentration of caesium from aqueous media is developed by Radiochemistry and Applied Ecology chair of UrFU.

Comprehensive tests of T-55 sorbent using physical-chemical methods of analysis as well as determination of its sorption features are made. It is shown that the sorbent possesses high radiation and chemical stability, high porosity and specific area, selectivity to Cs, specificity to Sr, U, Th. The main features of the sorbent are presented at table 1.

Table 1. The main features of the T-55 sorbent

Feature	Value
Distribution coefficient of Cs from tap water, mL g ⁻¹	(4,0±1,0)·10 ⁵
Distribution coefficient of Sr from tap water, mL g ⁻¹	(1,0±0,2)·10 ³
Static exchange capacity of Cs, mg g ⁻¹	270
Static exchange capacity of Sr, mg g ⁻¹	34
Integral leaching rate of Cs from saturated sorbent, g cm ⁻² day ⁻¹ : still water	3,3·10 ⁻¹¹
Integral leaching rate of Sr from saturated sorbent, g cm ⁻² day ⁻¹ : still water	8,2·10 ⁻¹²
tap water	5,4·10 ⁻¹²
Specific area, m ² g ⁻¹	120 – 150
Thermal stability	Up to 150 °C

It is shown that the T-55 sorbent can be used for preconcentration and separation of caesium with the aim of radiochemical analysis of various samples for Cs radionuclides. The sample was previously acidified to pH 1 – 2 (Sr, U and Th are not sorbed at this pH) and passed through column. Determination of Cs was performed by measurement of either saturated sorbent or eluate (Cs can be eluted by 5M NaOH) via gamma-spectrometry. Chemical yield of Cs is 98±2%.

The performed tests have shown high selectivity of the T-55 sorbent for caesium in low-salinated water as well as in presence of high amounts of analogue cations (Na⁺, K⁺, NH₄⁺). It is shown the possibility of its use for liquid radioactive wastes processing at the wide pH range (e.g. solutions containing up to 7 M HNO₃) for extraction of caesium from high-salinated solutions containing up to 3,5M NaNO₃, up to 1 g L⁻¹ of surfactants and up to 0,1 M EDTA. The sorbent can be used as a matrix for combined immobilization of long-lived β-emitting caesium and strontium radionuclides with the view of their long-term deposition or final burial. Integral leaching rates of Cs and Sr from saturated sorbent samples are presented at table 1. The sorbent allows to simplify the scheme of liquid radioactive wastes processing due to combination of sorption decontamination of liquid phase and immobilization of caesium and strontium radionuclides in the same stage.

The study was supported by The Ministry of education and science of Russian Federation, project 14.A18.21.0313 and by Ural Federal University development program with the financial support of young scientists.

**USE OF RADIONUCLIDE MICROSCOPIC DIAGNOSTICS FOR THE
DETERMINATION OF THE TRANSLATIONAL MOBILITY OF
ATOMS AND OF THE CRYSTAL DEFECTIVENESS**

A.V. Severin

Moscow State University, Chemistry Department, Moscow, 119991
e-mail: severin@radio.chem.msu.ru

Radionuclide diagnostics is a promising and actively developing method for studying physicochemical (in particular, heterogeneous) processes. This method furnishes information on the substance flux into each particle of the solid phase and allows determination of specific structural features of both the external (near-surface) layer of the crystals and of their bulk (defectiveness, block structure, presence of internal cavities, etc.). It is known that, in crystal growth from highly supersaturated media, point defects of the near-surface layers of the growing crystal are “inherited” by its volume owing to “immurement” of the defective layer by the next layer or to aggregation with the formation of a hierarchic block structure of crystals. In the process, point defects interact with each other to form complexes whose lifetime exceeds the lifetime of individual defects.

The specific features of the behavior and interaction of nonequilibrium defects arising in fluctuation growth of gypsum crystals from aqueous solution and the effect of these defects on the self-diffusion coefficients of the crystallizant atoms were revealed by radionuclide microscopic diagnostics using a pair of tracers (^{45}Ca and ^{35}S). In the course of the experiment, the kinetics of the radionuclide transfer from the solution to the solid phase was compared with the mathematical model of the diffusion transfer of radionuclides from a limited volume of the solution into particles of a polydispersed solid and with the pH variation in the course of formation and existence of the solid phase. In the course of gypsum crystal growth, the expanding surface captures the CaOH^+ and HSO_4^- ions which form nonequilibrium vacancies in the anionic and cationic sublattices. Excess defects interact with each other to form on the crystal surface and in its bulk molecular vacancies, dipolons, or are annealed in the course of aging. Dipolons are responsible for high self-diffusion coefficients of the crystallizant atoms. Perfection of the solid phase leads to a decrease in these quantities by two orders of magnitude.

APPLICATION OF CAPILLARY ELECTROPHORESIS WITH UV DETECTION FOR SEPARATION AND DETERMINATION OF ACTINIDES

B. Zubekhina¹⁾, V.A. Babain¹⁾, N.V. Komarova²⁾, M.Ya. Kamentsev²⁾

¹⁾ - *V.G. Khlopin Radium Institute, b.28, 2-nd Murinskiy Prospect, S.-Petersburg, bzubekhina@khlopin.ru*

²⁾ - *Lumex Group of Companies, 70, bld.2, Obukhovskoy Oborony pr., St. Petersburg*

Development of new approaches to analytical support currently is one of the most important areas to stimulate the improvement of the nuclear fuel cycle technologies. The high separation efficiency of capillary electrophoresis makes it a promising method for the analytical control for reprocessing of spent nuclear fuel. However, a detailed study of the applicability of the method of capillary electrophoresis for the analysis of real samples of spent nuclear fuel is not done until now. Due to the high radioactivity all experiments were carried out on model samples or on samples containing actinides at trace level.

In this research the capillary electrophoresis system «Capel-105» (Lumex Group of Companies) with UV-detection has been used for the separation of actinides: uranium (VI), plutonium (IV) and neptunium (V). Model mixture contained 20 mg/L U, 15 mg/L Pu and 15 mg/L Np in 0.1 M nitric acid solution. Component identification was carried out by standard additions method. The separation parameters, such as composition of the background electrolyte, pH, detection wavelength and applied voltage, were selected and optimized. As the background electrolyte some buffer solutions was used - citrate, oxalate, tartrate, phosphate and carbonate. The most stable complexes of actinides observed with oxalate ion, so for further studies the background electrolyte based on sodium oxalate was selected. Background electrolyte pH ranged from 3 to 5, in 0.5 increments. At pH 4.5 the best shape of the peaks observed and the complete separation of the components was achieved in 6.5 minutes. With direct UV detection the maximum absorption is observed in the range 200 - 210 nm. Under selected conditions, the detection limits of 3 mg/L for U (VI) and 5 mg/L for Np and Pu were obtained.

The procedures have been applied to model and real samples from PUREX process. As a real sample the PUREX raffinate from the first cycle had been used. Experimental design is shown in Fig.1.

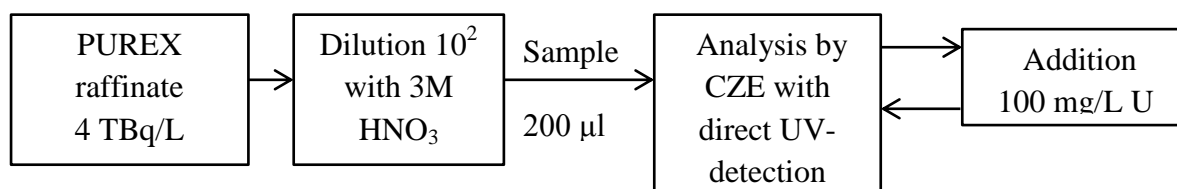

Fig. 1. Experimental design.

The results indicate the possibility of reliable determination milligram level quantities of uranium in samples of SNF reprocessing.

The First Russian-Nordic Symposium on Radiochemistry

<i>Aaltonen I.</i>	49	<i>Butkalyuk I.L.</i>	6
<i>Abramov A.A.</i>	113, 172	<i>Butkalyuk P.S.</i>	6
<i>Abramova A.V.</i>	125	<i>Byegård J.</i>	49
<i>Adamo G.</i>	93		
<i>Adischev Yu.N.</i>	110	<i>Chang C.W.</i>	95
<i>Agaeva A.V.</i>	113	<i>Chekmarev A.M.</i>	16
<i>Alferova A.A.</i>	3	<i>Chen N.</i>	153
<i>Aliev R.A.</i>	103	<i>Chernakova T.A.</i>	7, 26
<i>Altmaier M.</i>	22	<i>Chernysheva M.G.</i>	8, 13, 27, 175
<i>Alyapyshev M.Yu.</i>	69, 80	<i>Chibisov E.V.</i>	101
<i>Andersson P.</i>	49	<i>Chikova I.V.</i>	164
<i>Andreev S.S.</i>	136, 145	<i>Curti E.</i>	33
<i>Andropov A.S.</i>	168	<i>Czerwinski K.R.</i>	19, 25
<i>Androsov A.V.</i>	39		
<i>Arinicheva Y.A.</i>	40, 65	<i>Dardenne K.</i>	22
<i>Arnaud-Neu F.</i>	14	<i>Demidov Yu.A.</i>	9, 21
<i>Aromaa J.</i>	10	<i>Denden I.</i>	19
<i>Arponen E.</i>	10	<i>Dispenza C.</i>	93
<i>Arseenkov L.V.</i>	85	<i>Ditta L.</i>	93
<i>Atamanyuk N.I.</i>	136	<i>Dogadkin N.N.</i>	142
<i>Avramenko V.A.</i>	160, 173	<i>Donyaeva E.S.</i>	164
<i>Avrorin V.V.</i>	3, 28	<i>Drapailo A.B.</i>	15
		<i>Dubovaya O.V.</i>	172
<i>Babain V.A.</i>	5, 69, 80, 179	<i>Dunin A.V.</i>	4, 158
<i>Badun G.A.</i>	8, 13, 27, 28, 175	<i>Dvoyeglazov K.</i>	77
<i>Baklay A.A.</i>	129	<i>Dyakov E.K.</i>	104
<i>Barzakh A.E.</i>	104	<i>Dzhivanova Z.V.</i>	41
<i>Batist L.Kh.</i>	104		
<i>Batusov S.S.</i>	67	<i>Egorova B.V.</i>	76, 94
<i>Beckman I.N.</i>	73, 116, 139	<i>Ekberg C.</i>	33
<i>Belokon Yu.N.</i>	95, 102	<i>Enina D.A.</i>	30, 31
<i>Belova E.V.</i>	41, 42	<i>Ermolaev S.V.</i>	103
<i>Bogdanov R.V.</i>	32, 43, 117, 157	<i>Ermolenko Yu.E.</i>	163
<i>Bogdanova O.G.</i>	137	<i>Evseev A.V.</i>	115
<i>Bolonkin A.S.</i>	4, 158		
<i>Bolsunovsky A.</i>	114	<i>Fadeev V.V.</i>	162
<i>Bondareva L.G.</i>	159	<i>Fan Y.K.</i>	153
<i>Borisova N.E.</i>	80	<i>Fattahi M.</i>	19
<i>Bosbach D.</i>	40, 65	<i>Fedorov D.V.</i>	104
<i>Boytsova T.A.</i>	5	<i>Fedorov Yu.S.</i>	45
<i>Brandt F.</i>	40, 65	<i>Fedorov Yu.V.</i>	94
<i>Bratskaya S.Yu.</i>	160	<i>Fedorova O.A.</i>	94
<i>Bryukhanova K.I.</i>	119	<i>Fedorova O.S.</i>	95, 102
<i>Buchatskaya Yu.P.</i>	161	<i>Fedoseenkov A.N.</i>	169
<i>Budyka A.K.</i>	132	<i>Fedoseev V.M.</i>	116
<i>Budylin G.S.</i>	162	<i>Fellhauer D.</i>	22
<i>Bukaemskiy A.A.</i>	40, 65	<i>Filatova A.M.</i>	104
<i>Bulatov G.S.</i>	39	<i>Filimonenko E.A.</i>	152
<i>Bulone D.</i>	93	<i>Finkeldei S.</i>	65
<i>Burkitbaev L.M.</i>	143	<i>Finnema S.J.</i>	106
<i>Burlaka O.A.</i>	68	<i>Firsin N.G.</i>	44, 170
<i>Burton-Pye B.</i>	19	<i>Florya S.N.</i>	44

The First Russian-Nordic Symposium on Radiochemistry

<i>Forsback S.</i>	96, 98	<i>Ivanov I.A.</i>	124, 136, 149
<i>Francesconi L.</i>	19	<i>Ivanov I.S.</i>	168
<i>Fu Y.C.</i>	153	<i>Ivanov K.E.</i>	30, 31, 169
<i>Ganeev A.A.</i>	168	<i>Ivanov R.A.</i>	13
<i>Gaona X.</i>	22	<i>Ivanov V.</i>	77
<i>Garshev A.V.</i>	119	<i>Ivanov V.K.</i>	24
<i>Gavrichev K.S.</i>	119	<i>Ivanov Yu.A.</i>	122
<i>Gedgovd K.N.</i>	39	<i>Izosimov I.N.</i>	170
<i>German K.E.</i>	19, 62, 84, 146	<i>Johnstone E.V.</i>	19, 25
<i>Gherssi G.</i>	93	<i>Jokelainen L.</i>	121
<i>Gieré R.</i>	117	<i>Jonsson M.</i>	52, 93
<i>Glukhov G.G.</i>	110, 164	<i>Kabanov D.V.</i>	101
<i>Gogoleva T.D.</i>	174	<i>Kaipainen M.</i>	53
<i>Goletsky N.D.</i>	45	<i>Kalchenko V.I.</i>	14, 15
<i>Golubina E.N.</i>	16	<i>Kaliagin D.S.</i>	163
<i>Gorbunov V.A.</i>	46	<i>Kallio S.</i>	126
<i>Gorbunova O.A.</i>	47, 48, 83	<i>Kalmykov S.N.</i>	22, 24, 30, 31, 71,
<i>Gorbunova T.V.</i>	150		76, 94, 103, 119,
<i>Gordienko P.S.</i>	165		123, 124, 149, 161,
<i>Gorshkov N.G.</i>	170		162
<i>Goryachenkova T.A.</i>	118	<i>Kamentsev M.Ya.</i>	179
<i>Gouverneur V.</i>	96	<i>Kamnev A.A.</i>	171
<i>Gracheva N.N.</i>	119	<i>Kankaanpää H.</i>	134
<i>Grimaldi N.</i>	93	<i>Kaplun E.V.</i>	173
<i>Gurzhii V.V.</i>	20	<i>Karavan M.D.</i>	14, 15
<i>Guseva L.I.</i>	97	<i>Kashcheev V.A.</i>	54
<i>Haaparanta-Solin M.</i>	98	<i>Kazinskaya I.E.</i>	118
<i>Hahunova M.M.</i>	166	<i>Kekäläinen P.</i>	49, 60
<i>Hakanen M.</i>	126	<i>Kelley D.</i>	69
<i>Häkkinen J.</i>	60	<i>Kemppainen K.</i>	49
<i>Halldin C.</i>	106	<i>Khamyanov S.V.</i>	158
<i>Hänninen K.</i>	60, 121	<i>Kharchenko S.G.</i>	15
<i>Harjula R.</i>	86, 160	<i>Kharitonov V.V.</i>	169
<i>Heier L.S.</i>	143	<i>Kirakosyan A.</i>	19
<i>Helariutta K.</i>	49, 60	<i>Kirjavainen A.K.</i>	96, 98
<i>Helin S.</i>	10	<i>Kirk C.</i>	147
<i>Holm P.</i>	106	<i>Kiselev Yu.M.</i>	36
<i>Hölttä P.</i>	60	<i>Kizim N.F.</i>	16
<i>Hou X.L.</i>	153, 167, 176	<i>Klochkova N.V.</i>	67
<i>Hubscher-Bruder V.</i>	14	<i>Knuutinen J.</i>	35
<i>Huittinen N.</i>	35	<i>Kochina T.A.</i>	3
<i>Ikäheimonen T.K.</i>	120	<i>Koivula R.</i>	53, 160
<i>Ikonen A.T.K.</i>	127	<i>Kolodnikov V.V.</i>	163
<i>Ikonen J.</i>	49, 121	<i>Koltsova T.I.</i>	64
<i>Ilin V.A.</i>	50	<i>Komarova N.V.</i>	179
<i>Istomin I.A.</i>	51	<i>Konevnik Yu.V.</i>	128
<i>Isupov V.P.</i>	133	<i>Konovalov A.V.</i>	136
<i>Itullina A.</i>	11, 12	<i>Konstantinova L.I.</i>	128
<i>Ivanov I.A.</i>	79	<i>Korolev A.V.</i>	169
		<i>Korzhavin A.V.</i>	145

The First Russian-Nordic Symposium on Radiochemistry

<i>Koskinen L.</i>	49, 60	<i>Marjamäki P.</i>	98
<i>Kosnikov A.S.</i>	169	<i>Martin A.</i>	121, 151
<i>Kostikov D.A.</i>	169	<i>Martynov K.V.</i>	128
<i>Kostylev A.I.</i>	44	<i>Maruk A.Ya.</i>	19
<i>Kovalev V.</i>	172	<i>Mashkin A.N.</i>	62
<i>Krapukhin V.B.</i>	55, 56, 57	<i>Maskalchuk L.N.</i>	129
<i>Krasavina E.P.</i>	55, 58	<i>Maslakov K.I.</i>	30, 31
<i>Krasikova R.N.</i>	95, 99, 102, 106	<i>Maslennikov A.G.</i>	72
<i>Krasnoshekov A.N.</i>	169	<i>Maslennikov Yu.S.</i>	101
<i>Krivitsky A.G.</i>	157	<i>Masyagutova G.</i>	11, 12
<i>Ksenofontov A.L.</i>	27	<i>Mathiessen B.</i>	109
<i>Kudinov A.S.</i>	45	<i>Mattila A.</i>	120
<i>Kulakova I.I.</i>	161	<i>Matyskin A.V.</i>	100
<i>Kulemin V.V.</i>	55, 56, 57, 63	<i>Medvedev V.P.</i>	51
<i>Kulikov L.A.</i>	171	<i>Medvedeva M.</i>	114
<i>Kulyukhin S.A.</i>	17, 55, 56, 57, 58, 59, 63	<i>Melentev A.B.</i>	62
<i>Kuryavyi V.G.</i>	89	<i>Melikhov I.V.</i>	63
<i>Kuva J.</i>	60	<i>Melnik N.A.</i>	130
<i>Kuzmenkova N.V.</i>	123, 124, 149	<i>Menshikh T.B.</i>	131
<i>Kuznetsov R.A.</i>	6	<i>Merkulov V.G.</i>	101
<i>Kuzovkina E.A.</i>	118	<i>Mezilev K.A.</i>	104
<i>Lahdenperä A.-M.</i>	127	<i>Mialochkin D.L.</i>	174
<i>Lapshina E.V.</i>	103	<i>Mikhalev V.A.</i>	170
<i>Lavrikov V.A.</i>	55, 56, 57, 63	<i>Mikheev N.B.</i>	63
<i>Lavrinovich E.A.</i>	125	<i>Miklyaev P.S.</i>	135
<i>Ledovskoy I.S.</i>	44	<i>Mingalev P.G.</i>	172
<i>Lehto J.</i>	35, 126, 127, 147	<i>Minyaeva D.A.</i>	73, 116, 139
<i>Lempinen J.</i>	126, 127	<i>Miroshnikov A.Yu.</i>	141
<i>Leontieva T.G.</i>	129	<i>Miroslavov A.E.</i>	20, 29
<i>Leppänen A.-P.</i>	120, 144	<i>Mishina N.E.</i>	64
<i>Li H.C.</i>	153	<i>Mizina L.V.</i>	59
<i>Lifanov F.A.</i>	46	<i>Modolo G.</i>	40, 65
<i>Lind O.Ch.</i>	140	<i>Mokhodoeva O.B.</i>	88
<i>Lisichkin G.V.</i>	172	<i>Molkanov P.L.</i>	104
<i>Liu Q.</i>	153	<i>Molochnikova N.P.</i>	88
<i>Liu R.S.</i>	95	<i>Moroz F.V.</i>	104
<i>Lomachuk Yu.V.</i>	18, 32	<i>Mosyagin N.S.</i>	21, 36
<i>Lukens W.</i>	19	<i>Murashin K.A.</i>	158
<i>Lumpov A.A.</i>	20, 29, 64	<i>Murzin A.A.</i>	5
<i>Lusa M.</i>	127	<i>Musyanovych A.</i>	160
<i>Lys Y.I.</i>	116	<i>Myasnikov I.Yu.</i>	175
<i>Lyubimov D.Yu.</i>	39	<i>Myasoedov B.F.</i>	41, 42
<i>Madumarov A.Sh.</i>	172	<i>Myasoedova G.V.</i>	88
<i>Maleev V.I.</i>	95, 102	<i>Naumov A.V.</i>	44
<i>Malinina G.A.</i>	61	<i>Nazin E.R.</i>	42
<i>Maltsev D.A.</i>	29	<i>Nekhoroshkov S.N.</i>	170
<i>Mamykin A.</i>	11, 12	<i>Nerozin N.A.</i>	107, 158
<i>Mangione M.</i>	93	<i>Nesterova Yu.V.</i>	164
<i>Marinin D.V.</i>	160, 165, 173	<i>Neumeier S.</i>	40, 65
		<i>Nifant'ev I.E.</i>	76
		<i>Nikitin A.V.</i>	66

The First Russian-Nordic Symposium on Radiochemistry

<i>Nikolaevskiy V.B.</i>	67	<i>Rodin A.V.</i>	41, 42
<i>Nikonov S.A.</i>	85	<i>Rodionov S.A.</i>	45
<i>Nilsson K.</i>	49	<i>Romanchuk A.Yu.</i>	24, 71, 119, 161
<i>Novikov A.P.</i>	70, 118, 125	<i>Rosenkranz A.A.</i>	105
<i>Ogorodnikov B.I.</i>	132, 142	<i>Rosseland B.O.</i>	143
<i>Orlov S.Yu.</i>	104	<i>Rothe J.</i>	22
<i>Orlovskaja V.V.</i>	95, 102	<i>Rotmanov K.V.</i>	72
<i>Oshchepkov M.S.</i>	94	<i>Rumer I.A.</i>	58, 59, 63
<i>Osipov D.I.</i>	136	<i>Rusakov A.A.</i>	21
<i>Ostapenko V.S.</i>	103	<i>Ryabinin M.A.</i>	26
<i>Ostashkina E.E.</i>	68	<i>Ryabkov D.V.</i>	45, 64
<i>Ostrovsky D.Yu.</i>	133	<i>Ryazantsev G.B.</i>	73, 116, 139
<i>Ostrovsky Yu.V.</i>	133	<i>Rybakov A.</i>	148
<i>Outola I.</i>	134	<i>Ryuleeva V.S.</i>	118
<i>Panteleev V.N.</i>	104	<i>Ryzhkov M.V.</i>	30, 31
<i>de Paolo W.</i>	124	<i>Sabatino M.A.</i>	93
<i>Pavlyuk A.O.</i>	101	<i>Safonov A.V.</i>	50, 74, 83, 84, 146
<i>Pehrman R.</i>	121	<i>Safyanov G.A.</i>	116
<i>Peretrukhin V.</i>	84, 146	<i>Salbu B.</i>	140, 143
<i>Perfiliev Yu.D.</i>	171	<i>Sallinen J.</i>	106
<i>Peters D.</i>	98	<i>Sapozhnikov Yu.A.</i>	116, 124
<i>Petrov V.A.</i>	123	<i>Sardini P.</i>	121, 151
<i>Petrov V.G.</i>	22, 30, 31, 123, 162	<i>Sattelberger A.P.</i>	19, 25
<i>Petrova T.B.</i>	135	<i>Savchenko M.O.</i>	150
<i>Pichuzhkina E.M.</i>	23, 26	<i>Savelieva T.F.</i>	95, 102
<i>Plakhova T.V.</i>	24	<i>Savkin A.</i>	75
<i>Podymova T.V.</i>	54	<i>Savvatimova I.B.</i>	104
<i>Pohjolainen E.</i>	147	<i>Sazonov A.B.</i>	66
<i>Poineau F.</i>	19, 25, 84	<i>Sedova N.B.</i>	115
<i>Pokhitonov Yu.</i>	69	<i>Selishev V.A.</i>	169
<i>Polkanov M.A.</i>	46	<i>Semenishchev V.S.</i>	150, 177
<i>Polotskii Yu.S.</i>	20, 29	<i>Semenkov I.N.</i>	141
<i>Poluektov V.V.</i>	123	<i>Semenova A.A.</i>	107
<i>Poteri A.</i>	49	<i>Senik N.N.</i>	76
<i>Pribylova G.A.</i>	70	<i>Sergeecheva Ya.V.</i>	66
<i>Pryakhin E.A.</i>	124, 136, 145, 149	<i>Severin A.V.</i>	178
<i>Puchkova E.V.</i>	117, 137, 157	<i>Shabalin I.A.</i>	165
<i>Qiao J.</i>	176	<i>Shadrin A.</i>	77
<i>Radchenko V.M.</i>	7, 26	<i>Shapovalov V.V.</i>	158
<i>Radkevich A.V.</i>	34	<i>Shchepina N.E.</i>	28
<i>Rajander J.</i>	10	<i>Shestakov I.A.</i>	66
<i>Ramebäck H.</i>	33	<i>Shevchenko N.V.</i>	116
<i>Rasilainen T.M.</i>	138	<i>Shevchenko S.M.</i>	78
<i>Razzhivina I.A.</i>	27	<i>Sheveleva I.V.</i>	89, 173
<i>Read D.</i>	147	<i>Shi K.</i>	176
<i>Rego D.B.</i>	19	<i>Shipilova L.M.</i>	116
<i>Rigogliuso S.</i>	93	<i>Shirshin E.A.</i>	119, 161, 162
<i>Rissanen K.</i>	138	<i>Shiryayev A.A.</i>	142, 149, 161
		<i>Shishkin O.V.</i>	15
		<i>Shishkina S.V.</i>	15
		<i>Shmidt O.V.</i>	54

The First Russian-Nordic Symposium on Radiochemistry

<i>Shuh D.</i>	24	<i>Tyupina M.Yu.</i>	20, 29
<i>Sidorenko G.V.</i>	20, 29		
<i>Siitari-Kauppi M.</i>	49, 60, 121, 151	<i>Vaaramaa K.</i>	134
<i>Simon F.</i>	160	<i>Varlakova G.A.</i>	68
<i>Sinotova E.N.</i>	3	<i>Varnavin A.P.</i>	169
<i>Skålberg M.</i>	49	<i>Vasiliev A.N.</i>	103, 172
<i>Skipperud L.</i>	143	<i>Vatsuro A.M.</i>	172
<i>Skriplev M.I.</i>	43	<i>Veleshko A.N.</i>	17
<i>Skripnikov L.V.</i>	18, 21	<i>Veleshko I.E.</i>	17
<i>Skuridin V.S.</i>	100	<i>Veselov S.N.</i>	85
<i>Slastnikova T.A.</i>	105	<i>Veselova E.</i>	148
<i>Slesarev A.</i>	71	<i>Vesterbacka D.</i>	147
<i>Smirnov E.A.</i>	119	<i>Vesterbacka P.</i>	120
<i>Smirnov I.V.</i>	14, 15, 70	<i>Vinokurov S.E.</i>	48
<i>Sobolev A.S.</i>	105	<i>Virtanen S.</i>	35, 127
<i>Soboleva O.A.</i>	13, 27	<i>Vlasov Yu.G.</i>	163
<i>Sokolnitskaya T.A.</i>	173	<i>Vlasova I.E.</i>	6, 123, 124, 142, 149
<i>Solatie D.</i>	144, 147		
<i>Solin O.</i>	10, 96, 98, 106	<i>Volk V.I.</i>	77, 85
<i>Stefanovsky S.V.</i>	61, 79	<i>Volkov Yu.M.</i>	104
<i>Stegnar P.</i>	143	<i>Volkova S.V.</i>	113
<i>Stenhagen I.</i>	96	<i>Voloshin V.S.</i>	116
<i>Stepanov V.</i>	106	<i>Voronina A.V.</i>	150, 177
<i>Stepchenkov D.V.</i>	107	<i>Voutilainen M.</i>	49, 60, 121, 151
<i>Stepennov B.S.</i>	169		
<i>Suglobov D.N.</i>	20, 29	<i>Walther C.</i>	82
<i>Sukhoruchkin A.K.</i>	169	<i>Weck P.F.</i>	19
<i>Sulim E.V.</i>	107	<i>Wiikinkoski E.W.</i>	86
<i>Synytska A.</i>	160		
		<i>Yarusova S.B.</i>	165
<i>Talovskaya A.V.</i>	152	<i>Yaskolko A.A.</i>	104
<i>Telelekova A.D.</i>	115	<i>Yazikov E.G.</i>	152
<i>Teterin A.Yu.</i>	30, 31, 169	<i>Yegorov S.Yu.</i>	113
<i>Teterin Yu.A.</i>	30, 31, 169	<i>Yudintsev S.V.</i>	87
<i>Timonen J.</i>	49, 60, 151	<i>Yunusov M.</i>	143
<i>Titov A.V.</i>	18, 21, 32, 36		
<i>Tkachenko L.I.</i>	80	<i>Zabortsev G.M.</i>	133
<i>Tkachenko V.A.</i>	54	<i>Zaikin G.A.</i>	113
<i>Togaeva N.P.</i>	158	<i>Zaitsevskii A.V.</i>	9, 21, 32, 36
<i>Togneri L.</i>	81	<i>Zakharchenko E.A.</i>	88
<i>Tomilin S.V.</i>	6, 23, 26	<i>Zakharova E.V.</i>	50, 128
<i>Torapava N.</i>	33, 82	<i>Zalutsky M.R.</i>	105
<i>Torapava V.V.</i>	34	<i>Zarubo A.M.</i>	137
<i>Tour J.</i>	71	<i>Zhang L.Y.</i>	153
<i>Trapeznikov A.V.</i>	145	<i>Zheleznov V.V.</i>	89, 160, 165, 173
<i>Trapeznikova V.N.</i>	145	<i>Zhou W.J.</i>	153
<i>Tregubova V.E.</i>	50, 74, 83, 84, 146	<i>Zhuikov B.L.</i>	108
<i>Tretyakova S.G.</i>	54	<i>Zhuravlev F.A.</i>	109
<i>Troushin D.M.</i>	95, 102	<i>Zilberman B.Ya.</i>	45, 64
<i>Tryapitsyna G.A.</i>	136	<i>Zubekhina B.</i>	179
<i>Tuovinen H.</i>	147	<i>Zukau V.V.</i>	101, 110, 164
<i>Tyupina E.A.</i>	66		

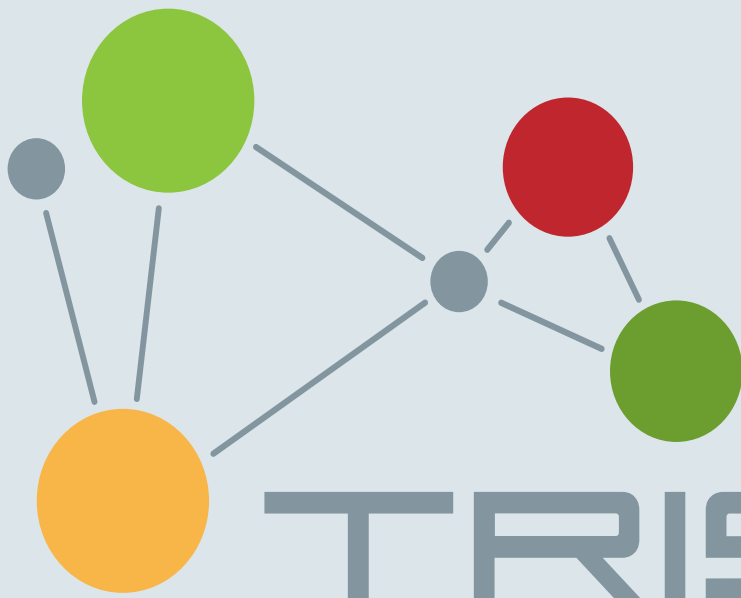

EXTRACTION CHROMATOGRAPHIC RESINS

TRISKEM

SEPARATION AND DETERMINATION OF RADIONUCLIDES

YOUR DOMAIN:

- Radiopharmacy
- Nuclear Fuel Cycle
- Environmental Monitoring
- Bioassay
- Radioactive Waste Monitoring
- Decommissioning
- Geochemistry

OUR RESINS:

HIGH SELECTIVITY
SIMPLE METHODS
RAPID&RELIABLE RESULTS



