

## Integration of Heat Pumps and Cogeneration in the Future Energy System

Ommen, Torben Schmidt

*Publication date:*  
2013

[Link back to DTU Orbit](#)

*Citation (APA):*

Ommen, T. S. (2013). Integration of Heat Pumps and Cogeneration in the Future Energy System [Sound/Visual production (digital)]. DTU International Energy Conference 2013, Lyngby, Denmark, 10/09/2013, [http://www.natlab.dtu.dk/Energikonferencer/DTU\\_International\\_Energy\\_Conference\\_2013](http://www.natlab.dtu.dk/Energikonferencer/DTU_International_Energy_Conference_2013)

## DTU Library

Technical Information Center of Denmark

---

### General rights

Copyright and moral rights for the publications made accessible in the public portal are retained by the authors and/or other copyright owners and it is a condition of accessing publications that users recognise and abide by the legal requirements associated with these rights.

- Users may download and print one copy of any publication from the public portal for the purpose of private study or research.
- You may not further distribute the material or use it for any profit-making activity or commercial gain
- You may freely distribute the URL identifying the publication in the public portal

If you believe that this document breaches copyright please contact us providing details, and we will remove access to the work immediately and investigate your claim.



# Introduction

- Political objectives for utility production are to reduce CO<sub>2</sub> emissions and increase security of supply.

Several solutions are proposed:

- ① High amount of intermittent electricity production from wind turbines and PV.
- ② Replacement of coal with biomass in thermal units.
- ③ Energy renovation in public and private buildings.
- ④ ...

# Introduction

- Political objectives for utility production are to reduce CO<sub>2</sub> emissions and increase security of supply.  
Several solutions are proposed:
  - ① High amount of intermittent electricity production from wind turbines and PV.
  - ② Replacement of coal with biomass in thermal units.
  - ③ Energy renovation in public and private buildings.
  - ④ ...
  
- Differently from “old” CO<sub>2</sub> reduction measures (“The Danish Example“):
  - ① The Production objectives for thermal power plants will be changed towards higher production of heat.
  - ② Combined Heat and Power (CHP) plants in DK are required to fulfill heat demand in timeperiods were electricity production is not favourable.
  - ③ New heat production facilities will be required : Biomass boilers, heat pumps, etc.

# Combined Heat and Power basics

- CHP-plants are the most efficient utility technology available today (in terms of exergy efficiency).
- High boiler efficiencies.
- High utilisation factor.
- Advanced flue gas cleaning.
- Easy flexibility between heat and power production, the trade off in an extraction power plant is typically 7-9 (can be compared to COP of a heat pump).
- Heat losses in DH network.
- Subject to boiler ramp rates.

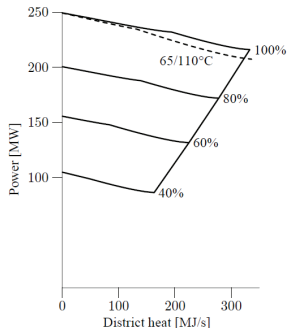

# Electricity and heat demand concurrency

- Coproduction allows higher efficiency and lower prices, but bad coherence between demand timeframe.
- Methods to decouple the prod. constraints of both heat and electricity may prove valuable.
  - electricity storage
  - heat storage
  - heat pumps
  - ...

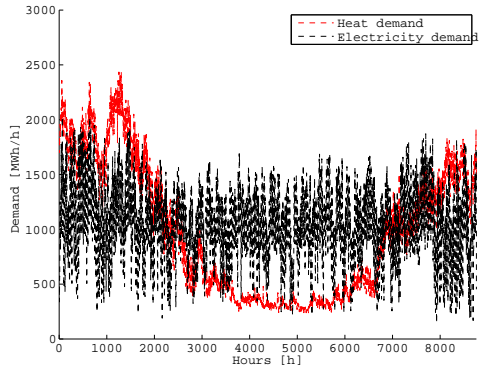

# Electricity and heat demand concurrency

- Coproduction allows higher efficiency and lower prices, but bad coherence between demand timeframe.
- Methods to decouple the prod. constraints of both heat and electricity may prove valuable.
  - electricity storage
  - heat storage
  - heat pumps
  - ...

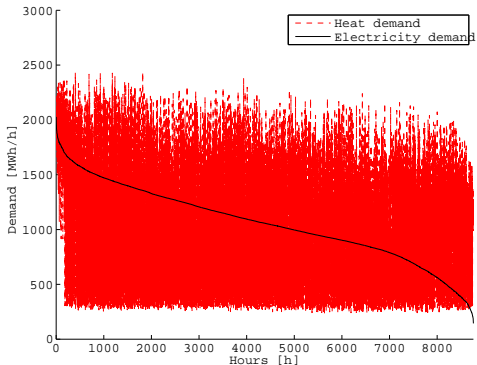

# Electricity and heat demand concurrency

- Coproduction allows higher efficiency and lower prices, but bad coherence between demand timeframe.
- Methods to decouple the prod. constraints of both heat and electricity may prove valuable.
  - electricity storage
  - heat storage
  - heat pumps
  - ...

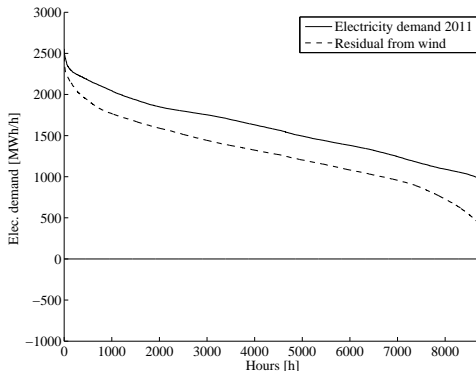



# Electricity and heat demand concurrency

- Coproduction allows higher efficiency and lower prices, but bad coherence between demand timeframe.
- Methods to decouple the prod. constraints of heat and electricity may prove valuable.
  - electricity storage
  - heat storage
  - heat pumps
  - ...

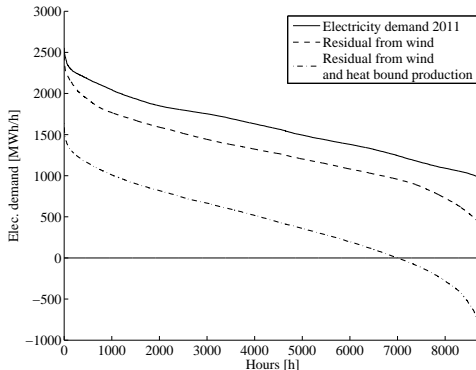

# Introduction of heat pumps in DH-systems

- The use of low cost electricity can expand the feasible production of heat in the PQ-diagram.
- Introduction of a Heat Pump with 50 MW capacity and a COP of 2,6 [-] at AVV1 results in a higher area of the feasible zones by 26,6%
  
- The changed operation of the system is the focus of further studies
- Preliminary study show that introduction of 100-300 MW Heat pump capacity in the Copenhagen Area allow an approx. 1-2 % fuel reduction of the power plants of Eastern Denmark.

# Introduction of heat pumps in DH-systems

- Five possible heat pump configurations have been identified for a system with DH networks

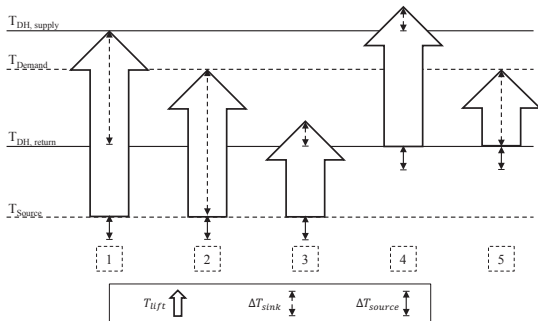

# Optimal heat pump design for configuration 1

- A thermoeconomic (exergoeconomic) comparison is conducted to evaluate the optimal heat pump design for the configuration and temperature of DH-network.
- 7 different working fluids are examined (R134a, R1234ze, R290, R407C, R600a, R717 and R744)
- The minimized cost of heat is calculated for each individual configuration and later compared in order to find the optimum.

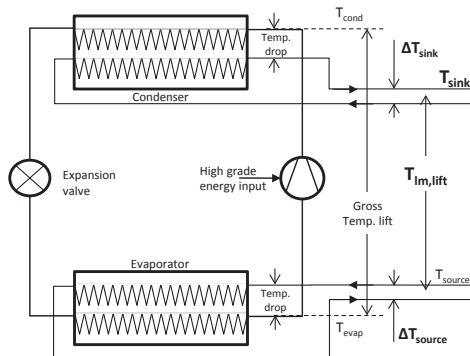

# Log mean temperatures

Heat reservoirs change temperature, i.e. log mean temperatures are required.

- Log mean temperature of sink

$$\bar{T}_{lm,sink} = \frac{(T_{h,o} - T_{h,i})}{(\ln(T_{h,o}) - \ln(T_{h,i}))}$$

- Log mean temperature of source

$$\bar{T}_{lm,source} = \frac{(T_{c,o} - T_{c,i})}{(\ln(T_{c,o}) - \ln(T_{c,i}))}$$

- COP Lorenz

$$COP_{Lorenz} = \frac{\bar{T}_{lm,sink}}{(\bar{T}_{lm,sink} - \bar{T}_{lm,source})}$$

- Lorenz efficiency

$$\eta_{Lorenz} = \frac{COP_{HP}}{COP_{Lorenz}}$$

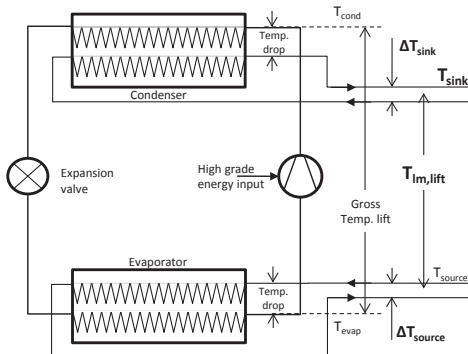

# Assumptions in heat pumps thermoeconomics

- Purchased Equipment Cost (PEC):
  - Open type compressor  $PEC = f(\text{working fluid; swept volume})$
  - Electrical motor with a fixed efficiency  $PEC = f(\text{shaft work})$
  - Heat exchanger  $PEC = f(\text{Area})$  [Yan et. al. 1998],[Yan et. al. 1999],[Martin 1996]
  - Expansion valve  $PEC = 0$
- Total Capital Investment of a component is 4.16 higher than PEC of the component to account for additional cost [Bejan et al. 1996].
- Electricity and natural gas prices correspond to the price of fuel (with variations) and taxes considering the heat pump operated by CHP-producer.
- Interest and Inflation Rate is fixed (7 % and 2.13 %)
- Technical lifetime of entire system: 15 years
- Operation Hours: 1400 hours/year

# The impact of the optimisation procedure

- In this example, the sink temperatures are fixed, and the source temperature is varied.
- R600a is investigated with four fixed pinch temperatures and compared to the optimal solution where the combined cost of the plant is minimised.
- In the optimal solution the evaporator and condenser can have different pinch temperatures.

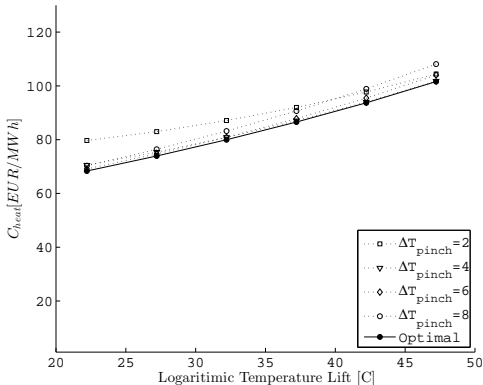

# Operation limits of current components

- Components are subject to mechanical and thermal stresses.
- The different component limits are identified for each working fluid.

Refrigerant	Cond. pressure $^{\circ}C$	Lubrication max. temp. $^{\circ}C$
R134a	82,8	170
R1234ze	96,1	170
R290	74,1	170
R407C	64,5	170
R600a	119,2	170
R717	90,79	170
R744	140 bar	170



# Minimised cost of heat - Comparison

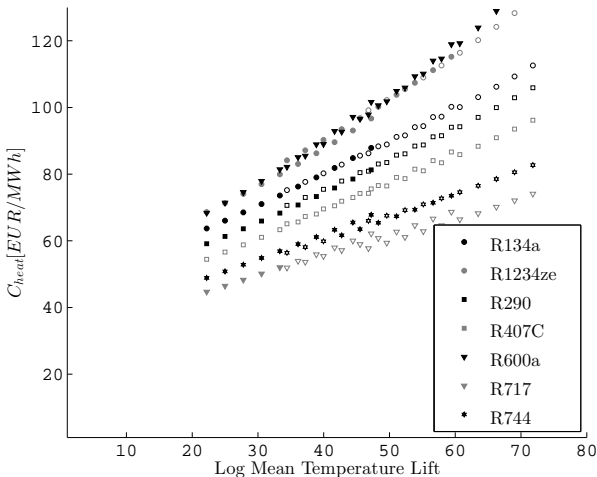

# Minimised cost of heat - Comparison

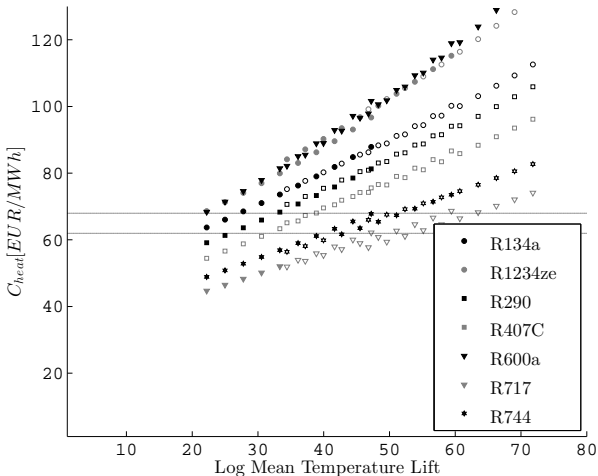

# Corresponding COP

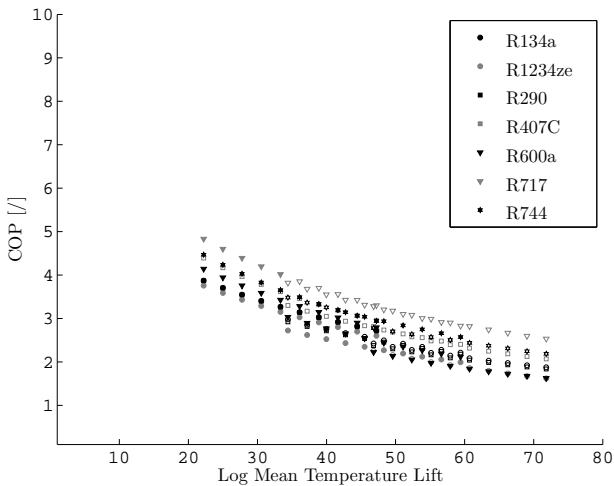

# Corresponding Lorenz efficiency

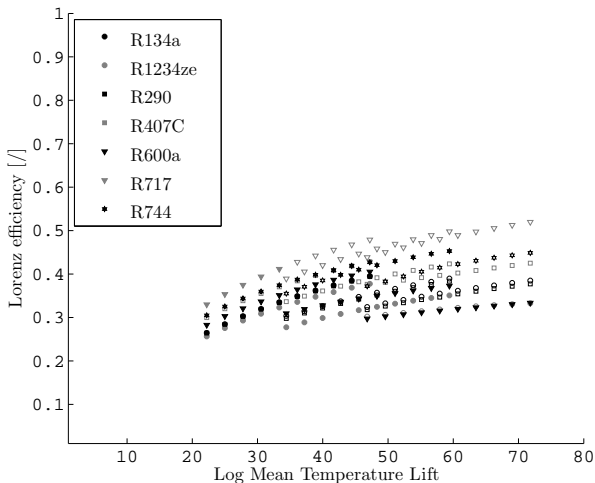

# Corresponding Lorenz efficiency

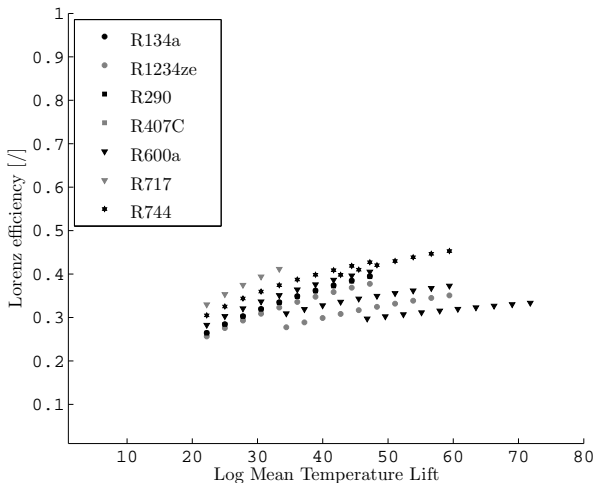

# Parametric study of assumptions and temperature levels

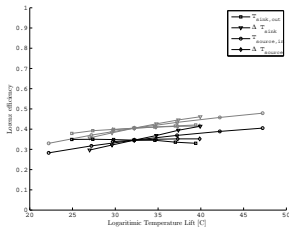
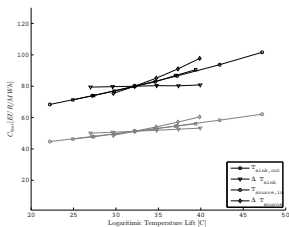
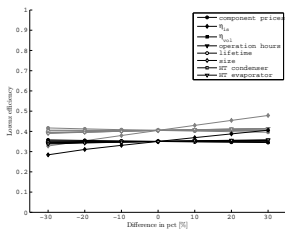
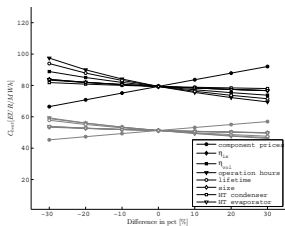

# Summary

- Efficient heat pumps can be used to decouple the constraints of electricity and heat production and address the high energy efficiency needed to match political targets.
- This presentation only includes configuration 1.
- For a fixed log mean temperature lift, the heat pumps can be ranked based on the cost of heat, where R717 has lowest cost.
- Most applicable heat pump solutions present higher cost than a natural gas boiler.
- $COP_{HP} < COP_{CHP}$
- Reasonable to expect a span of 1 between upper and lower performance on COP.
- Considering applicable equipment, a lower limit of 0.3 of Lorenz efficiency can be expected. In some cases 0.4 of Lorenz efficiency can be achieved.