



## Durham E-Theses

---

### *The Application of Superconducting Technologies in Future Electrical Power Systems*

ELSHERIF, MUSTAFA,ALI

#### How to cite:

---

ELSHERIF, MUSTAFA,ALI (2013) *The Application of Superconducting Technologies in Future Electrical Power Systems*, Durham theses, Durham University. Available at Durham E-Theses Online:  
<http://etheses.dur.ac.uk/9394/>

#### Use policy

---

The full-text may be used and/or reproduced, and given to third parties in any format or medium, without prior permission or charge, for personal research or study, educational, or not-for-profit purposes provided that:

- a full bibliographic reference is made to the original source
- a [link](#) is made to the metadata record in Durham E-Theses
- the full-text is not changed in any way

The full-text must not be sold in any format or medium without the formal permission of the copyright holders.

Please consult the [full Durham E-Theses policy](#) for further details.

---

Academic Support Office, Durham University, University Office, Old Elvet, Durham DH1 3HP  
e-mail: [e-theses.admin@dur.ac.uk](mailto:e-theses.admin@dur.ac.uk) Tel: +44 0191 334 6107  
<http://etheses.dur.ac.uk>

# The Application of Superconducting Technologies in Future Electrical Power Systems

Mustafa Ali Elsherif



School of Engineering and Computing Sciences  
Durham University

A thesis submitted in partial fulfilment of the requirements of the Council of the  
University of Durham for the Degree of Doctor of Philosophy (PhD)  
October 2013

## I. Abstract

Growing power demand in countries such as the UK can often result in increased power losses and voltage control problems within distribution networks. Mitigation of these issues in distribution networks is challenging when conventional power conductors and transformers are considered. There are several methods that may reduce losses in distribution networks, such as carefully sited and operated distributed generation (DG) and distributed control techniques. Since High Temperature Superconductor (HTS) cables exhibit zero resistance when cooled to the boiling point of liquid nitrogen (77Keliven), they have the potential to be used to address these issues in distribution networks. This thesis has investigated the impact of HTS cables and HTS transformers on power losses, voltage changes, fault levels and DG on an existing section of the UK distribution network and compares this with one utilising conventional cables and lines. This study has been accomplished using IPSA. Also, another piece of work calculates in terms of the power losses in HTS cables and HTS transformers including the power needs of their refrigeration systems. This has then been compared these to power losses incurred in conventional distribution and transmission networks.

Furthermore, the thesis introduces the comparison costs of HTS cables and HTS transformers with conventional cables and transformers and considers future projected costs for HTS cables and transformers. This information has been used to enable a techno economic evaluation of the potential of future alternative superconductor network design.

A method for reactive power sharing in an AC superconductor distribution network, including various DGs, has also been proposal. In addition, this thesis

has demonstrated the possibility of increasing the ability of electrical distribution networks to deliver high power densities to critical urban areas, whilst avoiding the need for heavy network reinforcement and additional assets. These studies are achieved using IPSA and Matlab software.

Finally, research of work was carried out to investigate the practical effects of installing superconductor equipment and identify novel network designs that make the best use of the attributes of superconducting network assets in terms of lower power losses, lower capital cost and a lower risk level than existing conventional distribution network designs.

In 2013, the total cost of the future 33kV superconductor distribution network design would be £842.1M higher than that of the present conventional distribution network design. However, by 2030 the future 33kV superconductor network design will be £16.86 M lower than the present conventional network design. Consequently, these results show that using HTS assets in large distribution network design, operating at different voltage levels could save millions of pounds in the future.

## **II. Declaration**

I hereby declare that this thesis is a record of work undertaken by myself, that it has not been the subject of any previous application for a degree, and that all sources of information have been duly acknowledged.

### **III. Acknowledgements**

I would like to express my deep and sincere gratitude to my supervisor, Professor Philip Taylor. It has been a great opportunity to work under his supervision; his wide knowledge, his patience and advice have been of great value for motivating me. Furthermore, his understanding, encouraging and personal guidance have guided me to accomplish this thesis. In addition, his comments were always constructive, important, supportive and at the right time throughout this work. I also warmly thank my co-supervisor, Professor Damian Hampshire for his encouragement and support, especially during writing for publications. Special thanks go to my family for their endless support and patience during my study.

The financial support of my country, through the Faculty of Engineering, Misurata University, is gratefully acknowledged.

Finally, I would like to thank my parents, my family, my relatives and my special friends, Sean Norris, Peter Wyllie and Paddy McNabb for their support and encouragement.

## IV. List of Publications

### Conference Proceedings

- Elsherif, M.A, Taylor, P.C. & Hampshire, D.P. (2011). Power Loss Evaluation of HVDC and DC HTS Transmission Solutions for Round 3 Offshore Wind Farms in the United Kingdom. *International Conference on Energy Systems and Technologies (ICEST)*, Cairo, Egypt.
- Elsherif, M.A, Taylor, P.C.(2011). Investigating the Impact of High Temperature Superconductor Cables on Electrical Distribution Networks. *International Conference on Energy Systems and Technologies (ICEST)*, Cairo, Egypt.
- Elsherif, M.A, Taylor, P.C. & Blake, S. (2013). Investigating the potential impact of superconducting distribution networks, *2013 CIRED* 0816 ,Stockholm, Sweden



# Table of Contents

|                                                                                                              |           |
|--------------------------------------------------------------------------------------------------------------|-----------|
| I. Abstract.....                                                                                             | i         |
| II. Declaration.....                                                                                         | iii       |
| III. Acknowledgements.....                                                                                   | iv        |
| IV. List of Publications.....                                                                                | v         |
| V. Nomenclature.....                                                                                         | xiii      |
| VI. Key to symbols in circuit drawings.....                                                                  | xvi       |
| <b>1. Introduction.....</b>                                                                                  | <b>1</b>  |
| 1.1. Statement of problem.....                                                                               | 1         |
| 1.2. Aims and Research objectives.....                                                                       | 3         |
| 1.3. Scope of Thesis.....                                                                                    | 4         |
| <b>2. Superconductivity.....</b>                                                                             | <b>8</b>  |
| 2.1. Theory of superconductivity.....                                                                        | 8         |
| 2.2. Superconductor state.....                                                                               | 11        |
| 2.3. Superconductor materials and projects.....                                                              | 12        |
| 2.3.1. Low Temperature Superconductor (LTS) materials.....                                                   | 13        |
| 2.3.2. LTS cable projects.....                                                                               | 15        |
| 2.3.3. High Temperature Superconductor (HTS) materials.....                                                  | 18        |
| 2.3.4. Design of HTS cables.....                                                                             | 19        |
| 2.3.5. HTS cable projects and developments projects.....                                                     | 21        |
| 2.3.6. HTS transformer projects and developments.....                                                        | 26        |
| 2.4. The price of HTS cables and transformers.....                                                           | 29        |
| 2.5. Applied HTS cables to urban environments.....                                                           | 31        |
| 2.6. Applied HTS cables to renewable energy sources.....                                                     | 33        |
| 2.7. DC superconductor power systems.....                                                                    | 35        |
| 2.8. AC Superconductor power systems.....                                                                    | 37        |
| 2.9. Summary.....                                                                                            | 43        |
| <b>3. Impact of HTS technologies on distribution and transmission power systems.....</b>                     | <b>44</b> |
| 3.1. Power losses in AC distribution networks.....                                                           | 45        |
| 3.2. Voltage control in distribution networks.....                                                           | 46        |
| 3.3. Description of the distribution network model.....                                                      | 50        |
| 3.4. Analysis of power losses in a conventional distribution network.....                                    | 51        |
| 3.4.1. Without distributed generators (DG).....                                                              | 52        |
| 3.4.2. With DG.....                                                                                          | 53        |
| 3.5. Voltage changes in conventional distribution network versus superconductor<br>distribution network..... | 53        |

|                                                                                                                                                           |           |
|-----------------------------------------------------------------------------------------------------------------------------------------------------------|-----------|
| 3.5.1. Without DG.....                                                                                                                                    | 54        |
| 3.6. Fault level (FL) studies .....                                                                                                                       | 55        |
| 3.7. The impact of HTS cables on the DC transmission networks .....                                                                                       | 59        |
| 3.8. The application of HVDC transmission technologies in the UK Round 3 offshore wind farms .....                                                        | 61        |
| 3.8.1. Voltage source converter based on HVDC .....                                                                                                       | 62        |
| 3.9. Using DC HTS cable for the UK Round 3 Offshore wind Farms .....                                                                                      | 65        |
| 3.9.1. Reduced power losses and increased power transfer capability .....                                                                                 | 65        |
| 3.9.2. The cost of off/onshore substations and transmission systems .....                                                                                 | 66        |
| 3.9.3. Voltage stability for transmission systems.....                                                                                                    | 66        |
| 3.10. The challenges of using DC HTS Technology for UK Round 3 offshore wind farms. ....                                                                  | 67        |
| 3.10.1. Cryogenics systems.....                                                                                                                           | 67        |
| 3.10.2. A high fault current in DC HTS cables.....                                                                                                        | 67        |
| 3.10.3. HTS materials are brittle .....                                                                                                                   | 67        |
| 3.11. A Comparison of the power loss of VSC HVDC and VSC HTS transmission systems used as transportation systems for UK Round 3 offshore wind farms ..... | 68        |
| 3.12. VSC HVDC and VSC DC HTS models .....                                                                                                                | 70        |
| 3.12.1. VSC based on HVDC IPSA model.....                                                                                                                 | 70        |
| 3.12.2. VSC based on DC HTS IPSA model.....                                                                                                               | 71        |
| 3.12.3. Evaluation of the power losses of VSC HVDC and VSC DC HTS IPSA models .....                                                                       | 73        |
| 3.13. The comparative cost HVDC and DC superconductor transmission systems .....                                                                          | 74        |
| 3.14. Summary .....                                                                                                                                       | 75        |
| <b>4. Reactive Power Sharing in Superconducting Power Systems.....</b>                                                                                    | <b>77</b> |
| 4.1. Sharing in conventional distribution networks .....                                                                                                  | 79        |
| 4.2. Types of control system for distribution networks to share reactive power between distributed generators.....                                        | 83        |
| 4.3. Case study .....                                                                                                                                     | 83        |
| 4.4. Controller requirement for sharing reactive power between two generators .....                                                                       | 85        |
| 4.5. Generator AVR model .....                                                                                                                            | 85        |
| 4.6. Modelling of the on load-tap changer transformer control systems.....                                                                                | 86        |
| 4.7. Objectives of the power management systems (PMS).....                                                                                                | 88        |
| 4.8. Control strategy.....                                                                                                                                | 89        |
| 4.9. Modelling an 11 kV superconductor distribution network .....                                                                                         | 91        |
| 4.9.1. 11kV HTS cables .....                                                                                                                              | 91        |
| 4.9.2. Calculation of the impedance of MV HTS cable .....                                                                                                 | 92        |

|                                                                                                                               |            |
|-------------------------------------------------------------------------------------------------------------------------------|------------|
| 4.9.3. HTS transformer .....                                                                                                  | 93         |
| 4.10. Testing the performance of the PMS controller .....                                                                     | 93         |
| 4.11. Results of simulation without PMS controller .....                                                                      | 95         |
| 4.12. Results of the simulation with PMS controller .....                                                                     | 99         |
| 4.13. Analysis of amplitude and duration of oscillation in superconductor and<br>conventional networks .....                  | 103        |
| 4.14. Power loss evaluation in superconductor and conventional distribution networks<br>.....                                 | 105        |
| 4.15. Comparison of energy losses and cost of energy losses in superconductor and<br>conventional distribution networks ..... | 106        |
| 4.16. Summary .....                                                                                                           | 108        |
| <b>5. Investigating the potential impact of superconductors in alternative distribution<br/>network designs .....</b>         | <b>110</b> |
| 5.1. Case Study Network .....                                                                                                 | 112        |
| 5.2. Analysis of voltage change in 20 kV conventional and superconductor distribution<br>network .....                        | 114        |
| 5.2.1. Peak demand .....                                                                                                      | 114        |
| 5.2.2. Future demand .....                                                                                                    | 115        |
| 5.2.3. Future onshore wind farm integration at minimum demand .....                                                           | 119        |
| 5.3. Capital cost comparisons of case study network .....                                                                     | 122        |
| 5.4. Reduce the capital cost for future superconductor distribution networks .....                                            | 124        |
| 5.4.1. Case study Network .....                                                                                               | 126        |
| 5.4.2. Modelling a superconductor distribution network .....                                                                  | 128        |
| 5.5. Investigation strategy .....                                                                                             | 128        |
| 5.6. Total power losses comparisons .....                                                                                     | 131        |
| 5.6.1. Results Discussing .....                                                                                               | 133        |
| 5.7. New possible designs of superconductor networks .....                                                                    | 134        |
| 5.7.1. Capital cost comparisons .....                                                                                         | 138        |
| 5.8. Summary .....                                                                                                            | 142        |
| <b>6. Reduction of the risk level in future superconductor distribution networks .....</b>                                    | <b>143</b> |
| 6.1. Conventional case study network .....                                                                                    | 144        |
| 6.2. Conventional distribution network - risk assessments .....                                                               | 146        |
| 6.2.1. Failure rates assumptions .....                                                                                        | 146        |
| 6.3. Calculation methodology of the Conventional distribution network .....                                                   | 147        |
| 6.3.1. Add failure rates to each zone .....                                                                                   | 147        |
| 6.3.2. Estimated proportion of failures .....                                                                                 | 148        |
| 6.3.3. Calculating the probability of power failure for customers .....                                                       | 149        |

|                                                                                            |            |
|--------------------------------------------------------------------------------------------|------------|
| 6.3.4. Calculation of the repair cost (RC) .....                                           | 150        |
| 6.3.5. Calculation of the customer interruptions (CI) costs .....                          | 151        |
| 6.3.6. Calculation of restoration time (RT) and the customer minutes lost (CML) costs..... | 151        |
| 6.3.7. Calculation of total network risk (TNR) .....                                       | 151        |
| 6.4. Superconductor case study network.....                                                | 151        |
| 6.5. Superconductor distribution network - risk assessments .....                          | 153        |
| 6.5.1. Failure rates assumptions .....                                                     | 153        |
| 6.6. Calculation methodology of the 33 kV superconductor distribution network .....        | 154        |
| 6.6.1. Add failure rates to each zone.....                                                 | 154        |
| 6.6.2. Estimate of proportion of failures .....                                            | 155        |
| 6.6.3. Calculating the probability of power failure for customers .....                    | 156        |
| 6.6.4. Calculation of RC.....                                                              | 156        |
| 6.6.5. Calculation of CI cost .....                                                        | 157        |
| 6.6.6. Calculation of RT and CML costs .....                                               | 157        |
| 6.6.7. Calculation of TNR.....                                                             | 157        |
| 6.7. New 33kV design for a superconductor distribution network .....                       | 158        |
| 6.7.1. Fault A .....                                                                       | 159        |
| 6.7.2. Fault B.....                                                                        | 160        |
| 6.7.3. Fault C or D .....                                                                  | 162        |
| 6.8. New 33 kV design of superconductor network - risk assessments .....                   | 164        |
| 6.8.1. Calculation of event probability of customers losing power.....                     | 164        |
| 6.8.2. Calculate RC cost.....                                                              | 164        |
| 6.8.3. Calculation of CI cost .....                                                        | 164        |
| 6.8.4. Calculation of RT and CML costs .....                                               | 164        |
| 6.8.5. Calculation of TNR.....                                                             | 165        |
| 6.9. Capital cost comparisons .....                                                        | 165        |
| 6.10. Summary .....                                                                        | 166        |
| <b>7. Conclusions and future work.....</b>                                                 | <b>168</b> |
| <b>References.....</b>                                                                     | <b>174</b> |
| <b>Appendix1.....</b>                                                                      | <b>190</b> |
| <b>Appendix2.....</b>                                                                      | <b>192</b> |
| <b>Appendix3.....</b>                                                                      | <b>193</b> |

## List of figures

|                                                                                                                                                                                                                 |     |
|-----------------------------------------------------------------------------------------------------------------------------------------------------------------------------------------------------------------|-----|
| Figure 1: The non-superconductor and superconductor state .....                                                                                                                                                 | 8   |
| Figure 2: The zero resistance in boiling temperature of helium liquid .....                                                                                                                                     | 9   |
| Figure 3: The relation between $T_c$ , $J_c$ and $H_c$ .....                                                                                                                                                    | 11  |
| Figure 4: The magnetic flux completely expelled from is interior superconductor .....                                                                                                                           | 14  |
| Figure 5: The differences between magnetic fields of superconductors I and II .....                                                                                                                             | 15  |
| Figure 6: The Cold dielectric design .....                                                                                                                                                                      | 20  |
| Figure 7: The Warm dielectric design .....                                                                                                                                                                      | 20  |
| Figure 8: A simple transmission link .....                                                                                                                                                                      | 47  |
| Figure 9: Phasor diagram for transmission for power through a serial impedance.....                                                                                                                             | 47  |
| Figure 10: The IPSA model for LV <sub>6.6kV</sub> distribution network with composite loads .....                                                                                                               | 51  |
| Figure 11: Voltage change in the superconductor distribution network. ....                                                                                                                                      | 55  |
| Figure 12: Voltage change in conventional distribution network. ....                                                                                                                                            | 55  |
| Figure 13: VSC based of HVDC transmission systems.....                                                                                                                                                          | 63  |
| Figure 14: The UK Round 3 Dogger Bank wind offshore farms in the United Kingdom                                                                                                                                 | 69  |
| Figure 15: IPSA model HVDC transmission systems for H3 offshore wind farm. ....                                                                                                                                 | 71  |
| Figure 16: IPSA model of DC superconductor transmission systems for the H3 offshore<br>wind farm. ....                                                                                                          | 73  |
| Figure 17: The real power losses in the DC superconductor transmission systems versus<br>the real power losses in DC HVDC transmission system. ....                                                             | 74  |
| Figure 18: Example of voltage changes in conventional and superconductor distribution<br>networks.....                                                                                                          | 82  |
| Figure 19: Configuration of the case study system.....                                                                                                                                                          | 84  |
| Figure 20: The generator AVR model, IEEE type.....                                                                                                                                                              | 86  |
| Figure 21: On-Load Tap-Changing Transformer model.....                                                                                                                                                          | 87  |
| Figure 22: The reactive power output control of 11kV generators .....                                                                                                                                           | 89  |
| Figure 23: The control system for OLTC of transformer .....                                                                                                                                                     | 90  |
| Figure 24: AmpaCity Project – Three Phases 40 MVA, MV cable concept .....                                                                                                                                       | 92  |
| Figure 25: Variable loads in the case study distribution network .....                                                                                                                                          | 94  |
| Figure 26: Results of voltage changes without PMS controllers in Simulations a)<br>Conventional Distribution Network, b) superconductor distribution network ( $V_{ref}$ 0.94pu)<br>.....                       | 97  |
| Figure 27: Results of Q (MVAr) without PMS controllers from grid and DGs in<br>Simulations a) Conventional Distribution Network, b) superconductor distribution<br>network ( $V_{ref}$ 1.005 and 1.002 pu)..... | 99  |
| Figure 28 : Results of Q (MVAr) with PMS controllers from grid and DGs in<br>Simulations a) Conventional Distribution Network, b) superconductor distribution<br>network .....                                  | 100 |
| Figure 29: Results of P (MW) with PMS controllers from grid and DGs in Simulations a)<br>conventional distribution network. b) Superconductor distribution network .....                                        | 101 |
| Figure 30: Results of voltage changes with PMS controllers in Simulations a)<br>Conventional Distribution Network. b) Superconductor distribution network.....                                                  | 102 |
| Figure 31: The largest oscillation occurring in the conventional and superconductor<br>distribution networks .....                                                                                              | 105 |

|                                                                                                                                                                                             |     |
|---------------------------------------------------------------------------------------------------------------------------------------------------------------------------------------------|-----|
| Figure 32: The existing 20kV distribution network model.....                                                                                                                                | 113 |
| Figure 33: The conventional distribution network at future demand.....                                                                                                                      | 117 |
| Figure 34: The onshore wind farms connect with the case study network conventional distribution networks .....                                                                              | 120 |
| Figure 35: The IPSA model for generic distribution network with composite load .....                                                                                                        | 127 |
| Figure 36: The voltage levels in the generic distribution network with composite loads after implanted the design1 .....                                                                    | 129 |
| Figure 37: The voltage levels in the generic distribution network with composite loads after implanted the design2 .....                                                                    | 130 |
| Figure 38: Total power losses comparisons .....                                                                                                                                             | 132 |
| Figure 39: The simple 10kV superconductor distribution network with composite loads .....                                                                                                   | 135 |
| Figure 40: The simple 33kV superconductor distribution network with composite loads .....                                                                                                   | 136 |
| Figure 41: Total power losses comparisons for 10kV and 33kV superconductor network designs at peak demand .....                                                                             | 137 |
| Figure 42: The cost of energy losses comparisons.....                                                                                                                                       | 138 |
| Figure 43: The capital cost comparisons between new designs of superconductor networks and present conventional network when Bi-2223 wire and cooling system is £128.1/kAm and £620/m ..... | 139 |
| Figure 44: The capital cost comparisons between new designs of superconductor networks and present conventional network when Bi-2223 wire and cooling system is £12.8/kAm and £620/m .....  | 140 |
| Figure 45: The capital cost comparisons between new designs of superconductor networks and present conventional network when Bi-2223 wire and cooling system is £6.4/kAm and £620/m .....   | 140 |
| Figure 46: Present configuration of case study conventional network .....                                                                                                                   | 145 |
| Figure 47: 33kV superconductor network circuits.....                                                                                                                                        | 153 |
| Figure 48: The superconductor case network study.....                                                                                                                                       | 159 |
| Figure 49: Zone A fault.....                                                                                                                                                                | 160 |
| Figure 50: Zone B fault.....                                                                                                                                                                | 161 |
| Figure 51: Zone C or D fault.....                                                                                                                                                           | 162 |

## List of tables

|                                                                                                                                                 |     |
|-------------------------------------------------------------------------------------------------------------------------------------------------|-----|
| Table 1: The history of superconductivity. ....                                                                                                 | 12  |
| Table 2: Properties of Type I superconductors which are usually simple elements .....                                                           | 14  |
| Table 3: Properties of Type II superconductors which are usually compounds .....                                                                | 15  |
| Table 4: The disadvantages of HTS materials. ....                                                                                               | 19  |
| Table 5: The difference in impedances between CD design cables and other .....                                                                  | 21  |
| Table 6: The prices of HTS cables and refrigeration systems in the present and future... 30                                                     |     |
| Table 7: The prices of HTS transformers and refrigeration systems in the present and future.....                                                | 31  |
| Table 8: The Dogger Bank offshore wind farms .....                                                                                              | 70  |
| Table 9: Electrical characteristics of MV UGC HTS cable and MV UGC conventional cables .....                                                    | 83  |
| Table 10: Test Regime for the PMS Controller (% age share of reactive power supply). 95                                                         |     |
| Table 11: Variable loads in the case study distribution network .....                                                                           | 95  |
| Table 12: The voltage change in the 20 kV conventional distribution network at peak. 115                                                        |     |
| Table 13: The voltage change in the 20 kV distribution network contains HTS cables at peak demand. ....                                         | 115 |
| Table 14: The voltage change in 20 kV conventional distribution network when future demands are considered .....                                | 117 |
| Table 15: The voltage change in 20 kV superconductor distribution network at future demand.....                                                 | 119 |
| Table 16: The maximum power can be injected by future onshore wind with 20 kV conventional distribution network at minimum demand .....         | 120 |
| Table 17: The maximum power that can be injected by future onshore wind with 20 kV superconductor distribution network at minimum demand .....  | 121 |
| Table 18: All relevant 132kV, 33kV and 11kV circuits and transformers with all associated ancillary assets.....                                 | 146 |
| Table 19: Failure rates for conventional network circuits .....                                                                                 | 147 |
| Table 20: All relevant 33kV circuits and associated ancillaries of transformers in a 33 kV superconductor distribution network .....            | 152 |
| Table 21: Failure rates for superconductor network circuits .....                                                                               | 154 |
| Table 22: The power losses comparisons .....                                                                                                    | 163 |
| Table 23: The comparisons in total network risk and capital cost for the conventional and 33kV superconductor distribution network designs..... | 167 |
| Table 24: The benefits and disadvantages of using HTS assets with distribution power systems.....                                               | 171 |

## V. Nomenclature









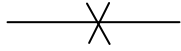

|            |                                                                            |
|------------|----------------------------------------------------------------------------|
| LTS        | Low temperature superconductor.                                            |
| HTS        | High temperature superconductor.                                           |
| MV         | Medium voltage.                                                            |
| LV         | Low voltage.                                                               |
| EHV        | Extra high voltage.                                                        |
| K          | Kelvin.                                                                    |
| GDNs       | Generic distribution networks.                                             |
| RE         | Renewable energy.                                                          |
| $N_{br}$   | Number of branches.                                                        |
| $R_i$      | Resistance of branch ( $\Omega/m$ )                                        |
| $X_i, X_t$ | Reactance of branch ( $\Omega/m$ )                                         |
| $I_i$      | Magnitude of current flow in the branch (A)                                |
| $\Delta V$ | Voltage change in the system from sending end to receiving end busbars (V) |
| $V_s^*$    | Sending end voltage (V)                                                    |
| Q          | Reactive power (VAr)                                                       |
| P          | Real power (W)                                                             |
| $P_{loss}$ | Real power losses (W)                                                      |
| $Q_{loss}$ | Reactive power losses (VAr)                                                |
| FL         | Fault level (MVA)                                                          |
| $I_f$      | Fault current (A)                                                          |
| $V_r$      | Voltage at receiving busbar (V)                                            |
| HVAC       | High voltage AC                                                            |

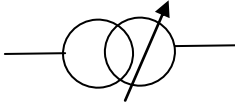

|                |                                                    |
|----------------|----------------------------------------------------|
| HVDC           | High –voltage DC                                   |
| $B_t$          | Susceptance of cable (SI)                          |
| $I_d$          | Discharge current (A)                              |
| $V_{dc}$       | DC voltage of the cable (V)                        |
| $Z_c$          | Surge impedance of the cable (SI)                  |
| $Z$            | Impedance of system ( $\Omega/m$ )                 |
| $L$            | Inductance of cable ( $\Omega/m$ )                 |
| $C$            | Capacitance of cable (f/m)                         |
| $I_t$          | Current through the transformer (A)                |
| $V_C$          | Magnitude of the resulting compensated voltage (V) |
| $V_{ref}$      | Reference voltage (V)                              |
| $(R_c + jX_c)$ | Compensator impedance ( $\Omega/m$ )               |
| PMS            | Power management systems                           |
| AVR            | Automatic voltage regulator                        |
| PI             | Proportional and Integral controller               |
| $\omega$       | Angular frequency of the network                   |
| $l$            | Length of the cable (m)                            |
| $r_s$          | Radius of the cable shield(mm)                     |
| $r_2$          | Outer radius of the cable phase(mm)                |
| OLTCT          | On-load tap change transformer                     |
| $P_S$          | Synchronizing power coefficient                    |
| $R_{sc}$       | Resistance of HTS cable ( $\Omega/m$ )             |
| $V$            | Voltage for infinite busbars (V)                   |

|                   |                                                                |
|-------------------|----------------------------------------------------------------|
| N                 | Number of wires                                                |
| A                 | Wire cross sectional area(mm <sup>2</sup> )                    |
| I*                | Complex current in the network (A)                             |
| CML               | Customer minutes lost                                          |
| RT                | Restoration time                                               |
| CI                | Customer interruptions                                         |
| TNR               | Total network risk(£)                                          |
| RC                | Repair cost (£)                                                |
| V <sub>t</sub>    | Measured phasor voltage at transformer secondary (V)           |
| μ <sub>0</sub>    | Magnetic constant                                              |
| ε <sub>0</sub>    | Electric constant                                              |
| ε <sub>r</sub>    | Relative permittivity of the dielectric                        |
| ρ <sub>wire</sub> | Wire resistivity (Ω·m)                                         |
| E'                | Generator constant voltage (V)                                 |
| δ                 | Power angle curve                                              |
| Z                 | Serial impedance between generator and infinitive busbar (Ω/m) |
| S                 | Complex power (VA)                                             |
| HP                | Heat pump                                                      |
| EV                | Electrical vehicle                                             |

## VI. Key to symbols in circuit drawings

| Name                   | Abbreviation of simple<br>in circuit drawings | Circuit drawing                                                                       |
|------------------------|-----------------------------------------------|---------------------------------------------------------------------------------------|
| Circuit Breaker        | CB                                            |    |
| Busbar                 | B                                             |    |
| Load                   | L                                             |    |
| Normally Open Point    | NOP                                           |    |
| Transformer            | T                                             |    |
| Voltage regulator      | VR                                            |    |
| Capacitor bank         | Cb                                            |   |
| Distributed generation | DG                                            |  |
| Cable or lines         | UG or OHL                                     |  |
| Measurement line       | ML                                            |  |

## 1. Introduction

### 1.1. Statement of problem

The transmission of a large amount of power from future renewable energy plants, such as offshore wind farms over long distances (hundreds of km), is accompanied by power losses caused predominantly by  $I^2R$  heating effects. In developed countries such as the UK, approximately 10% of generated power is lost in the transmission and distribution network before it reaches the consumer [1]. Ideally, power losses in the conventional transmission and distribution network should be around 3 to 6% of the total power delivered [1]. Utility companies are currently interested in reducing the power losses which are associated with transmission and distribution networks.

According to International Energy Outlook in 2008, worldwide energy demand will increase by 36.8% by 2030 [2]. The power demand in developed countries, especially in large cities such as London, will be increased, not only because of population growth but also because of urbanisation, new requirements such as electric vehicles and improvement in living standards. Annual growth in power demand in the UK is expected to average 2.3% over the period 2011 to 2026 inclusive [3]. Continued growth in the demand for power in densely populated urban areas where distribution networks exist raises questions about how to deliver more power, reduce power losses and reduce voltage drop in these critical areas. Consequently, there is increased interest in the integration of more distributed generators (DGs) into distribution networks to meet anticipated future demand [4]. Advantages of integrating these DGs into distribution

networks include enhanced power support, reduced power losses and improved voltage profile [5],[6], However, operating many of DGs into these networks increases issues associated with stability, power management and voltage regulation[7]. There are many techniques currently implemented in distribution networks to reduce the voltage excursions and power losses such as control sharing of reactive power between DGs, power factor control, capacitor placement and transformer tap changer control [8]. However, these techniques often increase system capital and operational costs.

Higher voltage levels require more physical space which is often at a premium in urban areas. Therefore the need of transmitting a high amount power at lower voltage levels is necessary in areas where space is very limited. In addition, increased delivery of power to urban areas is challenging when considering conventional power system technologies such as conductors and transformers, especially in cases where space to install new cables and transformers is scarce.

Transmitting power at different voltage levels in conventional distribution networks influences the amount of current that flows through the network's component cables, overhead lines and transformers. By delivering power at a higher voltage level, the amount of current transmitted through the distribution network is decreased; therefore the power losses are decreased. Transmitting power at higher voltage levels increases the cost of substations. Lowering the voltage has the opposite effect on power losses and costs [9],[10]. Consequently, many studies have attempted to introduce a new design for conventional distribution networks that target a reduction

in substation costs by reducing some voltage levels in networks [9],[10],[11]. This will be difficult to achieve in distribution networks with conventional equipment being used at lower voltage levels, because the resulting higher current will lead to higher power losses. A key challenge for conventional distribution network designs is to discover new and superior materials that can be used to improve the performance distribution equipment. This could include cables and transformers with significantly lower impedance and higher power ratings to reduce power losses and substations costs in transmission and distribution systems.

## **1.2. Aims and Research objectives**

Since High Temperature Superconductor (HTS) materials have zero resistance when cooled to the boiling point of liquid nitrogen (77K), interest in using HTS materials for power transmission is growing rapidly [12],[13]. The aim of the research described in this thesis is to investigate the potential benefits and challenges arising from the integration of HTS technologies into transmission and distribution power networks to address the previously highlighted issues that affect conventional transmission and distribution networks. This aim will be achieved by identifying and addressing seven broad areas where there is potential for improvement academic and industrial knowledge.

1. Reducing the power losses ( $I^2R$ ) which are incurred in transmission and distribution networks.
2. Overcoming voltage drop issues in urban areas combined with reducing the cost of installation requirements in distribution networks to maintain voltage within the required limits.

3. Increase the ability of electrical distribution networks to deliver high power densities into critical urban areas whilst avoiding the need for heavy network reinforcement and additional assets.
4. Propose a method for reactive power sharing in AC superconducting power systems.
5. Compare costs of HTS cables and HTS transformers with conventional cables and transformers and consider future projected costs for HTS cables and transformers. This information will then be used to enable a techno economic evaluation of the potential of future alternative superconductor network designs.
6. Introduce new topological designs of future superconducting distribution networks in the pursuit of lower capital costs and lower power losses in comparison to conventional networks.
7. Evaluate the comparative risks to customer supplies between conventional and superconducting distribution networks, and propose alternative and hybrid designs of superconducting distribution networks to manage any increase in risk.

### **1.3. Scope of Thesis**

Chapter 2 consists of two parts; materials and real examples of superconducting cable installation and a literature review examining the application of superconductivity into power systems. Part 1 reviews the theory of superconductivity and discusses the application of LTS and HTS materials to power networks. Current costs and projected prices of HTS cables and transformers are explained briefly, with respect to the possibility of applying superconductor systems to urban areas and renewable energy

systems. Finally, part 2 reviews superconductor power systems discussing both previous on DC and AC superconductor power systems and describing the materials and methods used.

Chapter 3 focuses on the impact of HTS cables and HTS transformers on AC electrical distribution networks. The chapter also describes research carried out to investigate the impacts of AC superconducting power transmission on real and reactive power losses, voltage fluctuations and fault levels for an existing UK low voltage distribution network when Cold-Dielectric (CD) AC HTS cables are considered. Existing conventional power systems and those containing AC superconducting cable are compared and conclusions drawn regarding the likely impact of superconducting cables on the design and operation of future power systems are drawn.

Chapter 3 also covers the impact of HTS cables on DC electrical transmission networks. This chapter describes research carried out to investigate the impact of DC superconducting power transmission on the real power losses, and fault levels for future offshore wind farms (Dogger Bank) which could be operational in the UK by 2020[14]. Furthermore, the potential for using conventional high-voltage transmission technologies, HVAC and HVDC with Round 3 offshore wind farms in the UK is introduced in this chapter. A comparison between HVDC and HVAC technologies highlights the challenges and requirements associated with the uptake of technologies for UK Round 3 offshore farms. In addition, a comparison will be made between voltage source converters (VSC) based DC superconductors and VSC based HVDC transmission technologies in delivering 1.2375GW (from



165,7.5MW Clipper Wind Britannia turbines) from Dogger Bank H3 offshore wind farm over a distance of 273km[15]. These comparisons focus on power losses and economic aspects. These investigations were carried out using two IPSA models, namely the 275kV HVDC and 100kV DC superconductor transmission power systems.

Chapter 4 addresses the possibility of sharing reactive power between distributed generators in MV conventional distribution networks and also in MV distribution networks containing HTS transformers and HTS cables. Also, power losses and the annual energy cost in conventional networks are compared with those of networks containing HTS transformers and HTS cables.

Chapter 5 investigates the impact of future REs, future demand including heat pumps (HPs) and electrical vehicles (EVs) on voltage profiles with existing UK MV conventional distribution networks. Moreover, the investigation introduces the impact of future demand including EVs, HPs and future REs on voltage profiles with existing UK MV conventional distribution networks which contain HTS cables and HTS transformers. Existing MV conventional power systems and those containing AC HTS cables and transformers are compared and conclusions drawn regarding the likely impact of HTS technologies on the capital cost and operation of future power systems.

Chapter 5 investigates the practical effects of installing HTS equipment and seeks to identify novel network designs which make best use of the attributes of superconducting network assets [6]. A case study was adopted

from generic distribution network models (GDNs). The network has been developed using IPSA software and real parameters for each component of the network. Two possible superconductor distribution network designs are described and compared in terms of power losses and capital cost. Finally, the comparisons of annual energy losses between a new superconductor distribution network and the present conventional network are also compared. The capital cost of these 2 superconductor network designs is calculated, based on current and also future cost of HTS cable and transformer materials. The superconductor network designs are evaluated based upon cost and also upon loss levels to find the best design and also the time taken to implement it.

Chapter 6 evaluates comparable risk studies between conventional and superconductor distribution network designs, and proposes a new design of superconductor distribution network. A case study will be adopted from GDN. The network has been developed using IPSA 2 software and real parameters for each component of the network. A proposal of a new design of superconductor distribution network was achieved, which results in lower power losses, lower risk level and reduced capital cost than the present conventional distribution network.

In the last chapter, conclusions are drawn from the thesis and steps are identified for further studies in the field.

## 2. Superconductivity

The first part of this chapter focuses on the theory of superconductivity and discusses the LTS and HTS materials. In addition, the most important projects in LTS and HTS cables and transformers are introduced. Furthermore, current prices of HTS cables and transformers, and projected prices are explained briefly, along with the possibility of applying superconductor systems to urban areas and renewable energy systems.

### 2.1. Theory of superconductivity

Before looking at the development of superconductor materials available today, it is useful to go back in time to their discovery. The electrical resistivity of several materials and alloys drop to zero when they are cooled to a low temperature (4K) as shown in figure 1. This phenomenon was discovered by Kamerlingh Onnes in 1911 when his experiments exhibited zero resistance in mercury metal cooled to the boiling point of liquid helium (4.2K) as shown in figure 2. In 1913, Kamerlingh Onnes won the Nobel Prize for his innovation [16],[17].

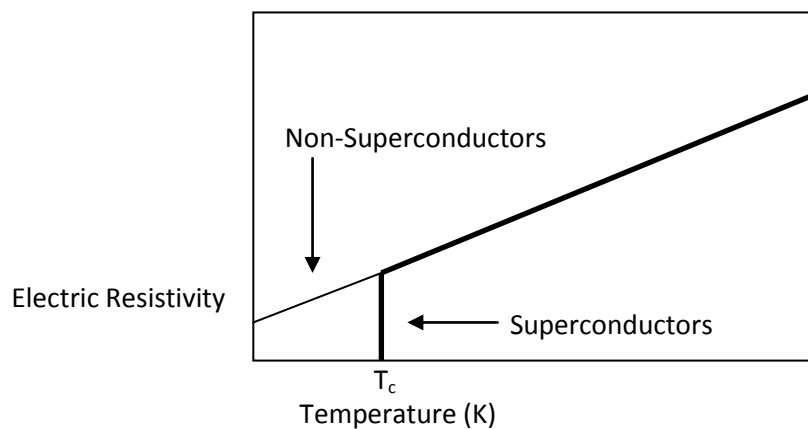

Figure 1: The non-superconductor and superconductor state

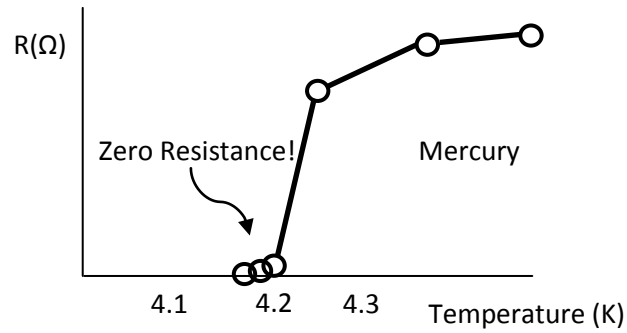

Figure 2: The zero resistance in boiling temperature of helium liquid

In 1933, when Robert Ochsenfeld and Walther were working in Berlin, they discovered the behaviour of magnetic fields in superconductivity [17]. They showed that when pure tin is cooled in the presence of a magnetic field, and then switched to superconductor tin, the magnetic flux in the tin will be suddenly completely expelled from the interior [16],[17]. Today, this discovery has become known as the Meissner Effect.

In 1950, a theory that explains the behaviour of superconductivity was developed by three American physicists: Leon Cooper, John Bardeen and John Schrieffer at the University of Illinois. It is known as BCS theory and explains how two electrons can be combined to form cooper pairs that are able to flow through a solid with no observable resistance [17]. Although the BCS theory explains the quantum mechanical phenomenon of superconductivity state, it does not introduce a clear insight into how to discover new superconducting materials or for the engineer searching for a practical way to use these materials for power applications [16].

In 1962, Brian Josephson was a graduate student at the University of Cambridge. He discovered the first commercial superconducting wire,

a niobium-titanium alloy, was developed by Westinghouse, allowing the construction of the first practical superconducting magnets

In the same year, Josephson found that electrical current can flow between two superconductor materials even when they are separated by insulating material [17]. This tunnelling occurs because the electron waves in metals do not cut off sharply at the surface, but drop to zero through a short distance outside [17]. This phenomenon is called the Josephson Effect. It was exploited using superconducting devices such as SQUIDs [18]. This device is used in the most accurate available measurements of the magnetic flux quantum. Coupled with the quantum Hall resistivity, this leads to a precise measurement of the Planck constant [18]. In the late 1960s, the superconductor materials were used to produce superconductor cables. These materials are called LTS materials [18]. Josephson was awarded the Nobel Prize for this work in 1973.

Then, in 1986, the temperature of superconductors was increased in new materials by K.A Müller and J.G. Bednorz. These materials are called HTS materials. K.A Müller and J.G. Bednorz from IBM researcher laboratory in Zurich, produced a brittle ceramic compound that exhibited superconductivity behaviour at temperatures higher than 30K [17]. In 2013, Massachusetts Institute of Technology (MIT) researchers introduced a new method for observing the motion of electron density waves in a superconducting material which led to the detection of two different kinds of variations in those waves: amplitude (or intensity) changes and phase changes, shifting the relative positions of peaks and troughs of intensity. These new findings could make it easier to search for new kinds of higher-

temperature superconductors of technology [19]. Table 1 shows the most exciting developments of superconductivity including the development of materials and applications [17],[18],[20].

## 2.2. Superconductor state

There are three important factors that define the superconductor state. These factors are: critical temperature ( $T_c$ ), critical current density ( $J_c$ ) and critical magnetic field ( $H_c$ ). To maintain material in superconductor state, these factors ( $T_c$ ,  $J_c$  and  $H_c$ ) must be under their critical values. Figure 3 shows the relation between  $T_c$ ,  $J_c$  and  $H_c$  [17].

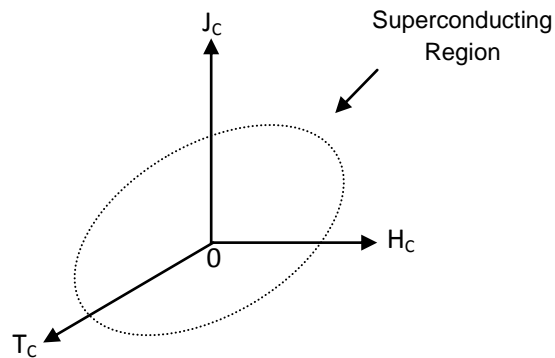

Figure 3: The relation between  $T_c$ ,  $J_c$  and  $H_c$

Table 1 : The history of superconductivity.

| Period    | Development steps and events                                                                                         |
|-----------|----------------------------------------------------------------------------------------------------------------------|
| 1911-1913 | Kamerlingh Onnes won the Nobel prize for his research (Properties of materials at low temperature)                   |
| 1957-1972 | Leon Cooper, John Bardeen and John Schrieffer won the Nobel prize for their research (BCS Theory)                    |
| 1960-1980 | Several Low-Temperature Superconductor cable projects were carried out for superconducting power transmission system |
| 1972-1973 | Brian Josephson won the Nobel prize for his research (Josephson Effect)                                              |
| 1980-1986 | Müller and J.G. Bednorz won the Nobel prize for their research (High-Temperature Superconductor Materials)           |
| 1991-1997 | Focus on materials – related research                                                                                |
| 1995-1996 | The first high current cable conductor models were constructed                                                       |
| 1997-1999 | Measurement techniques and working theoretical models describing AC losses                                           |
| 1997-1999 | Design and manufacture of first generation termination                                                               |
| 1997-1999 | Design and manufacture of the test and backup cooling subsystem                                                      |
| 1998      | A single 1 MVA HTS power transformer (13.8kV/6.9kV) was developed                                                    |
| 1999-2000 | Design and manufacture of the 30 m HTS cable system                                                                  |
| 2000      | Design and manufacture of the permanent cooling system                                                               |
| 2000      | Design of monitoring system of HTS cables include refrigeration systems                                              |
| 2001      | Testing and installation of complete system, first operation May 28 of HTS cables.                                   |
| 2001-2002 | Operation and evaluation in the electric grid for a period of 18 months until December 2002                          |

### 2.3. Superconductor materials and projects

The superconductor materials are divided into two types, LTS and HTS materials, independent of their properties. This section will discuss LTS and HTS materials and projects.

### 2.3.1. Low Temperature Superconductor (LTS) materials

This metal was the first LTS material, which may be divided into two types, type I and type II, dependent of their behaviour in a magnetic field. Both types, when at low temperature and below the magnetic field  $H_{c1}$ , the magnetic flux completely expels from its interior, as shown in figure 4. Type I superconductor materials have a single magnetic field  $H_{c1}$  [17]. The superconductor state on a type I only exists under this critical value of magnetic field, but above  $H_{c1}$  the material will switch to a normal state. Table 2 shows lists of the properties of type I superconductors. In all cases, which are shown in table 2, the critical magnetic field and critical temperature are less than 0.1T and 10 K [21].

In type II superconductors, which are usually compounds, the critical magnetic field is greater than the critical magnetic field of type I materials. They have two critical magnetic fields ( $H_{c1}$  and  $H_{c2}$ ). Up to a fairly low magnetic field ( $H_{c1}$ ), the magnetic flux is completely excluded in a similar way as in a type I superconductor. When above critical magnetic field, (the lower critical magnetic field ( $H_{c1}$ )), magnetic flux penetration occurs, although the bulk of the material still remains superconducting. When the value of a magnetic critical field is much higher than the upper critical field ( $H_{c2}$ ), all of the superconductor become II type normal materials, as shown in Figure 5 (B). Between  $H_{c1}$  and  $H_{c2}$ , the resistance is still zero and the superconductors remain in the same state. After  $H_{c2}$ , the superconductors change into a normal state. Table 3 shows a list of the properties of type II superconductors. In all cases shown in Table 3, the critical magnetic field and the critical temperature are greater than 0.1T and 10 Kelvin [17]



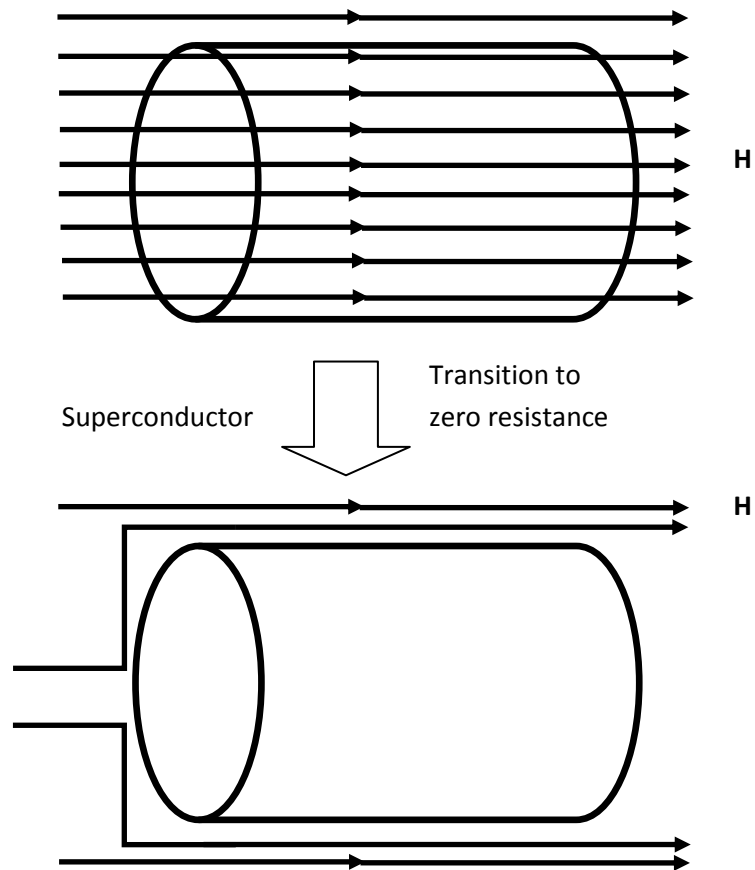

Figure 4: The magnetic flux completely expelled from its interior superconductor

Table 2: Properties of Type I superconductors which are usually simple elements[21].

| Materials | Critical temperature(K) | Critical fields(T) |
|-----------|-------------------------|--------------------|
| Aluminium | 1.2                     | 0.01               |
| Mercury   | 4.4                     | 0.04               |
| Lead      | 7.2                     | 0.08               |

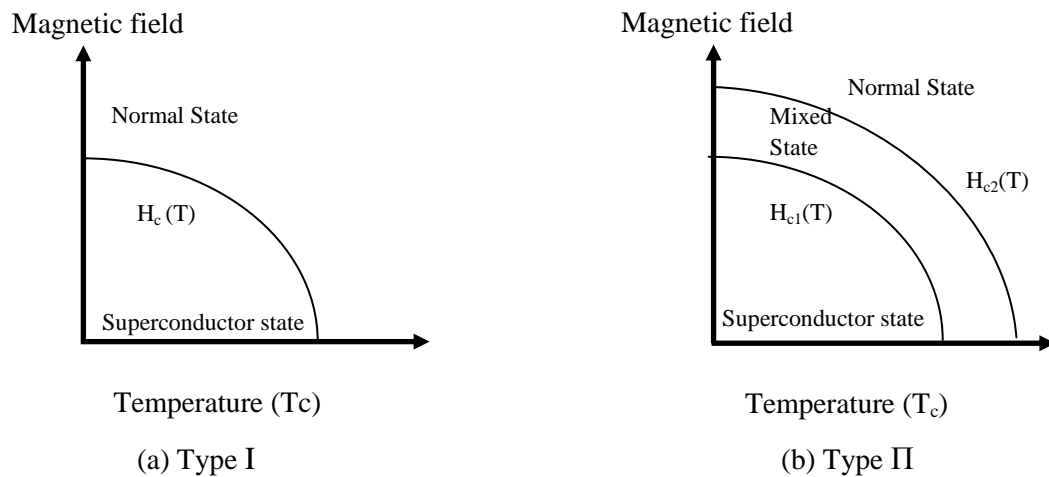

Figure 5: The differences between magnetic fields of superconductors I and II

Table 3 : Properties of Type II superconductors which are usually compounds[21].

| Material         | Critical temperature(K) | $H_{c1}$ at 4.2K | Maximum B in use | $J_c$ at 4.2K ( $\text{Amm}^{-2}$ ) |                  |
|------------------|-------------------------|------------------|------------------|-------------------------------------|------------------|
|                  |                         |                  |                  | H=4T                                | H=10T            |
| niobium titanium | 10.2                    | 12               | 8                | $15 \times 10^3$                    | $15 \times 10^3$ |
| Niobium-tin      | 18.3                    | 22               | 16               | $20 \times 10^3$                    | $2 \times 10^3$  |

### 2.3.2. LTS cable projects

From the late 1960s until the mid-1980s, several LTS cable projects have been implemented for superconducting power transmission system [18]. The LTS cable projects were mainly designed to deliver large amounts of power (1000 MVA or greater) over short distances (50 – 100m). These projects started in the US,

Europe, and the former Soviet Union and the most important LTS projects during this period are introduced in the following sections.

### **2.3.2.1. Institute for Low Temperature Physics, Austria**

In the mid-1970s Professor Klaudy of the Anstalt fur Tieftemperaturforschung in Graz, Austria, arranged for a single-phase superconducting cable to be built near the overhead transmission lines from a hydroelectric station at Amstein [22]. It was designed as a short length cable 50 m at 60kV (1000A) [21]. Switchgear was added so that one phase could be transmitted through 50 m of cable when it was sufficiently cold [23]. This project was operated successfully on grid in 1979 and 1980.

### **2.3.2.2. Los Alamos National Laboratory, US**

This LTS cable project was the first DC superconducting transmission cable. This cable exhibited several advantages compared to the 60kV LTS cable: DC LTS cable construction is simple, operates at slightly higher temperatures, there are no AC losses on DC LTS cable and DC LTS requires two conductors rather than three. DC LTS cable can deliver current at a much higher level than AC LTS cable for the same capital cost. However, the DC LTS cables are more expensive than AC LTS in short distances because the DC LTS cables need a converter at each end and this means extra cost is required for DC LTS cable. Therefore, AC LTS cables are feasible in short distances, but there is a limitation for longer distances, approximately less than 100km (after that reactive compensation will be required to install) for underground cables [24]. Several conductors were manufactured, but there were no cables that had been built when the project was cancelled in 1979 because of changes in priorities [18].

### **2.3.2.3. Brookhaven National Laboratory, US**

In 1980, the AC LTS cable project was in Brookhaven National Laboratory, US. The LTS cable was tested from 1982 to 1986, and the test length was the longest to be built up to that time [23]. LTS cable was used with the LTS material,  $Nb_3Sn$  tape, to produce a flexible design in a rigid tube. It also had a refrigeration system utilising helium liquid at 9K and it had electrical insulation of lapped polymeric tape penetrated by the refrigerant. The test site at Brookhaven National Laboratory presented all the equipment necessary for testing a three phase rating cable 135kV, 1000 MVA in a single phase mode. This project proved for the first time the ability of a superconducting transmission cable to deliver large amounts of power (1000 MVA) [18].

The major issue with implementing LTS cables for power transmission is the cost of operating, and maintenance at a low temperature (4K to 9K). The cost of the liquid helium refrigeration system made commercial transmission cables based on LTS wires impractical. On the other hand, LTS materials are not expensive, such as  $Nb_3Sn$ , but they have shown some disadvantages: they are brittle and require a very low operational temperature (4K to 9K). One LTS cable project had shown the ability to deliver power 1000 MVA, but once more, the cost of the refrigeration system was very expensive [18]. As a result, there are two areas of LTS cable technology requiring development. Firstly, reducing the cost of refrigeration systems; the cost of a litre of liquid helium, which was used as cryogen liquid for LTS cables, is approximately \$5 and this is very expensive. Secondary, maintaining the operational temperature of the LTS cable at a low temperature (4K - 9K)[18].

### 2.3.3. High Temperature Superconductor (HTS) materials

In 1986, HTS materials were discovered which could maintain zero resistance at much higher temperatures than LTS materials. However, the most exciting feature of these materials is their ability to transmit a high current density (200 times the electrical current of copper wire of similar dimensions) at the temperature that can be achieved with liquid nitrogen, 77K[12],[25]. The science and technology of superconductors have developed in recent years, and their development has accomplished an industrial level in terms of HTS materials. The compounds bismuth superconductor (BSCCO) and yttrium superconductor (YBCO) have obvious commercial potential and are the results of immense academic and industrial research efforts worldwide

HTS materials have two generations. The first generation is a bismuth superconductor (BSCCO) and the second generation is a yttrium superconductor (YBCO). In 1987, YBCO was discovered in the US. The critical temperature, which is 90K, is higher than the boiling point of liquid nitrogen (77K/-196C<sup>0</sup>). Liquid nitrogen is ideal to use as a refrigeration system for this material. In 1988, Bi<sub>2</sub>Sr<sub>2</sub>Ca<sub>2</sub>Cu<sub>3</sub>O<sub>10</sub> was discovered in Japan. It set a new record of T<sub>c</sub> = 110K, which is higher than the value for the previous material, YBCO (20K) [12]. There are some problems with HTS materials in terms of their transmission application, as shown in Table 4 [26],[27].

Table 4: The disadvantages of HTS materials.

| Problem                  | Explanation                                                               |
|--------------------------|---------------------------------------------------------------------------|
| BSCCO materials          | BSCCO materials are fabricated inside a silver matrix, which is expensive |
| BSCCO and YBCO materials | HTS materials are brittle, so it is hard to form them in long wire        |

HTS materials can operate at much higher temperatures than LTS materials. These operational temperatures are suitable for using liquid nitrogen (77K) as a refrigeration system. The cost of liquid nitrogen is much less than liquid helium. The cost of a gallon of liquid nitrogen is \$0.10, which is between 50 and 200 times cheaper than liquid helium [13]. It is useful to look at the cryogenic liquids which can be applied for HTS materials.

#### 2.3.4. Design of HTS cables

HTS cables have been developed for AC rather than DC applications. Basically, there are two classifications of HTS design cables: Warm Dielectric (WD) and Cold Dielectric cable (CD) [27]. Such a design has numerous advantages over conventional cables such as increasing power capacity and reducing power losses. The WD HTS cable can deliver more power (3-5 times) than a conventional conductor (copper cables) while the CD HTS cable can transmit power from 8 to 10 times more than a conventional model (9000A for HTS vs. 1000A copper cable) [27].

The CD HTS cables have been used for this work for many reasons: to reduce AC losses, for higher current capacity and for lower inductance. In addition, the

inductive impedance of CD HTS cables is up to six times lower than that of conventional cables and twenty times lower than overhead lines of the same voltage [28]. Figures 6 and 7 show the layout of warm dielectric and cold dielectric cables [29].

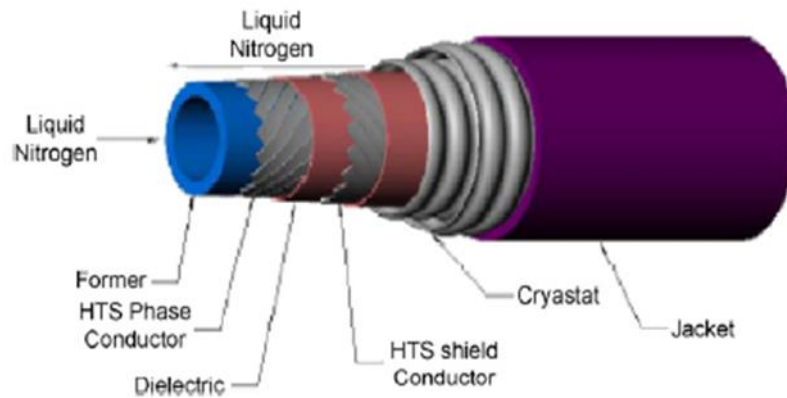

Figure 6: The Cold dielectric design [29]

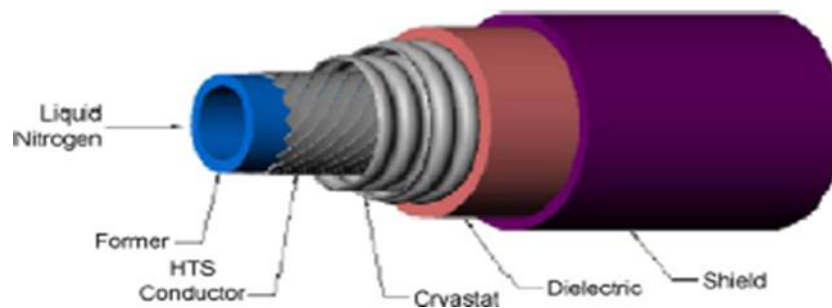

Figure 7: The Warm dielectric design [29]

Table 5 shows the difference in resistance, inductance and capacitance between CD design cables and conventional cables in power transmission technology [28], [30],[31].

Table 5: The difference in impedances between CD design cables and other

| A comparison of power transmission technology |                                      |                       |                        |
|-----------------------------------------------|--------------------------------------|-----------------------|------------------------|
| Technology                                    | Resistance<br>( $\Omega/\text{km}$ ) | Inductance<br>(mH/km) | Capacitance<br>(nF/km) |
| Cold dielectric HTS                           | < 0.0001                             | 0.06                  | 200                    |
| Conventional XLPE                             | 0.03                                 | 0.36                  | 257                    |
| Overhead line                                 | 0.08                                 | 1.26                  | 8.8                    |

### 2.3.5. HTS cable projects and developments projects

Many HTS cable projects have been implemented and connected to utility grids throughout the world. Some of these HTS cable projects in utility grids were in the US. Of the projects, the one in Detroit was unsuccessful because of technical problems in refrigeration system, but other projects have been technically successful [27],[28],[29]. Other HTS cables projects have been accomplished in countries such as China, South Korea, Japan and Germany. Some projects have been cancelled due to a lack of need, for example, no longer a need for an increased capacity to systems [30],[31],[32],[33],[34],[35]. It has been suggested that in all of these projects, HTS cables should be installed in urban areas due to the opportunity to meet the future power demand in urban areas as one aid to avoid congestion network issues. The most important of these projects are summarised as follows.

In Carrollton, GA, the first HTS cable was implemented which delivered power to live load[29]. This project was implemented by the Southwire Company. An HTS



three phase (CD) cable was installed above the ground with a system in order to test the performance of the HTS cable. In January 2000, the HTS cable system operated completely successfully over 40,000 hours at full load and proved that it had the ability to carry 1.25 kA at 12.47kV [29]. The length of the HTS cable was 30m.

A second HTS cable system was unsuccessfully installed in Detroit by the Pirelli Company in 1999 [28]. The project aimed to install the HTS cable underground at Frisbie substation, and it was the first project which attempted to install an HTS cable underground. The HTS cable was pulled through 20m diameter tunnels for 120m in an attempt to connect the two sides of the Frisbie substation [27]. It aimed to deliver 2400A at 24kV of line operation [27]. There were issues with the refrigeration systems for the HTS cable, so the operational testing could not be completed. The HTS cable proved that there was no damage occurring during the installation and the opportunity to install HTS cables underground, which would be ideal in urban areas.

There are three more HTS underground cables that have been installed in the US, and two projects in China and Japan. All of them were installed and operated in the utility grids of major electrical suppliers.

One HTS cable project was installed at Bixby substation in Columbus, OH,US. It was led by Southwire among other US companies. The HTS cable was designed to carry 3000A at a voltage rating of 13.2kV over 200m [36]. In 2006, the HTS cable system operated perfectly and served power to 36,000 homes [36]. The project continued into 2009 with the continued monitoring of the cable system and the installation of two 1kW pulse tube coolers. This project attempted to reduce

the cost of operating the system, to increase the length of the HTS cable and to successfully install an HTS cable underground without any interruptions or damage.

A second HTS cable project was carried out by the Sumitomo Company. The cable was installed in downtown Albany, US. The cable connected two substations in Albany and it was designed to deliver 800A at a voltage level of 34.5kV over a length of 350m [37]. The HTS cable was able to run for 100m between refrigeration systems. The HTS cable system began operating at 21:00 in 2006 and it was connected to the grid for 7000 hours without any interruptions [27]. The test results were completely successful and did not indicate any failures or damage. In addition, the HTS cable was tested in order to confirm its superconducting properties after installation with an applied direct current of up to 6,000A [37]. The results of the test indicated that no damage occurred to the HTS cable during operation or the installation process. The developments which were achieved by this project are as follows: it was the longest HTS cable system which had been applied at that time, and it tested two YBCO and BSCCO HTS cables in order to provide an opportunity for future commercialisation, and to improve the price and performance characteristics [38].

The third HTS project was carried out by Nexans Company in Long Island, US, in 2008. This HTS cable system was installed between two substations and designed to carry 2400A at a voltage rating of 138kV over a length of 620m. Since being implemented, the system has operated successfully [30]. When operating at full capacity, the HTS cable system can transmit up to 574MW of power, which is enough to power 300,000 homes [30]. This project achieved the longest

installation of an HTS cable in the world, at 620m. This is a significant improvement.

A project for 35kV /2kA HTS cables has been installed and operated into real grid in China since 2004. It has installed in Puji substation in Kunming, Yunnan, China to supply power to industrial customers and a resident population of around 100,000 [31].

In Yokohama, Japan, another HTS cable project was supported by the Ministry of Economy, Trade and Industry (METI) and New Energy and Industrial Technology Development Organization (NEDO). This project began in 2007 and It took five years to investigate the performance of HTS cable before applying to a live grid [32],[39]. The main aim of this project was to confirm the reliability and stability of HTS cable system (66kV/200MVA) in real grid[40].

Several HTS cable projects across the world are underway in order to apply HTS cables to real grids to solve issues which will be faced by conventional power systems, especially in urban areas. Additionally, these projects are mainly aimed to develop HTS cables in terms of reducing the cost of cables and increasing their length. One project is in New Orleans, US, and is run by the Southwire Company. The HTS cable system will connect two substations underground at 13.8kV. Southwire was planned to use a 13.8 kV HTS cable to connect two existing substation sites that are 1.1 miles apart which will solve a real-world electrical load problem near downtown New Orleans [41]. Moreover, the project was planned to operate in 2011 but the project has been since cancelled because there was no longer a need for increased more power to that load. This project proved that the HTS cable can be produced at longer length than 620m.

There is another ambitious project to increase the length of HTS cable to 6km [42]. Nkt cables and Praxair are working together to produce a 6km HTS cable to be applied to deliver power in the High Voltage grid in Amsterdam in 2014 [43]. This cable will be introduced as an opportunity to remove 150kV network by replacing 50 kV networks using 50 kV HTS cable which can transmit power up to 250MVA [44]. This project gives the potential to deliver high amounts of power at low voltage to reduce the insulation and installation cost requirement. This also give the opportunity to apply to future renewable energies [33],[44].

Another 10 kV HTS cable will be used in the “AmpaCity” project by Nexans in 2013 which will deliver power of up to 40 MVA between two substations in Essen, Germany, using a cable system of approximately 1km with one joint. The field test for the 10 HTS cable will last for at least two years [34]. This project will give the opportunity to replace 110kV network by 10 kV network using 10 kV HTS cable in terms of reducing cost of insulation and installation requirements in the network.

Another project is undertaking to develop 22.9 kV HTS cables in order to apply to real grid in china. The cable was tested to prove that it can transmit 1.25kA at 22.9kV with 100m length [35]. This project has been manufactured by Sumitomo Electric Industries in 2002 who started testing from 2006 to 2009. Tests showed that HTS cable was installed successfully and operated without any fault or damage at peak power capacity [35]. This project gave an opportunity to apply in urban areas in big cities in South Korea, such as Seoul, to meet future demand. Moreover, the cable can transmit bulk power with low voltage and low power losses; therefore, it introduces the possibility to re-configure grids to deliver power at low voltage by removing 154kV networks using 22.9kV HTS cables.

Furthermore, it is promising to overcome voltage drop issues which are associated with conventional cables and transformers in the future demands in South Korea [45]. This cable is planned to be connected to the real grid in 2013 in Korea [35].

These projects have aroused global interest in HTS cables. The main opportunity provided by HTS cables is as a result of their capability to transport a large amount of power to critical locations e.g. to an urban environment, in order to meet the increasing power demands. Furthermore, they have potential to a reconfiguration of the distribution network to deliver high power at low voltage and with lower power losses. This aids to reduce the capital cost of distribution networking by removing intermediate voltage levels of networks. The designers and engineers of these projects believe that one day they will be able to solve all the aforementioned issues, and then HTS cables will have a significant impact on the global power transmission system. The cost of HTS cables is expected to decrease due to wider market access.

### **2.3.6. HTS transformer projects and developments**

Development of HTS transformers has been achieved in many countries such as the US, Europe, China, Japan and Korea. The development of HTS power transformers over the world is summarised as follows.

The US development program – Superconductivity Partnership Initiative (SPI) project has a subproject of HTS power transformer project, with a purpose to establish HTS transformers of medium-to-large (>10MVA) ratings through three stages: 1 MVA to 5/10 MVA to 30/60 MVA. A single-phase 1 MVA (13.8kV/6.9kV) HTS power transformer using Bi-2212 coated conductor and a three-phase 5/10 MVA (24.9kV/4.2kV) HTS power transformer using Bi-2223

coated conductor has been developed in 1998 and in 2004, respectively [46]. In 1998, a single 1 MVA HTS power transformer (13.8kV/6.9kV) was developed. After that, the power rating of this three-phase HTS power transformer raised to 5/10 MVA (24.9kV/4.2kV) in 2004 . This project proved that Bi-2212 and Bi-2223 coated conductors can be applied successfully to develop 1-MVA and 5/10 MVA HTS transformers [47].

Another three-phase transformer has been innovated to operate at transmission level voltage 138kV and above. The major target of this project is to use YBCO HTS wires and to use more conventional transformer technologies to reduce capital costing of HTS transformers [46],[48].

In China, a three-phase 630kVA HTS power transformer was developed. This project was supported by the Chinese “863” programme and the Tebian Electric Company (TBEA) and started to develop a 630kVA HTS power transformer (10.5/0.4kV). Furthermore, three-phase 26KVA (400kV/16 V) HTS transformer and a single-phase 45kVA (2400V/160V) were first designed respectively in 2003 and 2004 [49]. Three-phase HTS power transformers were tested by China National Transformer Quality Supervision Testing Centre in 2005 [50]. Moreover, the ABB has tested a three-phase 630kVA by operating in live grid for one year at a successful reliable ability [50],[51].

In Korea, a single-phase HTS power transformer was developed and tested in 2004 [52],[49]. This project aimed to develop winding using the double pancake windings made of Bi-2223 HTS wires [51]. A single-phase 33MVA (154kV/22.9kV) and a single 60MVA (154kV/22.9kV) HTS power transformers were designed in 2006 with an on-load tap changer using YBCO and BSCCO

wires respectively in 2005 and 2006 [53],[54]. In 2007, a three-phase 100MVA (154kV/22.9kV) HTS transformer was designed by a Korean power company to supply future demand without new constructions of substations [55].

In Japan, a single-phase 2MVA (66kV/6.9kV) HTS power transformer was manufactured and tested in 2004 [49],[56]. This design aimed to contribute to the development of a 10MVA (66kV/6.9kV) HTS power transformer in 2005 [49],[56].

In Switzerland, a three-phase 630kVA (13.72kV/0.42kV) HTS power transformer was developed in 1997 by American Superconductor Corp. and it operated into power grid in 1997, successfully for one year [46],[49].

Some countries mainly concentrate on development traction HTS transformer in terms of reducing weight and size of traction. In Germany, a 10MVA HTS transformer was planned to reduce the size of transformers by 30-40% if the efficiency would increase from 94% to 99%. This was suggested by Siemens in 1996 [46].

Today, HTS tapes are available for use in the windings of transformers [57]. Applying HTS materials in transformers provides several benefits over conventional transformers, including higher power density, lower operating losses, fault current limiting, lower impedance, smaller weight, smaller size and better voltage regulation [48]. These projects claim that HTS transformers can be commonplace in the future and that they can overcome many issues which are associated with conventional transformers in terms of increasing efficiency transformers, reducing power losses and size, and increasing the power rating of transformers. Many engineers and designers are focussed on the development of

the design of HTS transformers in terms of reducing the capital cost of HTS transformers, and they believe that HTS transformers will be powerful enough to apply in urban areas to avoid additional costs and meet future demand.

#### **2.4. The price of HTS cables and transformers**

A key challenge for the HTS cables and HTS transformers is to keep bringing down the prices of superconductor tapes and refrigeration systems used in HTS technologies. The Bi-2223 or YBCO tapes are HTS materials and are used to produce HTS cable and HTS transformers. The present prices for Bi-2223 tapes is £96.1 – £128.1 / kAm (2009) which is adapted from [58],[59],[60],[61],[62],[63], while the price of copper conventional wire is £6.9 – £16 / kAm [62]. In [63] it was stated that the price of Bi-2223 tapes will reach £12.8/ kAm by 2016 - 2020 while another study [64] estimated that the price of Bi-2223 tapes will reach £6.4/kAm in the future. The present price of refrigeration systems is £62/W which is based on £620/m however, the price of refrigeration systems will be £16/W in the future which is based on £62/m [63],[65]. American Superconductor argues that the gap price between HTS transmission systems and conventional transmission systems is closed. The price of HTS cable at 5,000 megawatts would cost £5.2 to £8.3 million (M) per mile while the cost of conventional transmission systems at the same power capacity but at a higher voltage level is £4.5 to £6.4 M per mile [66]. Table 6 summarises the prices of HTS cables, based on the prices (Pounds) of Bi-2223 tapes, with refrigeration systems in the present and future.



Table 6: The prices of HTS cables and refrigeration systems in the present and future.

| The price of Bi-2223 tape and HTS cable |                         |                           |               |
|-----------------------------------------|-------------------------|---------------------------|---------------|
| Item                                    | Bi-2223tape, £/kA m,77K | Refrigeration systems £/m | HTS cable £/m |
| Now                                     | 96.1-128.1              | 620                       | 19.2k         |
| Future                                  | 12.8 - 6.4              | 62                        | 1.92-0.96k    |

Many studies have estimated the price of HTS transformers in the present and in the future. They have proved that the total price of HTS transformers is reliant on refrigeration system units and HTS tape. In [67], the present price of 30 MVA conventional transformers is £200,000 while the ownership costs for this transformer is in a range of £ 260,000 to £ 320,000. A cryocooled HTS transformer may be 30 percent higher in price and 10 percent higher in total owning cost than its conventional counterpart. Lower-cost versions should become available as HTS conductor cost and performance targets are achieved and refrigeration costs improved. ABB Asea Brown Boveri Ltd have estimated that the HTS transformer is more powerful at a higher rating (MVA) because it provides several advantages over conventional transformers such as lower operating losses, fault current limiting, lower impedance, better voltage regulation and a lower weight [48],[67]. Moreover, ABB Asea has performed conceptual studies that suggest a more than 20 percent reduction in capital cost, more than 50 percent reduction in weight, and nearly 70 percent reduction in losses for 100-MVA transformers utilizing HTS, as compared to conventional transformers[67]. Another example,[46], shows the comparison of capital cost between HTS and conventional transformers at the same MVA rating as that of the cost gap between 60 MVA HTS transformer and 60 MVA conventional transformer at £32.6k when the price of Bi-2223 or YBCO will be £19.2/ kAm. In [65] and [67] they have estimated the present prices of refrigeration systems for

HTS transformers at £62 /W at 77k while the target cost of cooling systems are £12.8 - £16/W. As a result, the total current price of HTS transformers (including refrigeration systems) is 10 to 30 percent higher than the total current price of conventional transformers, while the target price of HTS transformer is £620 per kg [67],[68]. Table 7 summarises the prices of HTS transformers, based on the price (Pounds) of Bi-2223 tapes, with refrigeration systems in the present and future.

Table 7: The prices of HTS transformers and refrigeration systems in the present and future.

| The price of Bi-2223 tape and HTS transformer |                        |                               |                          |
|-----------------------------------------------|------------------------|-------------------------------|--------------------------|
| Item                                          | Bi-2223tape,£/kA m,77K | Refrigeration systems £/W 77K | HTS transformer £        |
| Now                                           | 96.1-128.1             | 62                            | 10-30 % more             |
| Future                                        | 12.8                   | 16                            | £640 per Kg or 10 % more |

In the future, HTS cables and HTS transformers are expected to be more commonplace in distribution networks, which exist in urban environments. A lot of researches have estimated that the future price of HTS cables will be £1.92k- (2020) 0.96 k/m (2050) including refrigeration systems while the total future price of HTS transformers (including refrigeration systems) is 10 percent higher than the total current price of conventional transformers. Many researchers believe that HTS technologies will be one of the key technologies this century and the costs of HTS cable systems are expected to reduce through wider market access.

### 2.5. Applied HTS cables to urban environments

The power demand is increasing in developed countries each year such as the UK. The power demand in developed countries, especially in large cities such as London, will be increased, not only because of population growth but also because of urbanisation, new requirements such as electric vehicles and

improvement in living standards. Annual growth in power demand in the UK is expected to average 2.3% over the period 2011 to 2026 inclusive [3]. Researchers and developers on HTS transformers and HTS cables systems have an essential role to play in addressing these challenges. The HTS cables can be installed in cities to avoid digging up city streets and eliminate congestion network issues due to HTS cables that utilise superconductor materials with current densities ( HTS cables can transmit more power 3 to 5 times or more) than cables of the same diameter made with conventional copper cables [69]. Moreover, HTS transformers will be powerful in applying in urban environments to avoid additional costs of new substations to meet future power demand due to HTS transformers having higher power density than conventional transformers[48]. Increasing demand in urban environments leads to increasing issues in conventional power systems such as raising power losses and voltage regulator issues. However when HTS transformers and HTS cables are used in urban environments with long term demand , they will significantly reduce power losses and voltage regulator issues due to their impedances being very low [48]. Researchers and engineers believe that HTS cables and HTS transformers can address issues that are associated with conventional transformers and conventional cables such as reducing power losses and voltage regulators in big cities and urban environments. Moreover, they can transmit a high power density at lower voltage levels with more compact sizes than conventional copper cables and conventional transformers, which leads to a reduction of the cost of installing new substations to meet future demand in such areas.

## 2.6. Applied HTS cables to RE sources

The transmission of a large power produced from renewable energy plants such as solar energy and wind energy over long distances are accompanied by power losses caused by  $I^2R$  in transmission lines and distribution equipment. The HTS cables can transmit more power than cables of the same diameter made with conventional copper cables [69]. This issue can be avoided by using HTS DC cables instead of the conventional cables.

Wind farm capacities and transmission distances will be increased significantly in the UK Round 3 offshore wind farms creating a serious challenge when conventional HVDC transmission technologies are considered. There are two mainstream DC technologies for long distance high power transmission: Line-commutated converter (LCC) based on HVDC and Voltage source converter (VSC) based on HVDC. It would be useful to look at the challenges of applying these technologies with the future UK offshore wind farms to show how DC HTS cables could address the issues which exist in conventional HVDC technologies. The LCC technology makes use of thyristors, which need a strong AC network in order to commute and can only transfer power between two active AC networks. This means that LCC based HVDC transmission technology is problematic for application in the UK offshore farms because the offshore AC grid needs to be powered up prior to a potential start up. Moreover, the LCC based HVDC transmission technologies do not have independent control of the reactive and active powers, and therefore they require auxiliary services in order to fully control this power [70] [71]. The VSC based on HVDC technologies are only technology which could be applied with offshore wind farms because they are used IBGTS rather than thyristors [71]. By using VSC technology, several issues,

which are found in LCC, can be eliminated[72]. The main advantage of VSC HVDC technology is that it does not require a strong offshore or onshore AC network (so there is no need for an auxiliary service) and that it can be started up with no load. Moreover, the active and reactive power supplies can be controlled independently[72]. However, the use of VSC HVDC technologies with future UK offshore wind farms is challenged to deliver a high amount of power (GW) over hundreds of miles at lower voltage levels in terms of the reduced real power losses caused by DC conventional cables and lines. Therefore, the operating voltage needs to be increased to transmit a large amount of power at a higher voltage level to reduce the real power losses in DC conventional cables and lines. Increasing the voltage level for VSC converter stations is a challenge due to VSC converters that are faced with technical difficulties in operating at the same voltage level when they connect in serial [73]. In this case, they need additional equipment such as the H-Bridge (HB) to maintain the voltage level for such a VSC converter to operate at the same voltage level[73]. On other hand, delivering a large amount of power at a lower voltage level (by delivering a higher current) with VSC HVDC technologies would be easier to accomplish by connecting VSC converters in parallel; but, again this leads to an increase in the real power losses in conventional DC cables and lines[74].

The DC HTS cables have the opportunity to deliver power in GW at a low voltage level with lower power losses. Thus, they can be used with VSC technologies to deliver a high amount of power at a lower voltage level to overcome issues which have been mentioned above in applying conventional HVDC VSC technologies. This leads to a reduction in the capital cost of VSC converter substations (by connecting them in parallel, with no need to install HBs for converters) thus

reducing real power losses caused by DC transmission systems [75]. However, losses in a DC HTS cable system will be related to the conversion losses of the AC/DC terminals and the losses of the required cryogenic cooling system. State of the art VSC converter losses are approximately 1% per conversion, or 2% total for the line. For a 1600km, 5GW line, this has approximately 0.7% refrigeration losses or 0.35% for a 10GW line over the same distance [76]. According to American Superconductor Company, the DC HTS cables could transmit a greater amount of power (5 to 20 GW) [76] over long distances (800 to 1000 miles) in the future while conventional cables, such as point to point HVDC [25] overhead lines, could carry the same power over the same distances from one location of sources to another point of power at much higher power losses [25],[76].

Second part of chapter 2 reviews superconductor power systems: the work previously achieved in the DC and AC superconductor power systems and describes the materials and methods which they used. In addition, this part introduces the gaps and limitations in the research field the research described in the following chapters attempts to address these gaps and limitations.

## **2.7. DC superconductor power systems**

In [77],[78],[79] and [80] the comparison of power losses is introduced, and their economic impacts for high voltage DC transmission systems HVDC and DC HTS transmission systems over long distances (km). Power losses caused by these transmission systems have been studied using numerical simulations on Matlab/Simulink. These studies state that DC HTS cable can deliver power up to 10 times more than Thyristor-Based HVDC transmission systems. Additionally, DC HTS cables (without considering the power needs of refrigeration systems) have not resulted in any real losses ( $I^2R=0$ ) due their resistance being zero. The

cost of high insulation and converter substations are reduced due the possibility of delivering high power density at a lower voltage level. In [81], the optimum voltage level of converter substations in order to reduce cost was estimated as in range from 50kV to 100kV.

Other studies, for example [82] and [83] provide the possibility of applying DC HTS cables to distribution power systems in urban areas. It is shown that implementing DC HTS cables into urban areas can eliminate real power losses, increase power density of each feeder and reduce the cost of converter stations and substations. Elsewhere, for example, [84], the opportunity of operating low voltage DC superconductor distribution networks in urban areas has been introduced. In addition, the method of power sharing control between rectifiers has been introduced in DC superconductor distributing networks including various distributed generators ( $DG_S$ ).

Other studies, [76],[75],[85] and [86], conducted research looking at the possibility of applying DC HTS cables to transmit high amounts of power (GW) over long distances (km). DC HTS transmission systems can be implemented with VSC at lower voltage to reduce costs of converter substations. The opportunity of using DC HTS transmission systems based on VSC provides the possibility of applying this technology to future offshore farms to deliver power over long distances.

Furthermore, the impact of harmonic current on steady state of DC HTS cables has been investigated [87],[88]. The harmonic current does not impact on the steady state of DC HTS cable. In addition, the possibility the low voltage DC superconductor distribution to feed sensitive electric load such as office

environment has been discussed in [87] and [89]. However, [87] proved that there is no need to apply rectifier or power factor correction (power factor correction for AC network sides) to reduce power losses in networks while [89] proposed the new control scheme of voltage source inverter (VSI) and proposed to allow the system to supply multiple passive loads without a central communication unit .

[90] and [91] discuss the power control applications of low voltage DC superconductor mesh networks. The DC superconductor cables can be applied to mesh networks at a low voltage (10-15kV). This leads to a decrease in the number of transformers required, and a subsequent reduction in the cost of high voltage insulation. Each of the nodes on a DC superconductor system reaches the same steady-state voltage level because the DC superconductor cables do not provide DC resistance to cause terminal voltage to vary with line current magnitudes. Thus, it is possible to use the voltage in a DC superconductor system as a signal to identify where the demand has increased in the mesh network loads. If the demand has decreased, then the voltage in the nodes has increased, and if the voltage in the nodes has decreased then the demand has increased.

## **2.8. AC Superconductor power systems**

The impact of the unique characteristics of AC HTS cables on their power transfer performance and its needs for reactive compensation has been studied [92]. The results show that the regulation voltage was better when AC HTS cables were considered. When overhead lines carry a small amount of power, the voltage profile along the line is uniform and requires little compensation. On the other hand, as the power increases in overhead lines, the capacitive compensation increases. In underground cables, the voltage profile along the line is higher than the normal value and therefore it requires inductive shunt compensation after



50km at intermediate points. However, a very low impedance of AC HTS cables provide better voltage regulation in the system, but the charging current for superconductor cables is large even though the voltage regulation is excellent. This study of AC HTS cables showed that cable lengths could reach over 175km before compensation was needed at intermediate points.

Several studies have concluded that AC HTS technologies such as HTS transformers and HTS cables can be ideal to implement in distribution power systems in urban areas. [93],[94],[95] and [96] proposed that HTS cables will be overcome on obstacles which face conventional technologies in urban areas such as reduced voltage drop, reduced power losses, reduced CO<sub>2</sub> emissions and increased power density. AC HTS cables can transmit bulk capacity with lower voltage (<50kV) and lower losses therefore they can reduce the need of high voltage substations which leads to reduced costs of substations in urban areas. The environment-friendly nature of the HTS cables is expected to bring huge environmental and social benefits including fewer civil petitions over environmental issues in urban areas. In [94] proved that there is an increasing interest in installing HTS cables to an highly populated metropolitan area to significantly improve power transmission capacity with minimal electrical loss. This study calculated of the electrical losses of 100 kV, 50 km transmission lines where the load demands 100 MVA with 0.95 power factor. The power consumption of refrigeration systems for HTS cables have not been discussed in these studies due to the fact that power is considered a real power loss for AC HTS cables, consequently this gap must be considered when determining power losses for superconductor distribution networks. Furthermore, the power losses

and voltage fluctuations in superconductor distribution networks need to be investigated when loads are a lagging, leading and unity power factor.

Other studies have introduced the advantages of applying AC HTS transformers in urban areas over conventional transformers. In [48],[53],[54]and[55] it is emphasised that implementing HTS transformers to urban areas leads to an overcoming of issues which are associated with conventional transformers such as increased power density, reduced operating losses, lower impedance, smaller weight, smaller size and better voltage regulation.

[97] introduced an economic analysis to implement AC HTS cable in urban areas. This study consisted of six case studies, which applied AC HTS cable, and suggested the best choice among these studies by means of cost analysis. The conclusion is that applying AC HTS cables to the Seoul system will reduce the number of required underground cables by 25%, transmission losses by 3.5% and construction costs by \$1.736 million by 2035 when compared to conventional cables. This study did not consider the cost of refrigeration systems and has not provided the prices of BSCCO materials which are major factors in dropping the price of AC HTS cable and HTS transformers. Furthermore, this study did not introduce a suitable price of AC HTS cables and HTS transformers when they will be competitive to conventional technologies based on the future price of Bi-2223. Therefore, the optimum application of applying HTS technologies to distribution networks needs to be introduced to result in lower capital cost than distribution conventional networks.

There are some researchers who have concentrated on AC loss in HTS cable. [98] is more specific, and focuses on AC losses and thermal considerations for AC superconductor cables. AC superconductor power systems are not evaluated by

their critical current density, but by the requirements for acceptable loss and reactive compensation. Operational limits for long length AC superconductor power systems depend upon: the cooling configuration; the AC superconducting cable loss, and the thermal loss. An analysis of liquid nitrogen cooling systems and electrical insulation contraction for AC superconducting cables is presented in [99].

New design topologies of distribution networks in urban areas can be achieved using AC HTS cables. In [100],[101],[102] and [103], the power can be supplied from 220kV down to low voltage levels such as 10kV,20kV,25kV or 35kV. These studies confirmed that implementing AC HTS cables to distribution power systems can reduce the cost of transformer-substations and switchgear. Investigating the reliability, power losses, and cost for new design of superconductor networks are introduced in these papers. However, the optimum application of implemented HTS cables and HTS transformers to urban areas has not been introduced in order to reduce power losses, voltage drop issues and reducing the cost of transformer-substations. Hence, the future demand in urban areas must be considered to show the AC HTS technologies can be covered coup with future issues which will be associated with conventional technologies such as power losses, voltage regulator issues and the cost of installing new cables and substations to meet such demand.

Mathias Noe and et al. introduced several scenarios studies of superconductor networks to deliver power from extra high voltage level (380kV) to medium voltage level (30kV). This study introduced the notion that applying AC HTS cables to urban areas leads to reduce number of voltage levels, higher power rating per feeder, lower losses and high stability. Moreover, the n-1 criterion was

considered for all investigations to guarantee the necessary reliability and redundancy. However, the risk study for superconductor distribution systems has not been introduced yet, therefore, it is necessary to evaluate risk levels in superconductor distribution networks and compare to conventional distribution systems.

Due to the fact that HTS cables and transformers have very low impedances, the fault current level in the superconductor network is high. Using a conventional fault current as a solution in AC superconductor networks leads to unwanted side effects for the networks such as an increase in network losses, voltage regulation problems or compromised system stability [30]. Therefore, the superconducting fault current limiters (SFCL) can be used to limit the short-circuit current level in electrical transmission and distribution network.

HTS materials have been used in order to enhance the performance of fault current devices. The matrix fault current limiter (MFCL) based on HTS materials which were introduced in papers [30], [112], [113], [114] and [115]. MFCLs are designed to address fault current over-duty problems at a transmission voltage level of 138kV. MFCL devices consist of an HTS element variable resistor in parallel with a reactor. Under normal operating conditions, the peak current level of the power transmission is less than the critical current of the HTS element, and there is no voltages drop in the device because the resistance of the HTS elements is almost zero, which leads to a reduction in  $I^2R$  losses. When fault current occurs, the AC current will be higher than the critical current in the HTS element. This will result in creating a high resistance in the MFCL device, which will force the interruption of the fault current in the grid. Another application of MFCL devices in the power grid is when new a generator connects to the transmission grid, the

fault current will increase. This requires upgrading conventional circuit breakers in the grid and this will be expensive and will include a voltage drop, with added power losses and stability problems in the grid. The MFCL devices can be connected directly to a new generator without upgrading the breakers in the grid [30]. The MFCL devices can clear the fault current without the need to open the breakers in the grid. Currently, there are many companies working on developing this device such as Superpower and Nexans Superconductors for utility transmission networks [30].

[113] introduces also resistance type SFCL can be used with a transformer to reduce fault current level issues in the distribution networks. The resistive type of SFCL using a transformer consists of a transformer and an HTS element which is connected with the secondary winding of the transformer. It is a function of the turn number's ratio between primary and secondary winding to limit resistance of HTS element in a transformer to reduce fault level current issues in the network.

In addition, SFCL devices can be applied to low voltage AC distribution grids. When a new generator connects to a distribution grid in order to meet increasing demand, the fault current level in the grid will increase. This requires the creation of a new configuration of substations and breaker circuits. In this case, conventional breaker circuits cannot interrupt the current fault due to its magnitude. Using resistive SFCL devices in the distribution grids requires a connection to the breaker circuit because resistive SFCL devices increase mitigating the fault current level to that breaker current handle it [114],[115].

## **2.9. Summary**

In light of the present literature review, the main research trends regarding the various relevant topics have been identified. Although some research has been done for applying HTS assets into power systems, but more necessary research is required to be considered in this thesis to explore more about the opportunities and challenges of superconductor power systems. Further research in this thesis needs to be carried out to address the research questions, which are obtained from the literature review, to introduce the opportunities of using HTS assets into power systems to overcome current and future obstacles which would face conventional power systems in the future.

The first issue that needs to be addressed is the impact of HTS cables and transformers on AC electrical distribution networks. This study will also describe the research carried out to investigate the impact of AC superconducting power transmission on real and reactive power losses, voltage fluctuations and fault levels and DG for a LV distribution network when Cold-Dielectric (CD) AC HTS cables are considered. An LV conventional power system and those containing AC HTS cables and transformers will be compared and conclusions drawn regarding the likely impact of superconducting cables on the design and operation of future power systems.

### **3. Impact of HTS technologies on distribution and transmission power systems**

The previous chapter highlighted the need to investigate the impacts of AC superconducting power transmission on real and reactive power losses, voltage direction change and fault levels for an existing UK LV distribution network when Cold-Dielectric (CD) AC HTS cables are considered. Comparisons between existing conventional power systems and those containing AC superconducting cable are made and conclusions drawn regarding the likely impact of superconducting cables on the operation of future power systems.

Distribution networks are the final link between transmission networks and electricity consumers. Recent developments in distribution networks have drawn the attention of utility companies to reduce power losses and improve voltage control. Increased incidence of power losses and voltage excursions in distribution networks has a negative impact on both consumers and the utility company. As electrical power consumption and transmission distances increase power losses in distribution networks become increasingly important, especially in large cities and urban areas. In developed countries, the power losses associated with distribution networks are in the region of 10 %; therefore utility companies are currently interested in minimising the power losses in distribution systems [1].

There are several techniques implemented in distribution networks to reduce the voltage excursions and power losses such as: distributed generators (DG) power and power factor control, capacitor placement and transformer tap change control [104],[105]. These techniques often result in increased capital and operational costs. A key research challenge is to cost effectively and reliably make use of new

conductor materials with extremely low resistivity in order to eliminate/reduce the power losses present in conventional transmission systems while also addressing voltage control concerns.

HTS materials have zero resistance when cooled to the boiling point of liquid nitrogen (77K) interest in using these materials for power transmission is growing rapidly [12],[13]. AC HTS cables can deliver significantly more power (3–5 times) than conventional cables and hence provide the opportunity to reduce grid congestion [69]. Moreover AC HTS cables contain very low impedance; therefore they can reduce the power losses and voltage control problems associated with conventional conductors. Although implementing an AC distribution system with HTS cables results in AC power losses such as hysteric losses and eddy current losses, these AC losses are still much lower than those resulting from conventional power system conductors [98]. Although the real losses in AC HTS conductors are very low they are still present and they increase as the AC current increases. Therefore research and development is still required to attempt to decrease AC losses in HTS cables [90].

### **3.1. Power losses in AC distribution networks**

Power losses in distribution networks are divided into two categories: real power and reactive power losses [106]. The resistance of the conductor causes real power losses in distribution networks, while the reactive power losses in distribution networks arises from reactance elements. Reducing the real power losses in distribution networks is an important challenge for utilities as this is the predominant part of most customers' demand [107]. Nevertheless, reactive power losses in distribution networks are still an important consideration not least because of their link with voltage control problems in distribution networks



[108],[109]. In developed countries such as the UK, the power demand usually increases leading to increased power losses in distribution networks when conventional conductors are considered. However, there are several methods to reduce the losses in distribution networks. This includes controlling the real power and power factor of DG [110]. The total power loss in a distribution network can be determined by equations 1 and 2.

$$P_{\text{loss}} = \sum_{i=1}^{N_{\text{br}}} |I_i|^2 R_i \quad (1)$$

$$Q_{\text{loss}} = \sum_{i=1}^{N_{\text{br}}} |I_i|^2 X_i \quad (2)$$

Where,  $N_{\text{br}}$  is the number of branches in the distribution network;  $I_i$  is the magnitude of current flow in the branch and  $R_i$  and  $X_i$  are the reactance and resistance of the branch  $r$  respectively.

### 3.2. Voltage control in distribution networks

Voltage control problems exist in many distribution networks especially those operating at lower voltage levels. Voltage control problems are at their most acute in lower voltage, weak, networks that feed large loads over relatively long distances at a poor power factor potentially leading to voltage drops [1]. Distribution network voltages must be maintained within statutory limits in order to comply with regulations and also to provide a sufficient power quality for customers [111]. The voltage drop in distribution networks can be approximated by equation 3[8].

$$\Delta V = \frac{(RP + XQ)}{V} + j \frac{(XP - RQ)}{V} \quad (3)$$

Where, the  $\Delta V$  is the voltage change in the system from sending to receiving end busbars;  $P$  and  $Q$  are the active and reactive power loads,  $R$  and  $X$  are resistance and reactance respectively and  $V$  is the sending end voltage.

It is useful to derive equation 3 to understand how the voltage drops occur in a network.

A simple transmission link is shown in figure 8. A phasor diagram for transmission of power through serial impedance in a network is required to be established based on  $(E)$  voltage sources,  $V$  the sending end voltage in a network,  $(\theta)$  power angle and  $(\delta)$  phase angle.

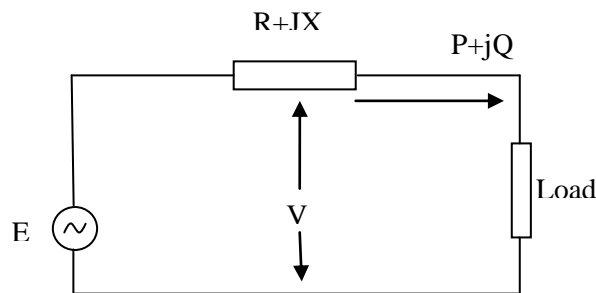

Figure 8: A simple transmission link

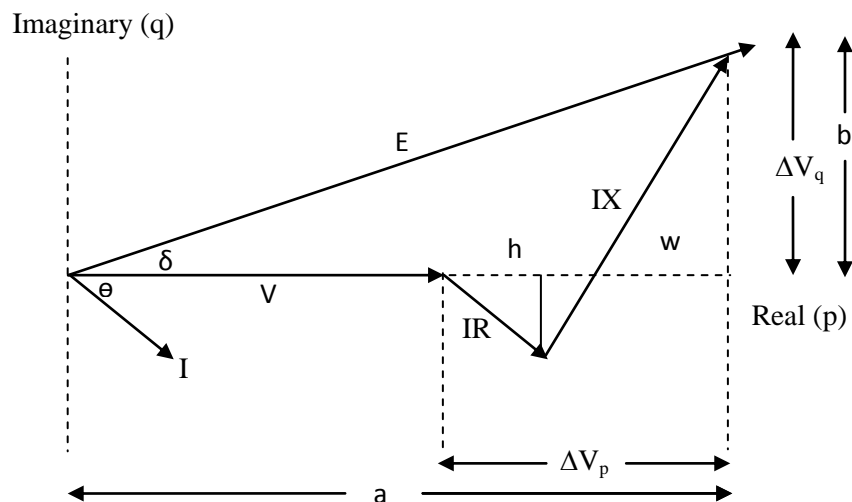

Figure 9: Phasor diagram for transmission of power through a serial impedance

The power is delivered in a network as complex power ( $S$ ) where its real part is the average (real) power  $P$  and its imaginary part is the reactive power  $Q$ . Thus, the complex power is designated by  $S$  which is given by equation 4[8].

$$S = VI^* = P + jQ \quad (4)$$

Where  $S$  is a complex power,  $V$  is the voltage level in the network and  $I^*$  is the complex current.

The serial impedance ( $Z$ ) of a network also consists of real and imaginary parts. The impedance of the network can be represented as shown in equation 5[8].

$$Z = R + jX \quad (5)$$

$R$  and  $X$  are the resistance and reactance of the network.

Therefore, a voltage drop in a network has to be considered the voltage drop cause by delivering real and reactive power. The cause of the voltage drop by delivering real power in the network relies on the voltage drop which occurs in resistance ( $R$ ) in the network while the cause of the voltage drop in delivering reactive power in the network relies on the voltage drop occurring in reactance ( $X$ ) in the network.

Figure 9 shows that the imaginary and real parts of power, which are  $X$  and  $Y$  axes. The load impedance is assumed to be inductive, therefore the current ( $I$ ) lags voltage ( $V$ ).

$E$  can be obtaining from figure 9 as follows:

$$E^2 = (a)^2 + (b)^2$$

$$= (V + \Delta V_p)^2 + (\Delta V_q)^2$$

Then equation 6 is shown; the final equation of E:

$$E^2 = (V + RI\cos\theta + XI\sin\delta)^2 + (XI\cos\theta - RI\sin\theta)^2 \quad (6)$$

From figure 9, the length w and h can be found as shown in 7 and 8:

$$\sin\delta = \frac{w}{IX} \quad (7)$$

$$\cos\theta = \frac{h}{IR} \quad (8)$$

Hence:

$$E^2 = \underbrace{\left(V + \frac{RP}{V} + \frac{XQ}{V}\right)^2}_{\text{Real part}} + \underbrace{\left(\frac{RQ}{V} - \frac{XP}{V}\right)^2}_{\text{Imaginary part}} \quad (9)$$

From equation 9, the voltage drop in the real part can be shown in 10:

$$E - V = \frac{RP + XQ}{V} \quad (10)$$

Also, the voltage drop in the imaginary part can be shown in 11:

$$\Delta V_q = \frac{RQ - XP}{V} \quad (11)$$

Hence the arithmetic difference between the voltages is given approximately by equation 12:

$$\Delta V_p = \frac{RP + XQ}{V} \quad (12)$$

The voltage drop in a network is the summation of the voltage drop which occurred in the real and imaginary parts which is a summation of equations 11 and 12 as shown in equation 13:

$$\Delta V = \Delta V_p + j\Delta V_q \quad (13)$$

Hence:

$$\Delta V = \frac{(RP + XQ)}{V} + j \frac{(XP - RQ)}{V}$$

This study describes research carried out to investigate the impacts of AC superconducting power transmission on the real and reactive power losses, voltage change, FLs and DG for an existing UK LV<sub>6.6kV</sub> distribution network when CD HTS cables are considered. The main reason for selecting this network is that there is a voltage drop and higher power loss issues in this network at lagging power factor for loads. Therefore, this would be a good case study to show the positive impact of using HTS technologies with this network in terms of overcoming such issues. Also, the study introduces whether incorporated HTS technologies with LV distribution networks can be a solution to avoid serious problems which are associated with LV conventional distribution networks such as increased power demand, reduced power losses and eliminated voltage drop issues in networks.

### **3.3. Description of the distribution network model**

The first step in comparing the performance of CD HTS cables with conventional cables was to build a model of the existing UK LV<sub>6.6kV</sub> distribution network. The distribution network was developed using IPSA software using the real parameters of each component of the network. The network consists of 55 loads,

two transformers, distributed generation (DG) and (32km) of overhead lines and underground cables. Figure 10 shows for the LV<sub>6.6</sub> kV distribution network with 25 composite loads.

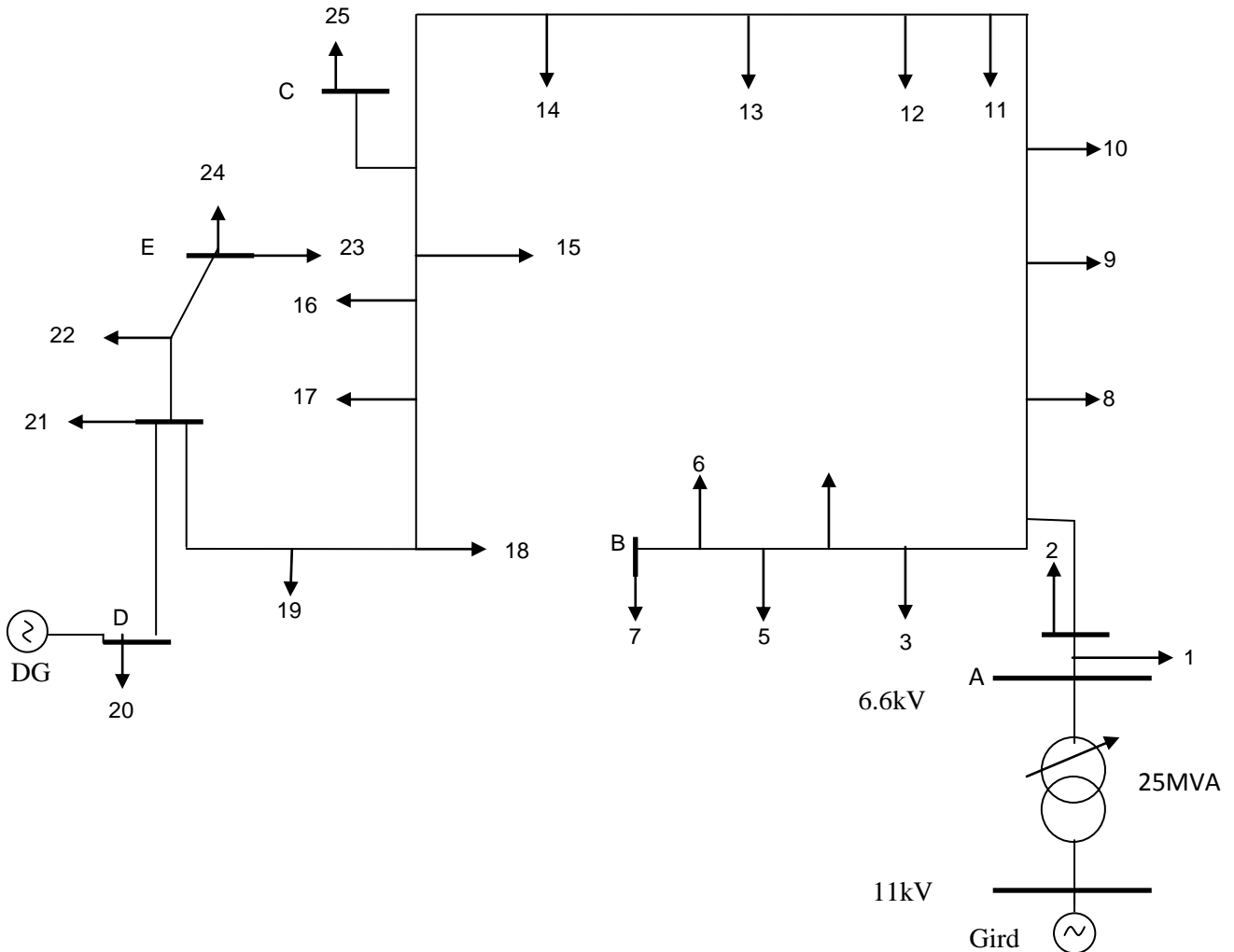

Figure 10: The IPSA model for LV<sub>6.6</sub>kV distribution network with composite loads

### 3.4. Analysis of power losses in a conventional distribution network

Sensitivity analysis was performed to determine the amount of power losses incurred in the distribution network. Power losses are determined by applying different demands with different power factors for the following loads: 0.98 lagging, unity and 0.98 leading. The analysis of power losses will also include networks without and with DG.

### 3.4.1. Without distributed generators (DG)

An analysis of power losses in the conventional distribution network was carried out without connecting DG to the network. The X/R ratio for this low voltage distribution network was less than one, therefore resistance dominates and the real power losses are significant during heavy loading periods. When the power factor was 0.98 lagging, the reactive power consumption increased in the distribution network because of the inductive load. The losses were at their highest when the loads were set at 0.98 power factor lagging. The power losses were reduced, when the power factor was unity. In this case, reactive power was not consumed by loads. This led to reduced power losses in the distribution network. The lowest power losses in the distribution network occurred when the power factor of the loads was 0.98 leading therefore the loads were compensating for the reactive power demand of the network components. The voltage drops were also at their lowest for the leading power factor case.

To investigate the power losses in a superconductor distribution system, all of the conventional cables and lines were replaced with CD HTS cables. Analysis of power losses was acquired by applying different power factors for loads with different demands. The reactance of the distribution network was now greater than the resistance ( $X > R$ ) when the CD HTS cables were considered. The power losses in distribution networks are reduced significantly when CD HTS cables are applied. CD HTS cables have very low impedances; which reduces power losses. The power loss was highest in the 0.98 lagging power factor for loads but remained much less than the network using conventional cables under the same conditions. The results regarding the maximum real and reactive power losses in the conventional distribution network are 0.2 MW and 0.1 MVA<sub>r</sub> respectively and

this occurs when the power factor is 0.98 lagging, while the maximum real and reactive power losses in the superconductor distribution network for the same operating conditions are 0.001 MW and 0.05 MVar respectively.

#### **3.4.2. With DG**

Five busbars were selected to investigate voltage changes and power losses in the UK distribution network. The DG was located at busbar D as shown in figure 10. Distributed generator can result in some cases in reducing the power losses in distribution networks. This can be achieved by controlling the real power and reactive power of the distributed generator. For study network, a 32% reduction in power losses was observed when the DG was connected. The power losses were also reduced in a superconductor distribution network when the DG was connected. However the reduction of power losses in the superconductor distribution network was not significant when the DG was operated because the CD HTS cables have very low impedances. The power losses when the DG was connected were approximately 15 % less than without the DG for the superconductor network.

#### **3.5. Voltage changes in conventional distribution network versus superconductor distribution network**

The voltage level in the distribution network must be maintained within a predefined range at all times regardless of loading. For the existing UK distribution network, the voltage level in the 6.6 kV network must be kept within  $\pm 0.06$  (pu). Transformers with on load tap changers are used to control voltage levels in the distribution network. The voltage change in the conventional distribution network was investigated using different power factors for the loads and with different power demands. These results were then compared to the



distribution network containing CD HTS cables. These investigations were also carried out with and without the DG connected.

### **3.5.1. Without DG**

As expected, the voltage drop in the superconductor distribution network was much less than that of the existing UK distribution network. The CD HTS cables contain capacitive reactance that generates reactive power which tends to increase the voltage in the network. The maximum voltage drop in the existing UK distribution network was 0.13 pu when the power factor was 0.98 lagging, while the maximum voltage drop in the superconductor distribution network, under the same conditions, was 0.0021 pu.

The voltage drop in the conventional distribution network was reduced when the power factor was 0.98 leading for the loads. Capacitive loads generated reactive power in the distribution network, therefore the voltage drop in the network decreased.

Figures 11 and 12 present the voltage changes, per unit, for five busbars in the superconductor and conventional distribution networks. The reason for selecting five busbars in different locations (as shown in figure 10) in the network is to investigate the voltage changes in the whole network as a power factor for load changes. The figures show that the voltage actually increases as the demand increases in the superconductor network. This is because the reactive power being produced by the loads also increases and increases the voltage level.

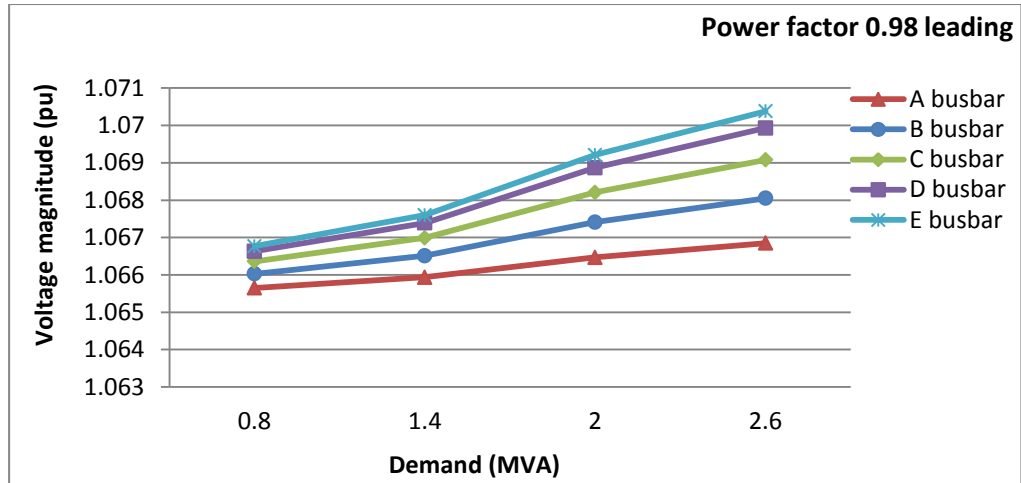

Figure 11: Voltage change in the superconductor distribution network.

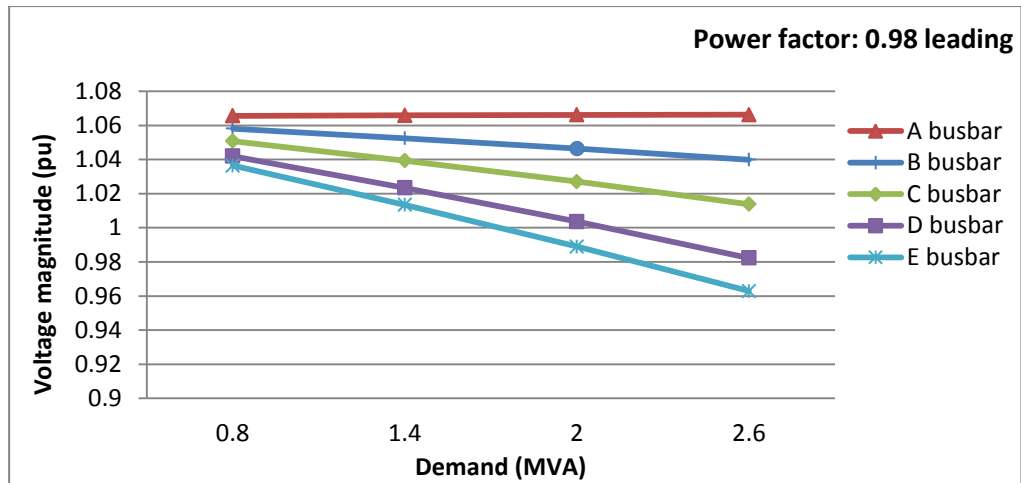

Figure 12: Voltage change in conventional distribution network.

### 3.6. Fault level (FL) studies

A number of FL investigations were carried out on the conventional and superconducting distribution networks. The FLs in the distribution network, comprising CD HTS cables were considered, were much greater than those in the conventional distribution network. This is due to the low impedance of the CD HTS cables. The FL at busbar E when CD HTS cables were considered was 70 MVA whereas for conventional conductors the fault level was 12 MVA. The reason to measure the fault level in only E busbar is because it resulted in the

highest fault level which occurred in both cases. The FL in distribution networks is expressed by equation 14.

$$FL = \sqrt{3} \times I_f \times V_{\text{normal}} \text{ (MVA)} \quad (14)$$

Where,  $I_f$  is the fault current of cables in the distribution network is the  $V_{\text{normal}}$  operation voltage of distribution networks, and FL is the fault level in the distribution networks.

When the DG was connected to the conventional distribution network, the FL in the network increased particularly at busbars close to the point of DG connection. Implementation of DG on the distribution network which contained CD HTS cables led to a further increase in FLs. The FL in busbar E with DG implemented in the CD HTS network increased significantly to 400MVA whereas for the conventional power network it only increased to 25 MVA. This emphasises the fact that superconducting cables present real issues with respect to fault management in distribution networks. However, superconductor SFCL devices can be used to overcome fault level issues for superconductor distribution and transmission systems. SFCL devices provide the necessary current limiting impedance during a fault with essentially zero impedance during normal grid operation. SFCLs have no negative impact on overall system performance [112] [113]. The function of SFCLs is based on adding impedance to HTS cables and transformers that are required to protect the superconductor from destructive hot spots during the quench [114],[115]. More information has been represented in chapter 2 about using SFCLs to eliminate the fault level issues in distribution and transmission power systems.

The analysis performed in this study has demonstrated the impact of AC HTS on power losses, voltage drop and FLs in low voltage distribution networks. Moreover, it has evaluated the impact of DG on both superconductor and conventional distribution networks. Power losses and voltage drops are decreased significantly (up to 86 %) when CD HTS cables are considered. The maximum voltage drop in the low voltage conventional distribution network was 0.1 per unit when the power factor was 0.98 lagging, while the maximum voltage drop in the superconductor distribution network in the same operating conditions was 0.0021 per unit. Voltage drops in a distribution network which contains CD HTS cables are reduced significantly. This means that superconducting distribution networks offer not only benefits associated with reduced losses and an alleviation of voltage control problems. Applying DG to the superconductor distribution network did not have a significant effect on voltages or losses due to CD HTS cables having very low impedances, but it did increase FL in the distribution network. FL in distribution networks with DG implemented when CD HTS cables are present was about 5 times higher than that of distribution networks when conventional cables are used for the same power rating. However, SFCLs can be a solution to overcome fault level issues with superconductor power systems

The change on voltage direction in the superconductor distribution network was different from conventional distribution network when a power factor for loads was leading. The voltage increases as the demand increases in the superconductor network. In addition, the voltage drop in a superconductor distribution network is very small and this is extremely valuable as it simplifies the voltage control. However, conventional reactive power sharing techniques rely upon voltage magnitude changes to function correctly. This raises the question, addressed by

the next chapter, which relates to the extent to which conventional techniques can be applied to HTS power systems to achieve reactive power sharing in the absence of relatively large voltage changes.

The research has demonstrated that power losses in HTS cables were up to 86% less than those in conventional cables and lines, however, HTS technologies need to operate at a temperature of no more than 77K, which is the boiling point of liquid nitrogen, to provide very low impedance. Therefore, it is necessary to use refrigeration systems to keep the temperature of HTS cables and HTS transformers at 77K. Power consumption by refrigeration systems must be added to the real power losses of HTS cables and transformers to find the total real power losses in the whole superconductor distribution network. The next chapter calculates power losses in HTS cables and HTS transformers including the power needs of their refrigeration systems, and then compares these to power losses incurred in conventional distribution and transmission power systems.

From this conclusion and from literature review (chapter 2), the remaining question to be addressed in this chapter refers to the impact of HTS cables on DC transmission networks. DC transmission networks will be implemented with future offshore wind farms which will be located far away from the grid. Future challenges include the transmission of large amounts of power over long distances with low real losses ( $I^2R$ ). The dominant source of real losses in conventional power systems occurs in the transmission system. Therefore the possibility of using DC cables for future offshore wind farms will be introduced to address these issues. A case study of a large future offshore wind farm will be used to investigate the impact of applying DC HTS cables on offshore wind farms. In addition, the possibility of applying conventional transmission technologies with

future offshore wind farms needs to be introduced along with the challenges which will face these technologies. Lastly, the potential of DC HTS cables will be assessed for this application.

### **3.7. The impact of HTS cables on the DC transmission networks**

This section assesses the potential for using DC HTS cables within transmission networks for large offshore farms and compares this with conventional transmission networks. The challenges facing the application of conventional transmission networks to future offshore wind farms will be assessed and the role that DC HTS transmission networks could have in addressing these issues will be investigated.

HTS cables have the potential to deliver higher amounts of power at a lower voltage level. They provide zero real power losses when maintains at 77K. Wind farm capacities and transmission distances will be increased significantly in the UK Round 3 offshore wind farms creating a serious challenge when conventional HVDC transmission technologies are considered. The main purpose of HTS cables as the transmission conductor in HVDC transmission systems to reduce the real losses ( $I^2R$ ) arising from the power transmission process.

The exploitation of wind energy is increasing as countries such as the UK attempt to decarbonise their electricity industry and meet increasing power demands efficiently. Currently, the largest existing offshore wind farms in Britain included Thanet offshore wind farm, with a power capacity of 300MW and Lynn and Inner Dowsing, with a power capacity of 194MW [14]. Future offshore wind projects will increase the capacity and number of turbines with wind farm capacities in the GW region. These future offshore wind farms will be located hundreds of km from the shore [70]. By 2020, the United Kingdom plans to have increased the

capacity of offshore wind farms to 25GW [14],[15]. Therefore a future challenge will be to transmit large amounts of power over long distances with low real losses ( $I^2R$ ). The dominant source of joule losses in conventional power systems occurs in the transmission system. A key research challenge is to cost effectively and reliably make use of new conductor materials with extremely low resistivity in order to eliminate/reduce the real losses present in conventional transmission systems. Since HTS materials have almost zero resistance when cooled to the boiling point of liquid nitrogen (77K), interest in using these materials for the transmission of power is increasing significantly [116]. The maximum current that a DC HTS cable can carry with zero resistance is known as its critical current. A Current greater than critical current ( $I_C$ ) will cause the DC HTS cable to revert to its normal state [77].The real loss in a DC HTS cable is negligible when operated below its critical current. Thus, DC HTS cables have the potential to address the challenge of delivering a large amount power over greater distances in the future, for example the UK Round 3 offshore winds farms.

A comparison will be made between voltage source converters (VSC) based on DC HTS and VSC based on conventional HVDC transmission technologies in the delivery of 1.2375MW (from 165 Clipper Wind Britannia turbines of 7.5MW capacity) from Dogger Bank zone H3 offshore wind farm over a distance of 273km [14]. These comparisons focus on both power losses and economic aspects. These investigations were carried out using two IPSA models, namely the 275kV HVDC and 100kV DC HTS transmission systems.

### **3.8. The application of HVDC transmission technologies in the UK Round 3 offshore wind farms**

Between 1954 and 2012, more than 50 HVDC projects [117], were implemented in several parts of the world. The voltage levels of these projects ranged from 100 kV (in 1950 in Sweden) to 800 kV (2007 in China) [118],[119], and the rated power from 20MW to 5000MW (future projects with 6-7GW or even higher are in the planning stages) [119],[120]. The distance ranged from 112 to 1438 km however, DC power at a low voltage is not economical to deliver over long distances with conventional systems, meaning that high voltage AC electrical systems are used instead. On the other hand, with the development of high voltage valves, it is now possible to transmit DC power at a high voltage and over long distances, giving rise to HVDC transmission systems [72],[121].

For many years, HVDC transmission systems have demonstrated the ability to transmit power over long distances (thousands of miles), with reduced power losses compared to those in HVAC transmission systems. Overhead HVDC transmission systems are suitable for delivering power from 1 to 5GW over long distances ( $\geq 600\text{km}$ ) [119]. Furthermore, the transmission of power of up to 600-800MW over distances of 300km with HVDC systems has already been accomplished with submarine cables. Cable transmission lengths of up to 1000km are at the planning stage [119]. It is therefore evident that it is feasible to use HVDC transmission technology for the UK Round 3 offshore farms. There are two mainstream HVDC technologies for long distance high power transmission: Line-commutated converter (LCC) based HVDC and Voltage source converter (VSC) based on HVDC.



The LCC technology makes use of thyristors, which need a strong AC network in order to commutate and can only transfer power between two active AC networks. This means that LCC based HVDC transmission technology is problematic for application in the UK Round 3 offshore farms because the offshore AC grid needs to be powered up prior to a potential start up. Moreover, the LCC based HVDC transmission technologies do not have independent control of the reactive and active powers, and therefore they require auxiliary services in order to fully control this power. In addition, they produce a relatively large harmonic current which causes power loss in the DC submarine cables. In order to remove the harmonic current from the HVDC transmission systems, a number of filters need to be installed. This leads to an increase in the cost of converter substations [71]. Based on the overall economics of the system, LCC based HVDC submarine transmission can cost effectively deliver power up to 600MW [74]. However, these issues do not exist in VSC technologies because they use insulated gate bipolar transistors, IGBTs instead of thyristors; therefore they are more suited to the UK Round 3 offshore wind farms. An understanding of the feasibility of using Voltage source converter (VSC) HVDC transmission technologies with the UK Round 3 offshore farms is required in order to identify the requirements and challenges of such technology.

### **3.8.1. Voltage source converter based on HVDC**

VSC HVDC technology consists of the following main components: an AC based collector system within the wind farm; offshore substations with the relevant converters and a DC cable pair for connecting the offshore substation to an onshore converter station. VSC converters (IGBT) instead of thyristors. By using VSC technology, several issues, which are found in LCC, can be eliminated. The

main advantage of VSC HVDC technology is that it does not require a strong offshore or onshore AC network (so there is no need for an auxiliary service) and that it can be started up with no load. This is made possible because in a VSC (IGBT), the current can be switched off, negating the need for an active commutation voltage. Moreover, the active and reactive power supplies can be controlled independently. However, currently, the maximum power rating per converter is limited to 300-350MW at 150kV, while the cable rating at  $\pm 150\text{kV}$  is 600MW [71],[122] as shown in Figure 13.

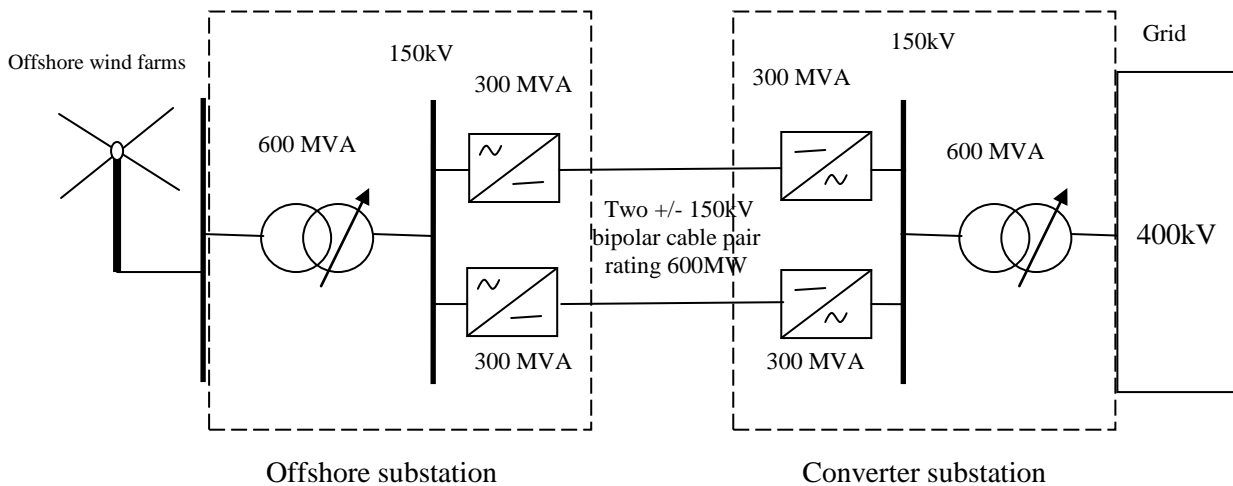

Figure 13: VSC based of HVDC transmission systems.

### 3.8.1.1. The challenges of VSC based on HVDC transmission systems

The power losses produced, per converter station, in VSC HVDC technology are more than the power losses produced per converter station in LCC HVDC technologies. The total power losses in VSC HVDC transmission systems are 4 to 6% of the total power being delivered, while the total power losses in LCC HVDC transmission systems are 2 to 3% [71]. On the other hand, VSCs produce low levels of harmonics and this means that there is a reduced need to install filters in

offshore substations. The maximum power rating for a VSC at  $\pm 150\text{kV}$  is 300MW, while the DC cable rating at  $\pm 150\text{kV}$  is 600MW. Consequently, if more than 300 MW is to be transported, the number of VSC stations has to be increased and the transmission voltage also has to be increased. This will increase the cost of VSC HVDC technology [71]. There are many studies which have concentrated on how to increase the capacity of VSCs and HVDC submarines cables. With respect to the transmission of UK Round 3 offshore farm projects, point-to-point HVDC submarine cables do not address the need to aggregate energy from multiple offshore farms, or the need to deliver power to multiple points. Currently, in HVDC transmission systems, controlling multi-terminal configurations is quite difficult, because of many issues such as the resulting requirements it places on DC breakers [91]. DC circuit breakers are more difficult to design and use than AC circuit breakers. AC circuit breakers have the advantage that a current zero occurs twice per cycle which assists with arc extinction. However, DC circuit breakers do not have this natural advantage and therefore it is more challenging to build HVDC multi-terminal systems [122]. In addition, HVDC conductors cause power loss because of their resistances, for example the copper conducting wires have a resistance  $0.02\Omega/\text{Km}$  under an operating temperature of  $90\text{ C}^0$  [123]. This loss can be reduced by increasing the diameter of the conductor, but this would be costly. The power losses in VSC HVDC transmission systems increase with transmission distance and power rating. Power losses decrease with increasing voltage level of VSC HVDC transmission systems. For example, the power losses in VSC HVDC transmission represent 6.5 % of the power being delivered (5% converter stations and 1.5% HVDC cables) for a 1200MW rated 345kV transmission line of approximately

40km [124]. In the future, the further development of HVDC transmission systems could be achieved by enhancing the materials they are made of in order to meet the increasing demand for power. One key issue is that it will be necessary to discover new materials with lower resistance, particularly for making wires, in order to reduce power loss in the transmission system.

### **3.9. Using DC HTS cable for the UK Round 3 Offshore wind Farms**

DC HTS cables have the potential to overcome the limitation of conventional HVDC transmission systems. They provide several advantages over conventional VSC HVDC transmission systems. These advantages are outlined below.

#### **3.9.1. Reduced power losses and increased power transfer capability**

Currently, VSC based HVDC technology is available at a voltage of 150 kV and it could be suitable for UK Round 3 offshore wind farm projects. To be used in high power (600 MW) transmission with HVDC cables, these voltage levels result in relatively high currents. Transmitting with high current over long distances with HVDC will result in considerable real losses. DC HTS cables will eliminate this limitation by delivering high levels of current (up to 100 times more than conventional cables) with zero electrical resistive loss over long distances[76]. This means, the DC HTS cable itself has no  $I^2R$  losses as HTS have zero resistance to DC currents. Losses in a DC HTS cable system will be related to the conversion losses of the AC/DC terminals and the losses of the required cryogenic cooling system. For a 1600km, 5GW line, this is approximately 0.7% for refrigeration losses or 0.35% for a 10GW line over the same distance [76].

### **3.9.2. The cost of off/onshore substations and transmission systems**

DC HTS cables can be used to transmit a large amount of power over long distances without power losses. DC HTS cables can be designed to carry a very high continuous power capacity of 20 GW at relatively low voltage [76]. This will eliminate the need to install transformers in offshore substations to raise the voltage level for connection to the HVDC transmission system, and has the potential to decrease the cost of UK Round 3 offshore substations. Moreover, the lower voltages will reduce the cost of inverters in the future. The low voltage inverter can be implemented only for DC HTS cables and not with HVDC cables because of the resistance.

When DC HTS cables are implemented, there are no reactive power losses, thus there is no need for reactive compensation equipment [125]. In addition, and because DC HTS cable can transmit a higher power level than that of HVDC the number of submarine cables for high power transmission will be reduced [76].

### **3.9.3. Voltage stability for transmission systems**

The voltage level at the connection point for all offshore wind turbines is 30kV. The DC HTS cables can be connected with 30kV to transmit high power over long distances to onshore substations. Since the voltage drop in DC HTS cables is negligible, voltage control will not be necessary with DC HTS transmission systems. DC HTS cable can enhance voltage stability in transmission systems because it has very low impedance. This will also provide opportunities to apply multi-terminal connections because the voltage levels will be relatively low (30kV) [125],[92].

### **3.10. The challenges of using DC HTS Technology for UK Round 3 offshore wind farms.**

#### **3.10.1. Cryogenics systems**

DC HTS technology needs a cooling system (cryogenics) to be installed every 25km in order to cool the cable. As a result, transmitting power for hundreds of miles requires several cooling stations to be installed for maintaining the cable in its superconductor state [76].

#### **3.10.2. A high fault current in DC HTS cables**

The fault current in DC HTS cables is significantly increased because the DC HTS cables have very low impedance and can be operated at a low voltage level. The fault current in DC HTS cables arises from two components. The first component will be a travelling wave caused by the discharge of the HTS cable capacitance. The second component will be driven by the voltage source on the AC side of the rectifier as shown in equation 15 [88].

$$I_d = \frac{V_{dc}}{Z_c} \quad (15)$$

Where  $I_d$  = discharge current,  $V_{dc}$  = dc voltage of the cable,

Surge impedance ( $Z_c$ ) of the cable, and L and C are the inductive and capacitive per meter of HTS cable as shown in equation 16.

$$Z_c = \sqrt{\frac{L}{C}} \quad (16)$$

#### **3.10.3. HTS materials are brittle**

Superconductor materials are brittle; therefore this will be a serious limitation, especially when the DC HTS cable is considered as a submarine cable [126].

### **3.11. A Comparison of the power loss of VSC HVDC and VSC HTS transmission systems used as transportation systems for UK Round 3 offshore wind farms**

This research required a case study in order to show the positive impact of applying DC HTS cables with VSC technologies to address the challenges which would be faced by conventional VSC HVDC transmission systems. Thus, the UK Round 3 offshore farm case seems to be a suitable case to study because a large amount of power (GW) needs to be delivered over hundreds of miles which would result in high real power losses and high capital costs when conventional DC technologies are considered. At the moment, the longest HTS cable in the world is 6km, however, the progress of increasing the length of HTS cables is currently being undertaken and it is expected to reach hundreds of miles in the near future [43]. Subsequently, this study investigates how DC HTS cables (when HTS cables are able to run for hundreds of miles) can help to overcome issues which exist when using VSC HVDC technologies with the UK Round 3 offshore wind farm case.

This investigation provides insights into the development of UK Round 3 offshore wind farms in the UK. There are nine zones of offshore farms which plan to be operational in 2020 [14] in the North Sea (about 100km off the east coast of England). The largest zone of Round 3 offshore wind farms is called the Dogger Bank offshore farm. The Dogger Bank zone will consist of eight offshore wind farms: H1, H2, H3, H4, H5, I1, I2 and J. This chapter investigates one of these offshore farms, which is the H3 zone. The H3 offshore farm will consist of 165 turbines, each turbine having a capacity of 7.5 MW (Clipper Wind Britannia). This means that the maximum power produced from the H3 offshore farm will be

1237.5 MW and this will need to be delivered over a distance of 273 km. Currently, the Dogger Bank offshore farm is still in the development stage, and should be finished by the end of 2014[14]. Figure 14 shows the Round 3 Dogger Bank wind offshore farm in the United Kingdom [15]. Table 8 gives a description of the Dogger Bank offshore farms.

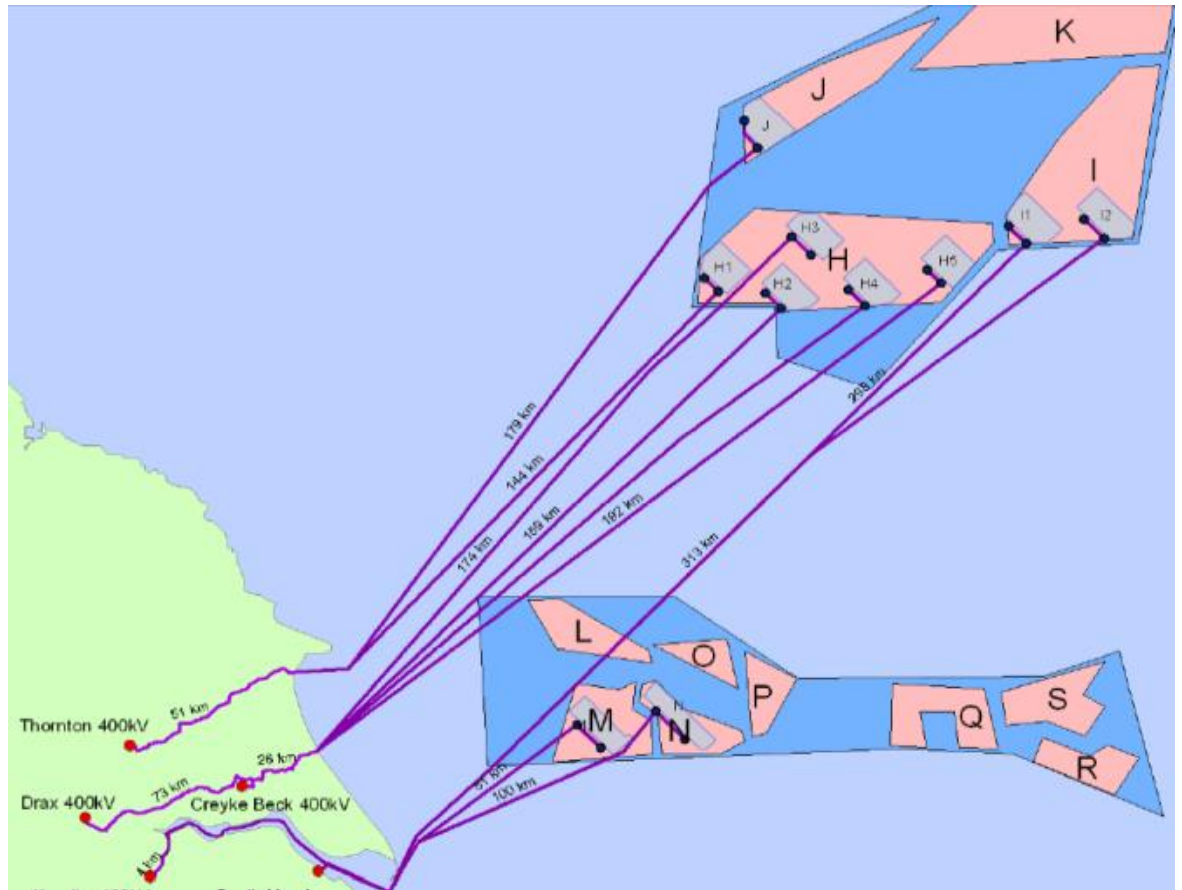

Figure 14: The UK Round 3 Dogger Bank wind offshore farms in the United Kingdom [15]



Table 8 : The Dogger Bank offshore wind farms [15].

| Dogger Bank offshore | Power capacity (MW) | Number of wind turbines |
|----------------------|---------------------|-------------------------|
| H1                   | 1237.5              | 165×7.5MW               |
| H2                   | 1237.5              | 165×7.5MW               |
| H3                   | 1237.5              | 165×7.5MW               |
| H4                   | 1237.5              | 165×7.5MW               |
| H5                   | 1237.5              | 165×7.5MW               |
| I1                   | 1240                | 248×5MW                 |
| I2                   | 1240                | 248×5MW                 |
| J                    | 1240                | 248×5MW                 |

### 3.12. VSC HVDC and VSC DC HTS models

#### 3.12.1. VSC based on HVDC IPSA model

The first step in the investigation was to build a model of a VSC based HVDC transmission system. The model was developed using IPSA software using the real parameters of each component of the network which are taken from [15],[86]. The HVDC network consists of six transformers, two generators and 273km of HVDC submarine cables. The total power loss is investigated by delivering maximum and minimum output power which will be generated from the future UK H3 offshore wind farm case. In the VSC HVDC model, the power losses increased as the amount of power delivered increased. Delivering higher power and more current through DC lines results in raising real power losses in DC lines [74],[127].

The power losses could be reduced in the VSC HVDC model by raising the voltage operating level to higher than 275kV. Nevertheless, this leads to an

increase in the capital cost of converter substations. Moreover, VSC technology is using IGBTs which are technically challenged to deliver a large amount of power at a higher voltage when they are connected in serial [72]. However, it would be easier to deliver a large amount of power at a lower voltage by connecting VSC in parallel (by increasing current), but again this would result in increased power losses in DC cables and lines [73]. Therefore, in this case study, a reasonable operating voltage level, which was suggesting in [15], has been used considering all issues which have been mentioned above. Figure 15 shows the sample IPSA model HVDC transmission system for the H3 offshore wind farm.

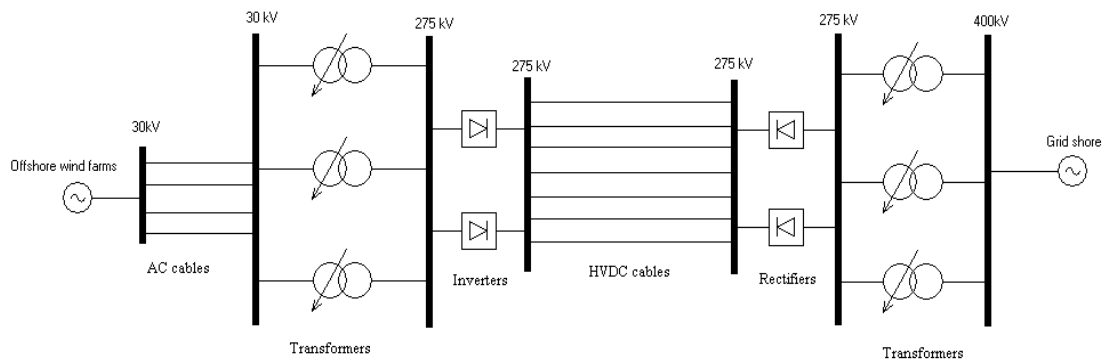

Figure 15: IPSA model HVDC transmission systems for H3 offshore wind farm.

### 3.12.2. VSC based on DC HTS IPSA model

The major benefit gained from using DC HTS cables is the ability to deliver a large amount of power over a long distance at lower voltage. The parameters of DC HTS cables are taken from [128]. This results in reducing the cost of off/onshore converter substations because the VSC cost can be reduced by reducing the operational voltage. Two DC superconductor cables operated at a lower voltage rating 100kV than the HVDC cables. The same investigation has been achieved with the VSC DC HTS model to see how much the power losses

can be reduced by using these technologies. However, the real power losses are reduced significantly when 100kV DC HTS cables are used. Real power losses in relatively low-voltage DC HTS transmission systems were up to 80% less than those in conventional high-voltage DC transmission systems. The parameters for 100 kV HTS cables are adopted from[86] .

Using 100kV DC HTS cables with VSC technologies could be help to reduce the cost of conversion substations as operating voltage levels are lower than the operating voltage levels in the conventional VSC HVDC model (275kV). Therefore, connecting VSC converters in parallel to reduce the capital cost of conversion substations and power losses in DC transmission systems can be achieved using DC HTS cables based on VSC technologies in the future. Figure 16 shows the sample IPSA model of a DC superconductor system.

Both of these models used two ABB converters, which are SVC light. The maximum power of a bipolar VSC light is 1200MW and  $\pm 320$ kV with submarine cables [129]. The transformers used in the offshore substation are three phase two winding converter transformers. Those used in the onshore substations are single phase three winding converter transformers. These transformers are operated as OLTCTs in case a voltage drop occurs in the transmission system. The voltage rating and specifications for HVDC submarine cables were different from those of the DC superconductor submarine cables. Both models require 23 AC cables to meet the peak power (1.2375GW) to flow (0.0567 MVA for each AC 30kV cable) from Dogger Bank offshore wind farm to the offshore substation. The addition of one further cable leads to a n-1 redundancy. Thus in the event of one cable failure, the remaining cables may still deliver peak power. In HVDC transmission systems, 6 submarine cables can deliver the peak power of the offshore wind

farms but 7 submarine cables are modelled to make a n-1 redundancy system. In DC HTS cables, one HTS submarine cables can carry the peak power but again two HTS cables have been modelled to make a n-1 redundancy system.

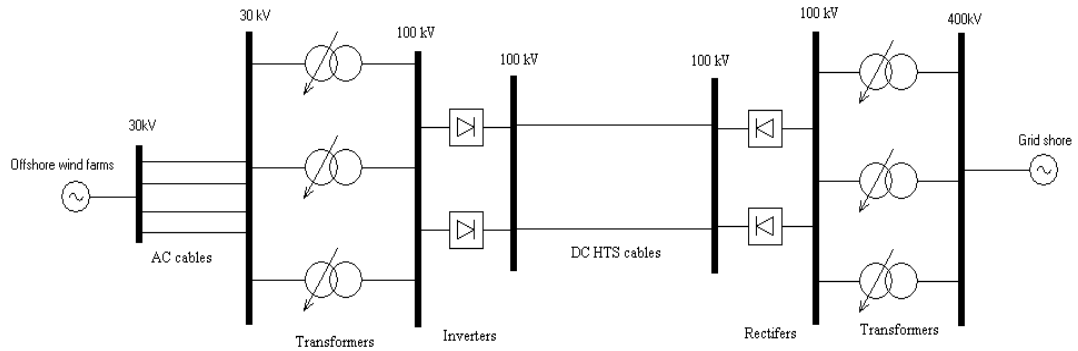

Figure 16: IPSA model of DC superconductor transmission systems for the H3 offshore wind farm.

### 3.12.3. Evaluation of the power losses of VSC HVDC and VSC DC HTS IPSA models

When the offshore wind farms produce their maximum power output of 1237.5MW, the real power loss caused by the conventional 275kV HVDC transmission system which includes HVDC cables was 21.7MW and the reactive power loss was 38.2MVar. However under the same conditions but using a 100kV DC superconductor transmission system including DC HTS cables, the overall real power loss was 4.1MW and the reactive power loss was 38.2MVar. The calculation of the power losses for the VSC HVDC and VSC DC HTS systems was performed with different power ratings for the H3 offshore wind farms: 618.8MW and 309.4MW. The results in terms of power loss for these models are indicated in figure 17 where the reactive power losses in the VSC HVDC and VSC DC HTS models were the same. This occurred because the VSC HVDC and DC superconductor transmission systems do not produce reactive

power losses and therefore the reactive losses came from the off/onshore substations e.g. from the transformers and converters.

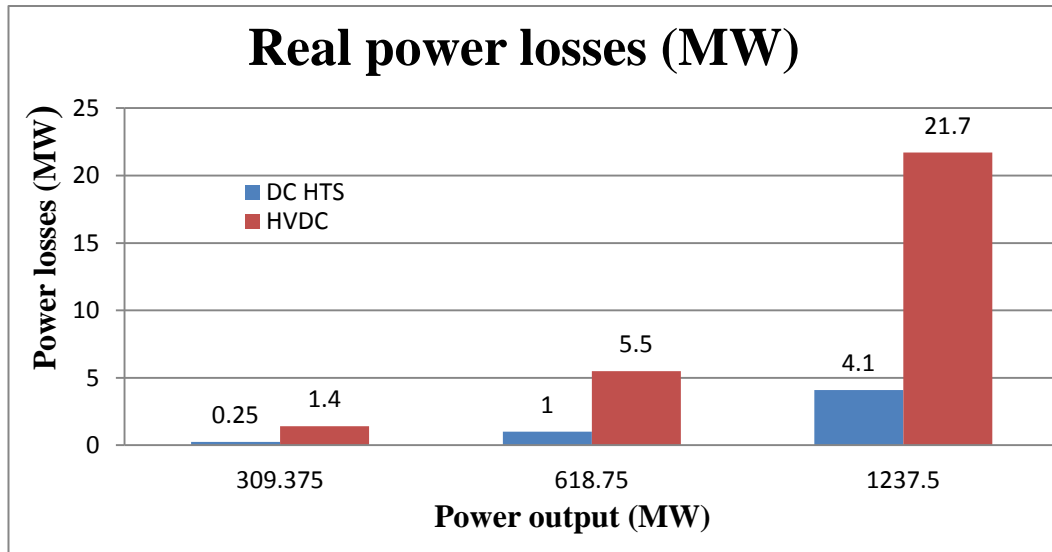

Figure 17 : The real power losses in the DC superconductor transmission systems versus the real power losses in DC HVDC transmission system.

### 3.13. The comparative cost HVDC and DC superconductor transmission systems

The evaluation of the cost of the VSC based on HVDC and VSC based on DC HTS transmission systems is essential and requires the evaluation of the cost of the three major components: converters in offshore/onshore substations, the cables and cryogenic systems. These components are the same for both the VSC HVDC and VSC DC HTS systems. The valves in the converter station consist of individual power components arranged in series or parallel in order to meet the station's voltage-current specifications [130] . This means that a higher voltage rating leads to an increase in the number of power components in the station. This results in an increase in the cost of the converter stations. Due to the fact that VSC based on DC HTS cables operate at a lower voltage 100kV than VSC HVDC

systems, a smaller number of power components can be used for the converter on/offshore substations and this leads to a decrease in the cost of the converter stations when DC HTS technology is used. Moreover, the number of submarine cables required decreases when DC HTS cables are used because of their high power capability rating. At this time, the exact reduction in the cost which can be achieved using DC HTS technology is unknown, but the results of previous academic studies which have compared the cost of HVDC and DC HTS cables can be used as a framework [81]. The valve in a VSC converter represents 20% of the total cost of the station, and the converter's transformers and AC filters represent 16% and 10% of the total cost respectively [81]. The cost of a VSC station is \$160/kVA and if the DC HTS technology can make a 50% reduction in the amount of equipment required, then the cost of the VSC based DC HTS can be reduced to \$125/kVA [81]. The cost of DC HTS cables is still higher than that of HVDC cables, but for application over long distances (>1000 miles), the cost of HVDC cables will be higher than that of DC HTS cables because the cost of the resistive losses from the HVDC cables will exceed the costs of cryogenic losses associated with the DC HTS cables. This indicates that the amount of power that can be delivered, and the distance it can be transmitted are increased as the VSC HTS technology becomes more efficient.

### **3.14. Summary**

The future impact of HTS technology on DC transmission systems has been investigated with the use of network models. The power losses in relatively low-voltage DC HTS transmission systems were up to 80% less than those in conventional HVDC cables. Moreover, DC HTS technologies can operate at a low voltage (100kV) while transmitting a large amount of power in GW. This can

reduce the cost of transmission systems by reducing the number of DC cables and converter stations. They have the potential to operate at 30kV, therefore; they can reduce the challenges of VSC technologies and reduce the cost of offshore substations. Although DC HTS have a number of attractive attributes, further research is required prior to the technology being adopted by the electricity industry. These challenges include the cost and complexity associated with the cryogenic cooling systems they require. In the future, DC HTS transmission systems may become a viable option for the transmission of power from offshore wind farms.

Further research needs to be conducted on the application of DC cables to future offshore wind farms in order to find the optimum voltage for applying DC HTS cables in order to lower power losses, capital cost and risk when compared to HVDC transmission networks. However, there are many AC HTS cables and HTS transformers in distribution networks that have been installed and operate successfully, but there are very few DC HTS cables that have operated in real grids, consequently further research should be focused on applying AC HTS cables and HTS transformers to AC distribution networks. The following chapter will address the concept of applying AC HTS cables and HTS transformers to distribution networks.

## 4. Reactive Power Sharing in Superconducting Power Systems

This chapter addresses the possibility of sharing the provision of reactive power between distributed generators and the broader distribution network when HTS cables and transformers are used. Implementing conventional techniques for accomplishing reactive power sharing in conventional distribution power systems relies upon voltage magnitude changes to function correctly; however, in superconductor distribution power systems, the voltage magnitude changes are relatively much smaller because the impedance of superconductor distribution power systems is much lower. Therefore, the possibility of sharing reactive power in superconductor distribution power systems needs to be investigated to find out to what extent conventional techniques can be applied to HTS power systems to achieve reactive power sharing in the absence of relatively large voltage changes.

Growing challenges relating to voltage control, power losses and demand increases in urban areas supplied by MV distribution networks highlight the need to accurately and flexibly share reactive power provision between large power stations and multiple distributed generators [4]. Consequently, voltage control can be achieved in conventional distribution networks by controlling the reactive power provision or consumption from local distributed generators (DGs) [131]. In many cases utility companies prefer this approach to alternatives such as capacitor banks which add additional cost and can only supply, not absorb, reactive power and only in discrete quantities [8],[131].

In addition, there has been increased interest in integrating more DGs into electrical distribution networks during the last decade[4]. Advantages of



integrating more DGs into distribution networks include enhanced reactive power support, reduced power losses, and improved voltage profiles [5],[6]. However, operating multiple DGs in the distribution network can increase problems of stability, power flow management, and voltage regulation [7]. These issues are associated with increases and variability in the reactive power transported by distribution networks. Consequently controlling reactive power flow is of great interest in distribution networks and being able to accurately and effectively share reactive power between DGs is also desirable [132]. The following sections describe in more detail the drivers for effective reactive power sharing.

- **Supplying heavy variable loads with a poor power factor**

In cases where a section of distribution network is heavily loaded and at a non-unity lagging power factor, supplying the reactive power exclusively from the grid can cause voltage control problems and lead to increased losses. In such cases it may be possible to include local DGs in the provision of reactive power. The reactive power demand is likely to be variable and each of the DGs will have technical and economic limits to the extent to which they can participate in reactive power provision, therefore an effective means of sharing the reactive power burden between generators becomes necessary [6],[132],[133].

- **Localised Voltage Control**

Although the X/R ratio of distribution networks is lower than for transmission networks it is often still effective to control voltages in distribution networks through reactive power control. Ideally this should be undertaken as close to the source of voltage deviations as possible. DGs will increasingly be located in

disparate locations. Therefore in many cases it is more desirable to call upon DGs for reactive power response than the upstream grid.

- **Generation economics**

In a network with a variety of DGs the costs of reactive power provision will inevitably vary. The ability to flexibly share the reactive power burden between a portfolio of distributed generation schemes allows for the economically optimum mix of contributions to be called upon.

- **Low carbon considerations**

When the mix of DGs includes fossil fuel and non-fossil energy sources the ability to control sharing of reactive power provision also allows for the lowest carbon mix to be called upon. Generators have an MVA limit and if they are being used to provide reactive power it can reduce the extent to which they can concurrently export real power. Hence exporting or importing reactive power using a generator represents a sacrifice in real power export capability. Therefore at a time when the wind resource is plentiful it may be attractive to run the wind generators at maximum output and use fossil fuel generation to take up the majority of the reactive power burden. This situation could be reversed in times of reduced wind speeds. In addition, market prices and different incentives between fossil and non-fossil sources can influence the sharing of reactive power choices [5],[134],[135].

#### **4.1. Sharing in conventional distribution networks**

Several studies propose the sharing of reactive power between DGs in conventional distribution networks. A solution to the problem of operating heavy

loads with non-unity lagging power factors in distribution networks by sharing reactive power between two DGs is proposed in [132]. It shows that the DGs can be used in the network to reduce the reactive power losses if they already exist in the network. One DG is used to supply to where the reactive power is needed in the network to avoid delivering reactive power through the distribution network [132]. The sharing of reactive power between these distributed generators is accomplished by an automatic power factor regulator (APFR), which allows a heavy load to be supplied while simultaneously maintaining the voltage within the required limits. In [133], the sharing of reactive power between DGs is proposed to supply heavy loads and to keep the voltage within network limits. The sharing of reactive power between generators in this case is achieved through the generator AVRs to control the output of reactive power from each generator. Occasionally, on-load tap-changing transformers must be used in conjunction with DGs when the DGs are unable to maintain the voltage within the saturation limits. In [132] and [133], on-load tap-changing transformers are used to maintain the voltage within required limits when one of the DGs goes off-line for some reason such as the occurrence of a fault or when the DGs supply heavy loads by sharing reactive power between them. Thus, on-load tap-changing transformers need to be used in order to help the DGs to maintain the voltage within limits. A further use for on-load tap-changing transformers is in conventional distribution networks when the sharing of reactive power needs to be balanced equally between DGs [133].

As the demands placed on electrical distribution networks increases through the adoption of electric vehicles and heat pumps, the need for lower loss, higher power density distribution networks becomes more acute. One technology option

capable of meeting these challenges involves the use of high temperature superconductors.

In many cases the very small voltage drops associated with HTS power systems are extremely valuable as they simplify the voltage control problem significantly. However, conventional reactive power sharing techniques rely upon voltage magnitude changes to function correctly. This raises the question, addressed in this chapter, namely to what extent can conventional techniques be applied to HTS power systems to achieve reactive power sharing in the absence of relatively large voltage changes? Voltage drops in distribution networks can be determined by the application of equation 17.

$$\Delta V = \frac{(RP + XQ)}{V} + j \frac{(XP - RQ)}{V} \quad (17)$$

Where, the  $\Delta V$  is the voltage change in the system from sending to receiving end busbars; P and Q are the active and reactive power loads, R and X are resistance and reactance respectively and V is the sending end voltage.

The voltage drops in superconductor distribution networks are much lower than the voltage drops that occur in conventional distribution networks. For example, the voltage at busbar B for the 33 kV superconductor distribution network which is shown in figure 18 is 0.999 pu while the voltage at busbar B for the 33 kV conventional distribution network is 0.986 pu for the same conditions (load =3MVA at 0.9 lagging power factor). Therefore, the voltage changes in the superconductor distribution network from busbar A to busbar B is 0.001 pu while the voltage changes in the conventional distribution network from busbar A to

busbar B is 0.014. Based on results, the voltage change in distribution network when HTS equipment is used is approximately 10 times less than the voltage change in conventional distribution networks.

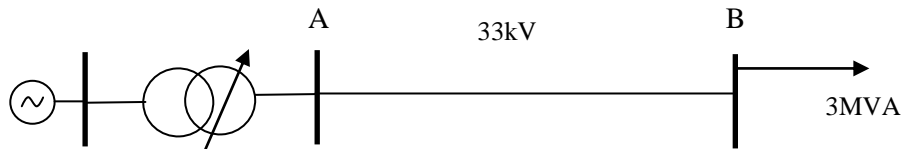

Figure 18: Example of voltage changes in conventional and superconductor distribution networks

The X/R ratio in HTS cables is different to the X/R ratio in conventional overhead lines and conventional cables, table 9 defines the electrical characteristics of MV conventional and superconductor cables and shows that the X/R ratio of HTS cables is smaller than that of conventional cables. Hence, the voltage drop in a superconductor network would be very small, and might have a different direction from conventional networks. For this reason the X/R ratio of HTS cables has different response to RP and XQ. This chapter addresses the possibility of sharing reactive power between distributed generators in MV conventional distribution networks and also in MV distribution networks containing HTS transformers and HTS cables. Also, power losses and the annual energy cost in conventional networks are compared with those of networks containing HTS transformers and HTS cables.

Table 9: Electrical characteristics of MV UGC HTS cable and MV UGC conventional cables [34].

| A Comparison of Power Transmission Technologies           |                    |                   |                     |
|-----------------------------------------------------------|--------------------|-------------------|---------------------|
| Technology                                                | Resistance (mΩ/km) | Reactance (mΩ/km) | Capacitance (nF/km) |
| UGC HTS Nexans                                            | 0                  | 11.4              | 2880.6              |
| UGC Conventional<br>NA2XS2Y RM/35<br>1×630mm <sup>2</sup> | 12                 | 17.1              | 3635                |

#### 4.2. Types of control system for distribution networks to share reactive power between distributed generators

Two types of control systems can be applied in distribution networks: the autonomous control method and the remote control method. In this chapter, an autonomous control system is used because of the possibility of reducing costs compared with remote controlled systems, as the latter require additional devices to link the power system equipment with the control room [132].

#### 4.3. Case study

An investigation of the opportunity for sharing reactive power between DGs in a conventional distribution network is achieved by using the case study shown in Figure 19. The main reason of developing a different network for this chapter is to investigate how much power loss can be reduced using HTS assets with an 11kV distribution network. Moreover, this investigation needs to have a network that has two DGs to achieve control reactive power in superconductor and conventional distribution networks. The case study is adopted from [136]. The network consists of two conventional transformers to step the voltage down from 33 kV to 11 kV. There are two feeders in the network, each of which has one DG

at the remote end operating at 11 kV. The maximum power that can be provided from either distributed generator is 9 MVA. One feeder consists of 12 km of 300 mm<sup>2</sup> feeder cable and the other feeder consists of 3 km of 300 mm<sup>2</sup> feeder cable. Matlab Simulink is used to model this network. The parameters of conventional cables and conventional transformers used are obtained from [136],[137] and are shown in detail in the Appendix 1 .

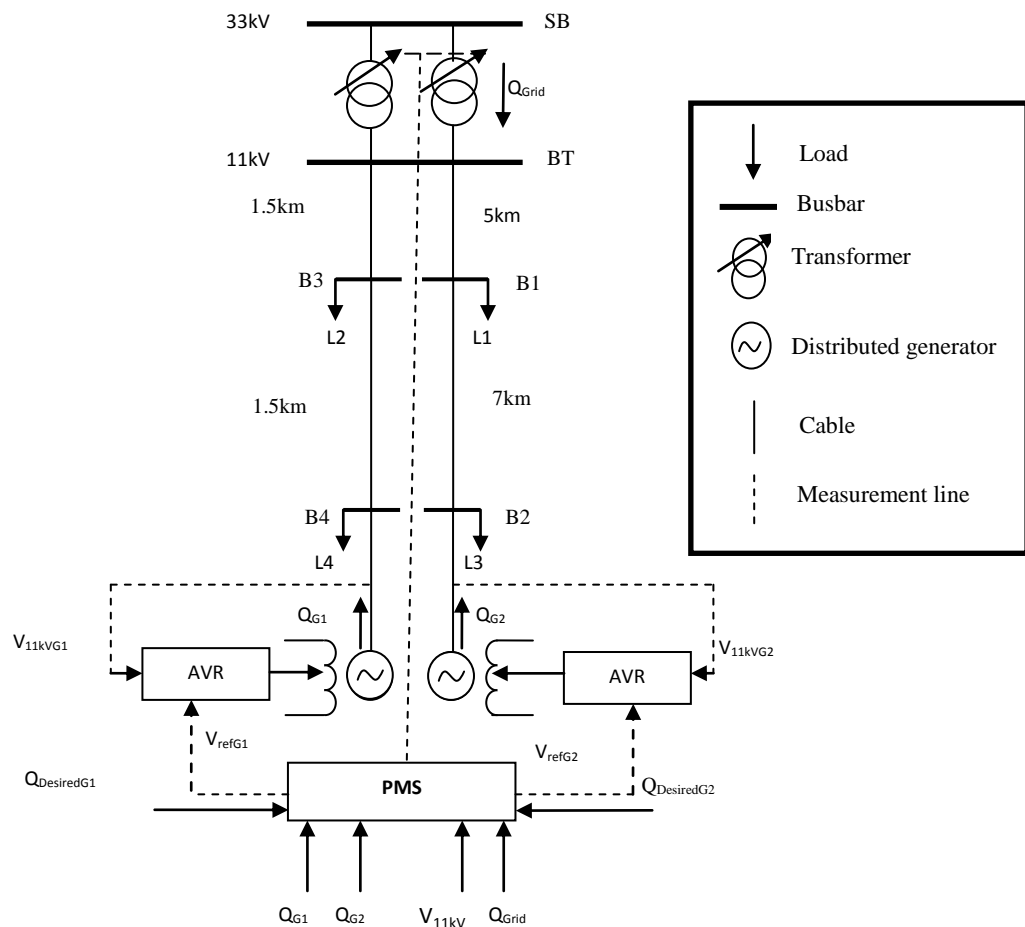

Figure 19: Configuration of the case study system

#### **4.4. Controller requirement for sharing reactive power between two generators**

Control of reactive power sharing between two DGs is required to manage the reactive power output from each generator. Generator AVRs can control the excitation of the generator. When the generator is overexcited, the synchronous generator provides reactive power to the network and when underexcited the generator absorbs reactive power. This means that it is necessary to build a generator AVR model in order to achieve control of reactive power sharing between DGs. This study is primarily focused on sharing reactive power between DGs; therefore, the governor is assumed to be fixed at 5 MW at a fixed frequency of 50 Hz. Moreover, the control system of the on-load tap-changing-transformer needs to be modelled to keep the voltage within the required limits of the 11 kV distribution network when the distributed generators are not able to maintain the voltage in the required range.

#### **4.5. Generator AVR model**

As previously described, the main function of a synchronous generator excitation system is to regulate the voltage of the generator terminal voltage. The excitation of the generator can be adjusted using an AVR which will operate continuously to adjust the excitation of the generator, and in turn, impact the terminal voltage and reactive power exchanged with the network. The function of the generator AVR in this study is to keep the terminal voltage at 11 kV equal to the reference value ( $V_{ref}$ ). Therefore, the reactive power output from the generator is changed in line with the terminal voltage of 11 kV. The approach of the generator AVR model was taken from [8],



which was modelled on IEEE type 2 [138]. Figure 20 shows the AVR modelled on IEEE type 2, all the parameters of the model are given in Appendix 1.

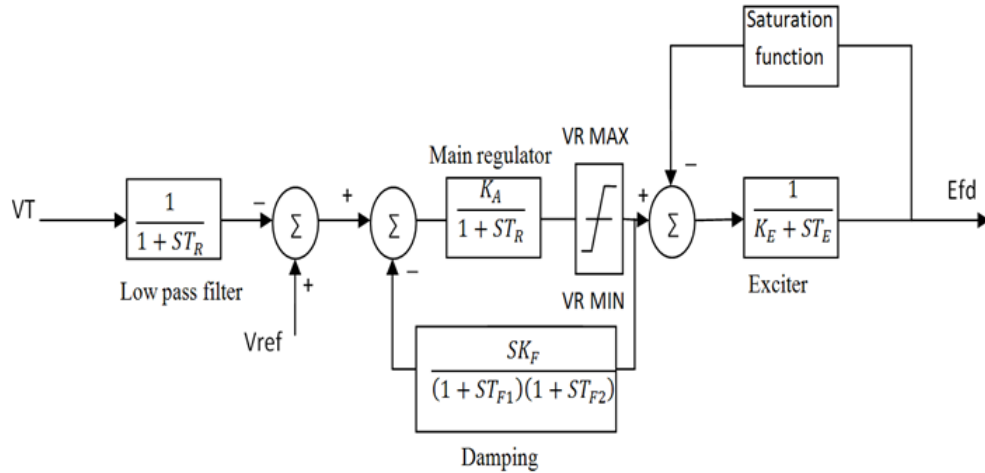

Figure 20: The generator AVR model, IEEE type

#### 4.6. Modelling of the on load-tap changer transformer control systems

Modelling of the transformers with tap-changing facilities is achieved in Simulink by modelling the ideal transformer to control the tap ratio ( $a$ ) of the 33 kV/11 kV transformer. The ideal transformer does not have any impedance; therefore, it is not the cause of any power losses in the network. The model for the control systems is used to automatically change the transformer taps under load in order to keep the voltage in the secondary side of the transformer within the required limit. This process can be achieved using a line drop compensator (LDC).

The function of the line drop compensator ( $R_c+jX_c$ ) is to control the voltage at a remote point stand-alone feeder. The magnitude of the resulting compensated voltage ( $V_c$ ) which is fed to the AVR, is given by equation 18.

$$V_c = V_t + (R_c + jX_c) \cdot I_t \quad (18)$$

Where  $V_t$  is the measured phasor voltage at the transformer secondary side, and  $I_t$  is the current through the transformer.

The measured voltage ( $V_{BT}$ ) is compared with the reference voltage ( $V_{ref}$ ) to obtain the error as shown in equation 19.

$$\text{Error} = V_{ref} - V_{BT} \quad (19)$$

Two transformers are combined into one transformer by calculating their impedances in parallel. The OLTC of the transformer control system model is shown in Figure 21.

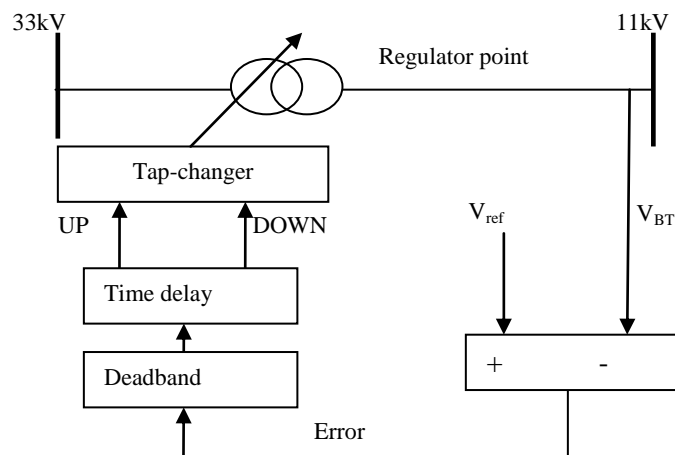

Figure 21: On-Load Tap-Changing Transformer model

The tap-changing steps move in positive and negative directions to adjust the secondary voltage of the transformer. The change of tap position is carried out in discrete steps with each beginning at 1.67% of the normal ratio. The control system will be operated if the error is greater than a deadband of 1% tolerance band (in which case the tap position moves down one step) or less than a of -1 tolerance band % (in which case the tap position moves up one step) in order to maintain the voltage in the

distribution network within  $\pm 0.06$  pu. The control system of the OLTC of the transformer begins to work after 30 seconds and once the tap position is set, it is held there for 10 seconds before the next change of tap position can take place [8]. The number of steps that can be made is  $\pm 20$  steps[136].

#### **4.7. Objectives of the power management systems (PMS)**

The PMS is used in this study to control the voltage/reactive power in distribution networks based on generator AVRs and the control system of OLTC of the transformer. The PMS controls the reactive power of the generators by setting reference values for the generator AVRs. Moreover, it controls the tap position of the transformer during the operation of the system. The PMS objectives are to maintain the voltage of the 11 kV busbars to within  $\pm 0.06$  pu of their normal values and to facilitate the sharing of reactive power between the generators.

When the utilities ask PMS to provide a certain amount of reactive power ( $Q_{\text{Desired}}$ ) at certain time from each DG, then the PMS measures reactive power output from each DG ( $Q_{G1}$  and  $Q_{G2}$ ) and the voltage ( $V_{11kV}$ ) in the busbar transformer (BT) as shown in figure 19. After that, a control loop, which applies proportional and integral (IP) algorithms, is used in the PMS to provide voltage references ( $V_{\text{ref1}}$  and  $V_{\text{ref2}}$ ) for such generator AVRs to supply reactive power desired for each DG (more details introduced in section 4.8). At the same time, PMS also measures the voltage ( $V_{11kV}$ ) in the BT to see if the voltage value (pu) is still within required limits. If the measured voltage in BT ( $V_{11kV}$ ) is out of the deadband limits range ( $\pm 1\%$ ) then the PMS would ask the tap transformer to move up or down to keep voltage ( $\pm 0.06$  pu) within limits (more details introduces in section 4.6 and

4.8). The PMS maintains the same process to provide a desired reactive power from each DG and to keep voltage levels within the limits in the network.

#### 4.8. Control strategy

The control strategy of this study is based on the possibility of sharing reactive power between the generators and the grid. Sharing reactive power between the generators and the grid is carried out using an autonomous control system based on PMS. The control strategy is based on supplying a percentage of reactive power needs from each generator. This gives supply companies the opportunity to supply the optimum percentage of the reactive power to a distribution network driven by, for example, market prices or incentives in 11 kV distribution networks which exist in urban areas. As described above, the generator AVRs adjust the excitation of the generator to control the terminal voltage and reactive power output at 11 kV. The PMS provides reference values to the generator AVRs to manage the desired reactive power from each generator. The AVRs of all generators have a constant settling time of 2–3 seconds. The tap change starts operating after 30 seconds to avoid unnecessary use of the tap changer. Figure 22 shows the reactive power output control of 11 kV generators.

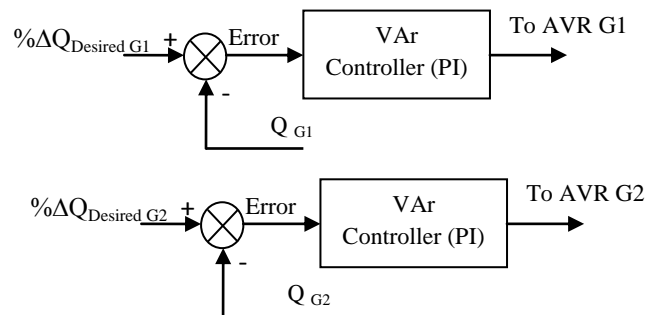

Figure 22: The reactive power output control of 11 kV generators

A control loop would be required in the PMS to supply the percentage of reactive power desired from each generator. The percentage of reactive power desired is compared with the value of reactive power measured from the 11 kV network and the reactive power output controller applies proportional and integral algorithms (PI) to eliminate any steady state error. PI controllers provide the  $V_{\text{refs}}$  to the generator AVRs based on changes in the percentage of reactive power desired for each generator.

Figure 23 shows that the PMS controller determines the tap position of the transformer during operations. It also requires a second control loop to manage tap changes during operations. The control loop starts to work after 30 seconds of operation [8]. The tap changing control is only enabled when the AVR response has reached the steady state. The measured voltage is obtained from the secondary side of the 11 kV transformers, and is compared with  $V_{\text{ref}}$ . The error obtained is processed through the control system to evaluate whether or not it is within the required limits. Thereafter, the decision is taken for the tap position to move in a positive or negative direction or to stay in the same position.

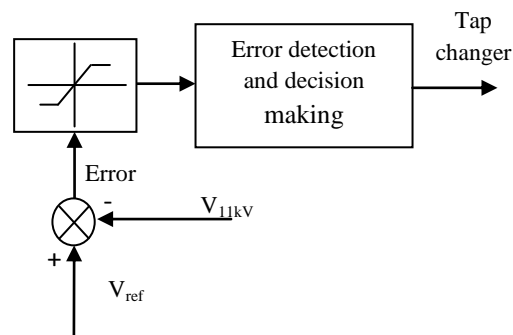

Figure 23: The control system for OLTC of transformer

#### **4.9. Modelling an 11 kV superconductor distribution network**

The major benefit gained from using superconductor equipment in distribution networks is exhibited by very low impedances which can eliminate problems with voltage regulators and reduce power losses that occur in traditional distribution networks. HTS cables and HTS transformers have been used to model superconductor distribution networks whereby all conventional 11 kV cables and transformers have been replaced by 11 kV HTS cables and HTS transformers. The specifications and benefits of using HTS cables and HTS transformers in 11 kV distribution networks are presented next.

##### **4.9.1. 11kV HTS cables**

HTS cables are used to model the superconductor distribution network designed for operation at medium voltage. MV HTS cable will be used in the “AmpaCity” project by Nexans in 2013 which will deliver power of up to 40 MVA between two substations in Essen, Germany, using a cable system of approximately 1 km with one joint. The cost of MV HTS cable may still be higher than that of conventional ones, but it helps to reduce costs in a number of parts of the distribution system. This is because HTS cables can deliver five times more power than conventional cables at a lower operational voltage thus eliminating the need to install transformer substations to raise the voltage to increase power delivery[34].The resistance of 11 kV HTS cables is selected based on [92] and [37] and the reactance of HTS cables is taken from [34]. All parameters of the 11 kV HTS cables are detailed in the Appendix 1.

The first generation of HTS wires (Bi-1222) is used to produce MV HTS cables[139]. They are composed of cold dielectric concentric phases which are suitable for operation in MV systems. The cable has a return channel for the cooling medium. The main advantage of this design is that the amount of superconductor material is significantly reduced, which reduces the cost of the HTS cable. Figure 24 shows a schematic of a MV HTS cable [34].

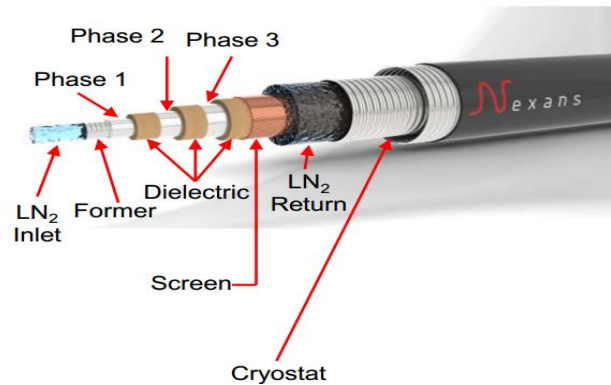

Figure 24: AmpaCity Project – Three Phases 40 MVA, MV cable concept [140]

#### 4.9.2. Calculation of the impedance of MV HTS cable

The resistance of a MV HTS cable is represented by AC losses instead of joule losses which are associated with conventional cables [141],[142]. Reactance ( $X_t$ ) and susceptance ( $B_t$ ) have the same physical origin in the cable as in conventional cables. Equations 20, 21 and 22, are used to find the parameters shown [143].

$$X_t = (L \times \omega) \times l \quad (20)$$

$$B_t = (C \times \omega) \times l \quad (21)$$

$$R_{SC} = \frac{1}{N \times A} \times \rho_{wire} \quad (22)$$

The expressions for finding the value of the inductance and the capacitance are 23 and 24 respectively

$$L = \frac{\mu_0}{2\pi} \times \ln\left(\frac{r_s}{r_2}\right) \quad (23)$$

$$C = \frac{2\pi \times \epsilon_0 \times \epsilon_r}{\ln\left(\frac{r_s}{r_2}\right)} \quad (24)$$

Where L and C are the equivalent inductance and capacitance of the cable, and  $\omega$  is the angular frequency of the network.  $\mu_0$  is the magnetic constant,  $r_s$  is the radius of the cable shield,  $r_2$  is the outer radius of the cable phase,  $\epsilon_0$  is the electric constant,  $\epsilon_r$  is the relative permittivity of the dielectric,  $R_{sc}$  is cable resistance, A is the wire cross sectional area, N is the number of wires,  $\rho_{\text{wire}}$  is the wire resistivity and  $l$  is the length of the cable.

#### 4.9.3. HTS transformer

The development of the HTS transformer achieved so far is based on the rating of MVA [48],[49]. In this study, the HTS transformer is required to step down the voltage from 33 kV to 11 kV. From the literature review, currently no HTS 33kV/11kV transformers exist; therefore, the closest HTS transformer, rated at 22.9/6.9kV, was selected for use in this study. Based on [52],[144],[145],[146], the impedance of the HTS 33kV/11kV transformer is obtained and converted to a per unit value based on the transformer 30MVA base rating. The parameters of the HTS transformer are shown in detail in the Appendix 1.

#### 4.10. Testing the performance of the PMS controller

The performance of the PMS controllers is tested by instructing each generator to give a certain percentage of reactive power at a certain time.



Moreover, changes in the variable loads during operation are modelled. This will improve the ability of the PMS to supervise the generator AVRs and transformer tap to provide the percentage of reactive power desired at a certain time and to keep the voltage within the required limit of  $\pm 6\%$  in the distribution network.

Figure 25 shows how the loads (at a power factor of 0.6 lagging) in the distribution network change with time and Table 10 shows the test regime used for the superconductor and conventional distribution networks. The reason for setting the loads at a 0.6 lagging power factor is to prove that PMS controllers can still supervise the generator AVRs and transformer tap correctly to provide the optimal percentage (%) (Which is given by utilities) of reactive power desired at a certain time and to keep the voltage within the required limit of  $\pm 6\%$  in the distribution network, even in a worst case condition.

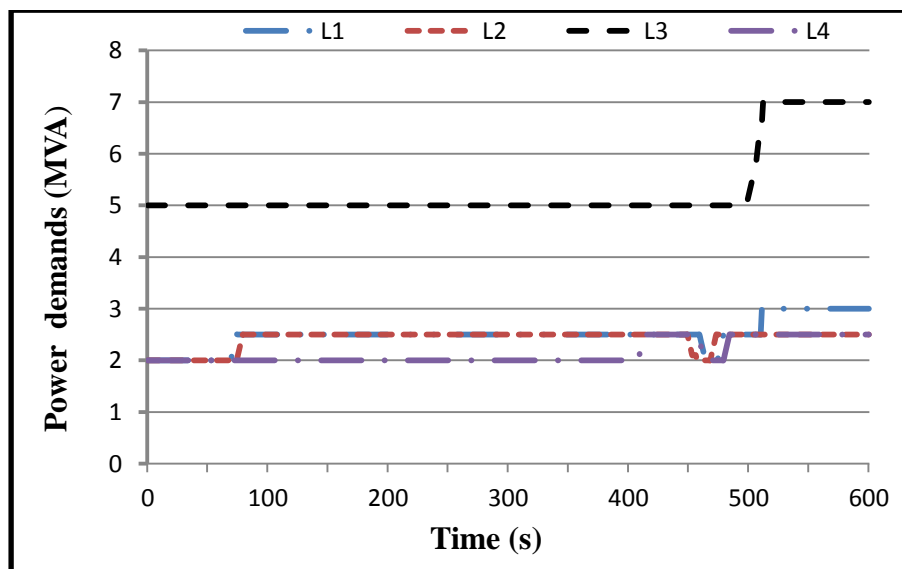

Figure 25: Variable loads in the case study distribution network

Table 10: Test Regime for the PMS Controller (% age share of reactive power supply).

| Time(s) | %Q <sub>Grid</sub> | %Q <sub>G1</sub> | %Q <sub>G2</sub> |
|---------|--------------------|------------------|------------------|
| 0       | 0%                 | 50%              | 50%              |
| 40      | 45%                | 25%              | 30%              |
| 100     | 45%                | 35%              | 20%              |
| 180     | 50%                | 15%              | 35%              |
| 240     | 68%                | 7%               | 25%              |
| 300     | 80%                | 5%               | 15%              |
| 350     | 93%                | 2%               | 5%               |
| 400     | 100%               | 0%               | 0%               |

Table 11: variable loads in the case study distribution network

| Time(s) | L1(MVA) | L2(MVA) | L3(MVA) | L4(MVA) |
|---------|---------|---------|---------|---------|
| 0       | 2       | 2       | 5       | 2       |
| 80      | 2.5     | 2.5     | 5       | 2       |
| 420     | 2.5     | 2.5     | 5       | 2.5     |
| 460     | 2       | 2       | 5       | 2       |
| 490     | 2.5     | 2.5     | 5       | 2.5     |
| 540     | 3       | 2.5     | 5       | 2.5     |

Table 11 shows how loads are changed in the network. The locations of such loads are shown in figure 19, based on the time the loads are changed. For example, the peak demand is 13MVA at 540s while the demand is 12MVA at 80s.

#### 4.11. Results of simulation without PMS controller

In order to provide a baseline case for the study it is necessary to evaluate the performance of the conventional and superconducting networks without

a PMS controller. This will identify if the controller of the transformer tap changer with a fixed  $V_{\text{refs}}$  for the generator AVRs can maintain the voltage levels within required limits in this 11kV distribution network.

The main target of implementing PMS controllers with superconductor and conventional distribution networks is the ability of the PMS to supervise the generator AVRs and transformer tap to provide the optimal percentage of reactive power desired at a certain time and to keep the voltage within the required limit of  $\pm 6\%$  in the distribution network. Consequently, the first step of this investigation is to see if the transformer tap can keep voltage within limits when  $V_{\text{refs}}$  for each generator AVR is fixed at 0.94 pu in both the 11 kV conventional and superconductor distribution networks. Based on results indicated in figure 26, the voltage levels in busbars B1, B2, B3 and B4 in both cases are changed as loads (L1, L2, L3 and L4) in the network change. The locations of loads and busbars in the network are shown in figure 19. Figure 25 (a and b) shows the results of voltage changes in the 11 kV conventional and superconductor distribution networks without operating the PMS controller and with a fixed  $V_{\text{refs}}$  for the generator AVRs (0.94pu). Moreover, figure 26 (a) shows that for the 11kV conventional network the tap transformer stepped up once at 30(s) to maintain the voltage level within limits in the network because voltage level dropped in B2 when total demand was 11MVA. However, the voltage level also dropped below the limit of - 6% at B2 when total demand was 12.5MVA at 500s as shown in figure 26(a). The tap transformer could not maintain the voltage level within the required limit in B2 at 500s for the 11kV conventional distribution network. This is because the control of the transformer tap changer is only

operated if the error is greater or less than a deadband  $\pm 1\%$  (more explanation about OLTC transformer is given in section 4.6). In the 11kV superconductor network the transformer tap was not required even at 500s, when total demand was 12.5MVA, to operate because all of the voltage deviations were within the deadband limits ( $\pm 1\%$ ) As shown in figure 26(b).

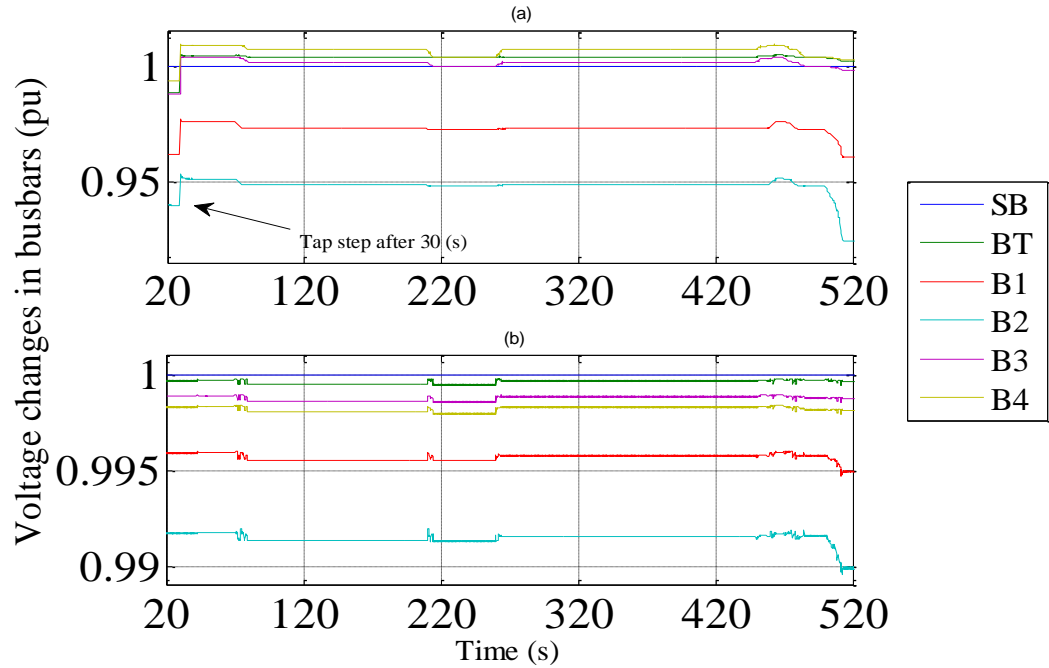

Figure 26: Results of voltage changes without PMS controllers in Simulations a) Conventional Distribution Network, b) superconductor distribution network ( $V_{ref} 0.94$ pu)

Another test was carried out on the 11 kV conventional and superconductor distribution networks with the generator AVRs at fixed  $V_{ref}$  but with different values. The  $V_{ref}$  for DG1 AVR was 1.002 pu while the  $V_{ref}$  for DG2 AVR was 1.005 pu. Figure 26 (a and b) shows the results of reactive power output from the grid and DGs in 11 kV superconductor and conventional distribution networks. Based on the results in Figure 26, the amount of reactive power which has been provided by each DG in 11 kV conventional distribution networks was different from the amount of

reactive power which produced from DGs in the 11 kV superconductor distribution network. This was because the voltage changes in the 11 kV superconductor distribution network were very small in comparison to the voltage changes in the 11 kV conventional distribution network. Different voltage changes in such networks have a major influence on the amount of reactive power which can be produced from DGs. for example in figure 27. Here the voltage changes at 300s occurred at B2 which was connected to DG2 in the 11kV conventional distribution network and was approximately 10 times (as shown in figure 26 a and b) higher than the voltage change at B2 which was connected to DG2 in the 11kV superconductor distribution network under the same condition. Therefore, the DG2 in the 11kV conventional distribution network provided higher reactive power (6.5MVARs) at 300s, when total demand was 12MVA (as shown in figure 25 and table 11) while DG2 in the 11kV superconductor distribution network provided lower reactive power (4.5MVARs) to the network for the same condition.

These results emphasised the necessity of implementing PMS controllers to supervise the generator AVRs and transformer tap to provide the optimal percentage of reactive power desired at a certain time and to keep the voltage within the required limit of  $\pm 6\%$  in each distribution network.

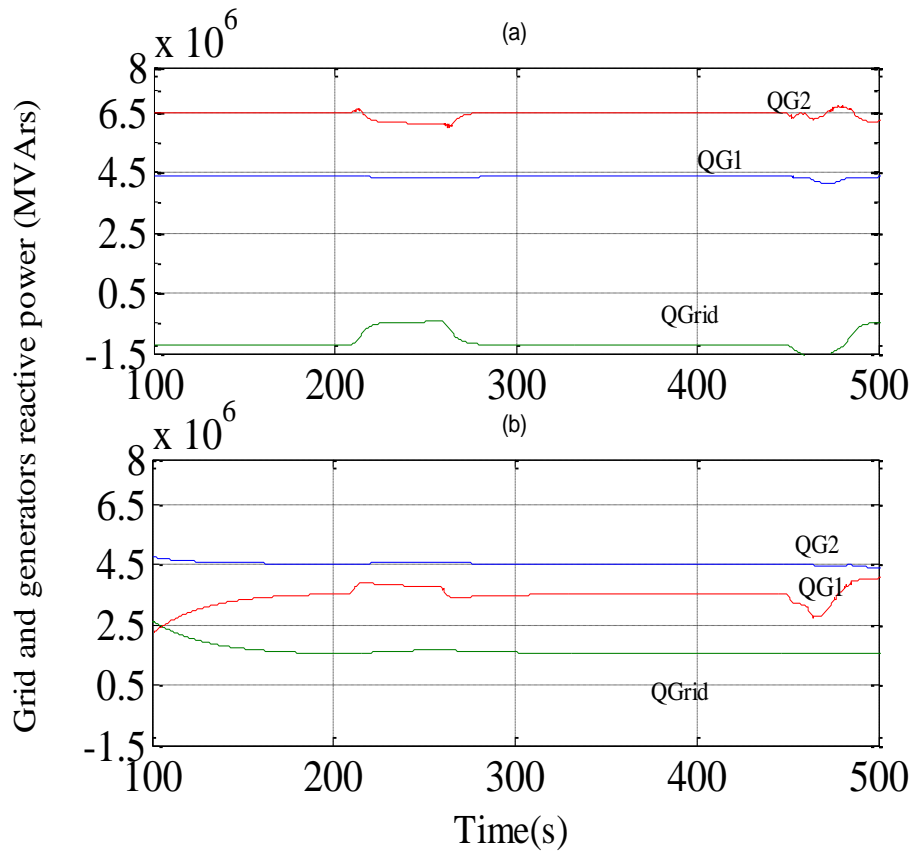

Figure 27: Results of Q (MVAr) without PMS controllers from grid and DGs in Simulations a) Conventional Distribution Network, b) superconductor distribution network ( $V_{ref}$  1.005 and 1.002 pu)

#### 4.12. Results of the simulation with PMS controller

The results of the simulation for the conventional distribution network and the distribution network that contains HTS cables and an HTS transformer is presented here. The comparison between these distribution networks is addressed in three parts; sharing of reactive power between the DGs based on the percentage of reactive power desired from each, real power from the generators and grid voltage changes in busbars.

The PMS proved able to control reactive power between the DGs and the grid according to the percentage of reactive power desired from each generator (Figure 28 a and b). The tap transformer stepped up at 540s when

total demand was 13MVA in the 11kV conventional distribution network which raised the amount of reactive power from grid side ( $Q_{grid}$ ) for 1 second, then it got back to a normal rating while the rise of reactive power rating did not occur in the 11kV superconductor network because the tap transformer had not stepped up under the same condition as shown figure 28 a and b. However, control of reactive power in the both the conventional and superconductor distribution network is achieved by using PMS controllers with the same gain values for PI controllers.

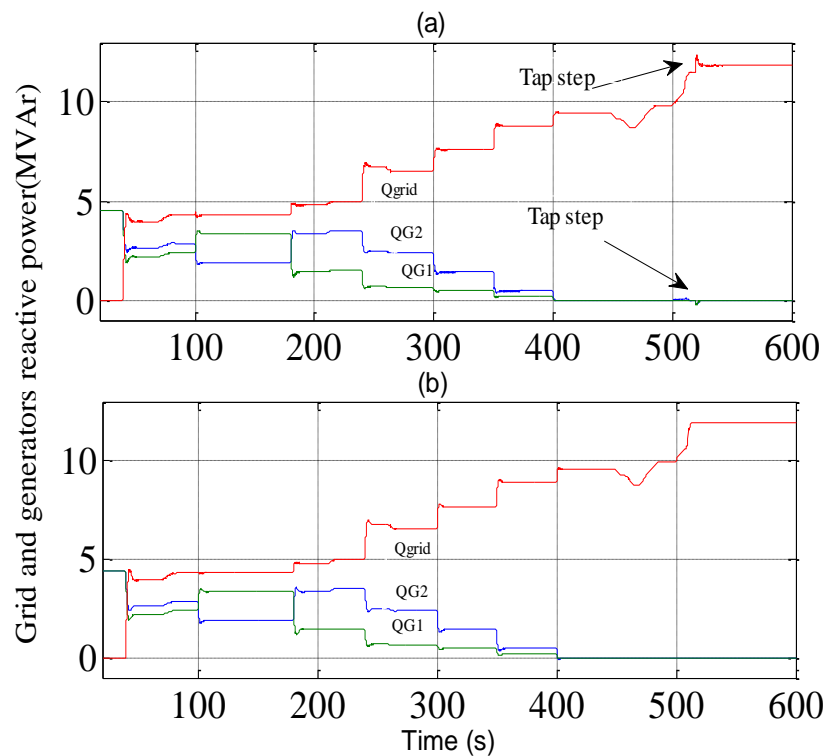

Figure 28 : Results of Q (MVARs) with PMS controllers from grid and DGs in Simulations a) Conventional Distribution Network, b) superconductor distribution network

The real power from each generator is fixed because the governor is assumed to be fixed at 5 MW, while the real power of the grid changes according to the changing power MVA demand in the network (due to variable loads) and changing the percentage of reactive power supplied by each generator. Figure 29 a and b show the real power from the generators

and the grid in both the conventional and superconductor distribution network. Again, the tap transformer stepped up at 540s when total demand was 13MVA in the 11kV conventional distribution network which raised the amount of real power from the grid ( $Q_{grid}$ ) for 1 second, and then it got back to a normal rating, while the rise of the real power rating did not occur in the 11kV superconductor network because the tap transformer did not step up under the same condition as shown figure 29 a and b.

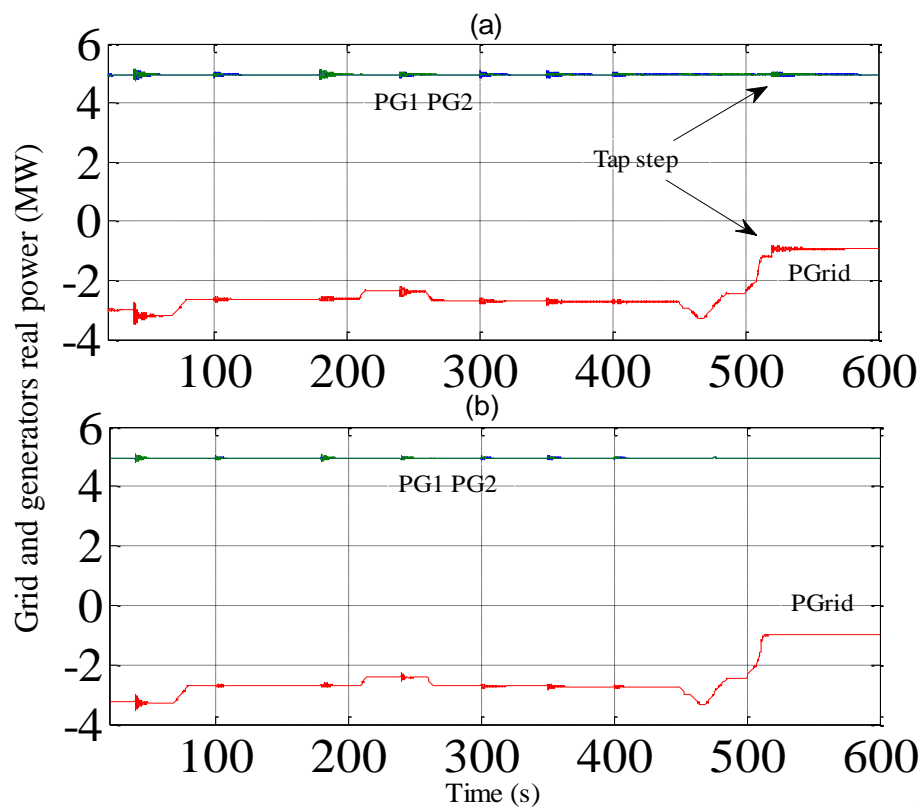

Figure 29: Results of P (MW) with PMS controllers from grid and DGs in Simulations a) conventional distribution network. b) Superconductor distribution network

There are significant differences between the voltage changes in both networks when HTS cables and transformer are used. In the conventional distribution network, the transformer tap had to move in a positive direction to bring the voltage back within the required limit of  $\pm 6\%$  in B2 when the assumed percentage of reactive power desired from the DGs was zero as



shown in figure 30 a and b . In a similar test regime for the superconductor distribution network the transformer taps did not need to take any action because very little voltage drop occurred in the superconductor distribution network ,which is 10 times less than the voltage changes that occurred in the conventional one .. This is because the HTS cables and the HTS transformer have very low impedance. Thus one benefit gained when the superconductor equipment is used in distribution networks is that voltage regulation problems are eliminated because there will be no significant voltage drop in the network. This negates the need for the OLTC transformer in distribution networks which, in turn, reduces infrastructure costs in the distribution network. Figure 30 (a and b) shows voltage changes in both the conventional and superconductor distribution networks.

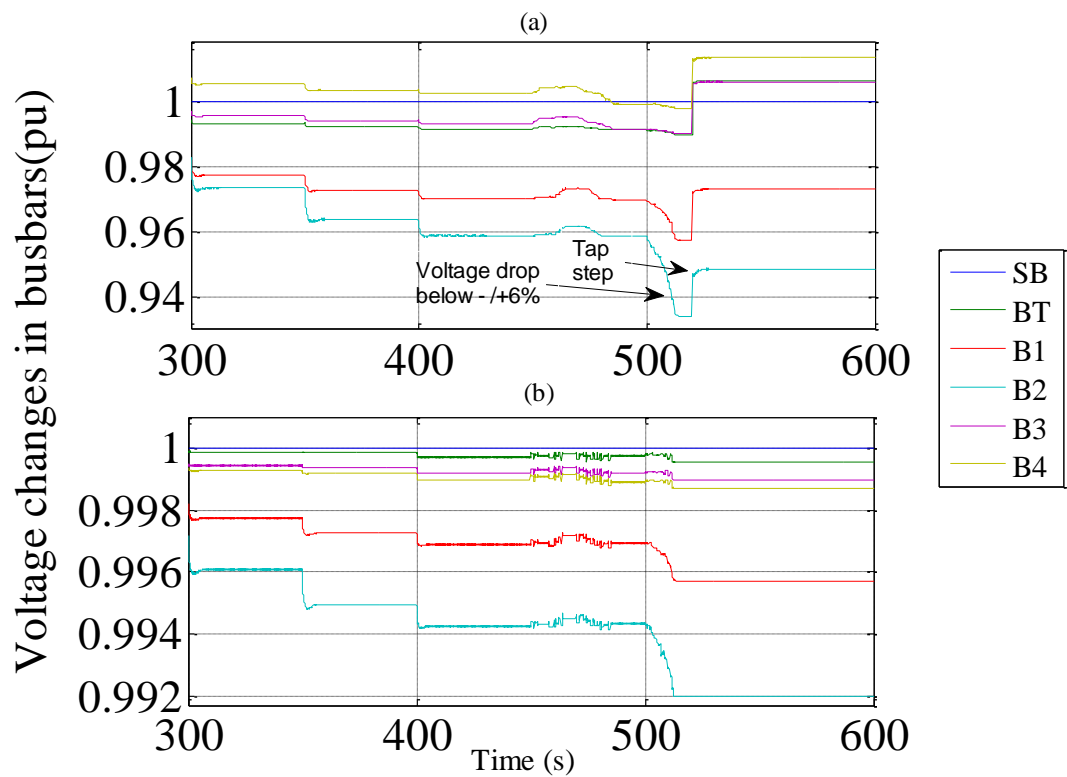

Figure 30: Results of voltage changes with PMS controllers in Simulations a) Conventional Distribution Network. b) Superconductor distribution network

A new design could be conducted for a generator AVR for superconductor distribution networks. In this case, the inputs of generator AVRs may consist of reactive power output measured from a generator ( $Q_{DG}$ ) and the reactive power desired ( $Q_{desired}$ ) (rather to used  $V_{desired}$  and terminal voltage measurement for generator) to control reactive power output for a generator. This leads to an elimination of the extra control loop which exists in the conventional generator AVR to control the reactive power output from such generators.

#### **4.13. Analysis of amplitude and duration of oscillation in superconductor and conventional networks**

The comparison of oscillations between the superconductor and conventional distribution networks is presented in order to evaluate the maximum oscillation that occurs in these networks. The maximum oscillation in the conventional distribution network had amplitude of 0.19 MW with duration of 20(s) seconds while the maximum oscillation in the superconductor distribution network had amplitude of 0.09 MW and duration of 10 seconds. The difference occurs because the superconductor distribution network has significantly smaller impedances than the conventional distribution network, which reduces oscillations when the AVR forces field current changes in the generator. Oscillations in distribution systems can be expression by equation 25.

$$P_s = \frac{dP}{d\delta} = \frac{E' \cdot V}{Z} \cdot \cos \delta \quad (25)$$

Where  $P_S$  or  $\frac{dP}{d\delta}$  is the synchronizing power coefficient,  $\delta$  is the power angle curve, serial impedance between generator and infinite busbar,  $E'$  is the generator constant voltage and  $V$  is the voltage for infinite busbars.

From equation 25, the oscillations in generator are related to serial impedance ( $Z$ ) between generator and infinite busbar. If the  $Z$  is high then the oscillations in system are higher and vice versa. Therefore, the oscillations that occurred in a superconductor network were smaller than those that occurred in a conventional network because a superconductor network has a smaller impedance. This reduces the need to use a power stabilizer system (PSS) with an AVR to reduce oscillation in the system. Thus, in this study, the PSS does not need to be installed but in a larger distribution network it will be required because the impedance in the network will become bigger. Figure 31 (a and b) shows the biggest oscillation occurring in the conventional and superconductor distribution networks.

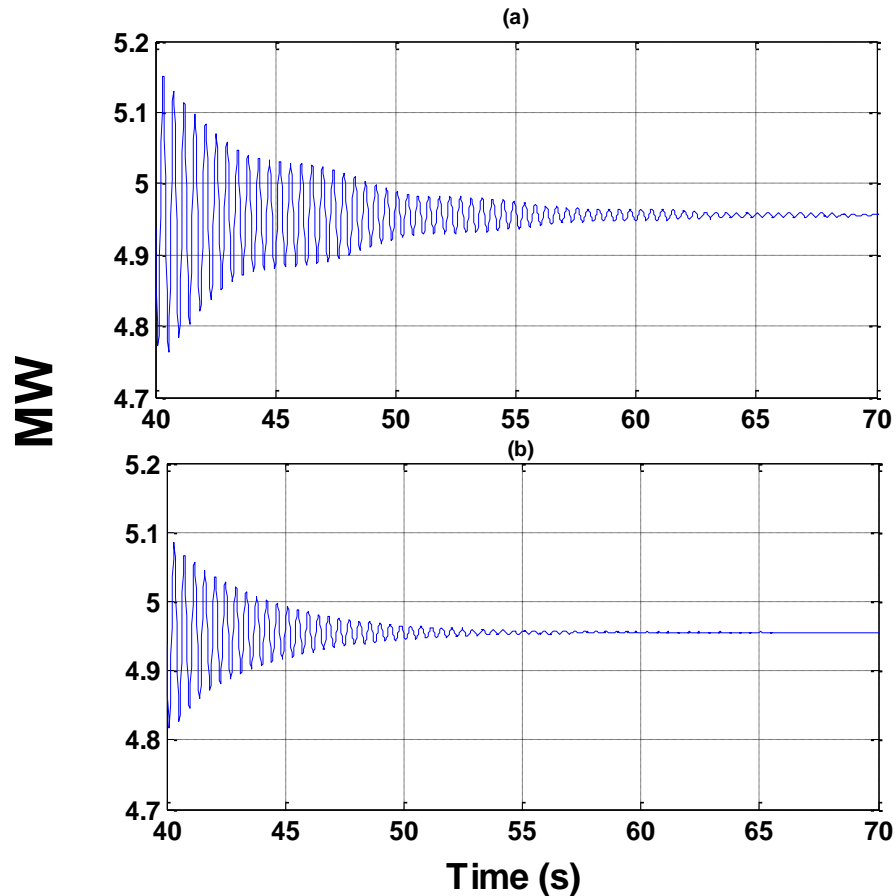

Figure 31: The largest oscillation occurring in the conventional and superconductor distribution networks

#### 4.14. Power loss evaluation in superconductor and conventional distribution networks

Power losses in the conventional and superconductor distribution networks were evaluated according to the test regime. The maximum real and reactive power losses in the conventional network were 0.54 MW and 0.64 MVar while those in the superconducting network were 0.00075 MW and 0.056 MVar. However, HTS cable needs to operate at a temperature of no more than 77 K (the boiling point of liquid nitrogen), to provide a very low impedance. Therefore, it is necessary to use a refrigeration system to keep the temperature of HTS cable and HTS transformer at the required

temperature. Power consumption associated with refrigeration systems are considered as real power losses in HTS cables and transformers and these losses are added to the real power losses of HTS cables and transformers to quantify the total real power losses in the superconductor distribution network.

The power consumption associated with a refrigeration system that maintains HTS cables at 77 K is approximately 2 to 5 kW/km while the power consumption of a 30MVA HTS transformer operating at 75-77 K is 6kW[46],[147],[148],[149],[150]. The power consumption of refrigeration systems varies with the temperature of HTS cables. The temperature of the cable increases with the loading current from 0 to the peak load of the current that can be delivered by the cable. For example, in [35], power consumption by the refrigeration systems for HTS cable is 4 kW at 77 K and 2.8 kW at 66 K. In this study, the power requirement of each refrigeration unit is assumed as 5 kW/ km, the length of the HTS cables is 15 km, and therefore the power consumption by all refrigeration units is 0.075 MW. Also, the power consumption of the refrigeration system for the 30MVA HTS transformer is 6kW. As a result in this study, the total real power losses in the superconductor network including refrigeration systems is 0.082 MW while the total real power in a conventional network is 0.54 MW.

#### **4.15. Comparison of energy losses and cost of energy losses in superconductor and conventional distribution networks**

The energy losses in conventional and superconductor distribution networks were calculated in order to compare the energy losses between these

networks. The energy losses in this case study for the 11kV conventional network is 646.7 MWh in a year. In a superconductor network, the energy losses a year consist of energy losses at HTS cables and transformers over a year, plus the energy consumption by refrigeration systems of HTS cables and transformers over a year. For that reason, the energy consumption attributable to the refrigeration systems associated with HTS transformers and HTS cables is 516.8 MWh per year while the energy losses in the superconductor network are 1.4 MWh per year. Consequently, the total energy losses in the superconductor network is approximately 518.2 MWh compared to 646.7 MWh per a year in the conventional network.

From [151], the cost of energy losses is £60/MWh. Thus, energy losses in a conventional network cost £38.8 k / year whereas energy losses in a network comprising HTS cables and an HTS transformer cost £ 31.1 k / year. Using HTS cables and transformers in an 11 kV distribution network can reduce the cost of energy losses by £7 k / year, leading to a cost saving of £ 210k over a thirty year period when compared to a conventional network. All calculations are shown in Appendix 2.

When HTS cables and transformers are considered in distribution networks, the accuracy of voltage measurements is very low. For this reason, conventional equipment such as the AVR must be sufficiently accurate to detect the voltage ratio error in an 11 kV network because the error will be smaller than that occurring in a conventional network. Digital AVRs represent one solution that could be used to detect a small voltage ratio error when HTS cables and transformers are used.

#### **4.16. Summary**

In this chapter, control of the relative contributions of power feeders between two distributed generators connected to separate 11 kV conventional distribution network was presented based on an autonomous method using a PMS. The results confirm the ability of a PMS controller to share reactive power between generators not just equally but based on a specified percentage of reactive power from each generator and the grid contribution. Moreover, it was shown that the PMS can be used with an 11 kV distribution network, when HTS cables and a HTS transformer are used, to share reactive power between distribution generators. These studies also demonstrated that network case study (11kV superconductor and conventional distribution networks) cannot maintain voltage levels without implemented PMS controllers. The use of HTS cables and transformers in a distribution network provides annual energy losses to the value of £7 k and saves further costs by negating the need for some conventional equipment such as OLTC of transformers.

This study showed that conventional technologies can be used to share reactive power in superconductor distribution networks. Additionally, the voltage control devices are no longer required to be implemented in an MV superconductor distribution networks to keep voltage within the required limit. This raised a question about the amount of power that can be injected from future renewable energies such as onshore wind farms to meet future demand in urban areas before causing voltage regulator issues in the distribution network. The next chapter will be focussed on the possibility of increasing the number of future DGs in urban areas where distribution

networks exist to meet such future demand without causing any voltage regulator issues in the system and without implementing any conventional technologies to maintain voltage level within required limit.



## **5. Investigating the potential impact of superconductors in alternative distribution network designs**

Renewable energies (REs) and electrical vehicles (EVs) are seen to be part of the solution to reduce CO<sub>2</sub> emissions in the UK [152]. By 2020, the UK government proposes to have increased the electricity demand to 13.1TWh for EVs while sourcing 20% energy from REs [153],[154]. However, increasing numbers of electrical vehicle (EV) sources and heat pumps (HPs) in the future may lead to increased voltage drop issues in conventional distribution networks, and will also impact on the amount of power delivered into conventional distribution networks due to EVs and HPs charging from these networks. This will be considered as an additional power demand which may cause voltage drop issues and thermal overloads with conventional distribution networks in the future [155].

When considering targets to reduce CO<sub>2</sub> emissions and meeting future demand in conventional distribution networks in the UK, several RE sources such as wind farms need to be connected as distributed generation (DGs) to distribution networks to meet such future demand and to reduce CO<sub>2</sub> emissions. However, operating many DGs in the distribution network can increase problems of stability, power flow management, and voltage regulation[7]. There are many techniques currently implemented in distribution networks to reduce the voltage excursions such as sharing of reactive power between DGs, power factor control, capacitor placement and transformer tap change control [8]. Using these techniques with distribution

networks is targeted to maintain voltage level in 20 kV conventional distribution networks within certain levels  $\pm 6\%$  [8],[156]. However, these techniques often increase system capital and operational costs. In addition, increased delivery of power to urban areas where distribution networks exist is challenging when considering conventional power system technologies such as conductors and transformers, especially in cases where space to install new cables and transformers is scarce. The voltage change in networks can be calculated according to from equation 26.

$$\Delta V = \frac{(RP + XQ)}{V} + j \frac{(XP - RQ)}{V} \quad (26)$$

Where, the  $\Delta V$  is the voltage change in the system from sending to receiving end busbars; P and Q are the active and reactive power loads, R and X are resistance and reactance respectively and V is the sending end voltage.

A key research challenge is to discover new conductor and transformer material with significantly lower resistance in order to reduce impedance of distribution networks. Since HTS materials provide very low resistance to AC currents when cooled to the boiling point of liquid nitrogen (77 K), interest in using these materials for equipment in distribution power systems is growing rapidly [8]. HTS materials have been used in transformers and conductors to reduce the power losses ( $I^2R$  and  $I^2X$ ) and to overcome voltage control problems that are associated with conventional cables and

transformers. AC HTS cables can deliver significantly more power (3–5 times) than conventional cables and hence provide the opportunity to reduce grid congestion problems in urban areas [157]. Although implementing a conventional distribution network with HTS equipment results in AC power losses such as hysteric losses and eddy current losses, these AC losses are still much lower than those resulting from conventional power system conductors [157]. Furthermore, HTS tapes are available for use in the windings of transformers. Using HTS materials in transformers provides several benefits over conventional transformers, including higher power density, lower operating losses, fault current limiting, lower impedance, and better voltage regulation [57],[48].

This chapter investigates the impact of future demand including EVs and HPs and future RE sources on voltage profiles with existing UK MV conventional distribution networks. Moreover, the investigation will find the impact of future demand and future REs on voltage profiles with existing UK MV distribution networks which contain HTS cables and HTS transformers. Existing MV conventional power systems and those containing HTS cables and transformers are compared and conclusions drawn regarding the likely impact of HTS technologies on the capital cost and operation of future power systems.

### **5.1. Case Study Network**

First step was to model existing UK 20kV conventional distribution network using IPSA 2 Software. A different network from previous cases has been used in this chapter to investigate how much power loss can be reduced in the 20kV distribution network using HTS technologies. Moreover, onshore

wind farms are planning to connect with this practical network in the future, therefore, it would be a good investigation to show how applied HTS technologies with this network could address the challenges which would face 20kV conventional distribution networks in the future in terms of reducing voltage regulator issues. Real parameters of each component of the 20kV conventional distribution network have been used to model the network. The voltage regulator (VR) and capacitor bank (Cb) have been modelled to keep voltage in  $\pm 6\%$ . Also, transformers are modelled as on-load tap changer transformer (OLTCTs). Each transformer can carry power up to 25MVA. Tap changers have 15 steps to maintain voltage in target voltage in BT (1.02 pu). The change of the tap position is carried out in discrete steps with each beginning at 1.5% of the normal ratio. Figure 32 shows the network which has been modelled.

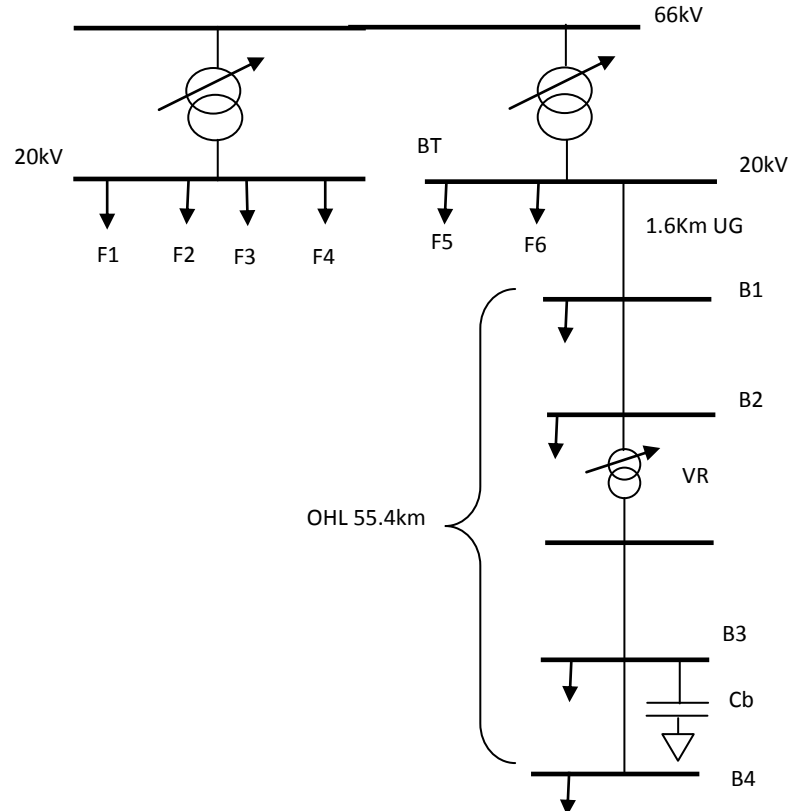

Figure 32: The existing 20kV distribution network model

## **5.2. Analysis of voltage change in 20 kV conventional and superconductor distribution network**

In this work, sensitivity analysis has been performed to determine the voltage change in conventional networks and networks containing HTS cables at the present demand. Moreover, an investigation has been done to find out the impact of onshore wind farms on voltage change in conventional networks, and one that contains HTS cables.

### **5.2.1. Peak demand**

This case investigated the voltage changes in the 20 kV conventional distribution network at early evening peak demand. Demand reaches peak value in the summer and winter seasons [158]. In the UK, June, July and August are considered the summer peak demand and December, January and February as the winter peak demand, therefore the highest demand has been taken based on these assumptions for this study to investigate the comparisons of voltage changes that occur in the 20kV superconductor and conventional distribution networks at the current peak demand, which is 31MVA in this case network study [158].

A collaboration of tap changer transformers, Cb and VR, are required to maintain voltage level within required limits in the conventional distribution network. Table 12 shows the voltage change in the 20 kV conventional distribution network at peak.

Table 12 : The voltage change in the 20 kV conventional distribution network at peak.

| Busbars      | BT (pu) | B1(pu) | B2(pu) | B3(pu) | B4(pu) |
|--------------|---------|--------|--------|--------|--------|
| Voltage (pu) | 1.020   | 1.0071 | 0.9715 | 0.9902 | 0.9575 |

In 20 kV distribution networks which contain HTS cables, the voltage change is very small compared to the voltage change which occurred in 20 kV conventional distribution network at peak because impedances of HTS cables are very low. In addition, collaboration of OLTCT, Cb and VR, are no longer needed to be implemented to keep voltage level within the required limit in the network when HTS cables are considered. This will reduce the capital cost of the network. Table 13 shows the voltage change in the 20 kV distribution networks which contains HTS cables at peak demand.

Table 13: The voltage change in the 20 kV distribution network contains HTS cables at peak demand.

| Busbars      | BT (pu) | B1(pu) | B2(pu) | B3(pu) | B4(pu) |
|--------------|---------|--------|--------|--------|--------|
| Voltage (pu) | 1.02    | 1.0199 | 1.0198 | 1.0197 | 1.0194 |

At peak demand, the VR stepped up the voltage to 1 pu between B2 and B3 and also Cb supplied 4MVAR to B3 in the 20kV conventional distribution network as shown in figure 32. Moreover, OLTCT operated to maintain the voltage level of busbar BT within the required limit  $\pm 6\%$ . Therefore, the collaboration of OLTCT, Cb and VR are necessary in the 20kV conventional distribution network to keep voltage levels within required limits as shown in table 12. The results in table 13 show that the use of

OLTCT, Cb and VR are no longer needed in the 20kV distribution network when HTS cables are considered at peak demand.

### **5.2.2. Future demand**

In this case, the voltage changes in the 20 kV conventional distribution network has been evaluated when future demand (EVs and HPs) is considered. This investigation needs to be implemented to see whether the present conventional distribution network can cope with future demand without causing any voltage drop issues. The number of transformers needs to be increased in this case to meet the rating of power delivered to the network to meet future demand as shown in figure 33. EV and HP home charging are the most common and may be considered as a 4kW constant load on the network [158]. Therefore, the power consumption of EV and HP for each customer has added to the current peak demand to obtain the future demand for this case study, which is 50MVA.

Based on these results, the voltage level in 20 kV conventional distribution network goes under the required limit (- 6%) at busbars B2 and B4 when future demand is considered. In addition, the collaboration of on-load tap changer transformers, VR and Cb, have operated in this case but they could not show that they could keep voltage level within required limit in the network. This indicates that the voltage drop issues will face the present conventional distribution network when future demand is considered. Consequently, more equipment is required to be installed in the present conventional network to maintain the voltage level within the required limit of  $\pm 6\%$  which leads to an increase in the capital cost of the network. Table

14 illustrates the voltage change in 20 kV conventional distribution network when future demand (EVs and HPs) is considered.

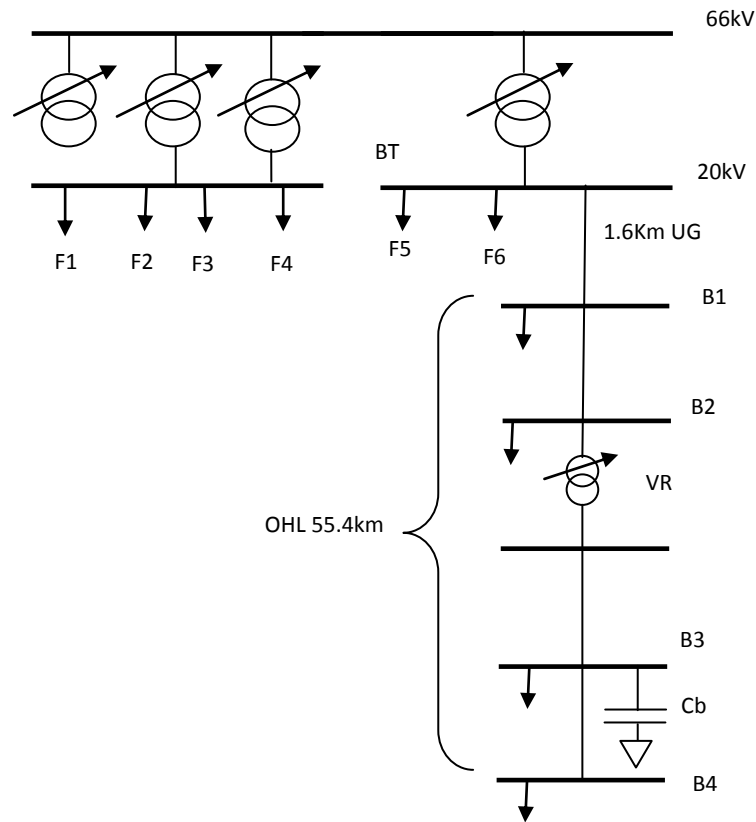

Figure 33: The conventional distribution network at future demand

Table 14: The voltage change in 20 kV conventional distribution network when future demands are considered

| Busbars      | BT (pu) | B1(pu) | B2(pu) | B3(pu) | B4(pu) |
|--------------|---------|--------|--------|--------|--------|
| Voltage (pu) | 1.02    | 0.9976 | 0.9320 | 0.9824 | 0.9266 |

In this case, the HTS transformer and HTS cables have replaced conventional cables and transformers in the 20 kV distribution network. HTS transformers have higher a MVA rating than conventional transformers. Therefore, only one HTS transformer was applied rather than three conventional transformers to cope with a rating of power needed to be



delivered in the network to meet future demand. All parameters of HTS transformers are taken from [159] and [160] and then converted per unit. The voltage level in the 20 kV superconductor distributing network is maintained within the required limit when future demand (EVs and HPs) was considered and without the need to implement OLTCT, Cb and VR, in the network. Table 15 indicates the voltage change in 20 kV superconductor distribution networks at future demand.

Moreover, some research showed that EVs would impact negatively on the low voltage conventional distribution network. In [158] and [161], the impact of EV demand on the present 11kV conventional distribution network was investigated. They showed that EV demand would cause voltage drop issues in the present 11kV distribution network in the future. Therefore, the EV interface devices may be designed to minimise or even eliminate the effects of EVs on the conventional distribution networks in the future. This leads to an increased capital cost for the conventional distribution network. However, as shown in table 15, the future demand (including EVs and HPs) would not cause any voltage drop issues in the 20kV superconductor distribution network; therefore, the additional cost for EV interface devices and conventional control assets are no longer required to be installed in the future superconductor distribution networks.

Table 15: The voltage change in 20 kV superconductor distribution network at future demand.

| Busbars      | BT (pu) | B1(pu) | B2(pu)  | B3(pu) | B4(pu) |
|--------------|---------|--------|---------|--------|--------|
| Voltage (pu) | 1.02    | 1.0199 | 1.01906 | 1.0188 | 1.0187 |

### 5.2.3. Future onshore wind farm integration at minimum demand

An investigation into the possibility of integrating future onshore wind farms with the present conventional distribution network is required to evaluate how much power can be injected by future onshore wind farms before causing voltage regulation issues in network.

In this study, onshore wind farms have connected to 20 kV conventional distribution networks (Figure 34) at unity power factor to find the maximum power that can be injected from future onshore wind farms before voltage regulator issues occur in the network. Large onshore wind farms capable of generating less than 1MW are normally connected on an 11kV network while the large onshore wind farms capable of generating above 5MW are normally connected on a 33kV network [162], therefore, the expectation of large onshore wind farms capable of generating is between 1– 5MW in a 20 kV network. Based on results in this case study network, the maximum power that can be injected from future onshore wind farms into the existing distribution network is 2.5 MW at minimum demands (6MVA). The voltage level in 20 kV conventional distribution network goes over the required limit (+ 6%) at busbar B4 when power of onshore farms is increased more than 2.5MW. Table 16 shows the maximum power can be

injected by future offshore wind with 20 kV conventional distribution network at minimum demand.

Table 16: The maximum power can be injected by future onshore wind with 20 kV conventional distribution network at minimum demand

| Busbars      | BT (pu) | B1(pu) | B2(pu) | B3(pu) | B4(pu) |
|--------------|---------|--------|--------|--------|--------|
| Voltage (pu) | 1.02    | 1.0195 | 1.094  | 1.026  | 1.06   |

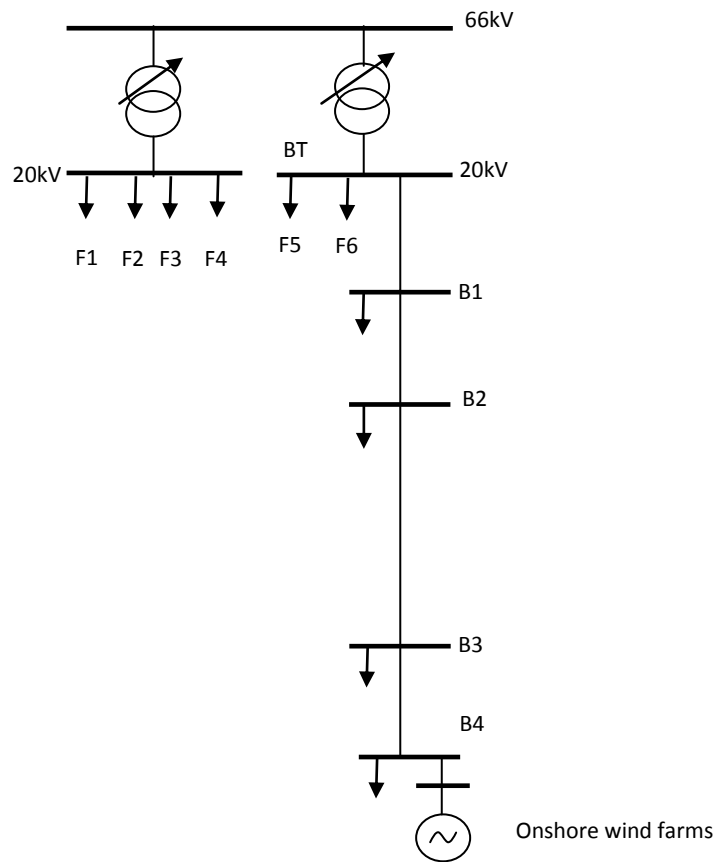

Figure 34: The onshore wind farms connect with the case study network conventional distribution networks

The same investigation has been achieved with 20kV superconductor distribution network to find out the maximum power that can be injected at minimum demand by future onshore wind farms. Table 17 indicates that the 20 kV superconductor distribution network can deliver up to 40 MW from

future onshore wind farms without causing any voltage regulator issues in the network. The reason for delivering just 40 MW from onshore wind farms was because the maximum power rating for HTS cables used in this study is 40 MVA. Table 17 shows the maximum power that can be injected by future offshore wind with a 20 kV superconductor distribution network at minimum demand.

Table 17: The maximum power that can be injected by future onshore wind with 20 kV superconductor distribution network at minimum demand

| Busbars      | BT (pu) | B1(pu) | B2(pu) | B3(pu) | B4(pu) |
|--------------|---------|--------|--------|--------|--------|
| Voltage (pu) | 1.02    | 1.0199 | 1.017  | 1.016  | 1.0146 |

The serious issue of integrating REs into the present 20kV conventional distribution network is the ability of delivering power greater than 2.5MW at minimum demand as shown in table 16. Therefore, wind energy convention control systems are required to be considered to control the output power from wind turbines to maintain the voltage level at required limits in critical demand periods. The wind energy convention control systems proposed in [161] to reduce the negative impact of integrating small onshore wind farms for the 11kV conventional distribution network. Again, this also would result in an increase to the capital cost of conventional distribution network when REs are connected.

Based on the results in table 17, integrating large onshore wind farms into 20 kV superconductor distribution networks will not cause voltage regulator issues in the network. Consequently, the use of wind energy convention control systems is no longer required for wind turbines when

superconductor distribution networks are considered to maintain voltage within limits. The additional cost of equipment for future onshore farms is no longer required to be installed in the future superconductor distribution network. The voltage change behaviour in the superconductor distribution network was different to voltage changes behaviour in 20 kV conventional distribution network. This because HTS cable (40 MVA), used in this study has inductive reactance, which means they consume reactive power which leads to a rise in voltage level up.

This case study confirmed that HTS assets eliminate voltage regulation issues in distribution networks. Moreover, it proved that they can be implemented with MV distribution networks injecting more power from REs without causing any voltage regulation issues and without needing to use any special or additional equipment in order to keep voltage within required limits. This will help to reduce the capital cost of distribution networks in the future. However, the comparisons of 20 kV conventional and superconductor distribution networks are required to see how much capital cost can be reduced in the future when the superconductor equipment is applied with this present network.

### **5.3. Capital cost comparisons of case study network**

The capital cost comparison of a 20 kV conventional and superconductor distribution network have been evaluated in this study. Based on the assumptions in table 6 and 7 (Chapter 2, P30 and P31), the present capital cost of a 20 kV distribution network which contains 57km of HTS cables and one HTS transformer is £1141.2M while the capital cost for a 20 kV conventional network is £5.3M. The future capital cost of a superconductor

distribution network will be £115.1M based on the prices of HTS equipment which are indicated in table 6 and 7. Based on the results, the capital cost of a 20 kV superconductor distribution network is much higher than a current 20 kV conventional distribution network. Although, the capital cost of the 20 kV superconductor network will be significantly decreased in the future but it is still higher by £109.8M from the present capital cost of a 20 kV conventional one in this case study network. This means, HTS cables and transformers will be not suitable to be implemented with small applications of distribution networks like this case study network, but it might be more beneficial to apply HTS equipment to large applications. This raises the question of finding a suitable application for applying HTS equipment with distribution networks in terms of reducing capital cost of the network. HTS technologies such as cables and transformers have proved their ability to overcome several issues, which are associated with existing conventional technologies, therefore, in the future, the HTS technologies are estimated to cover a total UK market value up to £96 billion by the year 2020 [163]

This study aimed to answer the question of the impact of future demands and future RE sources on the existing MV conventional and superconductor distribution networks in terms of voltage regulator issues and capital cost. Applied HTS equipment with MV distribution networks leads to an elimination of the voltage regulation problems especially when future wind energies are connected. Additionally, the voltage control devices are no longer required to be implemented in an MV superconductor distribution network to keep voltage within the required limit. In this practical application, the capital cost of a 20 kV superconductor distribution network

will be higher in the future by £109.8M than the capital cost of 20 kV conventional distribution network. This means, more research must be undertaken in the next section to find out the suitable application of applying HTS equipment with distribution networks to result in lower capital costs than the existing conventional distribution network designs

#### **5.4. Reduce the capital cost for future superconductor distribution networks**

The UK government's objective is to reduce CO<sub>2</sub> emissions by 80% in 2050 as target [164]. Therefore, this chapter uses a 2050 target, which is expected to lead to a reduction in power losses in conventional distribution network. Transmitting power at different voltage levels in conventional distribution networks influences the magnitude of current that flows through the network's components such as cables, overhead lines and transformers. By delivering power at a higher voltage level, the amount of current that is required to be transmitted through the distribution network is decreased; therefore the power losses are decreased. However, transmitting power at higher voltage levels increases the capital cost of power systems including the cost of insulation of cables and substations. Lowering the voltage has the opposite effect on power losses and costs [9]. Consequently, many studies have attempted to introduce a new design for conventional distribution networks [9],[10]. Superconductor power systems allow us to utilise deliver high power capacities (3-5times) at lower voltage level power losses than conventional power systems. Moreover, superconductor power systems provide the opportunity to utilise the removal of intermediate voltage levels which save on power system costs. This will be difficult to

achieve in distribution networks where conventional equipment is used as at lower voltage levels, as the resulting higher current will lead to higher power losses. The power transmission in distribution networks is called complex power and can be expressed as equation 27.

$$S = V \times I^* \quad (27)$$

Where  $S$  is a complex power,  $V$  is voltage level in networks and  $I^*$  is complex current.

Whereas, real and reactive power losses are increased when increasing the amount of current which flows through the conventional networks because of whole network. The total power loss in a distribution network can be determined by equations 28 and 29.

$$P_{\text{loss}} = \sum_{i=1}^{N_{\text{br}}} |I_i|^2 R_i \quad (28)$$

$$Q_{\text{loss}} = \sum_{i=1}^{N_{\text{br}}} |I_i|^2 X_i \quad (29)$$

Where,  $P_{\text{loss}}$  is real power losses ,  $Q_{\text{loss}}$  is reactive power losses,  $N_{\text{br}}$  is the number of branches in the distribution network;  $I_i$  is the magnitude of current flow in the branch and  $R_i$  and  $X_i$  are the reactance and resistance of the branch.

However, the real power losses in conventional conductors can be reduced by reducing the value of a cable's resistance. The resistance of a cable relies on the value of resistivity of the conductor material and the length of cable. As the length of cable increases, the resistance also increases; however, as the cross sectional area is increased the resistance of the cable is reduced. The resistance of conventional cable is determined by equation 30 [165].



$$R = \frac{\rho \times L}{A} \quad (30)$$

Where, R is resistance of cable,  $\rho$  is the resistivity of cable, L is length of cable and A is the cross sectional area of cable.

Since HTS materials provide very low impedance to AC when cooled to the boiling point of liquid nitrogen (77K), interest in using HTS materials to produce power cables and transformers is growing rapidly. HTS transformers and cables promise to reduce power losses significantly in cables and transformers. Moreover, HTS cables can deliver significantly more power (3–5 times) than conventional cables at a lower voltage level, therefore they provide the opportunity to reduce grid congestion problems in urban areas. Although implementing an AC distribution system with HTS equipment results in AC power losses such as hysteric losses and eddy current losses, these AC losses are up to 86% less than those resulting from conventional power system conductors [157]. Furthermore, HTS tapes are available for using in the windings of transformers. Using HTS materials in transformers provides several benefits over conventional transformers, including higher power density, lower operating losses, fault current limiting, lower impedance, and better voltage regulation [48],[57].

The present study investigates the practical effects of installing HTS equipment and seeks to identify novel network designs which make best use of the attributes of superconducting network assets.

#### **5.4.1. Case study**

A case study was adopted from generic distribution network (GDN) models. The case study network has been developed using IPSA software. This

network was chosen because it has intermediate voltage level networks, which was appropriated for this particular investigation to see how HTS assets aid the reduction of capital cost in distribution networks. The network consists of 22 loads, 61 transformers, distributed generation (DG) and 129.7 km of overhead lines and underground cables. Figure 35 shows the voltage levels in the generic distribution network with composite loads [166].

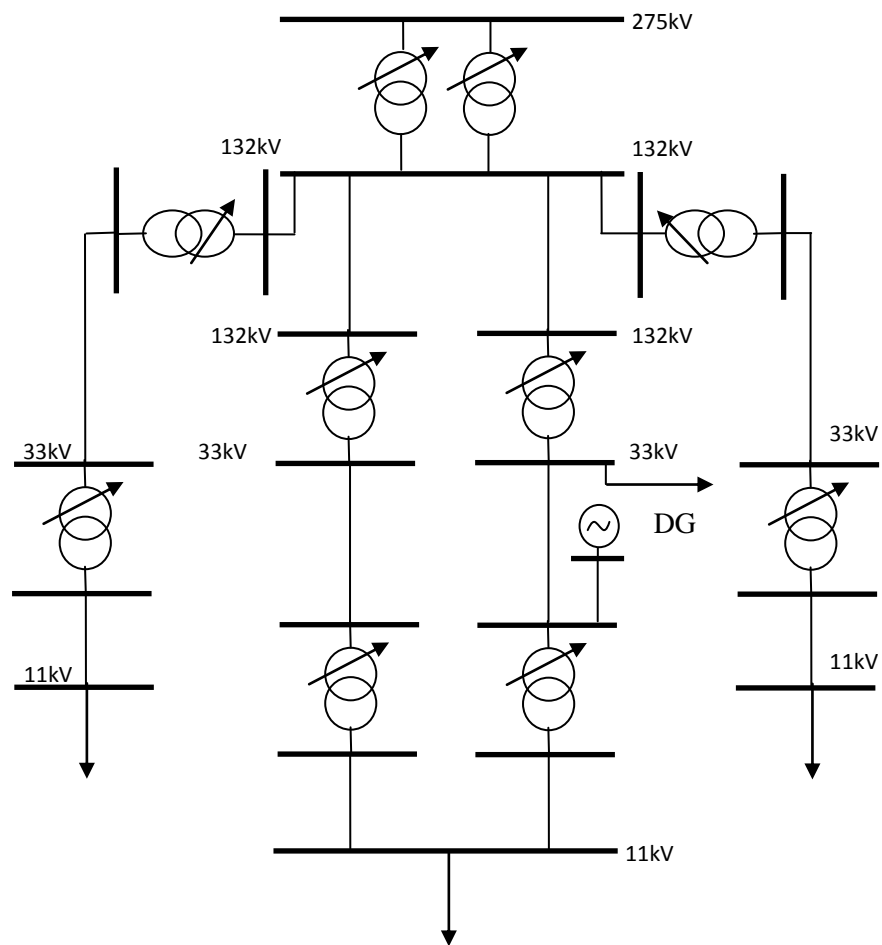

Figure 35: The IPSA model for generic distribution network with composite load

The study is started with the possible future designs that can be implemented with the existing conventional distribution network design to attempt to reduce power losses and capital costs in the network. Further study is carried out to introduce the potential impact of superconductors in alternative distribution network designs on reducing power losses and capital costs of distribution networks in the future.

#### **5.4.2. Modelling a superconductor distribution network**

The major benefit gained from applying superconductor equipment such as HTS cables and HTS transformers into distribution networks is exhibited in very low impedances which can reduce power losses that occur in conventional equipment such as cables and transformers. The parameters of HTS cables and HTS transformers have been used to model superconductor distribution networks. All conventional cables and transformers have been replaced by HTS cables and HTS transformers to create a superconductor distribution network. Based on [34],[92],[141],[167], the impedance of the HTS cables is obtained and converted to a per unit basis, while based on [146],[168] and [169], the impedances of the HTS transformers are obtained and converted to a per unit basis on the transformer MVA base.

#### **5.5. Investigation strategy**

Various possible design strategies have been investigated with the conventional GDNs to find out how these designs impact on losses. These designs were adopted from [170]. Afterwards, the same network designs were investigated in GDNs when HTS cables and transformers simply replaced the conventional equipment to quantify the impact of HTS technologies on losses. These designs are explained briefly as follows.

**Design 1:** This design removes the 33kV network by extending the 11kV network instead. Figure 36 shows the voltage levels in the generic distribution network with composite loads after implanted the design 1

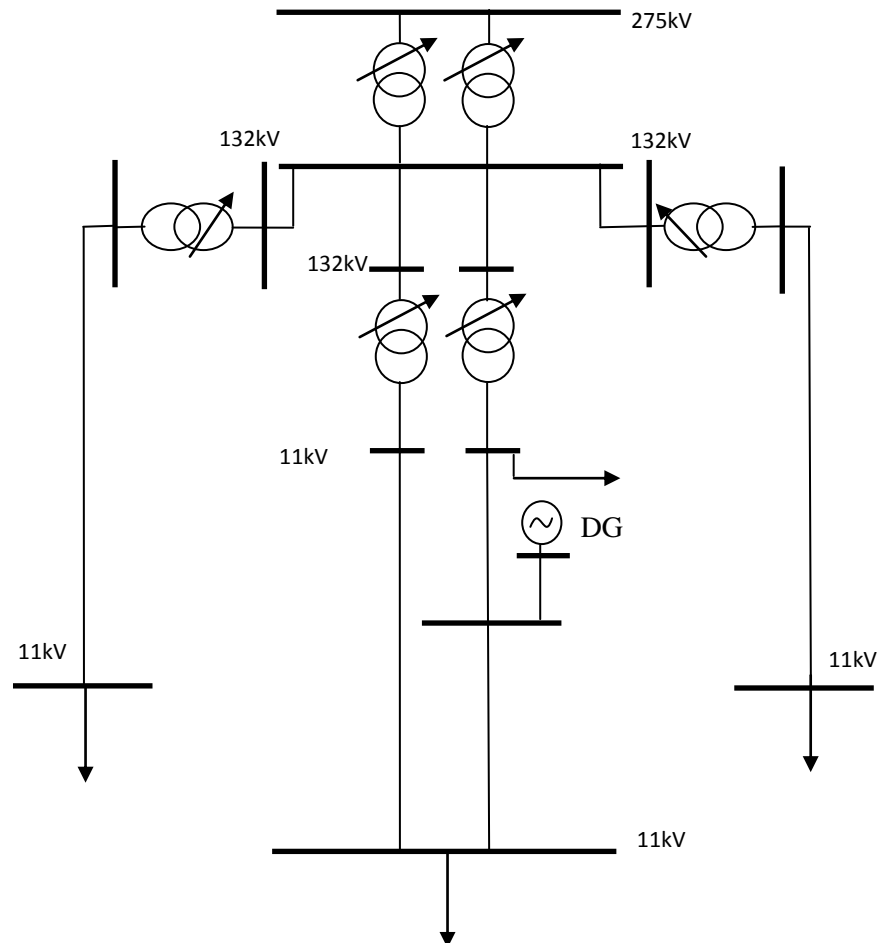

Figure 36: The voltage levels in the generic distribution network with composite loads after implanted the design1

**Design 2:** This design also removes the 33kV network by extending 132kV of the network instead and keeping 11kV of the network the same. Figure 37 shows the voltage levels in the generic distribution network with composite loads after implanted the design 2.

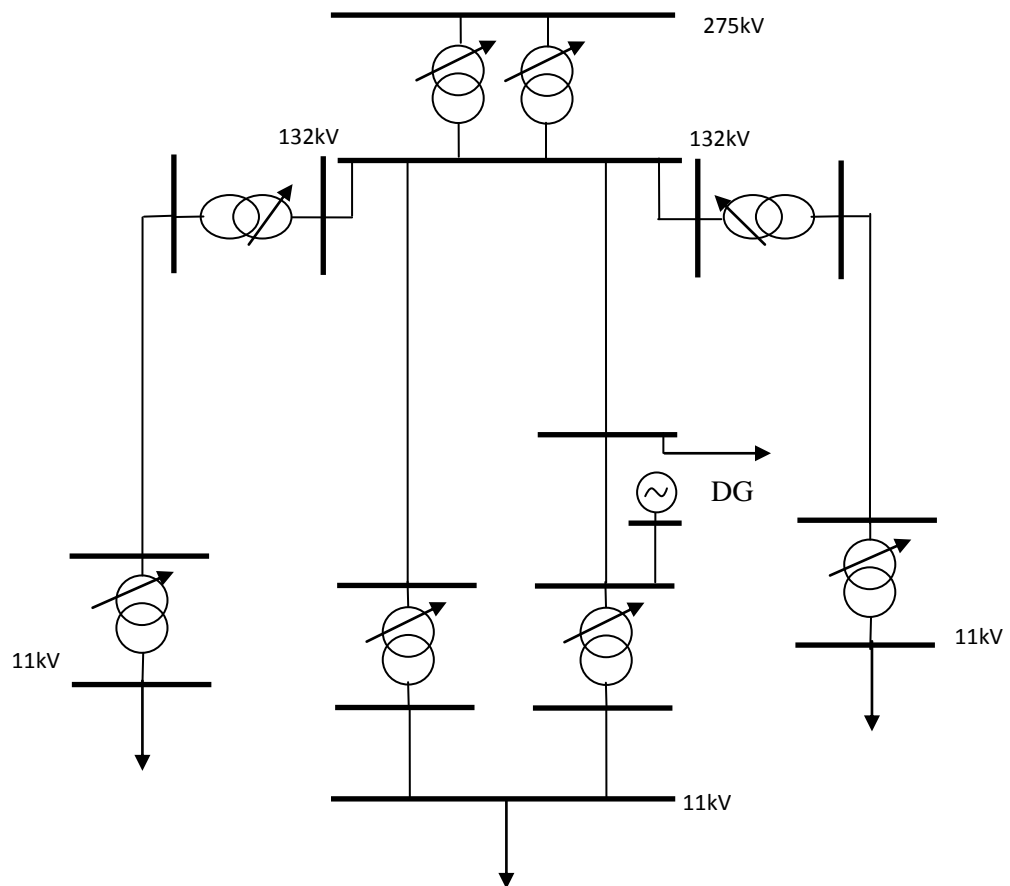

Figure 37: The voltage levels in the generic distribution network with composite loads after implanted the design2

**Design 3:** This design reduced the length of the 11kV network to half-length and offset it by extending the 33kV network instead.

Afterwards, the evaluation of capital costs for the existing conventional and future superconductor network designs is introduced to see that the reduction of capital cost can be achieved by implementing superconductor equipment in alternative distribution network designs.

### 5.6. Total power losses comparisons

Figure 38 shows the results of total power losses at peak demand for conventional and superconductor distribution network designs. When designs 1, 2 and 3 were considered with conventional distribution networks, the total conventional network losses of the present network and of the future network designs at peak demand were recorded as: 5.9% (present), 4.98% (design 1), 4.3% (design 2) and 5.23% (design 3). One of the future designs that can be considered in this investigation with a conventional distribution network is to increase the size of the 11kV conductor in the present conventional distribution network to reduce the impedance of the whole system. Based on the results, the total power losses have reduced by 1.2% of total power losses incurred with the current design of conventional distribution networks when an alternative design was considered with the conventional network. However, increasing the size of the conventional conductor leads to an increase in the capital cost of the whole system.

Afterwards, the same network designs were investigated in GDNs when HTS cables and transformers simply replaced the conventional equipment to quantify the impact of HTS technologies on losses. However, HTS cable and HTS transformers need to operate at a temperature of no more than 77 Kelvin (K), which is the boiling point of liquid nitrogen, to provide very low impedance. Thus, it is necessary to use a refrigeration system to keep the temperature of HTS cable and HTS transformer within the required limit of temperature (77K). Power needs for refrigeration systems are considered as real power losses in HTS cables and HTS transformers. For that reason, the consumption of power by refrigeration systems is added to the real power

losses of HTS cables and transformer to find the total real power losses in the superconductor distribution network. The power needs of a refrigeration system to keep HTS cables operating at 77K is approximately 2 to 5 kW/km while the power needs of a refrigeration system to keep 30MVA HTS transformer operating at 77K is 6kW (more details in chapter 4 P103 and P104). In this study, the assumed power requirement of each refrigeration unit for HTS cables is 5kW/km while the power consumption of refrigeration system for an HTS transformer is 6kW per 30MVA. When designs 1, 2 and 3 were considered with distribution network containing HTS cables and transformers, the total superconductor network losses of the present network design and of the future network designs at peak demand are: 0.59% (present), 0.54% (design 1), 0.5% (design 2) and 0.56% (design 3). These power losses include the power consumption for refrigeration systems for HTS cables and transformers.

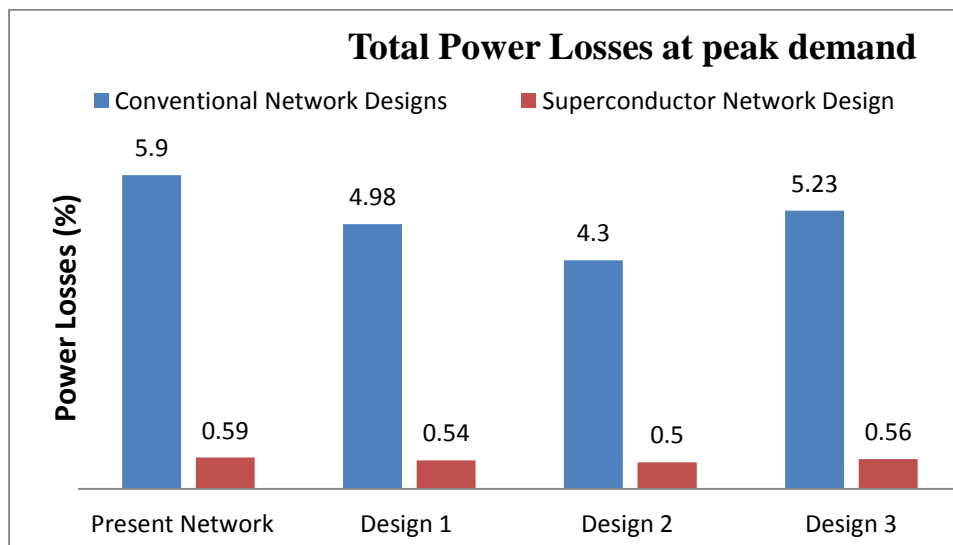

Figure 38: Total power losses comparisons

### 5.6.1. Results Discussing

Results in figure 37 proved that the total power losses in conventional network designs (1 and 2) saved approximately 0.92% and 1.6% from total power losses that occurred in the present conventional network at peak demand. However, the total power losses in networks containing HTS cables and HTS in such designs, can save 5.31% (present), 5.36% (design 1) and 5.4% (design 2) from total power losses were in the present conventional network design for the same condition. Consequently, this study has emphasised that the total power losses implemented in these designs in conventional and superconductor networks (1 and 2) could be reduced. The total power losses which resulted in conventional and distribution networks with design 2 were the lowest because design 2 networks were aimed to deliver power at a higher voltage level (132kV network), while networks with design 1 were aimed to deliver power at lower voltage level (11kV network). However, implementing design 2 with a distribution network leads to reduced power losses but the cost of cable insulations and substations will be increased which resulted in the capital cost in distribution networks. Therefore, design 3 was suggested to be one of designs which can be applied with the present conventional distribution network to reduce the power losses that occurred in the 11kV network by reducing the length of 11kV network and extending the 33kV network. The result showed that total conventional network losses with design 3 can only be saved by 0.67% of total power losses which resulted in the present conventional network design at peak demand while about 5.34% of total power losses can be saved in a superconductor network (design 3) from the



total power losses that occurred in the present conventional network design for the same condition. Applying design 3 with superconductor and conventional distribution networks has resulted in the highest total power losses because the total power losses which were saved from the 11kV network were offset by the 33kV network.

However, the capital cost of these designs ,when HTS equipment is considered, is very high compared with conventional distribution designs (up to 8 times greater than conventional equipment) [62],[63], due to the high cost of HTS equipment. Hence, implementing these designs in distribution networks with HTS equipment results in a reduction in losses but does not aid in reducing capital cost of distribution networks. The optimal solution for the network would be a novel superconductor distribution network design that thus lowered losses but also achieved this at a lower or comparable capital cost when compared to the current conventional design.

### **5.7. New possible designs of superconductor networks**

HTS cables have the potential to carry a high amount of power at lower voltage with lower losses (this is not possible with conventional equipment). The new design of superconductor networks can be introduced in order to reduce the power losses with lower capital cost as compared with conventional distribution networks. Two possible superconductor distribution network designs can be achieved and compared in terms of power losses and capital cost .The 10kV HTS cable produced Nexans is now available in the market and can deliver power up to 40MVA [34]. The new topology network design can be achieved using 10kV HTS cables by

transferring power from 275kV to 10kV then straight down to customer voltage levels (0.4kV). The 10kV superconductor distribution network design provides the potential to remove intermediate voltage levels such as 132kV, 33kV and 11kV networks and substations by delivering power from 275kV to 10kV network, and then down to supply customers at 0.4kV. This design cannot be implemented using conventional cables because the amount of current will be high at 10kV, which would result in increased power losses in the networks. However, HTS cables have very low impedance with high power capacity (3-5 times more); therefore, the power losses will be significantly reduced even at a lower voltage level (10kV), with higher power delivery. Figure 39 shows a 10kV superconductor distribution network.

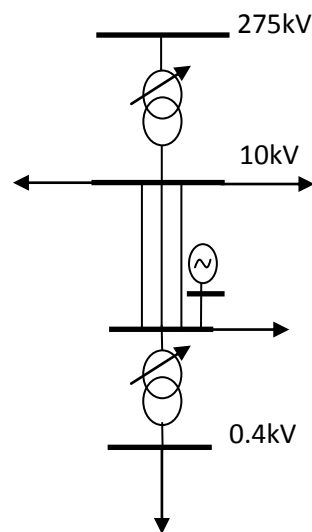

Figure 39: The simple 10kV superconductor distribution network with composite loads

Another design can be accomplished for distribution networks using 33kV HTS cable. The company Innopower superconductor cable Co for high

temperature superconductivity have introduced a 33kV HTS cable which can deliver power up to 100MVA at 33kV [63]. Therefore, the number of 33kV HTS cables which were required to be used with 33kV superconductor network is less than the number of 10kV HTS cables which were required to be used with 10 kV superconductor network. A new 33kV superconductor distribution network has been applied to transfer power from 275kV to 33kV and then down to supply customers at a low voltage level (0.4kV) as shown in Figure 40. These designs of superconductor distribution networks have not considered any redundancy systems to maintain delivering power loads in case a fault occurs in any part of these networks. They are designed to deliver the power at peak loads. For that reason, the fault and risk studies have not been introduced in this chapter, but will be introduced in the next chapter. Figure 40 shows the voltage levels in design of superconductor (SC) distribution networks using 33kV HTS cables.

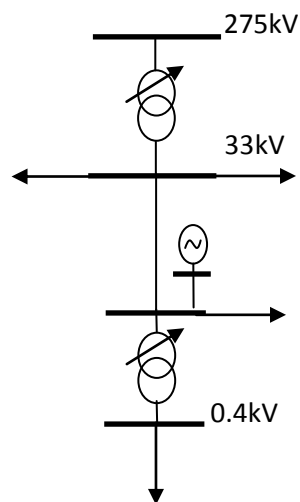

Figure 40: The simple 33kV superconductor distribution network with composite loads

A comparison of total power losses at peak demand between these networks has been investigated. Based on results as shown in figure 41, the total power losses at peak demand can be reduced by 5.42% in a 10kV superconductor network from the total power losses that were found in a present conventional network design, while the total power losses in 33kV superconductor distribution network can be reduced by 5.7% from the total power losses incurred in a present conventional distribution network.

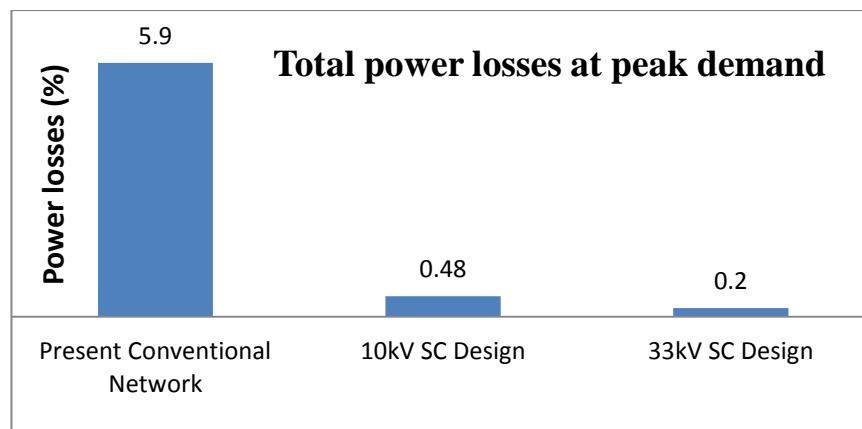

Figure 41: Total power losses comparisons for 10kV and 33kV superconductor network designs at peak demand

It is clear that the 33kV superconductor network design resulted in lower total power losses than the 10kV superconductor network design, therefore the comparisons of the cost of energy losses per year for a 33kV superconductor network design and the present conventional network has been investigated as shown in figure 42. The energy losses in this case for conventional distribution network are 4075 MWh/year. In a superconductor network, energy losses are at HTS cables and transformers, plus the power consumption by refrigeration systems of HTS cables and transformers. For that reason, the energy consumption attributable to the refrigeration systems

associated with HTS transformers and cables is 2312.2MWh per year while the energy losses in the superconductor network are 815MWh per year. From [151], the cost of energy losses is £60/MWh. Thus, energy losses in a conventional network cost £244.5k/year whereas energy losses in a network comprising HTS cables and an HTS transformer cost £187.6 k/year. Using HTS cables and transformers in an 33 kV distribution network can reduce the cost of energy losses by £57 k / year, leading to a cost saving of £ 285k over a five year period when compared to a conventional network. However, the capital cost of these two superconductor network designs must be calculated to find out the best design which results in lower power losses and lower capital cost. Before, the capital cost of superconductor network designs is calculated the present and projected cost of HTS technologies is needed to evaluate the capital cost of superconductor network designs. All calculations are shown in the Appendix 3.

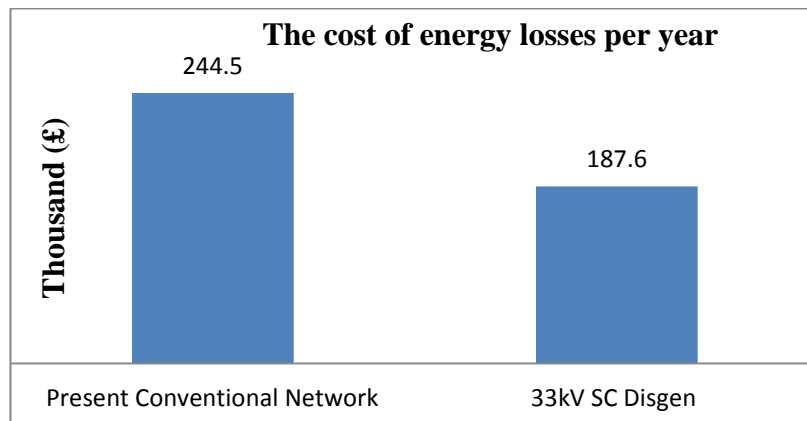

Figure 42: The cost of energy losses comparisons

### 5.7.1. Capital cost comparisons

Based on tables 6 and 7 (Chapter 2, P30 and P31), the capital cost of 33 kV and 10 kV superconductor network designs have been calculated in the

present and in the future based on changing costs with HTS materials in future. These superconductor network designs provide potential to carry a high amount of power at lower voltage with lower losses; therefore 132kV, 6.6kV and 11kV substations and networks can be removed from the system. Based on tables 6 and 7, the capital cost of 33 kV and 10 kV superconductor network designs have been calculated in the present and in the future based on changing costs of HTS materials in future. These superconductor network designs provide potential to carry a high amount of power at lower voltage with lower losses; therefore 132kV, 6.6kV and 11kV substations and networks can be removed from the system. This would result in reduced capital cost of superconductor network designs. Figures 43, 44 and 45 show the present capital cost and projected capital cost for superconductor network designs with the present cost conventional distribution network.

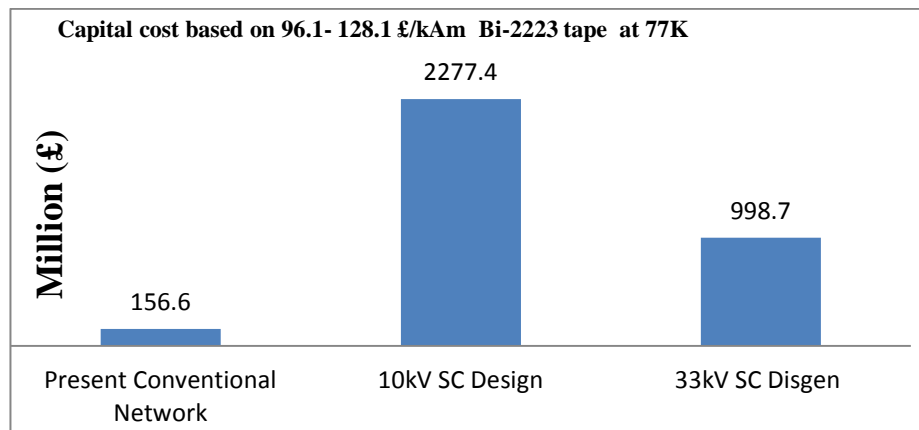

Figure 43: The capital cost comparisons between new designs of superconductor networks and present conventional network when Bi-2223 wire and cooling system is £128.1/kAm and £620/m

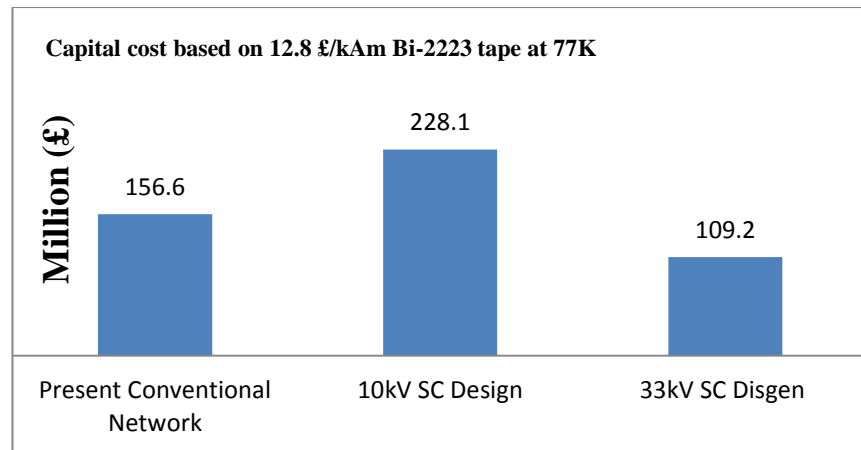

Figure 44: The capital cost comparisons between new designs of superconductor networks and present conventional network when Bi-2223 wire and cooling system is £12.8/kAm and £620/m

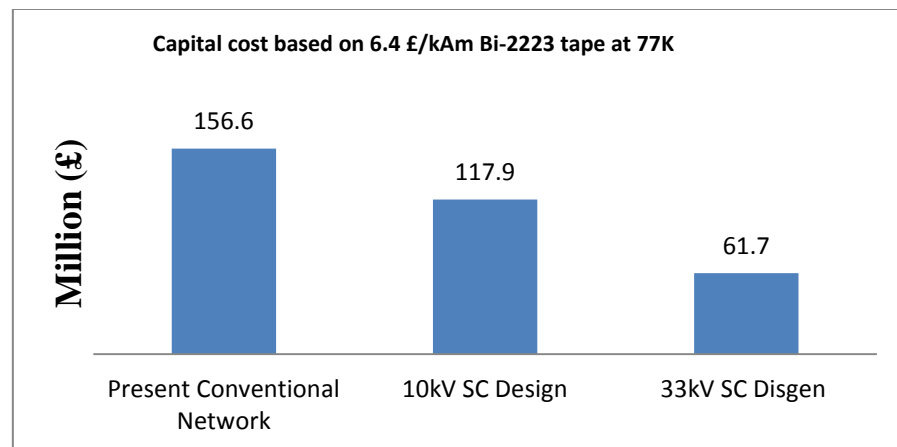

Figure 45 : The capital cost comparisons between new designs of superconductor networks and present conventional network when Bi-2223 wire and cooling system is £6.4/kAm and £620/m

Based on results which are shown in above figures, a 10kV superconductor distribution network design has the opportunity to remove the intermediate voltage levels such as 132kV and 33kV, therefore all substations and networks have been removed in these voltage levels. This led to a reduction in the capital cost of 10kV superconductor distribution networks. Figure 43 shows that the present capital cost of a 10kV superconductor distribution network design is significantly higher by 2.1 billion than the present capital

cost of the conventional distribution network, when the Bi-2223 wire and cooling system is £128.1/kAm and £620/m. The reason of the present capital cost of the superconductor distribution network set very high is because the cost of HTS equipment is very high (8 times more than conventional equipment), which results in an increase of the capital cost of a 10kV superconductor distribution network. However, this 10kV superconductor network design has the ability to deliver power (3-5 times more conventional cables) at lower voltage which aids to reduce the cost of insulation and substations. Based on the result which is shown in figure 43, this capital cost of the 10kV network design might be less by £38.7M than the capital cost of the present conventional distribution network, when the cost of Bi-2223 tape is expected to reach 6.4 £/kAm.

In addition, the present capital cost of a 33kV superconductor distribution network is still higher by £842.1M than the present capital cost of the existing conventional distribution network because the cost of equipment is expensive in the present system whereby Bi-2223 wire and the cooling system is £128.1/kAm and £620/m. Moreover, the results show that the capital cost of the 33kV superconductor network design will be £47.4 M less than the capital cost of the current conventional network design by 2016- 2020, when the cost of Bi-2223 tape is expected to reach 12.8 £/kA. Moreover, Some researchers indicate that the cost of Bi-2223 tapes may decrease to 6.4 £/kA in the future, which means the capital cost of 33kV superconductor network design will be £95M less than the capital cost of the present conventional network design[63],[64].



### 5.8. Summary

This chapter introduces the possible future designs for a superconductor distribution network that will result in lower losses and also have a lower capital cost when compared to the current conventional design. Applying HTS technologies with distribution networks must be in large applications to gain advantage of removing voltage levels and conventional technologies to control voltage levels in the network. Implementing a 33kV superconductor network design in 2020 could save £47.4M from the capital cost of the current conventional network design, while up to £95M could be saved from the capital cost of current conventional networks in the near future. Moreover, using HTS cables and transformers in an 33 kV distribution network can reduce the cost of energy losses by £57 k / year, This implies that using HTS technologies with larger distribution networks is more beneficial in terms of reducing capital cost and power losses in the whole distribution system.

However, the risk level of 33kV superconductor network design is very high compared with current conventional network due to the redundancy systems that have not been applied to the 33kV superconductor network design. Consequently, further work will be focused on introducing a new 33kV superconductor network design for lower power losses, capital cost and risk level than present conventional distribution networks. The next chapter will address a new 33 kV design of a superconductor distribution network which will result in lower power losses, lower capital cost and lower risk levels than the existing conventional distribution design.

## **6. Reduction of the risk level in future superconductor distribution networks**

HTS cables are superior to conventional equipment because of their potential to carry larger amounts of power at low voltage with lower power losses [62],[63]. Chapter 6 has proposed a new design for a 33kV superconductor network which has demonstrated lower power losses and capital cost when compared with the power losses and capital cost associated with conventional distribution networks. Many studies have proposed new designs for superconductor distribution networks that target a reduction in the capital cost and in power losses which exist in conventional distribution network designs. They imply that using HTS technologies within larger distribution networks offers future benefits in terms of reducing capital cost and power losses associated with current distribution network designs [100],[101],[102],[103]. However, the risk associated with operating the future superconductor distribution network designs is much higher than the risk associated with the existing designs because the superconductor distribution networks do not include any redundancy systems such as (n-1) to maintain customer supplies in the event of a short circuit. Including a redundancy system such as (n-1) for future superconductor distribution network designs increases capital cost because of the high cost of HTS technologies for power systems. Therefore, any new planned superconductor distribution network should result in lower

power losses, carry lower levels of risk and have a lower capital cost than the present conventional distribution network design.

This chapter evaluates comparable risk studies between existing conventional distribution networks and the new 33kV superconductor distribution network obtained from previous studies (Chapter 6), and proposes a new design for a 33kV superconductor distribution network, that has the desirable attributes listed above using the case study referred to in Chapter 6 adopted from GDN designs. Also, the study demonstrates the failure rating of superconductor and conventional network circuits to evaluate many calculations in networks, such as the probability of power loss for customers' repair costs, customer interruptions, restoration time costs, the customer's minutes lost costs and total network risk of such a network design. Furthermore, this study introduces the impact of faults on technical and economic aspects of novel future design of superconductor networks and the existing design of conventional networks.

### **6.1. Conventional case study network**

Figure 46 shows the conventional case study network used in this study, it has been simplified to fit with the case study. The network introduces the relevant 132 kV, 33 kV, and 11 kV circuits such as circuit breakers (CBs) for cables and all associated ancillary assets for the transformers. The present configuration of the conventional distribution network has been classified into nine zones to introduce the network configurations with all voltage levels in conventional network in more detail as shown in table 18.

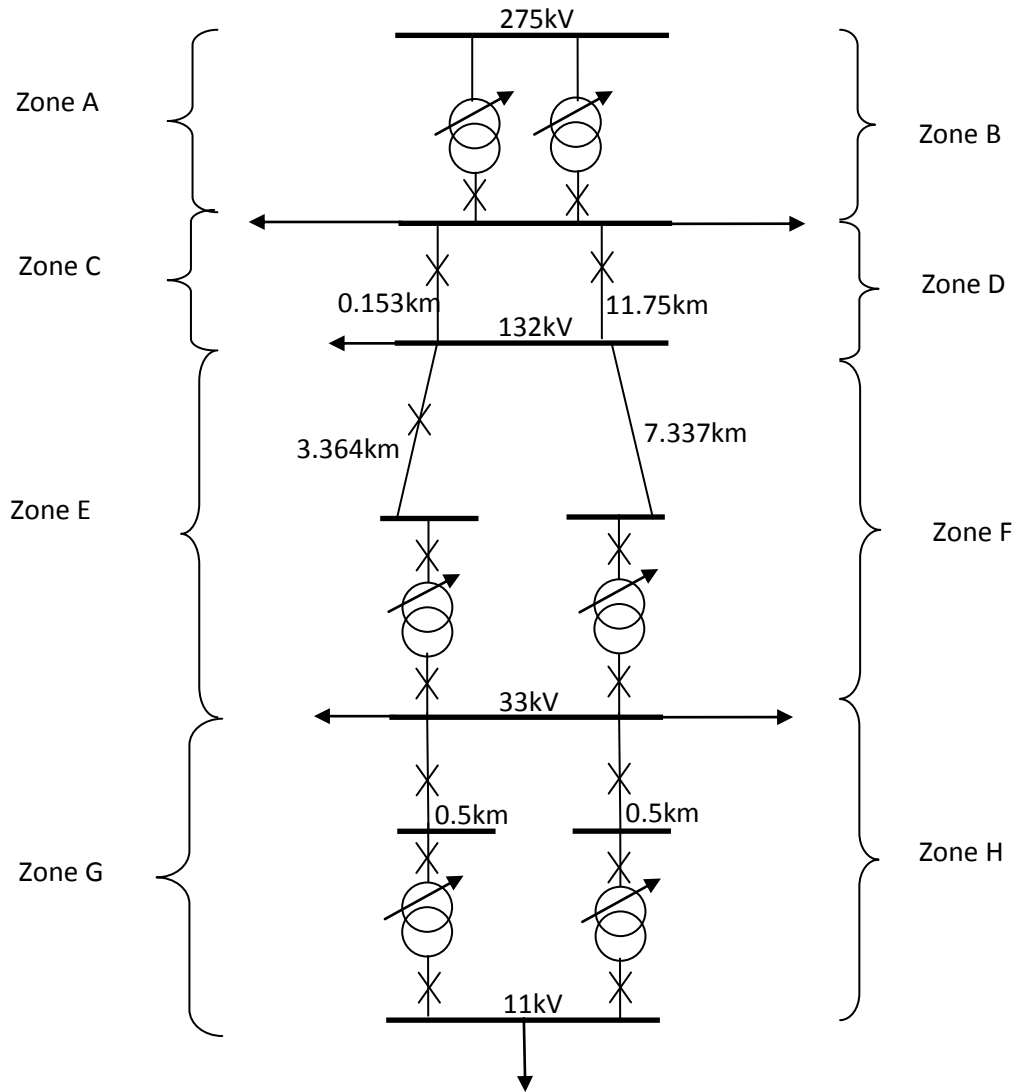

Figure 46 : Present configuration of case study conventional network

Table 18: All relevant 132kV, 33kV and 11kV circuits and transformers with all associated ancillary assets

| Zone | Assets                                                                                                                                           |
|------|--------------------------------------------------------------------------------------------------------------------------------------------------|
| A    | One transformer 275/132kV with all associated ancillary assets and 132kV CB                                                                      |
| B    | One transformer 275/132kV with kV                                                                                                                |
| C    | 0.153km of 132kV overhead lines and one 33kV CB                                                                                                  |
| D    | 11.75km of 132kV overhead lines and one 33kV CB                                                                                                  |
| E    | 3.364km of 132kV overhead lines, one 132kV CB, one transformer 132kV/33kV with all associated ancillary assets and one 33kV CB and one 132kV VCB |
| F    | 7.337km of 132kV overhead lines, one 132kV CB, one transformer 132kV/33kV with all associated ancillary assets and one 33kV CB and one 132kV VCB |
| G    | 0.5km UG cables, one transformer 33kV/11kV with all associated ancillary assets and three 33kV CBs                                               |
| H    | 0.5km UG cables, one transformer 33kV/11kV with all associated ancillary assets, two 33kV CBs and one 11kV CB.                                   |

## 6.2. Conventional distribution network - risk assessments

### 6.2.1. Failure rates assumptions

The risk calculation for the conventional distribution network shown in figure 46 has introduced failure rates for all assets for network circuits. Failure rates for all assets in each zone (using data from [171]) are listed below (table 19).

Table 19 : Failure rates for conventional network circuits

| Asset Category               | Failure Rate |
|------------------------------|--------------|
| 132/33kV OHL ,per meter      | 0.032        |
| 132/33kV UG ,per meter       | 0.0376       |
| 132/33 kV CB                 | 0.0303       |
| 11 kV CB                     | 0.0259       |
| 132/33/11 kV Transformer     | 0.0276       |
| All ancillary assets, per TX | 0.0448       |

The average failure rating for conventional cables and transformers, which is shown in table 19, is taken from [171]. These numbers have been assumed based on the historic events of failure ratings for cables and transformers from real networks. More information is presented in [171].

### 6.3. Calculation methodology of the Conventional distribution network

The calculation methodology is adopted from [171]. The risk level of the conventional study network has been achieved in seven steps. These steps are provided as follows.

#### 6.3.1. Add failure rates to each zone

With reference to the assets listed in tables 19 and 18, and using the failure rates in table 20, an overall failure rate for zone A can be calculated:

The calculation of the average failure rate in zone A depends on the calculation of the total average failure for all equipment in that zone. Therefore, the total average failure rate in zone A consists of an average

failure rate for one transformer 275/132kV with all associated ancillary assets added to the average failure rate for 132kV CB as shown in table 18.

$$(0.0276 + 0.0448 + 0.0303) = 0.103 \text{ failure /year}$$

In the same way the overall failure rate for all zones has been calculated:

$$\text{Zone B} = (0.0276 + 0.0448 + 0.0303) = 0.103 \text{ failure /year}$$

$$\text{Zone C} = (0.153 \times 0.032) = 0.0049 \text{ failure /year}$$

$$\text{Zone D} = (11.75 \times 0.032) = 0.376 \text{ failure /year}$$

$$\text{Zone E} = (3.364 \times 0.032) + (0.0276 + 0.0303 + 0.0303 + 0.0448) = 0.24 \text{ failure /year}$$

$$\text{Zone F} = (7.337 \times 0.032) + (0.0276 + 0.0303 + 0.0303 + 0.0448) = 0.37 \text{ failure /year}$$

$$\text{Zone G} = (0.5 \times 0.0376) + (0.0303 + 0.0259 + 0.0448 + 0.0276) = 0.147 \text{ Failure /year}$$

$$\text{Zone H} = (0.5 \times 0.0376) + (0.0303 + 0.0259 + 0.0448 + 0.0276) = 0.147 \text{ failure /year}$$

### 6.3.2. Estimated proportion of failures

The percentage of proportional failures made in the present study is as follows, based on the degree of geographical and electrical proximity between circuits under normal operation [171].

- A fault in zone A has a 15% chance of being followed by a fault in zone B before A is restored and a negligible chance of being followed by fault in zones C and D.

In the same way, the assumptions relating to the percentage of proportion of failures for all zones have been achieved and they are provided as follows:

$$\left. \begin{array}{l} A \rightarrow B \\ B \rightarrow A \end{array} \right\} 15\%$$

$$\left. \begin{array}{l} C \rightarrow D \\ D \rightarrow C \end{array} \right\} 15\%$$

$$\left. \begin{array}{l} E \rightarrow F \\ F \rightarrow E \end{array} \right\} 15\%$$

### 6.3.3. Calculating the probability of power failure for customers

The calculation of the probabilities of customers losing power has been undertaken based on the previous step. Should (n-1) failure occur in any zone in the network, power will still be delivered to all customers. For example, (n-1) failure in zone A will not result in loss of power for any customers in the network because zone B will maintain customer supplies. However, an (n-2) failure in any part of the network will result in a loss of supply power for customers. This step can be calculated as follows:

- Loss of A only =  $0.103 \times 0.85 = 0.087$
- Loss of B only =  $0.103 \times 0.85 = 0.087$
- Loss of both zones =  $(0.103 \times 15\%) + (0.103 \times 15\%) = 0.0309$
- Loss of C only =  $0.0049 \times 0.85 = 0.0042$
- Loss of D only =  $0.376 \times 0.85 = 0.32$
- Loss of both zones =  $(0.0049 \times 15\%) + (0.376 \times 15\%) = 0.057$



- Loss of E only =  $0.24 \times 0.85 = 0.204$
- Loss of F only =  $0.37 \times 0.85 = 0.32$
- Loss of both zones =  $(0.24 \times 15\%) + (0.37 \times 15\%) = 0.092$
- Loss of G only =  $0.148 \times 0.85 = 0.126$
- Loss of H only =  $0.148 \times 0.85 = 0.126$
- Loss of both zones =  $(0.148 \times 15\%) + (0.148 \times 15\%) = 0.044$

Total = 1.5 per a year.

#### **6.3.4. Calculation of the repair cost (RC)**

Assuming an average unit cost of £20k per repair (RC), the expected cost of repairs with the present configuration of conventional network is given by:

$$CR = £20,000 \times 1.5 = £30,000 \text{ per year}$$

The number of average unit cost is assumed based on three assumptions: life time for equipment, direct cost of equipment and average value of repairing cost in the network. Life time for equipment is the cost life of equipment. For example, if an overload happens for the transformer, then the life time of it will be cost money. Therefore, £12k is assumed to cover the cost life part for equipment in the whole network per repair.

Direct cost of equipment consists of the cost of facilities which are used to repair the faults in the network such as people and the price of replacing new equipment, for example, circuit breakers. Thus, £6k is assumed to address the direct cost of equipment in the network per repair. A total of £2k is assumed to be the average repair cost. As a result, the average unit cost per repair in the network is the total of life time for equipment, direct cost of

equipment and the average value of a repair cost in the network which is £20k per repair. More information is represented in detail in [171].

### **6.3.5. Calculation of the customer interruptions (CI) costs**

Assuming a unit CI cost of £5, and based on customer numbers (8000 customers) in network:

$$CI = 0.22 \times £5 \times 8,000 = £8,800 \text{ per year}$$

### **6.3.6. Calculation of restoration time (RT) and the customer minutes**

#### **lost (CML) costs**

Based on the restoration time (RT) assumptions in [171], the average restoration time in minutes for customers at low voltage following an EHV fault can be calculated as follows:

$$CML = 0.22 \times £10 \times 8,000 \times 0.8(\text{hour per events}) = £14.1k \text{ per year}$$

### **6.3.7. Calculation of total network risk (TNR)**

Total network risk is obtained as follows:

$$TNR = CR + CI + CML$$

$$TNR = £8,800 + £14,080 + (£10 \times 0.22) = £52.9k \text{ per year}$$

## **6.4. Superconductor case study network**

Figure 47 shows the superconductor case study network which has been investigated in this study. The superconductor network has been simplified to fit with the case study as shown in figure 47. The network introduces the relevant 33 kV circuits such as circuit breakers (CBs) for cables and all associated ancillary assets for transformers. The configuration of a 33kV

superconductor distribution network has been classified into four zones to introduce the network configurations with all relevant 33kV circuits and all transformers with all associated ancillary in more detail. Table 20 indicates details of the 33kV superconductor distribution network configurations with all relevant 33kV circuits and all transformers with all associated ancillary.

Table 20: All relevant 33kV circuits and associated ancillaries of transformers in a 33 kV superconductor distribution network

| Zone | Assets                                                                                                           |
|------|------------------------------------------------------------------------------------------------------------------|
| A    | One transformer 275/33kV with all associated ancillary assets and 33kV CB and one 33kV CB                        |
| B    | 11.75km of 33kV UG and one 33kV CB.                                                                              |
| C    | 7.337km of 33kV UG and one33kV CB                                                                                |
| D    | 0.5km UG cables, one transformer 33kV/0.4kV with all associated ancillary assets, one 33kV CBs and two 0.4kV CBs |

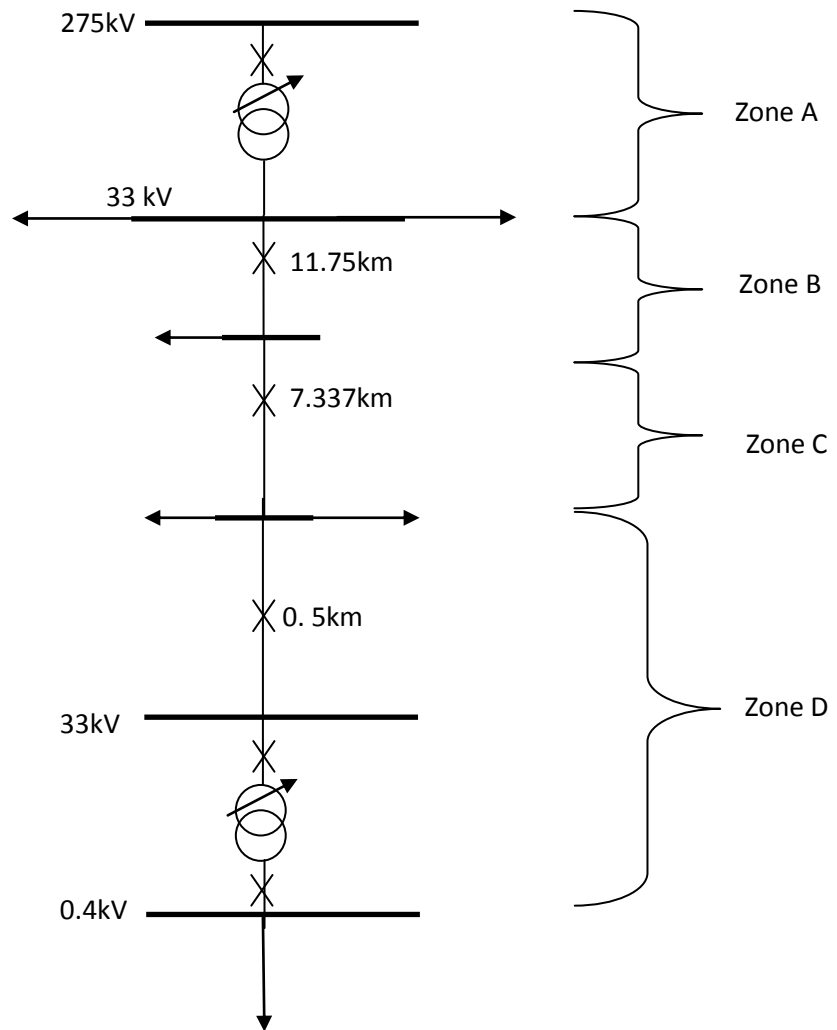

Figure 47: 33kV superconductor network circuits

## 6.5. Superconductor distribution network - risk assessments

### 6.5.1. Failure rates assumptions

The superconductor network risk calculation (figure 46) has been introduced based on the failure rates for all assets for network circuits. Failure rates for all assets in each zone are listed below (table 21), this includes failure rates for refrigeration systems for HTS equipment [172].

Table 21: Failure rates for superconductor network circuits

| Asset Category               | Failure Rate |
|------------------------------|--------------|
| 132/33kV OHL, per metre      | 0.032        |
| 132/33kV UG, per metre       | 0.0376       |
| 132/33 kV CB                 | 0.0303       |
| 11/0.4 kV CB                 | 0.0259       |
| 132/33/0.4 kV transformer    | 0.0276       |
| All ancillary assets, per TX | 0.0448       |
| Refrigeration systems        | 0.37         |

The same average failure for superconductor assets are assumed in this study as shown in table 21. However, the average failure of refrigeration systems for HTS assets needs to be considered. The average failure of refrigeration systems per year are taken from [172].

## 6.6. Calculation methodology of the 33 kV superconductor distribution network

The same methodology has been used to calculate the risk level in the superconductor case study network using failure rates which are given in table 21.

### 6.6.1. Add failure rates to each zone

With reference to the assets listed in table 20, and using the failure rates in table 22, an overall failure rate for zone A can be calculated:

The calculation of the average failure rate in zone A depends on the total average failure for all equipment in that zone. Therefore, the total average failure rate in zone A consists of an average failure rate for one transformer

275/33kV with all associated ancillary assets including a refrigerator system added to the average failure rate for 33kV CB as shown in table 20.

$$\text{Zone A} = (0.0276 + 0.0448 + 0.0303) = 0.103 \text{ failure /year}$$

In the same way, the overall failure rate for all zones is calculated below:

$$\text{Zone B} = (11.75 \times 0.0376) = 0.442 \text{ failure /year}$$

$$\text{Zone C} = (7.337 \times 0.0376) = 0.276 \text{ failure /year}$$

$$\text{Zone D} = (0.5 \times 0.0376) + (0.0276 + 0.0448 + 0.0303 + 0.0259) = 0.15 \text{ failure /year}$$

However, there is an additional failure rating which must be added to each HTS cable and transformer, which is the refrigeration system failure rate as shown in table 21 [172].

### **6.6.2. Estimate of proportion of failures**

The assumptions made in the present study are as follows, based on the strategy which was taken in the conventional distribution network.

- A fault in zone A has a 100% chance of being followed by a zone B fault.

In the same way, the assumption of event probabilities of losing customers for all zones is provided below:

B→ 100%

C→100%

D→100%

### 6.6.3. Calculating the probability of power failure for customers

Calculating the event probability of power loss for customers has been undertaken on the same basis as for the conventional network. Should (n-1) failure occur in any zone in the network, this will result in a loss of supplying power to all customers. This step can be calculated as follows:

- Loss of A only =  $0.103 \times 1 = 0.103$
- Loss of B only =  $0.442 \times 1 = 0.442$
- Loss of C only =  $0.276 \times 1 = 0.276$
- Loss of only D =  $0.15 \times 1 = 0.15$
- Loss of only E =  $0.37 \times 1 = 0.37$  ( for refrigeration systems)

Total = 1.34 per a year

### 6.6.4. Calculation of RC

Assuming an average unit cost of £20k per repair, the expected cost of repairs with the superconductor case study network (figure 46) is given as follows:

$$CR = £20,000 \times 1.34 = £26.8k \text{ per year}$$

This study provides the evaluation of risk studies for the future 33kV superconductor distribution network. Consequently, the projected prices for HTS technologies have been used in this step to predict the future cost of repairing the 33kV superconductor distribution network. The reason for assuming an average unit cost of £20k per repair of the superconductor case study network, which is the same average unit cost per repair of the conventional case study network, is because the price of 33kV cables (based on tables 6 and 7, P30 and P31) is likely to be the same or slightly lower

than conventional cables in the future. However, the average unit cost in the present for repairing the 33 kV superconductor distribution network design is likely to be very high, compared to the average unit cost for repairing the existing conventional distribution network design, because the present price of superconductor technologies is up to 8 times greater than the present price of conventional equipment [62],[63].

#### **6.6.5. Calculation of CI cost**

Assuming a unit CI cost of £5, and based on customer numbers of 8000 over the whole network:

$$CI = 1.34 \times £5 \times 8000 = £53.6k \text{ per year}$$

#### **6.6.6. Calculation of RT and CML costs**

CML can be calculated as follows:

$$CML = 1.34 \times £10 \times 8000 \times 0.8 = £85.7k \text{ per year}$$

#### **6.6.7. Calculation of TNR**

TNR is obtained as follows:

$$TNR = CR + CI + CML = £166.2k \text{ per year}$$

This study showed that a the 33 kV superconductor network design proposed in Figure 47 results in much higher levels of risk than the present conventional distribution network design, which is approximately 3 times more than conventional distribution network design(Figure 46). Therefore, a novel approach to designing a 33 kV superconductor distribution network is required to facilitate lower risk levels.



### **6.7. New 33kV design for a superconductor distribution network**

The need for a new design of 33 kV superconductor distribution network has been identified in section 6.6. The proposed new design of a 33 kV superconductor distribution network incorporates a conventional distribution network to reduce the risk level in the 33 kV superconductor distribution networks as shown in figure 48. Normal open points (NOP) form a key component of this network. During normal operation, NOPs are open and all network demand will be supplied solely by the 33 kV superconductor distribution network. Should a fault occur in any zone in the 33 kV superconductor distribution network, one of NOPs will close and activate the conventional distribution network to maintain power supplies for all customers in the network.

Based on figure 48, the fault zones are categorised into four zones: A, B, C and D. When there is no fault in at any part of 33 kV superconductor distribution network, all demands in the network will be supplied by only the superconductor distribution network by keeping all NOPs open. However, when one of the categories faults in any part of superconductor network, then the conventional distribution network needs to be operated using NOPs to keep supplying all loads in the superconductor distribution network. Operating NOPs (on or off) relies on faults occurring in 33 kV superconductor distribution network. The following explanation demonstrates how the network operated when a fault occurs

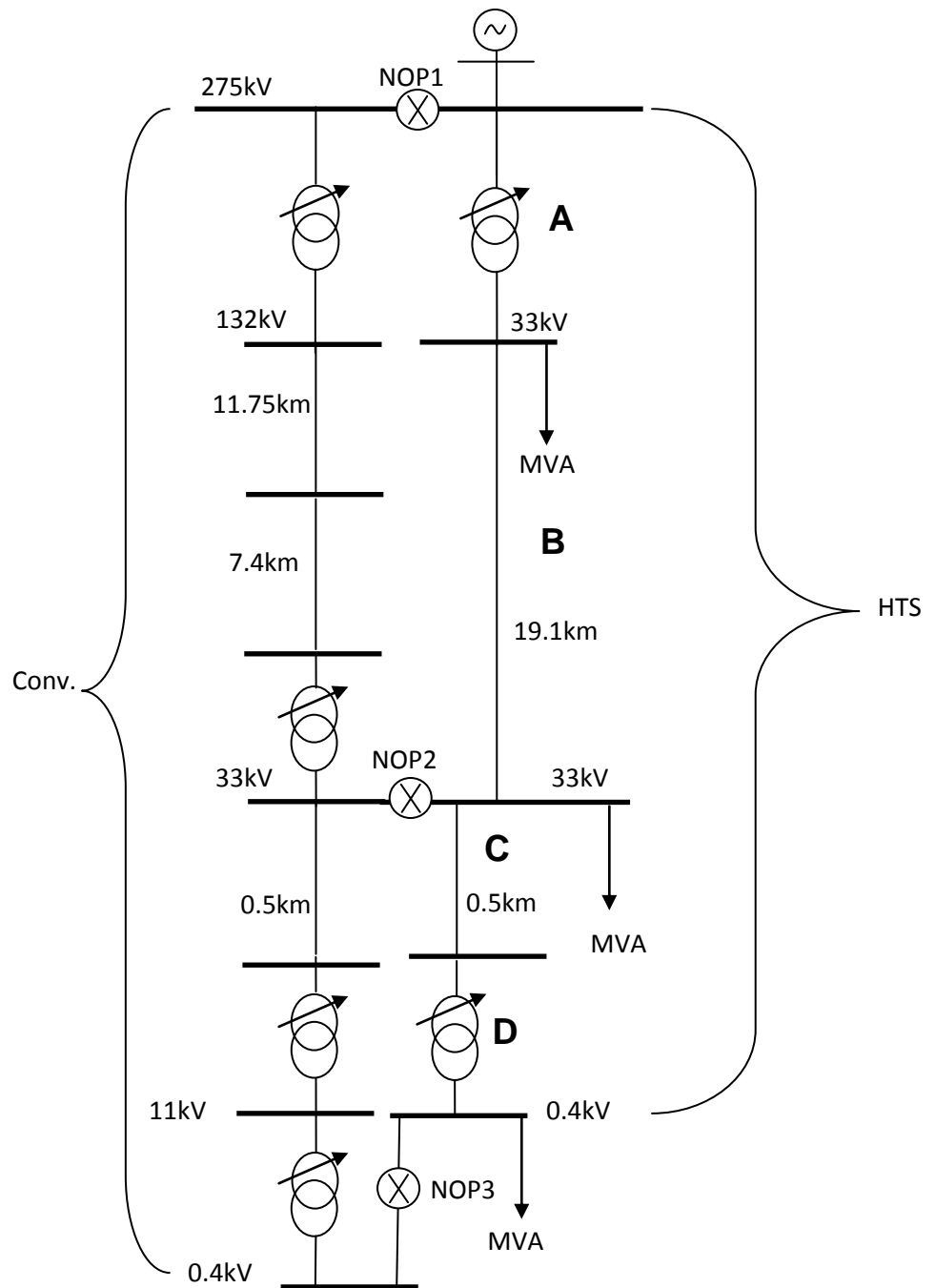

Figure 48: The superconductor case network study

### 6.7.1. Fault A

When fault occurs in zone A of the superconductor network, the NOP1 and NOP2 will be turned on and NOP3 will be kept off. The delivering power to all loads can be achieved by sharing between the superconductor network

and some parts of the conventional distribution network using NOP1 and NOP2 as shown in Figure 49.

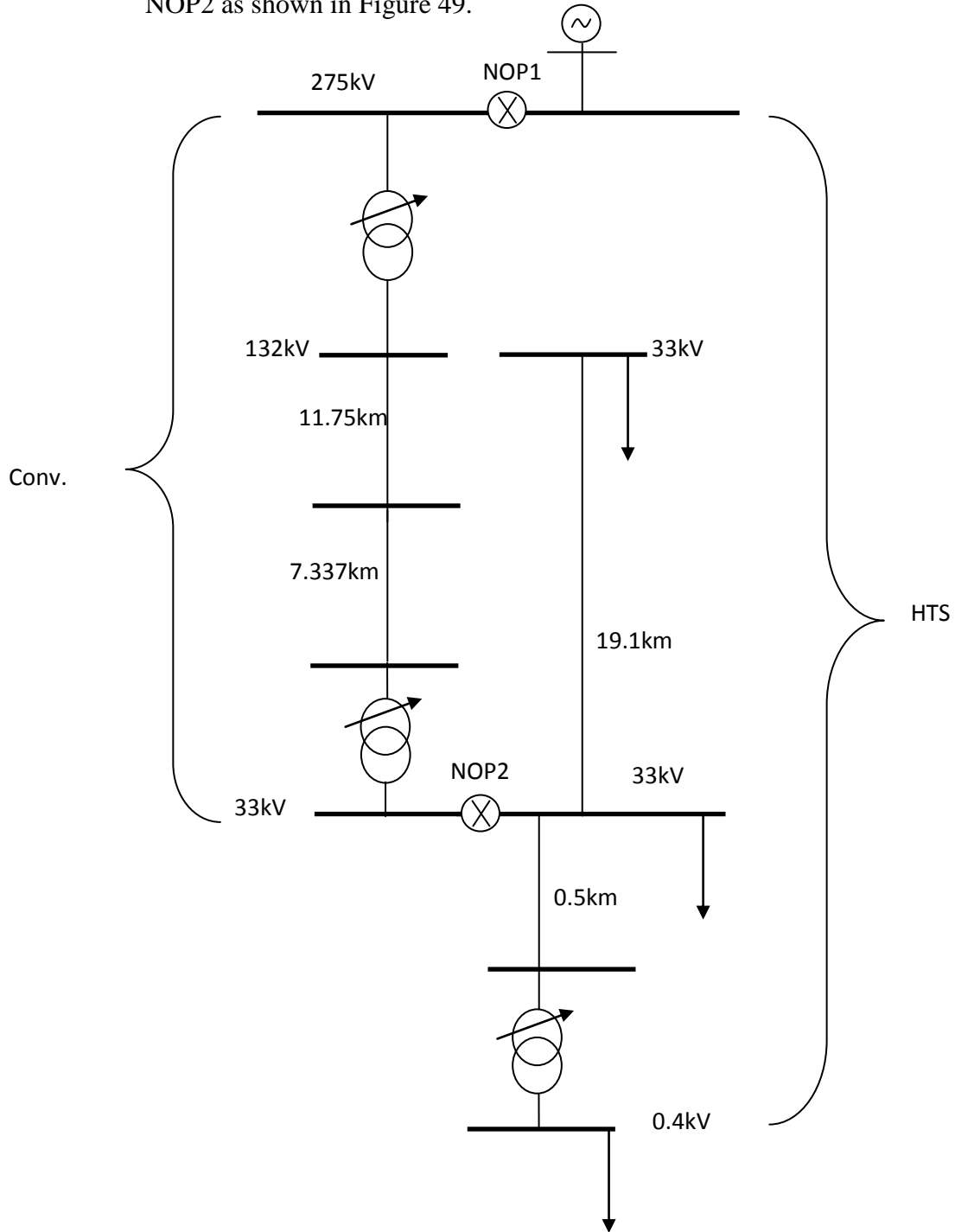

Figure 49: Zone A fault

### 6.7.2. Fault B

When a fault occurs in zone B of the superconductor network, NOP2 and NOP1 will be turned on and NOP3 will remain off. The delivery of power to all loads can be achieved by sharing between the superconductor and some

parts of the conventional distribution network using NOP2 and NOP1 as shown in Figure 50.

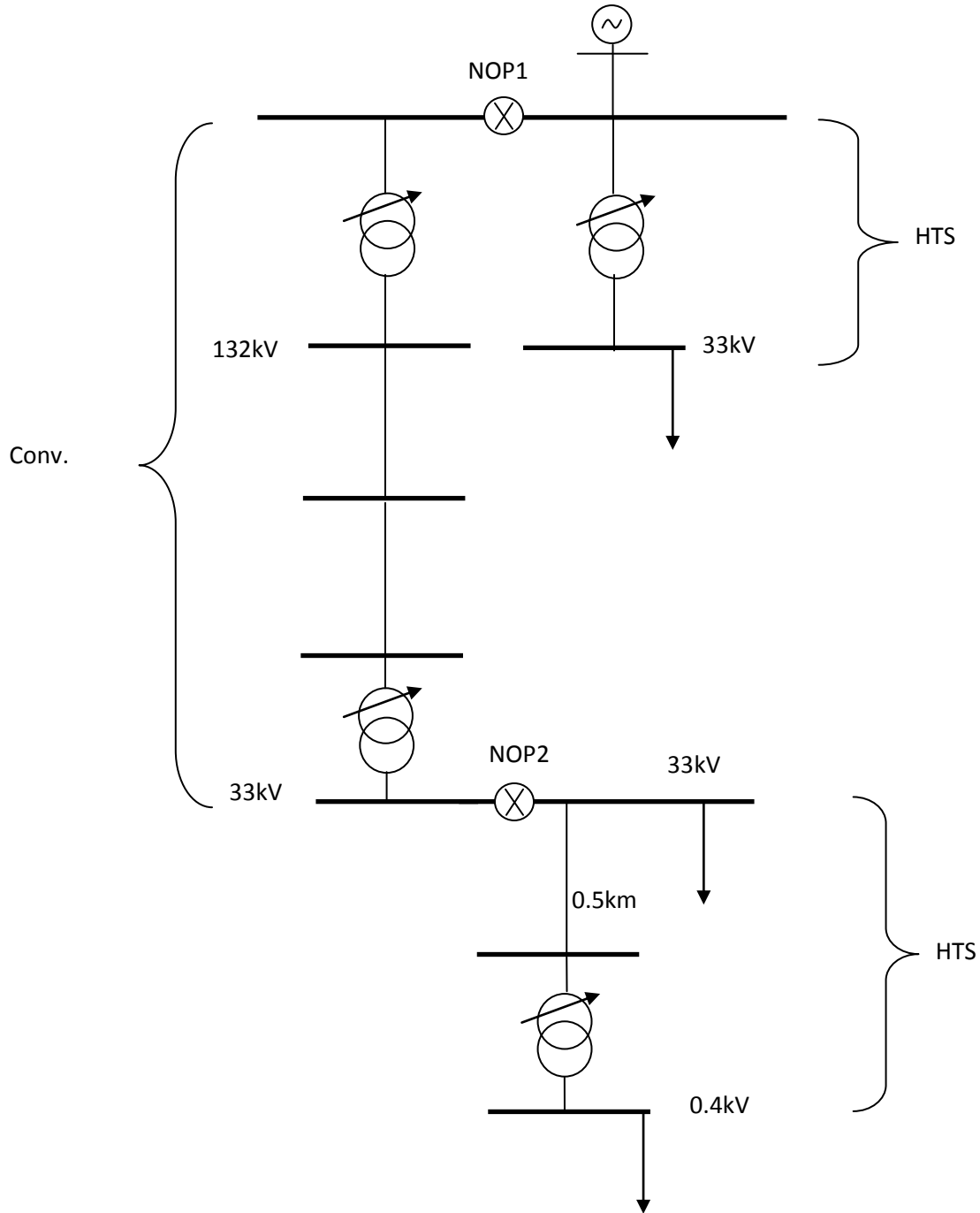

Figure 50: Zone B fault

### 6.7.3. Fault C or D

When the fault occurs in zone C or D of the superconductor network, the NOP3 will be turned on and other NOPs will remain off. The delivery of power to all loads can be achieved by sharing between the superconductor network and some parts of the conventional distribution network using NOP3 as shown Figure 51.

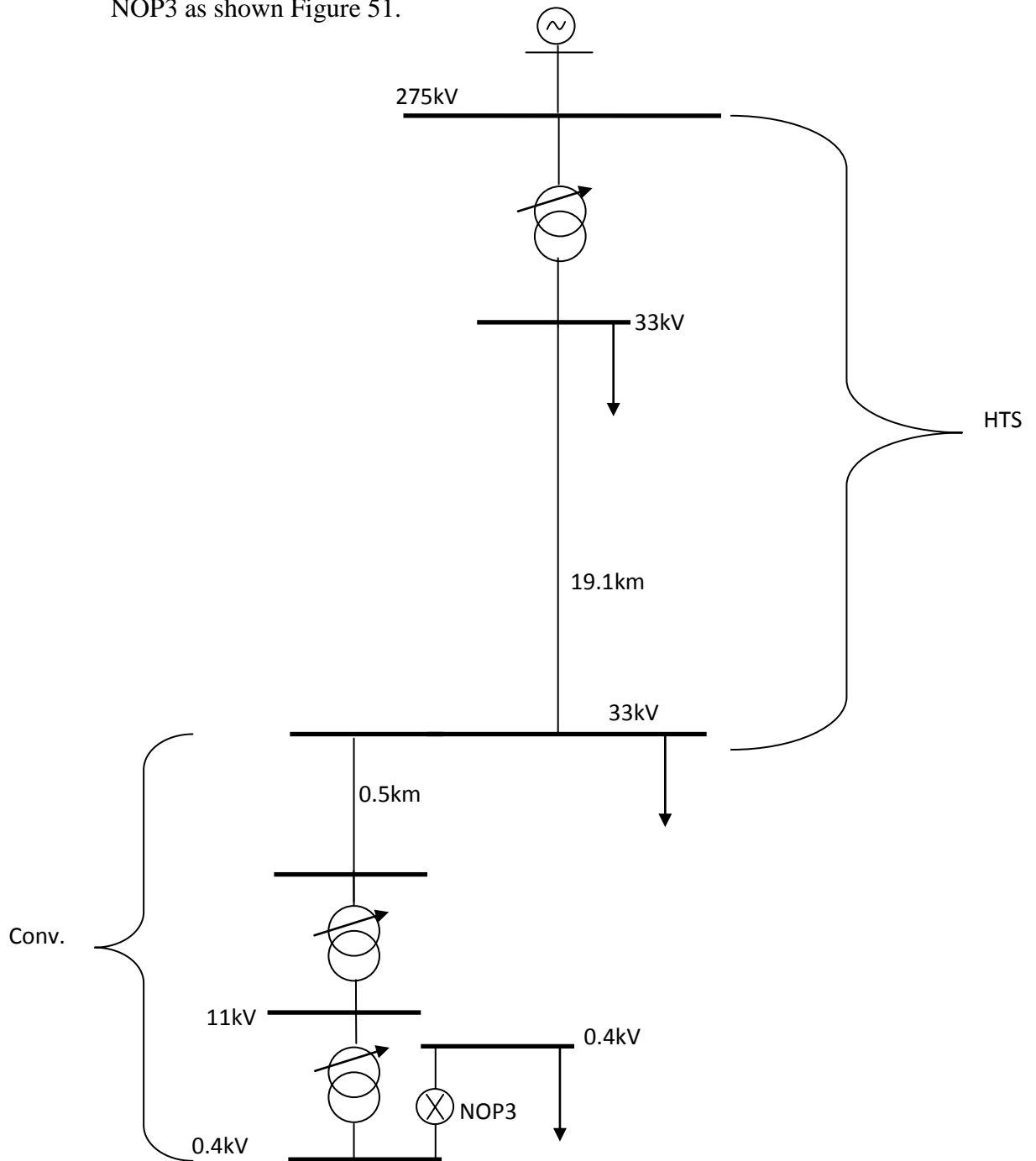

Figure 51: Zone C or D fault.

The total power loss in the proposed design for a 33kV superconductor distribution network, even when faults occur, have been calculated to demonstrate that the total power losses in the new design (figure 48) are still less than the existing conventional distribution network (figure 46) even when some parts of the conventional distribution network are sharing supplying power to loads within the 33kV superconductor network. The total power losses in the new design of the 33kV superconductor distribution network were different during fault operations (A, B, C or D) at peak demand. Table 22 compares power losses between the existing conventional distribution network and the new 33 kV superconductor distribution network design during different fault operations at peak demand.

Table 22 : The power losses comparisons

| Fault A or B |          | Fault C or D |          | Conventional network |          |
|--------------|----------|--------------|----------|----------------------|----------|
| P(MW)        | Q(MVArS) | P(MW)        | Q(MVArS) | P(MW)                | Q(MVArS) |
| 1.9292       | 4.4285   | 0.2334       | 0.41     | 2.142                | 4.8973   |

Based on results, the total power losses in the new 33 kV superconductor distribution network design (figure 48) were less than the conventional distribution network (figure 46) even during fault operations. The reason for the increased real power losses during faults in zones A or B is because the majority of the conventional distribution network was operated to share supplying power supply to all customers.

### **6.8. New 33 kV design of superconductor network - risk assessments**

The same assumptions for failure rates for HTS technologies have been used with this network as shown in tables 20 and 21. However, the risk assessment of conventional distribution networks needs to be included because this operates should a fault occur in the superconductor network to maintain power delivery to all customers.

#### **6.8.1. Calculation of event probability of customers losing power**

The same calculation for a 33 kV superconductor distribution network is used (figure 47); therefore the same result for this step is used (1.34).

#### **6.8.2. Calculate RC cost**

The same result is obtained from this step because CR has been done on only the superconductor distribution network:

$$CR = £20,000 \times 1.34 = £26.8k \text{ per year}$$

#### **6.8.3. Calculation of CI cost**

Assuming a unit CI cost of £5, and based on customer numbers of 8,000 over the whole network the same percentage for event probabilities of losing customers in conventional distribution network has been used (0.15 %) in this calculation. Therefore, the CI cost calculation is given by:

$$CI = 1.34 \times 0.15 \times £5 \times 8,000 = £8.2k \text{ per year}$$

#### **6.8.4. Calculation of RT and CML costs**

For CML, the same calculation is undertaken by multiplying the percentage probability of customers losing power as in conventional distribution network as shown below

$$\text{CML} = 1.34 \times 0.15 \times \text{£}10 \times 8,000 \times 0.8 = \text{£}12.9\text{k per year}$$

### 6.8.5. Calculation of TNR

$$\text{Total Network Risk (TNR)} = \text{CR} + \text{CI} + \text{CML} = \text{£}47.7\text{k per year}$$

The future design of the 33 kV superconductor distribution network (figure 48) has proved that the risk level and power losses could be lower than the risk level and power losses in the existing conventional distribution network (figure 46). However, the capital cost of these designs needs to be introduced to find out whether the capital cost of the new design will be less than the existing conventional distribution network in the future.

### 6.9. Capital cost comparisons

Based on table 6 and 7, (Chapter 2, P30 and P31), the capital cost for the proposed new design of a 33 kV superconductor distribution network (figure 48) in the future shows as follows:

Capital cost = the capital cost of conventional network + the capital cost of 33 kV superconductor distribution network when Bi-2 223 is 6.4 £/kAm = 23.3 + 20.1 = £43.4M and when Bi-2223 is 12.4£/kAm = 23.3 + 38.4 = £61M.

While the cost of the present conventional distribution network (figure 45) is £46.6 M.

If the whole network adopts this new design, the capital cost of a 33 kV superconductor distribution network will be as follows: Capital cost = 61.7 + 78.1 = £139.8M when Bi-2223 is 6.4 £/ kAm and when Bi-2223 is 12.4£/kAm = 109.2 + 78.1 = £187.3M.



While the capital cost for whole current design of the conventional network is £156.6M.

### **6.10. Summary**

This chapter has introduced a novel future design of 33kV superconductor distribution networks which can result in lower power losses, lower risk levels and lower capital cost than the existing conventional distribution network designs. The future 33kV superconductor network design (without applying a hybrid design) proposed results in figure 47, approximately 3 times higher risk levels than figure 46; the present conventional distribution network design. The risk level in the new design of figure 48; a 33kV superconductor distribution network (with applying a hybrid design) can be reduced by £5.8k events per a year from the risk level occurring in the present conventional distribution network design. Implementing a new 33kV superconductor distribution network design could save £16M from the capital cost of the current conventional network design. This study has shown that HTS assets have the opportunity to reduce power losses, risk levels and capital costs in distribution networks in the future (2030). Table 23 shows the summaries of the advantages of using the future 33kV hybrid superconducting distribution network in terms of reducing capital cost and risk level.

Table 23: The comparisons in total network risk and capital cost for the conventional and 33kV superconductor distribution network designs

| Network design                                                    | Capital cost | Total network risk |
|-------------------------------------------------------------------|--------------|--------------------|
| Conventional distribution network design                          | £156.6M      | £52.9k             |
| Future 33kV superconductor network without applying hybrid design | £61.7M       | £166.3k            |
| Future 33kV hybrid superconducting network design                 | £139.8M      | £47.7k             |

## **7. Conclusions and future work**

### **7.1. Conclusions**

This thesis has explored the possibility of the implementation of HTS technologies within distribution power systems. The research also has the potential to encourage utilities to implement HTS cables and HTS transformers into distribution and transmission power systems in order to improve their economic and environmental value. Furthermore, the implementation of HTS technologies could lead to several advantages such as enhancing the capability of distribution power systems to accommodate significant load growth, manage risk levels, reduce losses, reduce capital cost of distribution network, introduce new design and avoid voltage control issues. The main conclusions of this research are as follows:

#### **Power Losses**

This research implies that using HTS assets such as cables and transformers with larger distribution networks, which are operated with several voltage level networks, are more beneficial in terms of reducing power losses in the distribution systems. Chapter 6 showed that the cost of energy losses could be reduced by £57k a year using HTS assets with the larger case distribution network. However, applying HTS assets with the smaller 11kV distribution network, which operates at voltage level 11kV, could only reduce £7k of cost energy losses a year as demonstrated in chapter 4.

#### **Voltage Control**

Using HTS assets with distribution networks would overcome voltage drop issues, which would be faced by conventional distribution networks,

especially at peak and future demands. This research indicated that 6.6kV, 11kV and 20kV superconductor distribution networks would not have voltage drop issues at peak and future demands, and also would not need to operate with existing or additional conventional control equipment to maintain voltage within required limits.

### **Renewable Energy Integration**

This research showed that HTS assets can be implemented with MV distribution networks injecting more power from future renewable energies without causing any voltage regulation issues. This research demonstrated that 40MW can be delivered by future onshore wind farms in the 20kV superconductor distribution networks at minimum loads without causing any voltage regulation issues, while only 2.5MW can be delivered by future onshore wind farms in the 20kV conventional distribution networks under the same conditions.

### **Capital Costs**

The projected cost of HTS assets have assumed in this research. These costs have been investigated based on the present and projected prices of HTS materials and refrigeration systems, which are used to produce HTS technologies. This research estimates that the price of HTS cables will reach £0.96k/m by 2030 including refrigeration systems, while the total future price of HTS transformers will 10% higher than the total current price of conventional transformers by 2030. Consequently, this study could aid utilities to evaluate the possibility of applying HTS technologies with distribution.

### **Reactive Power Sharing**

This research introduced that sharing reactive power in the 11 kV superconductor power systems can be achieved using conventional methods and technologies. It was shown that the PMS method can be used with an 11 kV distribution network, when HTS cables and transformer are used, to share reactive power between distribution generators. However, when HTS technologies are implemented into distribution power systems, the accuracy of voltage measurements is very small compared with the accuracy of voltage measurements is in the conventional distribution network. For this reason, conventional equipment such as the AVR must be sufficiently accurate to detect the voltage ratio error in a network because the error will be smaller than that occurring in the conventional network. Digital AVRs represent one solution that could be used to detect a small voltage ratio error when HTS cables and transformers are used.

### **Power System Design**

This research demonstrates that using HTS assets with larger distribution networks, which are operated with intermediate voltage levels, are also more beneficial in terms of reducing capital cost in the distribution networks. The new design of the 33kV superconductor distribution network has shown that it has the ability to remove the intermediate voltage levels, which leads to a reduction in lower capital costs than those for conventional networks in the future. Moreover, implementing the 33kV superconductor network design in 2030 could save £95M on the capital cost of the current conventional network design. However, using HTS assets with a smaller distribution network, which operates at one voltage level, results in much

higher capital cost than the conventional cases. Chapter 5 showed the future capital cost of the smaller 20kV superconductor distribution network at £109.8M higher than a current capital cost of a 20kV conventional distribution network

### Network Risk

The use of a hybrid superconducting distribution network would reduce the risk in the network. This research demonstrated that implementing a future hybrid 33 kV superconducting distribution network could save £5.8k per a year from the risk level in the present conventional distribution network design. However, this needs to implement NOPs with any future design of a superconductor distribution network to switch off and on additional conventional distribution networks as and when needed.

A novel network design which utilises the attributes of superconducting network assets has been identified and presented in the conclusions to this thesis. Table 24 demonstrates the benefits and disadvantages of future superconducting network assets.

Table 24: The benefits and disadvantages of using HTS assets with distribution power systems.

| Network design                      | Conventional distribution network (CN)design | Future 33kV hybrid superconducting network (SCN) design | Different cost between SCN and CN designs |
|-------------------------------------|----------------------------------------------|---------------------------------------------------------|-------------------------------------------|
| Current capital cost (2013)         | £156.6M                                      | £998.7M                                                 | Higher £842.1M                            |
| Future capital cost (2030 )         | £156.6M                                      | £139.8M                                                 | Lower £16.8.8M                            |
| Cost of energy losses per year      | £224.5k                                      | £187.6k                                                 | Lower £57k                                |
| Cost of total network risk per year | £52.9k                                       | £47.7k                                                  | Lower £5.2k                               |

In 2013, the total cost of the 33kV hybrid superconductor distribution network design would be £842.1M higher than that of the present conventional distribution network design as shown in table 24. However, by 2030 the future 33kV superconductor network design will be £16.86 M lower than the present conventional network design. Consequently, these results show that using HTS assets in large distribution network design, operating at different voltage levels could save millions of pounds in the future.

The novelty of the work described in this thesis lays in the use of HTS assets into power systems to address the challenges and opportunities of using these technologies in the future. This research has concluded the beneficial and negative aspects of implementing superconductor assets into power systems to understand the suitable applications of using these requirements in power systems to address current and future issues which are faced by conventional power systems. Superconductor technologies would be one of the key technologies this century and the costs of HTS asset systems are accepted to reduce through wider market access.

## **7.2. Future Work**

The current research has mainly focused on the advantages that can be gained when applying AC HTS technologies with transmissions and distribution power systems. Few studies have carried out research to apply DC HTS technologies to transmission systems. Further research and investigation is still required in order to implement DC HTS technologies to distribution and transmission power systems. Several areas which could be investigated from the current research have been identified as follows:

1. From this research, the price of HTS cables and transformers would be economically feasible to implement in power systems by 2016 – 2020 which will be suitable to apply to the future UK Round 3 offshore wind farms that will operate in 2020. DC HTS cables can be implemented in the future with future UK Round 3 offshore wind farms to deliver a large amount of power (GVA) over long distances (km), therefore research in this area needs to be carried out as follows:

- I. Determine the suitable voltage level that can be operated with future DC HTS transmission power systems for UK Round 3 offshore wind farms in order to reduce costs of substations such as transformers and converters.
- II. DC HTS cables are brittle, therefore how can they deliver power as submarine cables?

2. Applying DC HTS cables with urban areas where distribution networks exist is another opportunity for using DC HTS cables. Therefore, further research needs to be carried out as follows:

- I. Which application of DC HTS cables is suitable for applying with DC distribution networks?



## References

- [1] L. Ramesh, S. Chowdhury, S. Chowdhury, A. Natarajan, and C. Gaunt, "Minimization of Power Loss in Distribution Networks by Different Techniques," *International Journal of Electrical Power and Energy Systems Engineering*, vol. 2, 2009.
- [2] A need for smart energy demand and supply. Available: IBM Smart Energy–Overview–United–Kingdom,2012.  
[http://www.ibm.com/smarterplanet/uk/en/smart\\_grid/ideas/index.html](http://www.ibm.com/smarterplanet/uk/en/smart_grid/ideas/index.html)
- [3] R. Smith, "UK Future Energy Scenarios:NationalGrid, " NationalGrid2011.
- [4] C. Masters, "Voltage rise: the big issue when connecting embedded generation to long 11 kV overhead lines," *Power Engineering Journal*, vol. 16, pp. 5-12, 2002.
- [5] M. N. Marwali, J. W. Jung, and A. Keyhani, "Control of distributed generation systems-Part II: Load sharing control," *Power Electronics, IEEE Transactions on*, vol. 19, pp. 1551-1561, 2004.
- [6] K. Thyagarajan, A. Davari, and A. Feliachi, "Load sharing control in distributed generation system," *Proceedings of the Thirty-Seventh southeastemymposium on System theroy*, pp. 424-428,2005.
- [7] T. L. Vandoorn, B. Renders, B. Meersman, L. Degroote, and L. Vandevelde, "Reactive power sharing in an islanded microgrid,"*Presented at the 45<sup>th</sup> int,University Power Engineering Conf,Cardiff* , pp. 1-6.2010.
- [8] P. Kundur, N. J. Balu, and M. G. Lauby, *Power system stability and control* vol. 4: McGraw-hill New York, 1994.
- [9] J. Andruszkiewicz, J. Lorenc, and K. Marszalkiewicz, "Influence zones and disturbance levels in LV and MV distribution network in result of supply of industrial welder lines equipped with power conditioner," *Electricity Distribution, 2005. CIRED 2005. 18th International Conference and Exhibition on*, pp. 1-42005
- [10] D. M. Cao, D. Pudjianto, G. Strbac, R. Ferris, I. Foster, and M. Aten, "Examination of the impact of possible distribution network design on network losses," *Electricity Distribution - Part 1, 2009. CIRED 2009. 20th International Conference and Exhibition on*, pp. 1-4, 2009.

- [11] S. Curcic, G. Strbac, and X. P. Zhang, "Effect of losses in design of distribution circuits," *Generation, Transmission and Distribution, IEE Proceedings*, pp. 343-349, 2001.
- [12] Y. M. Yamada, M. Sato, K., "Examples and Future Prospects of High-Temperature Superconductor Products," *SEI -Technical Review* vol. 65, p. 51, 2007.
- [13] W. V. Hassenzahl, "Applications of superconductivity to electric power systems," *Power Engineering Review, IEEE*, vol. 20, pp. 4-7, 2000.
- [14] The Crown Estate Round3 Offshore Wind Farms has a good Webpage for citing web sources is available on <http://www.thecrownestate.co.uk/news-media/news/2012/first-planning-application-submitted-for-round-3-offshore-wind-programme/>, 2012
- [15] D. Lane, "Round 3 offshore wind farm connection study," Nation Grid 2008.
- [16] G. Vidali, *Superconductivity: the next revolution?*: Cambridge Univ Pr, 1993.
- [17] P. J. Ford and G. A. Saunders, *The rise of the superconductors*: CRC, 2005.
- [18] P. M. Grant, "Superconductivity and electric power: promises, promises... past, present and future," *Applied Superconductivity, IEEE Transactions on*, vol. 7, pp. 112-133, 1997.
- [19] Theory of High Temperature Superconductor materials .Available on <http://web.mit.edu/newsoffice/2013/new-look-at-high-temperature-superconductors-0224.html> by Massachusetts Institute of Technology. 2013
- [20] J. O. Willis, "Superconducting transmission cables," *Power Engineering Review, IEEE*, vol. 20, pp. 10-14, 2000.
- [21] J. R. Bumby, *Superconducting rotating electrical machines*: Clarendon Press, 1983.
- [22] L. Lawrence, C. Cox, and D. Broman, "High temperature superconductivity: the products and their benefits," *Bob Lawrence & Associates, Inc., Alexandria, VA, Rep. ORNL/Sub/97-SX339V/2*, 1998.
- [23] E. Forsyth, "Superconducting power transmission systems-the past and possibly the future," *Superconductor Science and Technology*, vol. 6, p. 699, 1993.

- [24] B. Belanger, "Superconducting power transmission programme in the USA," *Cryogenics*, vol. 15, pp. 88-90, 1975.
- [25] Second generation HTS wire for high-current cable and power-dense coil applications. Available on, [http://www.amsc.com/solutions-products/hts\\_wire.html](http://www.amsc.com/solutions-products/hts_wire.html)). 2012.
- [26] R. A. Hawsey and S. Morozumi, "The Energy and Environmental Benefits of Superconducting Power Products," *Mitigation and Adaptation Strategies for Global Change*, vol. 10, pp. 279-306, 2005.
- [27] D. U. Gubser, "Superconductivity: an emerging power-dense energy-efficient technology," *Applied Superconductivity, IEEE Transactions on*, vol. 14, pp. 2037-2046, 2004.
- [28] N. Steve, M. Nassi, M. Bechis, P. Ladič, N. Kelley, and C. Wakefield, "High temperature superconducting cable field demonstration at Detroit Edison," *Physica C: Superconductivity*, vol. 354, pp. 49-54, 2001.
- [29] Carrollton, Georgia HTS Triax Project, Available on <http://www.supercables.com/carrollton.html>, 2009
- [30] J. Maguire and J. Yuan, "Status of high temperature superconductor cable and fault current limiter projects at American Superconductor," *Physica C: Superconductivity*, vol. 469, pp. 874-880, 2009.
- [31] H. Xi, W. Gong, Y. Zhang, Y. Bi, H. Ding, H. Wen, B. Hou, and Y. Xin, "China's 33.5 m, 35kV/2kA HTS ac power cable's operation in power grid," *Physica C: Superconductivity*, vol. 445, pp. 1054-1057, 2006.
- [32] T. Masuda, H. Yumura, M. Ohya, T. Kikuta, M. Hirose, S. Honjo, T. Mimura, Y. Kito, K. Yamamoto, and M. Ikeuchi, "A new HTS cable project in Japan," *Applied Superconductivity, IEEE Transactions on*, vol. 19, pp. 1735-1739, 2009.
- [33] A. Geschiere, D. Willen, I. Melnik, E. Piga, and P. Barendregt, "Efficient upgrading of distribution networks with HTS cables," in *Electricity Distribution - Part 1, 2009. CIREN 2009. 20th International Conference and Exhibition on*, 2009, pp. 1-3.
- [34] M. Stemmler, "Medium voltage superconductor cable systems for inner city power supply," presented at the Second seminar on Undergrounding of electric Distribution Networks 8-10 November, Alagoas, Brazil., 2011.

- [35] Y. Choi, D. Kim, H. Yang, S. Sohn, J. Lim, and S. Hwang, "Progress on the Performance Test of KEPCO HTS Power Cable," *Applied Superconductivity, IEEE Transactions on*, pp. 1-1, 2011.
- [36] I. Sauers, D. R. James, A. R. Ellis, E. Tuncer, M. O. Pace, M. J. Gouge, J. A. Demko, and D. Lindsay, "High voltage testing of a 5-meter prototype triaxial HTS cable," *Applied Superconductivity, IEEE Transactions on*, vol. 17, pp. 1734-1737, 2007.
- [37] C. Weber, R. Lee, S. Ringo, T. Masuda, H. Yumura, and J. Moscovic, "Testing and demonstration results of the 350 m long HTS cable system installed in Albany, NY," *Applied Superconductivity, IEEE Transactions on*, vol. 17, pp. 2038-2042, 2007.
- [38] T. Masuda, H. Yumura, M. Watanabe, H. Takigawa, Y. Ashibe, C. Suzawa, T. Kato, K. Okura, Y. Yamada, and M. Hirose, "High-temperature superconducting cable technology and development trends," *SEI Technical Review*, vol. 59, p. 13, 2005.
- [39] T. Masuda, H. Yumura, M. Ohya, Y. Ashibe, M. Watanabe, T. Minamino, H. Ito, S. Honjo, T. Mimura, and Y. Kitoh, "Test results of a 30 m HTS cable for Yokohama project," *Applied Superconductivity, IEEE Transactions on*, pp. 1-1, 2011.
- [40] Superconducting Power Equipment : Technology Watch 2011," EPRI, Report 2011 1021890.
- [41] S.Eckorad. Superconducting Power Cables. Electric power research in institute,2009
- [42] A,Geschiere "Long distance Triax HTS cable, " *Presented at the CIRED ,19th International Conference on Electricity Distribution ,Vienna,21-24 May 2007.*
- [43] G. J. Lee, "Superconductivity Application in Power System."Available on ,[http://cdn.intechopen.com/pdfs/16185/InTechSuperconductivity\\_application\\_in\\_power\\_system.pdf](http://cdn.intechopen.com/pdfs/16185/InTechSuperconductivity_application_in_power_system.pdf),2000.
- [44] A. Geschiere, D. Willén, E. Piga, and P. Barendregt, "HTS cables open the window for large-scale renewables," *Jour. of Phys.: Conference Series* ,2008, p. 012183.
- [45] J. Yoon and S. Lee, "Step-by-step application methodology in practical KEPCO 22.9 kV bus-bar system," *9th European Conference on Applied Superconductivity*, p. 032066,2010.

- [46] X. Chen and J. Jin, "Development and technology of HTS transformers," *Research Communication*, vol. 1, pp. 2.1-2.7, 2007.
- [47] C. Weber, C. Reis, D. Hazelton, S. Schwenterly, M. Cole, J. Demko, E. Pleva, S. Mehta, T. Golner, and N. Aversa, "Design and operational testing of a 5/10-MVA HTS utility power transformer," *Applied Superconductivity, IEEE Transactions on*, vol. 15, pp. 2210-2213, 2005.
- [48] C. T. Reis, S. P. Mehta, B. W. McConnell, and R. H. Jones, "Development of high temperature superconducting power transformers," *In Power Engineering Society Winter Meeting, IEEE*, vol. 2, pp. 432-437, 2001.
- [49] X. Y. C. a. J. X. Jin, "Development of HTS transformers and a 10 kVA HTS transformer prototype design," *Journal of electronic science and technology in China*, vol. 6, pp. 130-136, 2008,
- [50] Y. Wang, X. Zhao, J. Han, H. Li, Y. Guan, Q. Bao, L. Xiao, L. Lin, X. Xu, and N. Song, "Development of a 630 kVA three-phase HTS transformer with amorphous alloy cores," *Applied Superconductivity, IEEE Transactions on*, vol. 17, pp. 2051-2054, 2007.
- [51] H. Zueger, "630kVA high temperature superconducting transformer," *Cryogenics*, vol. 38, pp. 1169-1172, 1998.
- [52] S. H. Kim, W. S. Kim, K. D. Choi, H. G. Joo, G. W. Hong, J. H. Han, H. G. Lee, J. H. Park, H. S. Song, and S. Hahn, "Characteristic tests of a 1 MVA single phase HTS transformer with concentrically arranged windings," *Applied Superconductivity, IEEE Transactions on*, vol. 15, pp. 2214-2217, 2005.
- [53] C. Lee and B. Y. Soek, "Design of the 3 phase 60 MVA HTS transformer with YBCO coated conductor windings," *Applied Superconductivity, IEEE Transactions on*, vol. 15, pp. 1867-1870, 2005.
- [54] S. Lee, S. Byun, W. Kim, J. Lee, and K. Choi, "Design of a single phase 33 MVA HTS transformer with OLTC," *Applied Superconductivity, IEEE Transactions on*, vol. 17, pp. 1939-1942, 2007.
- [55] J. Choi, S. Lee, M. Park, W. Kim, S. Kim, J. Han, H. Lee, and K. Choi, "Design of 154kV class 100MVA 3 phase HTS transformer on a common magnetic core," *Physica C: Superconductivity*, vol. 463, pp. 1223-1228, 2007.
- [56] T. Bohno, A. Tomioka, M. Imaizumi, Y. Sanuki, T. Yamamoto, Y. Yasukawa, H. Ono, Y. Yagi, and K. Iwate, "Development of 66kV/6.9 kV 2MVA prototype HTS power transformer," *Physica C: Superconductivity*, vol. 426, pp. 1402-1407, 2005.

- [57] R. Schlosser, H. Schmidt, M. Leghissa, and M. Meinert, "Development of high-temperature superconducting transformers for railway applications," *Applied Superconductivity, IEEE Transactions on*, vol. 13, pp. 2325-2330, 2003.
- [58] L. J. Masur, J. Kellers, F. Li, S. Fleshler, and E. R. Podtburg, "Industrial high temperature superconductors: perspectives and milestones," *Applied Superconductivity, IEEE Transactions on*, vol. 12, pp. 1145-1150, 2002.
- [59] A. Malozemoff, B. Kehrl, J. Diazdeleon, and S. Kalsi, "Superconducting technologies for a controllable and reliable high capacity grid," IEEE PES Power systems Conf,Expositions,New York,Oct.10-13, p. 2276 Vol. 2,2004.
- [60] L. Masur, D. Buczek, E. Harley, T. Kodenkandath, X. Li, J. Lynch, N. Nguyen, M. Rupich, U. Schoop, and J. Scudiere, "The status of commercial and developmental HTS wires," *Physica C: Superconductivity*, vol. 392, pp. 989-997, 2003.
- [61] S. R. E, Ettetdgui ,A,Hove, "Strengthening the grid:Effect of high-temperature superconducting power technologies on reliability, power transfer capacity and energy use," RAND Corp.Sci. Technol. Policy Inst. Rep.2000.
- [62] A. P. Malozemoff, "The new generation of superconductor equipment for the electric power grid," *Applied Superconductivity, IEEE Transactions on*, vol. 16, pp. 54-58, 2006.
- [63] Z. Han and X. Hu, "Power application of superconductivity technology in China," *Superconductor Science and Technology*, vol. 19, p. S109, 2006.
- [64] P. M. Grant and T. P. Sheahen, "Cost projections for high temperature superconductors," *Arxiv preprint cond-mat/0202386*, 2002.
- [65] B. W. M. J. A. D. M. J. Gouge, and J. M. Pfothenhaure, "Cryogenic Assessment Report," Oak Ridge National Laboratory Report, 2002.
- [66] M. Clayton, "No more power lines? Buried super-cooled electrical cables may replace towering transmission lines and carry solar and wind energy efficiently over long distances," *American superconductor Science and Technology*, December 31, 2009.
- [67] S. P. Mehta, N. Aversa, and M. S. Walker, "Transforming transformers [superconducting windings]," *Spectrum, IEEE*, vol. 34, pp. 43-49, 1997.
- [68] The information for Superconductor transformors , Avaliable on <http://www.csanyigroup.com/superconducting-transformers>.

- [69] H. Jones, "Superconductors in the transmission of electricity and networks," *Energy Policy*, vol. 36, pp. 4342-4345, 2008.
- [70] Z. Chen, "Issues of connecting wind farms into power systems," *Transmission and Distribution Conference and Exhibition: Asia and Pacific, IEEE/PES*, pp. 1-6, 2005.
- [71] T. Ackermann, "Wind power in power systems," *Wind Engineering*, vol. 30, pp. 447-449, 2006.
- [72] J. Arrillaga, "High voltage direct current transmission", vol. 29: Iet, 1998.
- [73] M. Merlin, T. Green, P. Mitcheson, D. Trainer, D. Critchley, and R. Crookes, "A new hybrid multi-level voltage-source converter with DC fault blocking capability," in *AC and DC Power Transmission, 2010. ACDC. 9th IET International Conference on*, pp. 1-5, 2010.
- [74] N. B. Negra, J. Todorovic, and T. Ackermann, "Loss evaluation of HVAC and HVDC transmission solutions for large offshore wind farms," *Electric Power Systems Research*, vol. 76, pp. 916-927, 2006.
- [75] S. K. Olsen, O. Tonnesen, and J. Ostergaard, "Power applications for superconducting cables in Denmark," *Applied Superconductivity, IEEE Transactions on*, vol. 9, pp. 1285-1288, 1999.
- [76] J. McCall, B. Gamble, and S. Eckroad, "Long Distance Transmission System Using VSC HVDC Terminals and Superconductors for Bulk Transport of Renewable Energy," *Presented at the CIGRE Conference on Power Systems*, Toronto, Canada, Oct. 4-6, 2009.
- [77] J. Jin, J. Zhang, Y. Guo, Y. Zhan, and J. Zhu, "Next generation of DC power transmission technology using High Tc superconducting cables," *Curtin University of Technology*, pp. 1-6, 2007.
- [78] J. X. Jin, "High efficient dc power transmission using high-temperature superconductors," *Physica C: Superconductivity*, vol. 460, pp. 1443-1444, 2007.
- [79] J. Zhang and J. Jin, "Simulation analysis of DC power transmission using high Tc superconducting cables," *Industrial Technology, IEEE*, pp. 1-4, 2008.
- [80] J. X. Jin and Q. Huang, "High-Temperature Superconductor DC Power Transmission," *IEEE Trans. Appl. Superconpercon*, vol. 101, p. 1, 2005.

- [81] B. W. McConnell, "Applications of high temperature superconductors to direct current electric power transmission and distribution," *Applied Superconductivity, IEEE Transactions on*, vol. 15, pp. 2142-2145, 2005.
- [82] M. Furuse, S. Fuchino, N. Higuchi, and I. Ishii, "Feasibility study of low-Voltage DC Superconducting distribution system," *Applied Superconductivity, IEEE Transactions on*, vol. 15, pp. 1759-1762, 2005.
- [83] S. Yamaguchi, M. Hamabe, A. Sasaki, I. Yamamoto, F. Tosin, K. Matsui, M. Yukimoto, E. Mizuno, K. Yamada, and A. Iiyoshi, "A proposal for DC superconducting power transmission Line," *IEEE Trans. Appl. Supercond.*
- [84] Y. Miura, R. Sato, M. Saisho, and T. Ise, "DC Loop Type Superconducting Distribution System Including Various Distributed Generations," *Applied Superconductivity, IEEE Transactions on*, vol. 17, pp. 2335-2338, 2007.
- [85] G. Venkataramanan and B. K. Johnson, "A superconducting DC transmission system based on VSC transmission technologies," *Applied Superconductivity, IEEE Transactions on*, vol. 13, pp. 1922-1925, 2003.
- [86] P. M. Grant, "Superconducting Lines for the Transmission of Large Amounts of Electrical Power Over Great Distances: Garwin&#x2013;Matisoo Revisited Forty Years Later," *Applied Superconductivity, IEEE Transactions on*, vol. 17, pp. 1641-1647, 2007.
- [87] D. Salomonsson and A. Sannino, "Low-Voltage DC Distribution System for Commercial Power Systems With Sensitive Electronic Loads," *Power Delivery, IEEE Transactions on*, vol. 22, pp. 1620-1627, 2007.
- [88] P. Chowdhuri, C. Pallem, J. A. Demko, and M. J. Gouge, "Feasibility of electric power transmission by DC superconducting cables," *Applied Superconductivity, IEEE Transactions on*, vol. 15, pp. 3917-3926, 2005.
- [89] T. Weizhong and R. H. Lasseter, "An LVDC industrial power distribution system without central control unit," in *Power Electronics Specialists Conference, 2000. PESC 00. 2000 IEEE 31st Annual*, pp. 979-984 vol.2, 2000.
- [90] B. K. Johnson, R. H. Lasseter, F. L. Alvarado, D. M. Divan, H. Singh, M. C. Chandorkar, and R. Adapa, "High-temperature superconducting DC networks," *Applied Superconductivity, IEEE Transactions on*, vol. 4, pp. 115-120, 1994.
- [91] B. K. Johnson, R. H. Lasseter, F. L. Alvarado, and R. Adapa, "Expandable multiterminal DC systems based on voltage droop," *Power Delivery, IEEE Transactions on*, vol. 8, pp. 1926-1932, 1993.



- [92] B. K. Johnson, J. M. Appikonda, and G. Venkataramanan, "Reactive Compensation Needs for Superconducting Transmission Systems," *Applied Superconductivity, IEEE Transactions on*, vol. 19, pp. 2066-2069, 2009.
- [93] L. Seung Ryul, K. Jongyul, Y. Jae-young, and L. Byongjun, "Concept Design of Superconducting Power System Applying Distributed Switching Stations for the Metropolitan Area," *Applied Superconductivity, IEEE Transactions on*, vol. 19, pp. 2057-2061, 2009.
- [94] H. J. Kim and K. Hur, "Expanded Adoption of HTS Cables in a Metropolitan Area and its Potential Impact on the Neighboring Electric Power Grid," *Applied Superconductivity, IEEE Transactions on*, vol. 22, pp. 5800704-5800704, 2012.
- [95] D. Politano, M. Sjostrom, G. Schnyder, and J. Rhyner, "Technical and economical assessment of HTS cables," *Applied Superconductivity, IEEE Transactions on*, vol. 11, pp. 2477-2480, 2001.
- [96] Y. Jae-young, K. Jong-yeul, and L. Seung-yeol, "Application methodology of 22.9 kV HTS cable in metropolitan city of South Korea," in *Power Engineering Society General Meeting, 2004. IEEE*, pp. 23-27 Vol.1,2004.
- [97] K. C. Seong, S. B. Choi, J. W. Cho, H. J. Kim, Y. K. Kwon, K. S. Ryu, B. T. Kim, and I. K. Yu, "A study on the application effects of HTS power cable in Seoul," *Applied Superconductivity, IEEE Transactions on*, vol. 11, pp. 2367-2370, 2001.
- [98] J. A. Demko, J. W. Lue, M. J. Gouge, J. P. Stovall, Z. Butterworth, U. Sinha, and R. L. Hughey, "Practical AC loss and thermal considerations for HTS power transmission cable systems," *Applied Superconductivity, IEEE Transactions on*, vol. 11, pp. 1789-1792, 2001.
- [99] H. Fengnian and W. Wu, "Analysis of LN<sub>2</sub> cooling system and electrical insulation contraction for high T<sub>c</sub> superconducting cables," *Power Delivery, IEEE Transactions on*, vol. 14, pp. 743-749, 1999.
- [100] C. Matheus, H. J. Haubrich, and D. Willen, "Superconducting cables as a new option in network planning," in *Power Tech, 2005 IEEE Russia*, pp. 1-7,2005.
- [101] C. Matheus, H. J. Haubrich, D. Willen, W. Heuken, and R. Fischer, "Industrial distribution networks with superconducting cables," in *Future Power Systems, 2005 International Conference on*, pp. 6 pp.-6,2005.
- [102] D. Willen, C. Matheus, D. Lindsay, and M. Gouge, "The application of triaxial high-temperature superconducting power cables in distribution networks," in *Electricity Distribution, 2005. CIRED 2005. 18th International Conference and Exhibition on*, pp. 1-4,2005.

- [103] L. Ren, Y. Tang, J. Shi, L. Li, J. Li, and S. C. Cheng, "Techno-Economic Feasibility Study on HTS Power Cables," *Applied Superconductivity, IEEE Transactions on*, vol. 19, pp. 1774-1777, 2009.
- [104] A. A. Chowdhury, S. K. Agarwal, and D. O. Koval, "Reliability modeling of distributed generation in conventional distribution systems planning and analysis," *Industry Applications, IEEE Transactions on*, vol. 39, pp. 1493-1498, 2003.
- [105] A. L. Devi and B. Subramanyam, "Optimal DG unit placement for loss reduction in radial distribution system-a case study," *ARPJ Journal Engineering and Applied Sciences*, vol. 2, 2007.
- [106] M. Kashem, A. D. T. Le, M. Negnevitsky, and G. Ledwich, "Distributed generation for minimization of power losses in distribution systems," in *Proc. IEEE PES General Meeting*, p. 8 pp, 2006.
- [107] T. Vinnal, K. Janson, H. Kalda, and L. Kütt, "Analyses of supply voltage quality, power consumption and losses affected by shunt capacitors for power factor correction," in *Electric Power Quality and Supply Reliability Conference (PQ), Kuressaare*, pp. 53-60, 2010.
- [108] A. Augugliaro, L. Dusonchet, S. Favuzza, and E. R. Sanseverino, "Voltage regulation and power losses minimization in automated distribution networks by an evolutionary multiobjective approach," *Power Systems, IEEE Transactions on*, vol. 19, pp. 1516-1527, 2004.
- [109] T. Vinnal, K. Janson, and H. Kalda, "Analysis of power consumption and losses in relation to supply voltage quality," *13th Conference EPE 2009, Barcelona*, pp. 1-9, 2009.
- [110] C. L. T. Borges and D. M. Falcao, "Impact of distributed generation allocation and sizing on reliability, losses and voltage profile," in *Proc. IEEE/Power Engineering Society Power Tech Conf*, p. 5 pp. Vol. 2, 2003.
- [111] R. E. Brown and L. Freeman, "Analyzing the reliability impact of distributed generation," in *Proc. IEEE Power Eng. Soc. Summer Meeting*, vol. 2, pp. 1013-1018, 2001.
- [112] W. V. Hassenzahl, D. W. Hazelton, B. K. Johnson, P. Komarek, M. Noe, and C. T. Reis, "Electric power applications of superconductivity," *Proceedings of the IEEE*, vol. 92, pp. 1655-1674, 2004.

- [113] S.-H. Lim, H.-S. Choi, D.-C. Chung, Y.-H. Jeong, Y.-H. Han, T.-H. Sung, and B.-S. Han, "Fault current limiting characteristics of resistive type SFCL using a transformer," *Applied Superconductivity, IEEE Transactions on*, vol. 15, pp. 2055-2058, 2005.
- [114] M. Noe and B. Oswald, "Technical and economical benefits of superconducting fault current limiters in power systems," *Applied Superconductivity, IEEE Transactions on*, vol. 9, pp. 1347-1350, 1999.
- [115] M. Noe and M. Steurer, "High-temperature superconductor fault current limiters: concepts, applications, and development status," *Superconductor Science and Technology*, vol. 20, p. R15, 2007.
- [116] J. X. Jin, "Application of high temperature superconductors in DC power transmission systems," *Proceedings of Australasian Universities Power Engineering Conference*, pp. 626-628, 2005.
- [117] S. Cole, D. Van Hertem, L. Meeus, and R. Belmans, "Technical developments for the future transmission grid," *IEEE, International Conference on future power systems*. pp. 6, 2005
- [118] H. Wang and M. Redfern, "The advantages and disadvantages of using HVDC to interconnect AC networks," *Universities Power Engineering Conference (UPEC), 2010 45th International*, pp. 1-5, 2010.
- [119] J. Kreusel and D. Retzmann, "Integrated AC/DC Transmission Systems—Benefits of Power Electronics for Security and Sustainability of Power Supply," *Power System Computation Conference*, 2008, UK.
- [120] P. Naidoo, D. Muftic, and N. Ijumba, "Investigations into the upgrading of existing HVAC power transmission circuits for higher power transfers using HVDC technology," *Electric Power Systems Research, 2006 - Elsevier*, pp. 139-142, 2005.
- [121] Z. Jinhua, "Research on centralized and coordinate controls of multiple HVDC systems in China," *Transmission and Distribution Conference and Exposition, IEEE PES*, pp. 1-5, 2010.
- [122] S. Meier, S. Norrga, and H. P. Nee, "New voltage source converter topology for HVDC grid connection of offshore wind farms," in *Proc. EPE-PEMC*, Riga, Latvia, Sep. 2–4, 2004.

- [123] C. H. Chien and R. W. G. Bucknall, "Analysis of harmonics in subsea power transmission cables used in VSC–HVDC transmission systems operating under steady-state conditions," *Power Delivery, IEEE Transactions on*, vol. 22, pp. 2489-2497, 2007.
- [124] A. Reidy and R. Watson, "Comparison of VSC based HVDC and HVAC interconnections to a large offshore wind farm," pp. 1-8 Vol. 1,2005.
- [125] B. K. Johnson, R. H. Lasseter, F. L. Alvarado, and R. Adapa, "Superconducting current transfer devices for use with a superconducting LVdc mesh," *Applied Superconductivity, IEEE Transactions on*, vol. 4, pp. 216-222, 1994.
- [126] M. Hirose, T. MASUDA, K. E. N. I. SATO, and R. HATA, "High-temperature superconducting (HTS) dc cable," *SEI Tech. Review*, vol. 167, p. 42, 2005.
- [127] M. Elsherif, P. Taylor, and D. Hampshire, "Power Loss Evaluation of HVDC and DC HTS Transmission Solutions for Round 3 Offshore Wind Farms in the United Kingdom," in *International Conference on Energy Systems and Technologies (ICEST 2011)*, pp. 11-14,2011.
- [128] P. Chowdhuri and H. Laquer, "Some electrical characteristics of a dc superconducting cable," *Power Apparatus and Systems, IEEE Transactions on*, pp. 399-408, 1978.
- [129] P. Haugland, "It's time to connect: Technical description of HVDC Light® technology," *Ludvika, Sweden: ABB*, 2006.
- [130] R. Rudervall, J. Charpentier, and R. Sharma, "High voltage direct current (HVDC) transmission systems technology review paper," *Energy Week*, vol. 2, 2000.
- [131] M. Mahmud, M. Hossain, H. Pota, and A. Nasiruzzaman, "Voltage control of distribution networks with distributed generation using reactive power compensation," in *IECON 2011-37th Annual Conference on IEEE Industrial Electronics Society*, pp. 985-990,2011.
- [132] H. Hatta and H. Kobayashi, "A study of autonomous reactive power control method for distributed power generators to maintain power quality of the grid," *IEEJ Transactions on Electrical and Electronic Engineering*, vol. 1, pp. 233-239, 2006.
- [133] L. Ran, F. Spinato, P. Taylor, R. Wilson, and D. Jackman, "Coordinated AVR and tap changing control for an autonomous industrial power system," in *Generation, Transmission and Distribution, IEE Proceedings*, pp. 617-623. 2006.

- [134] M. Oshiro, K. Uchida, T. Senjyu, and A. Yona, "Voltage control in distribution systems considered reactive power output sharing in smart grid," in *Electrical Machines and Systems (ICEMS), 2010 International Conference on*, pp. 458-463, 2010.
- [135] R. Majumder, A. Ghosh, G. Ledwich, and F. Zare, "Load sharing and power quality enhanced operation of a distributed microgrid," *Renewable Power Generation, IET*, vol. 3, pp. 109-119, 2009.
- [136] S. Ingram, S. Probert, and K. Jackson, "The impact of small scale embedded generation on the operating parameters of distribution networks," *Department of Trade and Industry, Contractor: PB Power, Report No. K/EL/00303/04/01*, 2003.
- [137] 11kV Stranded Copper Conductor ,is available on : [http://www.prysmian.co.uk/export/sites/prysmianenGB/attach/pdf/Medium\\_Voltage\\_Cables/MV\\_Cables/bs7870\\_4\\_10\\_11kv\\_scc.pdf](http://www.prysmian.co.uk/export/sites/prysmianenGB/attach/pdf/Medium_Voltage_Cables/MV_Cables/bs7870_4_10_11kv_scc.pdf)
- [138] E. G. Set, "Computer Representation of Excitation Systems," *Power apparatus and systems, IEEE Transactions on* ,vol. 6, pp. 1460-1464, 1968
- [139] J. M. Saugrain, N. France, and P. Mirebeau, "Superconducting cables - status and applications ," *Tc (K)*, vol. 120, p. 140.
- [140] M. Stemmler, Medium voltage superconductor cable systems for inner city power supply." *Second seminar on Undergrounding of electric Distribution Networks, Brazil, 8-10 November 2011*.
- [141] G. Del-Rosario-Calaf, A. Sumper, X. Granados, and A. Sudria-Andreu, "Grid impact analysis of a HTSC cable by using an enhanced conventional simulator," in *Journal of Physics: Conference Series*, 2010, p. 03, 2007.
- [142] H. Noji, "AC loss of a high-superconducting power-cable conductor," *Superconductor Science and Technology*, vol. 10, p. 552, 1999.
- [143] M. Gelabert-Serra, A. Sumper, X. Granados, A. Sudria-Andreu, and J. Rull-Duran, "Dynamic Simulation of HTSC Cables With a Conventional Simulation Program," *Applied Superconductivity, IEEE Transactions on*, vol. 21, pp. 1025-1029, 2011.
- [144] H. Kimura, K. Honda, H. Hayashi, K. Tsutsumi, M. Iwakuma, K. Funaki, T. Bohno, A. Tomioka, Y. Yagi, and H. Maruyama, "Test results of a HTS power transformer connected to a power grid," *Physica C: Superconductivity*, vol. 372, pp. 1694-1697, 2002.

- [145] K. Funaki, M. Iwakuma, K. Kajikawa, M. Hara, J. Suchiro, T. Ito, Y. Takata, T. Bohno, S. I. Nose, and M. Konno, "Development of a 22 kV/6.9 kV single-phase model for a 3 MVA HTS power transformer," *Applied Superconductivity, IEEE Transactions on*, vol. 11, pp. 1578-1581, 2001.
- [146] M. A. A. Rahman, T. Lie, and K. Prasad, "Three-phase modeling of HTS transformer in distribution networks," in *IPEC, 2010 Conference Proceedings*, pp. 72-77, 2010.
- [147] R. Lee, A. Dada, E. Garcia, and S. Ringo, "Performance testing of a cryogenic refrigeration system for HTS cables," in *AIP Conference Proceedings*, p. 773, 2006.
- [148] M. Gouge, J. Demko, B. McConnell, and O. J. M. Pfothner, "Cryogenics Assessment Report," *Oak Ridge National Laboratory*, 2002.
- [149] M. Watanabe, T. Masuda, H. Yumura, H. Takigawa, Y. Ashibe, H. Ito, and etc., "Construction of 22.9-kV HTS Cable System for KEPCO Project in South Korea," *SEI Technical Review*, pp. p70-75, 2006.
- [150] Y. Xin, B. Hou, Y. Bi, K. Cao, Y. Zhang, S. Wu, H. Ding, G. Wang, Q. Liu, and Z. Han, "China's 30 m, 35 kV/2 kA ac HTS power cable project," *Superconductor Science and Technology*, vol. 17, p. S332, 2004.
- [151] Consultation on conflicts in the Distribution Losses Incentive Mechanism and data to be used in calculating its components by ofgem, p 2, 2012.
- [152] P. Richardson, D. Flynn, and A. Keane, "Impact assessment of varying penetrations of electric vehicles on low voltage distribution systems," in *Power and Energy Society General Meeting, 2010 IEEE*, pp. 1-6, 2010.
- [153] P. Papadopoulos, L. Cipcigan, N. Jenkins, and I. Grau, "Distribution networks with electric vehicles," in *Universities Power Engineering Conference (UPEC), 2009 Proceedings of the 44th International*, pp. 1-5, 2009.
- [154] L. Dale, D. Milborrow, R. Slark, and G. Strbac, "Total cost estimates for large-scale wind scenarios in UK," *Energy Policy*, vol. 32, pp. 1949-1956, 2004.
- [155] R. Webster, "Can the electricity distribution network cope with an influx of electric vehicles?," *Journal of power sources*, vol. 80, pp. 217-225, 1999.

- [156] S. Repo, H. Laaksonen, P. Jarventausta, O. Huhtala, and M. Mickelsson, "A case study of a voltage rise problem due to a large amount of distributed generation on a weak distribution network," in *Power Tech Conference Proceedings, 2003 IEEE Bologna*, 2003, p. 6 pp. Vol. 4.
- [157] M. Elsherif, P. Taylor, and D. Hampshire, "Investigating the Impact of High temperature Superconductor Cables on Electrical Distribution Networks," in *International Conference on Energy Systems and Technologies (ICEST 2011)*, pp. 11-14, 2011.
- [158] S. Karmacharya, G. Putrus, C. Underwood, and K. Mahkamov, "Evaluation of domestic electrical demand and its effect on low voltage network performance," in *47th Universities' Power Engineering Conference*, 4-7 September 2012, Brunel University, London, UK.
- [159] T. Nagasawa, M. Yamaguchi, S. Fukui, and M. Yamamoto, "Design requirements of a high temperature superconducting transformer," *Physica C: Superconductivity*, vol. 372, pp. 1715-1718, 2002.
- [160] T. Nagasawa, M. Yamaguchi, and S. Fukui, "Design study of a high-temperature superconducting transformer," *Electrical Engineering in Japan*, vol. 142, pp. 25-31, 2003.
- [161] T. Jiang, G. Putrus, Z. Gao, S. McDonald, and H. Wu, "Analysis of the combined impact of small-scale wind generators and electric vehicles on future power networks," in *Universities Power Engineering Conference (UPEC), 2012 47th International*, pp. 1-5, 2012.
- [162] A. Collinson, "Modelling the interaction between an in-line voltage regulator and doubly-fed induction generator," DTI New and Renewable Energy Programme 2003.
- [163] T. Hardono, C. Cook, and J. Jin, "Performance of High Temperature Superconducting Wires and Coils for Power Engineering Applications," in *Proceedings of Australasian Universities Power Engineering Conference, Hobart, Australia*, pp. 86-90, 1998.
- [164] Meeting the UK aviation target- options for reducing emissions to 2050, Committee on Climate Change December 2009 Naturally responsible.
- [165] H. Saadat, *Power system analysis*: WCB/McGraw-Hill Singapore, 1999.
- [166] S. Jupe, "Active management of distributed generation based on component thermal," PhD, School of Engineering and Computing Sciences, *Durham University*, 2009.

- [167] T. L. Baldwin, M. Steurer, and Y. Liu, "A novel method of controlling the effective impedance of a cold-dielectric, very low impedance, superconducting cable," *Applied Superconductivity, IEEE Transactions on*, vol. 15, pp. 1783-1786, 2005.
- [168] K. Funaki and M. Iwakuma, "Recent activities for applications to HTS transformers in Japan," *Superconductor Science and Technology*, vol. 13, p. 60, 2000.
- [169] T. Nagasawa, M. Yamaguchi, and S. Fukui, "Conceptual design of 100 MVA high temperature superconducting auto-transformers," *Applied Superconductivity, IEEE Transactions on*, vol. 13, pp. 2306-2309, 2003.
- [170] D.-Mei. Cao, D. Pudjianto, G. Strbac, R. Ferris, I. Foster, and M. Aten, "Examination of the impact of possible distribution network design on network losses," in *Electricity Distribution - Part 1, 2009. CIRED 2009. 20th International Conference and Exhibition on*, pp. 1-4, 2009.
- [171] S.Blake, "Methodologies for the evaluation and mitigation of distribution network risk," PhD, School of Engineering and Computing Sciences, *Durham University*, 2011.
- [172] Y.Zhang ; F.Li ; W.Yuan," Economic analysis of interconnected distribution substations vis superconductor cables," *Power and Energy Society General Meeting, 2012 IEEE*, p 1-5, 22-26 July, San Diego, CA, 2012.



## **Appendix1: Parameters for conventional and superconductor assets**

Conventional Transformer:  $Z=18\%$ ,  $15\text{MVA}$ ,  $YY0$  Windings,  $R_{\text{primary } 33\text{kV}} = 0.00016529 \text{ pu}$ ,  $R_{\text{secondary } 11\text{kV}} = 0.0014876 \text{ pu}$ , transformers in parallel,  $20/+20$  tap limits, AVC scheme with 1% bandwidth, voltage set point 11kV, tap step 0.167%, (pu values are based on machine rating 30MVA).

HTS Transformer  $Z=5\%$ ,  $R_{\text{primary } 33\text{kV}} = 0.00016529\text{pu}$ , 33/11kV, 30MVA,  $R_{\text{secondary } 11\text{kV}} = 0.0014876\text{pu}$ , (pu values are based on machine rating 30MVA).

Distributed generator: 9MVA, 11kV,  $X=2.22\text{pu}$ ,  $X'=0.338 \text{ pu}$ ,  $R_a=0.005 \text{ pu}$ . (pu values are based on machine rating 9MVA). Two generators with the same parameters.

Generator AVR:  $k_A=1266$ ,  $T_R=0.02$ ,  $k_E=1$ ,  $T_E=0.5$ ,  $k_f=0.03$ ,  $T_{F1}=0.6$ ,  $T_{F2}=1$ ,  $T_R=0.03$ .

$300 \text{ mm}^2$  copper cable parameters:  $Z=0.08+J0.0969 \text{ (m}\Omega/\text{km)}$ , 11kV, 11.43 MVA. Feeder cable comprises 5km and 7km of  $300 \text{ mm}^2$  copper cable. Totally length of cable is 12km.

$300 \text{ mm}^2$  copper cable parameters:  $Z=0.08+J0.0969 \text{ (m}\Omega/\text{km)}$ , 11kV, 11.43 MVA, Feeder cable comprises 1.5km and 1.5km of  $300 \text{ mm}^2$  copper cable. Totally length of cable is 3km.

Nexans HTS cable parameters'  $R=0.0001$  ( $\Omega/\text{km}$ )  $X =11.4$  ( $\text{m}\Omega/\text{km}$ ),  $C =2880.6$ ( $\text{nF}/\text{km}$ ), 40MVA, 11kV, It is for two feeders with length 12km and 3 km.

## **Appendix2: The energy losses a year and the cost of energy losses a year**

First step was to derive the demand for the case network study which is as shown below

$$\text{Demand} = \frac{\text{Maximum demand in my case study}}{\text{maximum demand of UK real data in distribution network}} \times \text{Varying}$$

demand for distribution network per a hour

Find the energy losses a year in the network by

$$= \left( \frac{\text{Demand for each frequency time a year}}{V} \right)^2 \times R$$

### **1. Conventional distribution network**

The energy losses a year= 1293.4 MW per half because the real UK demand data was given every half hour.

So, the energy losses a year = 1293.4×0.5= 646.7 MWh

The cost of energy losses = 646.7 (MWh) × 60£/(MWh)= £38.8 k per a year

### **2. Superconductor distribution network**

The energy losses a year = 2.78MW per half hour because the real UK demand data was given every half hour.

So, the energy losses a year = 2.78 ×0.5= 1.4 MWh

The energy losses a year for refrigeration systems in cables and transformers= 516.8 MWh

Therefore, the total energy losses a year for superconductor distribution network includes refrigeration systems = 518.2 MWh

The cost of energy losses = 518.2 (MWh) × 60£/(MWh)= £31.1 k per a year

### **Appendix3: The energy losses a year and the cost of energy losses a year**

#### **1. Conventional distribution network**

The energy losses a year= 8150 MW per half hour because the real UK demand data was given every half hour.

So, the energy losses a year =  $8150 \times 0.5 = 4075$  MWh

The cost of energy losses =  $4075 \text{ (MWh)} \times 60\text{£}/\text{(MWh)} = \text{£}244.5 \text{ k}$  per a year

#### **2. Superconductor distribution network**

The energy losses a year= 1630 MW per half hour because the real UK demand data was given every half hour.

So, the energy losses a year = 815 MWh

The energy losses a year for refrigeration systems in cables and transformers= 2312.2 MWh

Therefore, the total energy losses a year for superconductor distribution network includes refrigeration systems = 3127.2MWh

The cost of energy losses =  $3127.2 \text{ (MWh)} \times 60\text{£}/\text{(MWh)} = \text{£} 187.6\text{k}$  per a year