

# THE UNIVERSITY OF WARWICK

**Original citation:**

Dixon, S., Petcher, P. A., Fan, Y., Maisey, D. and Nickolds, P.. (2013) Ultrasonic metal sheet thickness measurement without prior wave speed calibration. Journal of Physics D: Applied Physics, Volume 46 (Number 44). Article number 445502.

**Permanent WRAP url:**

<http://wrap.warwick.ac.uk/58354>

**Copyright and reuse:**

The Warwick Research Archive Portal (WRAP) makes this work of researchers of the University of Warwick available open access under the following conditions.

This article is made available under the Creative Commons Attribution- 3.0 Unported (CC BY 3.0) license and may be reused according to the conditions of the license. For more details see <http://creativecommons.org/licenses/by/3.0/>

**A note on versions:**

The version presented in WRAP is the published version, or, version of record, and may be cited as it appears here.

For more information, please contact the WRAP Team at: [publications@warwick.ac.uk](mailto:publications@warwick.ac.uk)

warwick**publications**wrap  
  
highlight your research

<http://wrap.warwick.ac.uk/>

## Ultrasonic metal sheet thickness measurement without prior wave speed calibration

This content has been downloaded from IOPscience. Please scroll down to see the full text.

2013 J. Phys. D: Appl. Phys. 46 445502

(<http://iopscience.iop.org/0022-3727/46/44/445502>)

View [the table of contents for this issue](#), or go to the [journal homepage](#) for more

Download details:

IP Address: 137.205.202.79

This content was downloaded on 06/12/2013 at 11:54

Please note that [terms and conditions apply](#).

# Ultrasonic metal sheet thickness measurement without prior wave speed calibration

S Dixon, P A Petcher, Y Fan, D Maisey and P Nickolds

Department of Physics, University of Warwick, Coventry, CV4 7AL, UK

E-mail: [S.M.Dixon@warwick.ac.uk](mailto:S.M.Dixon@warwick.ac.uk)

Received 7 May 2013, in final form 7 August 2013

Published 17 October 2013

Online at [stacks.iop.org/JPhysD/46/445502](http://stacks.iop.org/JPhysD/46/445502)

## Abstract

Conventional ultrasonic mensuration of sample thickness from one side only requires the bulk wave reverberation time and a calibration speed. This speed changes with temperature, stress, and microstructure, limiting thickness measurement accuracy. Often, only one side of a sample is accessible, making *in situ* calibration impossible. Non-contact ultrasound can generate multiple shear horizontal guided wave modes on one side of a metal plate. Measuring propagation times of each mode at different transducer separations, allows sheet thickness to be calculated to better than 1% accuracy for sheets of at least 1.5 mm thickness, without any calibration.

(Some figures may appear in colour only in the online journal)

## 1. Introduction

In conventional ultrasonic thickness gauging of metals, a piezoelectric transducer is placed on a sample surface, and is used to generate and detect ultrasonic bulk waves within the sample [1]. The thickness is calculated from the transit time of a wave that reverberates through the thickness of the sample, using a calibration bulk wave speed. For ease of coupling the ultrasound from the transducer to the sample, a compression wave probe is usually used. The reasons to perform thickness gauging on a sample are multifarious, ranging from manufacturing quality control, through to in-service corrosion monitoring of key plant or structural components.

Instances arise where it is desirable to measure ultrasonically the thickness of a sample for which composition or alloy type may be uncertain, or the ultrasonic speed may vary with direction of propagation due to texture. Ultrasonic speed will also vary with temperature, stress and microstructure, so that even where the sample composition is known, it is not possible to guarantee the accuracy of the calibration speed that would be required for conventional ultrasonic thickness gauging.

This paper describes a method that uses ultrasonic shear horizontal (SH) guided wave modes [2] to measure thickness, with no a priori knowledge of the bulk wave ultrasonic speeds, and where it is only possible to obtain access to one side of the sample (a plate or sheet). This is achieved using the SH guided wave mode dispersion curves.

SH waves oscillate in the plane of the plate, perpendicular to the propagation direction (figure 1). When the wavelength of a particular wave mode is comparable to or longer than the sample thickness, the wave is coupled simultaneously to both sides of the sample and cannot be considered to be a bulk wave. Plates or sheets can support Lamb wave modes and SH guided wave modes. The SH guided wave modes are not as practical to generate in a controlled way, but their dispersion is far simpler than that of the Lamb wave modes, and this is one of the key attractions of the SH guided wave modes. The SH guided wave modes dispersion relation is [2]:

$$c_p = \frac{2c_T(fd)}{\sqrt{4(fd)^2 - n^2c_T^2}}. \quad (1)$$

The wave has a phase speed  $c_p$ , for a given mode of order  $n$ , which has a frequency of  $f$ , travelling in a plate of thickness  $d$ , with a bulk shear wave speed  $c_T$ . If  $n = 0$ ,  $c_p = c_T$ , and therefore the SH<sub>0</sub> speed experiences no dispersion and is

 Content from this work may be used under the terms of the [Creative Commons Attribution 3.0 licence](http://creativecommons.org/licenses/by/3.0/). Any further distribution of this work must maintain attribution to the author(s) and the title of the work, journal citation and DOI.

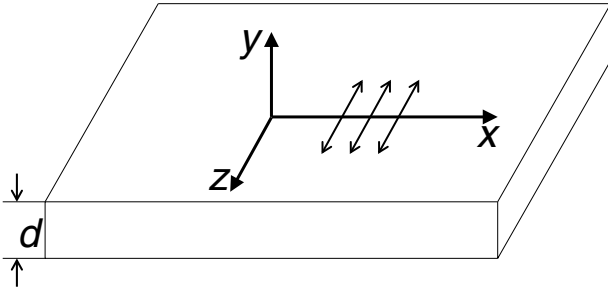

**Figure 1.** Guided SH wave modes propagate in the direction of the plane of the plate ( $x$ -axis) and oscillate in the plane of the plate orthogonal to the propagation direction ( $z$ -axis).

equal to the bulk shear wave speed. Rearranging equation (1) for sample thickness:

$$d = \frac{nc_Tc_p}{2f\sqrt{c_p^2 - c_T^2}}. \quad (2)$$

By generating an SH<sub>0</sub> wave and any other higher order SH mode at one transducer, and then translating the detecting transducer (remaining on the same side of the sample), to record the signal at another separation from the generator,  $c_T$ ,  $c_p$ , and  $f$  can be obtained. With  $n$  a known value, sample thickness can be measured without any a priori knowledge. Temperature, stress, microstructure, and texture (for a linear path traversed by the detecting transducer), do not alter the form of equations (1) and (2), only modifying the values of the terms. As the value of those terms are obtained again as part of each new thickness measurement, an accurate and reliable result can be achieved, despite the variation of sample properties due to conditions changing over time.

## 2. SH mode transduction using periodic permanent magnet electromagnetic acoustic transducers

Previously, researchers have reported single sided, metal plate thickness measurements, using electromagnetic acoustic transducers (EMATs) [3, 4] generating and detecting bulk waves [5] and other modes, including an alternative SH guided wave method [6].

The periodic permanent magnet (PPM) EMAT [7, 8], often used to generate SH guided wave modes, is characterized by alternating magnetic pole orientations (figure 2), the spacing determining the nominal acoustic wavelength.

The finite EMAT size gives it a spatial bandwidth analogous to a finite number of cycles giving a time domain signal a frequency bandwidth. A simple COMSOL model of the force generated by the alternating poles of the PPM EMAT yields the spatial force profile in figure 3. The fast Fourier transform (FFT) of the spatial force profile shown in figure 3, yields the spatial bandwidth profile of figure 4. The dominant wavelength is 6 mm in this case, corresponding to the PPM EMAT magnet periodicity, but smaller yet significant magnitude wavelength components are expected down to 5 mm and up to 7 mm. This considers the generator only; when using a detector with the same spatial profile, the total system response is the function squared, also shown in figure 4.

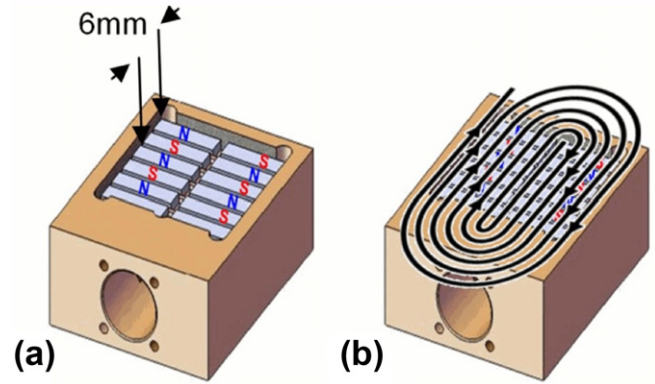

**Figure 2.** The SH wave or PPM EMAT consists of an array of alternating magnetic poles (a). Each magnet is 2.5 mm wide, and a 0.5 mm gap between magnets leads to a 6 mm periodicity. A coil placed above the magnets (b) will then generate and detect SH guided wave modes in metal sheets.

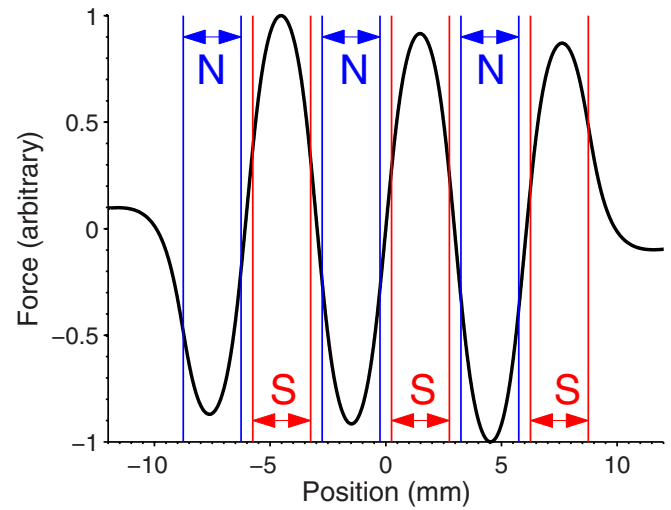

**Figure 3.** Approximation of the in-plane SH force generated by the PPM EMAT in figure 2.

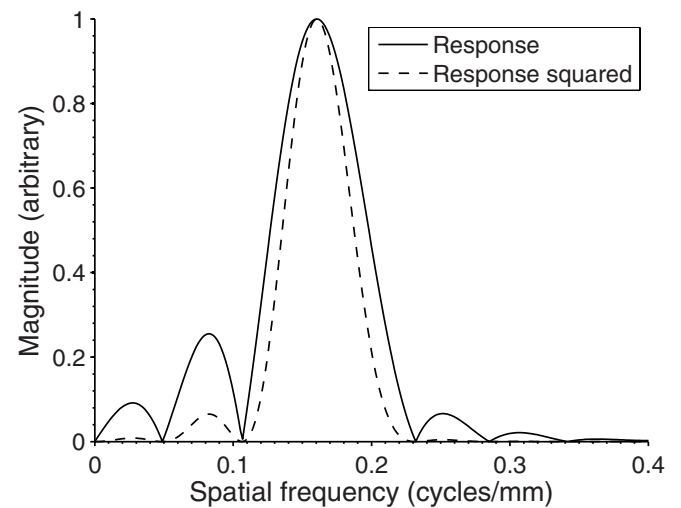

**Figure 4.** Approximation of the in-plane SH force spatial frequency generated by the PPM EMAT in figure 2. The bandwidth is narrower if more alternating magnets are used.

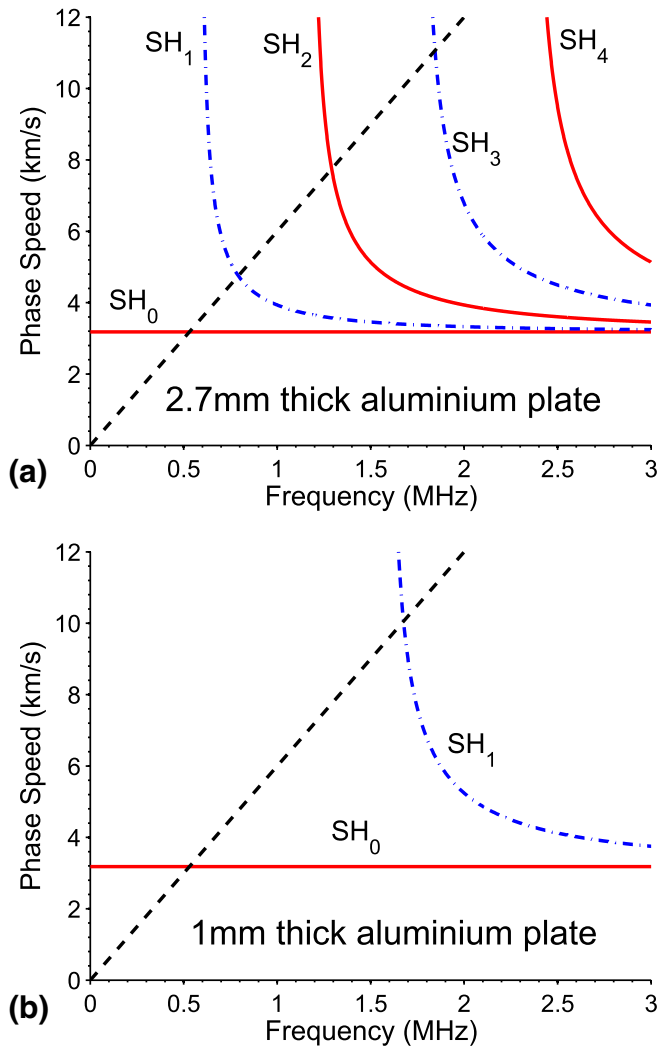

**Figure 5.** Dispersion curves for a 2.7 mm thick (a) and a 1 mm thick (b) aluminium plate, produced from equation (1). The dashed line on the plots represents a constant wavelength of 6 mm with nominal SH<sub>0</sub> phase speed of 3180 m s<sup>-1</sup>. Red solid lines are symmetric modes, blue dashed-dotted lines are anti-symmetric modes.

The existing literature generally neglects the transducer spatial bandwidth, and the sharp nature of figure 4 explains why in many cases it can be assumed, with reasonable results, that the only significant wavelength present corresponds to the periodicity of the magnets in the PPM EMAT. This dominant component corresponds to the (dashed) line of constant wavelength (6 mm in this case) plotted on the SH guided wave mode dispersion curves of figure 5. Where the dashed line intersects the dispersion curve should correspond to an optimum point for generating an SH wave and thus a large wave amplitude should be detected. A sufficiently wideband drive pulse sent to the transducer will generate SH modes at the specific points on the dispersion curve intersecting with the dashed line. A wider excitation bandwidth will generate more SH modes simultaneously.

The drive to an EMAT is often provided by a tone-burst of current, centred on a particular frequency, and typically 3 to 100 cycles. Reliably detecting the frequency at which SH waves for a constant wavelength are optimally excited

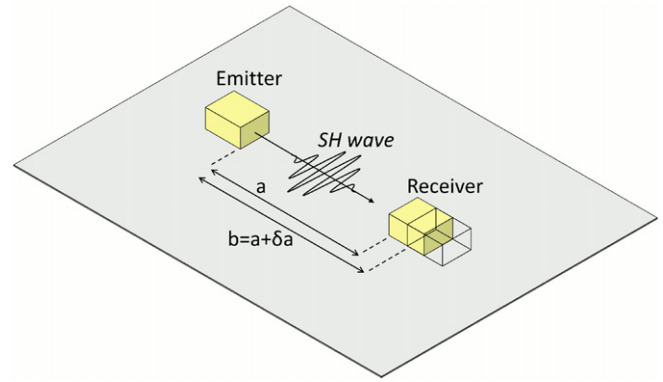

**Figure 6.** Thickness measurement experimental technique. The EMAT ultrasound generator is held static, and the detector starts at a distance  $a$  from it. SH<sub>0</sub> and SH<sub>1</sub> waves propagate between generator and detector. The detector is then moved to a distance  $b = a + \delta a$  from the generator, and again SH<sub>0</sub> and SH<sub>1</sub> waves propagate between them.

requires a well-defined amplifier and detection electronics response, and having a suitably slow frequency sweep with a narrow current pulse bandwidth. Luo and Rose [6] measured plate thickness in this way, by finding the maximum detected amplitude over a frequency sweep.

### 3. Experimental technique

The motivation for this work was to exploit the dispersion curves of the SH guided wave modes to measure thickness through a time rather than amplitude measurement. Time measurements generally provide superior accuracy and reliability compared to using the amplitude value. Measuring a time can also be quicker, as it does not rely on slowly sweeping a frequency, and thus is more suitable for automated and online measurements.

Initially, one EMAT is driven with a wideband tone-burst pulse of sufficient bandwidth to generate both the SH<sub>0</sub> mode and the SH<sub>1</sub> or a higher order mode, which is detected at the second EMAT; the EMAT configuration is shown in figure 6.

The combined response of the generator and detector is such that the centre frequency of the generated SH<sub>0</sub> and SH<sub>1</sub> (or higher mode) can be measured using an FFT of the windowed modes, and the signal recorded. The system is immediately driven again with a narrowband  $N$  cycle tone-burst, at a centre frequency corresponding to that of the SH<sub>1</sub> or higher order mode (this centre frequency is used as the required  $f$  in equation (2)). For EMATs of wavelength  $\lambda$ , and a structure consisting of  $E$  wavelengths ( $E = 3$  in figures 2 and 3),  $N$  is given by:

$$N = f\lambda(2E + 1)/c_g. \quad (3)$$

The group speed,  $c_g$ , is not known, but can be approximated based upon the wavelength, frequency, and approximate shear wave speed ( $c_T$ ).

A typical narrowband SH<sub>1</sub> wave pulse is shown in figure 7. One EMAT is then moved a small fixed distance,  $\delta a$ , parallel to the line between the two EMATs (to the position of the wireframe depicted in figure 6), with the same SH<sub>1</sub> frequency

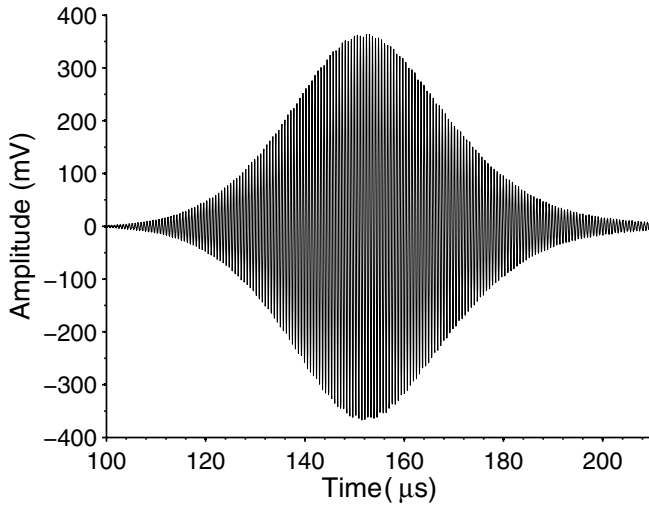

**Figure 7.** SH<sub>1</sub> wave; generated and detected by PPM EMATs with 6 mm periodicity. A large number of cycles (equation (3)) are required for reliable phase speed measurement. In this case, 50 cycles were input into the generation EMAT, but far more cycles are detected due to the nature of generating and detecting dispersive waves.

being generated, and the signal recorded as the transducer is moved. Once the second position is reached, the wideband tone-burst pulse is used again, and the SH<sub>0</sub> signal recorded. For a faster implementation, two separate EMAT detectors a fixed distance apart could be used; in the case of figure 6, both detector coils would be incorporated into a single monolithic EMAT for convenience and repeatability. However, in this single EMAT case, the separation between them must be very small, or the phase wrapping will introduce ambiguity to the measurement.

The shift in time as the transducer separation changes is measured by tracking a single peak as the transducer is moved (a simple task manually or automatically with a basic algorithm), which typically provides the shift to within two sampling points, and avoids any ambiguity due to phase wrapping regardless of the distance moved. However, the distance moved is kept small as the SH<sub>1</sub> wave packet has slight changes in frequency as you move away from its centre point. Further accuracy is obtained by windowing a small section of both signals (5 cycles of the SH<sub>1</sub> wave either side of the tracked point is sufficient), performing an FFT on both, and comparing the phase of the peak frequency. The temporal shift is given by the difference in phase shift divided by the frequency, with care taken regarding phase wrapping (if the peak has been tracked correctly, the phase difference magnitude will always be less than  $2\pi$ ).

$$\delta t = (\phi_2 - \phi_1)/2\pi f. \quad (4)$$

This shift must be added to the shift measured during tracking of the peak, to get the total change in time,  $\delta T$ . The phase speed is then:

$$c_p = \delta T/\delta a. \quad (5)$$

The SH<sub>0</sub> mode is non-dispersive, and hence there is no ambiguity from phase wrapping. A cross-correlation operating on the entire SH<sub>0</sub> wave packet measures the time shift, providing  $c_T$ .

**Table 1.** Thickness measurements on aluminum, using the EMATs with nominal wavelengths of 6 mm and 10 mm, are shown in bold and regular text respectively.

Micrometer (mm)	EMAT (mm)±1%	Difference (%)
1.00 ± 0.25%	0.99	1.7
<b>1.00 ± 0.25%</b>	<b>1.02</b>	<b>2.0</b>
1.50 ± 0.25%	1.51	0.7
<b>2.10 ± 0.25%</b>	<b>2.10</b>	<b>0.2</b>
<b>2.10 ± 0.25%</b>	<b>2.08</b>	<b>1.0</b>
2.48 ± 0.25%	2.47	0.5
2.48 ± 0.25%	2.48	0.2
2.97 ± 0.25%	2.93	1.3
5.61 ± 0.50%	5.60	0.1

**Table 2.** Thickness measurements on 316 stainless steel, using the EMATs with nominal wavelengths of 6 mm and 10 mm, are shown in bold and regular text respectively.

Micrometer (mm)	EMAT (mm)±1%	Difference (%)
1.02 ± 2.0%	1.04	1.4
<b>1.02 ± 2.0%</b>	<b>1.04</b>	<b>1.9</b>
<b>1.98 ± 0.2%</b>	<b>2.00</b>	<b>1.1</b>
<b>2.52 ± 0.2%</b>	<b>2.50</b>	<b>0.4</b>
<b>3.23 ± 1.5%</b>	<b>3.20</b>	<b>0.5</b>
3.26 ± 1.5%	3.28	0.5
<b>3.26 ± 1.5%</b>	<b>3.29</b>	<b>0.9</b>

The initial separation between the EMATs is generally kept as small as possible. The limiting factor is the dead time caused by the pulse that generates the ultrasound. The initial inspection distance,  $a$ , must then be at least the dead time multiplied by the shear wave speed,  $c_T$ . The maximum dead time observed is the number of cycles in the generation pulse,  $N$ , divided by the frequency of the generation pulse,  $f$ . A factor dependent on the pulse generator,  $g$ , is also present:

$$a_{\min} = (g + N/f)c_T. \quad (6)$$

Above this minimum requirement, the inspection distance is arbitrary as long as the waves of interest are received without interference from other waves. The distance moved,  $\delta a$ , must be kept small when measuring the SH<sub>1</sub> phase speed, as the frequency can change sufficiently to cause large errors if a very different section of the wave packet envelope is sampled. Typically,  $\delta a$  was restricted to a single wavelength, but the same restriction is not required for the SH<sub>0</sub> speed,  $c_T$ , and if desired, a third position at a much greater  $\delta a$  can be used. For these measurements, it was generally sufficient to measure the SH<sub>0</sub> speed at the same position used to measure the SH<sub>1</sub> speed.

## 4. Results

Regardless of temperature, stress, and microstructure, as long as the sample is homogeneous and hence the speeds constant over the linear path along which the transducer moves, then equation (2) applies and the technique will provide an accurate thickness. This would not be the case for methods that measured speeds a priori, as conditions could have changed.

Results for a range of aluminum and stainless steel plates are shown in tables 1 and 2 respectively. The micrometer

value is an average of 10 measurements of thickness taken at various points along the edge of the plate, with a variable standard deviation between plates. The EMAT value is the thickness measurements calculated from the EMAT data, with an error dominated by the EMAT separation measurement error of approximately 1% in 10 mm. The difference percentage is given by:

$$\text{Difference} = 100 \times (\text{EMAT/Micrometer} - 1). \quad (7)$$

The difference calculated uses the unrounded micrometer and EMAT values, whereas only the values rounded to two decimal places are shown in the tables. This is the reason for what may appear to be discrepancies between the measurement values and the final difference calculated.

Over the range of samples investigated so far, accuracy tends to decrease as plate thickness decreases for a given periodicity of EMAT magnets. This is because as plate thickness decreases, the intersection of the line of constant wavelength with the SH<sub>1</sub> or higher order modes shifts to steeper points of the curve (as seen in figure 5). At such points, the wave is more dispersive, and it is necessary to use a larger number of cycles to ensure accurate measurement of the phase speed of the wave packet centre frequency.

## 5. Conclusions

Plate thickness can be measured relatively quickly and using simple signal processing methods, to a typical accuracy of 1% (when accounting for variations in micrometer measured thickness), without any a priori knowledge of the elastic

constants of the sheet, and with access to only one side of the sheet. Errors can be worse for thinner plates or 'longer wavelength' EMATs; the general effect is that accuracy decreases (errors up to 2% have been seen in testing) where the nominal EMAT wavelength line intersects the steeper section of the guided SH wave dispersion curve. This is an example of a metrological use for guided wave dispersion relations.

## Acknowledgment

This work was supported by the Engineering and Physical Sciences Research Council (EPSRC), grant EP/I03160X/1.

## References

- [1] Krautkramer J and Krautkramer H 1990 *Ultrasonic Testing of Materials* (New York: Springer)
- [2] Rose J L 1999 *Ultrasonic Waves in Solid Media* (Cambridge: Cambridge University Press)
- [3] Dobbs E R 1973 Electromagnetic generation of ultrasonic waves *Physical Acoustics: Principles and Methods* vol 10 (New York: Academic) pp 127–89
- [4] Hirao M and Ogi H 2003 *EMATS for Science and Industry: Noncontacting Ultrasonic Measurements* (Boston, MA: Kluwer Academic Publishers)
- [5] Dixon S, Edwards C and Palmer S B 2001 *Ultrasonics* **39** 445
- [6] Luo W and Rose J L 2003 *Insight* **45** 735
- [7] Thompson R B 1990 Physical principles of measurements with EMAT transducers *Physical Acoustics: Principles and Methods* vol 19 (New York: Academic) pp 157–200
- [8] Nurmalia, Nakamura N, Ogi H, Hirao M and Nakahata K 2012 *NDT & E Int.* **45** 156