

CASE STUDY 95-04

Operator Certification: A Case Study in Operator Self-Inspection

Prepared by: Stacey Cowap
 James Schoonmaker
 Lean Aircraft Initiative
 Massachusetts Institute of Technology
 77 Massachusetts Avenue, 33-407
 Cambridge, MA 02139

February 22, 1996

The authors acknowledge the financial support for this research made available by the Lean Aircraft Initiative at MIT sponsored jointly by the US Air Force and a group of aerospace companies. All facts, statements, opinions, and conclusions expressed herein are solely those of the authors and do not in any way reflect those of the Lean Aircraft Initiative, the US Air Force, the sponsoring companies (individually or as a group), or MIT. The latter are absolved from any remaining errors or shortcomings for which the authors take full responsibility.

Executive Summary for Operator Certification: A Case Study in Operator Self-Inspection

Operator certification is the process where production workers are trained, authorized, and given the necessary resources to inspect their own work. This case study evaluated operator certification systems in the manufacturing process at three major aerospace companies during the Spring of 1995. Within the manufacturing area, operator certification was observed in such operations as high volume machining operations, certain processing operations-such as leak testing, balancing, and painting-and production of high volume detail parts.

This case study was initiated as a result of the data from the human resources focus group's survey in 1994. Prof. Jan Klein found that the airframe sector had a significantly lower percentage of plants where production workers perform inspection tasks as compared to the engine and electronics sectors. While operator certification is not a new concept, it appeared to be a best practice within two of the three sectors of the aerospace industry. This case study was performed to investigate these high potential payoffs.

The objectives of the certification programs which were common across the companies evaluated were:

- To provide immediate detection of operator, machine, and process errors.
- To provide an alternative to 100% inline inspection by quality personnel.
- To provide greater incentive to manufacturing personnel to identify part status accurately.
- To provide positive feedback to operators to prevent re-occurring errors.

It is important to note that all of the common objectives revolve around a quality control or worker empowerment theme.

The case study indicates that those companies with successful operator certification programs invested time in identifying all of the stakeholders and addressing their needs and concerns in the operator certification system. The groups of stakeholders common across the companies were operators, manufacturing engineers, the quality assurance organization, floor supervisors, management, customers, and labor representatives.

Some examples of the benefits realized due to implementation of the operator certification system include, at one company, a 66% decrease of manufacturing induced Material Review Board (MRB) actions for all products, with a 90% MRB action decrease for military products. One company attributes the decrease in their manufacturing division shop lead times, from 12.1 to 7.3 weeks, solely to the implementation of operator certification. At another company, where several improvements were implemented simultaneously, an average part was chosen and the benefits due to operator certification were reviewed. On this one part, Industrial Engineering/Standard hours had decreased from 110 to 81 minutes, approximately 26%.

When reviewing the key elements for implementation of operator certification, four aspects of the process were emphasized by each of the companies as necessary for success. These were corporate commitment, data management, Labor/DPRO buy-in, and managing the human interface.

Within the area of corporate commitment, the companies defined five components which proved crucial to success. These were a dedicated project coordinator, the allocation of necessary funds (including salaries of dedicated personnel, training costs, and computer requirements), a

feasibility study, a pilot program to demonstrate program effectiveness and identify problems on a small scale, and a sustained operator certification program over many years. The allocation of funds is hard to generalize and depends upon the specific type of system a company implements. A company could start with a very inexpensive system, tracked manually, or implement a very sophisticated computer system to track all data across multiple computer systems. Each of the companies discussed performing feasibility studies and pilot programs. The purpose of the feasibility study is to determine what aspects of the operator certification system will or will not work within a company's specific environment. This changes not only between companies, but between plants within a company. The companies also emphasized the importance of pilot programs started on a small localized basis. These allow findings to correlate success before tailgate inspections are canceled. At each of these companies, though, there was an emphasis on operator certification being a culture change, not a short term cost savings program.

When discussing the area of data management, each company emphasized the need to minimize the impact on the operator. One company integrated several existing databases to maximize the operators' effectiveness. This resulted in a single computer entry screen for the operators, which was viewed as an improvement to their job functions and eventually a welcomed change. This study found that the computerized systems saw the greatest returns from the operator certification system. The companies which had linked their operator certification database to other databases within the company were able to provide documentation for savings and thus able to identify the greatest savings.

Operator certification, by its name and nature, is a human-based change. This program changes the way people accomplish their work. As such, managing the human interaction with the certification system was important to success at each of the companies. This was very company and plant specific due to different group relationships. One of the most important aspects to achieving success when implementing operator certification was to provide training for all the stakeholders. One company stressed that in addition to classroom training, they emphasized on-the-job training to allow use of the new skills. It is important to note that this company did not put any limit on the training needed by operators to become competent. They received on-the-job training until they were able to be certified. The training progressed at individual rates, and allowed everyone to become certified. The study found that peer recognition was an important source of pride to each operator.

In summary, this case study evaluated several operator certification systems, some which had been in operation for over fifteen years. It was discovered that successful implementation is not founded on a short term cost savings program. Instead, it is a cultural change which takes significant amounts of time and money to implement. This requires the company to be fully committed to the operator certification program.

Operator Certification: A Case Study in Operator Self-Inspection

Abstract

Operator certification is the process where production workers are taught, authorized, and given the resources necessary to inspect their own work. This case study analyzed the process of implementing an operator certification program at three aerospace firms in order to identify factors which lead to a successful implementation. The case study used data gathered through personal interviews and procedure reviews at each of the companies to determine that there were several common characteristics in each of the programs studied. These characteristics were:

- The system was tailored to fit the specific needs of each company.
- Corporate commitment to successful implementation of a self-inspection system to improve product quality, especially when cultural changes are involved.
- The use of pilot programs during the implementation process.

Operator Certification: A Case Study in Operator Self-Inspection

This case study examines the hypothesis that a flexible workforce can reduce costs and cycle time while maintaining, or improving, existing quality levels. The specific example of worker flexibility analyzed in this study is an operator's ability to inspect their own work. The development of this type of inspection system is reviewed at three unionized aerospace manufacturing plants. The history, objectives, and implementation of each company's system were studied. This case study documents successful aspects of these systems which could aid other aerospace firms in implementing an operator certification program.

Definition

Operator certification is the process where production workers are taught, authorized, and given the resources necessary to inspect their own work. Figure 1 shows the flow of work through an operator's station with operator self-inspection certification, while Figure 2 shows the workflow without operator certification. Figure 2 identifies a

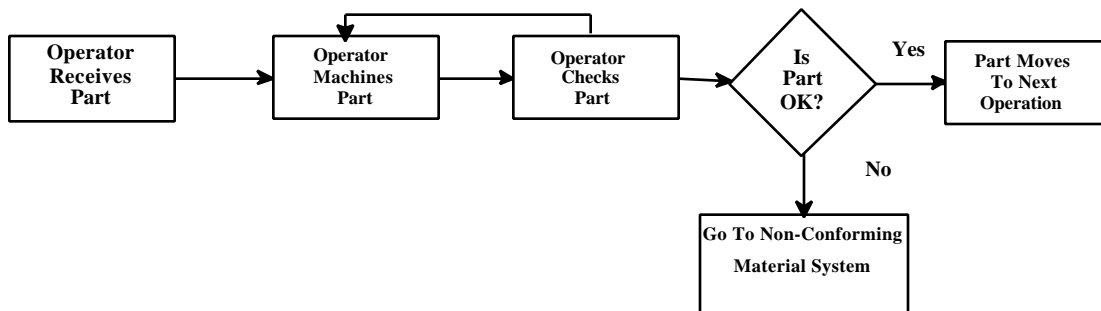

Figure 1. Workflow with operator certification.

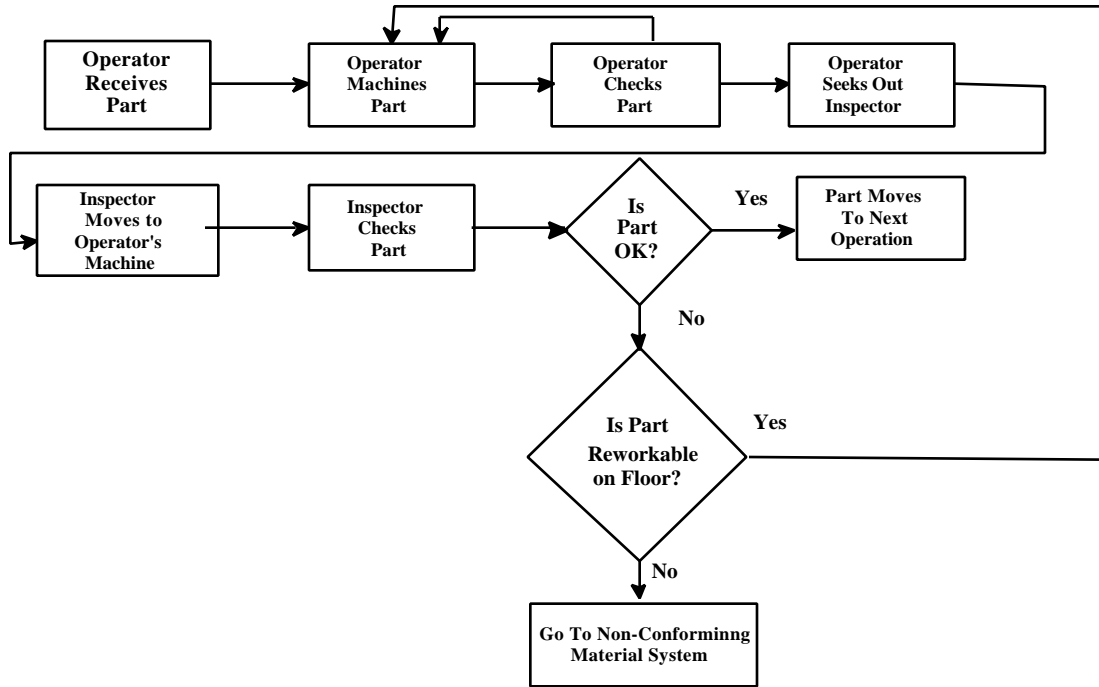

Figure 2. Workflow without operator certification.

workflow example where the inspector moves to the operator's station to inspect a part. Some companies make use of a workflow where the part is taken to an inspector's station.

While companies implement operator certification programs for numerous reasons, this study found a common objective of increased product quality at each company studied. The companies recognized that, while the operators are capable of checking their work, they were never trained, provided with the tools, or authorized to do so. With proper training and other necessary adjustments to their manufacturing processes, these companies believed that an operator could be trusted to measure the required manufacturing characteristics properly and consistently every time. This belief is consistent with the objective of operator ownership of their products and processes.

The Lean Aircraft Initiative, at the Massachusetts Institute of Technology, decided to study operator self-inspection programs as a result of a Human Resources Focus Group survey

which was conducted in 1994. The percentage of plants where production workers perform inspection tasks (within the aerospace industry) was reported to the Advisory Board in September, 1994, and is shown in Table 1.

Table 1. Inspection tasks.¹

	Incoming Material	Work In-Progress	Finished Goods
Airframe (12 plants)	8%	17%	8%
Avionics (12 plants)	42%	67%	50%
Engines (10 plants)	30%	80%	60%
Industry (34 plants)	26%	53%	38%

As a result of this information, the Lean Aircraft Initiative began investigating the factors which lead to a successful implementation of certifying operators to perform self-inspection tasks. Although the concept is not new to many aerospace manufacturers, operator certification appears to be a best practice for lean manufacturing processes and has high potential payoffs. Consequently, it was determined that an understanding of the mechanics of an operator certification program and how it can be effectively implemented would be of benefit to the Lean Aircraft Initiative.

Objectives

When implementing operator self-inspection programs, companies adopt different practices and implementation plans. However, the one common theme was the desire to improve product quality in manufacturing processes. In the aerospace industry, quality is always of primary importance. This study found that operator inspection programs result in quality improvements when implemented properly.

The common company objectives were:

- Provide immediate detection of operator, machine, and process errors,

¹ Klein, J. Lean Aircraft Initiative, Advisory Board Meeting. September 1994.

- Provide an alternative to 100% in-line inspection by quality control personnel,
- Provide greater incentive to manufacturing personnel to identify part status accurately, and
- Provide positive feedback to operators to prevent errors from re-occurring.

History/Background

Company A

Company A believes that the purpose of having certified operators is to place the responsibility for product quality in the hands of the employees who perform the work.² In 1994, as part of a larger program to implement self-directed work teams, this company began implementing operator inspection in their plant. At the time of this case study, there were no results which can be attributed directly to this program. Company A was included in this study in order to highlight a recent implementation approach.

Company B

Company B, after an initially unsuccessful attempt in 1976, assigned an experienced employee the task of implementing an operator certification program in 1983. In 1984, a pilot program was established and implemented. The primary goal of this program was to provide a method of prevention, instead of one of detection. With tailgate (end-of-line) inspections, the company was locked into a culture where production personnel “make” the product, and quality control personnel “inspect” the work. Unfortunately, this did not allow for positive feedback to the operators nor did it allow them to learn from their errors. Large quality control organizations were required in order to support inspections for all required manufacturing characteristics. This induced a delay in the operator’s productivity, since they needed to find an inspector after completing their activities.

² Sorenson, E. *Self-Directed Work Teams at an Aerospace Company*, MIT Sloan School of Management Master’s Thesis, 1995.

At the heart of the issue, though, was a desire to increase product quality and decrease risks to the company due to product defects. Knowing that product quality and integrity was critical to their continued success as an aerospace firm, they recognized that, while operators are capable of checking their work, they were never trained, provided with all the necessary tools, nor trusted to do so. With proper training and other necessary adjustments to their manufacturing support systems, Company B believed that an operator could be relied upon to measure the required manufacturing characteristic properly and consistently every time.

Company C

At Company C, the operator inspection philosophy was adopted in the late 1960's as one of several improvements to their manufacturing line. When trying to determine why they were encountering so many discrepancies in one area, one of the primary conclusions was that the engineering critical characteristics did not represent the manufacturing process critical characteristics. Operator certification evolved from a desire for the operator to "own the part." Ensuring the operator had the right tools and the knowledge to use them enabled the operator to become responsible for the quality of the part.

Once the problems in the one area were resolved, and the positive results of operator certification were identified, Company C started to implement operator certification in the rest of their manufacturing areas in the early to mid 1970's. It must be noted that, at Company C, operators had always been responsible to "check" certain critical characteristics. The implementation of an operator certification program formalized the corporate belief that product quality is most important, and it is more beneficial to inspect a part early in the process before adding value to a defective product.

When reviewing the reasons Company C felt motivated to implement operator certification, it is important to note that the main reason was product quality. All of the employees interviewed talked about two common themes of the program: (1) people's lives (i.e. airplane pilots and passengers) depend on the quality of the parts made at Company C, and (2) this program provides the operators with a sense of pride in their work.

Before describing the implementation process which leads to an effective operator self-inspection program, it is important to understand who the stakeholders are in the process. In order to be successful, the program must address the concerns of each of these groups. In addition to the five key roles of the people actively involved in manufacturing and inspection (described in the section entitled Roles), the concerns of management, customers, and labor must also be addressed (discussed in the section entitled Implementation).

Roles

Operators are not the only individuals involved in this process. Several functional organizations have a direct impact on the success of an operator certification program. Company B recognized that their roles were crucial to its success and included their responsibilities as part of their operator certification program. The five key job classifications are: the manufacturing engineer, the shop (or manufacturing) supervisor, the operator, the inspector, and the quality assurance supervisor/engineer. The following role definitions describe the key functions of each stakeholder. Functions may be performed by different stakeholders or combined within the responsibility of one person based upon a company's structure or philosophy, but the results of this study show that stakeholders need to assume responsibility for these key roles to ensure successful implementation.

Manufacturing Engineer

Company B defined one of the most important adjustments to the manufacturing support system to be revising procedures and work instructions. They felt it was critically important that the operator understand exactly what the characteristics are that must be measured and how to measure them. The manufacturing engineer (or process planner) provided this information in the form of work instructions to the operators. The engineers completely reviewed all processes, sequence by sequence, and ensured that the part characteristics were clear and inspectable by the operator.

As a method for ensuring the work instructions were coordinated among the stakeholders they affected, Company B created a three-tiered implementation process for work instructions: conditional, tryout, and approved for production. This encouraged the manufacturing engineers to work with the operators during a process trial in order to ensure that the instructions were clear and executable. Prior to the implementation of this process change, revisions to work instructions could take six months to implement. After improving the procedures for work instruction feedback, the manufacturing engineer reacted to and made changes in the work instructions whenever needed, and as soon as possible. The average time to make changes became days rather than months. If one manufacturing engineer was continually having trouble writing work instructions that could be understood by the operators, that person could be “decommissioned” by management. A decommissioned manufacturing engineer could not produce any work instructions approved for production. All their work instructions required management review. This appeared to ensure that manufacturing engineers understood and reacted to legitimate operator concerns.

Once Company C discovered that they had a mismatch between engineering and manufacturing characteristics, the manufacturing engineers redefined all characteristics on the original engineering drawings for one of the company’s manufacturing lines. The goal was to standardize the characteristics and inspection gages that were called out on the drawings. The measurement tools were redesigned to make them easy to read and as accurate as possible. Then the tooling and manufacturing system were analyzed in order to ensure that they supported the goals of the operator acceptance plan.

In a continuous effort to improve tooling and other aspects of the manufacturing process, Company C continued this effort into the 1990’s and assembled a development cycle guide. This document spells out how to perform “design” work in order to incorporate the appropriate aspects (such as gaging methods) for the manufacturing process. They also reorganized their design engineering organization to make sure that the engineers are familiar with, and participate in the teams on the manufacturing floor.

Shop Supervisor

The shop (or manufacturing) supervisors were responsible for ensuring that operators received the training they needed and could determine part acceptability. Supervisors also assisted in investigations when required. An investigation by a manufacturing (shop) supervisor and a quality supervisor was required if an inspector and operator disagreed on the acceptability of part characteristics. After receiving input from the operator and the inspector, this investigation removed the two people with the most interest from the disagreement and allowed for a more objective review. There were no automatic actions which resulted from an investigation. Each was handled on a case-by-case basis.

Operator

The operator was responsible for inspecting part characteristics or processes when called out in a work instruction. The operators notified their supervision of any nonconformances, and generated the appropriate non-conformance documentation for the situation. This allowed the company to work towards the root cause of problems and attempt to eliminate repetitive nonconformances. The operators also were trained to not deviate from the work instructions, or it could affect their certification. If the inspection could not be performed as called out in the work instruction, the operator was obliged (and this aspect was reinforced during the training program) to make this known to the manufacturing engineer. Having the “freedom to make the call” was critical to the success of the operator inspection process. At Company B, multiple sources (at different positions within the operator certification system) stressed the company’s commitment to product integrity and the need for the operators to feel committed to the ethics of the program.

Inspector

The inspector audited parts under the operator inspection system at established inspection frequencies. They were required to inspect all of the work of operators who were uncertified, decertified, or under review. They also notified the manufacturing and quality

supervisors when there was an inspection required due to discrepancies found during audits. The inspectors were also encouraged to be present during all process try outs and to take responsibility to help train all operators.

This study observed inspectors as part of the manufacturing cell, reporting to the shop supervisor (Company B), and as resident on the manufacturing floor, but reporting to a quality supervisor (Company C). It appears that either organizational strategy can work with operator certification programs. At Company B, though, the management was in the process of reorganizing the inspectors from reporting to the shop supervisor to reporting to a quality supervisor. These inspectors felt that they were more effective working as part of the manufacturing cell, and had more control over training and inspection issues. The inspectors believed that by reporting to the shop (or cell) supervisor, they could be more proactive and solve issues immediately at the level at which they occurred.

Quality Assurance Supervisor

The quality assurance supervisors were the administrators of the operator certification program in their areas. They ensured that the operators' work instructions were clear and could be accomplished. The quality supervisors controlled the certification status of the operators in their areas and were the only people who could decertify operators. The quality supervisors assisted in investigations when discrepancies arose and they determined what follow-up activities were necessary.

In addition to clearly defining the responsibilities of the stakeholders, each of the companies spent significant amounts of time evaluating the best way for them to administer an operator self-inspection program. Prior to the implementation of any system, each company performed an evaluation of their plants in order to determine how to effectively implement an operator certification system. One of the key decisions made by each company was the degree of computerization they needed to maintain the data for the certification system.

Mechanics - Fully Computerized

The operator certification program at Company B was a fully computerized one. It was a separate database, but was integrated with the data from other systems, such as parts control and financial information. The system had several unique features which added to its success. Since the system was computerized and interacted with the other databases at Company B, quality assurance statistics and metrics were easily accessed. An on-line computer program determined the random audit selections of operators. This system maintained a history file of part, operator, and inspector activity in order to comply with government requirements for quality inspection documentation. There were terminals available at each work station for the operators, and since the work instructions were also computerized, there were no additional, cumbersome notations required by the operator.

One of the unique features of this system was what is referred to as the “escape” code. Each operator had a specific code which was his/hers alone that must be entered to certify an inspected part. This was not their employee number or any other employee information number. Company B wanted this unique quality symbol to stand only for quality. The manufacturing supervisor did not have access to this code, and could not enter an inspection as passed. Company B also addressed the issue of operators who were concerned about receiving pressure (real or perceived) from their supervisors to pass on an item or to hurry through an operation. They have the option to enter a specific “escape” code. This tells the system that the operator does not certify it, but the screen appears the same as if the operator had passed the part as normal. Within the computer system, this will generate an immediate inspection in this operator’s area.

Operators were certified after they received the proper level of training in the use of the necessary tools, or, in the case of a transfer, based upon their quality records of prior performance and approval of the manufacturing and quality managers. There are 10 levels of certification in the Company B operator certification system, and each level indicates a different level of inspector audit.

A new operator, after receiving all the necessary training, will have a required 100% audit by an inspector for a given number (which is determined statistically on the average number accomplished per day) of parts or inspectable characteristics. Once they have passed this, they will be considered “certified,” at level 1. The number of parts or characteristics are reviewed in order to allow an average person to be certified within five working days. As a level 1 certified operator, the audit rate is 20%. The operator moves to each successive certification level after seven successful audits. The audit rates for each of the levels are in Table 2.

Table 2. Inspection audit rates by certification level.

1	2	3	4	5	6	7	8	9	10
20%	10%	6.7%	5%	4%	2%	1.3%	1%	0.7%	0.5%

The audit rates beyond level 6 do not contribute statistically to reducing company B’s risk or staffing because of the high volume of part produced; they are used only as a measure of personal advancement and pride for the operators. It takes, on average, thirteen months to go from level 1 to level 6. It takes about four and one-third years to make it to level 10.

Mechanics - Manual to Computerized

In the 1970’s, the operator certification at Company C was a manual paper system. An operator would be certified to perform his/her job for a certain number of months before the next audit inspection was required. The length of time between inspections was determined by the level of certification which varied from one to nine months. Each operator was given a certain color card which designated their level of certification. The inspector would consult a random number list in order to determine who was audited at the appropriate time. This random audit verified the capability of the operator to perform inspections. Since the Department of Defense focuses their attention on verifying the quality of completed products, product audits were also incorporated to verify that the process is producing quality products, and were considered the redundant portion of the audit system.

In the early 1990's, Company C decided to standardize their operator certification program among their different manufacturing areas, and started to computerize it. Their system resided on a stand-alone computer system, and did not interface with nor provide data to any of the other Company C databases. There was no distinction between military or commercial work, and the system applied to all workers across the plant. The program was described in a quality control work instruction and maintained by quality control administrators. There are several levels of operator access and data protection. For the operator, the work associated with this system is minimized by only recording information on a characteristic if it does not pass inspection. The final inspection operation (performed by inspectors who work for the manufacturing organization) performed a check to ensure that all paperwork and operator inspection notations were present, checked for any obvious physical damage to the finished product, and stamped the move tag to signify the part was ready for the next process.

Benefits

At Company A, the operator inspection system was only initiated in 1994, so the benefits of the program have not been fully realized. Also, since operator inspection was instituted as part of several other changes in trying to implement self-directed work teams, it will be difficult to attribute benefits directly to this part of the process.

At Company B, the operator certification program was implemented in pilot programs from 1984 through 1986. Company B recognizes 1987 as the year the program was implemented on a company-wide basis. From 1986 to 1992, they increased the number of manufacturing sequences available for operator certification from 75,700 to 319,000. Their mechanical inspection manpower decreased 44%. During the same time, manufacturing induced Material Review Board (MRB) actions for all in-house products decreased approximately 66%, while MRB actions on military products decreased over 90%. When looking at the impacts on cycle time, Company B has seen their manufacturing division shop lead-times reduced from 12.1 to 7.3 weeks. These benefits are highlighted in Table 3.

Table 3. Company B benefits.

Type of Action	Improvement
Mechanical inspection manpower	Decreased 44%
MRB actions for all products	Decreased 66%
MRB actions for military products	Decreased 90%
Manufacturing lead-times	Decreased from 12.1 to 7.3 weeks

Attempting to quantify the results of operator certification at Company C was extremely difficult. Defects decreased dramatically in the manufacturing line during the late 1960's, but that was after the line was restarted and total revamping of the design and manufacturing process had occurred. Operator certification was only one component of the whole process improvement.

The only way to attempt to quantify the results of operator certification at Company C, was to compare industrial engineering standards used prior to and after implementation for the same processes. A specific example is shown in Table 4. The tool load and unload time is 4.91 minutes, the total machine operation time is 3.82 minutes, total inspection time (operator inspected) 13.76 minutes, and machine time of 18.9 minutes, for a total of 41.49 minutes. Using a realization factor of 1.95, the allowed time is 80.91 minutes. If an inspector is required for the inspection operation, then that additional inspection time is 28.76 minutes. The new time allowed is 109.96. This is a change of approximately 35%. This is a significant time allowance, and only one of the many operations a part must go through during manufacturing and assembly. Since during the operation the operator was also checking the part (see Figures 1 and 2), the inspection time of 28.76 minutes was eliminated by the implementation of an operator self-inspection certification program.

Table 4. Example of time with and without an inspector.

Operation	Allocated Time (in minutes)
Tool Load/Unload	4.91
Machine Operation	3.82
Total Operator Inspection Time (Multiple Operations)	13.76
Machine Time	18.9
Total	41.49
Realization factor applied	80.91
Inspector	28.76
Total with Inspector	109.96

Implementation

There were several critical issues for successful implementation of an operator certification program. These were:

- Corporate commitment
- Management of the human interface
- Data management
- Labor and Defense Plant Representative Office (DPRO) buy-in

Corporate Commitment

There are several aspects to a successful program implementation which will be discussed as part of the corporate commitment. These are:

- Training
- Project coordinator
- Adequate funding

- Feasibility studies
- Pilot programs
- Long term dedication to the program

Training

One of the most emphasized aspects of a successful implementation of an operator certification program was training. All of the different roles involved in making the program a success required appropriate training to ensure that the needed skills were acquired. This study concluded that, from the operators who learn the proper inspection techniques, to the manufacturing engineers who write work instructions which call out inspectable characteristics, the training necessary to perform these skills were crucial to a company's successful implementation.

The following is an example of Company A's commitment, from their agreement between management and the union:

The purpose of having Certified Operators is to place the responsibility for product quality in the hands of the employees who perform the work.

In order to attain this end, the Company agrees to fully provide the necessary training so that employees can inspect, document, analyze, and produce defect-free products.³

At Company B, each person received a four and one half hour classroom familiarization course describing the operator self-inspection certification program, a one hour session describing proper procedures for use of the computer terminals, and as much on-the-job training as was needed for each individual. Operators were not certified until they passed a given number of audits, but they received as much on-the-job training as was necessary to reach that goal. In addition, each of the five different roles (manufacturing engineer/process planner, manufacturing supervisor, manufacturing operator, inspector, and quality assurance supervisor) received additional classroom training which was developed specifically for their job requirements. While

³ Sorenson, 1995.

the initial training sessions were taught by the project coordinator or one of the implementation team, effort was made to identify members of each manufacturing area who could perform the training needed for the rest of the workers in that area.

Project Coordinator

Another success factor was a dedicated project coordinator or implementation team. At Company B, an experienced employee was given the authority to implement the system without interference, and could make changes quickly when they were needed. The breadth of his/her personal work experience provided the coordinator insight into the following key areas: (1) the nature of the work done by the operators on the floor, (2) the management styles and pressures on the shop supervisors, and (3) the goals of the quality system. Since the program leader understood everyday activities in each of these key work groups, the types of pressures and resistance they would feel towards an operator certification system were understood. The program implementation team was formed in order to balance the skills available to successfully address the needs for system implementation.

Adequate Funding

Another important aspect for successful implementation was for each company to determine what funds were necessary to implement the operator self-inspection program, and allocate them fully. The salaries of the project coordinator and any implementation team members were accounted for, in addition to the training time for all workers (including fill-ins for on-shift training time) and all training materials needed. Another important budget item is any computer hardware or software that the company decides is necessary to successfully implement the program. These computer costs could include such items as operator work input terminals, bar code readers, a mainframe computer to host the program data, and any software necessary to organize the data input function for each of the system's users.

Feasibility Studies

Prior to instituting pilot programs to demonstrate the effectiveness of operator self-inspection in certain areas, the coordinator conducted feasibility studies in order to determine which aspects of known self-inspection programs would work within Company B, and which details would need modification. The feasibility study's role was to assess the issues associated with operator certification systems and determine what could be successfully implemented. Parts of the feasibility study included planning for implementation schedules, contingencies, benchmarking, and budget requirements. This study concluded that operator self-inspection must be tailored specifically to each work site. The needs of all of the stakeholders of the system were evaluated and allowed for within the self-inspection program. What worked at one company plant needed to be modified for another company (or even another plant within the same company) due to different concerns and work environments.

Pilot Programs

Another example of corporate commitment contributing to successful system implementation was pilot programs. Small trial areas were chosen to prove the process before it was implemented on a wider basis. What was noticed at Company B, was that each cell or plant had its own small pilot program in order to identify its unique aspects. The operator self-inspection program was never implemented plant or company wide. It appears that attention to differences within the plants or cells contributed to successful implementation at the company level. In each of these small test areas, the coordinator would make sure that any problems which came up were dealt with directly. As part of executing these pilot programs, an important trait was the willingness to modify the operator certification system if problems were discovered. The flexibility of the program implementor to consider several solutions when a problem arose seemed to be another important contributor to the success of the system. Making sure that "pride of authorship" and "not invented here" do not get in the way of evolving the system and were concluded to be as important to successful implementation as many of the technical

aspects. Careful selection of the implementation team is as important as determining which part characteristics should be inspected by the operators.

At Company B, specific areas were selected for the pilot program and initial implementation. These were usually one of three types:

- High volume machining operations;
- Certain processing operations, such as leak testing, balancing, or painting; and
- Production of high volume detail parts.

The implementation team arrived in the selected area, installed any necessary computer equipment (such as operator terminals), and then briefed the engineering personnel on how to provide accurate work instructions and why these were so important to the success of the operator certification program. The work instructions were converted to support the new inspection procedures, and then the formal training of all personnel associated with that process area began. The project coordinator was careful to identify one of the informal leaders within the operators and included that person in the initial training sessions. Once the training was completed, a tryout process was initiated in order to ensure work instructions, tools, and gages were accurate. It is important to note that Company B believed personnel must begin to use the skills associated with the operator certification program within 30 days of their initial training, or else retraining will be required. During the initial implementation in an area, not all manufacturing characteristics were immediately changed to accommodate operator self-inspection, but within 30 days, several characteristics were altered so that all workers could begin to use their self-inspection skills. Tailgate inspections were canceled after the findings correlated with the success of the self-inspection program. The decision to cancel the end-of-line inspections is one each company must make, based upon what they feel comfortable with.

Long term dedication to the program

At Company B and Company C, each person interviewed stressed the commitment to operator certification as a permanent process improvement, not as a short term cost savings program. At Company B, it was especially useful to compare and contrast the operator certification program which was unsuccessful in 1976 to the successful implementation starting in 1984. Several differences among the programs emerged. One difference was the successful implementation incorporated management commitment to providing workers with adequate work instructions and adequate training on inspection methods, equipment, and measuring devices. This furnished the operator with the necessary skills to perform successful inspections. Another difference in the implementation programs was the belief (described during employee interviews) that the successful system involved a corporate culture change about performing inspections. This centered around the commitment to increasing product quality, and the desire to detect of process errors when they occur and provide immediate feedback to the operators. A third difference in the two programs was, while Company B tried to implement the earlier system on a company-wide basis, the second operator self-inspection certification system was implemented using pilot programs in well-defined cells or manufacturing areas. These differences point towards effective use of management principles to ensure successful implementation of an operator self-inspection certification program.

Data Management

Computerization is not necessary in order to implement an operator certification system, but it facilitates the effectiveness. When all databases within a company can be linked, the advantage of the system is leveraged against the information it can provide. If possible, combining the necessary operator inputs into one computer screen facilitates their acceptance and does not appear to create any additional workloads.

Labor/DPRO Buy-in

At Company A, negotiations between the company and the union prior to implementation of operator inspection had determined that job loss would be minimized and that job classifications would be revised in order to facilitate saving jobs. As a result, the potential loss of inspection jobs due to operator certification were offset by an increase in responsibilities that were once in the domain of office employees.⁴

At Companies B and C, because the operator certification systems were implemented in the 1970's and 1980's, labor force buy-in was not as much of an issue as it was in the 1990's with declining aerospace production. Company B did not change their employees' job classifications at all. They stated that they were instituting a program which certified employees on tasks they already performed. The purpose of the system was to document the activities and train the employees properly. Company C, though, changed their operators' job descriptions.

When implementing the operator certification system, initially Company B had to work with the on-site government representatives and inspectors. The DPRO wrote inadequacy noncompliances against Company B, but the company was able to show how the system reduced risk on part quality and minimized wasted efforts. The resolution process included the system program office representatives from Wright-Patterson AFB in Ohio. Since Company B had tried to bring the Air Force into their plans for the program early, they were able to work through all of the issues in about one year. Once the Air Force was shown that the system met the goals of reduced risk and higher quality, they approved it.

At Company C, the DPRO had been involved from the start because of the quality problems they had encountered, forcing a shutdown of the production line. The DPRO monitored the implementation and were enthusiastic in their support, even though this was a revolutionary type of system. In fact, the DPRO explicitly pointed out during their interview that MIL-STD 9858A calls out the availability for the operator to inspect their own work in order to inspect a characteristic when it is generated instead of much later in the manufacturing process.

⁴ Sorenson, 1995.

Managing the human interface

Operator certification, by its name and nature, is a human-based change. This system changes the way people accomplish their work, as such, managing the human interface were concluded to be very important at each of the companies. When managed properly, this study found that the stakeholders' feel that they are being treated fairly and believe that they have a voice in the success of the new system. The workers need to feel that conflict of interest issues are addressed. Company B exhibited their sensitivity to this issue of fairness when planning how to address disagreements which arose over an inspection. Since the parties involved (operator and quality inspector) were not included in the investigative process, the stakeholders felt that their concerns had been taken into account and the judgment would be unbiased.

Another specific example of the important role of managing this interface is the way Company B designed the operator's escape code for the certification system. Knowing that there would be times when operators would at least perceive pressure from their shop supervisor to "move parts along," the escape code allows for the operators to maintain their inspection integrity, without disobeying their supervisor. This addressed the work "reality" of producing as many parts as possible for the shop supervisor, while dealing with the operator's desire to not "get busted down" any levels in the inspection system by having an audit show his/her inspection of those parts were sub-standard. This, in essence, gave the operator the authority to perform his/her job correctly.

Another specific example of managing the interface was the appointment of the project coordinator at Company B. They were able to find one person who had experience working in the areas of most of the stakeholders. He had worked on the floor, as a shop supervisor, and as a quality assurance representative. This allowed the coordinator to understand the concerns of many of the stakeholders.

Conclusion

When reviewing the different systems it is clear that there is not one successful way to implement the system, but several. An operator inspection system can be implemented at any company, but must be tailored to their specific needs. It can be computerized or manual; it can stand-alone or be fully incorporated into other systems or databases. What must be noted are the themes which are common among each of the different systems.

This study found that operator certification systems worked at these companies because part quality is stressed as absolutely critical. Corporate emphasis has been placed on the need to build parts of the highest quality. The companies recognized the need to isolate mistakes at the time they were created as opposed to allowing them to travel down the manufacturing line and accumulate potential wasted efforts.

Another common theme was the interactions between engineering and manufacturing operations. The companies are aware that operators cannot inspect characteristics if the engineering design does not call them out appropriately. Recognizing that they must facilitate the interaction among these two groups, each company implemented different degrees of communication enablers, but they recognized the need for communication to be free-flowing and encouraged. Design for manufacture might be a recent concept, but two of these companies have been practicing it for 15-20 years.

As stated in the beginning of the case study, the objectives of the operator self-inspection program are:

- Provide immediate detection of man, machine, and process errors,
- Provide an alternative to 100% in-line inspection by quality control personnel,
- Provide greater incentive to manufacturing personnel to identify part status accurately, and
- Provide positive feedback to operators to prevent errors from re-occurring.

These objectives were met by both companies who successfully implemented the program, and are in process at Company A.

Once a company decides to pursue an operator self-inspection strategy, the steps taken during the implementation of the program will determine its success. The enablers which seemed

to be common in each of the companies which continue to enjoy successful operator self-inspection are:

- corporate commitment,
- successfully managing the human to operator certification interface,
- data management, and
- labor and DPRO buy-in.

As a concluding message to all organizations which intend to pursue the implementation of operator self-inspection, it was apparent from the attitude of each employee that this type of program represents a culture change within an organization. While the potential benefits from this type of inspection system are enormous, these cannot be realized in short time spans. They require many years and a corporate commitment to changing the basic understanding of how quality is ensured and risk is minimized in an operator certification environment.