

# A Miniature Airborne Particle Classifier (APC)

C. Stopford, P. H. Kaye, E. Hirst, Z. Ulanowski

Centre for Atmospheric & Instrumentation Research, University of Hertfordshire, Hatfield, Hertfordshire, AL10 9AB.  
+441707 284174, c.stopford@herts.ac.uk

## Introduction

The single greatest source of uncertainty in the estimates of climate sensitivity to either natural or man-made changes continues to be clouds (IPCC 2001, 2007). Much of this uncertainty arises from the lack of information relating to the properties of smaller cloud particles (droplets, ice crystals) and aerosol.

The Particle Instruments & Diagnostics research group at the University of Hertfordshire has a successful history of developing laboratory and airborne particle counting and classification instruments – in particular the Small Ice Detectors Mk.1, 2, and 3. (Fig.1 below).

These instruments are mounted under an aircraft wing in a standard PMS™ canister and capture two dimensional scattering patterns from individual particles down to a few micrometres in size. This information can then be used to assess the size, shape and class of particles in the cloud.

Since competition for PMS berths is intense on most research aircraft, this NERC-funded project seeks to develop a miniature version of the SID-2 probe to allow it to be flown on a far wider range of aircraft – including UAVs.

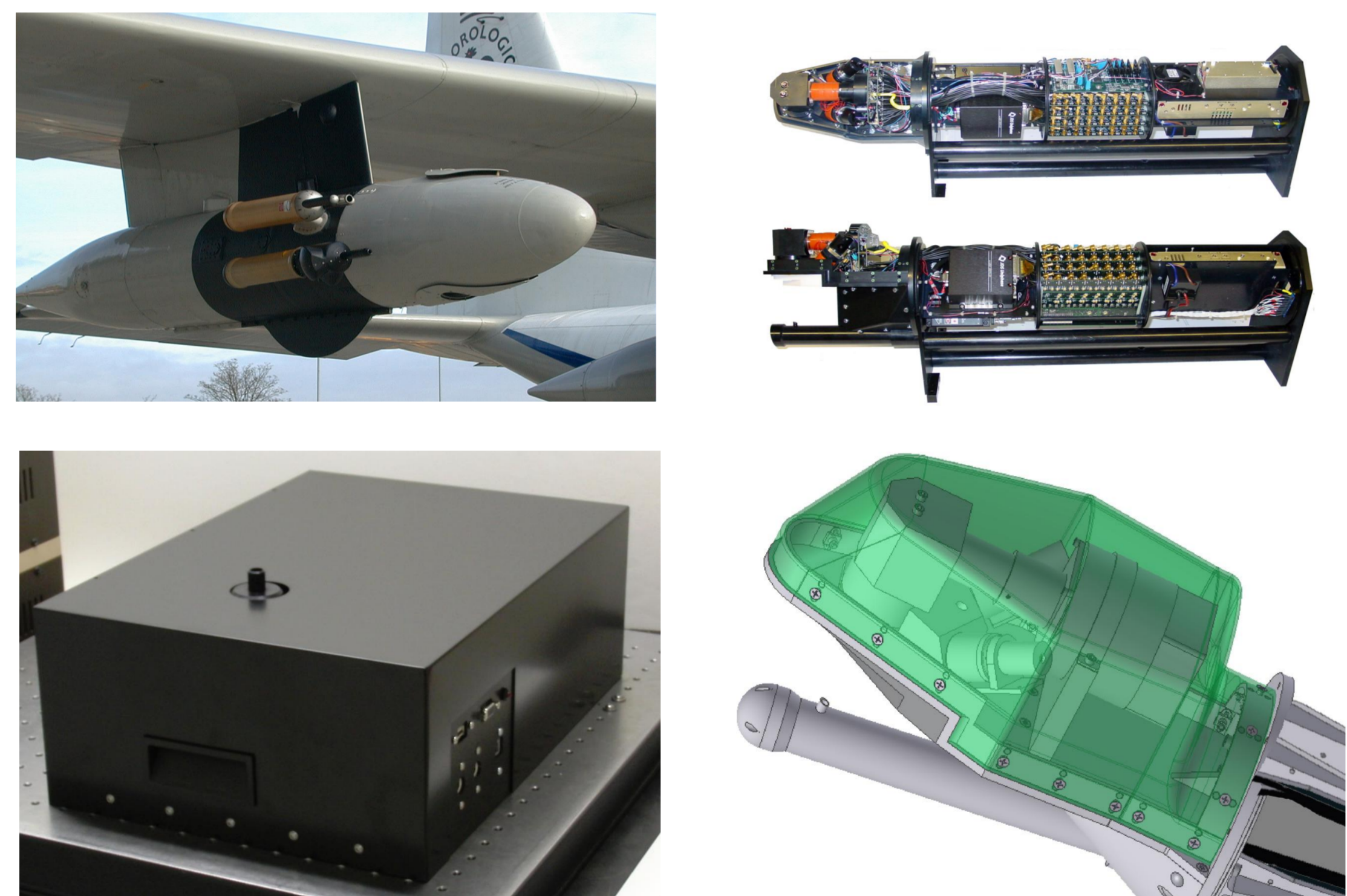
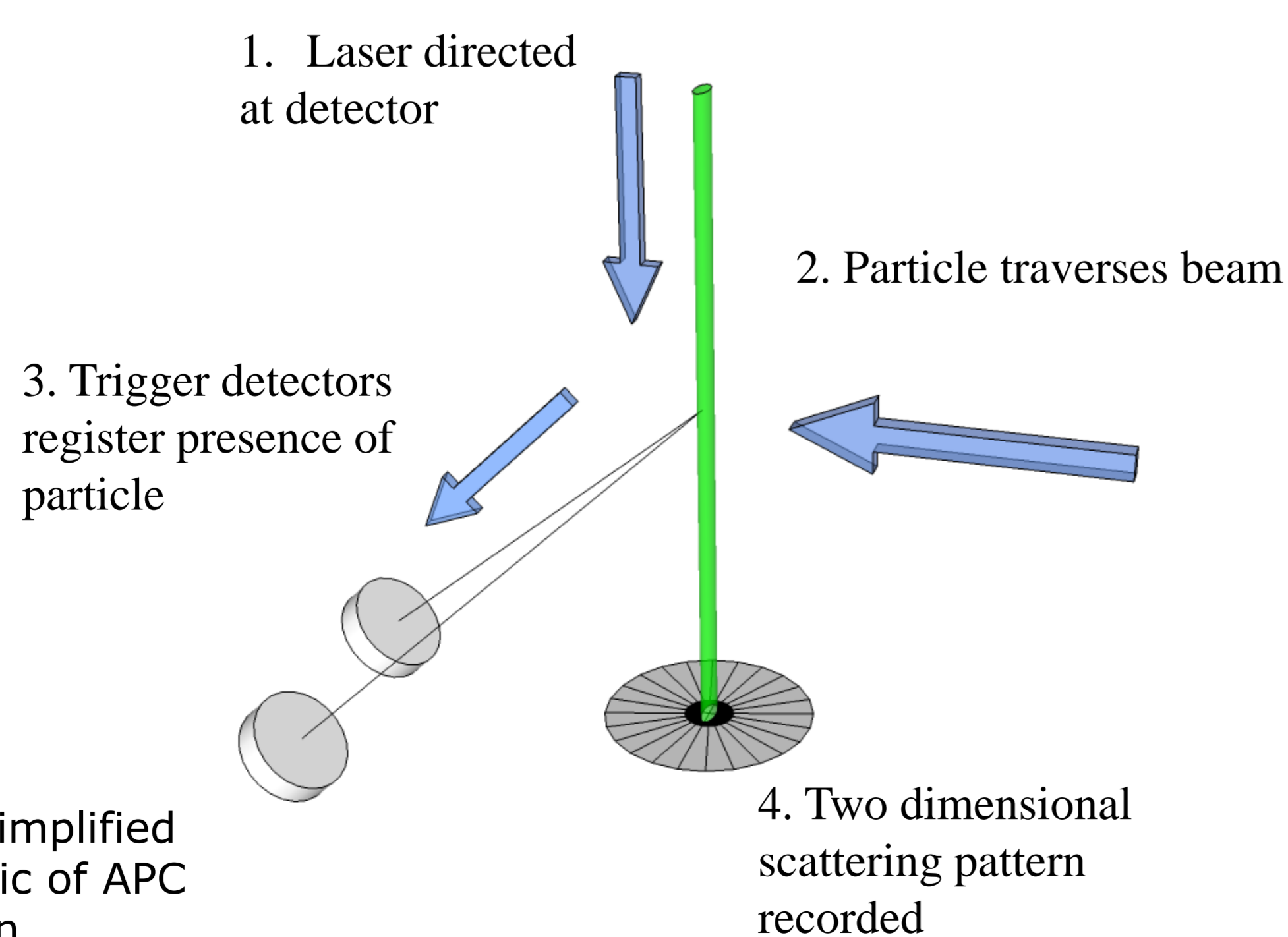

**Fig.1:** Clockwise from top-left: SID1 probe on C130 aircraft; SID2 probe; SID3 high-resolution scattering probe; PPD1 lab-version of SID3 probe for cloud-chamber and related studies.

## APC Concept

Particles entering the instrument traverse a laser beam, as in Fig.2. A small volume at the centre of the beam path is defined optically by two 'trigger' detectors. When a particle traverses this volume, the detectors register its presence and initiate the capture of detailed spatial light scattering data by a main multi-pixel sensor.

The scattering data are then passed to an inboard computer to be displayed to an operator and saved for later analysis.



**Fig.2:** Simplified schematic of APC operation.

## Miniaturisation

Currently, detailed design work is underway to implement the SID technology in a suitably robust but miniaturised instrument that could attach directly to a mounting point on the aircraft fuselage or wing (Fig.3 below). The primary objective is to reduce the weight to around 3Kg and power consumption to the order of 300W, with the majority of the required opto-electronics contained in the instrument. A small single board computer will be used to save data, although modification to transmitted data would be feasible. The instruments aerodynamic case has internal heating to compensate for low ambient temperatures and flow channels to protect optical surfaces from water saturation.

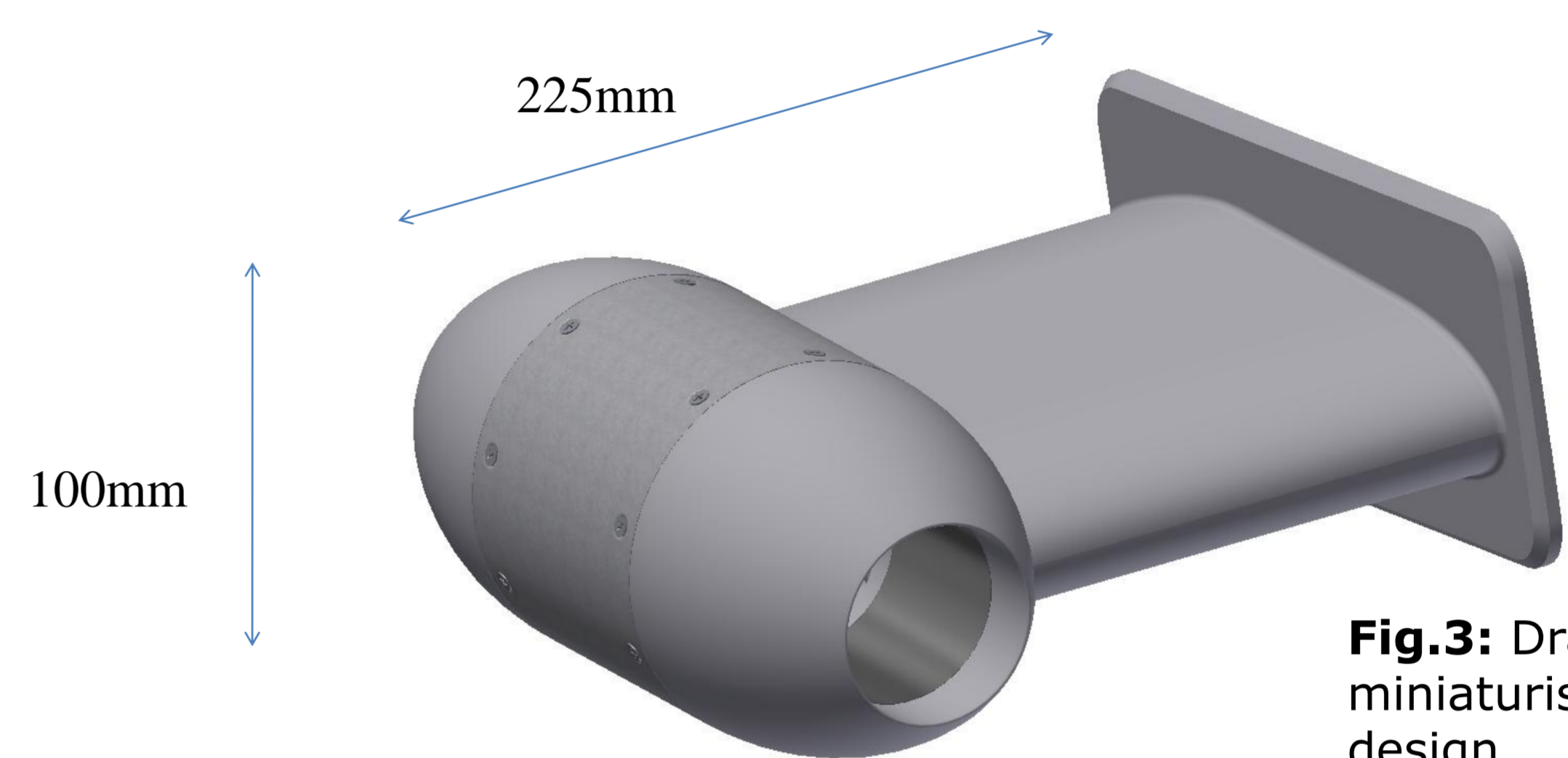

**Fig.3:** Drawing of miniaturised probe design

## Exemplar Data

Fig.4, below, illustrates typical particle data acquired by a SID2 instrument (polar plot, red line), and SID3 (high-res 2D scattering image). The APC will function as a hybrid of the high-speed but low resolution SID2 instrument and the low-speed but high-resolution SID3. By allowing light scattering data capture from up to several thousand particles per second (as does SID2), but at a resolution approaching that of the SID3 (though limited to specific spatial regions of interest), it is hoped the APC will provide a powerful and versatile means of characterising statistically significant numbers of cloud particles in terms of size, shape, surface structure, and potentially internal structure (for example, droplets containing black carbon particles).

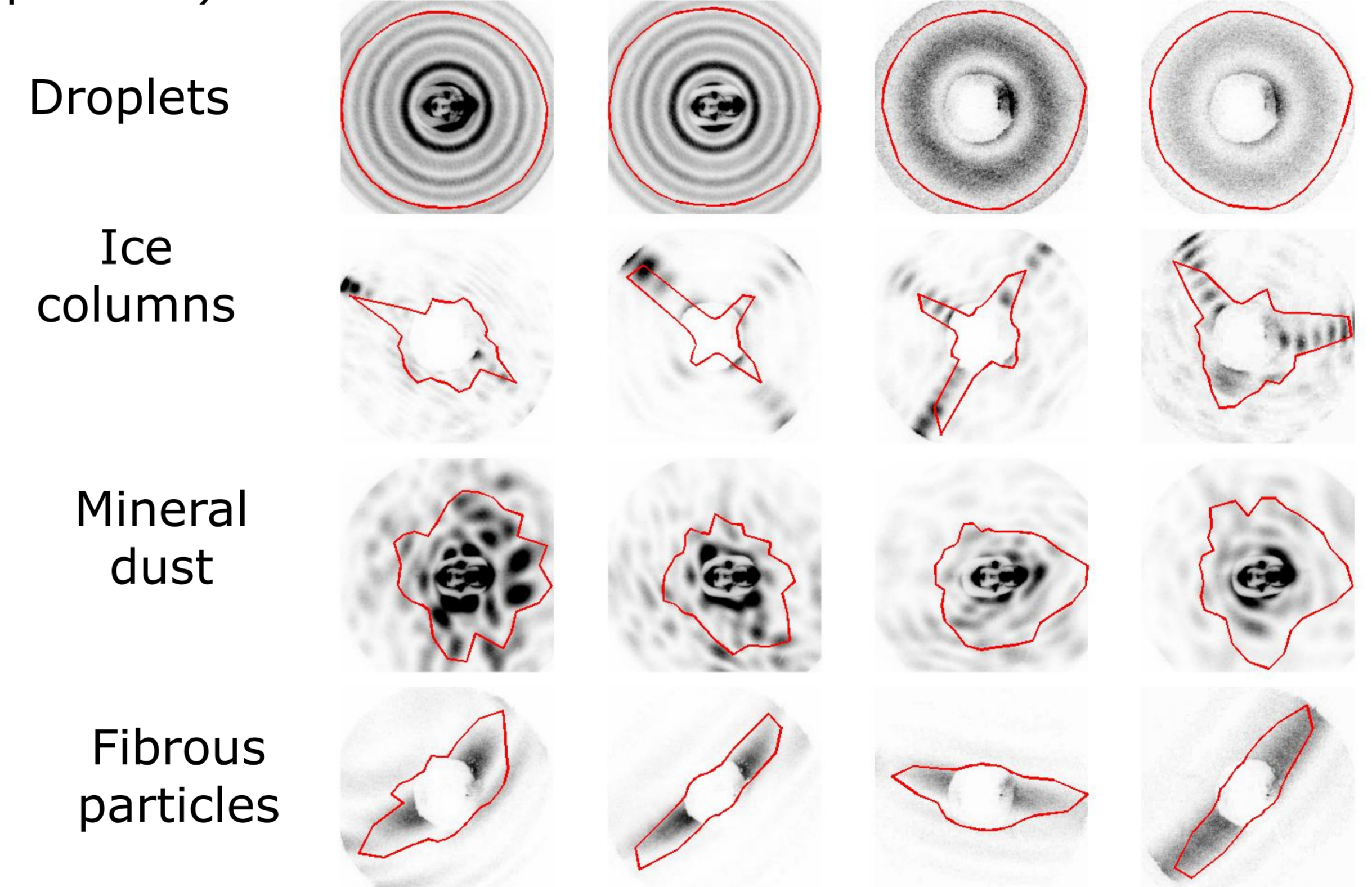

**Fig.4:** Examples of particle data captures by the SID2 (red line) and SID3 (2D-images) probes. The APC will combine both techniques to yield detailed morphological data from large number of individual particles down to micrometre sizes.

## Summary

Particle classification probes designed at the University of Hertfordshire have been successfully applied in cloud microphysics campaigns and cloud chamber experiments to classify ice crystals and other atmospheric particles. The new miniaturised version, the APC, will hopefully allow a significantly wider variety of aircraft platforms (including UAV's) to be engaged in these important atmospheric measurements.

## Acknowledgements

This work was funded by an award from the Natural Environment Research Council (NE/H002316/1).