

Characterisation of α -dystrobrevin in muscle

Ralph Nawrotzki^{1,*}, Nellie Y. Loh¹, Markus A. Ruegg², Kay E. Davies^{1,†,§} and Derek J. Blake¹

¹Genetics Unit, Department of Biochemistry, University of Oxford, South Parks Road, Oxford, OX1 3QU, UK

²Department of Pharmacology, Biozentrum, University of Basle, CH-4056 Basle, Switzerland

*Present address: Max-Planck-Institut fuer Biochemie, Abteilung Proteinchemie, D-82152 Martinsried bei Muenchen, Germany

†Present address: Department of Human Anatomy and Genetics, University of Oxford, South Parks Road, Oxford, OX1 3QX, UK (e-mail: kdavies@bioch.ox.ac.uk)

§Author for correspondence

Accepted 1 July; published on WWW 13 August 1998

SUMMARY

Dystrophin-related and associated proteins are important for the formation and maintenance of the mammalian neuromuscular junction. Initial studies in the electric organ of *Torpedo californica* showed that the dystrophin-related protein dystrobrevin (87K) co-purifies with the acetylcholine receptors and other postsynaptic proteins. Dystrobrevin is also a major phosphotyrosine-containing protein in the postsynaptic membrane. Since inhibitors of tyrosine protein phosphorylation block acetylcholine receptor clustering in cultured muscle cells, we examined the role of α -dystrobrevin during synapse formation and in response to agrin. Using specific antibodies, we show that C2 myoblasts and early myotubes only produce α -dystrobrevin-1, the mammalian orthologue of *Torpedo* dystrobrevin, whereas mature skeletal muscle expresses three distinct α -dystrobrevin isoforms. In myotubes, α -dystrobrevin-1 is found on the cell surface and also in acetylcholine receptor-rich domains. Following agrin

stimulation, α -dystrobrevin-1 becomes re-localised beneath the cell surface into macroclusters that contain acetylcholine receptors and another dystrophin-related protein, utrophin. This redistribution is not associated with tyrosine phosphorylation of α -dystrobrevin-1 by agrin. Furthermore, we show that α -dystrobrevin-1 is associated with both utrophin in C2 cells and dystrophin in mature skeletal muscle. Thus α -dystrobrevin-1 is a component of two protein complexes in muscle, one with utrophin at the neuromuscular junction and the other with dystrophin at the sarcolemma. These results indicate that α -dystrobrevin-1 is not involved in the phosphorylation-dependent, early stages of receptor clustering, but rather in the stabilisation and maturation of clusters, possibly via an interaction with utrophin.

Key words: Dystrobrevin, Utrophin, Agrin, Acetylcholine receptor (AChR) clustering, Muscle

INTRODUCTION

A key event in the formation of synapses is the accumulation of neurotransmitter receptor proteins at the postsynaptic membrane, directly opposite the presynaptic nerve terminal. During the development of the neuromuscular junction (NMJ), the nicotinic acetylcholine receptor (AChR) undergoes a dramatic relocalisation and aggregates at high density in the plasma membrane juxtaposed to the nerve terminal (Hall and Sanes, 1993). The innervating motor nerve regulates this accumulation through synapse-specific induction of gene expression and via post-translational mechanisms (Duclert and Changeux, 1995). The extracellular matrix (ECM) protein agrin is involved in the post-translation clustering of AChRs and also plays a role in the induction of synapse-specific gene expression (reviewed by Ruegg and Bixby, 1998).

Members of the dystrophin-associated protein complex (DPC) and dystrophin-related proteins have been implicated in synaptic structure and function. The dystrophin-deficient *mdx* mouse has an increase in the rate of AChR degradation similar to that observed following denervation (Xu and Salpeter, 1997). These mice also have morphologically abnormal NMJs,

characterised by a reduction in the number of junctional folds (Lyons and Slater, 1991). The dystrophin-associated protein, α -dystroglycan, is the major agrin-binding protein in muscle and other tissues; however, α -dystroglycan is unlikely to be a functional agrin-receptor (Meier et al., 1996; Gesemann et al., 1998). Although the absence of dystrophin results in loss of the DPC from the extra-synaptic sarcolemma, dystrophin-associated proteins are still retained at the NMJ through an association with the dystrophin-related protein, utrophin (Matsumara et al., 1992). In normal adult muscle utrophin is found exclusively at the NMJ (Ohlendieck et al., 1991). Similar to the *mdx* mouse, utrophin-deficient mice have a reduction in the number of junctional folds at a single synapse (Deconinck et al., 1997; Grady et al., 1997). Thus, the specialised postsynaptic cytoskeleton of the NMJ appears to contain a modified DPC that is required to maintain normal synaptic structure.

To determine the function of other dystrophin-related proteins at the synapse, we have focused our studies on α -dystrobrevin (also known as 87K protein or A0). Dystrobrevin was originally identified in the *Torpedo* electric organ as a component of the postsynaptic membrane that co-purified with

the AChRs, rapsyn, syntrophin and dystrophin (Carr et al., 1989; Butler et al., 1992; Wagner et al., 1993; Kramarcy et al., 1994; Dwyer and Froehner, 1995). Although α -dystrobrevin is closely associated with the AChRs, monoclonal antibodies raised against this protein label the sarcolemma as well as the NMJ of rodent skeletal muscle (Carr et al., 1989). Interestingly, dystrobrevin is a dystrophin-related protein that is phosphorylated on tyrosine and serine residues, suggesting that its function may be regulated by post-translation modification (Wagner et al., 1993; Wagner and Haganir, 1994).

By contrast to the initial description of dystrobrevin in *Torpedo*, we have shown that several α -dystrobrevin isoforms are expressed in different mouse tissues (Blake et al., 1996; Ambrose et al., 1997). In skeletal muscle these are: α -dystrobrevin-1 (94 kDa), α -dystrobrevin-2 (62 kDa) and α -dystrobrevin-3 (42 kDa), described herein. α -dystrobrevin-1 is the orthologue of the *Torpedo* 87K protein and contains a ZZ domain (Ponting et al., 1996), two predicted α -helical coiled-coil motifs (Blake et al., 1995) and a C-terminal tyrosine kinase substrate domain (Wagner et al., 1993; Blake et al., 1996). Alternative splicing in cardiac and skeletal muscle generates α -dystrobrevin-1 and -2 transcripts that differ from their brain counterparts by the inclusion of the vr3 sequence preceding the coiled-coil encoding region (Blake et al., 1996; Ambrose et al., 1997). It has been established that α -dystrobrevin binds to syntrophin and dystrophin in different tissues (Kramarcy et al., 1994; Blake et al., 1996; Peters et al., 1997a). However, the antibodies used in these studies do not distinguish between α -dystrobrevin-1 and -2, and the recently identified paralogue, β -dystrobrevin (Peters et al., 1997b; Blake et al., 1998). Thus, the exact protein interactions involving dystrobrevin isoforms have not yet been elucidated.

Since α -dystrobrevin is known to be associated with AChRs and is also thought to be part of the DPC, we have studied the role of the different α -dystrobrevin isoforms during synapse formation and in normal muscle. We have identified three different α -dystrobrevin isoforms that are expressed in mature skeletal muscle. Using α -dystrobrevin-1 specific antisera, we show that α -dystrobrevin-1 is localised at the sarcolemma and NMJ of normal muscle but is restricted to the NMJ in dystrophin-deficient *mdx* muscle. In cultured myotubes, α -dystrobrevin-1 is distributed on the cell surface but is enriched in AChR-containing clusters. Following agrin stimulation, α -dystrobrevin-1 is dramatically re-localised into AChR-containing macroclusters. However, agrin stimulation does not induce tyrosine phosphorylation of α -dystrobrevin-1, in contrast to nicotinic AChRs (Wallace et al., 1995). α -dystrobrevin-1 co-immunoprecipitates with utrophin in myotubes and with dystrophin in adult skeletal muscle. We conclude that α -dystrobrevin-1 is a component of two protein complexes, one with dystrophin at the sarcolemma and one with utrophin at the NMJ. α -dystrobrevin-1, in association with utrophin, may be involved in the maturation of the postsynaptic cytoskeleton at the developing NMJ.

MATERIALS AND METHODS

Molecular biology

The human dystrobrevin-3 cDNA clones were isolated from a human foetal brain cDNA library prepared in the plasmid vector pcDNA2

(Invitrogen) as described previously (Blake et al., 1996). The murine dystrobrevin-3 cDNAs were isolated from muscle first-strand cDNA by reverse-transcriptase PCR using the following primers: PSP3F 5'-CTGTAACCAGCATGAACGAC and PSP3.1R 5'-CAGCTTTAT-TGAACAGCACCC, with Pfu polymerase (Stratagene), following the manufacturer's instructions. PCR products were incubated with Taq polymerase (Perkin Elmer) for 30 minutes at 72°C, purified and subcloned in to pGEM-T (Promega). Multiple clones were sequenced with Sequenase version 2.0 (Amersham) to check for mutations that may have occurred during PCR. Human multiple tissue northern blots were purchased from Clontech and hybridised following the manufacturer's instructions.

Antibodies

The following primary antibodies used in our experiments have been described previously or are available commercially: horseradish peroxidase (HRP)-conjugated anti-phosphotyrosine mAb 4G10 (Upstate Biotechnology), polyclonal anti-dystrophin P6 antiserum (Sherratt et al., 1992), anti-utrophin monoclonal antibody (mAb) MANCHO3 (Nguyen et al., 1991), anti- β -dystroglycan mAb 43DAG1/8D5 (NovoCastra), anti-vimentin/desmin mAb IFA (Pruss et al., 1981), polyclonal anti-MuSK Nsk2Fc antiserum (Meier et al., 1997). In addition, we used an anti- α -dystrobrevin-1 (α 1CT-FP) polyclonal antiserum that was generated against a fusion protein containing 107 amino acids of the unique carboxy terminus of α -dystrobrevin-1 and an anti- β -dystrobrevin (β CT-FP) polyclonal antiserum that was generated against a fusion protein containing the last 306 amino acids of β -dystrobrevin (Blake et al., 1998). In muscle the β CT-FP polyclonal only detects α -dystrobrevin-1 and -2 (Blake et al., 1998).

Agrin and peroxivanadate

The generation of recombinant agrin is described elsewhere (Gesemann et al., 1995). Agrin treatment of day-6 myotubes was performed by washing cells once in pre-warmed differentiation medium, and incubating them at 37°C in differentiation medium supplemented with C95_{A4B8} agrin. Incubation times were 16 hours in clustering experiments and shorter periods for the analysis of tyrosine phosphorylation (see Fig. 7). 1 nM C95_{A4B8} agrin was used for clustering experiments and 10 nM C95_{A4B8} agrin for phosphotyrosine experiments. Control experiments were performed in parallel using 1 nM C95_{A0B0}, the clustering-deficient agrin isoform, or no agrin. Sodium peroxivanadate was prepared by mixing 100 μ l of 100 mM sodium pervanadate and 200 μ l of 100 mM H₂O₂ and diluting it into 9.7 ml serum-free medium immediately before use. Cultures were washed once with serum-free DME medium and treated with peroxivanadate for 15 minutes.

Cell culture

C2C12 mouse muscle cells (Yaffe and Saxel, 1977) were routinely cultured in 175 cm² tissue culture flasks in DMEM supplemented with 10% foetal calf serum (Globofarm Ltd.), glutamine and antibiotics. For immunofluorescence studies, cells were transferred onto gelatine-coated coverslips and stained as described below. For biochemical experiments, cells were cultured in the original 35 mm dish and processed as described below. Myoblast fusion was induced by culturing the cells in DMEM supplemented with 5% horse serum, glutamine and antibiotics (differentiation medium). Early myotubes appeared within 3 days, late myotubes after 6 days.

Immunofluorescence microscopy

8 μ m cryosections, prepared from adult skeletal muscle of normal C57 and *mdx* mutant mice as described previously (Deconinck et al., 1997), were stained as described below. Cells growing on coverslips were rinsed in phosphate-buffered saline (PBS), and fixed for 20 minutes at room temperature in PBS containing 1% paraformaldehyde, 100 mM L-lysine, 10 mM sodium metaperiodate

and 0.1% saponin. After rinsing in PBS, cells were permeabilized for 10 minutes in PBS containing 1% Triton X-100, washed three times in PBS and stored overnight at 4°C in PBS. All subsequent steps were carried out at room temperature. Coverslips were incubated for 1 hour in blocking buffer (PBS containing 5% fraction V bovine serum albumin, 5% fetal calf serum and 0.1% sodium azide) followed by 1 hour incubation with the primary antibody. The antibody dilutions were 1:500 for the α 1CT-FP and β CT-FP polyclonal antisera, and 1:100 for the P6 polyclonal antiserum and for mAbs MANCHO3 and 43DAG1/8D5. Coverslips were washed three times for 10 minutes in PBS, and incubated for 1 hour with affinity-purified FITC-conjugated donkey anti-mouse or anti-rabbit IgG (diluted 1:100; Jackson ImmunoResearch Laboratories, Inc.). After three washes in PBS, coverslips were incubated for 1 hour with rhodamine-conjugated α -bungarotoxin (diluted 1:3000; Molecular Probes, Inc.), followed by three washes in PBS and mounting in Vectashield mounting medium (Vector Laboratories). Labelled cells were analysed and photographed on a Leica DM RBE Microscope using N FLUOTAR 40 \times lenses. Negative control experiments were performed with rabbit pre-immune serum (diluted 1:500) or without primary antibodies alone.

Immunoprecipitation

Immunoprecipitation experiments were carried out on C2 cell lysates prepared from 100 mm tissue culture dishes. Cells were rinsed with ice-cold PBS and incubated for 15 minutes on ice in 1 \times RIPA buffer (500 mM NaCl, 50 mM Tris, pH 7.4, 1% Triton X-100, 1% sodium deoxycholate, 0.1% SDS, 1 mM sodium orthovanadate, 1 μ g/ml leupeptin, 1 μ g/ml aprotinin and 10 μ g/ml pepstatin) or lysis buffer for phosphotyrosine experiments (150 mM NaCl, 50 mM Tris, pH 7.5, 5 mM EDTA, 5 mM EGTA, 50 mM NaF, 10 mM sodium molybdate, 1% Triton X-100, 1 mM sodium orthovanadate, 1 μ g/ml leupeptin, 1 μ g/ml aprotinin and 10 μ g/ml pepstatin). The subsequent steps were carried out at 4°C. Cell lysates were collected, sonicated three times for 10 seconds, and centrifuged at 20,000 g for 15 minutes to remove insoluble material. For immunoprecipitation, 0.5–1 mg of soluble protein was incubated overnight with 2 μ l α 1CT-FP antiserum or 2 μ l anti-MuSK antiserum, followed by recovery with protein A-Sepharose (Pharmacia) for 1 hour at 4°C. Sepharose-pellets were washed three times in 1 \times RIPA buffer containing 1% Triton X-100, and once in PBS. Proteins were eluted from protein A-Sepharose with urea/SDS buffer (75 mM Tris, pH 6.8, 3.8% SDS, 4 M urea, 5% β -mercaptoethanol, 20% glycerol) and analysed by western blotting. Control experiments were performed with 2 μ l pre-immune serum or without antiserum. α -dystrobrevin-1 and dystrophin were co-immunoprecipitated from 500 μ g of RIPA-solubilised mouse muscle protein as described above.

Immunoblot analysis

Proteins were separated by electrophoresis on 8% SDS-polyacrylamide gels and electrophoretically transferred onto nitrocellulose membranes (Schleicher und Schuell). The following steps were carried out at room temperature. Membranes were incubated for 1 hour in blocking buffer (Tris-buffered saline containing 0.1% Tween-20 and 5% non-fat dry milk, or 3% fraction V bovine serum albumin instead of dry milk for phosphotyrosine experiments), and incubated for 1 hour with the following primary antibodies; mAb 4G10 (1:5000), P6 polyclonal antiserum (1:1000), α 1CT-FP polyclonal antiserum (1:500), β CT-FP polyclonal antiserum (1:1000), mAbs MANCHO3 and IFA (1:100), mAb 43DAG1/8D5 (1:20). Membranes were washed three times for 10 minutes in blocking buffer and incubated for 1 hour with HRP-conjugated donkey anti-mouse or anti-rabbit IgG (diluted 1:3500; Jackson ImmunoResearch Laboratories, Inc.). Western blots were developed with the BM chemiluminescence substrate system according to the manufacturer's instructions (Boehringer-Mannheim).

RESULTS

Dystrobrevin isoforms in muscle

Previously we have described the two dystrobrevin isoforms, α -dystrobrevin-1 and -2 in mouse brain (Blake et al., 1996). Hybridisation of a probe derived from the 5' end of the dystrobrevin cDNA to multiple tissue northern blots shows a complex pattern of transcripts in different tissues (Fig. 1A, upper panel). In skeletal and cardiac muscle the most intensely hybridising transcript is 1.7 kb. This transcript does not correspond to the α -dystrobrevin-1 and -2 mRNAs (Blake et al., 1996; Ambrose et al., 1997). To complete our description of α -dystrobrevin isoforms in muscle we cloned the human and mouse cDNAs corresponding to the 1.7 kb muscle-expressed transcript. The protein product of this transcript has been named α -dystrobrevin-3. A northern blot was hybridised with a probe covering the unique 3' untranslated region of α -dystrobrevin-3 and shows that α -dystrobrevin-3 is only expressed in skeletal and cardiac muscle.

Conceptual translation of the α -dystrobrevin-3 cDNA predicts a protein with a relative molecular mass of 42 kDa (Fig. 1B). α -dystrobrevin-3 has a unique 9-amino-acid C-terminal sequence and a short 3' untranslated region. The predicted α -dystrobrevin-3 protein contains two structural motifs that are characteristic of the dystrophin-family of related proteins, namely the EF-hands and ZZ domain (Ponting et al., 1996; Roberts and Bobrow, 1998). These structural features are conserved amongst the dystrophin-related proteins in vertebrates and invertebrates and can therefore be predicted to be functionally important (Roberts and Bobrow, 1998). The primary sequences of human and mouse α -dystrobrevin-3 are highly homologous, differing at only four residues. However only one of these residues is in the unique C-terminal encoding region of α -dystrobrevin-3. The remainder of the sequence of α -dystrobrevin-3 is identical to the common regions of α -dystrobrevin-1 and -2. No murine expressed sequence tags (EST) were identified that were identical or homologous to the unique region of α -dystrobrevin-3, which is encoded by exon 11 (Ambrose et al., 1997). The human α -dystrobrevin-3 specific sequence described herein, and previously by Sadoulet-Puccio et al. (1996), also has no EST homologue, despite its abundance in muscle and proximity to the 3' end of the mRNA.

The sequences of the 3' untranslated regions of human and mouse α -dystrobrevin-3 are homologous (Fig. 1C). Interestingly, our results obtained by northern blotting show that α -dystrobrevin-3 is encoded by a single transcript whereas α -dystrobrevin-1 and -2 are encoded by a least two different transcripts (Blake et al., 1996; Ambrose et al., 1997). The organisation of each of the α -dystrobrevin isoforms expressed in muscle is shown in Fig. 1D.

α -dystrobrevin-1 is a dystrophin-associated protein in skeletal muscle

Since α -dystrobrevin-1 is the mammalian orthologue of the *Torpedo* 87K protein (Wagner et al., 1993) we used a specific antibody, α 1CT-FP (Blake et al., 1998), to determine the location of α -dystrobrevin-1 in muscle. This study differs from previously described experiments that did not use isoform-specific antisera. Frozen sections of normal mouse

A

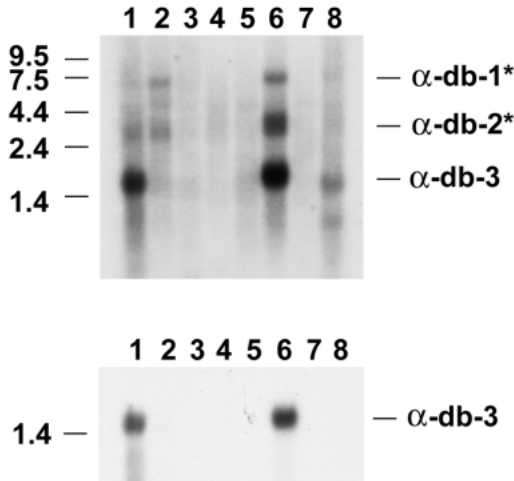

C

Human TCGGACGGTGTCTTTGGTGGATGCGCTCTAGATGGATAACATGACTTCTTC
 |||||
 Mouse TCGGACGGCGCCCATGGTGGATGCGCTCTAGATGGATAACATGACTTCCTG
 |||||
 TACCCTAAAATATTCTATAATACTTTGAGCTGTTCTGGTTCCTCCAGGG
 |||||
 TTCCCTAAAATATTTCTA.AACCCTTGAGCT.TTCTGCTTCT.....
 TGCATGGTACCCATTAACCCAAAATATGATTATTTCCCTTTTTCCTCC.AT
 |||||
CTATTAACCAAGAGTTGAGTTGCTTCCCTTTCTTCCCAAT
 TTTTCAGTCATTTTGGAAATGTTCTCTGTAACCCAGTTGTTGTTGTTAA
 |||||
 TTTTCAGTCTCTTGTCTTGTTCCTGTGAACCCAGAT...TTCTATAAA
 GCTCACAATTTCTTTCTGTCAACACAGAGATTGGCCTACGGTTTCTGTTTT
 |||||
 TCTTGTGGTCT...TATCACTGTCAAGACTGGGCTTTACTTTCTGTTTT
 GAGGGTGTCTGTTT AATAAA GCTGTGTACACTAAAAA
 |||||
 TAGGGTGTCTGTTT AATAAA GCTG

D

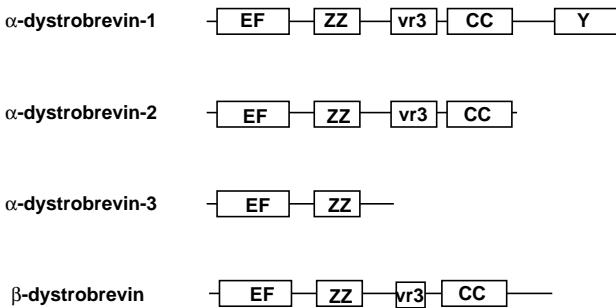

muscle were stained with α 1CT-FP, which is raised against the unique carboxy terminus of α -dystrobrevin-1 (Blake et al., 1998). α -dystrobrevin-1 was localised at the entire circumference of the sarcolemma and enriched at the NMJ (Fig. 2). However, when muscle sections from the dystrophin-

B

AGCGGACCCGGCACTTCCAACATTAATTAATAAAGAAAGGGCTCCACTCAGGCACAA
 ACCTCCCTGCAGACCAATGGACGCCTTCTAGAGTTTGGGAGTCAGTACTGAAGCGCC
 CGTCCATTTCCAAGATAAATAGGATTTACCAATCCTTGGATGAAGTCTTGGGAAGTCTTT
 AAGTGCCATAATCAACTGCCATTTCAAAGAAATATAGATGGTTTGGAAAGTTTCACTGCTGT
 CCCTTCATGAATTTTGAAGATAGTGGGAAAGAGGAAATACCATGCCAGA
 M I E D S G K R G N T M A E
 Human
 Mouse
 AAGAAGACAGCTGTTTGCAGAGATGAGGGCTCAAGATCTGGATCGCATCCGACTCTCCAC
 R R Q L F A E M R A Q D L D R I R L S T
 CTACAGAACAGCATGCAAGCTTAGGTTTGTTCAGAAGAAATGCAATTTGCACCTGGTGA
 Y R T A C K L R F V Q K K C N L H L V D
 CATATGGAATGTCATAGAAGCATTGCGGAAAATGCTCTGAACAACCTGGACCCAAACAC
 I W N V I E A L R K N A L N N L D P N T
 TGAACCTCAACGTGTCCTGGTGGAGGCTGTGCTCTCCACTATTTTACCAGCTCAACAA
 E L N V S R L E A V L S T I F Y Q L N K
 ACGGATGCCAACCACTCACCAAATCCATGTGGAGCAGTCCATCAGCTCTCTTAACTT
 R M P T T H Q I H V E Q S I S L L L N F
 CCTGCTTGCAGCGTTTGTATCCGAAGGCCATGTTAAATTTTCAATTTGCTGTCAAAT
 L L A A F D P E G H G K I S V F A V K M
 GGCTTTAGCCACATTTGTGGAGGGAAGATCTGGACAATTAAGATATATTTTCTCAAT
 A L A T L C G G K I M D K L R Y I F S M
 GATTCTGACTCCAGTGGGGTATGGTTTATGGACGATATGACCAATTCCTTCGGGAAGT
 I S D S S G V M V Y G R Y D Q F L R E V
 TCTCAAACCTCCACGGCAGTTTGAAGTCTTCAATTTGGTTACACAGAACAGTCAAG
 L K L P T A V F E G P C S I S L L L N F
 CAGATCTGTTTCTCCCAACAGAAAAAGTCAAGTAAATGGTTTCTTGGACACGCTTAT
 R S C F S Q Q K K V T L N G F L D T L M
 GTCAGATCTCCCCCGCAGTGTCTGGTCTGGTTGCTCTTCTGCATCGACTAGCAATGT
 S D P P P Q C L V W L P L L H R L A N V
 GGAAAATGCTTCCATCCGGTGTAGTGTCTCTACTGCCACAGTGAAGATGATGGGATT
 E N V F H P V E C S Y C H S E S M M G F
 TCGTACCAGTCCCAACAGTGTCACAATACAGCTCTGTCCAGGACTGCTTCTGGAGGG
 R Y R C Q Q C H N Y Q L C Q D C F W R G
 ACATGCCGGTGGTTCTCATAGCAACCCAAATGAAAGAGTACAGTCAATGGAATC
 H A G G S H S N Q H Q M K E Y T S W K S
 ACCTGTCAAGAGCTGACTAATGCATTAAAGCAAGTCCCTGAGCTGTGCTTCCAGCGTGA
 P A K K L T N A L S K S L S C A S S R E
 ACCTTTGCACCCATGTTCCAGATCAGCCTGAGAAGCCACTCAACTTGGCTCACATCGT
 P L H P M F P D Q P E K P L N L A H I V
 TGATACTTGGCTCCAGACCTGTAACCAGATGAACGACACCCCTGTTCTCCCACTCTGT
 D T W P P R P V T S M N D T L F S H S V
 TCCCTCTCAGGAAGTCTTTTATACAGAGCTCGGACGGTCTTTTGGTGGATGGT
 P S S G S P F I T R S S D G A F G G C V
 CTAGATGGATAACATGACTTCTCTACCTAAATAATTCCTATAACTTTGAGCTGTT
 *
 TGGTTCTCCAGGGTGCATGGTACCATTAACCCAAAATATGATTATTTCCCTTTTTC
 CATTTTCAGTCATTTTGAAGTGTCTGTGAACACAGTGTGTTGTTTAAAGCTCACA
 TTTCTTCTGTCAACACAGAGATTGGCCTACGGTCTGTTTGGAGGCTGCTTCAATA
 AAGCTGTGTACACTAAAAA

deficient *mdx* muscle were analysed, the α -dystrobrevin-1 staining was lost from the sarcolemma, but was still concentrated at the NMJ (Fig. 2). These data suggest that α -dystrobrevin-1 is a dystrophin-associated protein at the sarcolemma but may also bind to utrophin at the NMJ. These data were also confirmed and extended with a second antibody, β CT-FP, that detects α -dystrobrevin -1 and -2 and β -dystrobrevin (Blake et al., 1998). This antibody strongly labels the sarcolemma and NMJ of normal muscle (Fig. 2E). In common with the antibody that only detects α -dystrobrevin-1, the labelling at the sarcolemma with β CT-FP is severely reduced but retained at the NMJ (Fig. 2G). This labelling pattern is not attributable to cross-reaction with β -

Fig. 1. α -dystrobrevin isoforms expressed in muscle. (A) Northern blot analysis of α -dystrobrevin in muscle. (Upper panel) Human multiple tissue northern blot hybridised with a probe derived from the 5' end of the human α -dystrobrevin cDNA that detects all α -dystrobrevin isoforms. The major hybridising transcripts are indicated. An asterisk denotes that α -dystrobrevin-1 and -2 are encoded by two different transcripts (Ambrose et al., 1997), only the larger of which is shown. (Lower panel) The same northern blot hybridised with a probe derived from the 3' untranslated region of α -dystrobrevin-3. Lane 1, heart; lane 2, brain; lane 3, placenta; lane 4, lung; lane 5, liver; lane 6, skeletal muscle; lane 7, kidney; lane 8, pancreas. The sizes of the molecular mass markers in kb are indicated. (B) The sequence of human and mouse α -dystrobrevin-3. The nucleotide and primary sequence of human α -dystrobrevin-3 is shown. The mouse primary sequence is shown beneath the human sequence. Only amino acid differences are shown. (C) The sequence of the 3' unique regions of human and mouse α -dystrobrevin-3 are compared. The stop codons are shown in bold typeface. The putative polyadenylation consensus sequences are underlined. (D) α -dystrobrevin isoforms expressed in muscle. Diagram showing the domain organisation of the three α -dystrobrevin isoforms expressed in mature mammalian skeletal muscle, together with β -dystrobrevin. The vr3 sequence is only expressed in muscle but is not found in α -dystrobrevin-3 (Blake et al., 1996). EF, EF-hand region; ZZ, ZZ domain (Ponting et al., 1996); vr3, variable region 3; CC, coiled-coil domain (Blake et al., 1995); Y, tyrosine kinase substrate domain.

dystrobrevin because β -dystrobrevin is not expressed in myofibres but is present in peripheral nerves often found in muscle sections (D. J. B., unpublished observation). It can therefore be concluded that levels of α -dystrobrevins-1 and -2 are reduced at the sarcolemma of the *mdx* mouse, indicating that both proteins are likely to be dystrophin-associated. These data agree with studies of α -dystrobrevin localisation in the muscles of DMD patients that were performed using antibodies that were not isoform-specific (Metzinger et al., 1997).

To demonstrate an association between α -dystrobrevin-1 and dystrophin in skeletal muscle, reciprocal immunoprecipitation experiments were performed with α -dystrobrevin-1- and dystrophin-specific antisera. Dystrophin is co-immunoprecipitated with the α 1CT-FP antisera but not with an unrelated antibody or the pre-immune sera (Fig. 3A). This association was confirmed by co-immunoprecipitating α -dystrobrevin-1 with the anti-dystrophin P6 polyclonal antisera (Fig. 3B). These results show that α -dystrobrevin-1 is a dystrophin-associated protein but may also bind to utrophin, since α -dystrobrevin-1 is retained at the NMJ in *mdx* mouse muscle.

Co-expression of α -dystrobrevin-1 and utrophin in cultured C2 myotubes

To investigate whether α -dystrobrevin is involved in synapse formation, we examined the role of α -dystrobrevin in C2 myotubes, a system frequently used by researchers studying the events of synaptogenesis in vitro. Northern and western blots showed that the α -dystrobrevin-1 is the major dystrobrevin isoform expressed in C2 cells (data not shown). The expression pattern of α -dystrobrevin-1 was determined by western blot analysis of protein extracts prepared from C2 cells at different time points during myoblast fusion. The

α 1CT-FP antiserum detects two proteins of similar relative mobility (Fig. 4, α -db-1). In proliferating myoblasts (d0), α -dystrobrevin-1 is found at low levels, consistent with our detection of α -dystrobrevin-1 mRNA in undifferentiated C2 myoblasts (data not shown). Within 1 day after switching to differentiation medium, α -dystrobrevin-1 becomes more abundant and remains expressed at similar levels as myoblast fusion proceeds. After 2 days in differentiation medium, a second protein with relative higher molecular mass is detected with the α 1CT-FP antibody. This high molecular mass isoform is probably an alternatively spliced form of α -dystrobrevin-1 containing the muscle expressed vr3 sequence (Blake et al., 1996). The β CT-FP antibody was used to determine the expression pattern of α -dystrobrevin-2 in C2 cells. This antibody detects α -dystrobrevin-1 and -2 in C2 cells; however, due to their different molecular mass, these proteins can be easily resolved on SDS-PAGE gels (Blake et al., 1998). α -dystrobrevin-2 is detected in late myotubes and appears to parallel the expression of dystrophin (Fig. 4, α -db-2).

Utrophin and dystrophin are potential binding partners for α -dystrobrevin-1 in C2 myotubes. To determine their expression pattern in C2 cells, identical western blots were developed with the utrophin- and dystrophin-specific antibodies. Utrophin is present at similar levels in proliferating myoblasts and differentiating myotubes (Fig. 4, utro). By contrast, dystrophin is not detected in myoblasts and early myotubes, but is detectable at later stages of myotube formation (Fig. 4, dys). β -dystroglycan, vimentin and desmin were analysed as internal controls for the co-ordinate gene expression during myoblast fusion (Fig. 4, β -dg, vim, des). These data show that members of the dystrophin protein family and their associated proteins are differentially expressed in C2 myotubes, and only utrophin and dystrobrevin are co-expressed during myoblast fusion and in early myotubes.

Co-localisation of α -dystrobrevin-1, utrophin and AChR in cultured C2 myotubes

Double-labelling experiments, using the anti- α -dystrobrevin-1 antiserum and rhodamine-labelled α -bungarotoxin, show that α -dystrobrevin-1 is expressed beneath the entire cell membrane but is enriched in spontaneously occurring AChR clusters (Fig. 5A,B). The clusters were between 2 and 20 μ m in size, indicating that they were mature, so-called macroclusters (Phillips et al., 1993). Similarly, β -dystroglycan staining was concentrated in AChR-rich clusters and along the cell surface (Fig. 5E). Interestingly, dystrophin did not appear to be in AChR-rich clusters but was relatively evenly distributed beneath the cell surface (Fig. 5C). In contrast, utrophin staining is concentrated in AChR-rich domains and is only weakly detectable beneath the cell surface (Fig. 5G,H). Thus, α -dystrobrevin-1 is expressed at the surface of C2 myotubes and is concentrated in to AChR-rich domains alongside utrophin, suggesting that these proteins may form a complex.

Co-immunoprecipitation of α -dystrobrevin-1 and utrophin in C2 myotubes

To show that α -dystrobrevin-1 and utrophin form a complex in C2 myotubes, co-immunoprecipitation experiments were

carried out using 500 μ g of proteins derived from differentiated day-8 C2 myotubes. As shown in Fig. 6 (db-1), utrophin was specifically co-immunoprecipitated using the anti- α -dystrobrevin-1 antiserum. Utrophin was not detected in immunoprecipitates formed with pre-immune serum or without a primary antibody (Fig. 6, pre, no Ab). α -dystrobrevin and utrophin also co-immunoprecipitate in extracts from adult mouse lung (data not shown), a tissue particularly rich in utrophin (Blake et al., 1996). Thus, in C2 myotubes α -dystrobrevin-1 and utrophin are physically associated and co-localise in AChR-rich membrane domains.

Agrin-induced clustering of α -dystrobrevin-1 in C2 myotubes

To determine whether the α -dystrobrevin isoforms were directly responsible for AChR cluster formation, C2 myoblasts were transfected with epitope-tagged expression constructs

encoding α -dystrobrevin-1, -2 and -3. In each case, the expression of recombinant dystrobrevin in C2 cells failed to promote cluster formation (data not shown, Nawrotzki, 1997). These data suggest that α -dystrobrevin does not play an early role in AChR clustering but may be recruited to nascent AChR clusters in response to nerve-derived factors.

The effect of agrin on the distribution of α -dystrobrevin-1 in C2 myotubes was analysed using two recombinant 95-kDa agrin isoforms (Gesemann et al., 1995); the clustering-proficient isoform containing four amino acids at site A and eight amino acids at site B (C95_{A4B8}), and the clustering-deficient isoform lacking these inserts (C95_{A0B0}). Day-6 myotubes were agrin-treated as described in Materials and methods, and the localisation of AChRs was determined by staining with rhodamine-labelled α -bungarotoxin. Untreated myotubes displayed, on average, three macroclusters per microscopic field (Fig. 7A), while treatment with the C95_{A4B8}

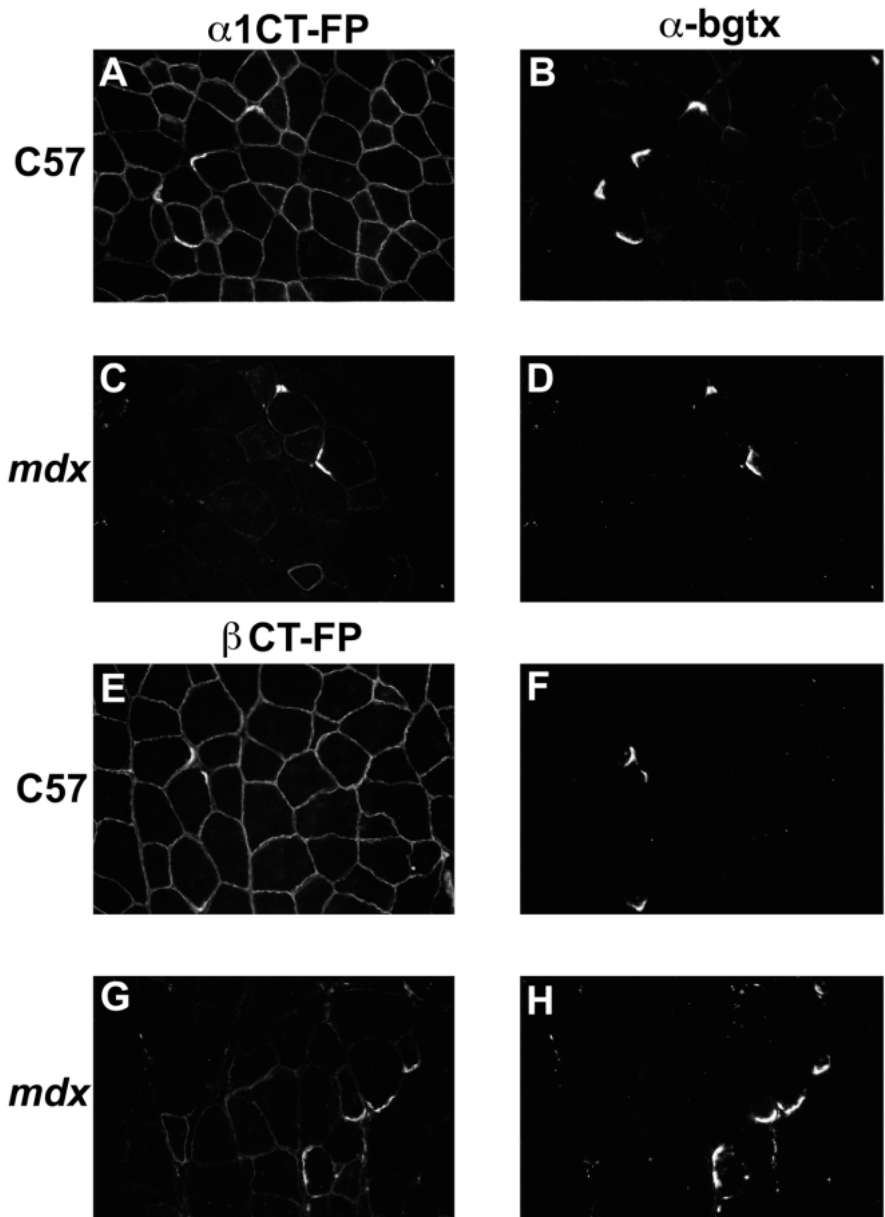

Fig. 2. Localisation of α -dystrobrevin-1 and -2 in skeletal muscle. The distribution of α -dystrobrevin-1 in normal C57 (A,B) or dystrophin-deficient *mdx* muscle (C,D) was determined with the α 1CT-FP antiserum. Endplate regions were identified by labelling with α -bungarotoxin (B and D). Note the absence of α -dystrobrevin-1 from the sarcolemma in *mdx* muscle, except in some revertant fibres. (E-H) Distribution of α -dystrobrevin-1 in normal C57 (E,F) or *mdx* muscle (G,H), determined with β CT-FP antiserum. Bar, 30 μ m.

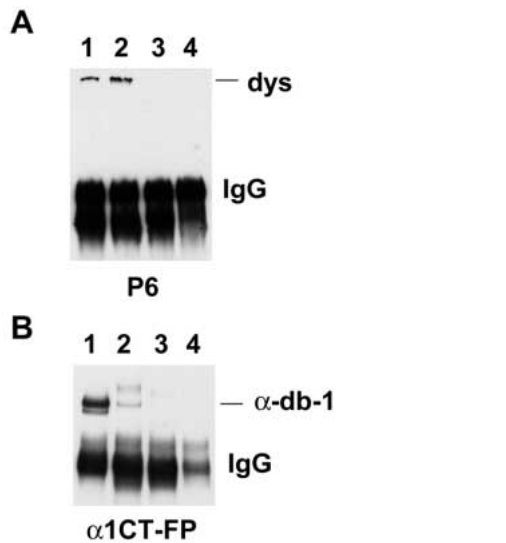

Fig. 3. Co-immunoprecipitation of α -dystrobrevin-1 and dystrophin from mouse muscle. (A) Co-immunoprecipitation of dystrophin with α -dystrobrevin-1. Solubilised mouse muscle proteins were precipitated with α 1CT-FP (lane 1), P6 (lane 2), anti-Nsk2 (lane 3) or with no primary antibody (lane 4). Co-immunoprecipitated proteins were detected with anti-dystrophin antibody P6. Dystrophin is precipitated with the anti- α -dystrobrevin-1 antibody as well as P6. (B) Co-immunoprecipitation of α -dystrobrevin-1 with dystrophin. Solubilised mouse muscle proteins were precipitated with α 1CT-FP (lane 1), P6 (lane 2), anti-Nsk2 (lane 3) or with no primary antibody (lane 4). Co-immunoprecipitated proteins were detected with anti- α -dystrobrevin-1 antibody α 1CT-FP. α -dystrobrevin-1 is precipitated with the anti-dystrophin antibody P6 (lane 2) as well as with α 1CT-FP. The IgG heavy chain is detected by the HRP-conjugated anti-rabbit antibody as indicated.

isoform caused a nearly tenfold increase in the number of AChR macroclusters (Fig. 7A). The C95_{A0B0} isoform slightly increased the number of clusters (Fig. 7A). Thus, C95_{A4B8} agrin induced the formation of AChR macroclusters and is therefore suitable for studying the effect of agrin on the distribution of α -dystrobrevin-1 in C2 myotubes.

Myotubes were treated with or without agrin, and the average number of α -dystrobrevin-1 clusters per microscopic field was determined using the anti-dystrobrevin-1 antiserum. Untreated myotubes expressed α -dystrobrevin-1 evenly distributed at the cell membrane and in macroclusters, as shown in Fig. 5C,D. Treatment with C95_{A4B8} agrin had a dramatic effect on the distribution of α -dystrobrevin-1, causing a tenfold increase in the number of macroclusters (Fig. 7A). Concomitantly, agrin stimulation reduced the surface expression of α -dystrobrevin-1 (data not shown). C95_{A0B0} agrin did not increase the number of α -dystrobrevin-1 clusters (Fig. 7A). Double-labelling experiments using the anti-dystrobrevin-1 antiserum and rhodamine-labelled α -bungarotoxin show that α -dystrobrevin-1 and AChR clusters precisely overlap in agrin-treated C2 myotubes (Fig. 7B). Thus, agrin causes the clustering of AChRs and α -dystrobrevin-1 into similar sub-membranous domains in C2 muscle cells. Thus, in C2 myotubes, α -dystrobrevin-1 is re-distributed into AChR-rich membrane domains where it may be involved in the stabilisation of AChR aggregates.

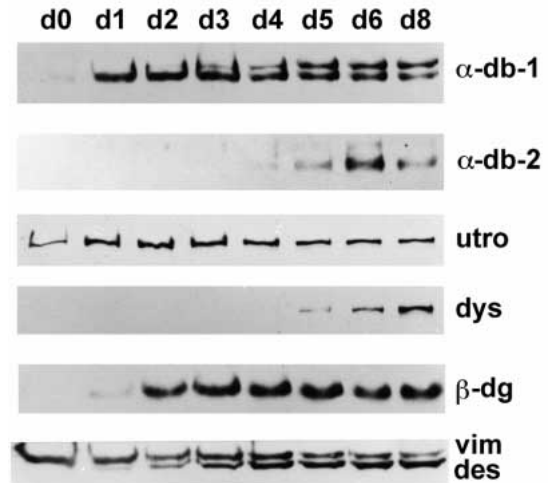

Fig. 4. Differentially regulated expression of α -dystrobrevin-1 in C2 myotubes. Total cell extracts were prepared from C2 muscle cells at different time points (in days, d) during myoblast fusion in culture. 30 μ g of protein were separated on 8% SDS-polyacrylamide gels, blotted and probed with antibodies against α -dystrobrevin-1 (α -db-1), α -dystrobrevin-2 (α -db-2), utrophin (utro), dystrophin (dys), β -dystroglycan (β -dg) and vimentin/desmin (vim, des). Note the expression of α -dystrobrevin-1, utrophin and vimentin in proliferating myoblasts (d0) and during myotube formation. In contrast, α -dystrobrevin-2 and dystrophin are only expressed in late myotubes (d5-d8).

Pervanadate, but not agrin, increases tyrosine phosphorylation of α -dystrobrevin-1

Since agrin clusters α -dystrobrevin-1, we analysed whether agrin also stimulated its tyrosine phosphorylation. Initially, we treated C2 myotubes with sodium pervanadate, a tyrosine phosphatase inhibitor (Meier et al., 1995). α -dystrobrevin-1 was immunoprecipitated with the anti-dystrobrevin-1 antiserum and analysed on western blots using the anti-phosphotyrosine mAb 4G10-HRP. As shown in Fig. 8 (left lane), both α -dystrobrevin-1 isoforms, expressed in differentiated myotubes, were phosphorylated by pervanadate. Consistent with this, the presumed non-muscle isoform contained more phosphotyrosine than the presumed vr3-containing isoform. Control experiments show that MuSK is also phosphorylated in pervanadate-treated C2 myotubes (Fig. 8, middle lane).

To determine the effect of agrin on the phosphorylation of α -dystrobrevin-1, day-6 myotubes were incubated without agrin (0 minutes) or with 10 nM C95_{A4B8} agrin for 6 minutes, 30 minutes or 4 hours. This regime is suitable for detecting tyrosine phosphorylation of MuSK (Glass et al., 1996) and the AChR β -subunit (Wallace et al., 1991; Ferns et al., 1996). α -dystrobrevin-1 was immunoprecipitated and analysed as described above. As shown in Fig. 9A, we did not detect tyrosine phosphorylation in α -dystrobrevin-1 precipitates during 4 hours of agrin incubation (the 55-kDa band present in all lanes of Fig. 9A-C corresponds to phosphorylated IgG heavy chain). Re-probing of the blot in Fig. 9A with the anti-dystrobrevin-1 antiserum shows that α -dystrobrevin-1 was precipitated in the experiment, but not in the pre-immune control (Fig. 9B). A control experiment was carried out using the anti-MuSK antiserum (Meier et al., 1997). As shown in

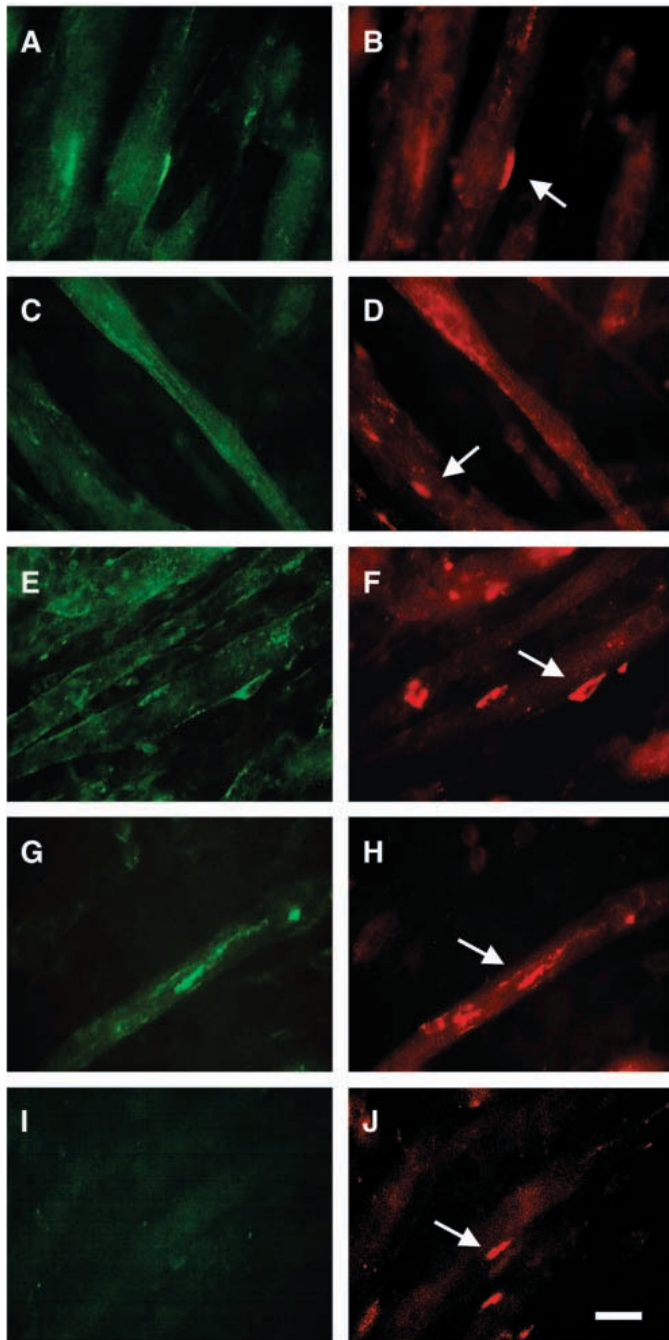

Fig. 5. Localisation of α -dystrobrevin-1 and associated proteins in C2 myotubes. C2 myotubes were fixed, permeabilised and double-labelled with rhodamine-labelled α -bungarotoxin (B,D,F,H,J) and antibodies against α -dystrobrevin-1 (A), dystrophin (C), β -dystroglycan (E), utrophin (G) or without a primary antibody (I). All proteins are localised at the cell membrane and in AChR-rich domains with the exception of dystrophin, which was not found to be clustered (B,D,F,H,J, arrows). The membrane labelling of utrophin (G) is fainter than that of the other proteins. Bar, 16 μ m.

Fig. 7C, 6 minutes incubation with C95_{A4B8} agrin is sufficient to induce tyrosine phosphorylation of MuSK; maximum levels are found after 30 minutes, and reduced levels after 4 hours, essentially as described (Glass et al., 1996). Thus, although agrin recruits α -dystrobrevin-1 into AChR-rich

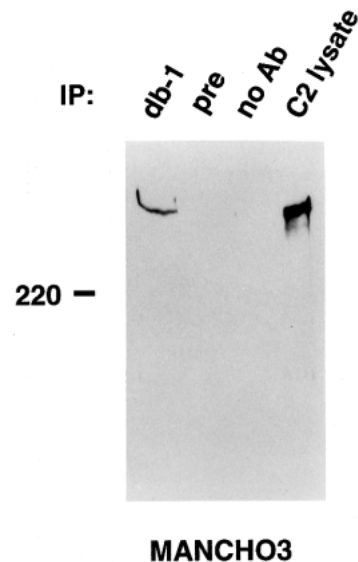

Fig. 6. Co-immunoprecipitation of α -dystrobrevin-1 and utrophin in C2 myotubes. 500 μ g of RIPA-buffer-solubilized protein from day-8 C2 myotubes was precipitated with the anti-dystrobrevin-1 antiserum (db-1), pre-immune serum (pre) or without antibodies (no Ab). Immune complexes were recovered with protein A-Sepharose, electrophoresed, blotted and probed with the utrophin-specific mAb MANCHO3. Utrophin is specifically co-immunoprecipitated with α -dystrobrevin-1 (db-1). A loading control (C2 lysate) indicates the size of endogenous utrophin in C2 myotubes. The size of myosin heavy chain (in kDa) is indicated.

domains in C2 myotubes, it does not induce its tyrosine phosphorylation.

DISCUSSION

In this paper we describe the analysis of α -dystrobrevin in muscle. Adult skeletal muscle expresses three α -dystrobrevin isoforms, α -dystrobrevin-1, -2 and -3, of which α -dystrobrevins-1 and -2 contain the muscle expressed vr3 sequence (Blake et al., 1996). α -dystrobrevin-3 is a muscle-expressed, truncated dystrobrevin isoform that has a short unique C terminus. Unlike α -dystrobrevins-1 and -2, α -dystrobrevin-3 is encoded by a single 1.7 kb transcript. The α -dystrobrevin-3 transcript encodes a 42 kDa protein that is expressed in skeletal and cardiac muscle. The expression of this isoform in muscle only contrasts with the widespread expression of α -dystrobrevins-1 and -2 in different tissues, suggesting a specific role for α -dystrobrevin-3 in muscle. Interestingly, the α -dystrobrevin-3 mRNA is the most abundant transcript from the α -dystrobrevin gene expressed in adult tissue (Fig. 1A). Since α -dystrobrevin-3 lacks the syntrophin-binding site, α -dystrobrevin-3 is unlikely to be a dystrophin-associated protein.

Previous studies have localised dystrobrevin-reactive proteins to regions in skeletal muscle, similar to those described in this report (Carr et al., 1989; Blake et al., 1996; Peters et al., 1997a). However, the antibodies used in these experiments were not isoform-specific but also detected other dystrobrevin-reactive proteins. For example, the monoclonal

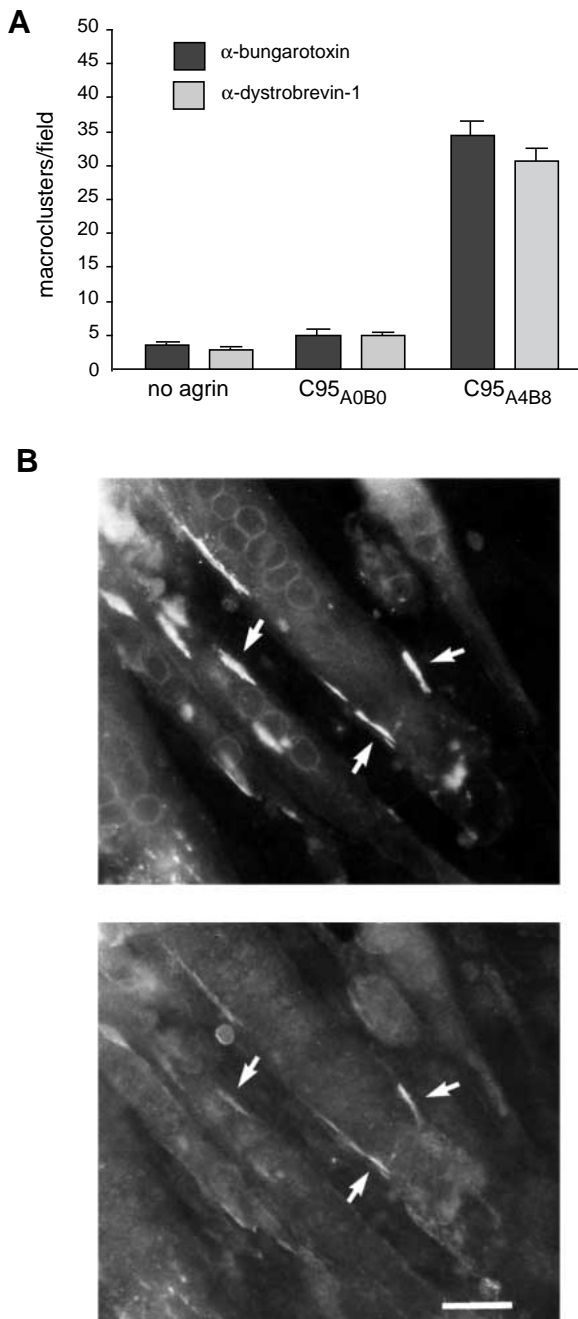

Fig. 7. Agrin-induced clustering of α -dystrobrevin-1 in C2 myotubes. Day-6 C2 myotubes were treated for 16 hours with 1 nM C95_{A4B8} agrin, 1 nM C95_{A0B0} agrin, or without agrin. (A) Parallel cultures were fixed and permeabilised, and stained with the α 1CT-FP antiserum (dystrobrevin) or rhodamine-labelled α -bungarotoxin. In each experiment, α -dystrobrevin-1 and AChRs were localised in macroclusters, ranging in length from 2 to 20 μ m (see B). The number of macroclusters were counted in 20 independent microscopic fields that contained three or more multi-nucleated myotubes. The mean number of macroclusters (\pm s.e.m.) are shown. Only treatment with the clustering-proficient C95_{A4B8} agrin induces a tenfold increase of α -dystrobrevin-1 and AChR macroclusters. (B) C2 myotubes were treated with clustering-proficient agrin as above and double-stained with rhodamine-labelled α -bungarotoxin (upper panel) and α 1CT-FP (lower panel). Agrin-induced clusters containing α -dystrobrevin-1 and AChRs overlap precisely (arrows). Bar, 30 μ m.

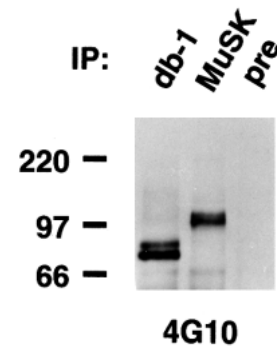

Fig. 8. Peroxivanadate induces tyrosine phosphorylation of α -dystrobrevin-1 and MuSK in C2 myotubes. C2 myotubes were treated for 15 minutes with peroxivanadate. Cell lysates were immunoprecipitated with the anti-dystrobrevin-1 antiserum (db-1), the anti-MuSK antiserum (MuSK), or pre-immune serum (pre). Western blots were developed with the anti-phosphotyrosine mAb 4G10. Both α -dystrobrevin-1 and MuSK are tyrosine-phosphorylated by peroxivanadate. Note that the lower molecular mass α -dystrobrevin-1 isoform contains more phosphotyrosine than the higher molecular mass form. Molecular mass markers (in kDa) are indicated on the left.

antibody 13H1 was raised against the *Torpedo* 87K protein (Carr et al., 1989) and detects multiple 87K/dystrobrevin-reactive bands in different rat tissues (Kramarcy et al., 1994). Likewise, the polyclonal antibodies 308 and 433 detect α -dystrobrevin-1, -2 and β -dystrobrevin in various mouse tissues (Blake et al., 1996, 1998; Peters et al., 1997a,b). Because α -dystrobrevin-1 is the orthologue of the *Torpedo* 87K protein and was initially co-purified with the AChRs from electric organ (Carr et al., 1989; Wagner et al., 1993), we have used specific antibodies and a cell culture system to unravel the complex interactions between α -dystrobrevin-1 and its binding partners in muscle.

Using C2 cells that differentiate from myoblasts to myotubes we have shown that α -dystrobrevin-1 is located beneath the myotube surface and is enriched in spontaneously formed AChR-containing clusters that label with α -bungarotoxin. Following agrin treatment, α -dystrobrevin-1 is dramatically redistributed into AChR clusters accompanied by an approximately tenfold increase in the number of receptor clusters. These data show the intimate relationship between α -dystrobrevin-1 and the AChR-containing clusters.

Relatively few proteins have been reported to be redistributed following agrin treatment in cultured muscle cells or in ectopically formed synapses (see Bowe and Fallon, 1995; Meier et al., 1997). All of the proteins clustered into AChR-rich domains by agrin treatment are key components of the synapse. These include the erbB family of heregulin receptors (Meier et al., 1997), the voltage-gated sodium channels (Sharp and Caldwell, 1996) and the dystrophin-related protein utrophin (Phillips et al., 1993). Our findings support the hypothesis that α -dystrobrevin-1 is a structural protein at the synapse. However, we have also shown that α -dystrobrevin-1 is a utrophin-associated protein in the C2 cells. Thus, it is possible that α -dystrobrevin-1 becomes localised into AChR-rich domains via a direct interaction with utrophin. Alternatively, α -dystrobrevin-1 could recruit utrophin into

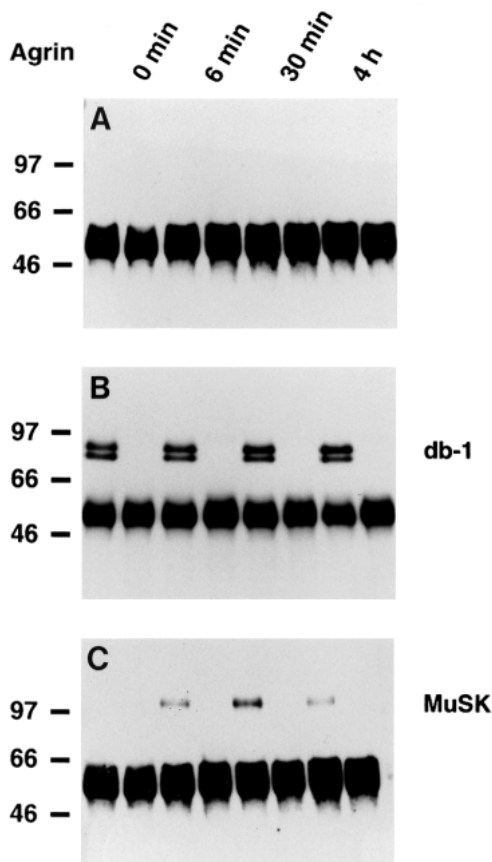

Fig. 9. Agrin does not induce tyrosine phosphorylation of α -dystrobrevin-1. C2 myotubes were treated with 10 nM C95_{A4B8} agrin for the times indicated on the top of the figure. At each time point, cell lysates were precipitated with the anti-dystrobrevin-1 antiserum (A,B) or the anti-MuSK antiserum (C). In every second lane of A-C, pre-immune serum was used. Precipitates were electrophoresed, blotted and probed with the anti-phosphotyrosine antibody (A,C) or the anti-dystrobrevin-1 antiserum (B). The control experiment (C) shows that agrin phosphorylates MuSK after 6 minutes, maximum levels are detected after 30 minutes, and phosphorylation declines after 4 hours. In contrast, agrin does not phosphorylate α -dystrobrevin-1 during these incubation times (A). Reprobing of the blot in A shows that α -dystrobrevin-1 was precipitated in the experiment (B). Note that immunoglobulin heavy chain contains high levels of phosphotyrosine. Molecular mass markers (in kDa) are indicated on the left.

AChR-containing clusters possibly through an interaction with an as yet unidentified kinase or adapter protein.

We have shown that agrin induces the clustering of α -dystrobrevin-1 into AChR-rich domains in C2 myotubes, and that this clustering is accompanied with a reduction in the surface staining of α -dystrobrevin-1. Since agrin acts via MuSK and the promotion of tyrosine phosphorylation (Glass et al., 1996), we tested the hypothesis that α -dystrobrevin-1 was a substrate in the same signalling pathway. α -dystrobrevin-1 is not phosphorylated in response to agrin stimulation, although it can be phosphorylated by treating cells with pervanadate. Control experiments showed that agrin induces the phosphorylation of MuSK, ruling out the possibility that the clustering-proficient agrin isoform used in our experiments

had lost their activity. It is possible that agrin-induced phosphorylation of α -dystrobrevin-1 occurs later than 4 hours of treatment. However, agrin-induced tyrosine phosphorylation of postsynaptic proteins is a rapid process in culture, occurring within minutes and preceding AChR clustering by several hours (Wallace et al., 1991; Meier et al., 1995; Glass et al., 1996). Thus, although agrin re-distributes α -dystrobrevin-1 into AChR-rich membrane domains, it does not induce its tyrosine phosphorylation. It is now apparent that agrin only causes the autophosphorylation of MuSK. The β subunit of the AChR is thought to be phosphorylated by a src-related kinase that may be activated by MuSK (Fuhrer and Hall, 1996; Altiok et al., 1997).

Although agrin treatment failed to phosphorylate α -dystrobrevin-1, it is known that multiple signalling pathways are required to orchestrate synaptogenesis. These pathways include c-src-mediated tyrosine phosphorylation and the MAP/ras kinase cascade (Fuhrer and Hall, 1996; Altiok et al., 1997). It remains unclear as to which signalling events are blocked by inhibitors of tyrosine phosphorylation in muscle. It is possible that α -dystrobrevin-1 is phosphorylated by one of the src-family of tyrosine kinases. The *Torpedo* of α -dystrobrevin-1 crossreacts with an antibody raised against the autophosphorylation site of c-src (Wagner et al., 1993). This antibody also crossreacts with other src-related kinases such as yes and fyn (Fuhrer and Hall, 1996).

In addition to utrophin, α -dystrobrevin-1 is also associated with dystrophin in muscle and C2 cells. We have shown that α -dystrobrevin-1 behaves like a typical dystrophin-associated protein. For example, the levels of α -dystrobrevin-1 are severely reduced at the sarcolemma of the *mdx* mouse but are retained at the NMJ, presumably through an interaction between α -dystrobrevin-1 and utrophin (Fig. 2). In addition to dystrophin and utrophin, α -dystrobrevin-1 and -2 also bind directly to the syntrophin family of proteins (Blake et al., 1996; Peters et al., 1997a). Whilst β 2-syntrophin appears to be preferentially associated with utrophin, no such selectivity can be assigned to α -dystrobrevin-1 (Peters et al., 1997a).

The data presented in this paper demonstrate a complex expression pattern of α -dystrobrevin in muscle and suggest that the different α -dystrobrevin isoforms may be involved in the organisation of specific protein complexes at the sarcolemma and postsynaptic membrane of the NMJ. Our evidence shows that α -dystrobrevin-1 is not involved in the early stages of AChR cluster formation, but rather acts, together with utrophin, in the agrin-induced maturation of the postsynaptic cytoskeleton. A preliminary description of α -dystrobrevin-deficient mice that have postsynaptic abnormalities similar to those described for the utrophin-deficient mouse, supports the data presented here (Sanes, 1997).

The authors thank Dr Thomas Meier for advice with the phosphotyrosine experiment; Drs Jon Tinsley, Jill Rafael, Sarah Newey, Andrew Stoker and Lynne Cox for helpful discussions; Drs Peter Strong, Louise Anderson and Dave Simmons for antibodies. This work was supported by grants from the Wellcome Trust, Medical Research Council and the Association Française contre les Myopathies (AFM). D. J. B. holds a Wellcome Trust Career Development Fellowship. N. Y. L. is a Rhodes Scholar. The work of M. A. R. is supported by the Swiss National Science Foundation, the Swiss Foundation for Research on Muscle Diseases, the

Rentenanstalt/Swiss Life and the Sandoz-Stiftung. The initial part of this work was supported by the DFG (R. N.).

EMBL Accession Number: AJ009668, AJ009669.

REFERENCES

- Altiok, N., Altiok, X. and Changeux, J. P. (1997). Heregulin-stimulated acetylcholine receptor gene expression in muscle: Requirement for MAP kinase and evidence for a parallel inhibitory pathway independent of electrical activity. *EMBO J.* **14**, 717-24.
- Ambrose, H. J., Blake, D. J., Nawrotzki, R. A. and Davies, K. E. (1997). Genomic organization of the mouse dystrobrevin gene: comparative analysis with the dystrophin gene. *Genomics* **39**, 133-69.
- Blake, D. J., Tinsley, J. M., Davies, K. E., Knight, A. E., Winder, S. J. and Kendrick-Jones, J. (1995). Coiled-coil regions in the carboxy-terminal domains of dystrophin and related proteins: potentials for protein-protein interactions. *Trends Biochem. Sci.* **20**, 133-5.
- Blake, D. J., Nawrotzki, R., Peters, M. F., Froehner, S. C. and Davies, K. E. (1996). Isoform diversity of dystrobrevin, the murine 87-kDa postsynaptic protein. *J. Biol. Chem.* **271**, 7802-10.
- Blake, D. J., Nawrotzki, R., Loh, N. Y., Górecki, D. C. and Davies, K. E. (1998). β -dystrobrevin, a member of the dystrophin-related protein family. *Proc. Nat. Acad. Sci. USA* **95**, 241-6.
- Bowe, M. A. and Fallon, J. R. (1995). The role of agrin in synapse formation. *Annu. Rev. Neurosci.* **18**, 443-62.
- Butler, M. H., Douville, K., Murnane, A. A., Kramarcy, N. R., Cohen, J. B., Sealock, R. and Froehner, S. C. (1992). Association of the M_r 58,000 postsynaptic protein of electric tissue with Torpedo dystrophin and the M_r 87,000 postsynaptic protein. *J. Biol. Chem.* **267**, 6213-8.
- Carr, C., Fischbach, G. D. and Cohen, J. B. (1989). A novel 87,000- M_r protein associated with acetylcholine receptors in Torpedo electric organ and vertebrate skeletal muscle. *J. Cell Biol.* **109**, 1753-64.
- Deconinck, A. E., Potter, A. C., Tinsley, J. M., Wood, S. J., Vater, R., Young, C., Metzinger, L., Vincent, A., Slater, C. R. and Davies, K. E. (1997). Postsynaptic abnormalities at the neuromuscular junctions of utrophin-deficient mice. *J. Cell Biol.* **136**, 883-94.
- Duclert, A. and Changeux, J. P. (1995). Acetylcholine receptor gene expression at the developing neuromuscular junction. *Physiol. Rev.* **75**, 339-68.
- Dwyer, T. M. and Froehner, S. C. (1995). Direct binding of Torpedo syntrophin to dystrophin and the 87 kDa dystrophin homologue. *FEBS Lett.* **375**, 91-4.
- Ferns, M., Deiner, M. and Hall, Z. (1996). Agrin-induced acetylcholine receptor clustering in mammalian muscle requires tyrosine phosphorylation. *J. Cell Biol.* **132**, 937-44.
- Fuhrer, C. and Hall, Z. W. (1996). Functional interactions of Src family kinases with the acetylcholine receptor in C2 myotubes. *J. Biol. Chem.* **271**, 32474-81.
- Gesemann, M., Denzer, A. J. and Ruegg, M. A. (1995). Acetylcholine receptor-aggregating activity of agrin isoforms and mapping of the active site. *J. Cell Biol.* **128**, 625-36.
- Gesemann, M., Brancaccio, A., Schumacher, B. and Ruegg, M. A. (1998). Agrin is a high-affinity binding protein of dystroglycan in non-muscle tissue. *J. Biol. Chem.* **273**, 600-5.
- Glass, D. J., Bowen, D. C., Stitt, T. N., Radziejewski, C., Bruno, J., Ryan, T. E., Gies, D. R., Shah, S., Mattsson, K., Burden, S. J., DiStefano, P. S., Valenzuela, D. M., DeChiara, T. M. and Yancopoulos, G. D. (1996). Agrin acts via a MuSK receptor complex. *Cell* **85**, 513-23.
- Grady, R. M., Merlie, J. P. and Sanes, J. R. (1997). Subtle neuromuscular defects in utrophin-deficient mice. *J. Cell Biol.* **136**, 871-82.
- Hall, Z. W. and Sanes, J. R. (1993). Synaptic structure and development: the neuromuscular junction. *Cell* **72** Supplement, 99-121.
- Kramarcy, N. R., Vidal, A., Froehner, S. C. and Sealock, R. (1994). Association of utrophin and multiple dystrophin short forms with the mammalian M_r 58,000 dystrophin-associated protein (syntrophin). *J. Biol. Chem.* **269**, 2870-6.
- Lyons, P. R. and Slater, C. R. (1991). Structure and function of the neuromuscular junction in young adult mdx mice. *J. Neurocytol.* **20**, 969-81.
- Matsumura, K., Ervasti, J. M., Ohlendieck, K., Kahl, S. D. and Campbell, K. P. (1992). Association of dystrophin-related protein with dystrophin-associated proteins in mdx mouse muscle. *Nature* **360**, 588-91.
- Meier, T., Perez, G. M. and Wallace, B. G. (1995). Immobilization of nicotinic acetylcholine receptors in mouse C2 myotubes by agrin-induced protein tyrosine phosphorylation. *J. Cell Biol.* **131**, 441-51.
- Meier T., Gesemann, M., Cavalli, V., Ruegg, M. A. and Wallace, B. G. (1996). AChR phosphorylation and aggregation induced by an agrin fragment that lacks the binding site for α -dystroglycan. *EMBO J.* **15**, 2625-31.
- Meier, T., Hauser, D. M., Chiquet, M., Landmann, L., Ruegg, M. A. and Brenner, H. R. (1997). Neural agrin induces ectopic postsynaptic specializations in innervated muscle fibers. *J. Neurosci.* **17**, 6534-6544.
- Metzinger, L., Blake, D. J., Squier, M. V., Anderson, L. V., Deconinck, A. E., Nawrotzki, R., Hilton Jones, D. and Davies, K. E. (1997). Dystrobrevin deficiency at the sarcolemma of patients with muscular dystrophy. *Hum. Mol. Genet.* **6**, 1185-91.
- Nawrotzki, R. (1997). Molecular analysis of dystrobrevin. D. Phil thesis, University of Oxford.
- Nguyen, T. M., Ellis, J. M., Love, D. R., Davies, K. E., Gatter, K. C., Dickson, G. and Morris, G. E. (1991). Localization of the DMDL gene-encoded dystrophin-related protein using a panel of nineteen monoclonal antibodies: presence at neuromuscular junctions, in the sarcolemma of dystrophic skeletal muscle, in vascular and other smooth muscles, and in proliferating brain cell lines. *J. Cell Biol.* **115**, 1695-700.
- Ohlendieck, K., Ervasti, J. M., Matsumura, K., Kahl, S. D., Leveille, C. J. and Campbell, K. P. (1991). Dystrophin-related protein is localized to neuromuscular junctions of adult skeletal muscle. *Neuron* **7**, 499-508.
- Peters, M. F., Adams, M. E. and Froehner, S. C. (1997a). Differential association of syntrophin pairs with the dystrophin complex. *J. Cell Biol.* **138**, 81-93.
- Peters, M. F., O'Brien, K. F., Sadoulet-Puccio, H. M., Kunkel, L. M., Adams, M. E. and Froehner, S. C. (1997b). β -dystrobrevin, a new member of the dystrophin family. *J. Biol. Chem.* **272**, 31561-69.
- Phillips, W. D., Noakes, P. G., Roberds, S. L., Campbell, K. P. and Merlie, J. P. (1993). Clustering and immobilization of acetylcholine receptors by the 43-kD protein: a possible role for dystrophin-related protein. *J. Cell Biol.* **123**, 729-40.
- Ponting, C. P., Blake, D. J., Davies, K. E., Kendrick-Jones, J. and Winder, S. J. (1996). ZZ and TAZ: New putative zinc fingers in dystrophin and other proteins. *Trends Biochem. Sci.* **21**, 11-3.
- Pruss, R. M., Mirsky, R., Raff, M. C., Thorpe, R., Dowding, A. J. and Anderton, B. H. (1981). All classes of intermediate filaments share a common antigenic determinant defined by a monoclonal antibody. *Cell* **27**, 419-28.
- Roberts, R. G. and Bobrow, M. (1998). Dystrophin in vertebrates and invertebrates. *Hum. Mol. Genet.* **7**, 589-95.
- Ruegg, M. A. and Bixby, J. L. (1998). Agrin orchestrates synaptic differentiation at the vertebrate neuromuscular junction. *Trends Neurosci.* **21**, 22-7.
- Sadoulet-Puccio, H. M., Khurana, T. S., Cohen, J. B. and Kunkel, L. M. (1996). Cloning and characterization of the human homologue of a dystrophin related phosphoprotein found at the Torpedo electric organ post-synaptic membrane. *Hum. Mol. Genet.* **5**, 489-96.
- Sanes, J. R. (1997). Genetic analysis of postsynaptic differentiation at the vertebrate neuromuscular junction. *Curr. Opin. Neurobiol.* **7**, 93-100.
- Sharp, A. A. and Caldwell, J. H. (1996). Aggregation of sodium channels induced by a postnatally upregulated isoform of agrin. *J. Neurosci.* **16**, 6775-83.
- Sherratt, T. G., Vulliamy, T. and Strong, P. N. (1992). Evolutionary conservation of the dystrophin central rod domain. *Biochem. J.* **287**, 755-9.
- Wagner, K. R., Cohen, J. B. and Haganir, R. L. (1993). The 87K postsynaptic membrane protein from Torpedo is a protein-tyrosine kinase substrate homologous to dystrophin. *Neuron* **10**, 511-22.
- Wagner, K. R. and Haganir, R. L. (1994). Tyrosine and serine phosphorylation of dystrophin and the 58-kDa protein in the postsynaptic membrane of Torpedo electric organ. *J. Neurochem.* **62**, 1947-52.
- Wallace, B. G., Qu, Z. and Haganir, R. L. (1991). Agrin induces phosphorylation of the nicotinic acetylcholine receptor. *Neuron* **6**, 869-78.
- Wallace, B. G. (1995). Regulation of the interaction of nicotinic acetylcholine receptors with the cytoskeleton by agrin-activated protein tyrosine kinase. *J. Cell Biol.* **128**, 1121-29.
- Xu, R. and Salpeter, M. M. (1997). Acetylcholine receptors in innervated muscle of dystrophin mdx mice degrade as after denervation. *J. Neurosci.* **17**, 8194-200.
- Yaffe, D. and Saxel, O. (1977). Serial passaging and differentiation of myogenic cells isolated from dystrophic mouse muscle. *Nature* **270**, 725-7.