

GEORGIA INSTITUTE OF TECHNOLOGY
OFFICE OF CONTRACT ADMINISTRATION
SPONSORED PROJECT INITIATION

adg

Date: October 6, 1976

Project Title: "A Kinetics Investigation of Several Reactions Involving Bromine Compounds as Related to Flame Initiation and Propagation."

Project No: B-477

Project Director: ~~Dr. D. D. Davis~~ *Green*

Sponsor: U. S. Department of Commerce, National Bureau of Standards, Washington, D. C.

Agreement Period: From September 1, 1976 Until April 30 - 1977
~~August 31, 1977~~

Type Agreement: GT-9020

Amount: \$27,961 (plus \$2,668 GIT cost-sharing contribution)

Reports Required: Quarterly Progress Reports, Final Technical Report

Sponsor Contact Person (s):

Technical Matters

Contractual Matters
(thru OCA)

Dr. Richard Gann
U. S. Department of Commerce
National Bureau of Standards
Washington, D.C. 20234
(301) 921-3771

Mr. G. A. Cauley
U.S. Department of Commerce
National Bureau of Standards
Washington, D. C. 20233

Defense Priority Rating: None

Assigned to: Applied Sciences (School/Laboratory)

COPIES TO:

Project Director
Division Chief (EES)
School/Laboratory Director
Dean/Director-EES
Accounting Office
Procurement Office
Security Coordinator (OCA)
Reports Coordinator (OCA)

Library, Technical Reports Section
Office of Computing Services
Director, Physical Plant
EES Information Office
Project File (OCA)
Project Code (GTRI)
Other _____

GEORGIA INSTITUTE OF TECHNOLOGY
OFFICE OF CONTRACT ADMINISTRATION
SPONSORED PROJECT TERMINATION

Date: 10/24/80

Project Title: A Kinetics Investigation of Several Reactions Involving Bromine Compounds as Related to Flame Initiation and Propagation

Project No: B-477

Project Director: Dr. A.R. Ravishankara

Sponsor: U.S. Dept. of Commerce; National Bureau of Standards

Effective Termination Date: 4/30/78

Clearance of Accounting Charges: 5/31/78 (for reporting)

Grant/Contract Closeout Actions Remaining:

- Final Invoice and Closing Documents
- Final Fiscal Report
- Final Report of Inventions
- Govt. Property Inventory & Related Certificate
- Classified Material Certificate
- Other _____

Assigned to: EML/SS (~~School~~ Laboratory)

COPIES TO:

Project Director
Division Chief (EES)
School/Laboratory Director
Dean/Director-EES
Accounting Office
Procurement Office
Security Coordinator (OCA)
Reports Coordinator (OCA)

Library, Technical Reports Section
EES Information Office
Project File (OCA)
Project Code (GTRI)
Other Project Code (OCA)

DISCLAIMER:

**This document has been proofed and
its original formatting has been retained.**

B-477



ATMOSPHERIC SCIENCES DIV., APPLIED SCIENCES LABORATORY
ENGINEERING EXPERIMENT STATION
GEORGIA INSTITUTE OF TECHNOLOGY • ATLANTA, GEORGIA 30332

Jan 24, 1977

Dr. Richard Gann
U.S. Department of Commerce,
National Bureau of Standards,
Washington, D.C., 20234

Dear Dr. Gann:

Enclosed you will find our first quarter progress report for the Grant No. GT-9020. I am terribly sorry for the delay and inconvenience it has caused you.

Thanking you,

Sincerely,

Dr. A.R. Ravishankara
Research Scientist

FIRST QUARTER PROGRESS REPORT
NATIONAL BUREAU OF STANDARDS GRANT No. GT-9020

Early in the first quarter of the grant period, our laboratory moved from the University of Maryland in College park, Maryland to Georgia Institute of Technology in Atlanta. This relocation which included complete disassembly, packing, moving, and re-assembly of all laboratory equipment has greatly impeded the accomplishment of our proposed goals. Because we had to start building a laboratory in a space which had previously been occupied by offices, an extensive amount of time was spent knocking down walls, installing routine laboratory fixtures, (e.g., electrical outlets, gas and water lines), acquiring work benches and laboratory supplies.. The many weeks spent on these tasks were essential even though no visible progress toward acquiring data was made. Presently, these chores are completed, the gas handling system is operational, and the rest of the resonance fluorescence system is being re-assembled.

Because we foresaw these necessary delays in having a fully operational laboratory, we used the time to design an improved stainless steel reaction cell. In this second generation high temperature cell, all five windows are demountable. This provision which greatly ^a facilitates the routine cleaning of both the reaction cell and the windows, has been achieved by using mating conflat flanges on the reaction cell as well as on the window assemblies. A sketch of the the window assembly is given in Figure 1. As shown in this drawing, all the windows are cooled using copper cooling jackets. This feature adds a much desired dimension to our system.

We can now use the window material of our choice, including the temperature-restricted alkaline and alkaline earth halide crystals. In designing this cell a great deal of attention has been given to minimizing window heating via conduction by the cell walls and diluent gas. Metal-foil radiation shields will be installed to minimize the radiative heating of the optical crystals. These features have been included without sacrificing light baffling requirements needed to minimize scattered light.

This reaction cell and its accompanying vacuum housing are, of necessity, bigger than our previous kinetics system. The new reaction cell, the vacuum chamber, and the accompanying pieces are being fabricated in the Georgia Tech machine shop. The completion date should be March 15, 1977.

. During the second quarter of the grant period we plan to complete the installation and check the operating parameters of both the high temperature resonance fluorescence system and the new reaction cell. In addition, we plan to complete the interfacing of the new reaction system enabling time-resolved OH radical concentrations to be measured using the technique of laser induced fluorescence. The latter system will provide us with the necessary sensitivity to reach temperatures of ~ 1100 K.

Sa Tech Project # 0

SECOND QUARTER PROGRESS REPORT

NATIONAL BUREAU OF STANDARDS GRANT NO. GT-9020

In our previous progress report, we described the design of a second generation stainless steel reaction cell capable of reaching temperatures in the vicinity of 1200 K. At the present time, the fabrication of this reaction cell, its vacuum housing, and all associated components are near completion and we have initiated the testing of the new system. Figures 1, 2, and 3 display the reaction cell, inlet port and window assemblies, and the vacuum housing, respectively. This new cell, which is considerably larger than our previous stainless steel cell, can be used for the study of reactions involving Cl, O and Br atoms and OH radicals. The reactions of chlorine and oxygen atoms would be studied by replacing our existing sapphire window assemblies with MgF₂ window assemblies.

We expect that this reaction cell will yield very significant improvements in signal/noise over our previous stainless steel cell. (It should be noted that our first generation cell possessed ~ 3 times better signal/noise than conventional cells.) This further improvement has been achieved through extensive use of radiation collimation. Both the reaction cell inlet port shown in Figure 2 and the large vacuum housing shown in Figure 3 act to shape the resonance radiation and the photo-flash into well-collimated photon beams. In the case of hydroxyl radical reaction rate studies, in

which laser-induced fluorescence detection is to be used, the obtainable signal/noise should be orders of magnitude higher than those characteristic of conventional OH kinetics experiments. In addition to overseeing the fabrication of the components described above, we have been working on the logistic details of utilizing laser-induced fluorescence in a kinetics mode.

During the third quarter of the grant period, we hope to complete instrument testing and study at least one high-temperature hydroxyl radical reaction using laser-induced fluorescence detection. We plan, in addition, further improvements in our quartz cell design. These modifications should extend our high-temperature kinetics capability to reactions involving molecules which decompose on, strongly adsorb to, or whose reactions are catalyzed by, metallic surfaces.

3/11/77

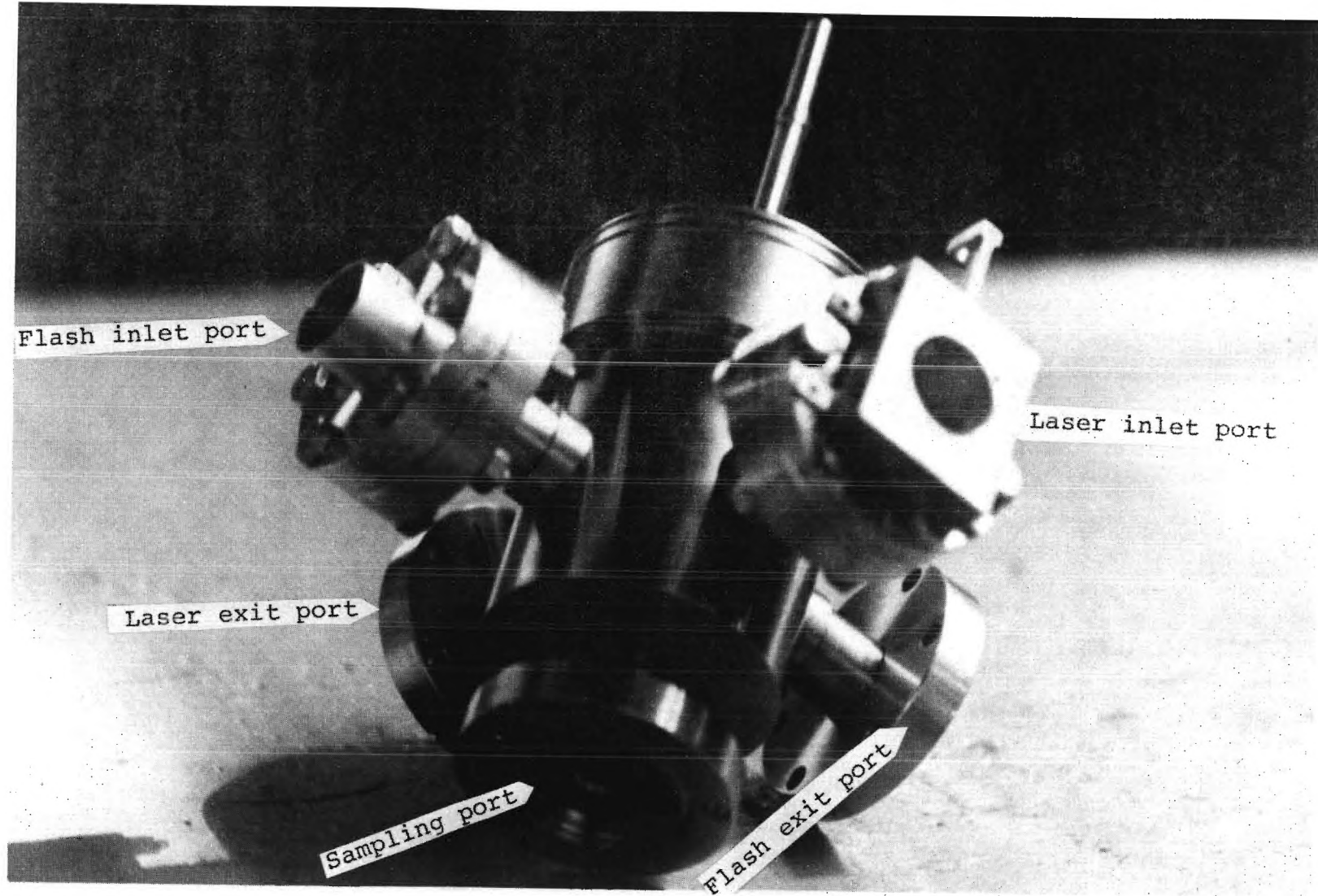

Figure 1: The new stainless steel high temperature reaction cell

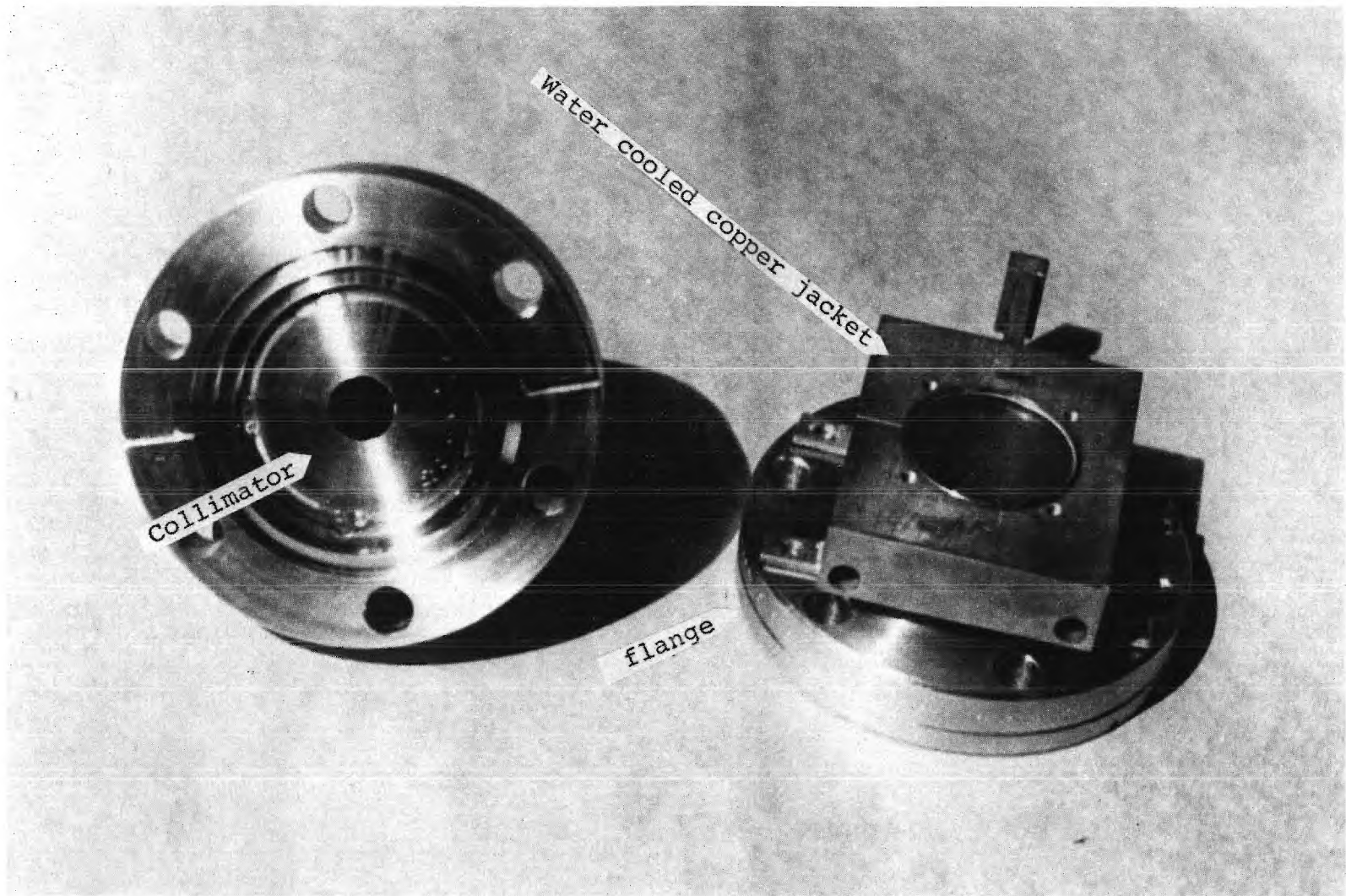

Figure 2: Water cooled, collimated reaction cell windows.

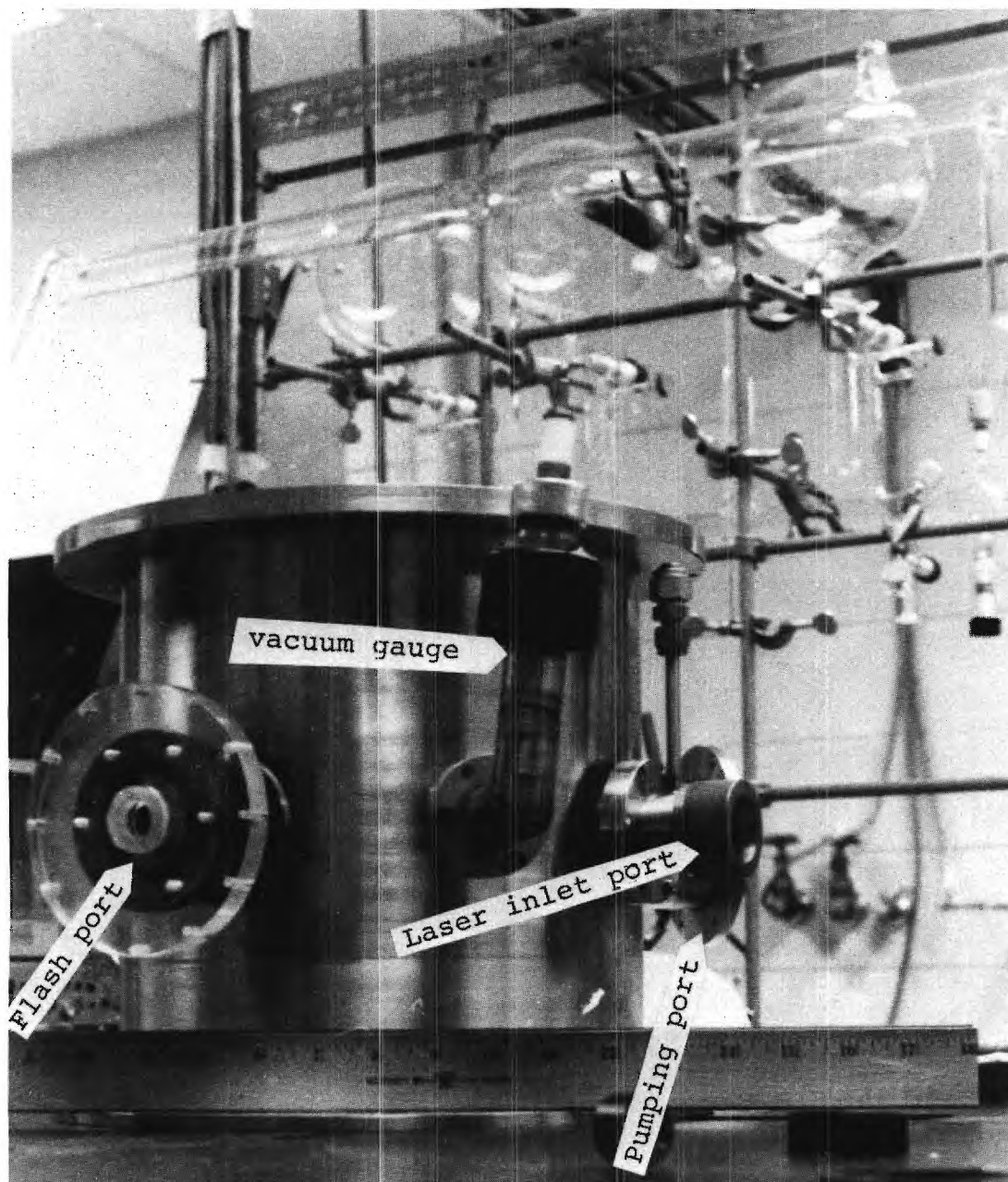

Figure 3: The new vacuum housing for the stainless steel high temperature reaction cell. (Note: The photomultiplier is located under the table.)

THIRD QUARTER PROGRESS REPORTNATIONAL BUREAU OF STANDARDS GRANT NO. GT - 9020

In our previous progress report, we described the nearly completed components of our new, high-temperature, stainless steel reaction kinetics system. In the period since our last report, fabrication of all parts has been completed, the system has been fully assembled, and optimization tests are presently underway. This new system incorporates several improvements, including enhancement of our flashlamp energy capability to over 1000 joules/flash. In the near future, we will undertake flash photolysis-resonance fluorescence experiments on the OH - CF₃Br(CF₄) systems.

On another front, the argon ion laser and its associated dye laser components have been ordered with State of Georgia funds. The availability of a CW tunable ultraviolet dye laser source in our OH kinetics program should greatly enhance our obtainable signal/noise, while virtually eliminating kinetic complications due to possible competing secondary reaction processes. We expect to have this laser system fully operational and interfaced with our high-temperature reaction cell in November.

Because of the slower than desired progress which has been made on this program, an eight-month performance period extension has been requested. The specific technical plans to be executed during this extension period are described in a separate document.



ENGINEERING EXPERIMENT STATION
GEORGIA INSTITUTE OF TECHNOLOGY • ATLANTA, GEORGIA 30332

October 28, 1977

Dr. Richard Gann
U.S. Department of Commerce
National Bureau of Standards
Washington, D. C. 20234

Dear Dick:

Enclosed you will find our fourth quarter progress report for NBS Grant GT-9020. We will keep in touch regarding further developments.

Sincerely,

A. R. Ravishankara

Frank P. Tully

FOURTH QUARTER PROGRESS REPORT

NATIONAL BUREAU OF STANDARDS GRANT NO. GT-9020

During the fourth quarter of the program we have measured the rate constant for the reaction of hydroxyl radicals with CF_3Br up to 673 K using resonance fluorescence detection. The rate constants are as follows:

$$300 \text{ K, 250 Torr He } k_1 = 6 \times 10^{-16} \text{ cm}^3 \text{ molecule}^{-1} \text{ s}^{-1}$$

$$523 \text{ K, 250 Torr He } (2.4 \pm 1.2) \times 10^{-15} \text{ cm}^3 \text{ molecule}^{-1} \text{ s}^{-1}$$

$$673 \text{ K, 250 Torr He } (3.2 \pm 1.6) \times 10^{-15} \text{ cm}^3 \text{ molecule}^{-1} \text{ s}^{-1}$$

The large error limits are due to two factors: (1) the flash photolysis-resonance fluorescence technique was operating at the limit of its capability to measure small rate constants, and (2) the sample of CF_3Br used in this study had $\sim 3\%$ CHF_3 as impurity. We have corrected our measured rate data for the presence of CHF_3 using the $\text{OH} + \text{CHF}_3$ rate constant obtained by C. J. Howard and K. M. Evenson (J. Chem. Phys., 64, 197, 1976). In considering the above rate constant values two further points should be noted: (1) as indicated by the invariance of the measured rate constant upon increasing the photolysis flash energy by a factor of four, photolysis of CF_3Br did not interfere with these measurements, and (2) the residence time of CF_3Br (and thus its pyrolysis) in the reactor at 673 K did not, within our experimental error, affect the measured rate constant.

Our development of a CW laser, designed to monitor OH, is proceeding smoothly. We have thus far been able to obtain visible laser output from the argon-ion pumped dye laser. This visible output has then been extra-cavity doubled to obtain the needed UV radiation. Presently, we are interfacing the laser system with our high temperature reactor. We expect to complete this task by the third week in November.

During the next three months we will measure the rate constants for OH reactions with H_2 and CH_4 . In addition, we will repeat our OH/ CF_3Br measurements with a purer sample of CF_3Br . All three of these reaction systems will be studied utilizing laser induced fluorescence detection.

U-771

A KINETICS INVESTIGATION OF SEVERAL REACTIONS
INVOLVING BROMINE COMPOUNDS AS RELATED TO FLAME
INITIATION AND PROPAGATION

FINAL TECHNICAL REPORT

GT-9020

B-477

Submitted to:

Office of Fire Programs
National Bureau of Standards
Washington, D.C. 20234

by

Engineering Experiment Station
Georgia Institute of Technology
Atlanta, Georgia 30332

The high temperature kinetics project was initiated at the University of Maryland, College Park, MD and later moved to Georgia Institute of Technology in 1976. (The renewal was funded through the Engineering Experiment Station at Georgia Tech.) Since its initiation, numerous personnel changes have taken place on the project, in addition to the physical moving of the apparatus from Maryland.

During the course of the work, attempts were made to adapt the conventional flash photolysis-resonance fluorescence technique to high temperature studies of OH reaction kinetics. The two major problems that needed to be overcome to successfully carry out this adaptation were related to the choice of material for reactor construction and the decrease in OH detection sensitivity (to unusable levels) at higher temperatures. Over the last four years, five different cell designs were tried. Each new design suggested further improvements. Finally, during the last 20 months, a "slow flow" all quartz graphite coated reactor which is resistively heated by tantalum windings inside ceramic insulators, has been employed. Extensive efforts were made to maximize OH detection by varying the position and focal length of lenses used to collimate the resonance lamp radiation and to collect the fluorescence. At present, 2×10^{10} OH cm⁻³ can be detected at 298K with a signal to noise of 1 with a 1 msec integration. At higher temperatures there is no significant loss in sensitivity. The detection limit obtained is probably near the maximum attainable sensitivity for OH using resonance fluorescence (laser induced fluorescence, of course, is considerably more sensitive). Currently, the higher temperature system is being used on two projects to carry out OH reaction studies.

Due to funding restrictions, the NBS project could not be completed as originally anticipated. However, this funding did initiate Georgia Tech's

attempts to carry out high temperature studies whose fruitful results will be obvious in forthcoming publications.

The attached manuscript describes the first high temperature (i.e., $T > 500\text{K}$) kinetics study of OH reactions using the flash photolysis-resonance fluorescence technique.

A brief attempt was made in 1978 to measure rate coefficients for the reaction,

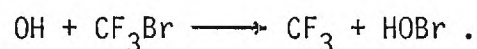

The obtained rate constants are as follows:

$$300\text{K}, 250 \text{ Torr He } \lesssim 6 \times 10^{-16} \text{ cm}^3 \text{ molecule}^{-1} \text{ s}^{-1}$$

$$523\text{K}, 250 \text{ Torr He } (2.41 \pm 1.2) \times 10^{-15} \text{ cm}^3 \text{ molecule}^{-1} \text{ s}^{-1}$$

$$673\text{K}, 250 \text{ Torr He } (3.2 \pm 1.6) \times 10^{-15} \text{ cm}^3 \text{ molecule}^{-1} \text{ s}^{-1}$$

The large error limits are due to two factors: (1) the flash photolysis-resonance fluorescence technique was operating at the limit of its capability to measure small rate constants, and (2) the sample of CF_3Br used in this study had $\sim 3\%$ CHF_3 as impurity. The measured rate data was corrected for the presence of CHF_3 using the $\text{OH} + \text{CHF}_3$ rate constant obtained by C.J. Howard and K.M. Evenson (J. Chem. Phys. 64, 197, 1976). In considering the above rate constant values two further points should be noted: (1) as indicated by the invariance of the measured rate constant upon increasing the photolysis flash energy by a factor of four, photolysis of CF_3Br did not interfere with these measurements, and (2) the residence time of CF_3Br (and thus its pyrolysis) in the reactor at 673K did not, within experimental error, affect the measured rate constant.

A Flash Photolysis-Resonance Fluorescence Kinetic
Study of the Reactions $\text{OH} + \text{H}_2 \rightarrow \text{H}_2\text{O} + \text{H}$ and
 $\text{OH} + \text{CH}_4 \rightarrow \text{H}_2\text{O} + \text{CH}_3$ from 298-1020K

F.P. Tully* and A.R. Ravishankara
Molecular Sciences Branch
Engineering Experiment Station
Georgia Institute of Technology
Atlanta, Georgia 30332

*Present address: Applied Physics Division
Sandia National Laboratories
Livermore, CA 94550

ABSTRACT

Absolute rate constants for the reactions $\text{OH} + \text{H}_2 \xrightarrow{k_1} \text{H}_2\text{O} + \text{H}$ (1) and $\text{OH} + \text{CH}_4 \xrightarrow{k_2} \text{H}_2\text{O} + \text{CH}_3$ (2) have been measured between 298-1020K using the flash photolysis-resonance fluorescence technique. These measurements represent the first use of this technique in kinetic studies of radical-molecule reactions above 500K. The obtained $k_1(T)$ and $k_2(T)$ values clearly demonstrate the existence of curvature in the Arrhenius graphs for the subject reactions. These data are compared with those of previous experiments and data evaluations on Reactions (1) and (2).

INTRODUCTION

Experimental measurements of absolute rate constants for radical-molecule reactions have historically been divided according to temperature regime. At low temperature ($T \lesssim 500\text{K}$) a variety of techniques¹ have been developed and utilized in recent years in response to the input demands of atmospheric chemical modeling. Generally speaking these techniques permit the adjustment of experimental conditions such that the absolute rate constant measurements for many specific radical-molecule reactions may be made with little, and/or quantifiable, interference from competing reaction processes. At high temperature ($T \gtrsim 1000\text{K}$) kinetic isolation of a given reaction has proven to be much more difficult to achieve. Experiments at flame temperatures typically range from studies utilizing end product analysis alone to investigations involving detailed concentration mapping vs. time (distance) of a number of radical (stable molecule) species whose interactive chemistry is very complex. Sequences of reaction schemes with parametrized absolute rate constant values are used to iteratively reproduce the measured concentration profiles (product yields). Frequently the extracted rate constants are model-dependent, ratioed to those of another insufficiently characterized reaction, or sensitive within only broad limits on the obtained raw data. The interpretive clarity of high temperature kinetic measurements has been observed to parallel the level of experimental control.

At temperatures intermediate between these separated regimes, 500-1000K, relatively few investigations of radical-molecule reaction rate constants have been undertaken. Two reactions which have received some attention^{2,3} in this interval as well as extensive study at high and low temperatures are the subject of the present investigation:

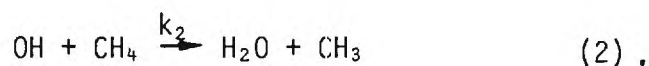
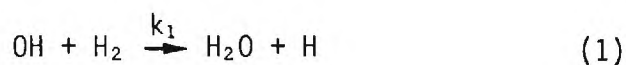

Published kinetic data on Reaction (1) has recently been critically evaluated and summarized by Cohen and Westberg.⁴ Based principally on kinetic measurements made below 500K and above 1000K, these authors recommend a three-parameter rate constant expression of functional form $k(T) = AT^n \exp(-E_0/RT)$ as an appropriate fit to the Arrhenius graph curvature experimentally defined for Reaction (1). Non-Arrhenius behavior is also evident in kinetic measurements made on Reaction (2). Zellner⁵ has used this same functional form to empirically effect a smooth joining of the low and high temperature rate constant measurements for this reaction.

In this paper we present the first in a series of studies of the reaction kinetics of the hydroxyl radical at intermediate temperatures. Using the direct kinetic technique of flash photolysis-resonance fluorescence absolute rate constants for Reactions (1) and (2) have been obtained up to temperatures of 1000K. These results will be described and compared with those of previous measurements and compilations.

EXPERIMENTAL SECTION

The application of the flash photolysis-resonance fluorescence technique to the study of OH radical reaction kinetics has been discussed previously.⁶ Hence we will describe the experimental apparatus briefly, emphasizing only those new features which for the first time extend the temperature range of applicability of the technique to above 1000K.

A schematic diagram of the experimental apparatus is shown in Figure 1. The principal components of this system are (1) a quartz

reaction cell resistively heated using electrically insulated tantalum wire windings mounted to its graphite-coated outer surface; (2) a spark discharge flashlamp perpendicular to one face of the cell; (3) a CW OH resonance lamp perpendicular to the photolysis beam; (4) a photomultiplier/bandpass filter combination for monitoring OH resonance fluorescence perpendicular to both the photolysis and resonance radiation beams; and (5) a signal averager and fast photon counting electronics.

The present experiments were carried out using a static reactor configuration. Typical gas mixtures consisting of 150 mtorr H₂O, 0-1 torr H₂(CH₄), and 50 Torr argon were flash photolyzed thereby initiating the primary reaction sequence

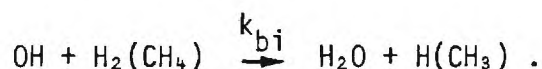
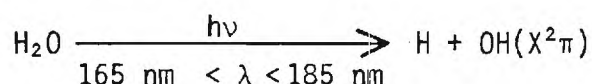

It is worth noting here that our use of Suprasil quartz optics with a transmission cutoff at 165 nm prevented photolysis of H₂ and CH₄⁷ and thus eliminated a major potential source of unwanted radicals and competing radical-radical reaction processes. Following the flash weakly focused resonance lamp radiation continuously excited a small fraction of the OH to the A²Σ⁺ state and the resultant (0,0) band fluorescence was counted in real time; the temporal profile of OH decay was constructed by signal averaging over a large number of flashes for each fixed reactant concentration. The reactant concentrations [H₂] and [CH₄] were maintained at large excess over [OH] ([OH]_{t=0} ≈ 1-5 × 10¹¹ molec/cm³) and the reaction kinetics were thus pseudo first order in [OH]. Exponential [OH] decays (through several 1/e times) were obtained, their time constants yielding the first order rate constant for OH disappearance at the re-

actant concentration of that mixture. Bimolecular rate constants were obtained as the slope of a plot of the measured first order rate constant vs. reactant concentration ($[H_2]$ or $[CH_4]$). System parameters such as flash energy, H_2O concentration and total pressure were varied to demonstrate the lack of importance of competing secondary processes in our measurements on Reactions (1) and (2). During the generation of most $[OH]$ decay curves several cycles of reactor filling/evacuation with identical gas mixtures were used so as to negate the kinetically deleterious effects of reactant depletion and product buildup (within the exposure limits used the measured rate constants were shown to be independent of the number of flashes to which any gas filling was subjected).

The two principal experimental factors which have permitted direct measurements of absolute rate constants to be made at temperatures in excess of 1000K involve the system optics configuration and the reaction cell design. Collimation and weak focusing of the incoming flashlamp and resonance lamp radiation and of the emitted fluorescence have been employed and have resulted in an OH detection sensitivity which is significantly enhanced relative to that available in previous high-pressure studies of Reactions (1) and (2). A detailed discussion of the detection sensitivity characteristics of a completely analogous experimental configuration is contained in a recent publication⁸ describing our laboratory's study of the $OH + NO_2 + M \rightarrow HNO_3 + M$ reaction. Highly polished Suprasil windows have been fused using quartz tape to an all quartz body to form the high-temperature reactor.⁹ Efficient heating and radiation shielding maintain a higher temperature at the body of the reactor than that at the protruding windows, the reaction temperature being measured by both internal (insertable) and external (body-

mounted) Chromel-Alumel thermocouples. During the period of measurement of each individual bimolecular rate constant the reactor temperature was held constant to within $\pm 3\text{K}$ by applying a controlled constant voltage to the resistive heaters. The temperature profile along the axis of the cylindrical reactor was measured using the retractable thermocouple at pressure conditions identical to those existing during kinetic measurements. The temperature differential between the upper and lower portions of the reaction zone (maximum length $\approx 2\text{ cm}$) was found to be $\leq 5\text{K}$ at a reactor temperature of 1000K . The bottom window (fluorescence port) temperature was measured to be $\approx 25\text{K}$ below that of the reaction zone at 1000K ; given the heater and radiation shield positions and the overall reactor geometry, side window temperatures are estimated to be comparable to that measured at the bottom window. Considering the relatively large reactor diameter used in this work (reactor volume $\approx 500\text{ cm}^3$), such temperature gradients are likely to be only a minimal source of experimental error.

Figure 2 shows typical OH decay profiles at three temperatures. These decay rates were all measured using the same diluent gas pressure, H_2O pressure, and photolysis flux. The high temperature experiments required longer periods of signal averaging than the lower temperature measurements; for example, twice as many flashes were needed at 1020K than at 619K to produce a good quality decay curve. At an H_2O partial pressure of $\sim 150\text{ mTorr}$ the fluorescence signal strength as a function of temperature was seen to scale closely with H_2O number density indicating minimal temperature dependent optics transmission effects; repeated temperature cycling of the reactor did, however, induce long-term degradation of the vacuum-UV transmission efficiency of the Suprasil windows.

[The static reactor used in the present work has since been replaced by an analogous "slow flow" high-temperature quartz reaction cell which transmits a continuously controlled flow of mixture of desired composition and thereby permits each initiating flash to encounter a "locally fresh" reaction mixture.]

The gases used in this study were obtained from Matheson Co. and had stated minimum purities as follows: H₂, 99.9999%; CH₄, 99.99%; and Ar, 99.9995%. Prior to their use, hydrogen and methane were passed through a trap at 77K to remove residual condensibles.

RESULTS AND DISCUSSION

The bimolecular reaction rate constants obtained in this study were generated from measurements of hydroxyl radical decay rates at several fixed reactant concentrations for each temperature. Plots of the first order decay constant vs. reactant concentration at selected temperatures between 499-1020 K are given for Reactions (1) and (2) in Figures 3 and 4, respectively. The bimolecular rate constants obtained as the slopes of the included least-square lines are listed with $\pm 2\sigma$ precision limits in Tables I and II. Room temperature rate constant values obtained in this work are in good agreement with those of previous studies tabulated in the data evaluations of References 4 and 5.

The major potential sources of systematic error in the measured values of k_1 and k_2 are the uncertainties in the reactant concentrations and in the temperature. At 298K the reactant concentrations of source mixtures could be determined quite accurately ($\approx 3\%$) using a capacitance manometer since both H₂ and CH₄ are non-sticky and non-condensable compounds. Reaction fillings were made using these calibrated source mixtures and elevated temperature reactant concentrations were calculated by scal-

ing accordingly to source mixture content and temperature. Including errors due to temperature uncertainties, then, the estimated error in reactant concentrations was $\leq 10\%$. Thus we estimate that the accuracies (95% confidence limit) of the measured values of k_1 and k_2 are $\sim 13\%$ at 298K increasing to $\sim 20\%$ at 1000K.

Our data for $k_1(T)$ are plotted along with selected previous results and analytical evaluations in Arrhenius graph form, $\ln k(T)$ vs. $1000/T$, in Figure 5. Our results cover a sufficiently wide temperature range to independently demonstrate the existence of curvature in the Arrhenius plot for Reaction (1). At low and relatively high temperature our measurements are in excellent agreement with the rate constant values calculated from Cohen and Westberg's summary expression⁴ $k_1(T) = 1.83 \times 10^{-15} T^{1.3} \exp(-1835/T) \text{ cm}^3 \text{ molec}^{-1} \text{ sec}^{-1}$. In the interval 499-648 K, however, measurements made in the present study fall about 20% below those derived from this $k_1(T)$ expression. Similarly, in the only previously published direct kinetic study of Reaction (1) at intermediate temperatures, Westenberg and deHaas² measured k_1 values between 403-745 K which averaged 22% below those calculated from the Cohen and Westberg formula. Interestingly Cohen and Westberg did not weight data at intermediate temperatures heavily in their evaluation; indeed, hardly any measurements between 500-1000 K were available. While our measurements yield generally very good agreement with the $k_1(T)$ values calculated from Cohen and Westberg's expression, they do suggest somewhat more pronounced Arrhenius graph curvature than that expression describes. The best fit expression calculated from our data only is $k_1(T) = 4.12 \times 10^{-19} T^{2.44} \exp(-1281/T) \text{ cm}^3 \text{ molec}^{-1} \text{ sec}^{-1}$. Zellner's suggested⁵ expression of $k_1(T) = 1.66 \times 10^{-16} T^{1.6} \exp(-1660/T) \text{ cm}^3 \text{ molec}^{-1} \text{ sec}^{-1}$ is perhaps the most appropriate fit to all available data. [With regard to curvature in Arrhenius plots it is of interest to note that preliminary

results of our $\text{OH} + \text{D}_2 \rightarrow \text{DHO} + \text{D}$ study¹⁰ between 298-932 K demonstrate markedly less Arrhenius graph curvature than that found to be appropriate for Reaction (1).]

Our rate constant measurements for the $\text{OH} + \text{CH}_4 \xrightarrow{k_2} \text{H}_2\text{O} + \text{CH}_3$ (2)

reaction are plotted along with selected previous work in Arrhenius graph form in Figure 6. Once again our data clearly demonstrates the existence of pronounced Arrhenius graph curvature for Reaction (2). Immediately apparent from this figure is the fact that straight-line extrapolations of either the low-temperature based NASA recommendation¹¹ or the high-temperature based Peeters and Mahnen recommendation¹² produce order of magnitude errors in $k_2(T)$ in the opposite temperature regime. Based principally on low- and high-temperature experimental measurements, Zellner⁵ derived an empirical best fit for $k_2(T)$ given by $k_2(T) = 2.57 \times 10^{-18} T^{2.3} \exp(-1233/T) \text{ cm}^3 \text{ molecule}^{-1} \text{ sec}^{-1}$. Within experimental error both our data (298-1020 K) and the single point of Ernst, Wagner and Zellner (1300K)¹³ fall dead-on the curve (solid line in Figure 6) traced out by this expression. Interestingly, the calculated best fit expression based on our data only, $k_2(T) = 1.32 \times 10^{-17} T^{1.92} \exp(-1355/T) \text{ cm}^3 \text{ molec}^{-1} \text{ sec}^{-1}$, yields a curve which is barely distinguishable from that recommended by Zellner. Indeed, given the quoted accuracies of these and previous measurements on Reaction (2), a rather extended array of parameters could be suggested as producing representative fits for $k_2(T)$. While the present experiments have demonstrated both the appropriateness of the functional form $k(T) = AT^n \exp(-E_0/RT)$ and the basic soundness of previous measurements in each separated temperature regime, the curve fitting calculations indicate that extreme caution must be exercised when attaching physical significance to multi-parameterized rate constant expressions.

At intermediate temperatures only one prior direct kinetic investigation of Reaction (2) has been undertaken. Using the technique of flash photolysis-resonance absorption, Zellner and Steinert³ measured $k_2(T)$ up to temperatures of 892K. At lower temperatures these data agree well with Zellner's empirical fit, but at higher temperatures their measured $k_2(T)$ values exceed the best fit values by a factor increasing with temperature and already more than two at 892K.

One possible explanation for the discrepancy at higher temperatures between Zellner and Steinert's results and those of the present study relates to the magnitude of the hydroxyl radical reactant concentration demanded by the resonance absorption and fluorescence detection modes. Although both techniques measure the disappearance of OH radicals in real time, the absorption technique monitors the difference between two large numbers $[(I_{t=0} - I_t)/I_{t=0}]$ and thereby requires much larger OH concentrations to match the statistics obtainable from the fluorescence technique. Thus Zellner and Steinert's initial post-flash OH concentrations were 40-100 times higher and their $[CH_4]/[OH]_{t=0}$ ratios were ~ 10 times lower than those characteristic of the present study. Such larger radical concentrations and lower reactant ratios enhance the probability of OH disappearance due to processes other than Reaction (2) and make more difficult kinetic isolation of this subject reaction. Based on sensitivity considerations, then, it appears that the fluorescence detection technique is best suited to the investigation of intermediate temperature hydroxyl radical reaction kinetics; indeed, it is the authors' opinion that present constraints on the general applicability of the flash photolysis-resonance fluorescence technique to combustion regime kinetics of O, H, and OH relate more to maintenance of the mechanical and optical

integrity of the experimental system than to limitations in detection sensitivity.

The experiments described above represent the first use of the flash photolysis-resonance fluorescence technique in the study of radical-molecule reaction kinetics above 500K. The need for direct kinetic investigations of prototype radical-molecule reactions from low temperatures to those well within the flame region is indisputable. Combustion modeling requires voluminous rate constant input from both direct measurement and extrapolation [note here the improvement in extrapolative accuracy achievable upon progression of data availability limits from 400K ($1000/T = 2.5$) to 1000K ($1000/T = 1.0$)]. Enhancement of our general understanding of bimolecular reaction rate theory is ultimately required to render practical the global kinetic approach to the chemical modeling of complex systems. Unambiguous rate constant studies over wide temperature ranges ($0.5 \leq 1000/T \leq 5.0$) will promote this goal.

ACKNOWLEDGEMENT

This work was supported by the Air Force Office of Scientific Research under Contract No. F49620-77-C-0111. Early stages of the apparatus development phase of this work were supported by the National Bureau of Standards through Grant No. GT-9020.

REFERENCES

1. (a) C. J. Howard, J. Phys. Chem. 83, 3(1979);
(b) J. V. Michael and J. H. Lee, J. Phys. Chem. 83, 10(1979);
(c) F. Kaufman, Ann. Rev. Phys. Chem. 30, 411(1979), and references therein.
2. A. A. Westenberg and N. deHaas, J. Chem. Phys. 58, 4061(1973).
3. R. Zellner and W. Steinert, Int. J. Chem. Kinet. 8, 397(1976).
4. N. Cohen and K. Westberg, J. Phys. Chem. 83, 46(1979).
5. R. Zellner, J. Phys. Chem. 83, 18(1979).
6. (a) D. D. Davis, S. Fischer, and R. Schiff, J. Chem. Phys. 59, 628(1974);
(b) A. R. Ravishankara, P. H. Wine, and A. O. Langford, J. Chem. Phys. 70, 984(1979), and references therein.
7. J. G. Calvert and J. N. Pitts, Jr., Photochemistry, John Wiley and Sons, Inc., 1966.
8. P. H. Wine, N. M. Kreutter, and A. R. Ravishankara, J. Phys. Chem. 83 3191(1979).
9. The reactor was fabricated by R and D Opticals Inc., New Windsor, Maryland.
10. A. R. Ravishankara, R. C. Shah, J. M. Nicovich, R. L. Thompson, and F. P. Tully, work in progress.
11. R. D. Hudson and E. I. Reed, The Stratosphere: Present and Future, NASA Reference Publication 1049, December 1979.
12. J. Peeters and G. Mahnen, 14th Symp. (Int.) Combustion, The Combustion Institute, p. 133 (1973).
13. J. Ernst, H. Gg. Wagner, and R. Zellner, Ber. Bunsenges. Phys. Chem. 82, 409(1978).

Table I.

Bimolecular Rate Constant vs. Temperature
for Reaction (1): $\text{OH} + \text{H}_2 \rightarrow \text{H}_2\text{O} + \text{H}$

<u>Temperature</u>	<u>$(\text{cm}^3 \text{ molec}^{-1} \text{ sec}^{-1})$ $k_{\text{bimolecular}}^*$</u>
298	$(6.08 \pm 0.37) \times 10^{-15}$
499	$(1.15 \pm 0.08) \times 10^{-13}$
576	$(2.34 \pm 0.18) \times 10^{-13}$
648	$(3.84 \pm 0.18) \times 10^{-13}$
739	$(7.64 \pm 0.56) \times 10^{-13}$
838	$(1.30 \pm 0.10) \times 10^{-12}$
904	$(1.86 \pm 0.35) \times 10^{-12}$
992	$(1.99 \pm 0.19) \times 10^{-12}$

* Stated Error Bounds Represent the 2σ Values

Table II.

Bimolecular Rate Constant vs. Temperature
for Reaction (2): $\text{OH} + \text{CH}_4 \rightarrow \text{H}_2\text{O} + \text{CH}_3$

<u>Temperature</u>	<u>$(\text{cm}^3 \text{molec}^{-1} \text{sec}^{-1})$ $k_{\text{bimolecular}}^*$</u>
298	$(7.50 \pm 0.60) \times 10^{-15}$
398	$(4.73 \pm 0.45) \times 10^{-14}$
448	$(8.1 \pm 1.1) \times 10^{-14}$
511	$(1.45 \pm 0.12) \times 10^{-13}$
529	$(1.67 \pm 0.06) \times 10^{-13}$
600	$(3.14 \pm 0.40) \times 10^{-13}$
619	$(2.75 \pm 0.44) \times 10^{-13}$
696	$(5.78 \pm 0.58) \times 10^{-13}$
772	$(8.4 \pm 1.5) \times 10^{-13}$
915	$(1.50 \pm 0.15) \times 10^{-12}$
1020	$(2.00 \pm 0.20) \times 10^{-12}$

* Stated Error Bounds Represent the 2σ Values

FIGURE CAPTIONS

- Fig. 1. Schematic drawing of the experimental apparatus. (For clarity the flashlamp and resonance lamp are pictured at 180° to each other whereas in reality they were situated at 90°).
- Fig. 2. Typical OH temporal profiles observed following flash photolysis of $\text{H}_2\text{O}/\text{CH}_4/\text{diluent}$ mixtures. Experimental conditions: $P = 50$ Torr, diluent = Ar, flash energy = 120 J, H_2O pressure = 150 mTorr. The concentrations of methane, temperature, and the number of traces averaged are shown next to each line.
- Fig. 3. Plot of the first order rate constant versus the H_2 concentration for Reaction (1) at several temperatures.
- Fig. 4. Plot of the first order rate constant versus the CH_4 concentration for Reaction (2) at several temperatures.
- Fig. 5. Arrhenius graph for Reaction (1).
- Fig. 6. Arrhenius graph for Reaction (2).

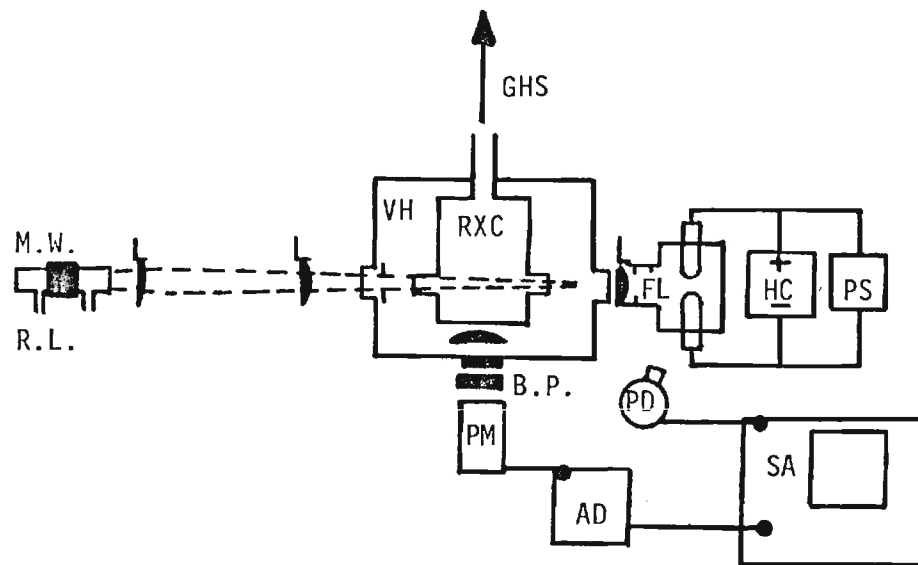

- | | |
|--|----------------------|
| AD: AMPLIFIER/DISCRIMINATOR | PD: PHOTODIODE |
| B.P.: BANDPASS FILTER | PM: PHOTOMULTIPLIER |
| FL: FLASHLAMP | PS: POWER SUPPLY |
| GHS: GAS HANDLING SYSTEM | R.L.: RESONANCE LAMP |
| HC: HIGH VOLTAGE CAPACITOR | RXC: REACTION CELL |
| L: LENS | VH: VACUUM HOUSING |
| M.W.: MICROWAVE CAVITY
(Evenson Type) | SA: SIGNAL AVERAGER |

Figure 1.

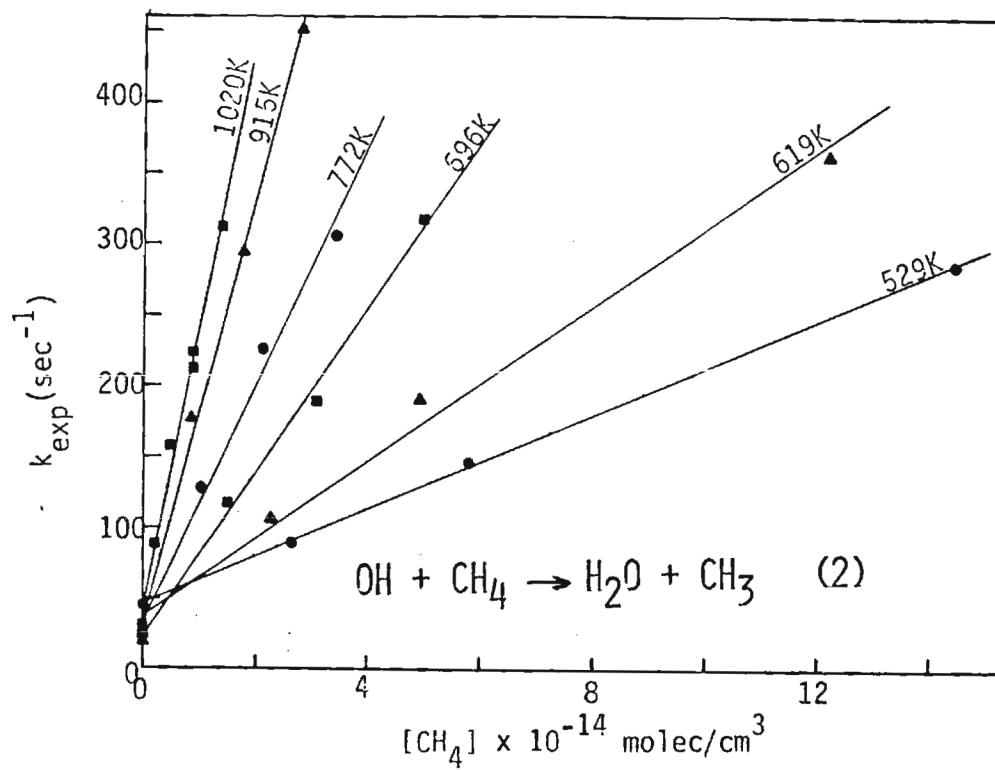

Figure 4.

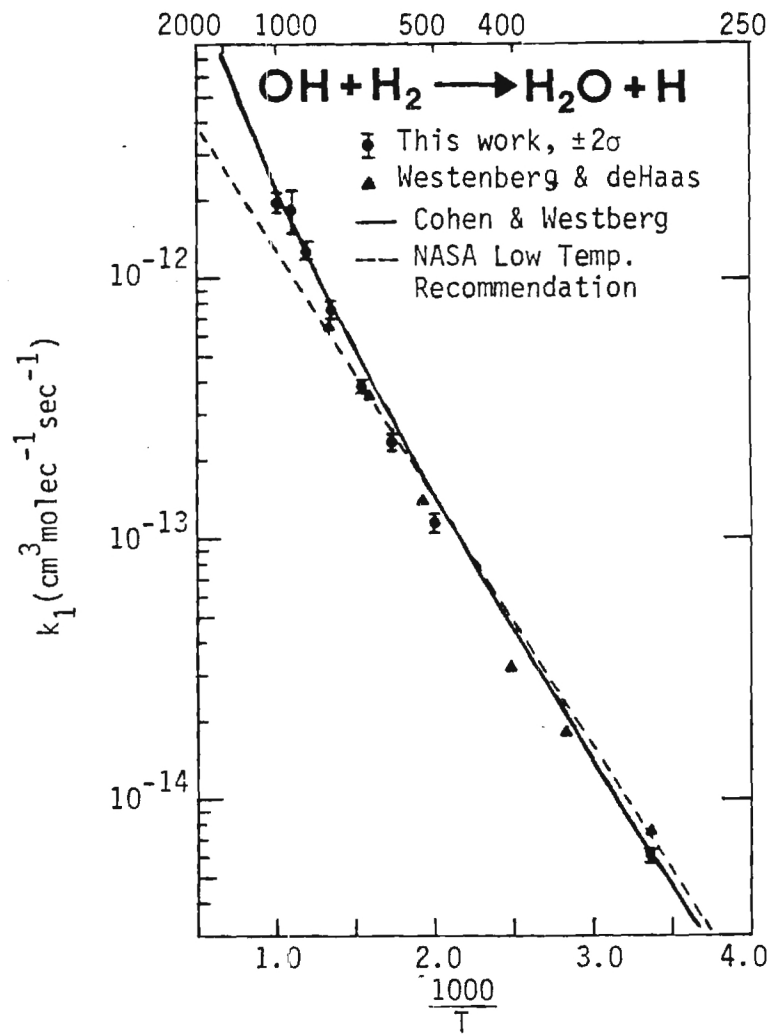

Figure 5.

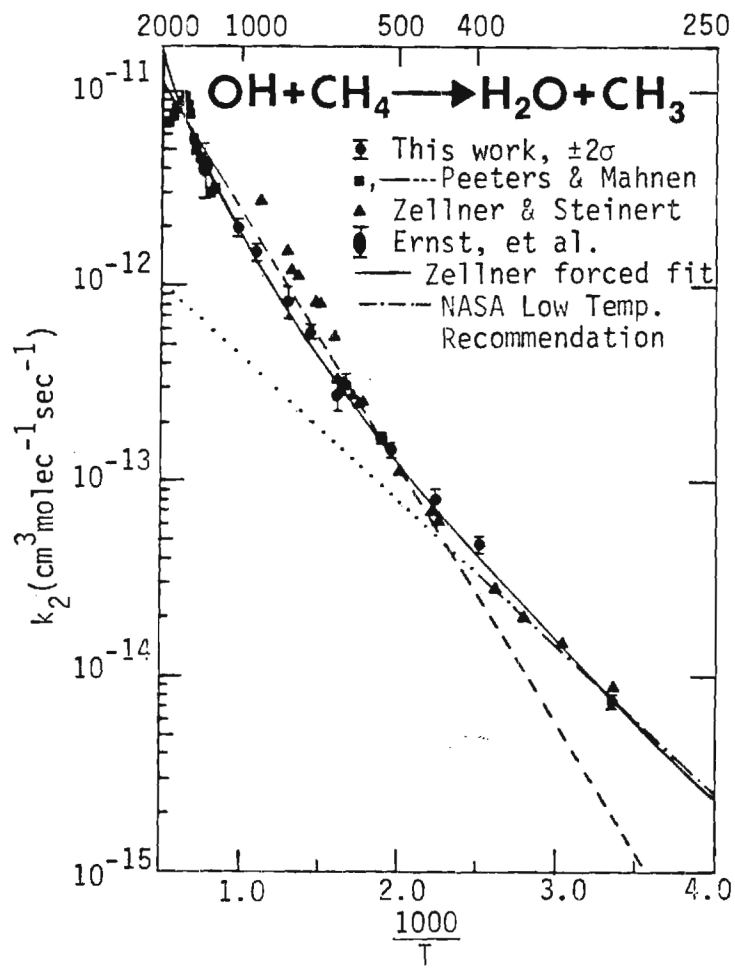

Figure 6.