

**Investigation of the vasoprotective role of
C-type natriuretic peptide**

Rayomand Syrus Khambata

A thesis submitted in part fulfilment for the Degree of Doctor of
Philosophy in University College London

Declaration of ownership

I, Rayomand Syrus Khambata, declare that this thesis is the result of my own work.
All help and advice has been acknowledged and primary and secondary sources of
information have been properly attributed.

Abstract

Background

Ischaemic cardiovascular disease, including myocardial infarction and stroke, is the leading cause of morbidity and mortality worldwide. Atherosclerosis and coronary artery disease, which underpin ischaemic cardiovascular disorders, are characterised by chronic inflammation of the blood vessel wall and endothelial dysfunction. C-type natriuretic peptide (CNP) has recently been identified as an endothelium-derived hyperpolarising factor with anti-atherogenic properties. The studies described herein investigated the hypothesis that the vasoprotective profile of CNP includes opposing effects on endothelial and vascular smooth muscle cell proliferation and regulation of blood pressure.

Methods

Cellular incorporation of bromodeoxyuridine was used to determine cell proliferation and immunoblotting was employed to assess expression/activity of intracellular signalling proteins in human umbilical vein endothelial cells (HUVEC) and rat aortic smooth muscle cells (RAoSMC). An endothelium specific CNP knockout (ecCNP KO) mouse model was developed and organ bath pharmacology utilised to assess vascular reactivity *in vitro*, and radiotelemetric monitoring used to determine blood pressure *in vivo*.

Principal findings

CNP augmented HUVEC proliferation in a natriuretic peptide receptor (NPR)-C-dependent fashion by up-regulating the cell cycle promoter, cyclin D1. In contrast, CNP increased expression of the cell cycle inhibitors p21^{waf1/cip1}/p27^{kip1} in RAoSMC and reduced cell growth; the pro- and anti-mitogenic effects of CNP were mediated in an extracellular signal-regulated kinase (ERK) 1/2-dependent manner. Vascular reactivity and endothelial function were disrupted in isolated aortae from female ecCNP KO mice compared to WT, whilst in males was unchanged. Female ecCNP KO mice were hypertensive.

Conclusions

The anti-atherogenic properties of CNP are mediated in part by NPR-C and ERK 1/2 signalling, resulting in a differential regulation of cell cycle proteins that promotes endothelial cell proliferation and inhibits smooth muscle cell growth. Moreover, endothelium-derived CNP is key to blood pressure regulation in females. These data suggest that targeting CNP/NPR-C signalling may represent a novel approach for the treatment of cardiovascular disease.

Acknowledgements

This thesis marks the end of approximately 20 years of study and regrettably of my student status, which now means I have to pay tax and NI, an unfortunate reality.

First and foremost I would like to thank Dr Adrian Hobbs for the invaluable help and guidance he has given me throughout my PhD. Adrian's door has always been open and he has been the best supervisor a student could hope for.

I would also like to acknowledge the Hobbs group and Leanne for their friendship and help throughout my time at UCL. Also, my partner Valerie for her support and our enlightening (geeky) conversations; as my bro says I am a geek. However, within the last few months on two separate occasions I have been told by people, that I had just met, that I wasn't geeky for a scientist. Result!

Finally I thank my mum, dad and bro who still don't quite get what I do, but at least are now familiar with the term pharmacology, which was somewhat of a mystery when I suggested I wanted to study it at university, 8 years ago.

Table of Contents

Title.....	1
Declaration of ownership.....	2
Abstract.....	3
Acknowledgements.....	5
Table of Contents.....	6
Table of Figures.....	11
Table of Tables.....	15
Abbreviations.....	16

Chapter 1

1 INTRODUCTION.....	21
1.1 Cardiovascular disease.....	21
1.1.1 Background.....	21
1.1.2 Atherosclerosis.....	21
1.1.3 Restenosis.....	23
1.2 Endothelial function.....	25
1.2.1 Nitric Oxide.....	26
1.2.2 Prostacyclin.....	27
1.2.3 Endothelium-derived hyperpolarising factor.....	28
1.2.4 Endothelin-1.....	29
1.3 Natriuretic peptides.....	29
1.3.1 Discovery.....	30
1.3.2 Structure and synthesis.....	30
1.3.3 Atrial natriuretic peptide.....	30
1.3.4 Brain natriuretic peptide.....	32
1.3.5 C-type natriuretic peptide.....	32
1.3.6 Urodilatin and dendroaspis natriuretic peptide.....	33
1.3.7 Natriuretic peptide receptors.....	33
1.3.7.1 Natriuretic peptide receptor-A.....	34

1.3.7.2	Natriuretic peptide receptor-B.....	34
1.3.7.3	Natriuretic peptide receptor-C.....	35
1.3.8	Clearance of natriuretic peptides.....	36
1.4	Cardiovascular roles of CNP	37
1.4.1	Expression and distribution.....	37
1.4.2	Vasodilatation	38
1.4.3	Blood pressure regulation	40
1.4.4	Interaction between CNP and the renin-angiotensin-aldosterone-system.....	41
1.4.5	Regulation of leukocyte and platelet reactivity.....	42
1.4.6	CNP in atherosclerosis and restenosis.....	43
1.4.7	Vascular cell proliferation.....	44
1.5	Regulation of cell growth.....	46
1.5.1	Mitogen-activated protein kinases	46
1.5.1.1	ERK 1/2.....	47
1.5.1.1.1	ERK 1/2 and endothelial cell proliferation	47
1.5.1.1.2	ERK 1/2 and vascular smooth muscle cell growth	47
1.5.1.2	p38.....	48
1.5.1.2.1	p38 and endothelial cell proliferation	48
1.5.1.2.2	p38 and vascular smooth muscle cell growth	48
1.5.1.3	JNK/SAPK.....	49
1.5.1.3.1	JNK/SAPK and endothelial cell proliferation.....	49
1.5.1.3.2	JNK/SAPK and vascular smooth muscle cell growth.....	49
1.5.2	Phosphatidylinositol-3 Kinase	49
1.5.2.1	PI3K and endothelial cell proliferation	50
1.5.2.2	PI3K and vascular smooth muscle cell growth.....	51
1.6	The cell cycle.....	51
1.6.1	CNP and cell cycle proteins	53
1.7	Aims.....	54
Chapter 2		
2	METHODS.....	56

2.1	Materials	56
2.2	Cell Culture	56
2.2.1	Human umbilical vein endothelial cell	56
2.2.2	Primary rat aortic smooth muscle cell isolation	57
2.2.3	Biomagnetic purification of mouse pulmonary microvascular endothelial cells.....	57
2.2.4	Freezing cells	59
2.2.5	Thawing cells	59
2.3	Measurement of endothelial cell proliferation	59
2.4	Determination of MAPK phosphorylation and cell cycle proteins.....	60
2.5	Sample preparation.....	61
2.6	Sodium dodecyl sulphate polyacrylamide gel electrophoresis (SDS PAGE)	61
2.7	Immunoblotting.....	62
2.8	Endothelium specific CNP knockout mouse.....	63
2.8.1	Generation of endothelium specific CNP knockout mouse	63
2.8.2	Genotyping of animals	65
2.9	Mouse isolated thoracic aorta	67
2.10	Mouse blood pressure recording.....	67
2.11	Statistics	68

Chapter 3

3	RESULTS 1.....	70
3.1	Introduction.....	70
3.2	Defining optimum conditions for measuring CNP-induced HUVEC proliferation.....	71

3.3	CNP-induced HUVEC proliferation is part NPR-C mediated	74
3.4	Determination of the signalling pathway responsible for CNP-induced HUVEC proliferation	78
3.5	CNP induces ERK 1/2 and Akt phosphorylation in HUVEC	81
3.6	NPR-C activation underlies CNP-induced ERK 1/2 and Akt phosphorylation in HUVEC	84
3.7	CNP does not activate eNOS in HUVEC	89
3.8	CNP alters cell cycle protein expression in HUVEC in an ERK 1/2-dependent manner.....	91
3.9	CNP alters cell cycle protein expression in RAoSMC in an ERK 1/2-dependent manner.....	95
3.10	Summary of key findings.....	101

Chapter 4

4	RESULTS 2.....	103
4.1	Introduction	103
4.2	Initial characterisation of WT and ecCNP KO mice	104
4.3	Effect of endothelial CNP gene knockout on functional reactivity of thoracic aorta.....	108
4.3.1	Contractile agonists	108
4.3.2	Vasorelaxants	108
4.4	Effect of endothelial CNP gene knockout on functional reactivity of mesenteric artery.....	119
4.5	Effect of endothelial CNP gene knockout on blood pressure, heart rate and activity.....	122
4.5.1	Blood pressure.....	122
4.5.2	Heart rate	122

4.5.3	Activity.....	122
4.6	Summary of key results	127

Chapter 5

5	DISCUSSION	129
5.1	Summary of key findings.....	129
5.2	CNP as a regulator of endothelial cell proliferation	129
5.3	CNP as a regulator of VSMC proliferation	132
5.4	The role of CNP in cardiovascular homeostasis.....	135
5.5	Sex differences in cardiovascular disease	139
5.6	CNP and cardiovascular disease.....	140
5.6.1	Role of CNP in atherosclerosis: Potential therapy	140
5.6.2	Restenosis.....	145
5.6.3	Vein graft disease prevention.....	147
5.6.4	Ischaemia/reperfusion injury.....	148
5.7	Angiogenesis and revascularisation.....	149
5.8	Interaction between nitric oxide and CNP in the vasculature	150
5.9	Conclusions	152

Chapter 6

6	REFERENCES	154
----------	-------------------------	------------

Table of Figures

Figure 1 - An overview of the development of atherosclerosis.	22
Figure 2 - Balloon angioplasty, stent deployment and restenosis.....	24
Figure 3 - cGK-mediated smooth muscle relaxation	27
Figure 4 - A schematic showing the primary structure of the natriuretic peptides.....	31
Figure 5 - Structure and homology of the natriuretic peptide receptors	35
Figure 6 - Proposed EDHF pathways present in rat mesenteric arteries.....	40
Figure 7 - Principle MAPK pathways.....	46
Figure 8 - An overview of the cell cycle.....	52
Figure 9 - Flow cytometry analysis of PMEC	58
Figure 10 - Schematic representation of the generation of ecCNP KO mice	64
Figure 11 - Schematic representation of Floxed CNP primers binding sites and expected product sizes.....	66
Figure 12 - BrdU incorporation in response to CNP (1 μ M) for 24 h in HUVEC	72
Figure 13 - BrdU incorporation in response to CNP (1 μ M) for 48 h in HUVEC	73
Figure 14 - BrdU incorporation in response to CNP (1 pM - 1 μ M) and cANF ⁴⁻²³ (1 pM - 1 μ M; both 24 h) in HUVEC	75
Figure 15 - BrdU incorporation in response to CNP (100 pM) and cANF ⁴⁻²³ (100 pM; both 24 h) in HUVEC in the absence and presence of M372049 (10 μ M)	76
Figure 16 - BrdU incorporation in (A) CNP (100 pM; 24 h) treated and (B) non- treated PMEC	77
Figure 17 - BrdU incorporation in response to CNP (100 pM; 24 h) in HUVEC in the absence and presence of (A) PD98059 (30 μ M), (B) SB203580 (30 μ M) or (C) SP600125 (3 μ M).....	79
Figure 18 - BrdU incorporation in response to CNP (100 pM; 24h) in HUVEC in the absence and presence of (A) LY294002 (10 μ M), or (B) wortmannin (500 nM)	80
Figure 19 - Expression and phosphorylation of ERK 1/2 in response to CNP (100 pM) for 0 - 24 h in HUVEC.....	82
Figure 20 - Expression and phosphorylation of Akt in response to CNP (100 pM) for 0 - 24 h in HUVEC	83

Figure 21 - Expression and phosphorylation of ERK 1/2 in response to CNP (100 pM; 30 min) in HUVEC in the absence and presence of M372049 (10 μM).....	85
Figure 22 - Expression and phosphorylation of ERK 1/2 in response to CNP (100 pM; 30 min) in HUVEC in the absence and presence of PTx (100 ng/ml).....	86
Figure 23 - Expression and phosphorylation of Akt in response to CNP (100 pM; 30 min) in HUVEC in the absence and presence of M372049 (10 μM)	87
Figure 24 - Expression and phosphorylation of Akt in response to CNP (100 pM; 30 min) in HUVEC in the absence and presence of PTx (100 ng/ml)	88
Figure 25 - Expression and phosphorylation of eNOS in HUVEC in response to CNP (100 pM; 30 min).....	90
Figure 26 - Expression of cyclin D1 in response to CNP (100 pM) for 0 - 24 h in HUVEC	92
Figure 27 - Expression of p21 ^{waf1/cip1} in response to CNP (100 pM) for 0 – 24 h in HUVEC	93
Figure 28 - Expression of cyclin D1 in response to CNP (100 pM; 24 h) in HUVEC in the absence or presence of PD98059 (30 μM)	94
Figure 29 - Expression of p21 ^{waf1/cip1} in response to CNP (1 μM) for 0 - 24 h in RAoSMC	96
Figure 30 - Expression of p27 ^{kip1} in response to CNP (1 μM) for 0 - 24 h in RAoSMC	97
Figure 31 - Expression of cyclin D1 in response to CNP (1 μM) for 0 - 24 h in RAoSMC	98
Figure 32 - Expression of p21 ^{waf1/cip1} in response to CNP (1 μM; 24 h) in RAoSMC in the absence or presence of PD98059 (30 μM).....	99
Figure 33 - Expression of p27 ^{kip1} in response to CNP (1 μM; 24 h) in RAoSMC in the absence or presence of PD98059 (30 μM)	100
Figure 34 - Genotyping of WT and ecCNP KO mice.....	105
Figure 35 - Body mass of male WT and ecCNP KO mice aged 6 to 16 weeks old...	106
Figure 36 - Body mass change in male WT and ecCNP KO mice between 6 and 16 weeks old.....	106

Figure 37 - Body mass of female WT and ecCNP KO mice aged 6 to 16 weeks old.....	107
Figure 38 - Body mass change in female WT and ecCNP KO mice aged 6 to 16 weeks old.....	107
Figure 39 - Concentration-response curves to PE in aortic rings from male WT and ecCNP KO mice	109
Figure 40 - Concentration-response curves to PE in aortic rings from female WT and ecCNP KO mice	110
Figure 41 - Concentration-response curves to U46619 in aortic rings from male WT and ecCNP KO mice	111
Figure 42 - Concentration-response curves to U46619 in aortic rings from female WT and ecCNP KO mice	112
Figure 43 - Concentration-response curves to ACh in aortic rings from male WT and ecCNP KO mice	113
Figure 44 - Concentration-response curves to ACh in aortic rings from female WT and ecCNP KO mice	114
Figure 45 - Concentration-response curves to CNP in aortic rings from male WT and ecCNP KO mice	115
Figure 46 - Concentration-response curves to CNP in aortic rings from female WT and ecCNP KO mice	116
Figure 47 - Concentration-response curves to Sper-NO in aortic rings from male WT and ecCNP KO mice	117
Figure 48 - Concentration-response curves to Sper-NO in aortic rings from female WT and ecCNP KO mice	118
Figure 49 - Concentration-response curves to ACh in mesenteric arteries from male WT and ecCNP KO mice in the presence of L-NAME and indomethacin	120
Figure 50 - Concentration-response curves to ACh in mesenteric arteries from female WT and ecCNP KO mice in the presence of L-NAME and indomethacin	121
Figure 51 - Circadian rhythm of MABP in male WT and ecCNP KO mice	123
Figure 52 - Circadian rhythm of MABP in female WT and ecCNP KO mice	123
Figure 53 - MABP of male WT and ecCNP KO mice.....	124
Figure 54 - MABP of female WT and ecCNP KO mice.....	124

Figure 55 - Heart rate of male WT and ecCNP KO mice	125
Figure 56 - Heart rate of female WT and ecCNP KO mice.....	125
Figure 57 - Activity of male WT and ecCNP KO mice.....	126
Figure 58 - Activity of female WT and ecCNP KO mice.....	126
Figure 59 - Signalling pathway by which CNP mediates vascular cell proliferation.....	132
Figure 60 - The beneficial actions of endothelium-derived CNP	147

Table of Tables

Table 1 - Dissociation constants (K_d) for binding of human natriuretic peptides to human natriuretic peptide receptors.....	34
Table 2 - Name and sequence of primers used to genotype offspring.....	66
Table 3 - pEC ₅₀ and E _{max} values of PE in aortic rings from male WT and ecCNP KO mice	109
Table 4 - pEC ₅₀ and E _{max} values of PE in aortic rings from female WT and ecCNP KO mice	110
Table 5 - pEC ₅₀ and E _{max} values of U46619 in aortic rings from male WT and ecCNP KO mice	111
Table 6 - pEC ₅₀ and E _{max} values of U46619 in aortic rings from female WT and ecCNP KO mice	112
Table 7 - pEC ₅₀ and E _{max} values of ACh in aortic rings from male WT and ecCNP KO mice	113
Table 8 - pEC ₅₀ and E _{max} values of ACh in aortic rings from female WT and ecCNP KO mice	114
Table 9 - pEC ₅₀ and E _{max} values of CNP in aortic rings from male WT and ecCNP KO mice	115
Table 10 - pEC ₅₀ and E _{max} values of CNP in aortic rings from female WT and ecCNP KO mice	116
Table 11 - pEC ₅₀ and E _{max} values of Sper-NO in aortic rings from male WT and ecCNP KO mice	117
Table 12 - pEC ₅₀ and E _{max} values of Sper-NO in aortic rings from female WT and ecCNP KO mice	118
Table 13 - pEC ₅₀ and E _{max} values of ACh in mesenteric arteries from male WT and ecCNP KO mice in the presence of L-NAME and indomethacin....	120
Table 14 - pEC ₅₀ and E _{max} values of ACh in mesenteric arteries from female WT and ecCNP KO mice in the presence of L-NAME and indomethacin....	121

Abbreviations

ACh	Acetylcholine
Ang	Angiotensin
ANP	Atrial natriuretic peptide
ASK	Apoptosis-signal regulating kinase
Ba ²⁺	Barium
BAEC	Bovine aortic endothelial cell
BCAEC	Bovine coronary artery endothelial cell
bFGF	Basic fibroblast growth factor
BK _{Ca}	Large-conductance calcium activated channel
BMS	Bare metal stent
BNP	Brain natriuretic peptide
BrdU	5-bromo-2'-deoxyuridine
[Ca ²⁺] _i	Intracellular Ca ²⁺ concentration
CaM	Calmodulin
cAMP	Cyclic adenosine-3',5'- monophosphate
cANF ⁴⁻²³	des(Gln ¹⁸ , Ser ¹⁹ , Gly ²⁰ , Leu ²¹ , Gly ²²)-ANP fragment 4-23
CDK	Cyclin dependent kinase
cGK	Cyclic guanosine-3',5'-monophosphate-dependent protein kinase
cGMP	Cyclic guanosine-3',5'-monophosphate
CKI	Cyclin dependent kinase inhibitor
CNP	C-type natriuretic peptide
COX	Cyclooxygenase
CVD	Cardiovascular disease
DAG	Diacylglycerol
DES	Drug eluting stent
DMEM	Dulbecco's Modified Eagle Medium
DMSO	Dimethyl sulphoxide
DNP	Dendroaspis natriuretic peptide
EDHF	Endothelium-derived hyperpolarising factor
eNOS	Endothelial nitric oxide synthase
ERK	Extracellular signal-regulated kinase

ET	Endothelin
F12	Nutrient mixture F12
FCS	Fetal calf serum
G1	First gap
G2	Second gap
Gax	Growth arrest-specific homeobox
GC	Guanylyl cyclase
GTP	Guanosine-5'-triphosphate
HCAEC	Human coronary artery endothelial cell
HDL	High density lipoprotein
HIF	Hypoxia inducible factor
HUVEC	Human umbilical vein endothelial cell
ICAM	Intercellular adhesion molecule
IFN	Interferon
IL	Interleukin
iNOS	Inducible nitric oxide synthase
IP ₃	Inositol 1,4,5-triphosphate
I/R	Ischaemia/reperfusion
JNK	C-Jun N-terminal kinase
K _{IR}	Inwardly rectifying K ⁺ channel
KO	Knockout
LDL	Low density lipoprotein
LPS	Lipopolysaccharide
L-NAME	N ^G -nitro-L-arginine methyl ester
L-NMA	N ^G -methyl-L-arginine
L-NNA	N ^G -nitro-L-arginine
M	Mitosis
MABP	Mean arterial blood pressure
MAPK	Mitogen-activated protein kinase
MCP	Monocyte chemoattractant protein
MEK	Mitogen-activated protein kinase/extracellular-signal regulated kinase
MI	Myocardial infarction
MKK	Mitogen-activated protein kinase kinase
MKKK	Mitogen-activated protein kinase kinase kinase

MLCK	Myosin light chain kinase
MLCP	Myosin light chain phosphatase
MLK	Mixed linkage kinase
mTOR	Mammalian target of rapamycin
nNOS	Neuronal nitric oxide synthase
NO	Nitric oxide
NPR	Natriuretic peptide receptor
ODQ	1H-[1,2,4]oxadiazolo[4,3-a]quinoxalin-1-one
PAI	Plasminogen activator inhibitor
PCI	Percutaneous coronary intervention
PDE	Phosphodiesterase
PDGF	Platelet derived growth factor
PE	Phenylephrine
PECAM	Platelet endothelial cellular adhesion molecule
PGI ₂	Prostacyclin
PI3K	Phosphatidylinositol-3 kinase
PIP ₂	Phosphatidylinositol 4,5-biphosphate
PKA	Cyclic adenosine-3',5'-monophosphate-dependent protein kinase
PKB	Protein kinase B
PKC	Protein kinase C
PMEC	Pulmonary microvascular endothelial cells
RAAS	Renin-angiotensin-aldosterone system
RAoSMC	Rat aortic smooth muscle cell
S	Synthesis
SAPK	Stress-activated protein kinase
SDS PAGE	Sodium dodecyl sulphate polyacrylamide gel electrophoresis
Sper-NO	Spermine-NONOate
TAK	Transforming growth factor- β -activated protein kinase
TEMED	N,N,N',N'-tetramethylethylenediamine
TGF	Transforming growth factor
TNF	Tumour necrosis factor
VCAM	Vascular cell adhesion molecule
VEGF	Vascular endothelial growth factor
VSMC	Vascular smooth muscle cell

WHO World Health Organisation

WT Wild type

Chapter 1

Introduction

1 Introduction

1.1 Cardiovascular disease

1.1.1 Background

In 2003, cardiovascular disease (CVD) led to the death of approximately 16.7 million people worldwide or 29.2 % of total global deaths (World Health Organisation, 2010). CVD is the leading cause of mortality in developed countries and this year (2010), the WHO estimates that CVD will also be the principal cause of death in developing countries (World Health Organisation, 2010). In England, over the past 40 years, the mortality rate due to CVD has been reduced from approximately 260 to 80 per 100,000 population; yet, in 2008 there were still 198,000 deaths in the UK, as a result of CVD (Department of Health, 2008;British Heart Foundation, 2008b). The predominant forms of CVD are myocardial infarction (MI) and stroke which accounted for approximately 48 % and 28 %, respectively, of deaths from CVD in the UK in 2008 (British Heart Foundation, 2008b). These staggering statistics indicate that there is a clear unmet clinical need in the prevention and treatment of CVD.

1.1.2 Atherosclerosis

Atherosclerosis is an inflammatory disease of the blood vessel wall characterised by lipid deposition, cell recruitment and plaque formation, leading to occlusion of the vessel and distal ischaemia (Figure 1; Ross 1999). In the coronary arteries this process (coronary artery disease) leads to MI, whereas in the cerebral circulation, atherosclerosis results in stroke. Endothelial cell activation, the initiating process in the development of atherosclerosis, is caused by infiltration and retention of low density lipoprotein (LDL) into the arterial intima (Ku *et al.*, 1985;Steinberg, 1997;Skalen *et al.*, 2002); this is accelerated in areas with turbulent blood flow and hence low shear stress (Ku *et al.*, 1985), such as bifurcation branches. Activated endothelial cells express several cell adhesion molecules including vascular cell adhesion molecule (VCAM)-1, intercellular adhesion molecule (ICAM)-1, platelet endothelial cell adhesion molecule (PECAM)-1, P-selectin and E-selectin, which promote leukocyte and platelet rolling and adhesion along the endothelium (Johnson *et al.*, 1997;Nageh *et al.*, 1997;Dong *et al.*, 1998;Cybulsky *et al.*, 2001;Stevens *et al.*,

2008). Adherent monocytes and T-lymphocytes migrate into the intimal smooth muscle layer of the artery, down a chemotactic gradient, produced by various chemokines such as monocyte chemoattractant protein (MCP)-1, Regulated on Activated Normal T-cell Expressed and Secreted (RANTES/CCL5) and fractalkine (Boring *et al.*, 1998; Lesnik *et al.*, 2003; Veillard *et al.*, 2004).

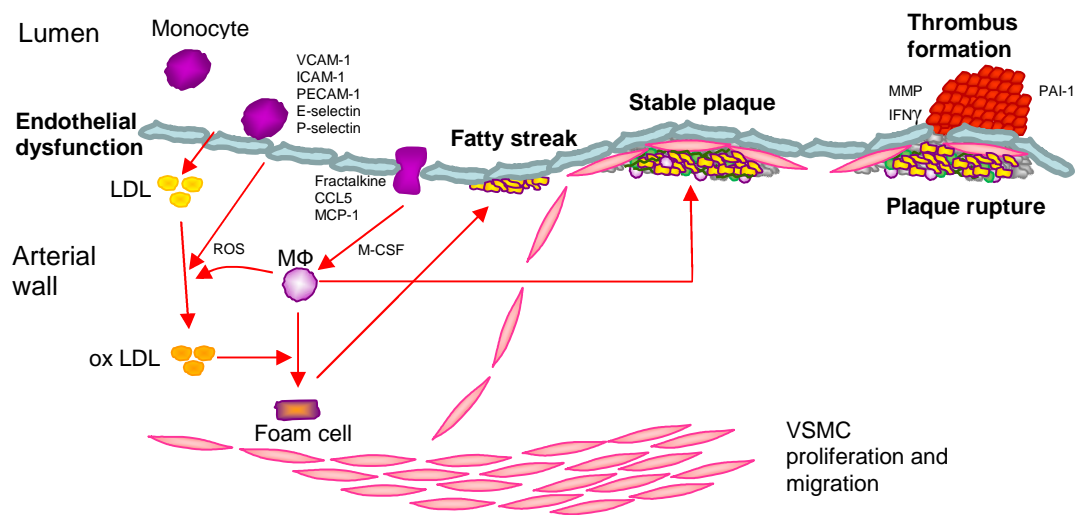

Figure 1 - An overview of the development of atherosclerosis.

CCL5 - Regulated on Activated Normal T-cell expressed and Secreted, ICAM-1 - Intercellular adhesion molecule-1, $\text{IFN}\gamma$ - Interferon γ , $\text{M}\Phi$ - Macrophage, MCP-1 - Monocyte chemoattractant protein-1, M-CSF - Macrophage-colony stimulating factor, MMP - Matrix metalloproteinase, ox LDL - Oxidised low density lipoprotein, PAI-1 - Plasminogen activator inhibitor-1, PECAM-1 - Platelet-endothelial cell adhesion molecule-1, ROS - Reactive oxygen species, VCAM-1 - Vascular cell adhesion molecule-1, VSMC - Vascular smooth muscle cell

The atherosclerotic lesion contains cytokines that convert CD4^+ helper T cells to a type 1 pro-inflammatory helper T cell (Th1) phenotype (Frostegord *et al.*, 1999). These cells secrete a variety of pro-inflammatory mediators including interferon ($\text{IFN}\gamma$), which (amongst other actions) activate macrophages and endothelial cells. Production of macrophage-colony stimulating factor (M-CSF), by activated endothelial cells, induces monocytes, present in the intima, to differentiate into macrophages, which uptake oxidised LDL to form lipid rich foam cells, initiating the formation of a fatty streak (Ross, 1999; Libby, 2002). This fatty streak develops into a stable atherosclerotic plaque, consisting of a lipid core and a fibrous cap composed of

smooth muscle cells and collagen. Immune cells and platelets release growth factors, such as IFN γ and platelet derived growth factor (PDGF), to promote VSMC hyperplasia and migration. Foam cells secrete matrix metalloproteinases, which degrade the fibrous cap, and IFN γ , which inhibits the ability of smooth muscle cells to synthesise collagen, rendering the plaque unstable and vulnerable to rupture (Ross, 1999; Libby, 2002). Following plaque rupture, activated platelets initiate the coagulation cascade resulting in the formation of a thrombus, which can occlude the vessel and impede blood flow, leading to ischaemia (Figure 1).

1.1.3 Restenosis

Arteries that become narrowed by an atherosclerotic plaque can be unblocked by a procedure known as balloon angioplasty. This procedure involves inserting a catheter, with a balloon attached, into the affected artery and then inflating the balloon to crush the plaque, thereby increasing the luminal diameter and blood flow (Figure 2). This process was conducted routinely in the 1990's, but up to 55 % of patients exhibited restenosis, a gradual re-narrowing of the blood vessel, within 6 months (Fischman *et al.*, 1994; Savage *et al.*, 1998). Due to the high incidence of restenosis, many patients now undergo percutaneous coronary intervention (PCI), which involves inserting a wire metal mesh, termed a stent, a scaffold upon which new tissue can grow and also helps maintain an open artery (Figure 2). However, balloon angioplasty followed by stent implantation still results in approximately 25 % of patients exhibiting restenosis (Fischman *et al.*, 1994; Serruys *et al.*, 1994).

The reason for this re-occlusion of inflamed arteries is that angioplasty immediately stimulates an increase in cell adhesion molecule expression and circulating activated monocytes (Serrano *et al.*, 1997), which facilitates the binding of monocytes to the endothelium and their subsequent migration into the subendothelial space. Akin to atherosclerosis, MCP-1 seems to play a key role in the development of restenosis (Furukawa *et al.*, 1999; Cipollone *et al.*, 2001), by promoting transmigration of circulating monocytes into the arterial wall. Recruitment of activated leukocytes into the arterial wall stimulates vascular smooth muscle cell (VSMC) migration from the medial layer of the arterial wall, past the internal elastic lamina, into the intimal or subendothelial space. Leukocytes also promote VSMC proliferation (Ross,

1999;Libby, 2002) leading to neointimal hyperplasia, thereby narrowing the luminal diameter and ultimately restricting blood flow.

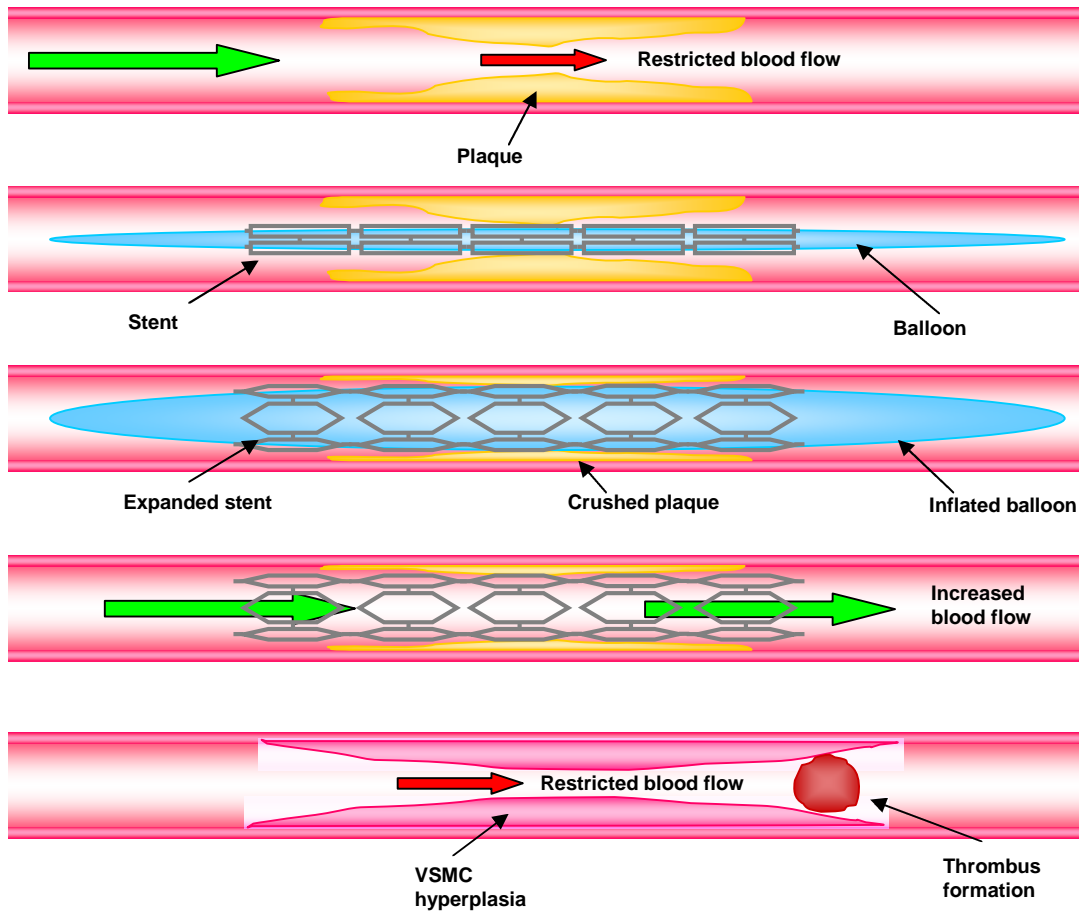

Figure 2 - Balloon angioplasty, stent deployment and restenosis

VSMC - Vascular smooth muscle cell

Due to the high incidence of restenosis, even with the advent of bare metal stents (BMS), drug eluting stents (DES) were designed to release pharmacological agents following implantation, to reduce VSMC proliferation and migration and prevent leukocyte and platelet adhesion/activation. DES have proven to be very successful in reducing the incidence of restenosis; 5 years post implantation 10 % of patients exhibit restenosis (Morice *et al.*, 2007). Although the use of DES has improved the picture, it is complicated by the development of stent thrombosis. This is likely to be caused by endothelial denudation during the procedure, leaving a thrombogenic surface exposed. Regeneration of the endothelium is crucial in restoring an anti-

thrombotic surface. First generation DES release rapamycin (sirolimus) or paclitaxel, in order to inhibit VSMC proliferation and migration; both compounds are macrolide antibiotics that have potent immunosuppressive and anti-inflammatory properties (Schwartz and Vaitkus, 2003). However, these compounds are not selective for smooth muscle cells and it has been shown that rapamycin also inhibits endothelial cell proliferation and migration *in vitro* (Matter *et al.*, 2006), which is a significant drawback since it promotes thrombus formation.

The rate of incidence of stent thrombosis is approximately 0.5 % (Moreno *et al.*, 2005); this appears to be insignificant but when put into context that there were 28,000 coronary stents implanted in the UK in 2000 (British Heart Foundation, 2008a) that equates to approximately 140 patients suffering a life threatening thrombotic event. Patients treated with DES compared to BMS exhibit a higher incidence of MI, partly owing to late thrombotic events (Pfisterer *et al.*, 2006). In order to reduce thrombotic events administration of low dose aspirin (a cyclooxygenase (COX)-1 and -2 inhibitor), clopidogrel (a P2Y₁₂ antagonist), and GpIIb/IIIa antagonists (such as abciximab), is recommended for patients who have undergone stent implantation (King III *et al.*, 2008). However, the significant rates of restenosis and thrombotic events show there remains a clear unmet clinical need and that pharmacological interventions that promote endothelial cell growth but inhibit VSMC proliferation may prove pivotal in advancing the treatment of restenosis in addition to atherogenesis.

1.2 Endothelial function

In accord with the location of the endothelium, it is the major regulator of vascular homeostasis maintaining a balance of vascular tone, smooth muscle cell proliferation, leukocyte activation, thrombogenesis and fibrinolysis. The normal healthy endothelium maintains an anti-inflammatory, anti-coagulant, anti-platelet and fibrinolytic state. This is achieved via the release of various vasodilator and vasoconstrictor mediators of which nitric oxide (NO) has been shown to be vital (Moncada and Higgs, 1993). Endothelial dysfunction, a key trigger for the pathogenesis of atherosclerosis and other CVD, predisposes the vasculature to vasoconstriction, leukocyte adherence, smooth muscle cell proliferation, platelet activation and thrombosis (Davignon and Ganz, 2004).

1.2.1 Nitric Oxide

NO, identified as an endothelium-derived relaxing factor (Palmer *et al.*, 1987; Ignarro *et al.*, 1987), plays a crucial role in the maintenance of vascular tone and reactivity (Moncada and Higgs, 1993). NO is synthesised from L-arginine by an enzyme termed NO synthase (NOS), of which there are 3 isoforms. Endothelial NOS (eNOS) and neuronal NOS (nNOS) are constitutively expressed, whilst inducible NOS (iNOS) is up-regulated in response to pro-inflammatory stimuli such as lipopolysaccharide (LPS). eNOS is the isoform involved in the context of vascular homeostasis as it is predominantly expressed in the endothelium (Pollock *et al.*, 1991) where it synthesises NO to reduce vascular smooth muscle tone, inhibit VSMC proliferation and inhibit leukocyte and platelet activation. eNOS is also expressed in VSMC, red blood cells, bone-marrow derived macrophages, epithelial cells, kupffer cells and epithelial cells (Tracey *et al.*, 1994; Teng *et al.*, 1998; Leifeld *et al.*, 2002; Connelly *et al.*, 2005; Liang *et al.*, 2006; Kleinbongard *et al.*, 2006). NO diffuses from the endothelium to the underlying vascular smooth muscle where it activates soluble guanylyl cyclase (sGC) which catalyses the conversion of guanosine-5'-triphosphate (GTP) to cyclic guanosine-3',5'-monophosphate (cGMP). The level of cGMP is controlled by the activity of a group of enzymes termed cyclic nucleotide phosphodiesterases (PDE). PDE transform cyclic nucleotides (i.e. cGMP and cyclic adenosine-3',5'- monophosphate (cAMP)) into inactive nucleotide monophosphates. cGMP exerts its biological effects by coupling to one of three groups of proteins: cGMP-regulated ion channels, cGMP-binding phosphodiesterases and cGMP-dependent protein kinase (cGK), also known as protein kinase G. In the cardiovascular system, it is through the action of cGK, that cGMP regulates vascular tone.

NO induces smooth muscle relaxation by reducing intracellular $[Ca^{2+}]$ ($[Ca^{2+}]_i$) and by reducing the Ca^{2+} sensitivity of the contractile machinery, through a variety of pathways (Figure 3). cGK phosphorylates and opens large conductance calcium-activated K^+ (BK_{Ca}) channels which hyperpolarises the cell membrane and reduces Ca^{2+} influx through L-type calcium channels (Fukao *et al.*, 1999; Hofmann *et al.*, 2000). Ca^{2+} /ATPase pump located on the plasma membrane and sarcoplasmic reticulum extrudes Ca^{2+} from the cytosol into the extracellular space and the sarcoplasmic reticulum, respectively. Ca^{2+} /ATPase pump has been shown to be

activated by cGMP, most likely through cGK, leading to a reduction in $[Ca^{2+}]_i$ (Furukawa *et al.*, 1988; Clapp and Gurney, 1991). cGK phosphorylates IP₃ receptor, reducing channel activity in response to IP₃ leading to a reduction in $[Ca^{2+}]_i$ (Komalavilas and Lincoln, 1996). In addition, the cGMP-cGK pathway augments myosin light chain phosphatase (MLCP) activity with no affect on MLC kinase activity (Wu *et al.*, 1996). In summary, NO reduces $[Ca^{2+}]_i$, via various cGK-dependent mechanisms, and promotes MLCP activity resulting in smooth muscle relaxation (Figure 3).

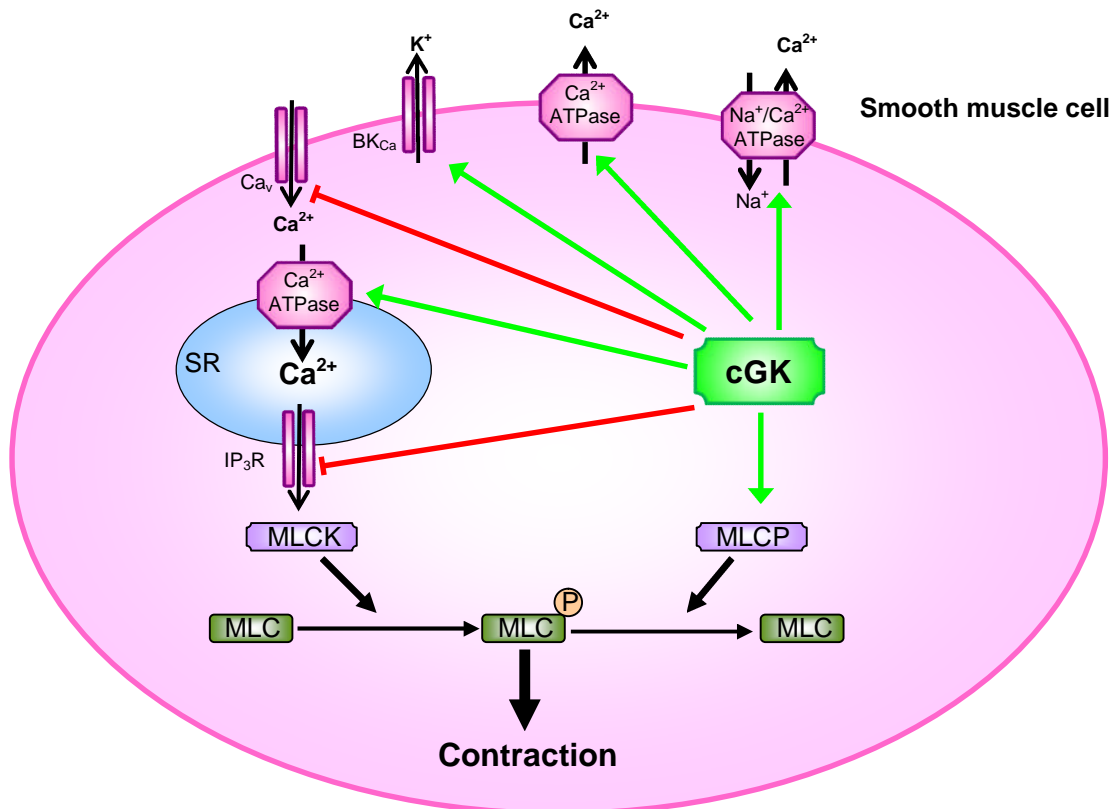

Figure 3 - cGK-mediated smooth muscle relaxation

BK_{Ca} - Large conductance calcium-activated K⁺ channel, Ca_v - Voltage-dependent L-type calcium channel, cGK - cGMP-dependent protein kinase, IP₃R - Inositol 1,4,5-triphosphate receptor, MLC - Myosin light chain, MLCK - MLC kinase, MLCP - MLC phosphatase, SR - Sarcoplasmic reticulum

1.2.2 Prostacyclin

In addition to NO, the endothelium-derived vasodilator prostacyclin (PGI₂) also helps maintain an anti-inflammatory, anti-platelet and anti-mitogenic state. PGI₂ elicits vasodilatation by activating prostacyclin (IP) receptors which are coupled to adenylyl

cyclase which catalyses the conversion of adenosine-5'-triphosphate (ATP) to cAMP leading to activation of cAMP-dependent protein kinase (PKA). PKA, similar to cGK, reduces $[Ca^{2+}]_i$ and the Ca^{2+} sensitivity of the contractile machinery (Abe and Karaki, 1992).

Cyclooxygenase (COX), of which there are two isoforms, COX-1 and -2, converts arachidonic acid to prostaglandin H_2 , (the precursor to prostaglandins and thromboxanes), which is then converted by prostacyclin synthase to yield PGI_2 . COX-1 is constitutively expressed in nearly all cell types whilst COX-2 expression is induced following pro-inflammatory stimuli (Vane *et al.*, 1998). It has been suggested that COX-2 may be constitutively present in endothelial cells, and this may account for the increase of cardiovascular events, with COX-2 inhibitors, although much controversy exists with this hypothesis (Warner and Mitchell, 2008).

1.2.3 Endothelium-derived hyperpolarising factor

Endothelium-derived hyperpolarising factor (EDHF) is a third, unidentified factor that is released from endothelial cells causing smooth muscle cell hyperpolarisation and subsequent relaxation, which is NO- and PGI_2 -independent. EDHF has been shown to be particularly important in the resistance vasculature, where it is the predominant endothelium-derived vasodilator (Shimokawa *et al.*, 1996; Brandes *et al.*, 2000), hence it is crucial in regulating peripheral vascular resistance and blood pressure. The identity of EDHF remains elusive although numerous candidates have been suggested including potassium ions, cytochrome P450 products, hydrogen peroxide and recently C-type natriuretic peptide (CNP; Feletou and Vanhoutte, 2009; Luksha *et al.*, 2009). There are currently two general pathways that are hypothesised to explain EDHF-mediated relaxation. Firstly, an endothelium-derived diffusible factor passes through the internal elastic lamina and reaches the underlying VSMC at a sufficient concentration to activate inwardly rectifying K^+ channels and a Na^+/K^+ ATPase to initiate VSMC hyperpolarisation and relaxation. Secondly, endothelial hyperpolarisation spreads to the VSMC through intercellular gap junctions prompting VSMC hyperpolarisation and relaxation (Luksha *et al.*, 2009). The importance of EDHF in vascular homeostasis has been demonstrated using an eNOS/COX-1 double knockout (KO) mouse model, which permitted the study of the

role of EDHF *in vivo* in animals that can not synthesise NO or PGI₂ (Scotland *et al.*, 2005c). Interestingly female double KO mice are not hypertensive, indicating female mice rely heavily upon EDHF to regulate blood pressure, whereas male double KO mice are hypertensive, demonstrating that males have less dependence upon EDHF to regulate blood pressure. Indeed, male eNOS KO are hypertensive suggesting that males depend largely upon NO as a regulator of blood pressure (Scotland *et al.*, 2005c).

1.2.4 Endothelin-1

To balance the biological activity of endothelium-derived vasodilators, endothelial cells also release vasoconstrictors to increase vascular tone, VSMC proliferation, leukocyte adhesion, endothelial permeability and platelet aggregation. Endothelin (ET)-1, a principal endothelium-derived vasoconstrictor, is synthesised from a prohormone termed prepro-ET-1. This is cleaved to form a 39 amino acid peptide, big ET-1, which is subsequently converted into mature ET-1 by endothelin converting enzyme, found on the membrane of endothelial cells (Bohm and Pernow, 2007). ET-1 acts via two receptors, ET_A primarily located on VSMC leading to vasoconstriction and ET_B, primarily located on endothelial cells but also found on VSMC. Activation of ET_B on endothelial cells releases NO whilst on VSMC results in vasoconstriction (Bohm and Pernow, 2007). Under physiological conditions ET_A-mediated vasoconstriction is partly counteracted by ET_B-mediated NO release from the endothelium. ET-1 causes vasoconstriction by increasing [Ca²⁺]_i, via G_q coupling (Neylon, 1999) and Ca²⁺ sensitisation of the contractile apparatus, via Rho kinase (Miao *et al.*, 2002).

1.3 Natriuretic peptides

Natriuretic peptides are a family of highly conserved hormones which are important in regulating vascular tone and fluid and electrolyte balance (Levin *et al.*, 1998; Baxter, 2004). The principle family members in mammals are atrial natriuretic peptide (ANP), brain natriuretic peptide (BNP) and CNP. ANP and BNP are released from cardiac tissue and act in an endocrine manner to regulate natriuresis, diuresis, blood pressure and cardiac morphology. CNP is found within the vascular system, most notably in

the endothelium, where it acts in a paracrine fashion to regulate endothelial and smooth muscle growth with additional vasodilator and anti-inflammatory effects, possibly as an EDHF (Ahluwalia and Hobbs, 2005;Scotland *et al.*, 2005a).

1.3.1 Discovery

Approximately 30 years ago de Bold and coworkers demonstrated that atrial extracts induce a large diuretic and natriuretic response in the rat (de Bold *et al.*, 1981). This seminal observation led to the isolation of a peptide termed ANP. A few years later a structurally similar, but distinct peptide with analogous natriuretic and diuretic properties was isolated from porcine brain tissue, termed BNP (Sudoh *et al.*, 1988). Although originally discovered in the brain, it is now well recognised the predominant source of BNP is cardiac tissue. Two years later Sudoh and coworkers isolated an additional peptide from porcine brain termed CNP (Sudoh *et al.*, 1990), although it has subsequently shown to be widely distributed throughout the cardiovascular system (Stingo *et al.*, 1992). Since the discovery of the natriuretic peptides there has been great interest in their physiological and patho-physiological roles and their potential in the treatment of CVD.

1.3.2 Structure and synthesis

All natriuretic peptides are produced as prohormones that are cleaved to generate prohormones which are subsequently proteolytically processed to yield the mature active peptide. Each member of the family possess a 17 amino acid ring structure, formed by a disulphide linkage, which is vital for receptor binding (Lee and Burnett, 2007). Within the cyclic structure 11 amino acids are conserved (Figure 4). ANP and BNP, but not CNP, possess amino and carboxyl terminal extensions (Ogawa *et al.*, 1994), which are thought to be important in determining receptor selectivity.

1.3.3 Atrial natriuretic peptide

The human ANP gene (*Nppa*; located on chromosome 1) contains three exons and two introns and following translation a 151 amino acid is synthesised. Cleavage of the amino terminal signal sequence results in the formation of a 126 amino acid peptide, pro-ANP, which is the predominant form stored in granules within the atria

(Vuolteenaho *et al.*, 1985). Corin, a cardiac serine protease, cleaves pro-ANP into a 28 amino acid fragment, the mature form of ANP, and a 98 amino acid fragment (Yan *et al.*, 2000). ANP is released from the atria of the heart in response to stretch stimulation, induced by hypervolaemia. ANP promotes natriuresis (de Bold *et al.*, 1981), vasodilatation (Currie *et al.*, 1983) and inhibition of renin (Burnett *et al.*, 1984) and aldosterone (Atarashi *et al.*, 1984) synthesis in the kidney and adrenal gland, respectively, leading to a reduction in blood volume and hence blood pressure. In addition, ANP reduces secretion of vasopressin from the hypothalamus (Samson *et al.*, 1987) indicating it also has neuromodulatory actions. ANP also prevents cardiac hypertrophy with a minimal effect on cardiac fibrosis, as demonstrated by gene KO mice (Oliver *et al.*, 1997;Mori *et al.*, 2004;Franco *et al.*, 2004).

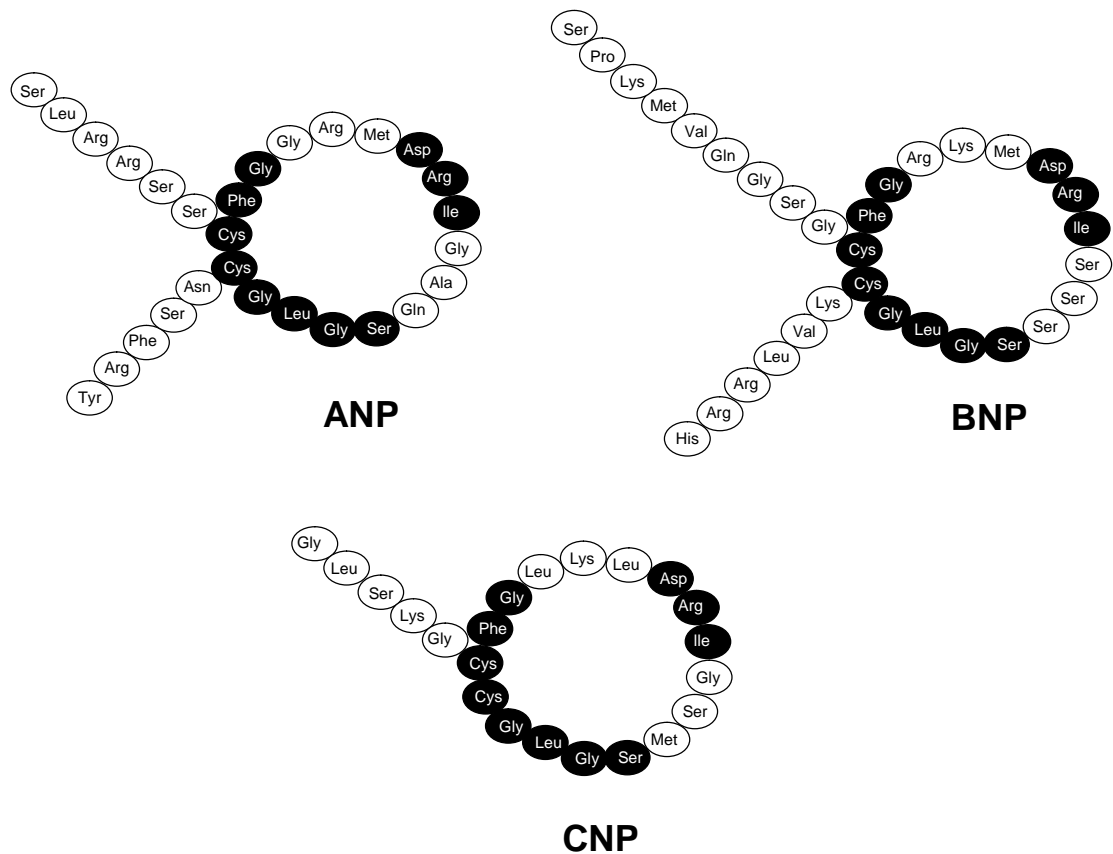

Figure 4 - A schematic showing the primary structure of the natriuretic peptides.
Conserved amino acids are shaded black.

1.3.4 Brain natriuretic peptide

Despite the discovery of BNP in porcine brain tissue (Sudoh *et al.*, 1988), this peptide is mainly synthesised and secreted from cardiac tissue, predominantly the ventricles (Mukoyama *et al.*, 1991). The human BNP gene (*Nppb*; located on chromosome 1) consists of two exons and one intron, encodes a 134 amino acid peptide containing a signal sequence that is cleaved to yield a 108 amino acid peptide, termed pro-BNP, which in turn is cleaved to form mature BNP (32 amino acids; Kone 2001). BNP is released from the ventricles of the heart, in response to stretch stimulation and exerts similar haemodynamic effects to ANP. Since both peptides act at the same receptor, (discussed in section 1.3.7), it is interesting that BNP KO mice exhibit marked cardiac fibrosis, rather than hypertrophy (Tamura *et al.*, 2000), highlighting a distinction between ANP and BNP bioactivity.

1.3.5 C-type natriuretic peptide

CNP is the most highly conserved natriuretic peptide and exhibits 100 % homology in mammals (Koller and Goeddel, 1992). In addition, there is evidence to suggest that CNP is the ancestral precursor from which ANP and BNP evolved (Inoue *et al.*, 2003). The human CNP gene (*Nppc*; located on chromosome 2) contains two exons and one intron (Ogawa *et al.*, 1992). Upon translation CNP is synthesised as a 126 amino acid precursor termed prepro-CNP (Ogawa *et al.*, 1992), which is then cleaved by a signal peptidase to form the 103 amino acid pro-CNP, the form in which CNP is stored. Pro-CNP is cleaved by furin (Wu *et al.*, 2003), a proprotein convertase that is resident in the trans-Golgi network (Thomas, 2002), to yield CNP-53. This peptide is then subsequently cleaved, by an unknown mechanism, to yield the biologically active 22 amino acid form of CNP, CNP-22. In human endothelial cells, hypothalamus, medulla and pons the predominant form is CNP-53 whilst in human plasma it is CNP-22 (Minamino *et al.*, 1991; Stingo *et al.*, 1992). CNP-53 may also exert biological functions as it has been shown to increase cGMP production in cultured mouse astrocytes (Yeung *et al.*, 1996).

CNP KO mice exhibit impaired endochondral ossification, a process associated with fetal bone growth, leading to severe dwarfism (Komatsu *et al.*, 2002). More than 50 %

of the animals die before the age of 4 weeks with less than 30 % surviving more than 16 weeks (Komatsu *et al.*, 2002). This observation demonstrates CNP has a key role in bone growth and healthy development. Unlike ANP and BNP KO mouse models, the cardiovascular role(s) of CNP has not been investigated using a transgenic due to the gross deformation and severe mortality rate.

1.3.6 Urodilatin and dendroaspis natriuretic peptide

Two less well characterised natriuretic peptides have also been identified, urodilatin and dendroaspis natriuretic peptide (DNP). Urodilatin, originally isolated from human urine (Schulz-Knappe *et al.*, 1988), is identical to ANP except for 4 additional amino acids at the N-terminus. DNP was originally identified in the venom of the green mamba snake (*Dendroaspis angusticeps*; Schweitz *et al.*, 1992). Both peptides possess natriuretic and diuretic properties (Lisy *et al.*, 1999) in addition to vasorelaxant actions (Schweitz *et al.*, 1992;Forssmann *et al.*, 2001). DNP immunoreactivity has been found in normal human plasma and atrial myocardium, with increased plasma DNP immunoreactivity in patients with congestive heart failure (Schirger *et al.*, 1999), suggesting it may have a role in human cardiovascular physiology and pathology.

1.3.7 Natriuretic peptide receptors

The natriuretic peptide family exert their biological effects through a family of cell surface proteins termed natriuretic peptide receptors (NPR). The three principal natriuretic peptides bind to all NPR, albeit with differing affinities (Table 1). The rank order of binding affinity for NPR-A is ANP > BNP >> CNP, for NPR-B is CNP >> ANP > BNP and for NPR-C is ANP > CNP > BNP (Bennett *et al.*, 1991;Suga *et al.*, 1992a). CNP has a very low affinity for NPR-A and a high affinity for NPR-B, hence CNP is regarded as the sole endogenous ligand for NPR-B; ANP and BNP are the physiological ligands for NPR-A.

NPR-A and NPR-B are particulate guanylyl cyclase (pGC) linked receptors and are also referred to as GC-A and GC-B, respectively (Figure 5). Both are composed of an extracellular ligand binding domain, a small hinge region, a kinase homology domain and an intracellular guanylyl cyclase domain. Binding of natriuretic peptides to these

receptors catalyses the conversion of GTP to the second messenger, cGMP. NPR-C possesses an extracellular ligand binding domain which shares approximately 30 % homology with NPR-A and NPR-B, but in contrast NPR-C lacks an intracellular kinase homology and guanylyl cyclase domain (Figure 5). Instead, NPR-C possesses a 37 amino acid intracellular tail that has been shown to be a *Pertussis toxin* (PTx) sensitive G_i binding domain (Murthy *et al.*, 1998).

	NPR-A	NPR-B	NPR-C
ANP	1.9 pM	5.4 nM	2.6 pM
BNP	7.3 pM	30 nM	13 pM
CNP	>500 nM	7 pM	10.8 pM

Table 1 - Dissociation constants (K_d) for binding of human natriuretic peptides to human natriuretic peptide receptors.

Values determined from experiments using the extracellular domain of each receptor fused to the constant domain of IgG (Bennett *et al.*, 1991).

1.3.7.1 Natriuretic peptide receptor-A

NPR-A is a 1061 amino acid protein that is expressed in larger conduit vessels, kidney and adrenal glands (Levin *et al.*, 1998). Activation of NPR-A by ANP or BNP promotes vasorelaxation, natriuresis, decreases renin and aldosterone synthesis (Potter *et al.*, 2006) and also has anti-mitogenic effects on smooth muscle cells (Hutchinson *et al.*, 1997). NPR-A KO mice exhibit raised blood pressure, cardiac hypertrophy and interstitial fibrosis (Oliver *et al.*, 1997), demonstrating the importance of this receptor in regulating blood pressure and cardiac morphology.

1.3.7.2 Natriuretic peptide receptor-B

NPR-B is a 1047 amino acid protein that shares 44 % homology in the extracellular ligand binding domain with NPR-A (Chinkers *et al.*, 1989;Lowe *et al.*, 1989). NPR-B is highly expressed in the brain, including the pituitary gland, and so may have a role

in neuroendocrine regulation (Kone, 2001). NPR-B has also been shown to be expressed in blood vessels (Suga *et al.*, 1992c), although NPR-B KO mice do not show any significant change in blood pressure compared to wild type (WT; Tamura *et al.*, 2004). NPR-B KO mice suffer from reduced weight and dwarfism due to impairment of endochondral ossification and a reduction of longitudinal vertebra and limb-bone growth (Tamura *et al.*, 2004), confirming a role for CNP in osteoclast/osteoblast function and bone metabolism.

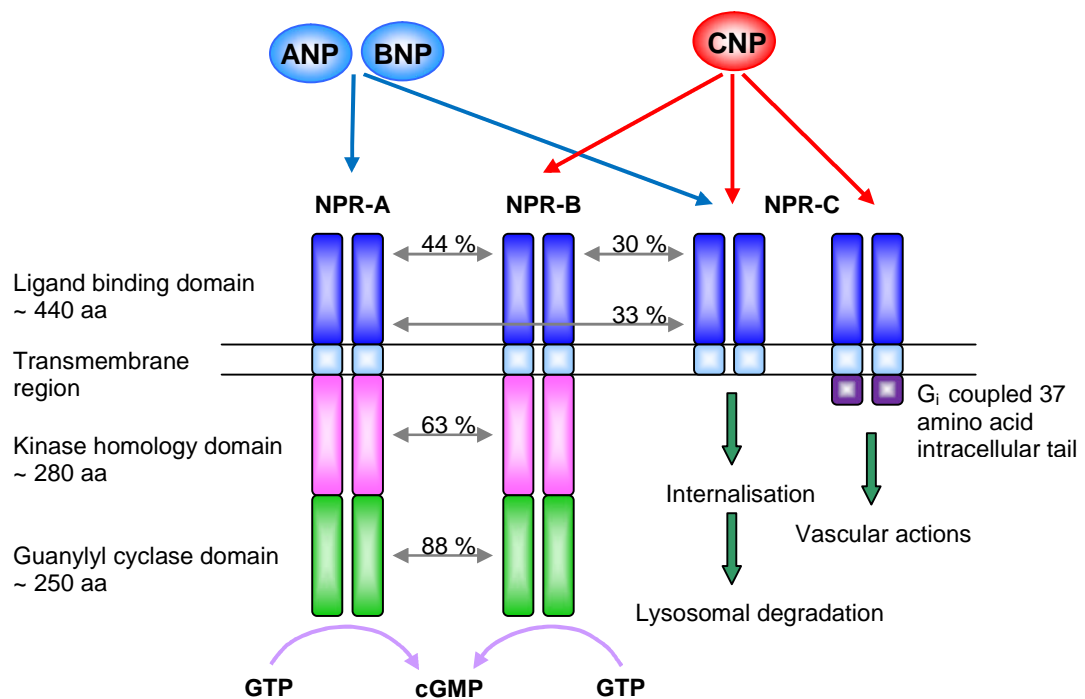

Figure 5 - Structure and homology of the natriuretic peptide receptors

ANP - Atrial natriuretic peptide, BNP - Brain natriuretic peptide, CNP - C-type natriuretic peptide, GTP - guanosine-5'-triphosphate, cGMP - cyclic guanosine-3',5'-monophosphate, G_i - inhibitory G protein, NPR - Natriuretic peptide receptor

1.3.7.3 Natriuretic peptide receptor-C

NPR-C is a 540 amino acid protein, widely distributed throughout the body including brain, kidney, and VSMC and comprises more than 95% of the total NPR population in vascular cells (Maack, 1992; Anand-Srivastava, 2005). NPR-C is constitutively present in the cell membrane as a homodimer of 120 KDa (Maack, 1992). Due to its

lack of guanylyl cyclase functionality and intrinsic kinase domain, NPR-C has long been thought to solely act as a clearance receptor (discussed in section 1.3.8; Maack *et al.*, 1987). In NPR-C KO mice the half life of ANP is extended (1.44 ± 0.05 min and 2.40 ± 0.08 min, in WT and NPR-C KO, respectively) and these animals are mildly hypotensive, although the plasma concentrations of ANP or BNP are unchanged (Matsukawa *et al.*, 1999). These animals also exhibit increased bone turnover resulting in hunched backs, dome shaped skulls, elongated tails, elongated femurs, tibiae, metatarsal and digital bones (Matsukawa *et al.*, 1999). These observations, coupled with evidence showing NPR-C possesses a G_i -dependent *Pertussis toxin* sensitive domain that is able to inhibit adenylate cyclase (Pagano and Anand-Srivastava, 2001) and activate phospholipase C- β 3 (Murthy *et al.*, 2000), strongly suggests a signalling role for this receptor.

1.3.8 Clearance of natriuretic peptides

Plasma levels of natriuretic peptides are controlled by the rate of synthesis and release and removal from the circulation via two discrete mechanisms. One pathway involves NPR-C mediated endocytosis and the other is hydrolysis by neutral endopeptidase 24.11 (enkephalinase), a zinc metallopeptidase (Valli *et al.*, 1999). Following endocytosis, lysosomal degradation of the peptide occurs and the internalised receptor is rapidly recycled to the surface (Cohen *et al.*, 1996). NPR-C contains a single tyrosine (Tyr⁵⁰⁸) amino acid in the cytoplasmic domain that has been shown to be important in clathrin coated pit endocytosis of this receptor, however NPR-C does not contain any recognised internalisation motifs in the cytoplasmic domain (Cohen *et al.*, 1996).

Neutral endopeptidase is widely distributed throughout the body including kidney, lung, heart (Erdos and Skidgel, 1989) and expressed on the surface of human endothelial cells (Graf *et al.*, 1995), smooth muscle cells, cardiac myocytes and fibroblasts (Vanderheyden *et al.*, 2004). It metabolises ANP (Stephenson and Kenny, 1987), BNP, CNP (Kenny *et al.*, 1993) and numerous other bioactive peptides including bradykinin, angiotensin (Ang) II, enkephalin and ET-1 (Erdos and Skidgel, 1989; Fagny *et al.*, 1991). Under physiological conditions it is believed that neutral endopeptidase has a minor role to play in the inactivation of natriuretic peptides;

however in pathophysiological conditions in which there are raised levels of natriuretic peptides, and a large proportion of NPR-C are occupied, neutral endopeptidase may play a more substantial role in clearance (Maack, 1992; Okolicany *et al.*, 1992). This is exemplified by the work of Olins *et al.* who showed thiorphan, a specific neutral endopeptidase 24.11 inhibitor, has no effect on endogenous ANP levels but increases plasma ANP concentration in rats administered with exogenous ANP (Olins *et al.*, 1989).

1.4 Cardiovascular roles of CNP

1.4.1 Expression and distribution

The widespread distribution of CNP in the cardiovascular system, particularly endothelial cells (Stingo *et al.*, 1992), intimates it has a role in vascular homeostasis. CNP is thought to act in a paracrine/autocrine manner, as opposed to the endocrine actions of ANP and BNP. Under physiological conditions the plasma concentration of CNP is approximately 1 pg/ml (Hama *et al.*, 1994; Igaki *et al.*, 1996; van der Zander *et al.*, 2002; Zambruni *et al.*, 2007) and this value rises in patients with renal failure (3 pg/ml; Igaki *et al.*, 1996) and septic shock (13 pg/ml; Hama *et al.*, 1994). In patients with congestive heart failure, plasma concentration of CNP is not altered but the right atrial concentration of CNP is approximately 2-fold greater (Wei *et al.*, 1993; Kalra *et al.*, 2003; Del Ry *et al.*, 2006). In an animal model, over expression of CNP in cardiomyocytes does not affect ischaemia/reperfusion (I/R) injury infarct size but does reduce the resultant cardiac hypertrophy (Wang *et al.*, 2007).

Similar to NO, arterial physiological shear stress augments endothelial CNP mRNA expression and production in a variety of endothelial cells (Chun *et al.*, 1997). In addition, oxidative stress produces reactive oxygen species (ROS), which cause endothelial dysfunction by reducing NO bioavailability, and in bovine coronary artery endothelial cells (BCAEC) augments CNP secretion (Chun *et al.*, 2000). This observation suggests CNP may compensate for a lack of NO bioavailability, which occurs in CVD.

Growth factors have been shown to differentially modulate CNP secretion from endothelial cells. One of the most potent stimuli for CNP expression and release is transforming growth factor (TGF)- β , a cytokine involved in vascular remodelling, which increases endothelial CNP secretion by approximately 100-fold (Suga *et al.*, 1992b; Doi *et al.*, 1996). Vascular endothelial growth factor (VEGF), a potent endothelial cell mitogen, attenuates CNP secretion from BCAEC, whilst basic fibroblast growth factor (bFGF), another potent endothelial cell mitogen, augments CNP secretion (Doi *et al.*, 1996). The pro-inflammatory mediators interleukin (IL)-1 β , tumour necrosis factor (TNF)- α and LPS (Suga *et al.*, 1993), all of which have important roles in vascular remodelling and inflammatory cardiovascular disease, increase CNP secretion from BCAEC, whilst IL-2, a cytokine that promotes T cell growth, has no effect. These observations demonstrate that pro-inflammatory mediators, which are present in CVD, promote endothelial CNP secretion, possibly as a protective response.

Interestingly, ANP and BNP significantly augment CNP production in bovine aortic endothelial cells (BAEC), an effect blocked by the cGMP-dependent protein kinase inhibitor KT 5823 (Nazario *et al.*, 1995). The NPR-C specific agonist des(Gln¹⁸, Ser¹⁹, Gly²⁰, Leu²¹, Gly²²)-ANP fragment 4-23 (cANF⁴⁻²³) has no effect, suggesting ANP and BNP increase the production of CNP in a cGMP-dependent manner, via NPR-A (Nazario *et al.*, 1995). Indeed, the cGMP and cAMP mimetics, 8-bromo-cGMP and 8-bromo-cAMP, respectively, increase BCAEC CNP secretion (Suga *et al.*, 1992b). In healthy individuals, plasma CNP levels are raised to 7.1 pg/ml following BNP infusion (van der Zander *et al.*, 2002). These observations highlight the ability of ANP and BNP to augment CNP secretion, intimating some of the effects of these peptides may be in part via CNP.

1.4.2 Vasodilatation

CNP is a potent arterial- and venous-dilator of isolated human (Wiley and Davenport, 2001), rat (Drewett *et al.*, 1995), murine (Madhani *et al.*, 2003) and porcine vessels (Barber *et al.*, 1998). In conduit arteries, CNP-induced relaxations are blocked by the selective NPR-A/B antagonist HS-142-1 (Drewett *et al.*, 1995; Wennberg *et al.*, 1999; Madhani *et al.*, 2003), demonstrating that in these vessels, vasodilatation is

NPR-B mediated. However, there is strong evidence to suggest that in resistance arteries the relaxant effect of CNP is attributable to NPR-C activation.

In the rat mesenteric artery CNP and EDHF elicit equivalent hyperpolarisation and relaxation responses that are unaffected by HS-142-1, but mimicked by the selective NPR-C agonist, cANF⁴⁻²³ (Chauhan *et al.*, 2003). Moreover, responses to CNP or acetylcholine (ACh) are blocked by a combination of barium (Ba²⁺), an inwardly rectifying K⁺ (K_{IR}) channel inhibitor, plus ouabain, a Na⁺/K⁺ ATPase inhibitor. Similar findings have been shown in the rat coronary vasculature where CNP or cANF⁴⁻²³ reduces the perfusion pressure in isolated rat heart, an effect that is blocked by Ba²⁺ plus ouabain (Hobbs *et al.*, 2004). This combination of inhibitors is routinely used in the study of EDHF as they block EDHF-mediated hyperpolarisation and relaxation in numerous vessels and species (Busse *et al.*, 2002). Such observations intimate that CNP and EDHF are synonymous. Recently, a definitive role for CNP as an EDHF in rat mesenteric artery has been elucidated with the use of a NPR-C specific antagonist, M372049 (Villar *et al.*, 2007). This study proposed that at least two EDHF pathways exist within the rat mesenteric artery, one which is dependent upon CNP/NPR-C activation and opening of a Ba²⁺-sensitive G-protein coupled inwardly rectifying potassium channel (GIRK), and a second which is triggered by IK_{Ca} activation and dependent upon Na⁺/K⁺ ATPase stimulation (Figure 6).

CNP dilates rat coronary and mesenteric arteries via NPR-C, however, ANP is unable to dilate small resistance arteries through NPR-C activation, even though ANP binds to the receptor (Madhani *et al.*, 2003). This observation raises the possibility that either there is more than one subtype of NPR-C (Anand-Srivastava, 2005) or that CNP interacts differently with NPR-C to cause signal transduction and receptor internalisation whilst the other natriuretic peptides can only stimulate receptor internalisation (Scotland *et al.*, 2005a). However, ANP has been shown to inhibit proliferation of rat astroglial and epithelial cells in an NPR-C dependent manner (Levin and Frank, 1991; Gower, Jr. *et al.*, 2006), suggesting all natriuretic peptides have the ability to exert effects via NPR-C.

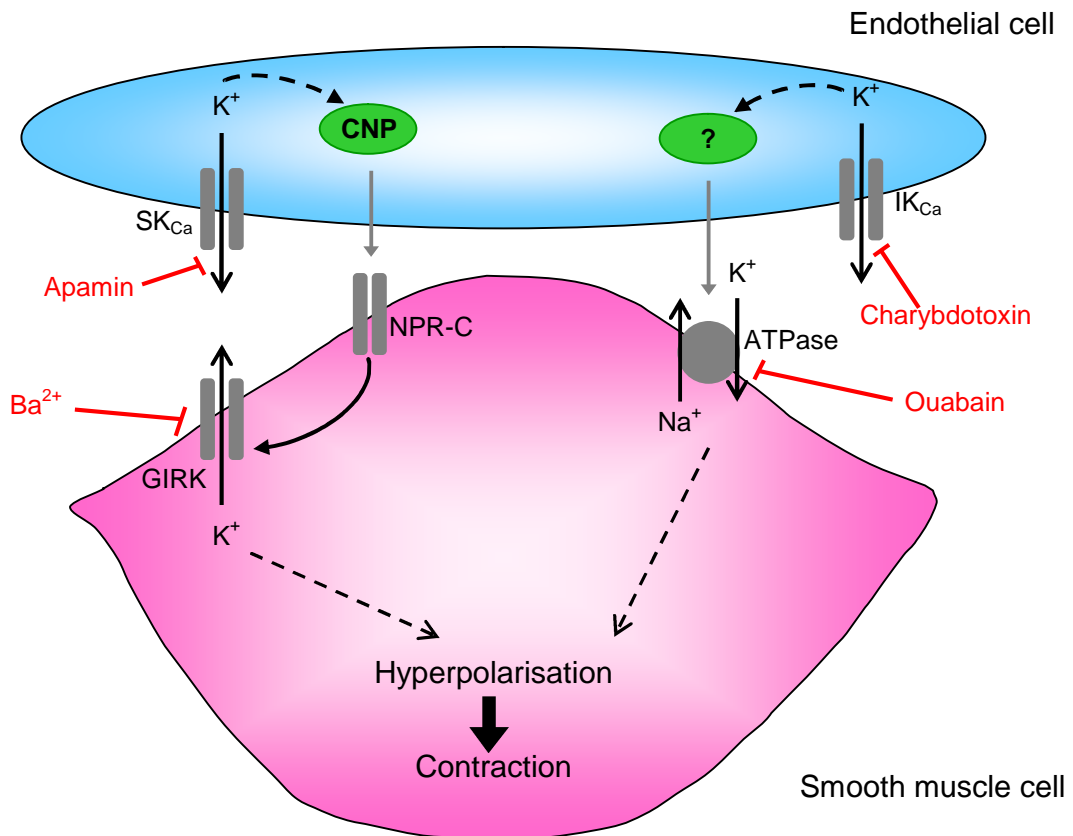

Figure 6 - Proposed EDHF pathways present in rat mesenteric arteries

GIRK - G-protein coupled inwardly rectifying potassium channel, IK_{Ca} - Intermediate conductance calcium channel, SK_{Ca} - Small conductance calcium channel

1.4.3 Blood pressure regulation

Blood pressure is dependent upon cardiac output, the volume of blood pumped by one ventricle per minute, and systemic vascular resistance, the force that must be overcome to push blood through the circulatory system. As described in section 1.4.2 CNP is a potent vasodilator of isolated blood vessels, particularly resistance arteries, which suggests CNP has the ability to affect systemic vascular resistance and hence blood pressure. Indeed, several studies support this thesis; intravenous administration of CNP in healthy volunteers (0.43 nmol/kg), monkeys (10 nmol/kg) and dogs (10 ng/kg/min) causes a transient reduction in blood pressure (Clavell *et al.*, 1993; Igaki *et al.*, 1996; Seymour *et al.*, 1996). Furthermore, CNP administered to rats as a bolus (30 nmol/kg) or continuous (0.1 nmol/kg/minute) dose causes a significant reduction in

blood pressure (Aizawa *et al.*, 2008). These studies reveal that exogenous CNP is able to modulate blood pressure either through its effects on smooth muscle tone or via blood volume regulation. Additionally, a recent study has shown that mice with liver targeted CNP overexpression exhibit an approximate 25 mmHg reduction in systolic blood pressure (Kake *et al.*, 2009), which further supports the hypothesis that CNP is able to regulate blood pressure.

1.4.4 Interaction between CNP and the renin-angiotensin-aldosterone-system

The renin-angiotensin-aldosterone system (RAAS) is a key, well characterised homeostatic mechanism, which regulates blood volume and systemic vascular resistance and hence has a vital role in blood pressure regulation. Renin, an enzyme released from juxtaglomerular cells in the kidney in response to low blood pressure, cleaves angiotensinogen to angiotensin I, which is converted to Ang II by angiotensin converting enzyme, a membrane bound enzyme found on the surface of endothelial cells, particularly pulmonary endothelial cells. Ang II has a wide variety of effects including vasoconstriction, increased sodium retention, aldosterone release, smooth muscle cell proliferation and platelet aggregation (Weir and Dzau, 1999). Aldosterone, produced by the zona glomerulosa of the adrenal cortex, promotes sodium and water reabsorption and hence increases blood pressure.

In humans, CNP administered i.v. has been shown to reduce plasma aldosterone (Hunt *et al.*, 1994; Igaki *et al.*, 1996) but other studies show a minimal effect (Cargill *et al.*, 1995; Barletta *et al.*, 1998). Hunt *et al.* observed a significant reduction in plasma aldosterone, however there was no change in natriuresis (Hunt *et al.*, 1994). Infusion of CNP has been shown to have very little or no effect on natriuresis and diuresis (Hunt *et al.*, 1994; Cargill *et al.*, 1995; Igaki *et al.*, 1996; Barletta *et al.*, 1998) demonstrating that CNP has a very limited or no role in blood volume regulation. These observations suggest that the blood pressure altering effect of CNP is primarily via arterial tone regulation.

1.4.5 Regulation of leukocyte and platelet reactivity

Cell adhesion molecules play a prominent role in the pathogenesis of atherosclerosis and restenosis. Numerous cell adhesion molecules exist to coordinate interaction of circulating cells and the endothelium to recruit cells to sites of inflammatory damage. These are expressed by various cell types, in particular leukocytes, platelets and endothelial cells, mostly in response to cell activation by inflammatory stimuli. An important step in atherogenesis is leukocyte recruitment, a 4 step process consisting of initial tethering and rolling of leukocytes along the endothelium, followed by firm adhesion and subsequent diapedesis. The majority of cell adhesion molecules belong to one of 4 protein families: selectins, immunoglobulins, integrins and cadherins. P-selectin is found on platelets and endothelial cells and is involved in the rolling and tethering of platelets to endothelial cells. L-selectin, expressed by leukocytes, and E-selectin, present on activated endothelial cells, are all involved in rolling and tethering of leukocytes to endothelial cells (Blankenberg *et al.*, 2003). The immunoglobulin family contains ICAM, VCAM-1 and PECAM-1, all of which are involved in firm adhesion of leukocytes to endothelial cells (Blankenberg *et al.*, 2003).

CNP has been shown to inhibit basal, IL-1 β - and histamine-induced leukocyte rolling due to a reduction in P-selectin expression (Scotland *et al.*, 2005b). CNP has also been shown to reduce expression of VCAM-1 and ICAM-1 in rabbit coronary artery following balloon angioplasty (Qian *et al.*, 2002). NPR-C may be involved in mediating these effects as cANF⁴⁻²³ reduces basal leukocyte rolling in eNOS KO mice (Scotland *et al.*, 2005b). However, it is possible NPR-B may also have a role to play as BAY 41-2272, an sGC activator, also reduces basal leukocyte rolling in eNOS KO mice (Ahluwalia *et al.*, 2004), demonstrating cGMP is able to inhibit leukocyte rolling. These data provide an insight into the anti-inflammatory effects of CNP, implying it may be protective in inflammatory CVD.

Currently, very little is known about natriuretic peptides and their effects on platelets. An *in vitro* study has shown CNP to inhibit P-selectin expression and platelet aggregation in thrombin-activated platelets (Scotland *et al.*, 2005b). Furthermore, it has been shown that cGMP levels are unaltered in human platelets when administered with ANP or CNP, suggesting a lack of NPR-A/B on the surface of platelets (Blaise *et*

al., 1996). Radioligand binding studies showed that displacement of ^{125}I -ANP was similar when induced by ANP or cANF⁴⁻²³ intimating that platelets solely express NPR-C (Blaise *et al.*, 1996). Collectively these observations suggest that the effects of CNP on platelets are NPR-C dependent and suggest that CNP may be beneficial in preventing/treating thrombus formation, of which MI and stroke are a consequence.

1.4.6 CNP in atherosclerosis and restenosis

The role of endogenous CNP in the pathophysiology of atherosclerosis is unknown, although the vasodilator, anti-platelet and anti-leukocyte effects I have described above suggest that it is anti-atherogenic. Moreover, there are links between CNP and atherosclerosis/restenosis which argue for an endogenous cytoprotective role for the peptide. For example, CNP has been shown to be present in endothelial cells in normal human coronary arterial segments, however in atherosclerotic lesions endothelial cells express very little or no CNP (Naruko *et al.*, 1996). In contrast, CNP is not present in smooth muscle cells or macrophages in normal human coronary arterial segments, but CNP expression is increased in atherosclerotic lesions in medial and intimal smooth muscle cells and macrophages (Naruko *et al.*, 1996; Casco *et al.*, 2002). CNP mRNA has been shown to be present in early and intermediate atherosclerotic plaques but absent in advanced plaques (Casco *et al.*, 2002). Furthermore, there is increased expression of NPR-B and NPR-C in intermediate to advanced atherosclerotic lesions (Casco *et al.*, 2002), intimating that endogenous CNP has a role in the suppression of atherosclerosis. CNP mRNA, NPR-B and furin, the enzyme responsible for converting pro-CNP to CNP, are down-regulated in stenotic human aortic valves suggesting that endogenous CNP prevents aortic valve calcification (Peltonen *et al.*, 2007).

As mentioned previously, an initiating process in the development of atherosclerosis is infiltration of oxidised LDL into the arterial intima. Oxidised LDL leads to endothelial dysfunction and promotes foam cell formation (Ross, 1999) whilst high density lipoprotein (HDL) is protective against atherosclerosis (Lowenstein and Cameron, 2010). In BCAEC, basal and TGF- β -induced CNP expression is down-regulated by oxidised LDL, whilst HDL alone has no effect (Sugiyama *et al.*, 1995). However, HDL reverses the oxidised LDL reduction in CNP secretion suggesting lipoproteins

are able to modulate endothelial CNP production (Sugiyama *et al.*, 1995). The above observations highlight a possible mechanism by which oxidised LDL exerts its detrimental effects and HDL invokes its beneficial effects.

An immunohistochemical study of patients who had undergone PCI showed CNP and NPR-C expression in neointimal smooth muscle cells, suggesting a role for CNP in the control of neointimal hyperplasia following arterial injury (Naruko *et al.*, 2005). Following balloon angioplasty, CNP promotes re-endothelialisation in rabbit femoral artery (Doi *et al.*, 2001) and carotid artery (Qian *et al.*, 2002) and inhibits neointimal thickening in rat carotid artery (Furuya *et al.*, 1993), rabbit carotid artery (Gaspari *et al.*, 2000; Qian *et al.*, 2002) and rabbit femoral artery (Doi *et al.*, 2001). In addition CNP reduces *in vivo* expression of VCAM-1 and ICAM-1 (Qian *et al.*, 2002) and *in vitro* P-selectin expression (Scotland *et al.*, 2005b). In sum, these observations reveal the ability of CNP to counteract both atherogenesis and restenosis and in conjunction with its anti-inflammatory and blood pressure altering effects suggest it may function as an endogenous, endothelium-derived vasoprotective peptide.

1.4.7 Vascular cell proliferation

The observation that CNP is synthesised and released from endothelial cells and that endothelial cells express all 3 natriuretic peptide receptors (Suga *et al.*, 1992d), suggests that CNP may act in an autocrine manner, to regulate endothelial function. One facet of this profile is the regulation of cell growth. Previous work has shown CNP promotes endothelial cell proliferation. *In vitro*, CNP is pro-mitogenic (Doi *et al.*, 2001; Ohno *et al.*, 2002; Yamahara *et al.*, 2003; Pelisek *et al.*, 2006) and *in vivo* CNP promotes re-endothelialisation in rabbit femoral artery (Doi *et al.*, 2001) and carotid artery (Qian *et al.*, 2002) following balloon angioplasty (described in section 1.1.3). In addition, adenoviral delivery of CNP to rabbit jugular vein grafts induces greater re-endothelialisation in comparison to control vein grafts (Ohno *et al.*, 2002). There is evidence to suggest that CNP mediated endothelial cell proliferation is mediated via NPR-B as cANF⁴⁻²³ has no effect on endothelial cell mitogenesis (Ohno *et al.*, 2002) and also Rp-8-pCPT-cGMP, a cGMP dependent protein kinase inhibitor, inhibits CNP-induced human umbilical vein endothelial cell (HUVEC) capillary network formation (Yamahara *et al.*, 2003).

In contrast to its effects on endothelial cell proliferation, CNP inhibits VSMC proliferation. The first evidence of CNP as a regulator of growth was in cultured rat VSMC, which upon addition of CNP, resulted in DNA synthesis inhibition (Furuya *et al.*, 1991). *In vivo* experiments have shown that CNP inhibits neointimal thickening in rat carotid artery (Furuya *et al.*, 1993), rabbit carotid artery (Gaspari *et al.*, 2000; Qian *et al.*, 2002) and rabbit femoral artery (Doi *et al.*, 2001). The receptor responsible for the anti-proliferative effect of CNP on smooth muscle cells is controversial and evidence exists for NPR-B and NPR-C. Studies have demonstrated CNP-induced inhibition of smooth muscle cell proliferation are concomitant with an increase in cGMP (Furuya *et al.*, 1991; Furuya *et al.*, 1993; Hutchinson *et al.*, 1997; Doi *et al.*, 2001), suggesting the involvement of NPR-B. Contrary to these studies is the work of Cahill *et al* who showed that CNP inhibits growth of aortic smooth muscle cells via NPR-C in a cGMP-independent manner (Cahill and Hassid, 1994). Studies from our lab have also confirmed a role for CNP/NPR-C inhibition of RAoSMC proliferation and have also demonstrated that the pathway involves G_i coupling to NPR-C, which enhances extracellular signal-regulated kinase (ERK 1/2) phosphorylation (Panayiotou, 2007).

The studies outlined above emphasise the unique mitogenic profile of CNP with disparate regulation of endothelial cell and VSMC growth. As previously described (section 1.1.3), agents released from DES inhibit endothelial cell and VSMC mitogenesis, which leads to inadequate healing of the vessel, leaving an exposed thrombogenic surface. CNP promotes endothelial cell proliferation, whilst inhibiting VSMC growth, which is an attractive profile in the context of atherosclerosis and restenosis, as endothelial cell damage and VSMC proliferation are key steps in both vascular diseases. Hence, CNP or pharmacological manipulation of CNP signalling would be ideal targets for the treatment of these conditions. It is important therefore that the NPR subtypes and intracellular pathways underpinning the mitogenic effects of CNP in endothelial cells and VSMC are fully elucidated to optimise potential for therapeutic exploitation.

1.5 Regulation of cell growth

1.5.1 Mitogen-activated protein kinases

Mitogen-activated protein kinases (MAPK) pathways are involved in a diverse variety of actions, including cell proliferation, differentiation, inflammation and embryogenesis (Pearson *et al.*, 2001). Each pathway consists of a cascade of at least three protein kinases activated in series; a MAPK kinase kinase (MKKK), a MAPK kinase (MKK) and a MAPK (Zhang and Liu, 2002). Three principle MAPK pathways have been identified; ERK, p38 and the c-Jun N-terminal kinase/stress-activated protein kinase (JNK/SAPK) pathway (Figure 7).

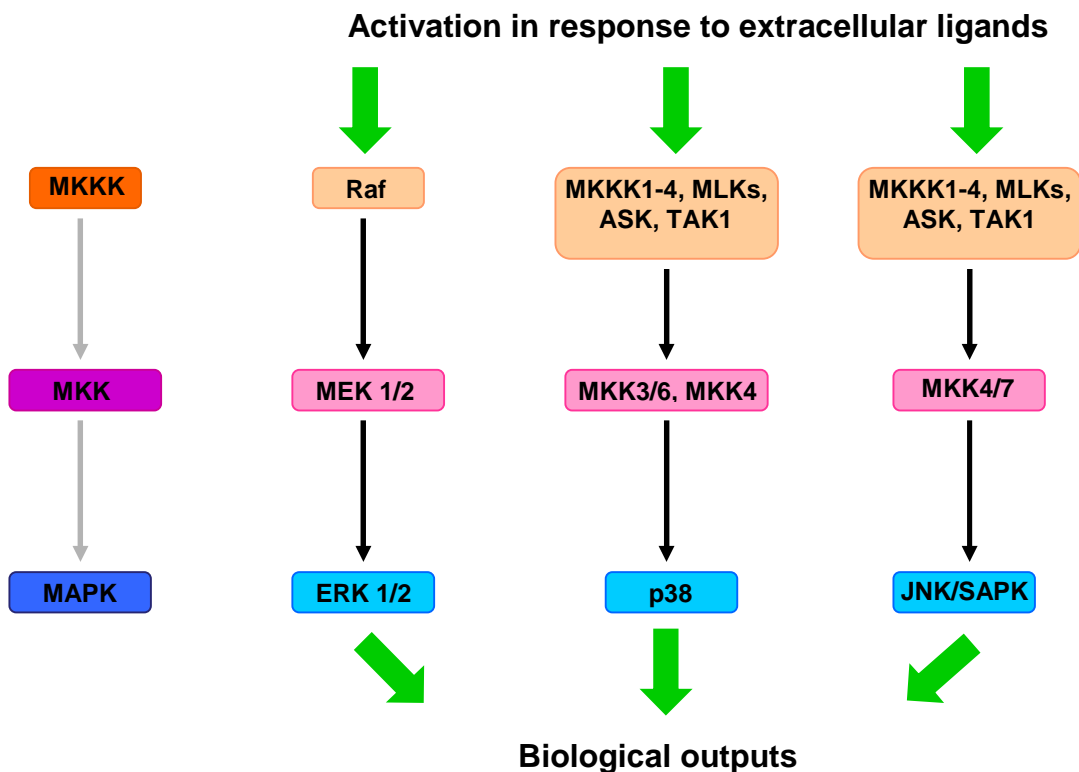

Figure 7 - Principle MAPK pathways

ASK - Apoptosis-signal regulating kinase, ERK 1/2 - Extracellular signal-regulated kinase, JNK/SAPK - c-Jun N-terminal kinase/stress-activated protein kinase, MAPK - Mitogen-activated protein kinase, MKK - MAPK kinase, MEK - MAPK/ERK, MKKK - MAPK kinase kinase, MLK - Mixed lineage kinase, TAK - Transforming growth factor- β -activated protein kinase

1.5.1.1 ERK 1/2

ERK 1/2 (p44/42) are ubiquitously expressed serine/threonine kinases which share 85 % homology (Pearson *et al.*, 2001). They are activated by receptor tyrosine kinases and G protein-coupled receptors and are one of the key signal transduction pathways involved in regulation of the cell cycle. ERK 1/2 are activated by MAPK/ERK (MEK) 1 and 2, which are phosphorylated by Raf isoforms (Zhang and Liu, 2002). ERK 1/2 phosphorylation is required for cell proliferation in mature differentiated eukaryotic cells and acts via multiple mechanisms to promote G1 phase entry of the cell cycle (Meloche and Pouyssegur, 2007; Chambard *et al.*, 2007).

1.5.1.1.1 ERK 1/2 and endothelial cell proliferation

ERK 1/2 signalling is important in endothelial cell proliferation. Endothelial cell growth factors, VEGF, bFGF and epidermal growth factor activate ERK 1/2 resulting in BAEC and HUVEC proliferation (Pedram *et al.*, 1998; Yu and Sato, 1999; Wu *et al.*, 2000). Moreover, endothelial cell ERK 1/2 knockout mice die *in utero* due to reduced angiogenesis and aortic endothelial cells from these mice exhibit decreased proliferation and migration (Srinivasan *et al.*, 2009).

1.5.1.1.2 ERK 1/2 and vascular smooth muscle cell growth

In VSMC the role of ERK1/2 is less clear. In rat aortic smooth muscle cells (RAoSMC), serum-induced proliferation is blocked by PD98059 (Lu *et al.*, 2006), an ERK 1/2 inhibitor, and PD0185625 (Gennaro *et al.*, 2004), a selective MEK inhibitor, suggesting that ERK 1/2 underlies this mitogenesis. This is supported by the observation that rats administered PD0185625 and subjected to carotid artery balloon injury, exhibit reduced neointimal formation (Gennaro *et al.*, 2004). Furthermore, PDGF, Ang II and bradykinin induce RAoSMC growth via ERK 1/2 (Zhan *et al.*, 2003; Yang *et al.*, 2005; Walcher *et al.*, 2006; Chiou *et al.*, 2009). In contrast, however, NO has been shown to inhibit RAoSMC proliferation in a cGMP-independent manner via an up-regulation of ERK 1/2 (Bauer *et al.*, 2001). Conjointly, these observations highlight the ability of ERK 1/2 activation to result in pro- or anti-mitogenic effects dependent upon the stimulus.

1.5.1.2 p38

There are four isoforms of p38 MAPK; α , β , γ and δ of which α and β exhibit 75% homology, whilst γ and δ are more distant relatives. All p38 kinases can be categorised by a Thr-Gly-Tyr dual phosphorylation motif (Zarubin and Han, 2005). The p38 MAPK family is activated by cellular stress signals including LPS, pro-inflammatory cytokines, heat shock, high osmotic stress and ultraviolet irradiation (Zhang and Liu, 2002). MKK 3, 4 and 6 phosphorylate p38 MAPK and these are phosphorylated further upstream by apoptosis signal regulated kinase, MKKK 1-4, TGF- β -activated protein kinase and mixed lineage kinase (Zhang and Liu, 2002)

1.5.1.2.1 p38 and endothelial cell proliferation

p38 has been shown to be involved in angiogenesis, suggesting it is involved in EC growth. VEGF and sesamin have both been shown to promote angiogenesis with a concomitant increase in p38 activation however pre-treatment with SB203580, a p38 MAPK inhibitor, has no effect on VEGF- and sesamin-induced proliferation but does attenuate HUVEC migration (Rousseau *et al.*, 1997; Chung *et al.*, 2010b). In addition, hydrogen sulfide promotes HUVEC migration in a SB203580-inhibitable manner (Papapetropoulos *et al.*, 2009). These data suggest p38 has no role in endothelial cell proliferation but is important for endothelial cell migration, an essential process in angiogenesis.

1.5.1.2.2 p38 and vascular smooth muscle cell growth

In vitro and *in vivo* data suggest p38 is involved in VSMC proliferation. PDGF promotes proliferation of A10 cells, a VSMC cell line, and RAoSMC which is inhibited by SB202190 (Proctor *et al.*, 2008), a p38 MAPK inhibitor. *In vivo*, p38 α MAPK inhibition has been shown to reduce neointimal development following carotid injury (Proctor *et al.*, 2008). Furthermore, mice which have undergone aortic allografts and treated with SB239063, a p38 MAPK inhibitor, exhibit reduced neointimal hyperplasia in comparison to non-treated animals (Ollinger *et al.*, 2008).

1.5.1.3 JNK/SAPK

JNK/SAPK proteins are encoded by three genes with at least 12 splice variants (Pearson *et al.*, 2001). They are activated by various stimuli including ultraviolet light, cytokines and growth factors and are involved in various physiological processes including cell proliferation, cell survival, cell death, DNA repair and metabolism (Karin and Gallagher, 2005). MKK 4/7 phosphorylate JNK/SAPK and these are phosphorylated further upstream by the same kinases as those for MKK 3, 4 and 6 (Zhang and Liu, 2002).

1.5.1.3.1 JNK/SAPK and endothelial cell proliferation

There is limited evidence for a role for JNK in endothelial cell growth. In HUVEC, VEGF has no effect on JNK activation (Yu and Sato, 1999). Terbinafine, an anti-fungal agent, suppresses HUVEC proliferation that is absent in HUVEC transfected with a JNK 1 dominant negative (Hsu *et al.*, 2009). Serum starvation and ceramide treatment activates JNK in human dermal microvascular endothelial cells, which is inhibited by the presence of VEGF (Gupta *et al.*, 1999), suggesting JNK is involved in apoptosis in endothelial cells.

1.5.1.3.2 JNK/SAPK and vascular smooth muscle cell growth

Unlike in endothelial cells, JNK has a role in VSMC growth. RAoSMC infected with a dominant negative JNK mutant exhibit reduced proliferation in response to PDGF (Zhan *et al.*, 2003). In addition, serum and Ang II promotes RAoSMC proliferation which is attenuated by SP600125, a JNK inhibitor (Lu *et al.*, 2006; Chiou *et al.*, 2009), suggesting in VSMC JNK activation can promote proliferation.

1.5.2 Phosphatidylinositol-3 Kinase

Phosphatidylinositol-3 kinases (PI3K) are a family of enzymes involved in a wide variety of cellular processes including cell survival, proliferation, apoptosis, differentiation and motility (Brader and Eccles, 2004). A key downstream effector of PI3K is the 60 KDa serine threonine kinase Akt, also known as protein kinase B

(PKB). Phosphorylation of Thr308 and Ser473 are required for full activation of Akt (Alessi *et al.*, 1996). Upon activation, Akt phosphorylates multiple substrates including eNOS, glycogen synthase kinase (GSK)-3, mammalian target of rapamycin (mTOR) and Bad, amongst others, which are involved in the regulation of various cellular functions including cell proliferation, survival and insulin signalling (Coffer *et al.*, 1998;Shiojima and Walsh, 2002). There are 3 mammalian isoforms of Akt that are encoded by three distinct genes, Akt1/PKB α , Akt2/PKB β and Akt3/PKB γ . All 3 Akt genes are widely expressed however Akt1 is most abundant in brain, heart, lung and endothelial cells whereas Akt2 is expressed predominantly in skeletal muscle and Akt3 in brain and kidney (Shiojima and Walsh, 2002).

1.5.2.1 PI3K and endothelial cell proliferation

PI3K signalling is well documented and characterised in endothelial cell proliferation. VEGF, a potent endothelial cell mitogen, has been shown to promote endothelial cell growth via multiple signalling pathways including the PI3K/Akt pathway (Yu and Sato, 1999;Gliki *et al.*, 2002). VEGF stimulated PI3K/Akt activation has been shown to mediate the activation of eNOS (Dimmeler *et al.*, 1999), by directly phosphorylating Ser1179, leading to an increase in NO production (Fulton *et al.*, 1999). It has been suggested that VEGF-induced endothelial cell proliferation is via NO as N^G-nitro-L-arginine methyl ester (L-NAME), a NOS inhibitor, blocks VEGF-induced endothelial cell mitogenesis (Ziche *et al.*, 1997). In addition, NO has also been shown to promote endothelial cell proliferation via the PI3K pathway (Kawasaki *et al.*, 2003), demonstrating a possible positive feedback mechanism. *Pueraria thunbergiana* extract, Korean red ginseng water extract, icariin and sesamin, promote endothelial cell proliferation in an Akt-dependent manner, which is also blocked by the NOS inhibitor, N^G-methyl-L-arginine (L-NMA), without affecting VEGF expression (Kim *et al.*, 2007;Chung *et al.*, 2008;Chung *et al.*, 2010a;Chung *et al.*, 2010b). Furthermore, fractalkine stimulates Akt phosphorylation promoting HUVEC proliferation in a NO-dependent manner (Lee *et al.*, 2006). These observations clearly demonstrate that activation of the PI3K/Akt pathway promotes endothelial cell proliferation, in part via NO.

1.5.2.2 PI3K and vascular smooth muscle cell growth

Akin to endothelial cells, VSMC proliferation can be altered by PI3K signalling. Ang II promotes proliferation of RAoSMC with a concomitant increase in Akt activation which is inhibited by wortmannin, a PI3K inhibitor (Chiou *et al.*, 2009). PDGF, C-peptide and bradykinin promote VSMC proliferation that is inhibited by LY294002, a PI3K inhibitor (Yang *et al.*, 2005; Walcher *et al.*, 2006; Choi *et al.*, 2010). Thus akin to endothelial cells, the PI3K/Akt pathway promotes VSMC proliferation.

1.6 The cell cycle

The cell cycle is a highly regulated process that permits cells to replicate (Figure 8). It is comprised of four phases: mitosis (M), first gap (G1), synthesis (S) and second gap (G2). Cell cycle progression is primarily regulated by cyclin dependent kinases (CDK), a family of serine/threonine kinases, which are regulated by cyclins, to promote cell cycle progression and cyclin dependent kinase inhibitors (CKI), to inhibit cell cycle progression. CDK protein levels remain stable throughout the cell cycle, in contrast to cyclin levels which are altered throughout the cell cycle (Vermeulen *et al.*, 2003). Following stimulation, the D type cyclins (cyclin D1, D2, D3) bind to CDK4 or CDK6 to allow G1 phase entry, in which the cell prepares for DNA synthesis. Cyclin D-CDK4/6 complexes phosphorylate the retinoblastoma protein, which is bound to E2F, a transcription factor, and this phosphorylation releases E2F allowing transcription of genes required for progression from G1 phase to S phase of the cell cycle. Cyclin E binding to CDK2 is required for the cells to enter the S phase (Ohtsubo *et al.*, 1995), in which DNA replication occurs. During the S phase, cyclin A binds to CDK2, which is required for DNA replication to occur (Girard *et al.*, 1991). In late G2 and early M phases, cyclin A complexes with CDK1 to promote entry into the mitotic phase, which is further regulated by cyclin B complexing with CDK1 (Vermeulen *et al.*, 2003).

Two classes of CKI exist: INK4 family comprised of p15, p16, p18 and p19 and Cip/Kip family comprised of p21^{waf1/cip1}, p27^{kip1} and p57. The INK4 family bind predominantly to Cdk4 and Cdk6 preventing cyclin D binding whilst the Cip/Kip

family inactivate cyclin-CDK complexes throughout the cell cycle (Vermeulen *et al.*, 2003).

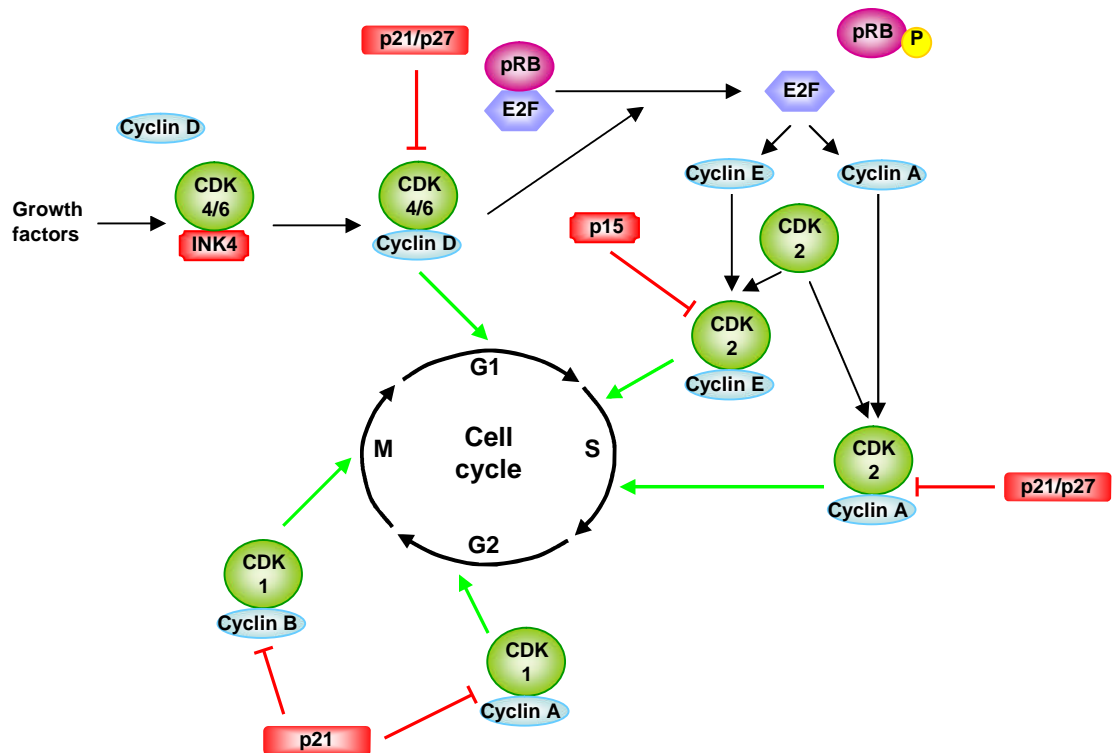

Figure 8 - An overview of the cell cycle

CDK - Cyclin dependent kinase, G1 - first gap, G2 - second gap, M - mitosis, pRB - retinoblastoma protein, S - synthesis

In endothelial cells, VEGF augments expression of the cell cycle promoters cyclin D1 (Pedram *et al.*, 1998; Favot *et al.*, 2004; Min *et al.*, 2004), cyclin E (Min *et al.*, 2004) and cyclin A (Favot *et al.*, 2004) and reduces expression of the cell cycle inhibitors p21^{waf1/cip1} and p27^{kip1} (Favot *et al.*, 2004). This cell cycle protein profile underlies the pro-mitogenic effects of VEGF. Ang II, a promoter of VSMC growth, has been shown to have no effect or increase cyclin D1 expression (Zahradka *et al.*, 2002; Kintscher *et al.*, 2003; Chen *et al.*, 2009; Zhou *et al.*, 2009). In addition, Ang II attenuates p21^{waf1/cip1} (He *et al.*, 2009; Chen *et al.*, 2009; Zhou *et al.*, 2009) and p27^{kip1} expression (Zhou *et al.*, 2009), thereby promoting cell cycle progression and VSMC growth. These observations highlight that mitogenic factors augment expression of cell cycle promoters whilst concomitantly reducing expression of cell cycle inhibitors, promoting proliferation.

1.6.1 CNP and cell cycle proteins

Very few studies have investigated the effect of CNP on cell cycle protein expression. Adenovirus mediated gene transfer of CNP to rat VSMC inhibits growth at the G1 phase (Doi *et al.*, 1997). Furthermore, RAoSMC infected with an adenovirus encoding CNP have increased p21^{waf1/cip1} mRNA expression at 2, 4 and 6 days, whilst p16 mRNA levels are increased only after 6 days (Doi *et al.*, 2001). The effect of CNP on cell cycle protein expression in endothelial cells has not been investigated.

1.7 Aims

In summary, there is compelling evidence linking CNP with vascular homeostasis and disease. The unique mitogenic profile of CNP on vascular cells suggests that CNP therapy in vascular diseases such as atherosclerosis and restenosis, which are characterised by endothelial cell damage and smooth muscle cell proliferation, may have potential benefit. However, to date there has been a lack of studies delineating the receptor and signalling pathways underlying CNP-dependent regulation of endothelial cell and VSMC proliferation. The multi-faceted cytoprotective effects of CNP on the blood vessel (i.e. vasodilatation, anti-leukocyte, anti-platelet) suggest it is a key anti-atherogenic mediator. Moreover, identification of CNP as an EDHF, gives rise to the thesis that this peptide regulates local blood flow and blood pressure, although whether endogenous CNP has a physiological role in cardiovascular homeostasis is unknown.

In this thesis I have attempted to address these uncertainties by using a novel endothelial cell specific CNP KO mouse model, human umbilical vein endothelial cells, primary rat aortic smooth muscle cells, NPR-C KO endothelial and vascular smooth muscle cells to investigate the following hypotheses:

- 1) CNP regulates endothelial cell proliferation through NPR-C-triggered activation of the MAPK pathways
- 2) Cell cycle protein expression in HUVEC and RAoSMC is altered in an NPR-C and ERK 1/2-dependent manner
- 3) Mice deficient in endothelial CNP exhibit vascular dysfunction *in vitro* and are hypertensive

Chapter 2

Methods

2 Methods

2.1 Materials

All reagents were from Sigma-Aldrich (Poole, UK) unless otherwise stated. CNP (Calbiochem, Nottingham, UK) and cANF⁴⁻²³ were dissolved in distilled water to a concentration of 1 mM. PD98059, SB203580 and SP600125 (Axxora, Nottingham, UK) were reconstituted in dimethyl sulphoxide (DMSO) to a concentration of 30 mM. LY294002 and wortmannin (Calbiochem) were dissolved in DMSO to a concentration of 10 mM. M372049, a kind gift from Dr. C. Veale (Astrazeneca Pharmaceuticals, Wilmington, USA), was resuspended in distilled water to a concentration of 1 mM. *Pertussis toxin* (PTx; Calbiochem) was reconstituted in distilled water to a concentration of 100 µg/ml. VEGF (Peprotech, London, UK) was dissolved in distilled water to a concentration of (10 µg/ml). Ang II was reconstituted in distilled water to a concentration of 1 mM. U46619 (Biomol International, Exeter, UK) was dissolved in ethanol to a concentration of 1 mM. Phenylephrine (PE) and ACh were resuspended in distilled water to a concentration of 10 mM. Spermine-NONOate (Sper-NO; Calbiochem) was dissolved in distilled water to a concentration of 10 mM immediately prior to use. All reagents were stored at -20°C.

2.2 Cell Culture

2.2.1 Human umbilical vein endothelial cell

Pooled donor human umbilical vein endothelial cells (HUVEC; Promocell, Heidelberg, Germany) were grown using basal endothelial growth medium-2 (EGMTM-2; Lonza, Slough, UK) supplemented with a bulletkit containing fetal calf serum (FCS; final concentration 2 %), human epidermal growth factor, hydrocortisone, GA-1000, VEGF, human fibroblast growth factor-B, R³-insulin growth factor, ascorbic acid, heparin (concentrations are proprietary information). The media was changed every 2/3 days until cells reached ~90 % confluency and then passaged by washing with HEPES (Promocell), incubating with trypsin/EDTA (Promocell) until cells had detached (approximately 2 min) followed by trypsin neutralisation with trypsin neutralising solution (Promocell). Cells were then

centrifuged at 200 g for 4 min at room temperature and the supernatant removed. Cells were then resuspended in media, a cell count performed and cell viability determined.

Cell viability was determined by mixing equal volumes of cell suspension and trypan blue (Life Technologies, Paisley, UK) and approximately 20 μ l of the resulting solution was placed on a haemocytometer and visualised using an inverted microscope (Axiovert 25, Carl Zeiss MicroImaging Inc., Hertfordshire, UK). Live cells were counted as unstained cells and dead cells were stained blue. Cells were used for experimentation if viability was greater than 90 % and up to and including passage 6.

2.2.2 Primary rat aortic smooth muscle cell isolation

RAoSMC isolation was carried out by Dr Catherine Panayiotou (Panayiotou, 2007). The cells stained positive for smooth muscle specific α -actin and showed a typical hill and valley morphology (data not shown). Cells were passaged by trypsinisation with cells of passage 4-15 used for experimentation.

2.2.3 Biomagnetic purification of mouse pulmonary microvascular endothelial cells

Mouse pulmonary microvascular endothelial cells (PMEC) were isolated from C57/BL6 and NPR-C KO mice by a combination of methods previously described (Hartwell *et al.*, 1998; Kuhlencordt *et al.*, 2004). Animals were killed by cervical dislocation and the lung was removed and placed in DMEM/Nutrient Mixture F12 (DMEM/F12; Invitrogen) on ice. The lung tissue was washed 3 times in DMEM/F12 and the central cartilaginous lung tissue removed. The remaining tissue was dissected finely and incubated with 0.1 % collagenase, in DMEM/F12, for 1 h at 37°C. The tissue was then passed through a 19 gauge needle, to disperse cells, and subsequently through a 70 μ m filter. The resulting cells were centrifuged at 200 g for 5 min at 21°C and resuspended in DMEM/F12 supplemented with 20 % FCS, 100 U/ml penicillin, 100 μ g/ml streptomycin, 1 μ l/ml endothelial cell growth supplement/heparin (Promocell) and 50 μ g/ml endothelial cell growth supplement. Cells were grown in a 0.1 % gelatin coated flask in a humidified incubator with 5 % CO₂ in air at 37°C. The media was changed after 24 h and changed every 2/3 days until cells were 80-90 %

confluent. 4×10^6 Dynabeads coated in sheep anti-rat IgG (Invitrogen) were washed 3 times in PBS and then incubated overnight with 5 μ g anti-intercellular adhesion molecule (ICAM)-2 (CD102, endothelial specific marker; BD Biosciences, Oxford, UK) on a rotator. The Dynabeads were then washed 3 times in PBS, media was aspirated and the Dynabeads added to the isolated pulmonary vascular cells for 1 h in a humidified incubator at 37°C. Cells were trypsinised and magnetically separated. This involved transferring cells to a 15 ml centrifuge tube which was placed in a DynaMag™-15 (Invitrogen, Oslo, Norway) and left for 10 min. Cells expressing ICAM-2 are bound to the Dynabeads which are attracted to the magnet and hence collect on the side of the tube; the remaining solution, containing non-bound cells, was aspirated. Cells were washed and magnetically separated a second time and then plated. Cells displayed a typical cobblestone appearance (data not shown) and expressed ICAM-2 as shown by Flow cytometry (Figure 9; conducted by Dr Inmaculada Villar), demonstrating these are endothelial cells. Cells up to passage 4 were used.

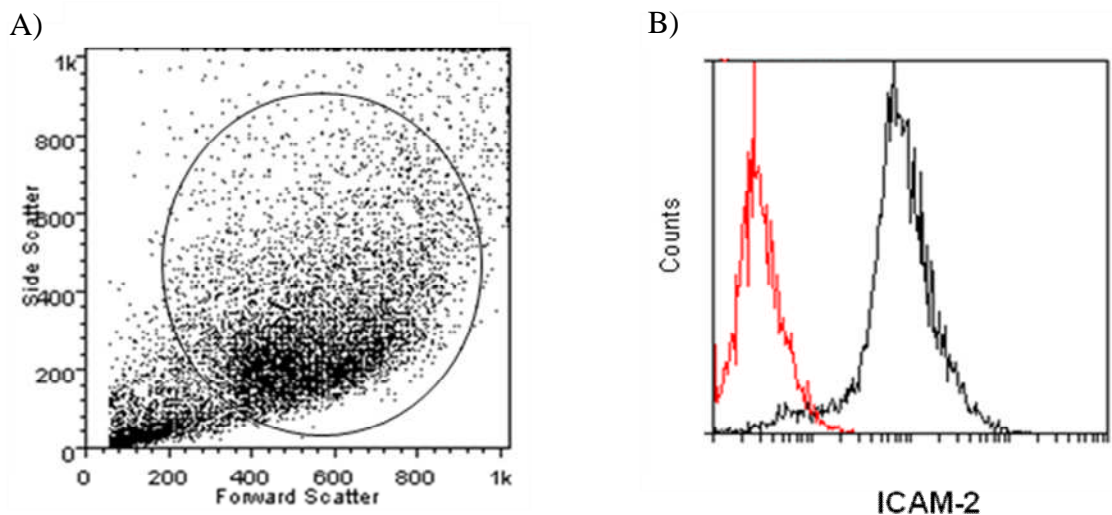

Figure 9 - Flow cytometry analysis of PMEC

A) Representative forward scatter-side scatter dot-plot of cell populations B) Representative histogram of ICAM-2 expression of positives cells (black) and isotype control (red).

2.2.4 Freezing cells

Long term storage of cells was achieved by storing cells in liquid nitrogen. HUVEC and PMEC were frozen at passage 3 or below and RAoSMC passage 8 or below. Following cell viability determination, 10 % DMSO was added to the cells and the cells transferred to cryogenic vials at a concentration of 0.5×10^6 /ml. The vials were then placed in a Cryo 1°C freezing container (Fisher Scientific, Leicestershire, UK) and stored overnight in a -80°C freezer. The following day the vials were placed in liquid nitrogen.

2.2.5 Thawing cells

Vials were removed from liquid nitrogen storage and were placed in a water bath at 37°C with constant agitation. The top was slightly unscrewed, to allow pressure release, and was promptly re-tightened. Once the majority of the vial was thawed, 1 ml pre-warmed media was added to the vial, under aseptic conditions and the vial contents transferred into 10 ml media. Cells were centrifuged at 200 g for 4 min at room temperature and the supernatant removed, in order to remove the DMSO. Cells were then resuspended in media, plated and the media changed the following day.

2.3 Measurement of endothelial cell proliferation

A 5-bromo-2'-deoxyuridine (BrdU) cell proliferation ELISA (Roche Diagnostics, East Sussex, UK) was used to assess endothelial cell proliferation, according to the manufacturer's guidelines. The BrdU assay functions by measuring BrdU incorporation during DNA synthesis and is a non-radioactive alternative to [³H]-thymidine incorporation. Initial experiments were conducted to define optimum proliferation conditions. HUVEC were seeded from 500 cells/well up to 100,000 cells/well, in a 96 well plate, for 24 h in growth medium. Media was then changed to basal growth medium containing 0.1 % FCS and 5 % of supplements (i.e. a 1 in 20 dilution of normal growth medium with basal media, to quiesce the cells). After 23 h 30 min the media was then changed back to normal growth medium and cells were incubated with or without inhibitor (M372049 (1 μM), PD98059 (30 μM), SB203580 (30 μM), SP600125 (3 μM), wortmannin (500 nM), LY294002 (10 μM)) for 30 min.

Following inhibitor incubation, cells were treated with or without CNP (1 pM - 1 μ M) for 24 h. Following 20 h incubation, BrdU was incubated with the cells for 4 h, after which culture medium was removed and the cells fixed. The cells were then incubated with anti-BrdU peroxidase (POD), washed and tetramethyl-benzidine added. The product was quantified by measuring absorbance at 370 nm (reference 492 nm) using a Molecular Devices 96 well microplate reader (Menlo Park, California, USA).

PMEC were seeded at 500 cells/well, in a 96 well plate, for 24 h in growth medium. Media was then changed to basal growth medium containing 0.1 % FCS and 0.5 % supplements (i.e. a 1 in 200 dilution of growth medium with DMEM/F12, to quiesce the cells). After 24 h the media was changed back to growth medium and the cells treated with CNP (100 pM) for 24 h. Following 20 h incubation BrdU was incubated with the cells for 4 h and the BrdU assay conducted, as described above. All BrdU experiments were conducted in triplicate, i.e. each treatment was performed on 3 separate wells of the same endothelial cell population equating to an n=1.

2.4 Determination of MAPK phosphorylation and cell cycle proteins

HUVEC and RAoSMC were seeded at 750,000 cells/10 cm dish. The following day, media was changed and HUVEC were treated with CNP (100 pM) for 0, 0.5, 1, 3, 6 or 24 h. RAoSMC were seeded and the following day media changed to 0.1 % FCS. RAoSMC were left overnight in 0.1 % FCS, the media changed and then treated with CNP (1 μ M) for 0, 0.5, 1, 3, 6 or 24 h. Some dishes received 30 min pre-incubation with PD98059 (30 μ M) or M372049 (10 μ M) or PTx (100 ng/ml) before CNP addition. Following CNP incubation cell lysates were prepared. Media was aspirated and the cells washed twice with 4°C PBS (Invitrogen). Cells were lysed by incubating 200 μ l/dish phospho-homogenisation buffer (10 mM Tris, 50 mM NaCl, 30 mM sodium pyrophosphate (NaPP_i), 2 mM EDTA, 50 mM sodium fluoride, 1 mM sodium orthovanadate, 1 mM phenylmethylsulfonyl fluoride, 1 % Triton X-100 and 1 μ g/ml benzamidine, antipain, leupeptin, aprotinin) for 5 min. Each dish was scraped to remove cells and the lysate centrifuged at 12281 g for 5 min at 4°C, after which the pellet was discarded and the lysate stored at -20°C.

2.5 Sample preparation

To quantify total protein all samples were subjected to the Pierce[®] BCA protein assay (Biorad, Hertfordshire, UK). Protein concentrations were determined based upon a standard curve of bovine serum albumin (0, 0.125, 0.25, 0.5, 0.75, 1, 1.5, 2 mg/ml) that was constructed by a series of dilutions from the 2 mg/ml albumin standard provided, with phospho-homogenisation buffer. 25 µl sample or standard were mixed with 200 µl working reagent (50:1 BCA reagent A:B), any bubbles removed and then incubated at 37°C for 10 min. Absorbance was measured at 562 nm using a Molecular Devices 96 well microplate reader and total protein was calculated from the standard curve. Samples were diluted with phospho-homogenisation buffer to ensure equal loading of protein for each run. Samples were diluted 1:1 with 2x sample buffer (20 mM Tris HCl, 2 mM EDTA, 2 % SDS, 10 % β-mercaptoethanol, 20 % glycerol, 0.01 % bromophenol blue and distilled water), a hole made in the top of the eppendorf and the samples boiled at 100°C for 5 min, to denature proteins, followed by centrifugation at 12281 g at 4°C for 5 min. Samples were then placed on ice or stored at -20°C.

2.6 Sodium dodecyl sulphate polyacrylamide gel electrophoresis (SDS PAGE)

Gels were prepared by placing two pieces of glass together in a casting frame which was held upright in a casting stand. A 7.5 % separating gel was prepared by mixing 5x separating buffer (0.375 M Tris base, 0.1 % SDS, distilled water, pH 8.8), 7.5 % acrylamide/bis-acrylamide, 0.1 % ammonium persulphate, 0.1 % N,N,N',N'-tetramethylethylenediamine (TEMED) and distilled water and was pipetted into the glass assembly. A 12 % separating gel was prepared by mixing 5x separating buffer, 12 % acrylamide/bis-acrylamide, 0.1 % ammonium persulphate, 0.06 % TEMED and distilled water. The separating gels were overlaid with isopropanol to remove any bubbles and also to allow the constituents to polymerise. Once the separating gel had polymerised isopropanol was removed and the separating gel was overlaid with stacking gel, which was prepared by mixing 5x stacking buffer (0.125 M Tris base, 0.1 % SDS, distilled water, pH 6.8), 4 % acrylamide/bis-acrylamide, 0.1 %

ammonium persulphate, 0.1 % TEMED and distilled water. The comb was inserted and the gel allowed to polymerise. The comb was removed and the gels transferred to a Protean III gel tank, filled with SDS PAGE running buffer (50 mM Tris base, 0.384 M glycine, 0.1 % SDS, distilled water). 20 µl of each sample and 10 µl of protein marker (precision plus kaleidoscope protein standards; Bio-Rad), were loaded into the wells and separated at 70 – 120 V, until the dye front reached the end of the gel. Proteins were then transferred by semi-dry transfer to a 0.45 µm or 0.2 µm pore nitrocellulose membrane (Hybond™ ECL™, Amersham Biosciences, Buckinghamshire, UK) using a Nova Blot and Multiphor II (Pharmacia Biotech). The anode and cathode were covered with distilled water and electrode paper (GE Healthcare, Buckinghamshire, UK; 7 cm x 10 cm) was soaked in either solution 1 (0.3 M Tris base, 20 % methanol and distilled water), solution 2 (0.025 M Tris base, 20 % methanol and distilled water) or solution 3 (0.04 M 6-amino-n-hexanoic acid, 20 % methanol and distilled water). 6x filter paper soaked in solution 1 was placed on the anode, followed by 3x filter paper soaked in solution 2, then the nitrocellulose membrane, then the gel and finally 9x filter paper soaked in solution 3 was placed on top. The gel was prepared for transfer by removing from the glass plates, wetting the gel with distilled water and discarding the stacking gel. In order to ensure homogenous transfer the filter paper was rolled to ensure removal of bubbles. The electrodes were connected and the Multiphor II run at 150 W for 45 min - 1 h.

2.7 Immunoblotting

Following transfer, the membrane was placed in 0.1 % Ponceau S for 10 min with gentle shaking on a mini orbital shaker (Stuart Scientific, Staffordshire, UK). Ponceau S reversibly stains proteins so that the membrane can be visually inspected to ensure equal loading and transfer. The membrane was washed 3 - 5x with distilled water, to remove Ponceau S, and then incubated with 5 % milk (50 mg/ml original dried skimmed milk; (Marvel, Dublin, Republic of Ireland) dissolved in PBS/Tween (3.25 mM NaH₂PO₄, 7.5 mM Na₂HPO₄, 0.146 M NaCl, 0.1 % Tween 20 and distilled water)) for 1 h at room temperature with gentle shaking; the milk was removed after 15 min and fresh milk added for the remainder of the incubation. Membranes were then transferred to a new tray and probed with primary antibody in 5 % milk (anti-p44/p42 MAP Kinase 1:500, anti-phospho-p44/p42 MAP Kinase (Thr202/Tyr204)

1:500, anti-phospho-Akt (Ser473) 1:500, anti-Akt 1:500, anti-eNOS 1:1,000, anti-phospho-eNOS (Ser1177) 1:1,000, anti-Cyclin D1 1:1,000, anti-p27 Kip1 1:1,000 (New England Biolabs, Hertfordshire, UK), anti-p21 1:500 (BD Pharmingen, Oxford, UK) or anti-actin 1:10,000 (Chemicon International, distributed by Millipore, Watford, UK) overnight at 4°C with constant agitation, apart from anti-actin. Anti-actin was incubated for 10 min, at room temperature with constant agitation. The membrane was then washed with PBS/Tween 5x for 5 min and incubated with shaking for 1 h at room temperature with horseradish peroxidase-conjugated goat anti-rabbit IgG or goat-anti mouse (Dako, Cambridgeshire, UK) diluted 1:2,000 in 5 % milk in wash buffer. The membrane was washed with PBS/Tween 5x for 5 min. In order to visualise the membrane, it was incubated with ECL (Amersham Biosciences) for 2 min, wrapped in clingfilm and placed in a Hypercassette™ (Amersham Biosciences). Under dark room conditions Hyperfilm™ (Amersham Biosciences) was placed on top of the membrane and exposed for varying times and the film processed using a Compact X4 (X-ograph imaging systems, UK). Band densitometry was calculated using AlphaEase software (AlphaInnotech, California, USA).

2.8 Endothelium specific CNP knockout mouse

2.8.1 Generation of endothelium specific CNP knockout mouse

All experiments were carried out in accordance with the Animals (Scientific Procedures) Act 1986, United Kingdom.

The Cre/loxP recombination system was used to generate endothelium specific (ec) CNP KO mice (Figure 10). Cre recombinase, a 38 KDa protein derived from bacteriophage P1, efficiently excises DNA flanked by 2 loxP recognition sites (Sauer and Henderson, 1988). The loxP site is a 34 bp site consisting of two 13 bp palindromic sequences flanking an 8 bp sequence (Sauer, 1998). Initially a targeting vector was designed with 2 loxP sites flanking the entire coding region for *Nppc* in exons 1 and 2. One loxP site was upstream of exon 1; the other was associated with a neomycin selection cassette, downstream of exon 2. The neomycin positive selection cassette, flanked by flippase recombinant target (FRT) sequences, was inserted into the targeting vector to allow selection of transfected embryonic stem cells. The FRT

site allows deletion of the neomycin selection cassette under flippase recombinase action. To ensure only embryonic stem cells expressing the targeted CNP locus were selected a Diphtheria toxin A negative selection cassette was also inserted into the targeting vector. Diphtheria toxin is expressed by cells in which non-homologous recombination occurs and the cells die. Following successful homologous recombination of the targeted CNP locus in embryonic stem cells, the stem cells were injected into blastocysts.

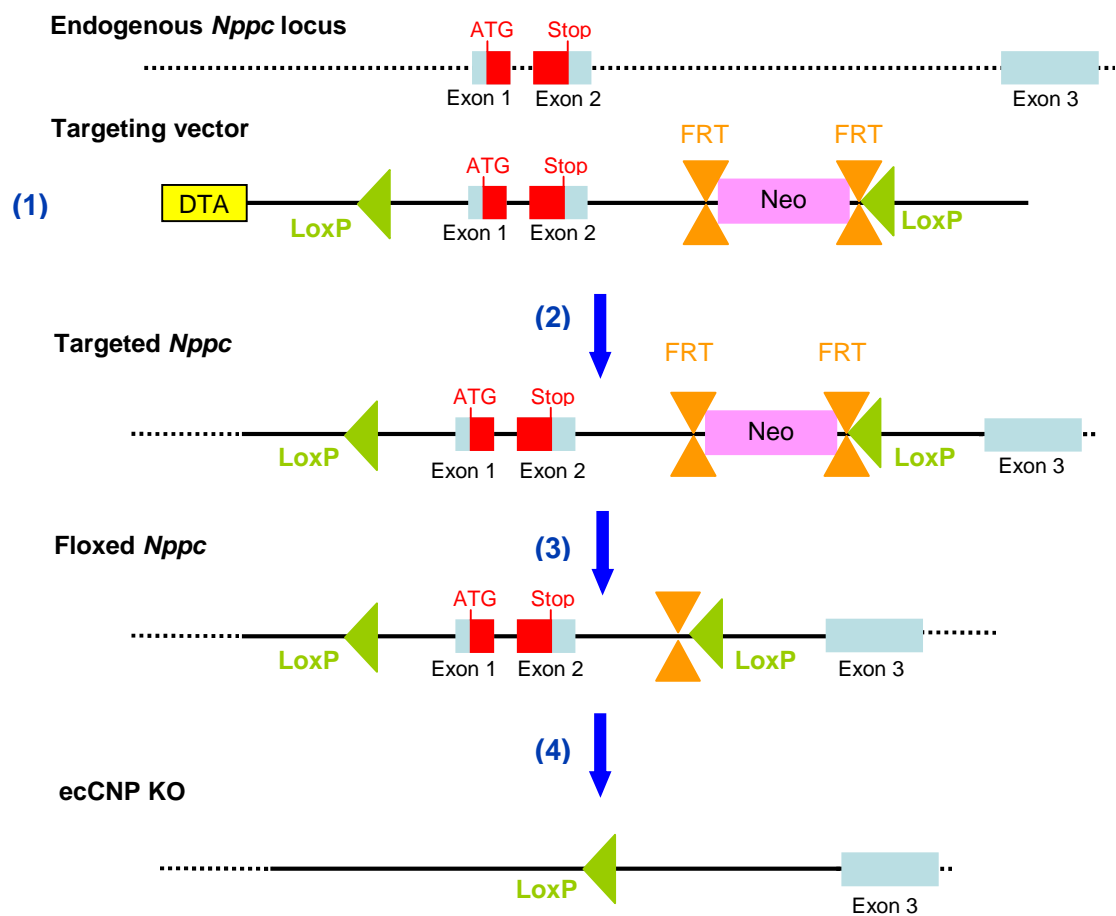

Figure 10 - Schematic representation of the generation of *ecCNP* KO mice

(1) *Nppc* is flanked by 2 loxP (Cre-recombinase) cut sites and also a neomycin selection cassette inserted into the targeting vector; (2) Homologous recombination in embryonic stem cells, which are then injected into blastocysts; (3) Cross animal with targeted *Nppc* locus with an animal expressing flippase enzyme which cuts at FRT sites and excise the neomycin selection cassette; (4) Cross animal with floxed *Nppc* locus with a Tie2-Cre expressing animal. DTA - Diphtheria toxin A, *ecCNP* KO - Endothelium specific C-type natriuretic peptide knockout, FRT - Flippase recombinant target, Neo - Neomycin

Chimeric mice were generated in which the CNP locus (exon 1 and 2) and the neomycin selection cassette was flanked by two loxP sites. Mice were then bred until germ line transmission occurred. These mice were crossed with flippase recombinase expressing mice resulting in *in vivo* excision of the neomycin selection cassette and generation of Nppc^{flox/+} mice. Nppc^{flox/+} mice were crossed with Tie2Cre expressing animals in which Cre recombinase expression is driven by the endothelial specific Tie2 promoter, resulting in selective excision of the CNP gene from endothelial cells. The Tie2 gene encodes an angiotensin receptor and contains promoter and enhancer regions that drive transgene expression specifically in endothelial cells (Schlaeger *et al.*, 1997). Tie2-lacZ transgenic mice demonstrate pan endothelial specific pattern of lacZ staining throughout embryogenesis and adulthood (Schlaeger *et al.*, 1997). This expression system has previously been used to remove NPR-A selectively from the endothelium (Sabrane *et al.*, 2005).

Nppc^{flox/+} Tie2⁺ floxed mice were setup as breeding pairs, leading to the generation of Nppc^{+/+} Tie2⁻ (WT), Nppc^{+/+} Tie2⁺, Nppc^{flox/+} Tie2⁻, Nppc^{flox/+} Tie2⁺, Nppc^{flox/flox} Tie2⁻ and Nppc^{flox/flox} Tie2⁺ (ecCNP KO) offspring. ecCNP KO carry the targeted CNP locus and also express Tie2 leading to the removal of the CNP gene from endothelial cells.

2.8.2 Genotyping of animals

Mouse ear clip samples were digested using DirectPCR lysis reagent (Viagen Biotech, distributed by Bioquote, York, UK) and 0.3 mg/ml proteinase K overnight at 55°C with shaking. The following day, samples were incubated at 85°C for 45 min to denature proteinase K after which the samples were ready for use. The Flpe mediated neomycin excision was detected using the floxed CNP primers (Table 2); Figure 11 illustrates the binding sites of these primers. The PCR reaction mixture consisted of 2 µM primers, 2x BioMix (containing ultra stable Taq DNA polymerase, ultra pure dNTPs and MgCl₂; Bioline, London, UK), DNA template and distilled water. PCR conditions were as follows: 94°C for 2 min followed by 35 cycles of denaturation at 94°C for 30 s, annealing at 60°C for 1 min, polymerisation at 68°C for 2 min followed by a final extension at 68°C for 10 min. PCR products were mixed with 5x DNA loading buffer (Bioline), stained with SYBR safe DNA gel stain (Invitrogen), resolved

by gel electrophoresis on a 2 % agarose gel and viewed using an AlphaImager (AlphaInnotech).

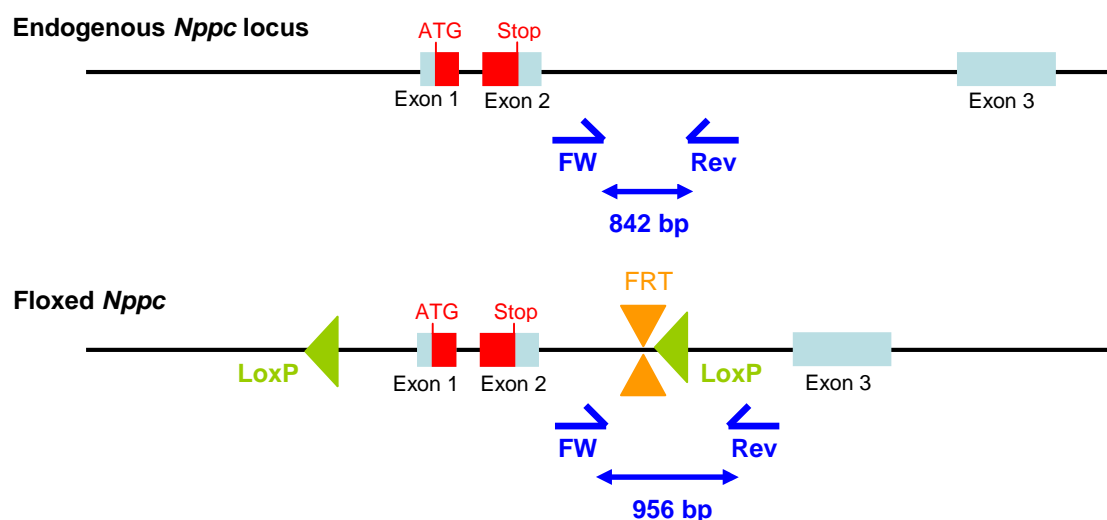

Figure 11 - Schematic representation of Floxed CNP primers binding sites and expected product sizes

PCR of ear clip samples from WT mice generated a 842 bp DNA sequence. PCR of ear clip samples from mice with a floxed CNP locus generated a 956 bp DNA sequence, due to incorporation of FRT and loxP sites.

The expression of Tie2 was detected using Tie2 primers (Table 2). The PCR reaction mixture was identical to the one described above. PCR conditions were as follows: 95°C for 10 min followed by 40 cycles of denaturation at 95°C for 30 s, annealing at 58°C for 1 min, polymerisation at 72°C for 1 min followed by a final extension at 72°C for 10 min. PCR products were visualised as described above.

Primer Name	Primer Sequence
Floxed CNP Forward	5'-CCTTTATGCCAAGAGAAGCTTCCAGGAGG-3'
Floxed CNP Reverse	5'-TCCTTCCTGACTTCCTTCTGCTCTCTATCC-3'
Tie2 Forward	5'-CCCTGTGCTCAGACAGAAATGAG-3'
Tie2 Reverse	5'-CGCATAACCAGTGAAACAGCATTGC-3'

Table 2 - Name and sequence of primers used to genotype offspring

2.9 Mouse isolated thoracic aorta

Mice were killed by cervical dislocation and the aorta was carefully removed and cleaned of fat and connective tissue. The aorta was cut into 3 or 4 pieces approximately 4 mm in length and mounted in 10 ml organ baths containing Krebs bicarbonate buffer (composition (mM): Na⁺ 143, K⁺ 5.9, Ca²⁺ 2.5, Mg²⁺ 1.2, Cl⁻ 128, HCO₃⁻ 25; HPO₄²⁻ 1.2, SO₄²⁻ 1.2, D-glucose 11) maintained at 37°C gassed with 95 % O₂/5 % CO₂. Tension was set at 0.3 g and the vessels allowed to equilibrate for approximately 1 h, over which time the vessels were washed every 15 - 20 min and the tension reset to 0.3 g if required. After equilibration, the vessels were primed with KCl (48 mM). The vessels were washed thoroughly and cumulative concentrations of PE (1 nM - 10 μM) or U46619 (100 pM - 1 μM) were added. The vessels were washed until basal tone was reached and then vessels were contracted to approximately 80 % of the maximum PE-induced contraction. Endothelial integrity was assessed by adding cumulative concentrations of ACh (1 nM - 10 μM); vessels with < 50 % relaxation were deemed endothelium denuded and discarded. Vessels were then washed and were pre-contracted to approximately 80 % of the maximum PE-induced contraction and cumulative concentrations of CNP (1 nM – 1 μM) and Sper-NO (100 pM – 30 μM) were added. Data were captured using Powerlab and Chart version 6 (AD Instruments, Oxfordshire, UK).

2.10 Mouse blood pressure recording

Mice were implanted with a DSI PhysioTel® PA-C10 telemetry probe (Data Sciences International, Minneapolis, USA). Each probe was cleaned and sterilised according to the manufacturers guidelines. The probe was soaked in Terg-A-Zyme® (Fisher Scientific) for a maximum of 72 h, rinsed with water, dried and stored until the day of implantation. Prior to insertion the probe was sterilised by soaking in NuCidex® (Johnson and Johnson, New Jersey, USA) for a maximum of 40 min, then washed with sterile saline and finally re-gelled to ensure the absence of air bubbles in the catheter tip. Mice were sedated with 5 % isoflurane and anaesthesia was maintained using 2 % isoflurane. An incision was made in the neck and the left carotid artery was isolated and cleaned. A small incision was made in the carotid and the catheter

inserted ensuring no bubbles formed. The tip of the catheter was placed into the aortic arch, securely fastened and the transmitter body placed subcutaneously on the right flank. The incision was stitched and each animal received post-operative analgesia and antibiotics consisting of 0.3 µg vetergesic (Reckitt Benckiser, York, UK), 15 ng baytril (Bayer, Newbury, UK) and 0.5 ml saline (Baxter, Newbury, UK) subcutaneously. Animals were left to recover between 7-10 days, under a 12 h light-dark cycle, after which haemodynamic recordings were taken for 64 h over the weekend to minimise noise disturbances. Mean arterial blood pressure (MABP), heart rate and activity were recorded for 2 min at 15 min intervals using Dataquest A.R.T software (Data Sciences International, USA).

2.11 Statistics

Statistical analyses were carried out using GraphPad Prism version 5 (GraphPad software, California, USA). An unpaired, two tailed t-test was carried out when comparing two groups. When comparing 3 or more groups a one-way ANOVA followed by a Bonferroni post test was conducted. For organ bath experiments, curves were fitted to the data using nonlinear regression and the concentration of each drug, giving a half-maximal response (EC_{50}), was used to compare potency. Curves were analysed using two-way ANOVA. Data are not significant unless otherwise stated, where $P < 0.05$ is defined as significant.

In Figure 28, 32 and 33 vehicle (DMSO) caused an increase in expression of the respective proteins. In order to quantify the effect of PD98059 the effect of DMSO alone was subtracted from the treatment groups that had received DMSO. In retrospect, it would have been more appropriate to add DMSO to the CNP treatment group as well, so that all treatments received DMSO and then a fair comparison could be made between the groups.

Chapter 3

Results 1

3 Results 1

3.1 Introduction

Atherosclerosis and restenosis are characterised by endothelial cell damage and neointimal hyperplasia (Nabel, 1991; Raines and Ross, 1993). Previous studies have shown CNP to enhance endothelial cell proliferation *in vitro* and promote re-endothelialisation *in vivo* (Doi *et al.*, 2001; Ohno *et al.*, 2002; Qian *et al.*, 2002; Yamahara *et al.*, 2003; Pelisek *et al.*, 2006). The intracellular mechanism(s) by which CNP promotes mitogenesis is unknown, although some studies have suggested that this effect is NPR-B mediated (Ohno *et al.*, 2002; Yamahara *et al.*, 2003).

Studies described in this section investigate the hypothesis that in endothelial cells, CNP activates NPR-C, which mediates MAPK activation resulting in altered cell cycle protein expression to promote growth. This was achieved by assessing endothelial cell proliferation in response to CNP in the presence of an NPR-C antagonist, MAPK inhibitors and endothelial cells isolated from NPR-C KO mice. In addition, MAPK phosphorylation (i.e. activation) was assessed in the presence of NPR-C blockade and cell cycle protein expression determined in the presence of MAPK inhibition.

Data from our lab have demonstrated that CNP-induced inhibition of VSMC proliferation is mediated via activation of NPR-C resulting in ERK 1/2 phosphorylation (Panayiotou, 2007); however the downstream targets are unknown. Thus, I also investigated if a NPR-C-dependent ERK 1/2 activation resulted in a differential effect on cell cycle protein expression in VSMC to bring about growth arrest.

3.2 Defining optimum conditions for measuring CNP-induced HUVEC proliferation

In order to identify the optimum cell density, FCS concentration and CNP incubation time to use, initial studies explored the effect of these different parameters on cell growth. Initially, 1 μ M CNP was used to determine incubation time, cell density and FCS concentration as this is commensurate with the maximal concentration of CNP released from endothelial cells in response to ACh (Chauhan *et al.*, 2003) and gives maximum relaxation in isolated thoracic aorta and mesenteric arteries (Madhani *et al.*, 2003)

HUVEC were grown in either basal growth medium (2 % FCS plus supplements), a 1 in 20 dilution of the basal growth medium (equivalent to 0.1% FCS plus 5 % supplements) or 0.1 % FCS only, ranging from 500 cells/well up to 100,000 cells/well (Figure 12). Absorbance was greatest at 1,000 or 2,500 cells/well and decreased as cell density increased, indicating at higher cell densities the cells were not proliferating; this is likely due to contact inhibition. As a result, the cell density chosen for future experiments was 1,000 cells/well. 2 % FCS with supplements was also chosen for subsequent growth studies as this media composition resulted in a consistent increase in proliferation. A similar increase in growth was observed when incubating 1 μ M CNP for 24 h (Figure 12) or 48 h (Figure 13). Thus, all further proliferation experiments were conducted using 1,000 HUVEC/well, in 2 % FCS plus supplements and incubated with CNP for 24 h.

Effect of CNP (24 h) on HUVEC proliferation with differing cell density and media composition

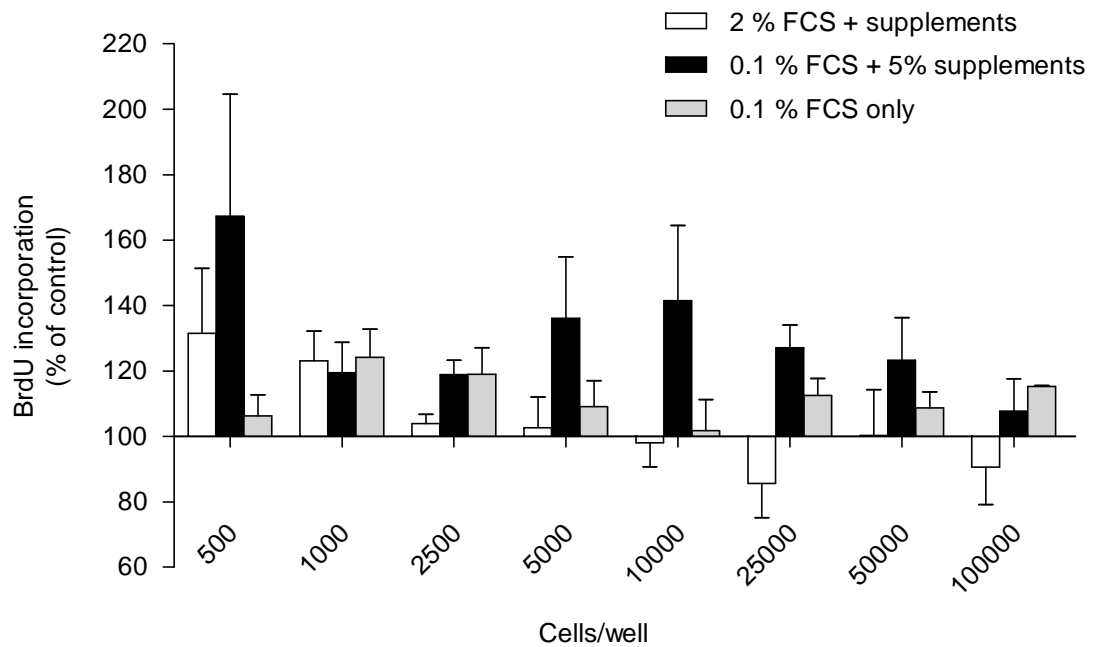

Figure 12 - BrdU incorporation in response to CNP (1 μ M) for 24 h in HUVEC

HUVEC (500 cells/well - 100,000 cells/well) were grown in 3 different media conditions. Data are represented as mean \pm SEM, expressed as a percentage of basal growth (control, set at 100 %); n=3-5 conducted in triplicate.

Effect of CNP (48 h) on HUVEC proliferation with differing cell density and media composition

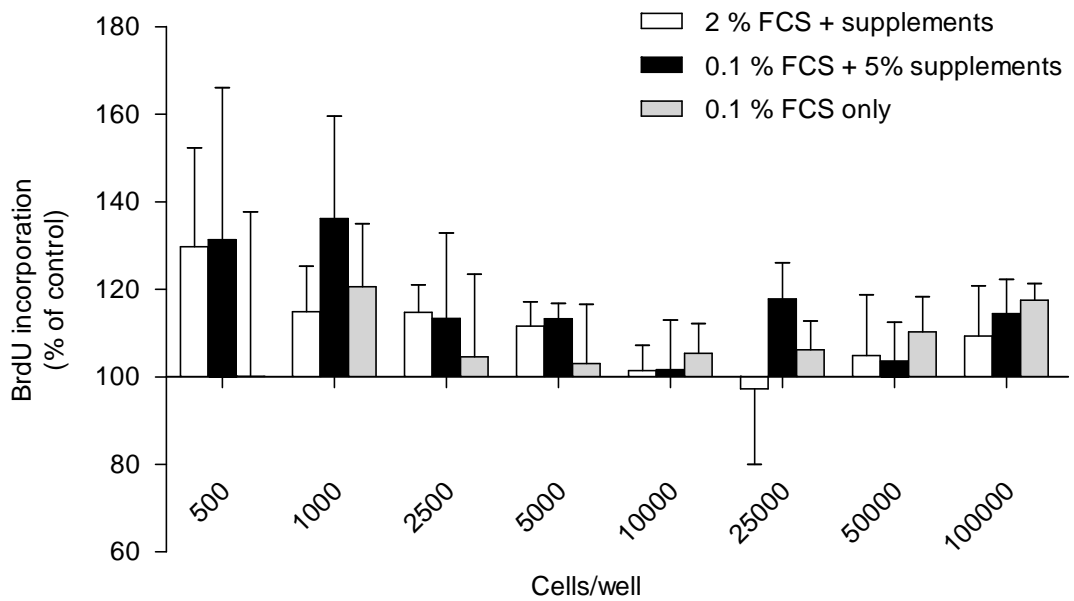

Figure 13 - BrdU incorporation in response to CNP (1 μ M) for 48 h in HUVEC

HUVEC (500 cells/well - 100,000 cells/well) were grown in 3 different media conditions. Data are represented as mean \pm SEM, expressed as a percentage of basal growth (control, set at 100 %); n=3-5 conducted in triplicate.

3.3 CNP-induced HUVEC proliferation is part NPR-C mediated

In order to determine a concentration-response relationship for the proliferative effect of CNP on endothelial cells, HUVEC were treated with CNP (1 pM – 1 μ M) for 24 h. CNP caused a bi-phasic response, with all concentrations tested causing a significant increase in HUVEC proliferation, in comparison to control, except for 1 pM CNP (Figure 14). CNP (100 pM) was chosen for future experiments in endothelial cells as it achieved the greatest increase in proliferation.

To identify the NPR responsible for the positive effect of CNP on endothelial cell proliferation cANF⁴⁻²³, a selective NPR-C agonist (Maack *et al.*, 1987), and M372049, a selective NPR-C antagonist (Veale *et al.*, 2000) were used. HUVEC were incubated with cANF⁴⁻²³ (1 pM – 1 μ M) for 24 h, resulting in comparable peak increases in proliferation and a similar bi-phasic response to CNP (Figure 14). In the presence of M372049 (10 μ M; 30 min pre-incubation), the proliferative response to CNP (100 pM; 24 h) and cANF⁴⁻²³ (100 pM; 24 h) were significantly inhibited (Figure 15). M372049 (10 μ M) alone had no effect on proliferation (data not shown).

To confirm a role for NPR-C in the growth promoting effect of CNP, pulmonary microvascular endothelial cells (PMEC) were isolated from WT and NPR-C KO mice. The proliferative response elicited by CNP (100 pM; 24 h) was significantly lower in NPR-C KO PMEC in comparison to WT PMEC (Figure 16A). Moreover, basal proliferation in NPR-C KO PMEC was approximately 40 % compared to WT (Figure 16B).

Concentration-dependent effect of CNP and cANF⁴⁻²³ on HUVEC proliferation

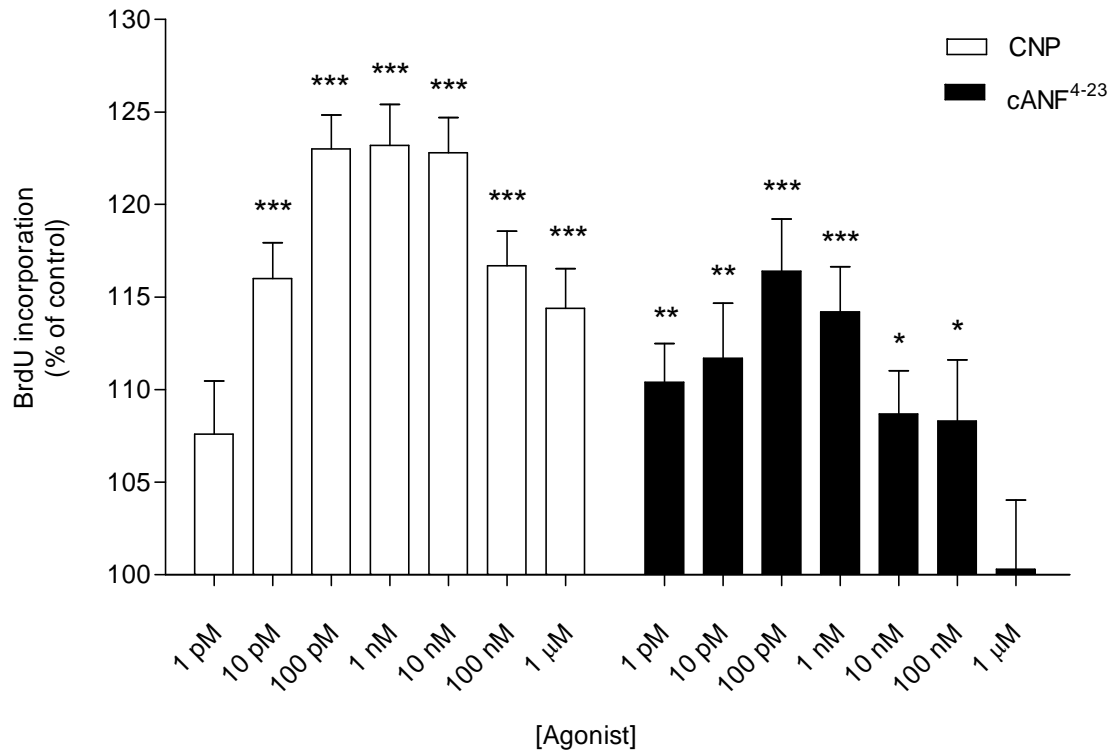

Figure 14 - BrdU incorporation in response to CNP (1 pM - 1μM) and cANF⁴⁻²³ (1 pM - 1μM; both 24 h) in HUVEC

Data are represented as mean ± SEM, expressed as a percentage of basal growth (control, set at 100 %); *P<0.05 vs control, **P<0.01 vs control, ***P<0.001 vs control; n=20 (CNP), n=4 (cANF⁴⁻²³), conducted in triplicate.

**Effect of CNP and cANF⁴⁻²³ on HUVEC proliferation
in the presence of M372049**

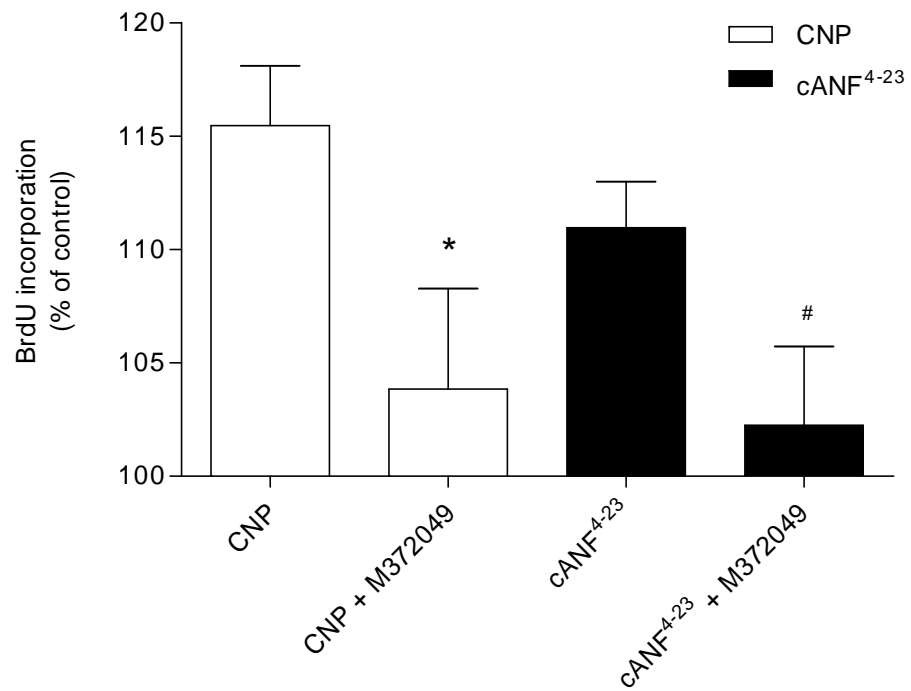

Figure 15 - BrdU incorporation in response to CNP (100 pM) and cANF⁴⁻²³ (100 pM; both 24 h) in HUVEC in the absence and presence of M372049 (10 μM)

Data are represented as mean ± SEM, expressed as a percentage of basal growth (control, set at 100 %);

*P<0.05 vs CNP alone, #P<0.01 vs cANF⁴⁻²³ alone; n=4-6, conducted in triplicate.

Effect of CNP on proliferation of WT and NPR-C KO PMEC

(A)

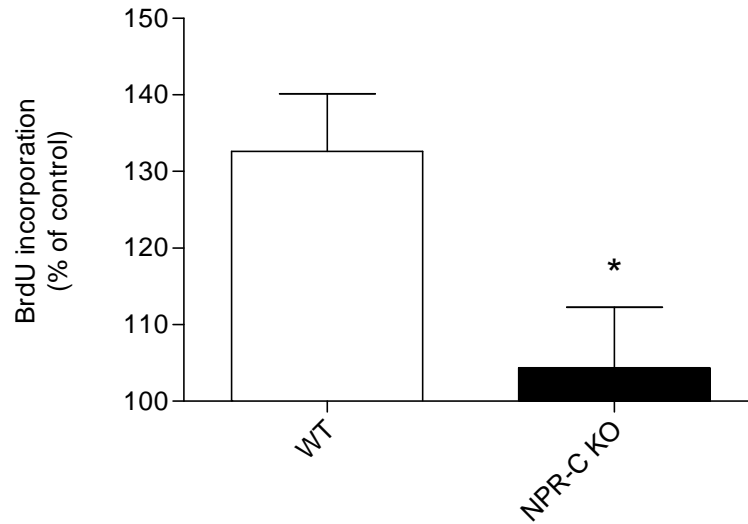

(B)

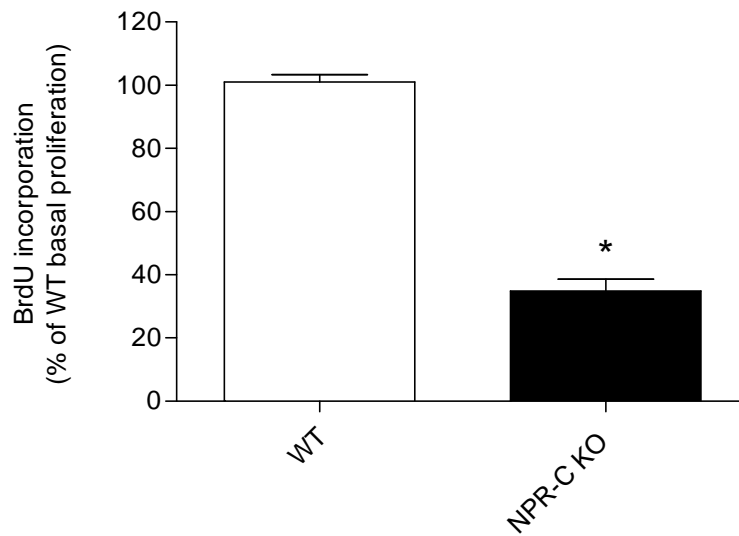

Figure 16 - BrdU incorporation in (A) CNP (100 pM; 24 h) treated and (B) non-treated PMEC

Data are represented as mean \pm SEM, expressed as a percentage of basal growth (control, set at 100 %);

* $P < 0.05$ vs WT; $n = 4$, conducted in triplicate.

3.4 Determination of the signalling pathway responsible for CNP-induced HUVEC proliferation

Having identified NPR-C as underlying CNP-induced endothelial cell proliferation, I attempted to identify the intracellular signalling pathway(s) involved. Work from our lab has shown that CNP-mediated inhibition of VSMC proliferation is in part via NPR-C activation and ERK 1/2 phosphorylation (Panayiotou, 2007). To determine if activation of a MAPK pathway is involved in CNP-mediated endothelial cell proliferation, HUVEC were treated with the ERK 1/2 inhibitor PD98059 (30 μ M), the p38 MAPK inhibitor SB203580 (30 μ M), and the JNK inhibitor SP600125 (3 μ M) for 30 min prior to addition of CNP (100 pM; 24 h). CNP-mediated endothelial cell proliferation was blocked significantly by pre-treatment with PD98059, whilst growth was unaffected in the presence of SB203580 or SP600125 (Figure 17).

A potential role for the PI3K/Akt pathway in CNP-induced HUVEC growth was also investigated since this signalling cascade is well established to regulate endothelial cell proliferation, particularly in response to VEGF (Brader and Eccles, 2004). HUVEC were treated with the structurally distinct PI3K inhibitors LY294002 (10 μ M) and wortmannin (500 nM) for 30 min prior to addition of CNP (100 pM; 24 h). Both LY294002 and wortmannin resulted in a significant reduction in CNP-induced proliferation (Figure 18).

Effect of MAPK inhibitors on CNP-induced HUVEC proliferation

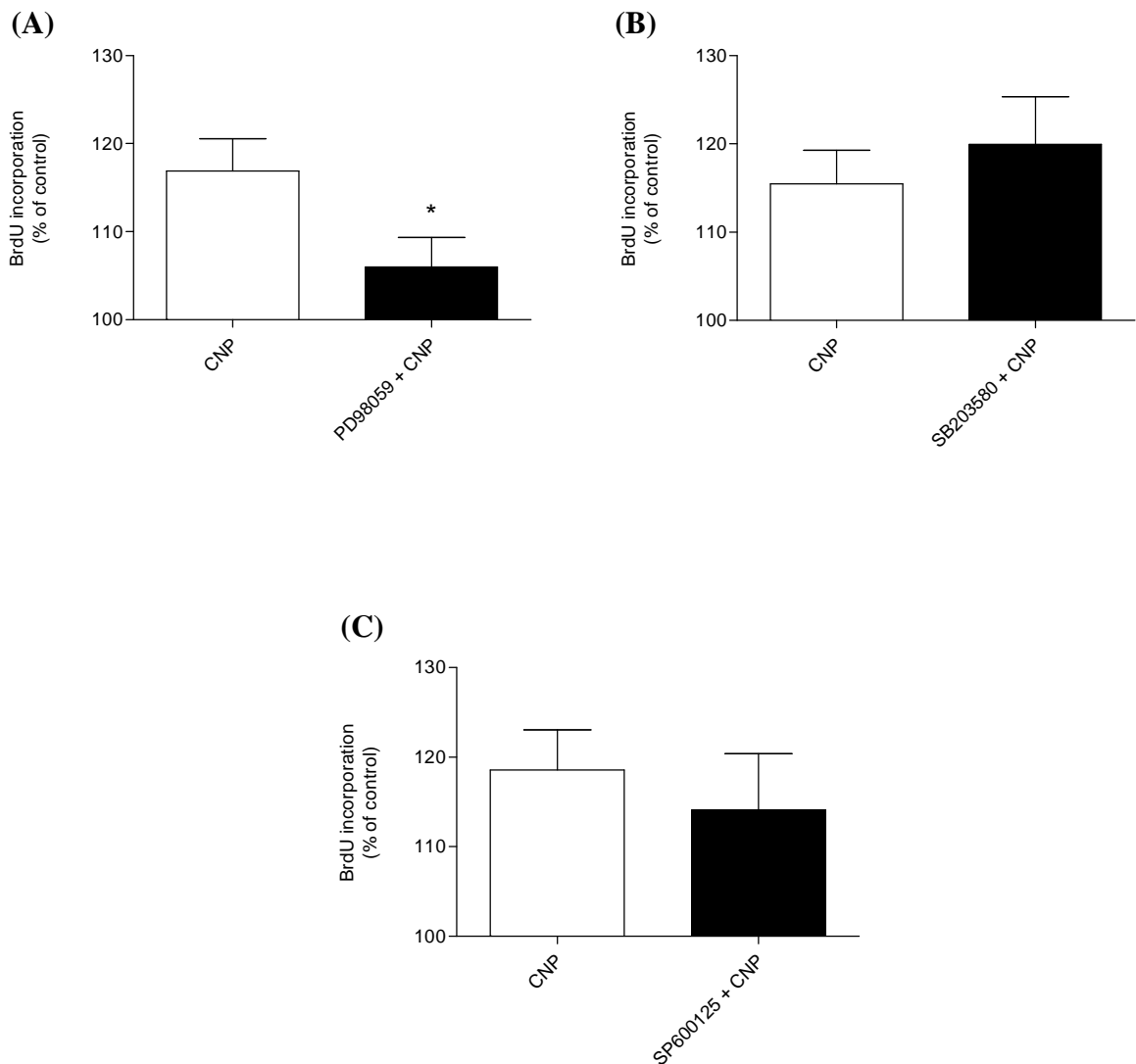
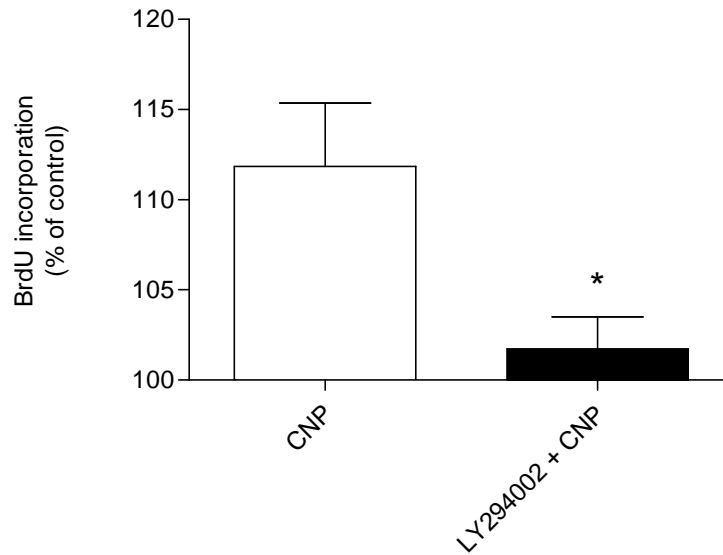

Figure 17 - BrdU incorporation in response to CNP (100 pM; 24 h) in HUVEC in the absence and presence of (A) PD98059 (30 μ M), (B) SB203580 (30 μ M) or (C) SP600125 (3 μ M)

Data are represented as mean \pm SEM, expressed as a percentage of basal growth (control, set at 100 % after excluding any effect of inhibitors alone PD98059, 69.07 \pm 1.76 %; SB203580, 113.41 \pm 3.70 %; SP600125, 88.84 \pm 2.61 %). *P<0.05 vs CNP; (A) n=7, (B) n=6, (C) n=3, conducted in triplicate.

Effect of PI3K inhibitors on CNP-induced HUVEC proliferation

(A)



(B)

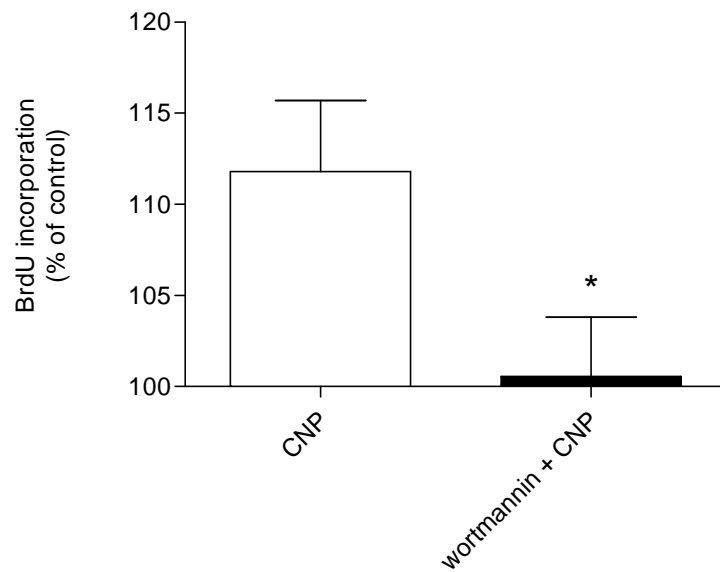

Figure 18 - BrdU incorporation in response to CNP (100 pM; 24h) in HUVEC in the absence and presence of (A) LY294002 (10 μ M), or (B) wortmannin (500 nM)

Data are represented as mean \pm SEM, expressed as a percentage of basal growth (control, set at 100 % after excluding any effect of inhibitors alone LY294002, 24.24 \pm 1.49 %; wortmannin, 86.11 \pm 2.19 %).

*P<0.05 vs CNP; n=4, conducted in triplicate.

3.5 CNP induces ERK 1/2 and Akt phosphorylation in HUVEC

Since the ERK 1/2 inhibitor, PD98059 attenuated CNP-induced HUVEC proliferation, total ERK 1/2 and phosphorylated ERK 1/2 protein levels were measured in response to CNP. HUVEC were treated with 100 pM CNP (0, 0.5, 1, 3, 6 and 24 h) and samples analysed by immunoblot. CNP elicited a rapid ERK 1/2 activation which was significant at 0.5 h, returning to basal level by 1 h (Figure 19). Total ERK 1/2 levels remained unaltered at all time points. VEGF (10 ng/ml) was used as a positive control since it has been shown to phosphorylate ERK 1/2 in HUVEC (Yu and Sato, 1999).

The PI3K inhibitors LY294002 and wortmannin also reduced CNP-mediated HUVEC proliferation, therefore total Akt and phosphorylated Akt were determined as described above. CNP elicited Akt phosphorylation which was significant at 0.5 h, whilst total Akt levels remained unaltered (Figure 20).

Effect of CNP on ERK 1/2 phosphorylation in HUVEC

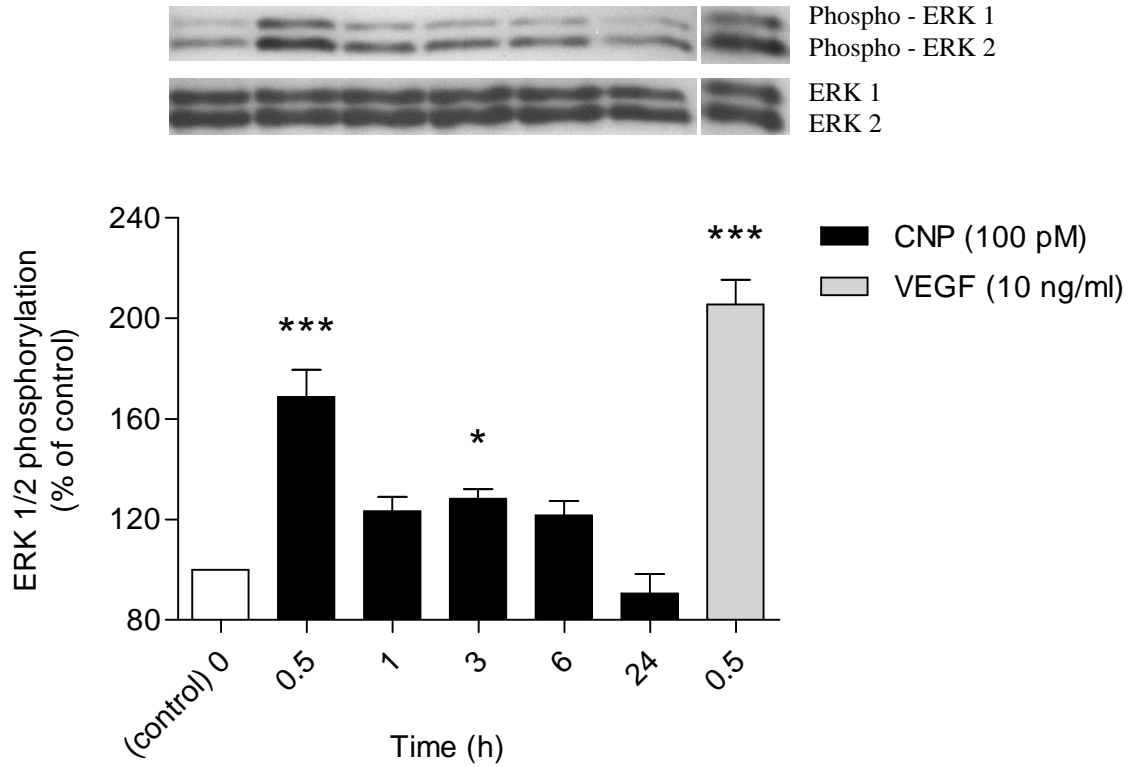

Figure 19 - Expression and phosphorylation of ERK 1/2 in response to CNP (100 pM) for 0 - 24 h in HUVEC

Expression and phosphorylation of ERK 1/2 was determined by western blotting and quantified by densitometry (normalised to control, 0 h). Data are represented as mean \pm SEM; * $P < 0.05$ vs control, *** $P < 0.001$ vs control; $n = 4$.

Effect of CNP on Akt phosphorylation in HUVEC

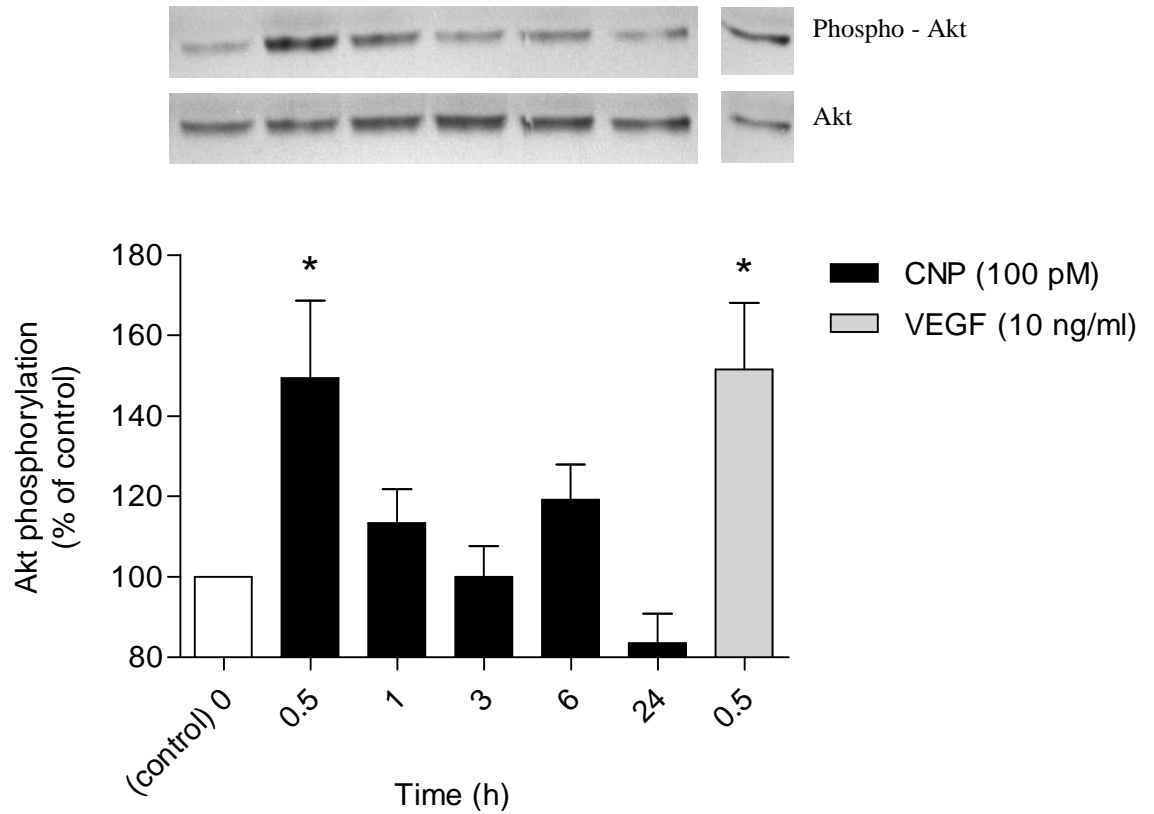

Figure 20 - Expression and phosphorylation of Akt in response to CNP (100 pM) for 0 - 24 h in HUVEC

Expression and phosphorylation of Akt was determined by western blotting and quantified by densitometry (normalised to control, 0 h). Data are represented as mean \pm SEM; *P<0.05 vs control; n=4.

3.6 NPR-C activation underlies CNP-induced ERK 1/2 and Akt phosphorylation in HUVEC

To confirm that NPR-C activation results in CNP-mediated ERK 1/2 and Akt phosphorylation, the NPR-C antagonist, M372049 and PTx, a $G_{i/o}$ G-protein inhibitor, were employed. PTx was used since NPR-C has been characterised to cause smooth muscle relaxation via a G_i -dependent mechanism (Chauhan *et al.*, 2003). HUVEC were pre-incubated with M372049 (10 μ M; 30 min) or PTx (100 ng/ml; 16 h) followed by treatment with CNP (100 pM; 30 min); 30 min was chosen since CNP significantly increases ERK 1/2 and Akt phosphorylation at this time point. M372049 and PTx blocked the CNP-elicited increase in ERK 1/2 (Figure 21 and Figure 22) and Akt (Figure 23 and Figure 24) phosphorylation. Total ERK 1/2 and Akt levels remained unaltered throughout.

Effect of M372049 on CNP-induced ERK 1/2 phosphorylation in HUVEC

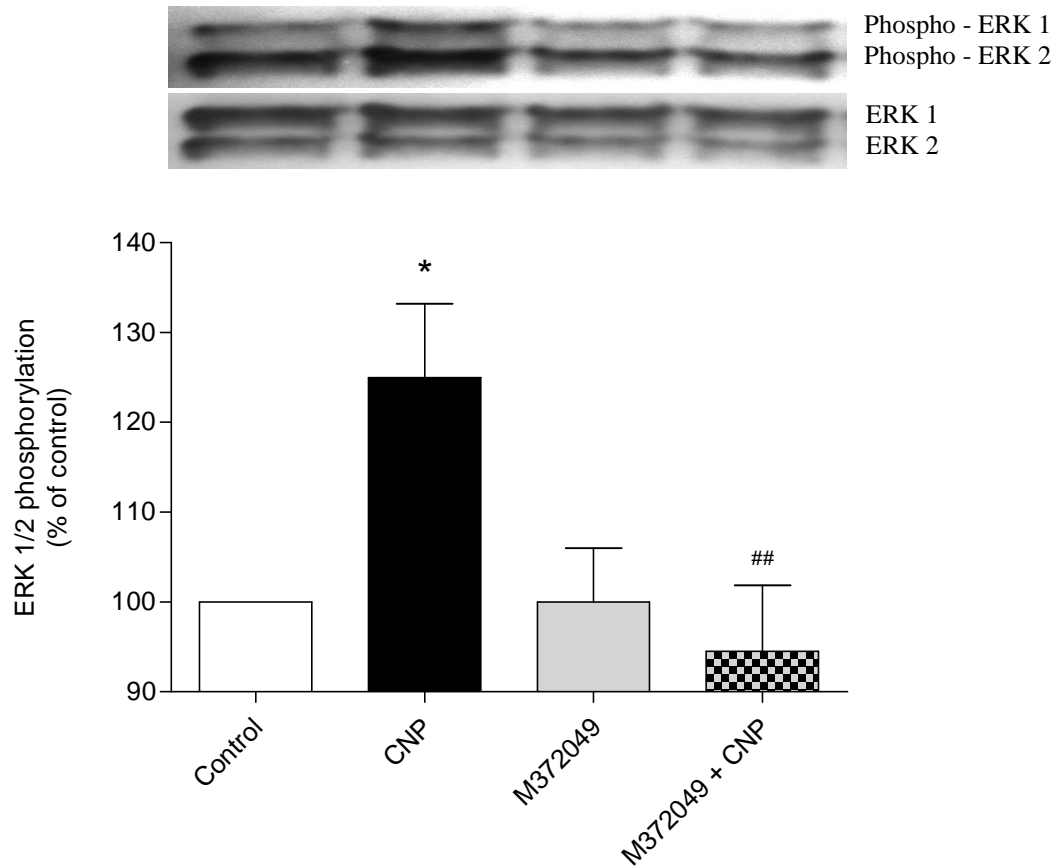

Figure 21 - Expression and phosphorylation of ERK 1/2 in response to CNP (100 pM; 30 min) in HUVEC in the absence and presence of M372049 (10 μ M)

Expression and phosphorylation of ERK 1/2 was determined by western blotting and quantified by densitometry (normalised to control). Data are represented as mean \pm SEM; *P<0.05 vs control, ##P<0.01 vs CNP; n=4.

Effect of *Pertussis toxin* on CNP-induced ERK 1/2 phosphorylation in HUVEC

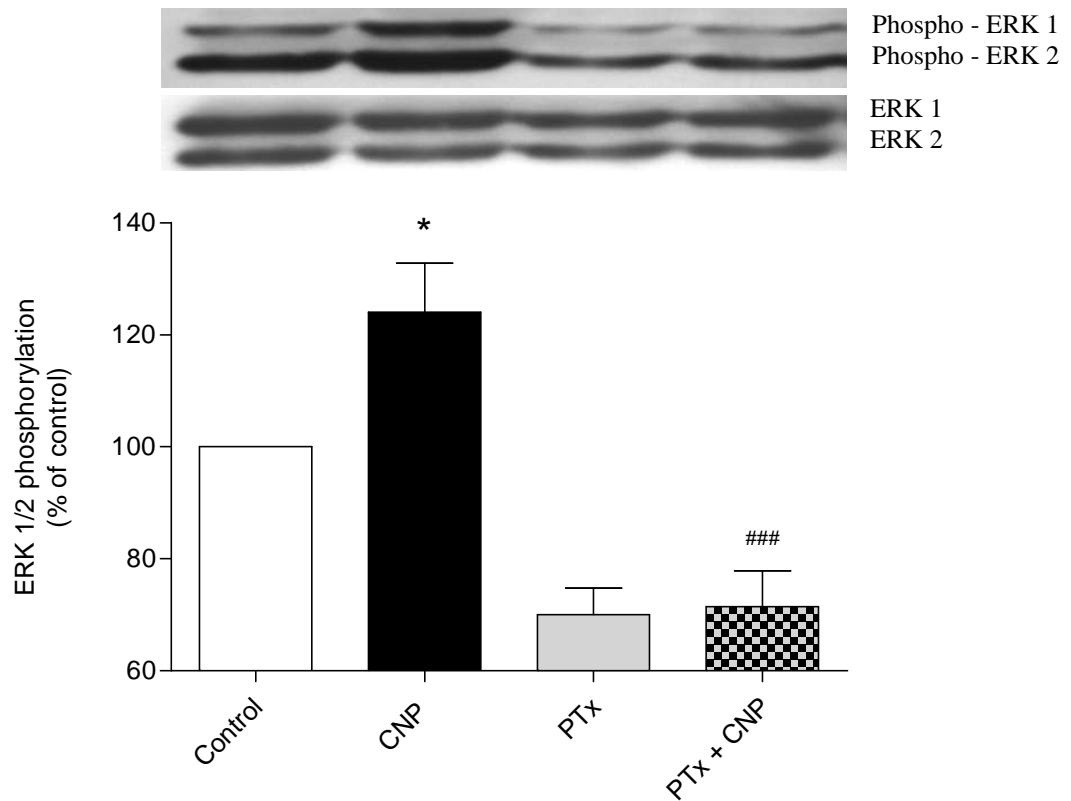

Figure 22 - Expression and phosphorylation of ERK 1/2 in response to CNP (100 μ M; 30 min) in HUVEC in the absence and presence of PTx (100 ng/ml)

Expression and phosphorylation of ERK 1/2 was determined by western blotting and quantified by densitometry (normalised to control). Data are represented as mean \pm SEM; * P <0.05 vs control, ### P <0.001 vs CNP, n =4.

Effect of M372049 on CNP-induced Akt phosphorylation in HUVEC

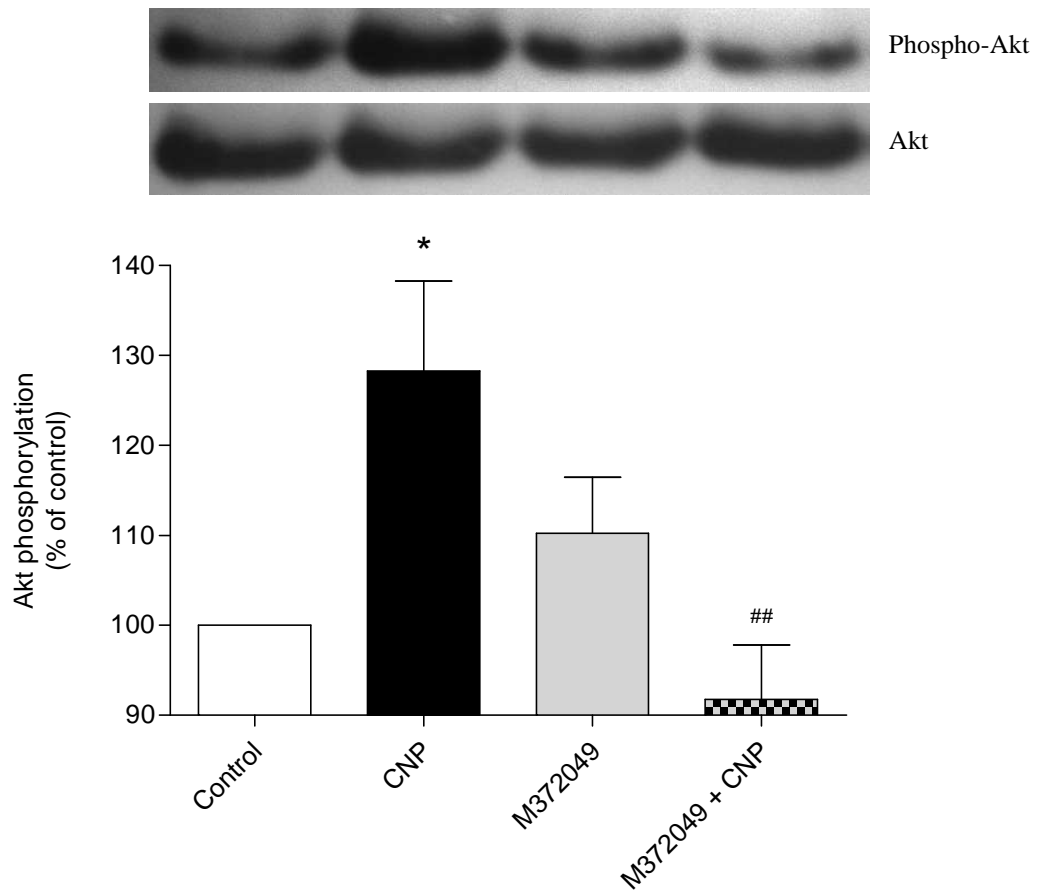

Figure 23 - Expression and phosphorylation of Akt in response to CNP (100 pM; 30 min) in HUVEC in the absence and presence of M372049 (10 μ M)

Expression and phosphorylation of Akt was determined by western blotting and quantified by densitometry (normalised to control). Data are represented as mean \pm SEM; *P<0.05 vs control, ##P<0.01 vs CNP; n=4.

Effect of *Pertussis toxin* on CNP-induced Akt phosphorylation in HUVEC

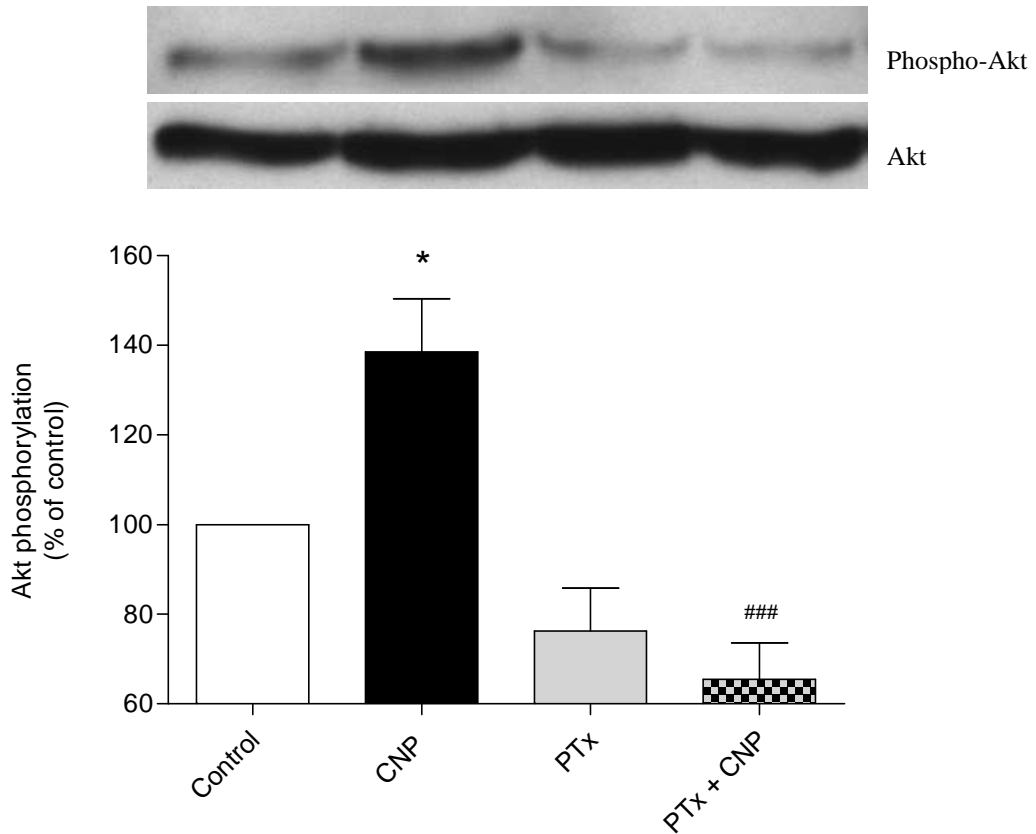

Figure 24 - Expression and phosphorylation of Akt in response to CNP (100 pM; 30 min) in HUVEC in the absence and presence of PTx (100 ng/ml)

Expression and phosphorylation of Akt was determined by western blotting and quantified by densitometry (normalised to control). Data are represented as mean \pm SEM; * $P < 0.05$ vs control, ### $P < 0.001$ vs CNP; $n = 4$.

3.7 CNP does not activate eNOS in HUVEC

VEGF has been shown to promote endothelial cell proliferation, in part, via NO production (Papapetropoulos *et al.*, 1997). eNOS, the source of NO in endothelial cells, can be phosphorylated at Ser1177 and activated by Akt (Fulton *et al.*, 1999). Since I have shown that Akt activity is triggered in response to CNP (Figure 20), I investigated if CNP-induced eNOS activation may provide a mechanism for the mitogenic effects of CNP in endothelial cells. Total and phosphorylated eNOS levels were assessed in HUVEC treated with CNP (100 pM; 30 min). However, CNP was unable to elicit eNOS phosphorylation (Figure 25).

Effect of CNP on eNOS phosphorylation in HUVEC

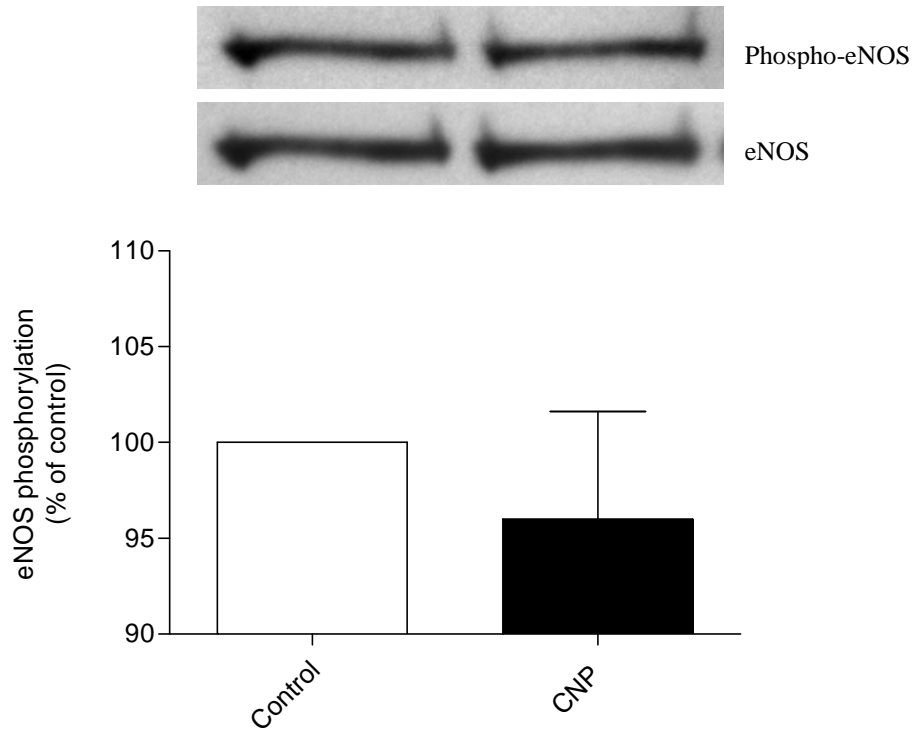

Figure 25 - Expression and phosphorylation of eNOS in HUVEC in response to CNP (100 pM; 30 min)

Expression and phosphorylation of eNOS was determined by western blotting and quantified by densitometry (normalised to control). Data are represented as mean \pm SEM; n=5.

3.8 CNP alters cell cycle protein expression in HUVEC in an ERK 1/2-dependent manner

I have previously shown CNP promotes HUVEC proliferation implying it alters cell cycle protein expression and activity. To investigate potential cell cycle protein targets, HUVEC were treated with 100 pM CNP (0, 0.5, 1, 3, 6 and 24 h) or VEGF (10 ng/ml; 6 h) and cyclin D1 (a cell cycle promoter) and p21^{waf1/cip1} (a cell cycle inhibitor) expression assessed. CNP caused a time dependent increase in cyclin D1 expression that was significant at 6 h, and returned to basal levels after 24 h (Figure 26). p21^{waf1/cip1} expression was significantly decreased at 24 h, but unaltered at shorter incubation times (Figure 27). VEGF was used as a positive control as it is a potent endothelial cell mitogen (Zachary, 2003); it did not significantly alter cyclin D1 expression (Figure 26) but decreased p21^{waf1/cip1} expression (Figure 27) to a similar magnitude as CNP.

Since I have demonstrated CNP promotes HUVEC proliferation via activation of the ERK 1/2 pathway (Figure 17), and that the ERK 1/2 pathway is a key regulator of the cell cycle (Meloche and Pouyssegur, 2007), the effect of inhibiting this MAPK pathway on cyclin D1 expression was investigated. HUVEC were pre-incubated with PD98059 (30 μ M; 30 min) followed by treatment with CNP (100 pM; 6 h). CNP increased cyclin D1 expression which was blocked by PD98059 (Figure 28).

Effect of CNP on cyclin D1 expression in HUVEC

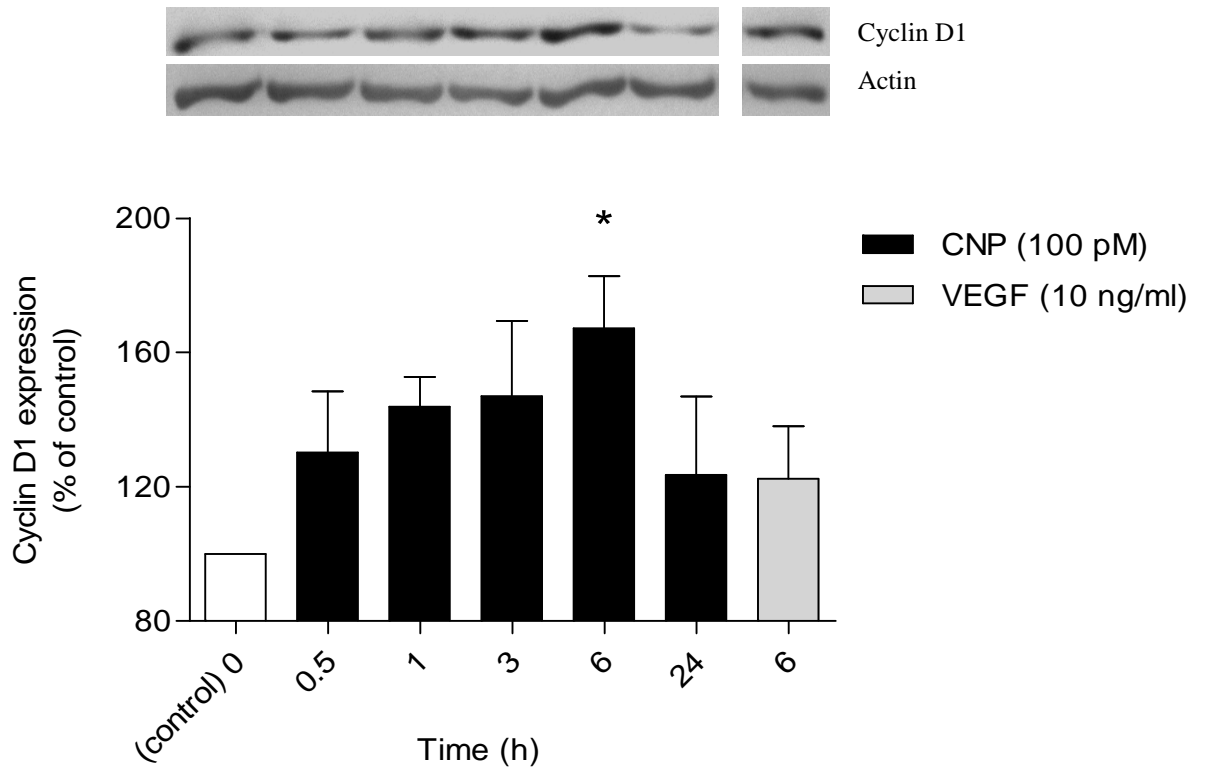

Figure 26 - Expression of cyclin D1 in response to CNP (100 pM) for 0 - 24 h in HUVEC

Cyclin D1 expression was determined by western blotting and quantified by densitometry (normalised to control, 0 h). Data are represented as mean \pm SEM; *P<0.05 vs control; n=4.

Effect of CNP on p21^{waf1/cip1} expression in HUVEC

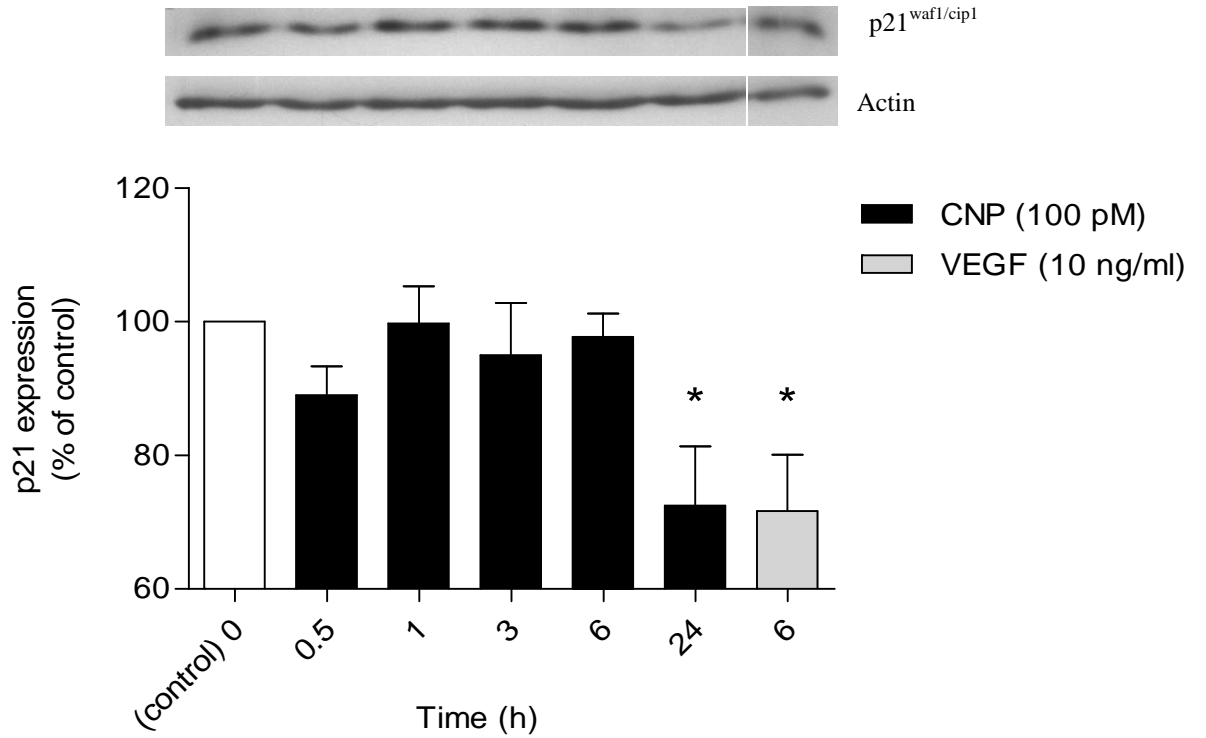

Figure 27 - Expression of p21^{waf1/cip1} in response to CNP (100 pM) for 0 - 24 h in HUVEC

p21^{waf1/cip1} expression was determined by western blotting and quantified by densitometry (normalised to control, 0 h). Data are represented as mean \pm SEM; *P<0.05 vs control; n=4.

Effect of PD98059 on CNP-induced cyclin D1 expression in HUVEC

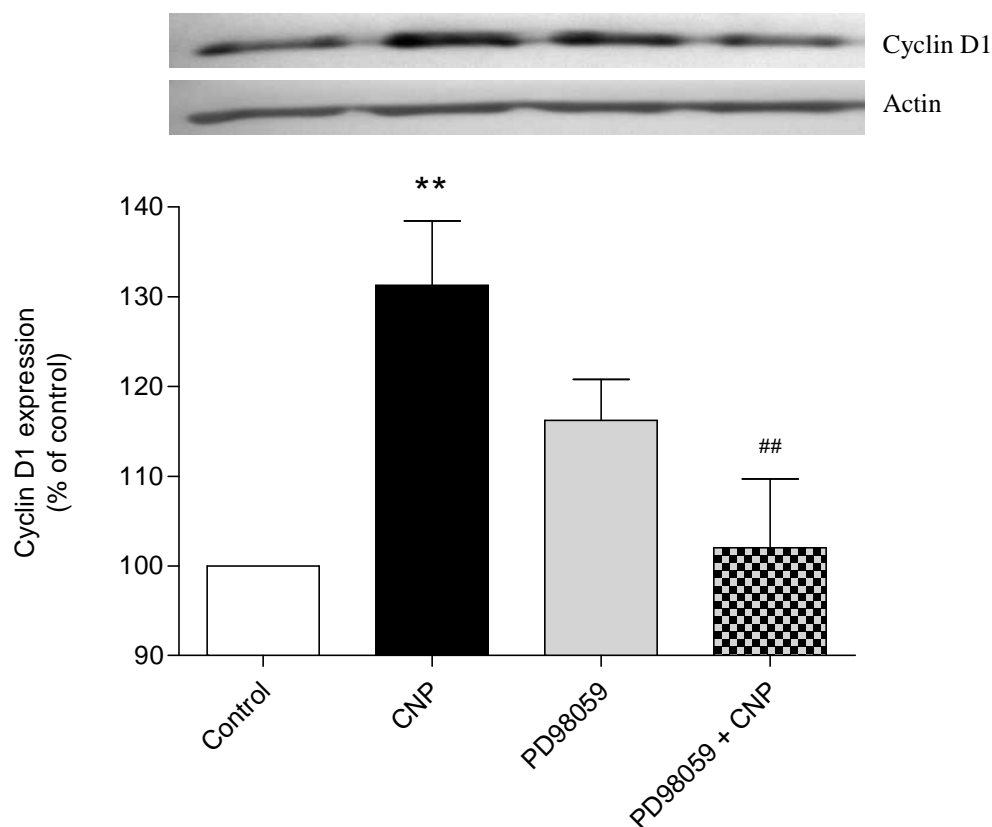

Figure 28 - Expression of cyclin D1 in response to CNP (100 pM; 24 h) in HUVEC in the absence or presence of PD98059 (30 μ M)

Cyclin D1 expression was determined by western blotting and quantified by densitometry (normalised to control). Data are represented as mean \pm SEM, expressed as cyclin D1 expression (percentage of control; set at 100 % excluding vehicle; DMSO 0.1 %, 116 \pm 6 %). **P<0.05 vs control, ##P<0.05 vs CNP, n=4.

3.9 CNP alters cell cycle protein expression in RAoSMC in an ERK 1/2-dependent manner

Since I had shown that CNP alters the expression of the cell cycle mediators cyclin D1 and p21^{waf1/cip1} in endothelial cells, it was investigated if CNP also differentially effects cell cycle proteins in VSMC, to bring about its anti-proliferative effects. This would potentially explain the differential effect of CNP on endothelial cell and smooth muscle cell growth, since CNP increases ERK 1/2 phosphorylation in both cell types (Panayiotou 2007; section 3.5). RAoSMC were treated with 1 μ M CNP (0, 0.5, 1, 3, 6 and 24 h) or Ang II (100 nM; 24 h). CNP elicited a time dependent increase in p21^{waf1/cip1} (Figure 29) and p27^{kip1} (Figure 30) expression which was significant at 6 and 24 h. CNP appeared to increase cyclin D1 expression, however this effect was not statistically significant (Figure 31). Ang II was used as a positive control as it is a well established promoter of smooth muscle cell proliferation (Wolf and Wenzel, 2004); it significantly increased p21^{waf1/cip1} (Figure 29) but had no significant effect on p27^{kip1} (Figure 30) or cyclin D1 expression (Figure 31).

In order to link CNP-induced ERK 1/2 phosphorylation in RAoSMC with downstream effects on cell cycle proteins, RAoSMC were pre-incubated with PD98059 (30 μ M; 30 min) followed by treatment with CNP (1 μ M; 24 h). Pre-incubation with PD98059 blocked the CNP mediated increase in p21^{waf1/cip1} (Figure 32) and p27^{kip1} (Figure 33).

Effect of CNP on p21^{waf1/cip1} expression in RAoSMC

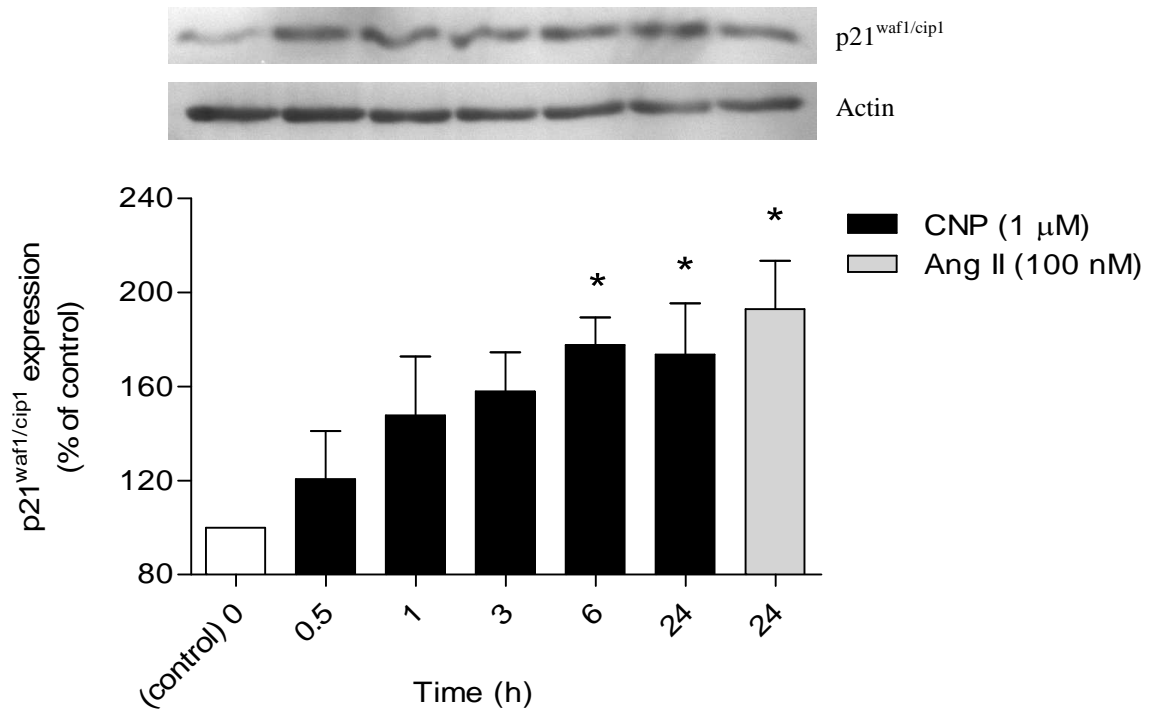

Figure 29 - Expression of p21^{waf1/cip1} in response to CNP (1 μM) for 0 - 24 h in RAoSMC

p21^{waf1/cip1} expression was determined by western blotting and quantified by densitometry (normalised to control, 0 h). Data are represented as mean ± SEM; *P<0.05 vs control; n=3.

Effect of CNP on p27^{kip1} expression in RAoSMC

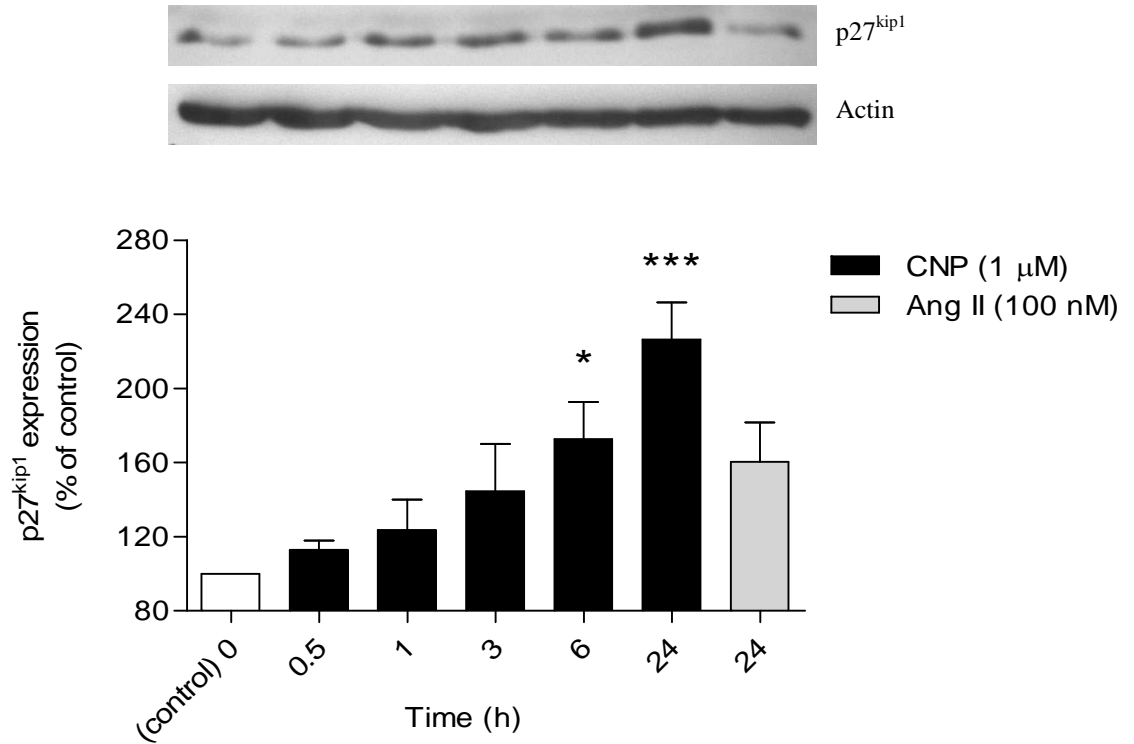

Figure 30 - Expression of p27^{kip1} in response to CNP (1 μM) for 0 - 24 h in RAoSMC

p27^{kip1} expression was determined by western blotting and quantified by densitometry (normalised to control, 0 h). Data are represented as mean ± SEM; *P<0.05 vs control, *** P<0.001 vs control; n=3.

Effect of CNP on cyclin D1 expression in RAoSMC

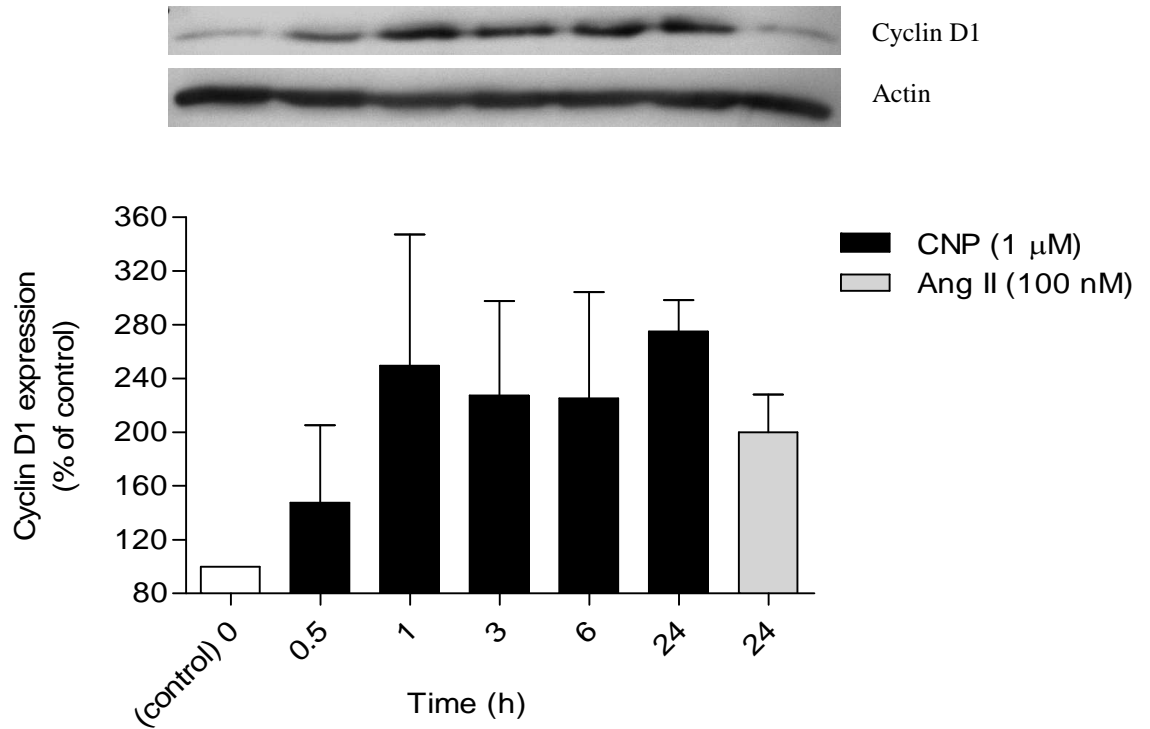

Figure 31 - Expression of cyclin D1 in response to CNP (1 μ M) for 0 - 24 h in RAoSMC

Cyclin D1 expression was determined by western blotting and quantified by densitometry (normalised to control, 0 h). Data are represented as mean \pm SEM; n=3.

Effect of PD98059 on CNP-induced p21^{waf1/cip1} expression in RAoSMC

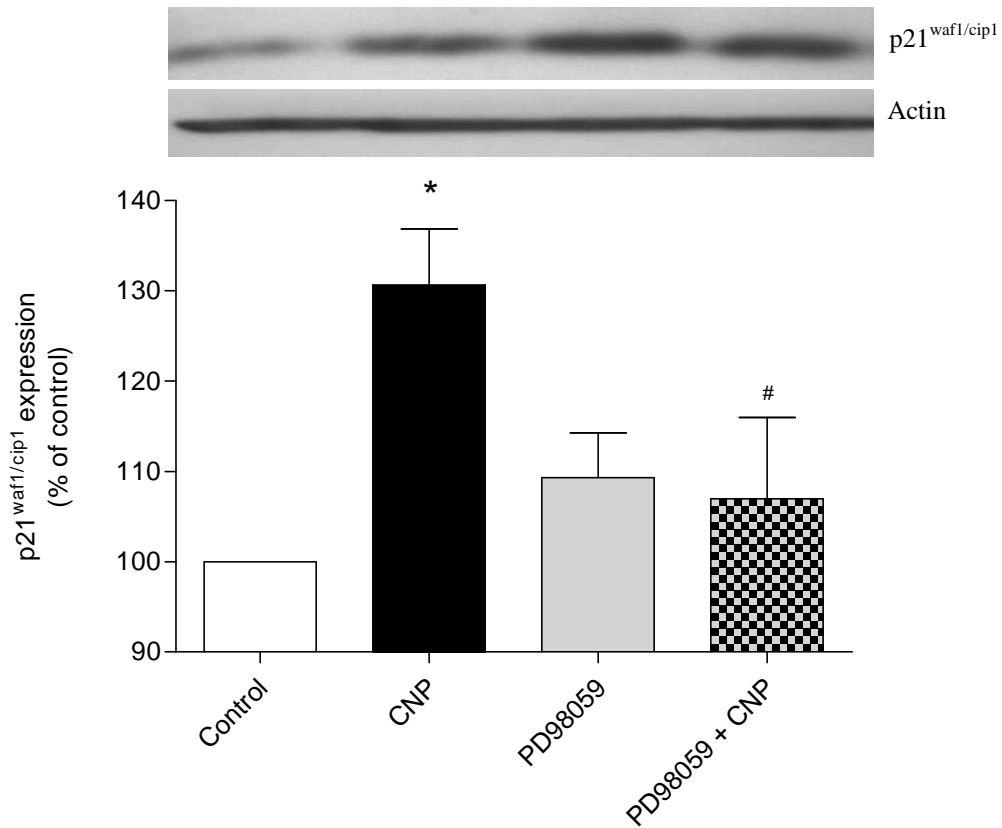

Figure 32 - Expression of p21^{waf1/cip1} in response to CNP (1 μ M; 24 h) in RAoSMC in the absence or presence of PD98059 (30 μ M)

p21^{waf1/cip1} expression was determined by western blotting and quantified by densitometry (normalised to control). Data are represented as mean \pm SEM, expressed as p21^{waf1/cip1} expression (percentage of control; set at 100 % excluding vehicle; DMSO 0.1 %, 160 \pm 16 %). *P<0.05 vs control, #P<0.05 vs CNP, n=3.

Effect of PD98059 on CNP-induced p27^{kip1} expression in RAoSMC

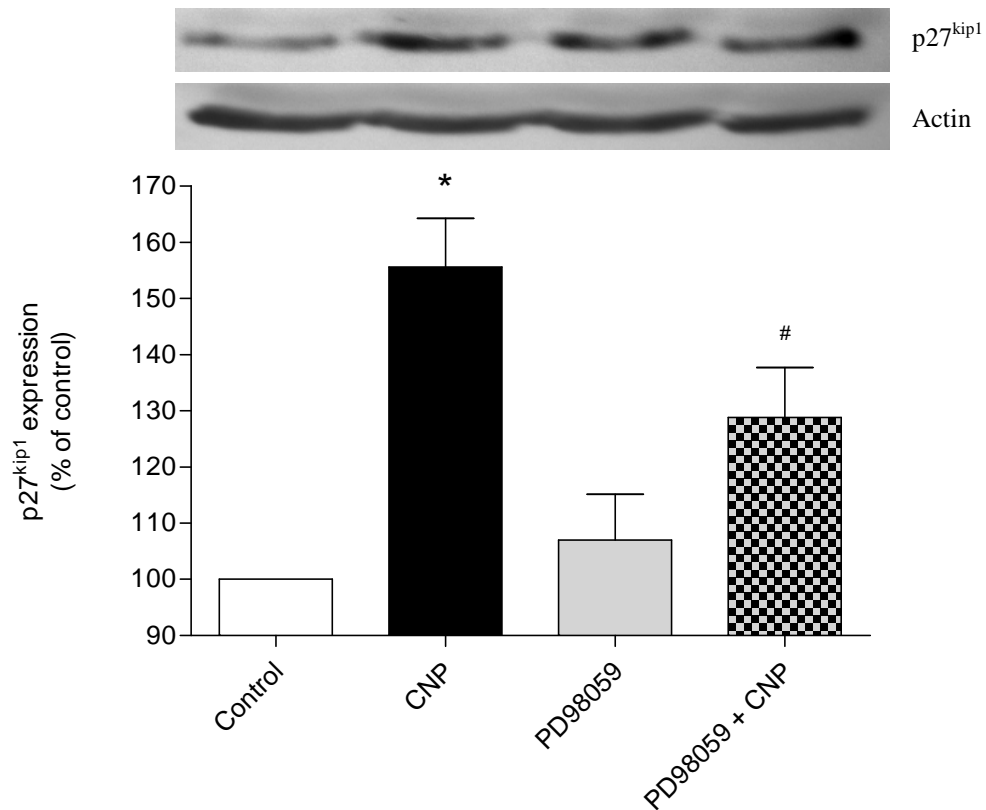

Figure 33 - Expression of p27^{kip1} in response to CNP (1 μ M; 24 h) in RAoSMC in the absence or presence of PD98059 (30 μ M)

p27^{kip1} expression was determined by western blotting and quantified by densitometry (normalised to control). Data are represented as mean \pm SEM, expressed as p27^{kip1} expression (percentage of control; set at 100 % excluding vehicle; DMSO 0.1 %, 149 \pm 3 %). *P<0.05 vs control, #P<0.05 vs CNP; n=5.

3.10 Summary of key findings

I have shown that CNP promotes endothelial cell proliferation in an NPR-C dependent manner. In turn, NPR-C activation leads to an increase in ERK 1/2 and Akt activation which results in the former augmenting cyclin D1 expression and facilitating cell cycle progression. In VSMC, CNP elicits an ERK 1/2-dependent increase of p21^{waf1/cip1} and p27^{kip1} expression, thereby preventing cell cycle progression and proliferation. Thus, I have identified a key differential effect of CNP-dependent ERK 1/2 phosphorylation, via NPR-C, in endothelial cells and VSMC that appears to underlie the pro- and anti-mitogenic effects of CNP, in these two cell types.

Chapter 4

Results 2

4 Results 2

4.1 Introduction

CNP is a vasodilator of conduit (Drewett *et al.*, 1995; Wennberg *et al.*, 1999; Madhani *et al.*, 2003) and resistance arteries (Chauhan *et al.*, 2003; Villar *et al.*, 2007; Kun *et al.*, 2008) and recent studies have suggested CNP to be an EDHF (Chauhan *et al.*, 2003; Villar *et al.*, 2007). In addition, CNP administration to healthy humans, monkeys, dogs and rats elicits a transient reduction in blood pressure (Clavell *et al.*, 1993; Igaki *et al.*, 1996; Seymour *et al.*, 1996; Aizawa *et al.*, 2008). Such observations intimate that CNP may be important in regulation of local blood flow and systemic blood pressure. In order to determine the role of endothelium-derived CNP, in cardiovascular homeostasis, our lab has developed an endothelial cell CNP KO (ecCNP KO) mouse. This is to circumvent the problems in global CNP KO mice, which includes gross bone deformation and less than 30 % of these animals survive up to the age of 16 weeks (Komatsu *et al.*, 2002).

Studies described in this chapter investigate the hypothesis that ecCNP KO mice have altered vascular and endothelial function and are hypertensive. This was achieved by assessing thoracic aorta and mesenteric artery reactivity, *in vitro*, and measuring mean arterial blood pressure (MABP) *in vivo* using radiotelemetry.

4.2 Initial characterisation of WT and ecCNP KO mice

To determine the genotype of animals, PCR was carried out on DNA isolated from ear clip samples. Animals that express a homozygote floxed CNP gene and express Tie2 are deemed ecCNP KO animals (refer to section 2.8.1 for ecCNP KO generation). Throughout this chapter, four genotypes have been studied: $Nppc^{+/+} Tie2^{-}$, $Nppc^{+/+} Tie2^{+}$, $Nppc^{flox/flox} Tie2^{-}$ and $Nppc^{flox/flox} Tie2^{+}$ (ecCNP KO). Data shown as WT is the grouped data for $Nppc^{+/+} Tie2^{-}$, $Nppc^{+/+} Tie2^{+}$ and $Nppc^{flox/flox} Tie2^{-}$ animals. Figure 34 depicts all the genotypes produced by the $Nppc^{flox/+} Tie2^{+}$ breeding pairs. Littermate controls were used throughout.

To assess if ecCNP KO mice exhibit altered growth rates, animals were weighed weekly from age 6 to 16 weeks. Increase in body weights were unchanged in male (Figure 35) and female (Figure 37) ecCNP KO mice when compared to WT. Change in body mass from 6 to 16 weeks was also unaltered in male (Figure 36) and female (Figure 38) ecCNP KO mice versus WT.

Genotyping of WT and ecCNP KO mice

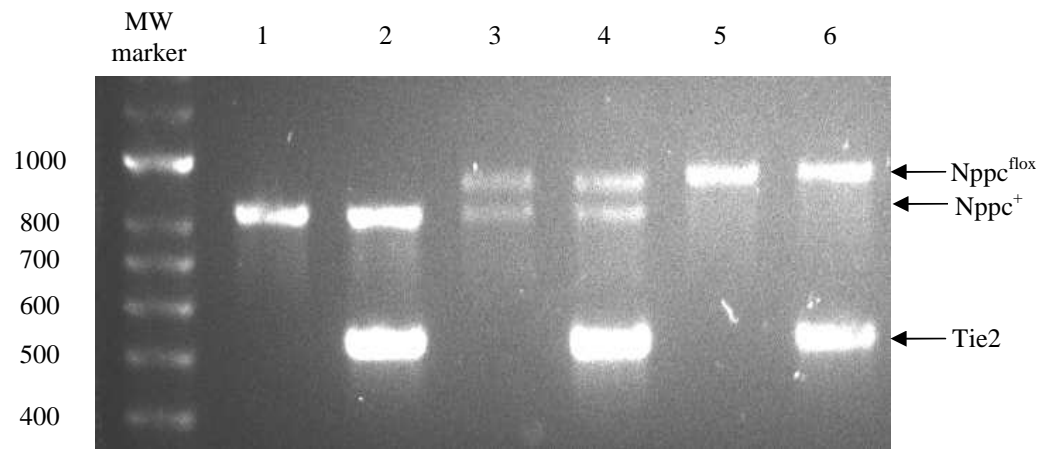

Figure 34 - Genotyping of WT and ecCNP KO mice

Gel depicting the 6 possible offspring from $Nppc^{flox/+}$ $Tie2^+$ breeders. Lane (1) $Nppc^{+/+}$ $Tie2^-$, (2) $Nppc^{+/+}$ $Tie2^+$, (3) $Nppc^{flox/+}$ $Tie2^-$, (4) $Nppc^{flox/+}$ $Tie2^+$, (5) $Nppc^{flox/flox}$ $Tie2^-$ and (6) $Nppc^{flox/flox}$ $Tie2^+$ (ecCNP KO)

**Body mass of male WT and ecCNP KO mice
aged 6 to 16 weeks old**

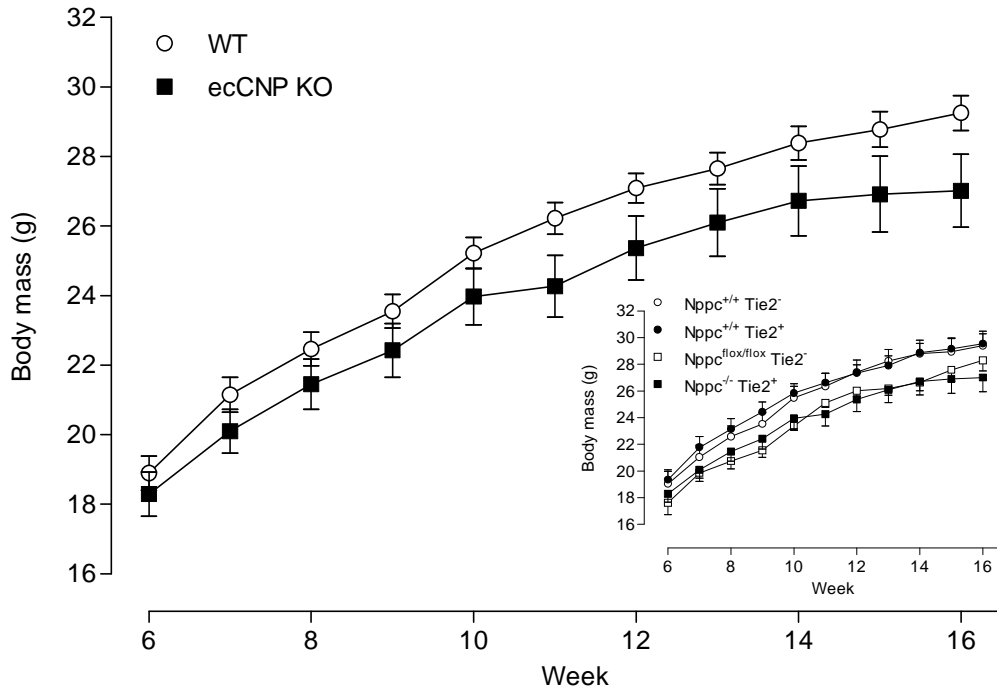

Figure 35 - Body mass of male WT and ecCNP KO mice aged 6 to 16 weeks old

Data are represented as mean \pm SEM; n=7-16.

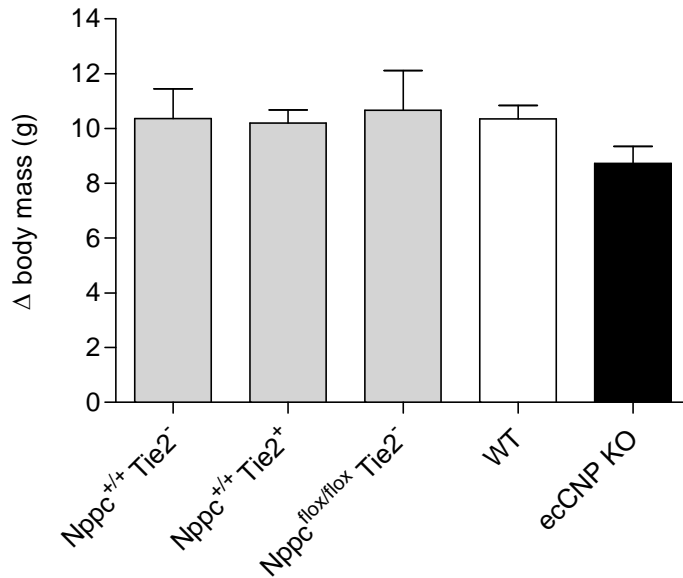

Figure 36 - Body mass change in male WT and ecCNP KO mice between 6 and 16 weeks old

Data are represented as mean \pm SEM; n=7-16.

**Body mass of female WT and ecCNP KO mice
aged 6 to 16 weeks old**

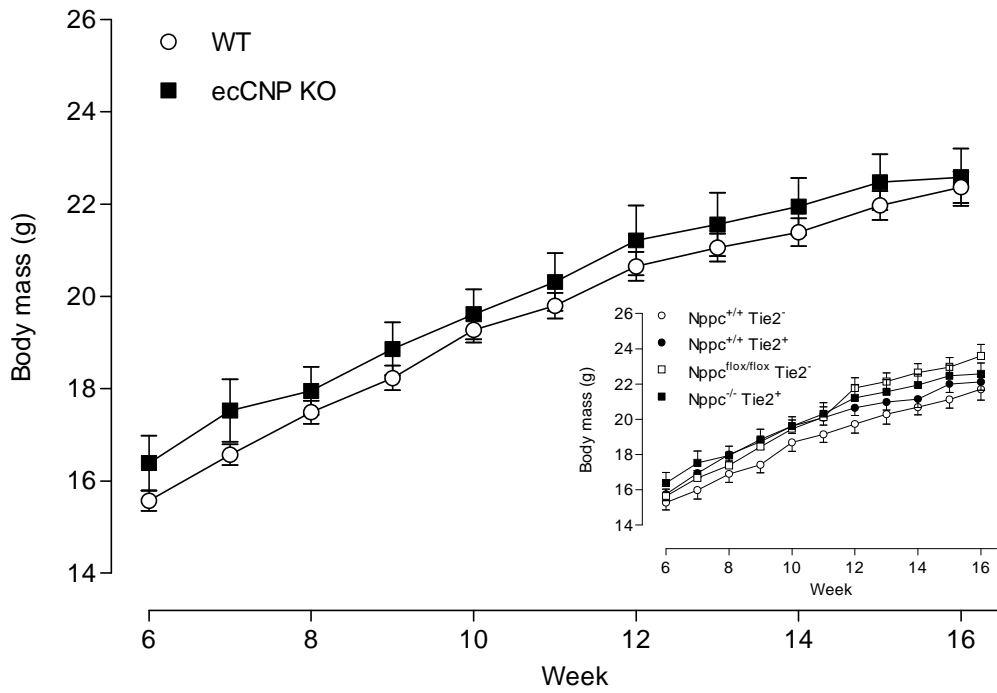

Figure 37 - Body mass of female WT and ecCNP KO mice aged 6 to 16 weeks old

Data are represented as mean \pm SEM; n=8-13.

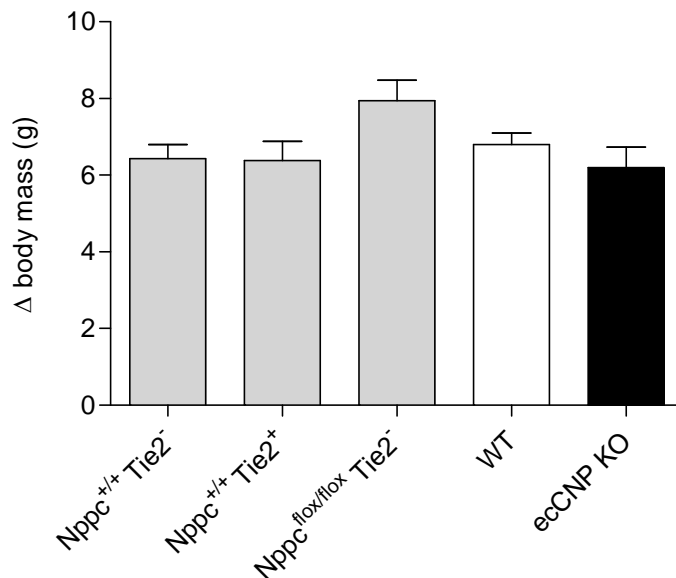

Figure 38 - Body mass change in female WT and ecCNP KO mice aged 6 to 16 weeks old

Data are represented as mean \pm SEM; n=8-13.

4.3 Effect of endothelial CNP gene knockout on functional reactivity of thoracic aorta

Functional pharmacological studies were used to determine thoracic aorta reactivity. Concentration-response curves were constructed for the contractile agents PE and U46619 and for the relaxant agents ACh (endothelium-dependent), CNP and Sper-NO (both endothelium-independent). In order to construct relaxant concentration-response curves, vessels were pre-contracted with an EC_{80} concentration of PE.

4.3.1 Contractile agonists

Vascular responsiveness to PE was unchanged in male (Figure 39) and female (Figure 40) ecCNP KO mice versus WT. Contractile responses to U46619 were also unchanged in both sexes (Figure 41 and Figure 42).

4.3.2 Vasorelaxants

In male ecCNP KO mice, the response to ACh was unchanged compared to WT (Figure 43). ecCNP KO female aortae exhibited a significantly reduced potency to ACh with a lower E_{max} (72.56 ± 1.96 and 64.44 ± 3.53 ; WT and ecCNP KO, respectively), although the EC_{50} was unaltered (Figure 44).

ecCNP KO male aortae demonstrated a statistically significant leftward shift in the CNP concentration-response curve, versus WT (Figure 45). However, the EC_{50} and E_{max} were unchanged. Female ecCNP KO aortae exhibited unaltered responsiveness to CNP, compared to WT (Figure 46).

In males, the concentration response curves to Sper-NO were indistinguishable between WT and ecCNP KO (Figure 47), although there was a minor change in the EC_{50} (pEC_{50} : 6.65 ± 0.04 and 6.80 ± 0.03 ; WT and ecCNP KO, respectively). ecCNP KO female aortae demonstrated a leftward shift in the concentration-response curve to Sper-NO (Figure 48) with an increase in potency (pEC_{50} : 6.48 ± 0.04 and 6.75 ± 0.08 ; WT and ecCNP KO, respectively); the E_{max} was unaltered.

Effect of PE in aortic rings from male WT and ecCNP KO mice

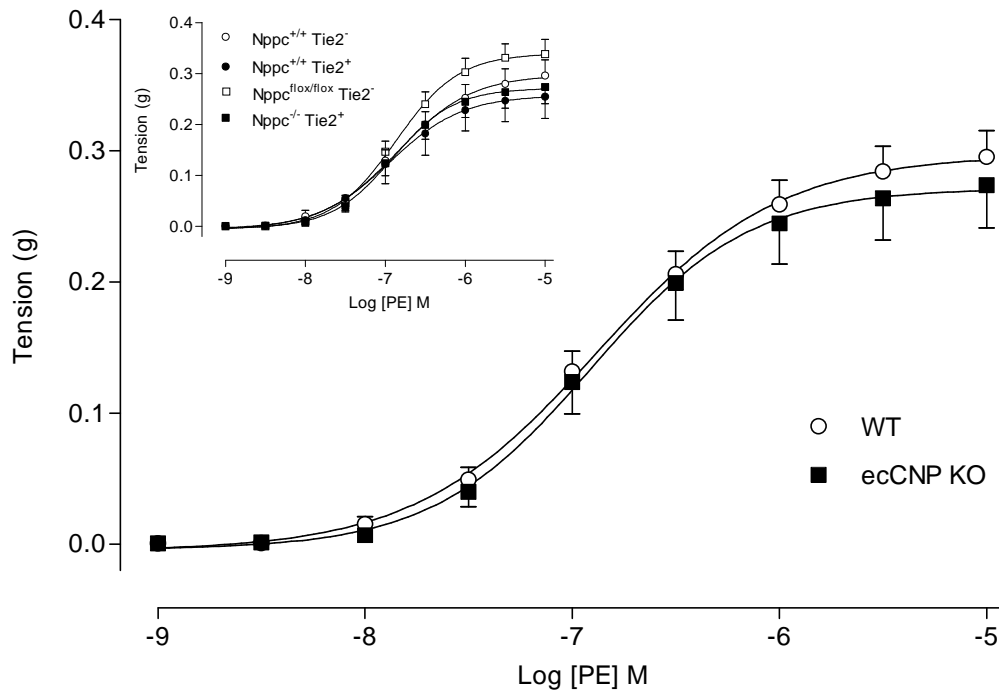

Figure 39 - Concentration-response curves to PE in aortic rings from male WT and ecCNP KO mice

Inset graph shows concentration-response curves to PE in male aortic rings from individual genotypes. Contraction is expressed as mean \pm SEM increase in tension (g); n=7-9.

	PE pEC ₅₀ -log [M]	PE E _{max} tension (g)
Nppc ^{+/+} Tie2 ⁻	6.85 \pm 0.13	0.30 \pm 0.03
Nppc ^{+/+} Tie2 ⁺	6.95 \pm 0.22	0.25 \pm 0.04
Nppc ^{flox/flox} Tie2 ⁻	6.87 \pm 0.09	0.34 \pm 0.03
WT	6.88 \pm 0.08	0.30 \pm 0.02
ecCNP KO	6.91 \pm 0.12	0.27 \pm 0.03

Table 3 - pEC₅₀ and E_{max} values of PE in aortic rings from male WT and ecCNP KO mice

pEC₅₀ is expressed as mean \pm SEM -log [M]. E_{max} is expressed as mean \pm SEM increase in tension (g); n=7-9.

Effect of PE in aortic rings from female WT and ecCNP KO mice

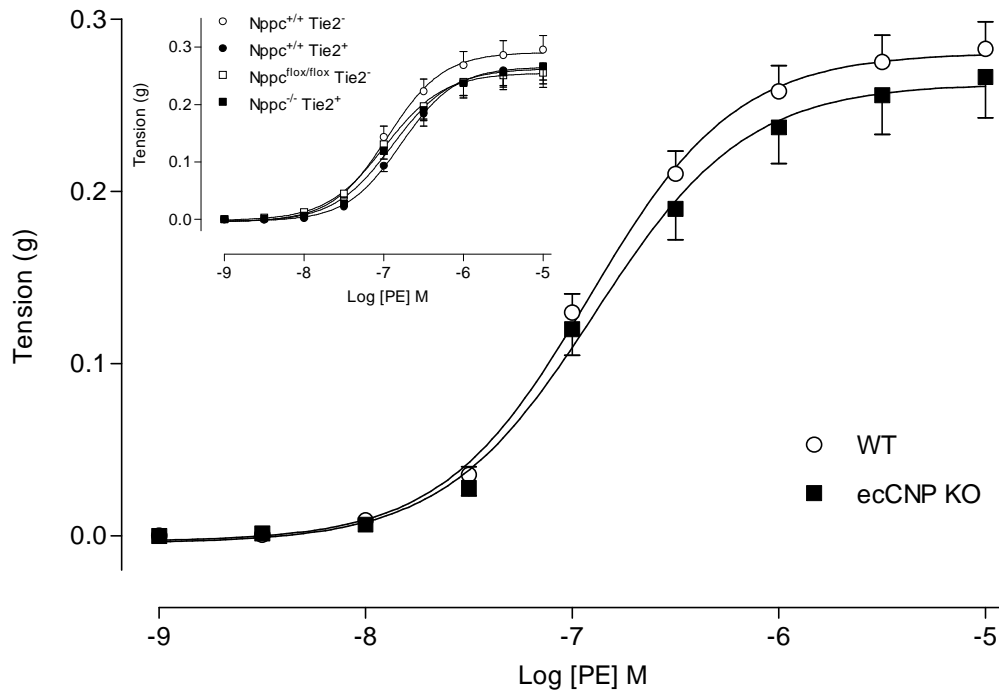

Figure 40 - Concentration-response curves to PE in aortic rings from female WT and ecCNP KO mice

Inset graph shows concentration-response curves to PE in female aortic rings from individual genotypes. Contraction is expressed as mean \pm SEM increase in tension (g); n=8-11.

	PE pEC ₅₀ -log [M]	PE E _{max} tension (g)
Nppc ^{+/+} Tie2 ⁻	6.95 \pm 0.08	0.30 \pm 0.03
Nppc ^{+/+} Tie2 ⁺	6.79 \pm 0.09	0.27 \pm 0.03
Nppc ^{flox/flox} Tie2 ⁻	6.99 \pm 0.10	0.26 \pm 0.03
WT	6.92 \pm 0.05	0.28 \pm 0.02
ecCNP KO	6.89 \pm 0.08	0.27 \pm 0.02

Table 4 - pEC₅₀ and E_{max} values of PE in aortic rings from female WT and ecCNP KO mice

pEC₅₀ is expressed as mean \pm SEM -log [M]. E_{max} is expressed as mean \pm SEM increase in tension (g); n=8-11.

Effect of U46619 in aortic rings from male WT and ecCNP KO mice

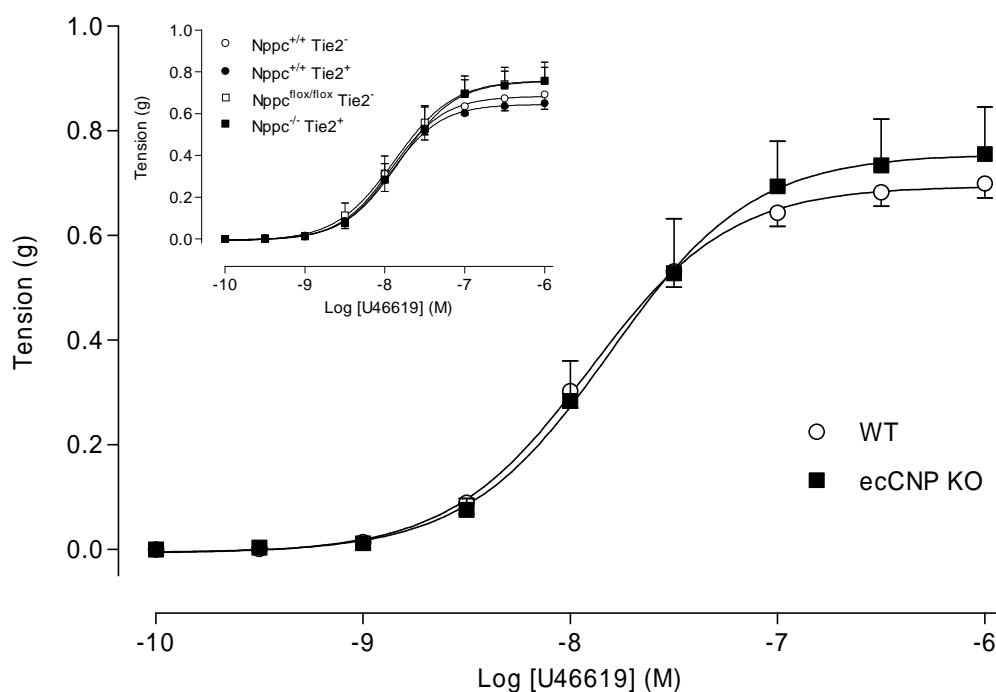

Figure 41 - Concentration-response curves to U46619 in aortic rings from male WT and ecCNP KO mice

Inset graph shows concentration-response curves to U46619 in male aortic rings from individual genotypes. Contraction is expressed as mean \pm SEM increase in tension (g); n=5-6.

	U46619 pEC ₅₀ -log [M]	U46619 E _{max} tension (g)
Nppc ^{+/+} Tie2 ⁻	7.92 \pm 0.06	0.69 \pm 0.04
Nppc ^{+/+} Tie2 ⁺	7.93 \pm 0.05	0.65 \pm 0.03
Nppc ^{flox/flox} Tie2 ⁻	7.88 \pm 0.10	0.76 \pm 0.06
WT	7.90 \pm 0.04	0.70 \pm 0.03
ecCNP KO	7.81 \pm 0.11	0.76 \pm 0.09

Table 5 - pEC₅₀ and E_{max} values of U46619 in aortic rings from male WT and ecCNP KO mice
pEC₅₀ is expressed as mean \pm SEM -log [M]. E_{max} is expressed as mean \pm SEM increase in tension (g); n=5-6.

Effect of U46619 in aortic rings from female WT and ecCNP KO mice

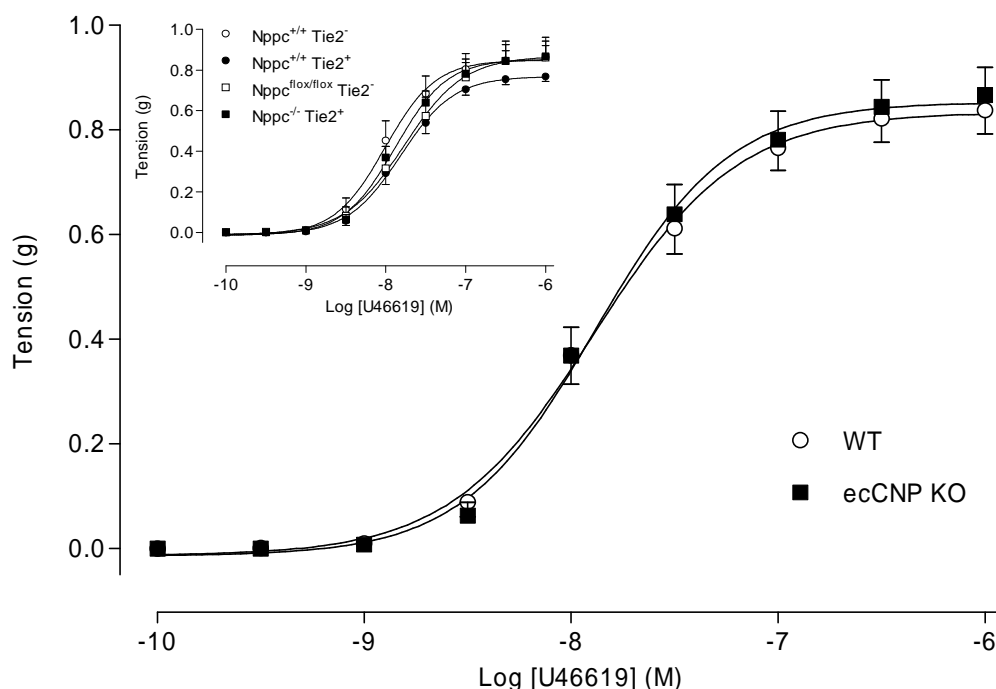

Figure 42 - Concentration-response curves to U46619 in aortic rings from female WT and ecCNP KO mice

Inset graph shows concentration-response curves to U46619 in female aortic rings from individual genotypes. Contraction is expressed as mean \pm SEM increase in tension (g); n=5-8.

	U46619 pEC ₅₀ -log [M]	U46619 E _{max} tension (g)
Nppc ^{+/+} Tie2 ⁻	8.01 \pm 0.09	0.86 \pm 0.08
Nppc ^{+/+} Tie2 ⁺	7.81 \pm 0.05	0.77 \pm 0.02
Nppc ^{flox/flox} Tie2 ⁻	7.77 \pm 0.12	0.86 \pm 0.10
WT	7.89 \pm 0.06	0.84 \pm 0.05
ecCNP KO	7.88 \pm 0.06	0.87 \pm 0.05

Table 6 - pEC₅₀ and E_{max} values of U46619 in aortic rings from female WT and ecCNP KO mice
pEC₅₀ is expressed as mean \pm SEM -log [M]. E_{max} is expressed as mean \pm SEM increase in tension (g); n=5-8.

Effect of ACh in aortic rings from male

WT and ecCNP KO mice

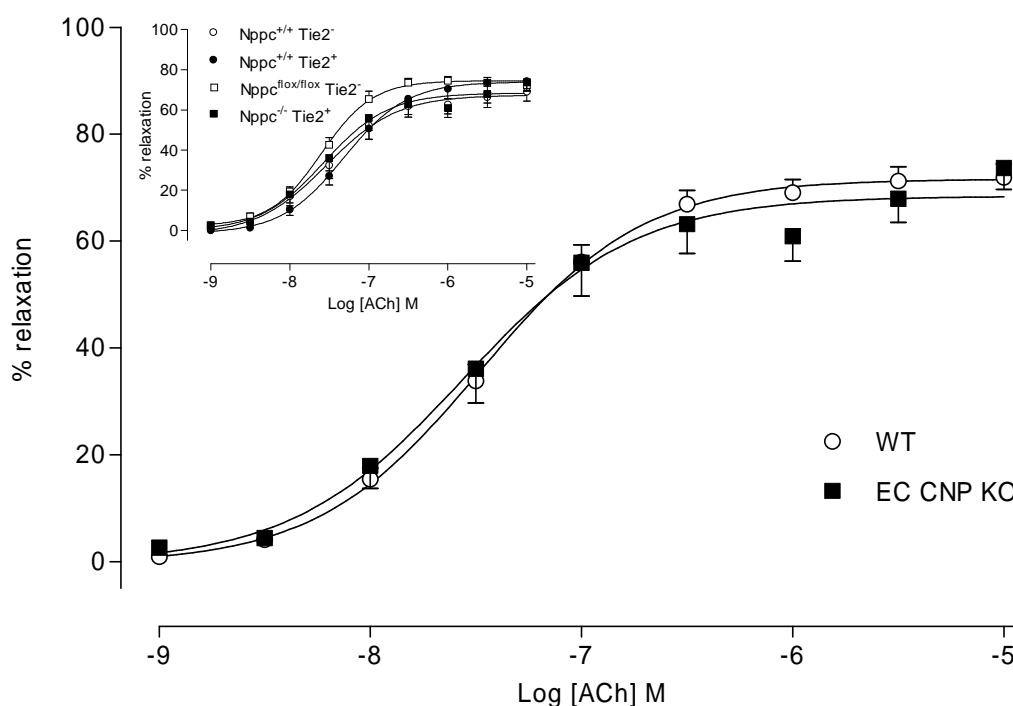

Figure 43 - Concentration-response curves to ACh in aortic rings from male WT and ecCNP KO mice

Inset graph shows concentration-response curves to ACh in male aortic rings from individual genotypes. Relaxation is expressed as mean \pm SEM percentage reversal of PE-induced tone; n=6-8.

	ACh pEC ₅₀ -log [M]	ACh E _{max} % relaxation
Nppc ^{+/+} Tie2 ⁻	7.53 \pm 0.14	69.02 \pm 4.73
Nppc ^{+/+} Tie2 ⁺	7.30 \pm 0.08	74.20 \pm 4.90
Nppc ^{flox/flox} Tie2 ⁻	7.60 \pm 0.05	74.47 \pm 2.27
WT	7.48 \pm 0.05	71.87 \pm 2.57
ecCNP KO	7.56 \pm 0.12	73.07 \pm 4.09

Table 7 - pEC₅₀ and E_{max} values of ACh in aortic rings from male WT and ecCNP KO mice

pEC₅₀ is expressed as mean \pm SEM -log [M]. E_{max} is expressed as mean \pm SEM percentage reversal of PE-induced tone; n=6-8.

Effect of ACh in aortic rings from female

WT and ecCNP KO mice

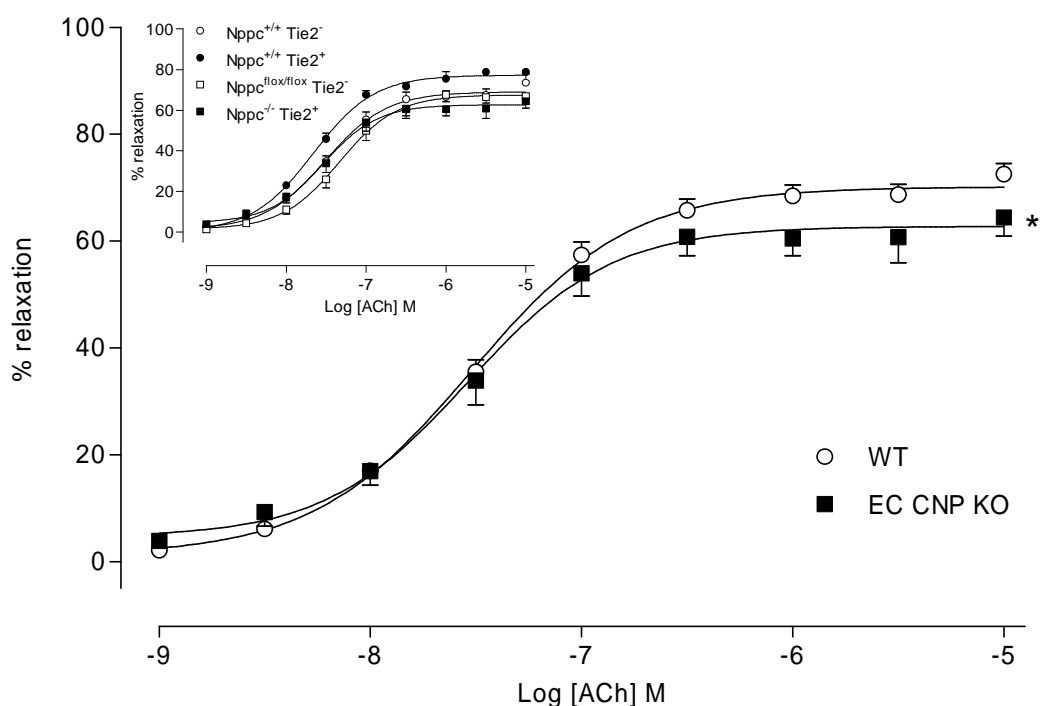

Figure 44 - Concentration-response curves to ACh in aortic rings from female WT and ecCNP KO mice

Inset graph shows concentration-response curves to ACh in female aortic rings from individual genotypes. Relaxation is expressed as mean \pm SEM percentage reversal of PE-induced tone. * $P < 0.05$ vs WT; $n = 6-8$.

	ACh pEC ₅₀ -log [M]	ACh E _{max} % relaxation
Nppc ^{+/+} Tie2 ⁻	7.51 \pm 0.07	73.53 \pm 4.29
Nppc ^{+/+} Tie2 ⁺	7.66 \pm 0.04	78.83 \pm 1.61
Nppc ^{flox/flox} Tie2 ⁻	7.33 \pm 0.07	67.59 \pm 3.52
WT	7.52 \pm 0.04	72.56 \pm 1.96
ecCNP KO	7.54 \pm 0.08	64.44 \pm 3.53*

Table 8 - pEC₅₀ and E_{max} values of ACh in aortic rings from female WT and ecCNP KO mice

pEC₅₀ is expressed as mean \pm SEM -log [M]. E_{max} is expressed as mean \pm SEM percentage reversal of PE-induced tone. * $P < 0.05$ vs WT; $n = 6-8$.

**Effect of CNP in aortic rings from male
WT and ecCNP KO mice**

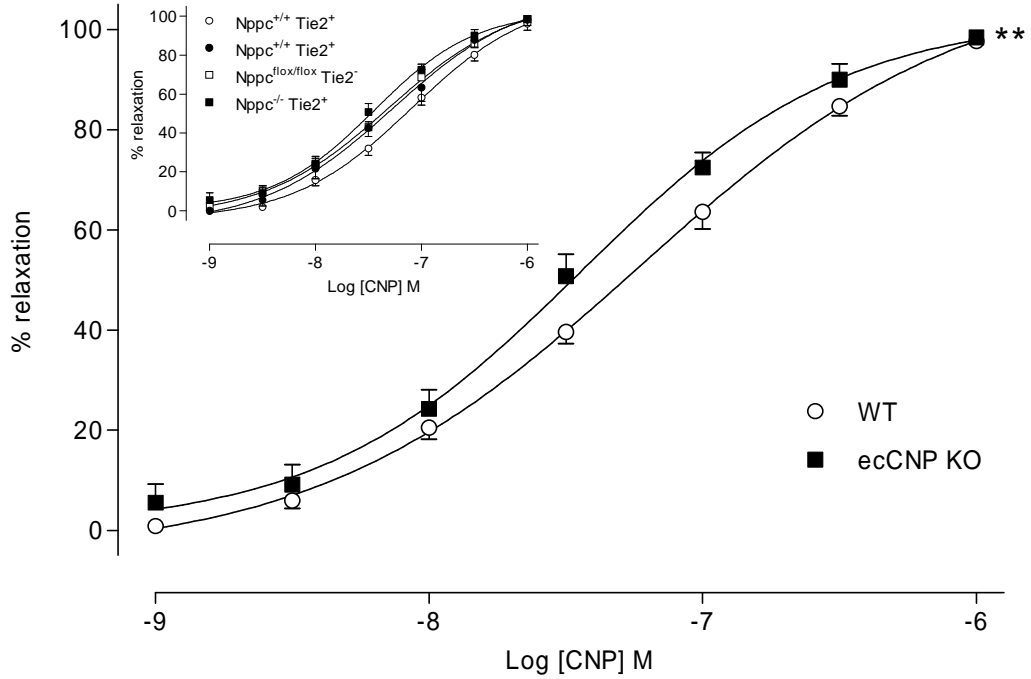

Figure 45 - Concentration-response curves to CNP in aortic rings from male WT and ecCNP KO mice

Inset graph shows concentration-response curves to CNP in male aortic rings from individual genotypes. Relaxation is expressed as mean \pm SEM percentage reversal of PE-induced tone. ** $P < 0.01$ vs WT; n=5-6.

	CNP pEC ₅₀ -log [M]	CNP E _{max} % relaxation
Nppc ^{+/+} Tie2 ⁻	7.09 \pm 0.09	96.25 \pm 3.43
Nppc ^{+/+} Tie2 ⁺	7.28 \pm 0.15	98.12 \pm 2.78
Nppc ^{flox/flox} Tie2 ⁻	7.31 \pm 0.08	98.52 \pm 1.63
WT	7.23 \pm 0.08	97.70 \pm 1.44
ecCNP KO	7.45 \pm 0.07	98.47 \pm 0.97

Table 9 - pEC₅₀ and E_{max} values of CNP in aortic rings from male WT and ecCNP KO mice

pEC₅₀ is expressed as mean \pm SEM -log [M]. E_{max} is expressed as mean \pm SEM percentage reversal of PE-induced tone; n=5-6.

Effect of CNP in aortic rings from female WT and ecCNP KO mice

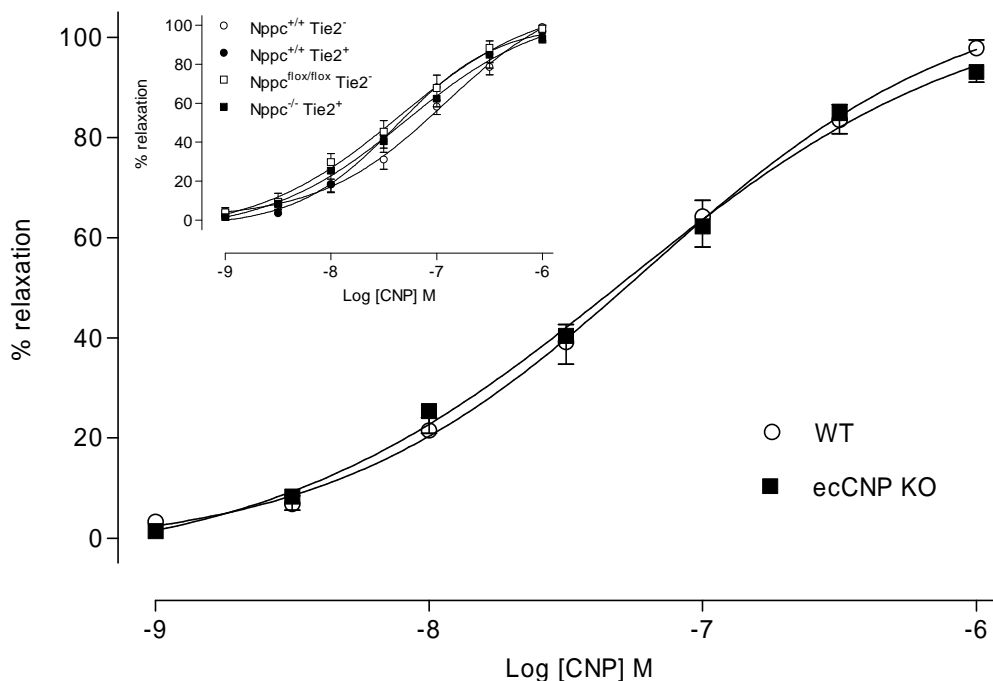

Figure 46 - Concentration-response curves to CNP in aortic rings from female WT and ecCNP KO mice

Inset graph shows concentration-response curves to CNP in female aortic rings from individual genotypes. Relaxation is expressed as mean \pm SEM percentage reversal of PE-induced tone; n=5-6.

	CNP pEC ₅₀ -log [M]	CNP E _{max} % relaxation
Nppc ^{+/+} Tie2 ⁻	6.92 \pm 0.17	99.02 \pm 1.96
Nppc ^{+/+} Tie2 ⁺	7.38 \pm 0.11	96.32 \pm 4.23
Nppc ^{flox/flox} Tie2 ⁻	7.36 \pm 0.17	98.19 \pm 1.97
WT	7.20 \pm 0.09	97.89 \pm 2.05
ecCNP KO	7.29 \pm 0.14	93.07 \pm 2.05

Table 10 - pEC₅₀ and E_{max} values of CNP in aortic rings from female WT and ecCNP KO mice

pEC₅₀ is expressed as mean \pm SEM -log [M]. E_{max} is expressed as mean \pm SEM percentage reversal of PE-induced tone; n=5-6.

Effect of Sper-NO in aortic rings from male WT and ecCNP KO mice

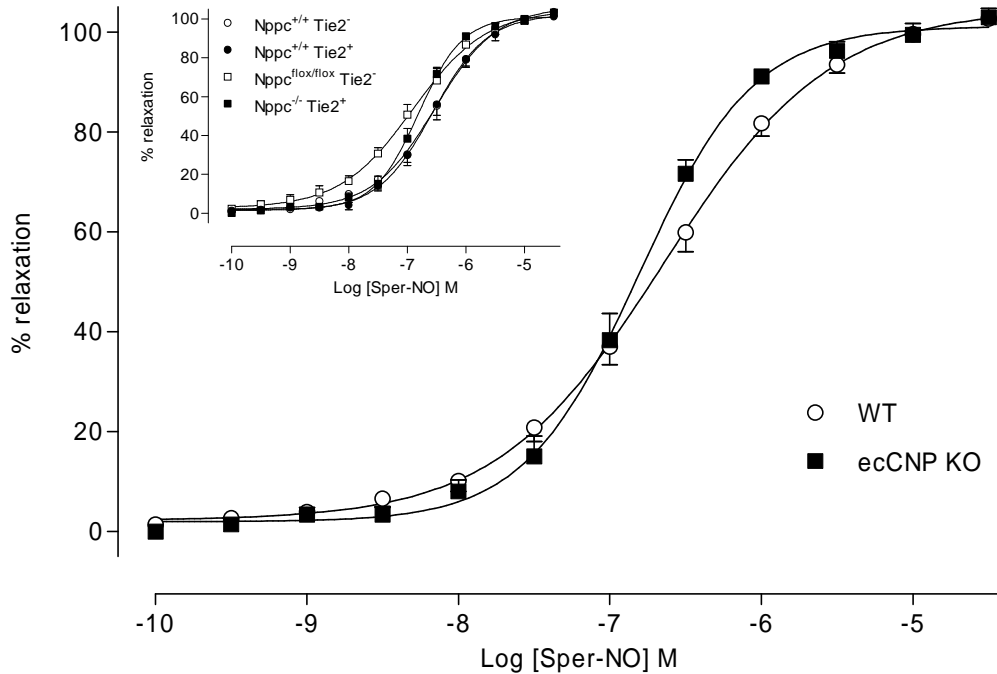

Figure 47 - Concentration-response curves to Sper-NO in aortic rings from male WT and ecCNP KO mice

Inset graph shows concentration-response curves to Sper-NO in male aortic rings from individual genotypes. Relaxation is expressed as mean \pm SEM percentage reversal of PE-induced tone; n=5-6.

	Sper-NO pEC ₅₀ -log [M]	Sper-NO E _{max} % relaxation
Nppc ^{+/+} Tie2 ⁻	6.53 \pm 0.07	103.51 \pm 1.67
Nppc ^{+/+} Tie2 ⁺	6.57 \pm 0.04	101.20 \pm 0.76
Nppc ^{flox/flox} Tie2 ⁻	6.91 \pm 0.08	103.38 \pm 1.74
WT	6.65 \pm 0.04	102.70 \pm 0.83
ecCNP KO	6.80 \pm 0.03*	102.89 \pm 1.83

Table 11 - pEC₅₀ and E_{max} values of Sper-NO in aortic rings from male WT and ecCNP KO mice
pEC₅₀ is expressed as mean \pm SEM -log [M]. E_{max} is expressed as mean \pm SEM percentage reversal of PE-induced tone. *P<0.05 vs WT; n=5-6.

Effect of Sper-NO in aortic rings from female

WT and ecCNP KO mice

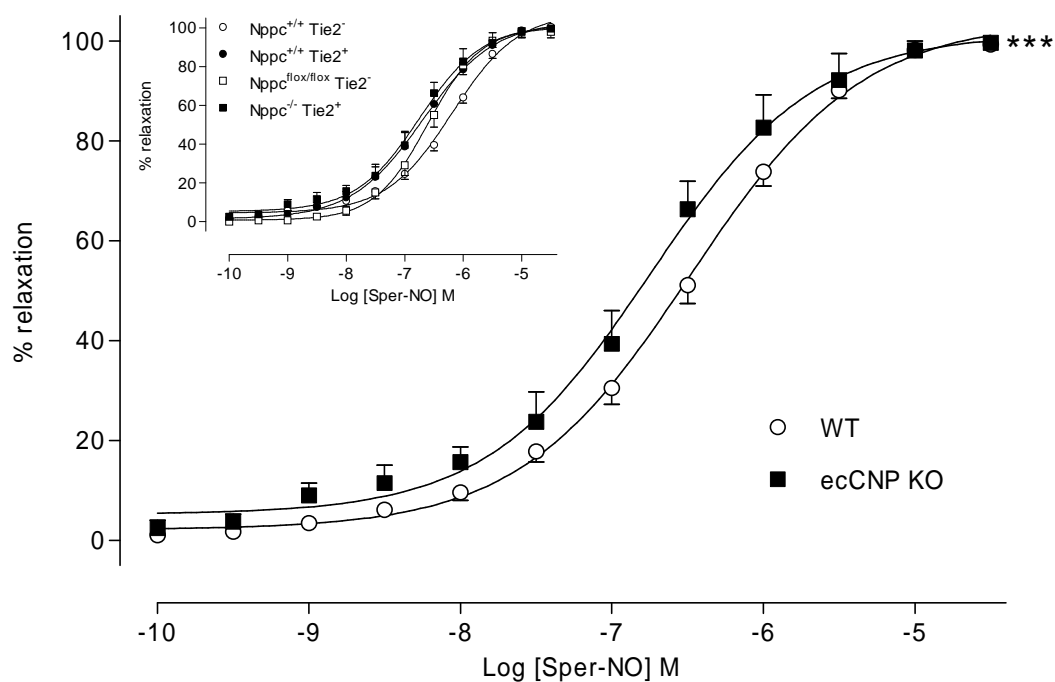

Figure 48 - Concentration-response curves to Sper-NO in aortic rings from female WT and ecCNP KO mice

Inset graph shows concentration-response curves to Sper-NO in female aortic rings of individual genotypes. Relaxation is expressed as mean \pm SEM percentage reversal of PE-induced tone. *** $P < 0.001$ vs WT; $n = 5-6$.

	Sper-NO pEC ₅₀ -log [M]	Sper-NO E _{max} % relaxation
Nppc ^{+/+} Tie2 ⁻	6.19 \pm 0.05	100.57 \pm 2.03
Nppc ^{+/+} Tie2 ⁺	6.70 \pm 0.08	99.35 \pm 1.72
Nppc ^{flox/flox} Tie2 ⁻	6.60 \pm 0.05	97.89 \pm 2.98
WT	6.48 \pm 0.04	99.34 \pm 1.27
ecCNP KO	6.75 \pm 0.08**	99.63 \pm 1.31

Table 12 - pEC₅₀ and E_{max} values of Sper-NO in aortic rings from female WT and ecCNP KO mice

pEC₅₀ is expressed as mean \pm SEM -log [M]. E_{max} is expressed as mean \pm SEM percentage reversal of PE-induced tone. ** $P < 0.01$ vs WT; $n = 5-6$.

4.4 Effect of endothelial CNP gene knockout on functional reactivity of mesenteric artery

Mesenteric artery reactivity was assessed in 16 - 20 week old ecCNP KO mice, as CNP has been shown to be an EDHF in rat mesenteric arteries (Villar *et al.*, 2007). Concentration-response curves to ACh were constructed in male and female mesenteric arteries that were pre-treated with the NOS inhibitor, L-NAME (300 μ M), and the COX inhibitor, indomethacin (5 μ M), and contracted with an EC₈₀ concentration of U46619. These studies were carried out by Dr Amie Moyes as previously described (Scotland *et al.*, 2005c).

ACh responses were unaltered in ecCNP KO male mesenteric arteries, compared to WT (Figure 49). ecCNP KO female mesenteric arteries exhibited a significant rightward shift of the ACh concentration-response curve versus WT (Figure 50). This was accompanied by a significant reduction in potency (pEC₅₀: 6.89 ± 0.14 and 5.94 ± 0.38 , WT and ecCNP KO, respectively) and a trend towards a reduced E_{max} (86.54 ± 2.15 and 77.01 ± 10.59 , WT and ecCNP KO, respectively).

Effect of ACh in mesenteric arteries from male WT and ecCNP KO mice pre-treated with L-NAME and indomethacin

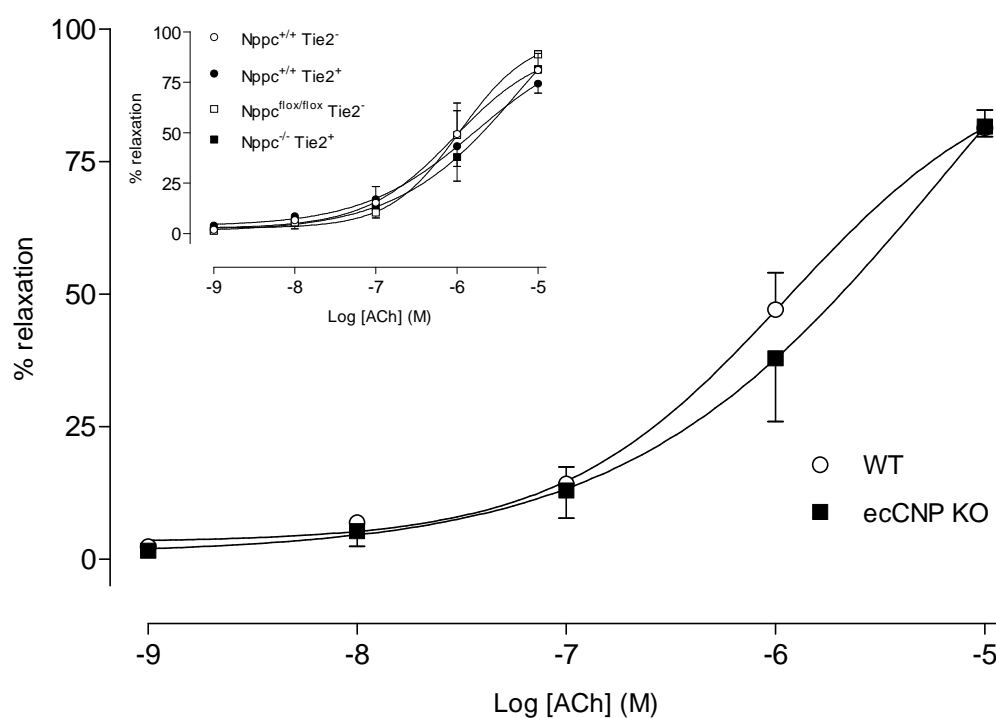

Figure 49 - Concentration-response curves to ACh in mesenteric arteries from male WT and ecCNP KO mice in the presence of L-NAME and indomethacin

Inset graph shows concentration-response curves to ACh in male mesenteric arteries from individual genotypes. Relaxation is expressed as mean \pm SEM percentage reversal of U46619-induced tone; n=6.

	ACh pEC ₅₀ -log [M]	ACh E _{max} % relaxation
Nppc ^{+/+} Tie2 ⁻	6.03 \pm 0.45	81.01 \pm 8.34
Nppc ^{+/+} Tie2 ⁺	5.77 \pm 0.73	74.29 \pm 4.65
Nppc ^{flox/flox} Tie2 ⁻	5.97 \pm 0.20	88.73 \pm 2.10
WT	5.95 \pm 0.22	81.34 \pm 3.38
ecCNP KO	5.17 \pm 1.97	81.59 \pm 1.94

Table 13 - pEC₅₀ and E_{max} values of ACh in mesenteric arteries from male WT and ecCNP KO mice in the presence of L-NAME and indomethacin

pEC₅₀ is expressed as mean \pm SEM -log [M]. E_{max} is expressed as mean \pm SEM percentage reversal of U46619-induced tone; n=6.

**Effect of ACh in mesenteric arteries from WT and ecCNP KO mice
pre-treated with L-NAME and indomethacin**

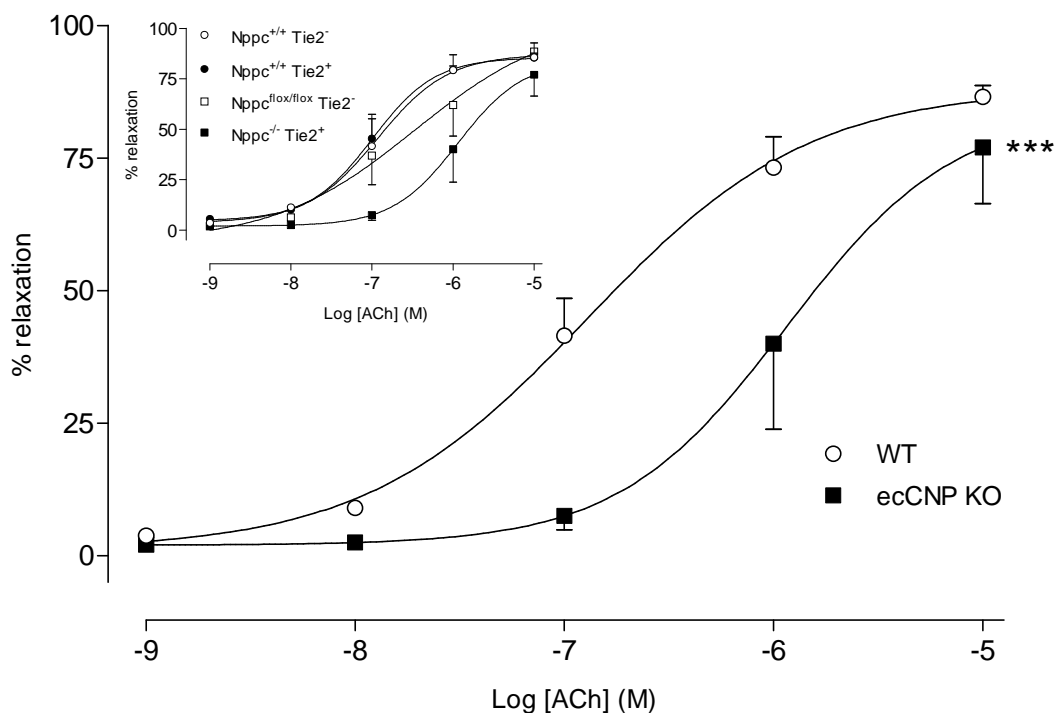

Figure 50 - Concentration-response curves to ACh in mesenteric arteries from female WT and ecCNP KO mice in the presence of L-NAME and indomethacin

Inset graph shows concentration-response curves to ACh in female mesenteric arteries from individual genotypes. Relaxation is expressed as mean \pm SEM percentage reversal of U46619-induced tone. ***P<0.01 vs WT; n=4-7.

	ACh pEC ₅₀ -log [M]	ACh E _{max} % relaxation
Nppc ^{+/+} Tie2 ⁻	6.93 \pm 0.22	85.62 \pm 7.28
Nppc ^{+/+} Tie2 ⁺	7.00 \pm 0.11	85.44 \pm 2.39
Nppc ^{flox/flox} Tie2 ⁻	6.47 \pm 0.69	88.45 \pm 3.39
WT	6.89 \pm 0.14	86.54 \pm 2.15
ecCNP KO	5.94 \pm 0.38*	77.01 \pm 10.59

Table 14 - pEC₅₀ and E_{max} values of ACh in mesenteric arteries from female WT and ecCNP KO mice in the presence of L-NAME and indomethacin

pEC₅₀ is expressed as mean \pm SEM -log [M]. E_{max} is expressed as mean \pm SEM percentage reversal of U46619-induced tone. *P<0.05 vs WT; n=4-7.

4.5 Effect of endothelial CNP gene knockout on blood pressure, heart rate and activity

To determine the role of endothelial derived CNP on blood pressure, WT and ecCNP KO mice were implanted with a DSI PhysioTel® PA-C10 telemetry probe, allowing continuous measurement of MABP, heart rate and activity in conscious animals. Mice used in these studies were aged between 16 - 20 weeks at the time of implantation. Animals were housed under a 12 h light dark cycle (light from 8 am to 8 pm) and haemodynamic recordings were taken for 64 h over the weekend to minimise noise disturbances. Data shown in this section is the 24 h period between Saturday 2 pm to Sunday 2 pm.

4.5.1 Blood pressure

Irrespective of genotype, male (Figure 51) and female (Figure 52) mice had raised MABP in the dark period, compared to the light period. In male ecCNP KO mice, MABP was not significantly altered over the 24 h period, compared to WT (Figure 53). Female ecCNP KO mice had a significantly raised MABP over the 24 h period versus WT (105.5 ± 0.68 mmHg and 114.9 ± 1.04 mmHg; WT and ecCNP KO, respectively; Figure 54).

4.5.2 Heart rate

In comparison to WT, male ecCNP KO mice exhibited a significantly raised heart rate, over the 24 h period (523.0 ± 4.98 beats/min (bpm) and 548.1 ± 4.10 bpm; WT and ecCNP KO, respectively; Figure 55). The heart rate of female ecCNP KO mice was significantly lower versus WT, over the 24 h period (600.0 ± 3.49 bpm and 569.1 ± 4.80 bpm; WT and ecCNP KO, respectively; Figure 56).

4.5.3 Activity

Over the 24 h period, male ecCNP KO mice exhibited increased activity, compared to WT (Figure 57), whilst activity of female ecCNP KO mice was decreased in comparison to WT (Figure 58).

Circadian rhythm of MABP in male and female WT and ecCNP KO mice

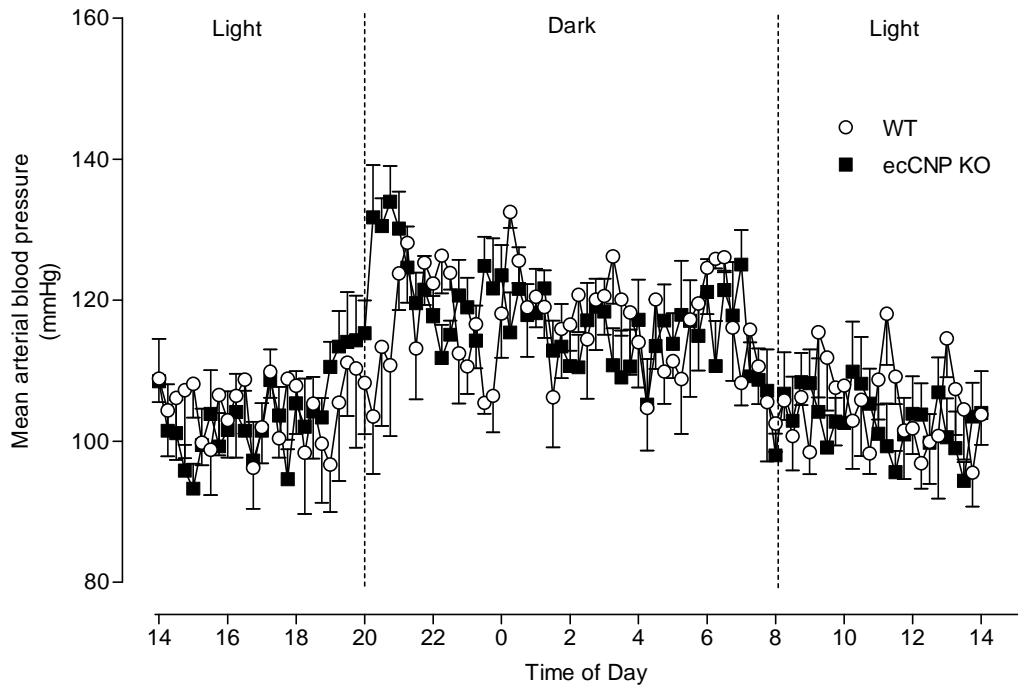

Figure 51 - Circadian rhythm of MABP in male WT and ecCNP KO mice

Data are represented as mean \pm SEM, n=6-8.

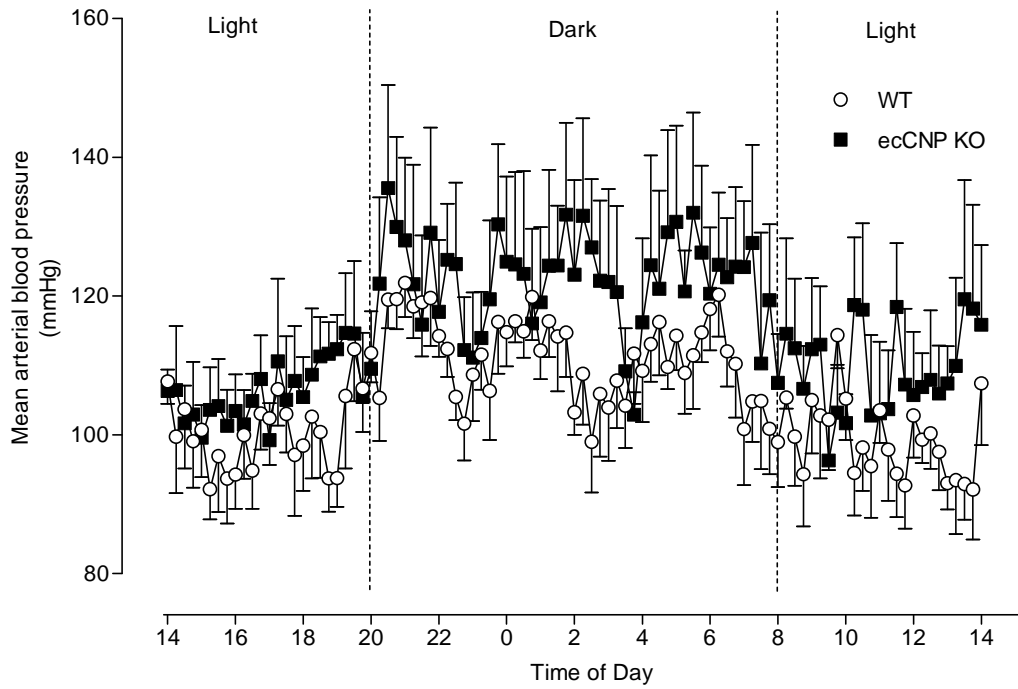

Figure 52 - Circadian rhythm of MABP in female WT and ecCNP KO mice

Data are represented as mean \pm SEM, n=5-6.

MABP of male and female WT and ecCNP KO mice

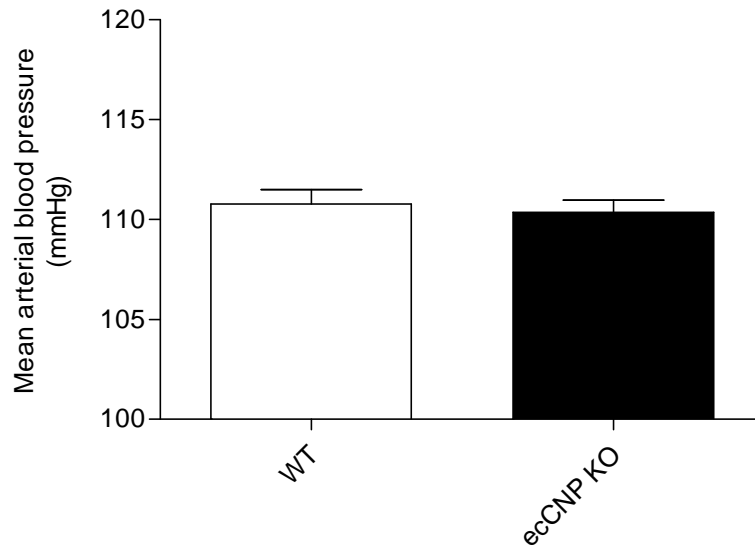

Figure 53 - MABP of male WT and ecCNP KO mice

Data are represented as mean \pm SEM, n=6-8.

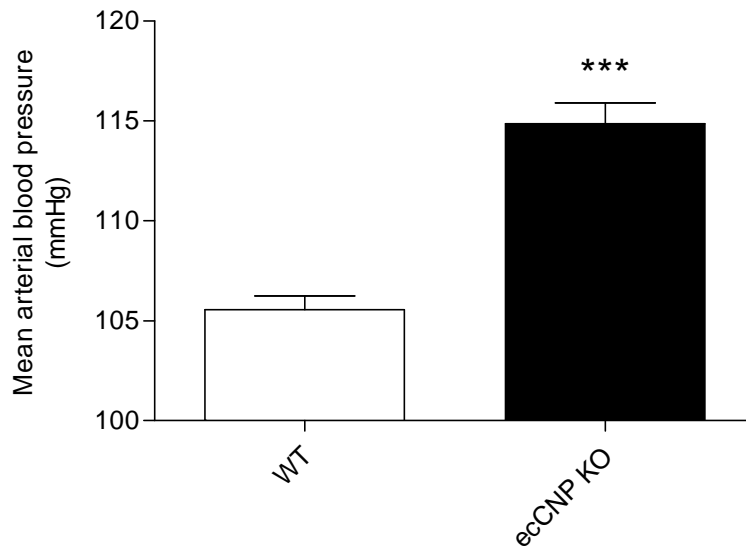

Figure 54 - MABP of female WT and ecCNP KO mice

Data are represented as mean \pm SEM. ***P<0.001 vs WT; n=5-6.

Heart rate of male and female WT and ecCNP KO mice

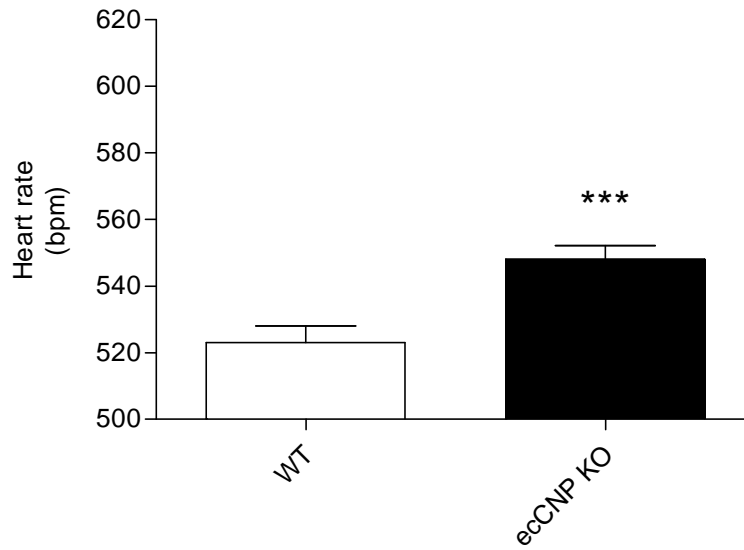

Figure 55 - Heart rate of male WT and ecCNP KO mice

Data are represented as mean \pm SEM. ***P<0.001 vs WT; n=6-8.

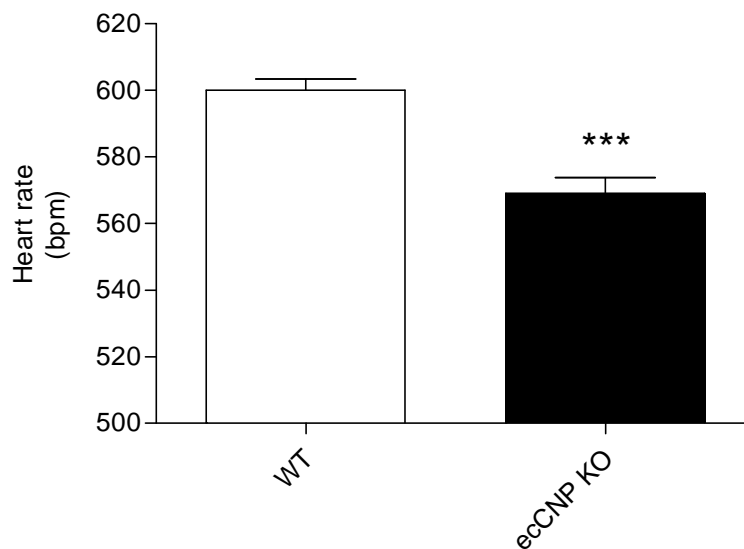

Figure 56 - Heart rate of female WT and ecCNP KO mice

Data are represented as mean \pm SEM. ***P<0.001 vs WT; n=5-6.

Activity of male and female WT and ecCNP KO mice

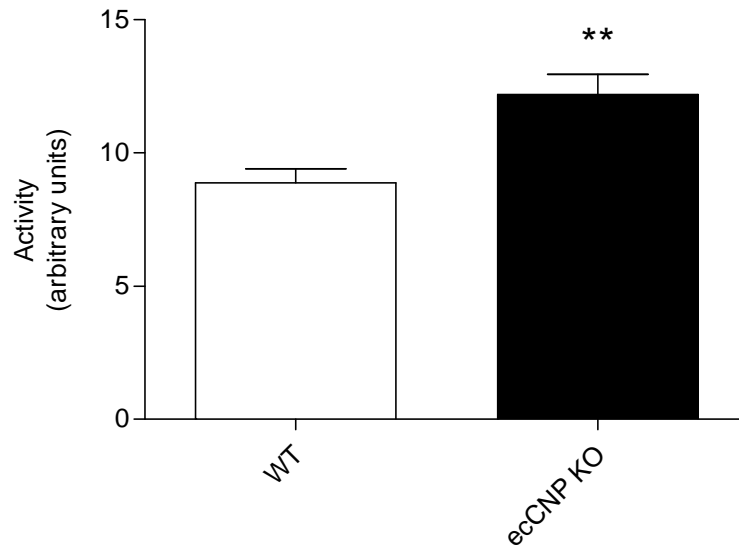

Figure 57 - Activity of male WT and ecCNP KO mice

Data are represented as mean \pm SEM. **P<0.01 vs WT; n=6-8.

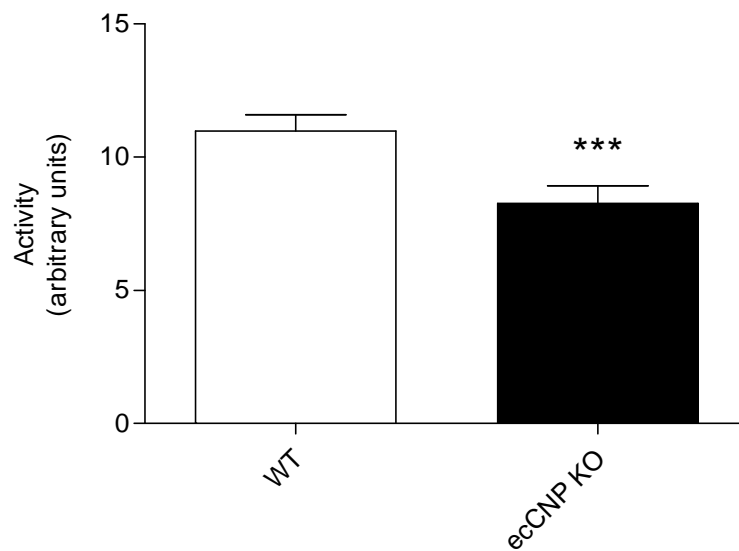

Figure 58 - Activity of female WT and ecCNP KO mice

Data are represented as mean \pm SEM. ***P<0.001 vs WT; n=5-6.

4.6 Summary of key results

Thoracic aorta reactivity to contractile agents was unchanged in male and female ecCNP KO mice, compared to WT. In males, the relaxant response to ACh was unchanged; however, in females responsiveness to ACh was reduced. Female thoracic aorta from ecCNP KO mice was more sensitive to the NO donor, Sper-NO, compared to WT; this was not apparent in male ecCNP KO animals. ecCNP KO female mesenteric arteries exhibited reduced potency, versus WT, to the endothelium-dependent vasodilator ACh, whilst it remained unchanged in males.

Female ecCNP KO mice exhibited raised MABP, demonstrating a role for endothelium-derived CNP in blood pressure regulation in these animals. This rise in MABP was accompanied by a reduction in heart rate and activity. Male ecCNP KO mice did not exhibit altered MABP, however these animals did have raised heart rates and activity. These data clearly demonstrate a role for endothelium-derived CNP in physiological blood pressure regulation, at least in females.

Chapter 5

Discussion

5 Discussion

5.1 Summary of key findings

I have shown that in HUVEC, CNP-mediated NPR-C activation leads to ERK 1/2 and Akt activation. In turn, CNP-mediated ERK 1/2 activation augments cyclin D1 expression, stimulating mitogenesis. In RAoSMC, CNP also elicits a NPR-C-mediated ERK 1/2 activation; however, in this cell type ERK 1/2 triggers expression of p21^{waf1/cip1} and p27^{kip1}, inhibiting growth. These data demonstrate that CNP-induced ERK 1/2 activation in endothelial and smooth muscle cells differentially regulates cell cycle protein expression and hence proliferation.

With the generation of an ecCNP KO mouse, I have demonstrated isolated mesenteric artery and thoracic aorta from female ecCNP KO mice exhibit an attenuated response to the endothelium-dependent dilator ACh, compared to vessels from WT litter mates. In contrast, ACh-induced relaxations in these vessels from male ecCNP KO mice were similar to WT animals. Female mice lacking endothelial CNP are hypertensive, whilst males are normotensive. These observations indicate that in females endothelium-derived CNP is involved in the regulation of artery tone and systemic blood pressure.

5.2 CNP as a regulator of endothelial cell proliferation

Previous work has shown CNP to promote growth of endothelial cells from various species and vessels, *in vitro*; human coronary artery endothelial cells (HCAEC; Ohno *et al.*, 2002), BAEC (Doi *et al.*, 2001), HUVEC (Yamahara *et al.*, 2003) and porcine aortic endothelial cells (Pelisek *et al.*, 2006). In the large part, CNP-induced endothelial cell proliferation has been suggested to occur via NPR-B activation, however, there are studies that suggest NPR-C may also be involved. For instance, CNP promotes proliferation and migration of HCAEC, whereas the selective NPR-C ligand, cANF⁴⁻²³, has no effect (Ohno *et al.*, 2002). Furthermore, natriuretic peptides augment HUVEC capillary network formation, an effect inhibited by the cGMP dependent protein kinase inhibitor Rp-8-pCPT-cGMP, intimating that this effect is

mediated by guanylyl cyclase linked NPR-B (Yamahara *et al.*, 2003). Moreover, cANF⁴⁻²³ has been shown to exert a very weak suppression of BAEC DNA synthesis, suggesting that NPR-C activation on endothelial cells, if anything, may result in attenuated cell growth (Itoh *et al.*, 1992). In contrast, I have provided clear evidence that cANF⁴⁻²³ promotes HUVEC proliferation to a similar magnitude as CNP, and that the effect of both peptides is blocked by M372049, a selective NPR-C antagonist. Additionally, I have taken a genetic approach to assess the role of NPR-C on cell growth; proliferation of endothelial cells derived from NPR-C KO mice was not altered by CNP, whereas growth of endothelial cells from WT mice were significantly enhanced. Such observations confirm an important role for NPR-C in the pro-mitogenic effect of CNP. A possible explanation for the discrepancy between my work and previous studies may be due to the proliferative effect of CNP being species or vessel specific. M372049 does not completely inhibit the proliferative action of CNP, suggesting a residual NPR-B dependent effect remains. However, the observations that cANF⁴⁻²³ is equipotent to CNP and that the pro-mitogenic effect of CNP is lost in NPR-C KO endothelial cells confirms a predominant role for NPR-C (over NPR-B) in this process. The incomplete inhibition by M372049 may simply result from a competitive antagonism.

In addition to delineating the receptor subtype involved in the proliferative effect of CNP, I have also identified the second messenger/intracellular pathways that underlie this response. The ERK 1/2 pathway has been shown to be activated by various growth factors that stimulate endothelial cell proliferation including VEGF, fibroblast growth factor-2, epidermal growth factor and hepatocyte growth factor (Pedram *et al.*, 1998; Wu *et al.*, 2000; Rikitake *et al.*, 2000; Nakagami *et al.*, 2001). In addition, various herbal extracts including *Pueraria thunbergiana* extract, Korean red ginseng water extract, icariin and sesamin, and the chemokine fractalkine promote endothelial cell proliferation in an ERK 1/2-dependent manner (Lee *et al.*, 2006; Kim *et al.*, 2007; Chung *et al.*, 2008; Chung *et al.*, 2010a; Chung *et al.*, 2010b). In this study, the ERK 1/2 inhibitor, PD98059, significantly inhibited the mitogenic response to CNP in HUVEC demonstrating a role for this arm of the MAPK signalling cascade in this process. Furthermore, CNP-mediated ERK 1/2 phosphorylation was blocked by M372049 and the G_{i/o} inhibitor, *Pertussis toxin*, demonstrating a clear link between activation of G_i-coupled NPR-C and stimulation of the ERK 1/2 pathway. This

observation is in accord with previous findings that have demonstrated numerous growth factors to stimulate G_i-coupled receptors e.g. sphingosine-1-phosphate and insulin like growth factor (New and Wong, 2007). Interestingly, many of these G_i coupled growth factor receptors possess a single transmembrane domain, akin to NPR-C, rather than the classical heptahelical structure. This homology supports a key role for NPR-C regulating mitogenesis.

In addition to implicating ERK 1/2 signalling in the mitogenic effect of CNP, I have also demonstrated a role for the PI3K/Akt pathway. In HUVEC, the structurally unrelated PI3K inhibitors, LY294002 and wortmannin, inhibited the mitogenic response to CNP. This observation suggests CNP acts in an analogous fashion to other growth factors including VEGF, *Pueraria thunbergiana* extract, Korean red ginseng water extract, icariin, sesamin and fractalkine that promote endothelial cell proliferation in an Akt-dependent manner (Yu and Sato, 1999; Glicki *et al.*, 2002; Kim *et al.*, 2007; Chung *et al.*, 2008; Chung *et al.*, 2010a; Chung *et al.*, 2010b). In the case of VEGF, it has been shown that phosphorylation of eNOS is triggered by Akt activation and endothelial cell growth is increased in a NO-dependent manner (Dimmeler *et al.*, 1999). In an attempt to explore if a similar mechanism underlies the mitogenic effects of CNP, I examined if eNOS phosphorylation was stimulated by CNP; however, this was not the case. Nonetheless, I was able to show that CNP-mediated Akt phosphorylation is blocked by M372049 and *Pertussis toxin*, hence implicating NPR-C in this process. These data suggest, in addition to NPR-C/ERK 1/2 signalling, CNP can promote endothelial cell proliferation via an NPR-C/PI3K/Akt pathway. In addition to eNOS, Akt has multiple downstream targets which can alter cell proliferation including glycogen synthase kinase-3 and forkhead box O1 which alter cyclin D1 and p21^{waf1/cip1} levels, respectively (Brader and Eccles, 2004). Whether CNP alters expression of these downstream targets is unknown.

Several endogenous mediators, including VEGF, fibroblast growth factor-2, angiopoietin-1 and 17 β -estradiol, increase cyclin D1 expression in endothelial cells, with a concomitant augmentation of proliferation (Pedram *et al.*, 1998; Kanda *et al.*, 2005; Fu *et al.*, 2007). VEGF and 17 β -estradiol have been shown to increase cyclin D1 expression in a PD98059-inhibitable manner, implicating ERK 1/2 as a positive regulator of cyclin D1 expression (Pedram *et al.*, 1998; Fu *et al.*, 2007). In HUVEC, I

have revealed that CNP also augments expression of cyclin D1 in an ERK 1/2-dependent manner. Furthermore, I have shown CNP attenuates expression of the cell cycle inhibitor p21^{waf1/cip1}, an effect akin to VEGF (Favot *et al.*, 2004). In concert, these observations provide a novel insight into the mechanism by which CNP promotes endothelial cell proliferation (see Figure 59).

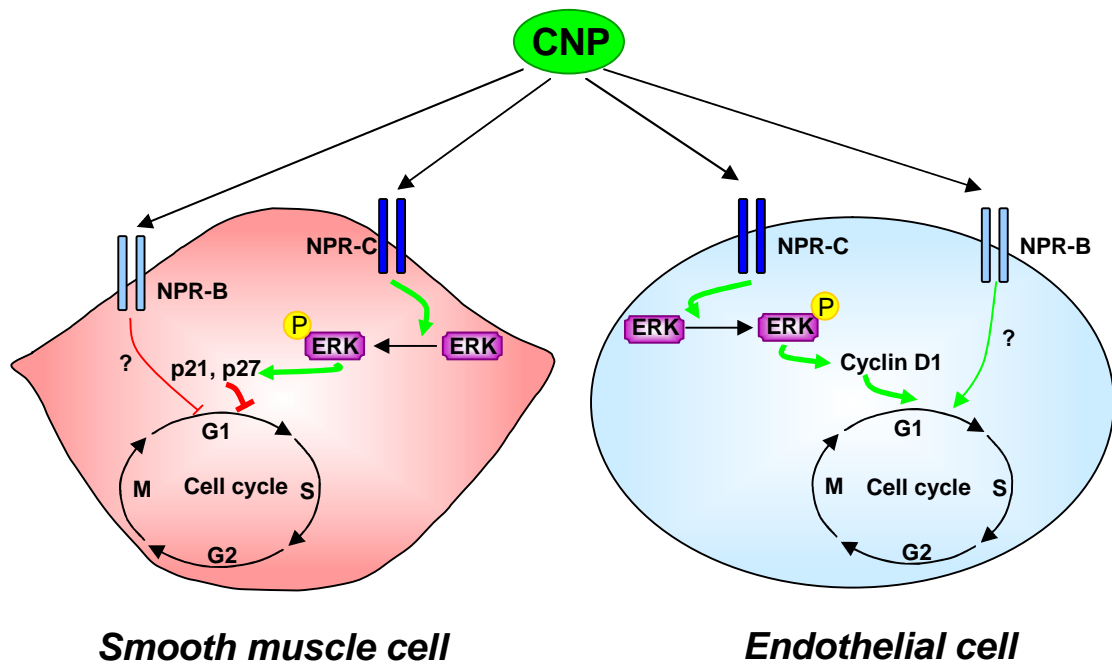

Figure 59 - Signalling pathway by which CNP mediates vascular cell proliferation

CNP - C-type natriuretic peptide, ERK - Extracellular signal-regulated kinase, G1 - First gap, G2 - Second Gap, M - Mitosis, NPR - Natriuretic peptide receptor, S - Synthesis

5.3 CNP as a regulator of VSMC proliferation

It is well established that CNP inhibits proliferation of smooth muscle cells, however conflicting evidence exists regarding the receptor involved. Furuya *et al* demonstrated raised levels of cGMP underlie CNP-induced inhibition of rat VSMC proliferation and CNP-treated injured rat carotid arteries, intimating that the receptor responsible is the guanylyl cyclase coupled NPR-B (Furuya *et al.*, 1991;Furuya *et al.*, 1993). Moreover, RAOsmc infected with an adenovirus encoding rat CNP exhibit significantly reduced growth with a concomitant increase in cGMP, also suggesting the effect is NPR-B

mediated (Doi *et al.*, 2001). Further still, growth inhibition correlates with cGMP levels in RAoSMC and in these cells the NPR-C selective agonists, cANF⁴⁻²³ and des[Cys¹⁰⁵,Cys¹²¹]rANP, are unable to inhibit proliferation (Hutchinson *et al.*, 1997). Contrary to the above observations, it has been suggested that CNP inhibits RAoSMC proliferation via NPR-C in a cGMP-independent manner (Cahill and Hassid, 1994).

Work from our lab has also shown that CNP-mediated inhibition of RAoSMC proliferation is mediated, at least in part, by NPR-C; this inhibitory effect is triggered by NPR-C-dependent ERK 1/2 phosphorylation (Panayiotou, 2007). Since I had shown that CNP/NPR-C-induced ERK 1/2 phosphorylation results in cyclin D1 expression and endothelial cell growth, I investigated which cell cycle proteins were responsible for the dichotomous effect of CNP (via NPR-C and ERK 1/2 activation) to inhibit VSMC growth (as opposed to augmenting HUVEC proliferation). Herein, I have demonstrated CNP elicits a time-dependent increase in p21^{waf1/cip1} and p27^{kip1} expression in an ERK 1/2-dependent manner in RAoSMC. This observation is consistent with previous findings which demonstrate an up-regulation of p21^{waf1/cip1} and p27^{kip1} expression in smooth muscle cells in response to the anti-mitogenic agents NO and sodium salicylate (Sato *et al.*, 2000;Marra *et al.*, 2000). It is also in accord with three independent studies which reported NO to increase ERK 1/2 phosphorylation resulting in inhibition of VSMC proliferation (in a cGMP-independent manner) with a concomitant increase in p21^{waf1/cip1} expression (Ishida *et al.*, 1999;Kibbe *et al.*, 2000;Bauer *et al.*, 2001). Thus, it appears a similar pathway underlies the anti-mitogenic effect of CNP, and this is predominantly cGMP-independent since I have shown that p21^{waf1/cip1} and p27^{kip1} up-regulation is the result of NPR-C activation.

Classically, VSMC pro-mitogenic mediators such as Ang II are thought to enhance ERK 1/2 activation, attenuating expression of p21^{waf1/cip1} and p27^{kip1} (He *et al.*, 2009;Chen *et al.*, 2009;Zhou *et al.*, 2009). Contrary to this, I have demonstrated that in VSMC CNP elicits ERK 1/2 activation leading to an increase in p21^{waf1/cip1} and p27^{kip1} levels. This correlates with the observation that PDGF, although a pro-mitogenic factor for VSMC, increases p21^{waf1/cip1} expression in an ERK 1/2 dependent manner (Marra *et al.*, 2000;Lee and Moon, 2005), supporting the hypothesis that ERK 1/2 activation leads to p21^{waf1/cip1} induction. Thus, despite ERK 1/2 phosphorylation

often being associated with cell growth, the studies described above and those from our lab, demonstrate that ERK 1/2 activation can also increase expression of p21^{waf1/cip1} and p27^{kip1} resulting in growth inhibition.

Interestingly, in RAoSMC CNP also elicited an increase in cyclin D1 expression, which was unexpected since cyclin D1 is a promoter of the cell cycle. As described above, NO increases expression of p21^{waf1/cip1} and p27^{kip1} and, akin to CNP, also increases cyclin D1 expression (Ishida *et al.*, 1997). However, other inhibitors of VSMC proliferation such as rapamycin and lovastatin reduce cyclin D1 expression (Hashemolhosseini *et al.*, 1998; Oda *et al.*, 1999). The reason for the raised cyclin D1 expression I report here is unknown; however, it may be a regulatory feedback mechanism to counteract the significantly raised levels of p21^{waf1/cip1} and p27^{kip1}.

An additional mechanism by which CNP may alter cell cycle proteins is via the expression of a homeobox gene termed growth arrest-specific homeobox (Gax), a gene encoding a transcription factor. The Gax gene has been shown to be largely confined to the cardiovascular system such as the aorta, heart, lung and kidney (Gorski *et al.*, 1993). Gax expression is attenuated by PDGF, Ang II and serum in VSMC (Gorski *et al.*, 1993; Yamashita *et al.*, 1997) and also in rat carotid artery following endothelial denudation by balloon angioplasty (Weir *et al.*, 1995). Gax has been shown to be present in VSMC and endothelial cells in normal human arteries and overexpression of Gax in HUVEC and VSMC results in increased p21^{waf1/cip1} expression (Smith *et al.*, 1997; Gorski and Leal, 2003). Furthermore, overexpression of Gax in rabbit iliac arteries that have undergone balloon angioplasty and stent deployment, exhibit reduced neointimal hyperplasia (Maillard *et al.*, 2000). This data suggests that Gax is likely to have a regulatory function in the G₀/G₁ transition phase of the cell cycle in VSMC. CNP augments Gax expression in VSMC (Yamashita *et al.*, 1997), which would be anticipated to increase p21^{waf1/cip1} expression and bring about growth inhibition. However, the effect of CNP on Gax expression in HUVEC is yet to be determined.

In summary, I have identified that in HUVEC, CNP mediated NPR-C activation increases ERK 1/2 and (Akt phosphorylation), which in turn modulates cell cycle protein expression (i.e. cyclin D1) to promote proliferation. In contrast, in VSMC

CNP mediated NPR-C activation increases ERK 1/2 phosphorylation, promoting expression of the cell cycle inhibitors p21^{waf1/cip1} and p27^{kip1}, resulting in inhibition of VSMC growth.

5.4 The role of CNP in cardiovascular homeostasis

CNP is a potent vasodilator of conduit (Drewett *et al.*, 1995; Wennberg *et al.*, 1999; Madhani *et al.*, 2003) and resistance arteries (Chauhan *et al.*, 2003; Villar *et al.*, 2007; Kun *et al.*, 2008) and administration of CNP to human volunteers, monkeys, dogs and rats causes a transient reduction in blood pressure (Clavell *et al.*, 1993; Igaki *et al.*, 1996; Seymour *et al.*, 1996; Aizawa *et al.*, 2008). These observations indicate that CNP may be able to regulate blood pressure by altering the contractile state of the resistance vasculature.

Since the seminal observation that removal of the endothelium from isolated arteries prevents the dilator response to ACh (Furchgott and Zawadzki, 1980), there has been great interest in the role of the endothelium in vasomotor tone. NO and PGI₂ are endothelium-derived vasodilators with anti-mitogenic, anti-inflammatory and anti-thrombotic properties, which are major contributors to vascular homeostasis (Moncada and Higgs, 1993; Fetalvero *et al.*, 2007). Endothelium-dependent relaxations are sometimes partially or totally resistant to COX and NOS inhibition and accompanied by smooth muscle cell hyperpolarisation (Busse *et al.*, 2002; Feletou and Vanhoutte, 2009). These observations are attributed to a third endothelium-derived factor termed EDHF, which has been shown to have an increasing importance as vessel size decreases (Shimokawa *et al.*, 1996; Brandes *et al.*, 2000). The importance of EDHF in blood pressure maintenance has been illustrated using eNOS/COX-1 double KO mice, which are unable to synthesise endothelium-derived NO and PGI₂. Male eNOS/COX-1 mice are hypertensive whereas female eNOS/COX-1 mice are normotensive, in comparison to WT (Scotland *et al.*, 2005c). These data intimate that female mice use EDHF to regulate blood pressure whereas males are more reliant on NO.

The identify of EDHF is unknown, however, it is likely that it varies across species and vascular beds. Numerous candidates have been suggested to be EDHF, such as

potassium ions, cytochrome P450 products, hydrogen peroxide and CNP (Feletou and Vanhoutte, 2009; Luksha *et al.*, 2009). Work from our lab has identified CNP to be an EDHF in the rat mesenteric and coronary circulation and this function has been demonstrated to be mediated via NPR-C signalling (Chauhan *et al.*, 2003; Hobbs *et al.*, 2004; Villar *et al.*, 2007). The observations that exogenous CNP can modify vascular tone and blood pressure, and appears to act as an EDHF, led us to develop a mouse with selective deletion of CNP in vascular endothelial cells (ecCNP KO) to test the physiological role of endothelium-derived CNP in cardiovascular homeostasis. This experimental approach was chosen as no suitable *in vivo* tools are available to selectively block CNP/NPR-C signalling and, moreover, global CNP KO mice have gross bone deformation and a high mortality rate (Komatsu *et al.*, 2002), preventing meaningful analysis of the cardiovascular system.

In male and female ecCNP KO thoracic aorta, responses to the contractile agents PE and U46619 were identical to WT. In males, endothelium-dependent relaxations to ACh were unchanged whilst in females the ACh response was significantly reduced, compared to WT, albeit marginally. This data indicates that CNP may have a minor role in endothelial function in conduit arteries of females. This is surprising as it is thought that the contribution of EDHF to vascular tone of large conduit arteries is negligible (Luksha *et al.*, 2009). Indeed, it has been shown that in aortic rings from eNOS KO mice the ACh response is completely abolished (Scotland *et al.*, 2005c), suggesting there is little or no EDHF component found in the aorta. A possible explanation for this discrepancy may be that CNP acts via NO to elicit aortic relaxation. In HUVEC, CNP increases nitrite and nitrate (stable metabolites of NO), suggesting CNP augments NO production (Rautureau *et al.*, 2010). However, CNP-induced relaxation of rat aortic rings is unaffected by pre-treatment with L-N^G-nitroarginine (L-NNA), a NOS inhibitor (Brunner and Wolkart, 2001), questioning whether NO is involved in mediating the vasodilator effect of CNP. Nonetheless, my observations suggest CNP is produced by the aortic endothelium and may have a minor role in maintaining aortic tone, at least in females.

Although EDHF has a minor role in large conduit arteries, I assessed if a lack of CNP affected the potency of NO in aortic rings from ecCNP KO mice. The EDHF pathway can compensate for a lack of NO, which is important in CVD where NO bioactivity is

compromised and I hypothesised that the opposite may be true – that loss of CNP may be compensated by an increase of NO sensitivity. This idea has arisen due to the findings that production of EDHF is dampened by NO in rabbit carotid, porcine and mongrel dog coronary arteries (Bauersachs *et al.*, 1996;Nishikawa *et al.*, 2000) and mesenteric arteries from eNOS KO mice display similar myogenic tone to WT due to an up-regulation of EDHF (Scotland *et al.*, 2001). Thoracic aorta from female ecCNP KO mice exhibited greater sensitivity to Sper-NO suggesting a compensatory mechanism by which a lack of CNP initiates an up-regulation of the NO pathway. Indeed, crosstalk between the NO-sGC and natriuretic peptide-pGC pathways has been shown to occur *in vitro* and *in vivo* (Madhani *et al.*, 2003;Madhani *et al.*, 2006;discussed in section 5.8) supporting the above hypothesis. These data imply that a reduction in CNP could potentially trigger an up-regulation of the NO pathway and/or its components, possibly at the guanylyl cyclase level.

The relaxation response to ACh in female ecCNP KO mesenteric artery was significantly reduced versus WT, suggesting CNP to be an EDHF in the mouse mesenteric artery. This compliments previous findings, identifying CNP as an EDHF in the rat mesenteric and coronary arteries (Chauhan *et al.*, 2003;Hobbs *et al.*, 2004;Villar *et al.*, 2007). Interestingly, in male ecCNP KO mesenteric artery the ACh response was unaltered, compared to WT, suggesting either males lack an EDHF component in the mesenteric artery or that an alternative EDHF exists within the male vasculature. The former hypothesis is the most likely, as in the resistance vasculature endothelium-dependent relaxations in males are predominantly mediated by NO (McCulloch and Randall, 1998;Pak *et al.*, 2002;Scotland *et al.*, 2005c). In summary, these *in vitro* data identify CNP as an EDHF in the female mouse mesenteric artery, suggesting there is a sex difference in the regulation of resistance vessel tone and may be responsible for lower MABP in females.

To translate these *in vitro* observations to an *in vivo* setting I used radiotelemetric monitoring to explore if endothelium-derived CNP has a physiological role in regulating MABP. I observed a significant increase in MABP in female ecCNP KO mice compared to WT littermates. In contrast male WT and ecCNP KO mice had equivalent MABP. These observations complement the isolated vessel data since arteries isolated from female ecCNP KO were dysfunctional and lacked an EDHF

response, in comparison to WT, whereas vascular reactivity was comparable between arteries isolated from male WT and ecCNP KO mice. This study reinforces previous work demonstrating that exogenous CNP is able to modulate vascular tone and blood pressure but goes one step further in identifying a pivotal role for endogenous CNP in maintaining cardiovascular homeostasis *in vivo*.

My work has also identified male ecCNP KO mice to have raised heart rates and, contrastingly, female ecCNP KO mice to have lower heart rates than WT controls. A possible explanation for this sex difference may be due to the changes observed in MABP. Female ecCNP KO mice are hypertensive and so a reduction in heart rate may be a compensatory mechanism to counteract the raised blood pressure. Under physiological conditions the baroreceptor reflex mechanism maintains blood pressure, such that an increase is counteracted by a reduction in heart rate. However, this is an acute response and a long term increase in blood pressure is thought to cause the baroreceptors to reset to the new pressure hence returning heart rate to baseline (Ortiz and Garvin, 2003). However, male and female eNOS KO mice are hypertensive and numerous studies have shown them to have persistently reduced heart rates (Shesely *et al.*, 1996; Godecke *et al.*, 1998; Kurihara *et al.*, 1998; Stauss *et al.*, 1999; Yang *et al.*, 1999), suggesting the baroreceptor reflex remains chronically functional; the same appears to be true for female ecCNP KO mice.

Male ecCNP KO mice are not hypertensive, ruling out the possibility that a compensatory mechanism is responsible for the increase in heart rate observed in these animals. However, these animals are more active and so an increase in heart rate is not wholly unexpected and could be attributed to this. Alternatively, CNP has been shown to exert a negative chronotropic effect and so mice lacking CNP could well exhibit raised heart rates. For example, CNP and cANF⁴⁻²³ reduce Langendorff-perfused mouse heart rate, and this effect is mediated via NPR-C (Rose *et al.*, 2004). Additionally, CNP enhances the bradycardic response of isolated female guinea pig atrial-right vagal nerve preparations in response to vagal nerve stimulation (Herring *et al.*, 2001). Furthermore, rats expressing a dominant-negative NPR-B mutant have raised heart rates with no change in mean arterial pressure (Langenickel *et al.*, 2006), implying that under physiological conditions NPR-B activation results in a reduction in heart rate. It is tempting to suggest that the animals in the Langenickel *et al* study

are not hypertensive because the receptor expressed and responsible for resistance artery tone is NPR-C (Chauhan *et al.*, 2003; Villar *et al.*, 2007), which should remain functional in these animals. However, it is difficult to explain why an altered heart rate would only seem to occur in males and not females (although it is possible the change in MABP may mask this); moreover, we have deleted CNP from endothelial cells specifically and it is hard to envisage how this loss may result in direct effects on heart rate.

5.5 Sex differences in cardiovascular disease

It is recognised that pre-menopausal females are less susceptible to developing CVD compared to age-matched males and post-menopausal females (Lerner and Kannel, 1986; Barrett-Connor, 1997; British Heart Foundation, 2008b). These observations provide the background to the hypothesis that female sex steroids, principally estrogens, are responsible for a sex-dependent cardioprotective effect, which may in part be due to increased endothelium-dependent vasodilatation (Mendelsohn and Karas, 2005). In ovariectomised mice (i.e. mice lacking estrogen), EDHF responses are blunted and this effect is reversed by treatment with 17 β -estradiol (Huang *et al.*, 2001; Liu *et al.*, 2002). Additionally, EDHF has been shown to be more prominent in regulating vascular tone in female mice and rats compared to their male counterparts (McCulloch and Randall, 1998; Pak *et al.*, 2002; Scotland *et al.*, 2005c). Furthermore, I have shown that females lacking CNP are hypertensive, whilst their male counterparts are not. In combination, these studies infer that estrogen promotes EDHF (and possibly CNP) activity, which may represent one mechanism by which estrogens are cardioprotective. Indeed, 16 week old ewes have double the concentration of circulating CNP compared to adult (>3 years) ewes, and estrogen treatment significantly increases circulating CNP levels in adult ewes (Prickett *et al.*, 2008). In summary, it is recognised that estrogen offers protection against CVD and it is tempting to suggest that CNP is partly responsible through its ability to regulate blood pressure, although further studies are required to determine this. It should be noted however that the ‘cardioprotective’ phenotype observed in ecCNP KO females may be peculiar to mice since male mice exhibit very little or no EDHF activity (Scotland *et al.*, 2005c), whilst in other species such as rats and guinea pigs, males do exhibit significant EDHF responses (Kamata *et al.*, 1996; Yamanaka *et al.*, 1998). Thus, if it

were possible to knockout CNP in these species, they may exhibit altered blood pressure in both sexes. It is important therefore that the role of endothelium-derived CNP is established in several animal species and more pertinently in humans, to examine if a sex difference does indeed exist and if this can be exploited therapeutically.

5.6 CNP and cardiovascular disease

I have shown CNP to promote endothelial cell proliferation and inhibit VSMC growth, both via NPR-C. Furthermore, my work has demonstrated that endogenous CNP regulates arterial reactivity, which in turn governs systemic blood pressure. These observations highlight a key role for endothelium-derived CNP in regulating vascular tone and integrity, which is critical to cardiovascular homeostasis and in preventing or slowing the onset of CVD. Since many of the salutary effects of CNP appear to occur via NPR-C, CNP and NPR-C agonists are likely to represent novel therapeutic targets in CVD.

5.6.1 Role of CNP in atherosclerosis: Potential therapy

Atherosclerosis is a chronic inflammatory disorder characterised by endothelial dysfunction, lipid deposition, monocyte and platelet activation, and VSMC growth (Ross, 1999;Libby, 2002). Various risk factors including hypertension, smoking, diabetes and dyslipidaemia have been clearly shown to correlate with increased atheroma progression (Solberg and Strong, 1983;McGill, Jr. *et al.*, 1997;Lewington *et al.*, 2002;Liapis *et al.*, 2009). CNP targets numerous aspects of atherosclerosis including hypertension, endothelial cell and VSMC growth, and leukocyte and platelet activation (Ahluwalia and Hobbs, 2005;Scotland *et al.*, 2005a;Scotland *et al.*, 2005b;this thesis), highlighting CNP as a novel therapeutic target with potential to exert a multi-faceted anti-atherogenic activity.

Normal, healthy endothelium regulates vascular tone and permeability, leukocyte adhesion, smooth muscle cell proliferation, thrombosis and fibrinolysis. Under physiological conditions, high shear stress and laminar flow maintain a healthy endothelium by stimulating expression and activity of cytoprotective molecules. Low

shear stress, exhibited by hypertensive patients (Khder *et al.*, 1998), and turbulent blood flow, found at bifurcation branches, can lead to endothelial dysfunction and subsequently atherogenesis (Ku *et al.*, 1985; Traub and Berk, 1998; Chiu *et al.*, 2009). More than 40 % of males and 30 % of females aged 16 and over had hypertension in the UK in 2006 (British Heart Foundation, 2006). Clinical observations have shown that hypertension positively correlates with atherosclerotic progression (Lakka *et al.*, 1999; Sipahi *et al.*, 2006). Herein, I have identified female ecCNP KO mice to be hypertensive, suggesting these animals may be predisposed to atherogenesis. Indeed, ApoE KO mice, a model routinely used in the study of atherosclerosis, crossed with eNOS KO mice, which are markedly hypertensive, exhibit exacerbated atherosclerosis (Knowles *et al.*, 2000; Chen *et al.*, 2001). Collectively, these observations demonstrate that hypertension promotes atheroma progression and I have shown endogenous CNP to regulate systemic blood pressure, implying CNP would be beneficial in retarding atherosclerosis due to its blood pressure altering effects. Furthermore, observations from this study implicate the vasodilator effect of CNP via NPR-C, as the primary cause in blood pressure reduction, identifying NPR-C as a potential target in blood pressure and hence CVD management.

In vitro studies have shown turbulent blood flow to increase VCAM-1 (Chappell *et al.*, 1998), ICAM-1, P-selectin and MCP-1 (Hsiai *et al.*, 2003) expression, with a reduction in eNOS expression (Ziegler *et al.*, 1998). Similar to NO, CNP expression is increased by high shear stress (Buga *et al.*, 1991; Chun *et al.*, 1997; Zhang *et al.*, 1999) suggesting in turbulent flow, hence atherosclerotic prone regions, CNP expression is reduced. This assumption correlates with the observation that endothelial cells in atherosclerotic lesions express very low levels of CNP, which inversely correlates with disease severity (Naruko *et al.*, 1996). These observations infer that CNP is anti-atherogenic and supplementation is desirable as CNP lowers blood pressure, which in turn would help maintain a physiological shear stress and thereby an anti-atherogenic state.

Another initiator of endothelial dysfunction is oxidised LDL which increases endothelial VCAM-1, ICAM-1 (Libby, 2002) and MCP-1 expression (Takahara *et al.*, 1997), promoting monocyte recruitment and migration. Oxidised LDL also reduces TGF- β -induced CNP secretion from BAEC (Sugiyama *et al.*, 1995). CNP attenuates

TNF- α -induced MCP-1 secretion from HUVEC (Weber *et al.*, 2003) and also LPS-induced MCP-1 secretion from human mesangial cells (Osawa *et al.*, 2000). In addition, CNP and cANF⁴⁻²³ reduce basal leukocyte rolling in eNOS KO mice (Scotland *et al.*, 2005b). Balloon injured rabbit coronary arteries infected with an adenovirus expressing CNP exhibit reduced VCAM-1 and ICAM-1 expression and macrophage infiltration after 7 days (Qian *et al.*, 2002). However, *in vitro*, CNP has no effect on TNF- α -induced HUVEC ICAM-1 expression or CD11b, the ICAM-1 ligand, expression on human whole blood leukocytes (Scotland *et al.*, 2005b). A possible reason for this discrepancy may be due to the length of each study, the *in vivo* versus *in vitro* nature of the studies or the species difference. Nonetheless, the above observations collectively identify CNP as being anti-inflammatory, a highly desirable property in the prophylactic treatment of CVD. To further elucidate the role of endogenous, endothelium-derived CNP on leukocyte activity, ongoing studies in our lab are assessing leukocyte activation *in vivo* in eCNP KO mice.

Intact, non-activated endothelium prevents platelet adhesion, whilst activated or damaged endothelium results in platelet adhesion (Gawaz *et al.*, 2005). Platelet-endothelial cell adhesion involves interaction of P-selectin glycoprotein ligand-1 (Frenette *et al.*, 2000) and the glycoprotein GPIb/IX/V (Romo *et al.*, 1999), on platelets, with P-selectin, present on the endothelial cell surface. This interaction is rapidly reversible and insufficient for stable adhesion. Mice lacking platelet glycoprotein GP IIb/IIIa (α_{IIb}/β_3), an integrin involved in firm platelet adhesion, exhibit reduced platelet adhesion and attenuated atherosclerotic lesion formation (Massberg *et al.*, 2005). Such studies have provided evidence suggesting that platelets contribute to the development of atherosclerosis. ApoE KO mice, as young as 6 weeks old, exhibit substantial platelet adhesion to the carotid endothelium, even in the absence of an atherosclerotic lesion (Massberg *et al.*, 2002). In addition, 6 week old ApoE KO mice treated for 12 weeks with p0p/B, an anti-GPIIb α monoclonal antibody, display reduced atherosclerotic lesion formation in atherosclerotic prone areas such as the carotid artery bifurcation, aortic sinus and coronary arteries (Massberg *et al.*, 2002). Furthermore, ApoE KO mice injected with P-selectin KO platelets exhibit a 40 % reduction in atherosclerotic lesions, in comparison to animals injected with activated wild type platelets (Huo *et al.*, 2003). Collectively the studies above have clearly identified the exacerbation of atherogenesis by platelets is, in part, P-selectin

mediated. It has been suggested that endothelium adherent platelets act as docking sites for leukocytes and activate them, thereby initiating leukocyte diapedesis (May *et al.*, 2008). CNP, and the selective NPR-C agonist, cANF⁴⁻²³, reduce histamine-induced HUVEC P-selectin expression and thrombin-induced platelet P-selectin expression (Scotland *et al.*, 2005b). This data demonstrates that CNP reduces P-selectin expression, in an NPR-C dependent manner. Thus, CNP or NPR-C agonists are likely to prove efficacious prophylactic treatments to reduce atherosclerotic lesion formation by inhibiting adherence of leukocytes and platelets to the endothelium, an initiating process in CVD. The effect of CNP on various cell adhesion molecules and their ligands on endothelial cells, leukocytes and platelets is largely unknown and so represents an area of research that is lacking to fully understand the mechanisms underlying the anti-inflammatory actions of CNP. Work in our lab is currently investigating this area using ecCNP KO mice.

Ruptured atherosclerotic lesions are characterised by thrombus formation leading to occlusion of an artery (Davi and Patrono, 2007). A well known inhibitor of fibrinolysis (breakdown of a thrombus) is plasminogen activator inhibitor (PAI)-1, which inhibits tissue plasminogen activator and urokinase, leading to reduced plasmin levels, hence reduced thrombi degradation. Various studies have demonstrated CNP to promote fibrinolysis by altering expression of factors involved in thrombus degradation. In rat aortic endothelial cells, Ang II-induced mRNA expression of tissue factor, an initiator of the coagulation cascade, and PAI-1 are suppressed by CNP (Yoshizumi *et al.*, 1999). Furthermore, in RAoSMC and human aortic smooth muscle cells, CNP reduces PAI-1 mRNA expression and protein secretion (Bouchie *et al.*, 1998). Additionally, in rabbit carotid arteries CNP reduces endothelial and neointimal PAI-1 (Kairuz *et al.*, 2005). These studies clearly demonstrate that CNP suppresses PAI-1 expression thereby promoting fibrinolysis and further still, CNP inhibits thrombin-induced platelet activation (Scotland *et al.*, 2005b) and shear stress-induced thrombosis in rabbit carotid arteries (Qian *et al.*, 2002), indicating the beneficial use of CNP in the treatment of thrombosis. In addition to the anti-fibrinolytic action of PAI-1, it is also involved in vascular remodelling and has been shown to be elevated in atherosclerotic lesions (Padro *et al.*, 1995). Human studies have yielded discordant results, with elevated plasma PAI-1 being associated with an increased or decreased risk of restenosis (Fay *et al.*, 2007). Thus, these observations intimate that CNP

reduces PAI-1 expression promoting fibrinolysis, hence reducing thrombosis, and PAI-1 may also reduce neointimal hyperplasia, highlighting CNP as a potential therapy in MI and stroke.

Neointimal hyperplasia caused by VSMC proliferation and migration is also critical to the pathophysiology of atherosclerosis (Raines and Ross, 1993). VSMC growth leads to luminal narrowing, resulting in restricted blood flow; treatments that effectively prevent this process are required. *In vitro*, CNP inhibits rat VSMC proliferation (Furuya *et al.*, 1991) and also attenuates human coronary artery smooth muscle cell (Ikeda *et al.*, 1997) and RAoSMC (Kohno *et al.*, 1997) migration. *In vivo*, CNP reduces neointimal hyperplasia in rat carotid artery and rabbit carotid, femoral and iliac artery, by as much as 90 % (Furuya *et al.*, 1993; Ueno *et al.*, 1997; Gaspari *et al.*, 2000; Doi *et al.*, 2001; Ohno *et al.*, 2002; Qian *et al.*, 2002; Yasuda *et al.*, 2002). These data clearly demonstrate the beneficial anti-mitogenic and anti-migratory properties of CNP, and in conjunction with the ability of CNP to promote endothelial cell growth, hence promoting re-endothelialisation, highlight it as a potential therapeutic target in the treatment of CVD associated with VSMC growth. Furthermore, I have established that CNP/NPR-C/ERK 1/2 activation promotes expression of the cell cycle inhibitors p21^{waf1/cip1} and p27^{kip1}, inhibiting VSMC mitogenesis, whilst in endothelial cells this pathway augments expression of the cell cycle promoter cyclin D1, stimulating growth. The identification of this pathway may prove beneficial in the design of novel NPR-C ligands, to concomitantly inhibit VSMC growth and promote endothelial cell proliferation.

In addition to the concept that VSMC are directly involved in atherosclerotic development, is the observation that vulnerable, less stable plaques contain fewer VSMC than fibrotic, stable plaques (Davies *et al.*, 1993). Plaques with a thinned fibrous cap, partly due to a loss of VSMC, are more likely to rupture leading to thrombosis and subsequently MI or stroke (Virmani *et al.*, 2000). Therefore, agents that inhibit VSMC growth could lead to thin cap atheromas, promoting plaque instability and hence increasing the risk of thrombosis. This observation suggests that compounds with anti-mitogenic VSMC effects may be detrimental in the treatment of atherosclerosis. However, statins, a routinely used class of drugs to lower plasma cholesterol with pleiotropic effects including inhibition of VSMC proliferation

(Munro *et al.*, 1994; Corsini *et al.*, 1996), have been very successful in reducing cardiovascular events. This indicates that although statins reduce VSMC growth they are still highly beneficial in the treatment of CVD, suggesting CNP would also be beneficial despite its anti-mitogenic VSMC effects.

To summarise, CNP promotes endothelial cell proliferation and inhibits leukocyte recruitment, VSMC growth, platelet adhesion and aggregation in part via NPR-C. Additionally, endothelium-derived CNP regulates blood pressure, by altering resistance arterial tone through an NPR-C dependent mechanism. These observations clearly highlight the vasoprotective actions of CNP/NPR-C activation indicating CNP or NPR-C agonists may be a potential prophylactic/treatment for atherogenesis. To further investigate the role of CNP in atherosclerosis future studies will assess atheroma development in ecCNP/ApoE KO mice.

5.6.2 Restenosis

Recurrence of intimal hyperplasia occurs within 6 months in approximately 25 % of patients who have undergone PCI and have a stent implanted (Fischman *et al.*, 1994; Serruys *et al.*, 1994). This alarming statistic emphasises the need for compounds that reduce the following aspects of restenosis: endothelial cell damage, VSMC growth and leukocyte and platelet activation. Drug eluting stents (DES) have been developed which release agents (e.g. rapamycin/sirolimus) with anti-proliferative and immunosuppressive actions that have been successful in reducing the rate of restenosis to <10 % (Morice *et al.*, 2007), however, the complication of stent thrombosis remains.

Stent thrombosis occurring post PCI is categorised as early stent thrombosis, occurring 0 - 30 days post PCI, late stent thrombosis, occurring >30 days to 1 year post PCI or very late stent thrombosis, occurring >1 year post PCI (Cutlip *et al.*, 2007). Stent thrombosis occurs in patients treated with BMS and DES, however in the Basel Stent Kosten Effektivitats Trial (BASKET) the rate of late stent thrombosis was double in patients treated with DES in comparison to BMS, 2.6 % vs 1.3 % respectively (Pfisterer *et al.*, 2006). These data highlight that current agents released

from DES are not ideal as they are associated with increased rates of thrombosis, a life threatening process.

Current DES release agents that inhibit VSMC proliferation and migration, a beneficial action in reducing the incidence of restenosis, and also inhibit endothelial cell proliferation (Parry *et al.*, 2005;Matter *et al.*, 2006), an unwanted effect. Balloon angioplasty and stent deployment cause endothelial denudation, exposing thrombogenic material to the blood, which can lead to thrombosis (Schwartz and Vaitkus, 2003;Stahli *et al.*, 2009). Following PCI, endothelial cell denudation may give rise to stent thrombosis, particularly in patients treated with a DES, as the agents eluted from the stent impair endothelial regeneration. *In vitro*, rapamycin, an agent currently used, suppresses endothelial cell proliferation and migration (Matter *et al.*, 2006) and also inhibits human endothelial progenitor cell proliferation and differentiation (Butzal *et al.*, 2004), which have been shown to be involved in re-endothelialisation (Blindt *et al.*, 2006). Therefore, current drugs released from stents impair vascular healing due to impaired endothelial cell and endothelial progenitor cell function. These observations highlight the critical need for agents with anti-mitogenic VSMC effects, but with pro-proliferative effects on endothelial cells, in order to ensure rapid healing of the endothelium to maintain an anti-thrombotic and anti-inflammatory surface.

CNP would be an ideal candidate to be released from DES as it promotes endothelial cell proliferation, inhibits VSMC proliferation, has anti-inflammatory and anti-thrombotic properties (Figure 60). As described previously, following angioplasty in rabbit carotid artery, rabbit femoral artery and porcine femoral artery, CNP treatment inhibits neointimal thickening (Gaspari *et al.*, 2000;Doi *et al.*, 2001;Qian *et al.*, 2002;Fuchs *et al.*, 2008) and accelerates re-endothelialisation (Doi *et al.*, 1996;Ohno *et al.*, 2002;Qian *et al.*, 2002). Furthermore, work from our lab has identified NPR-C/ERK 1/2 signalling as mediating the growth altering effects of CNP (Panayiotou, 2007; Chapter 3). The unique mitogenic profile of CNP, mediated by NPR-C, identifies both as therapeutic targets in the treatment of restenosis.

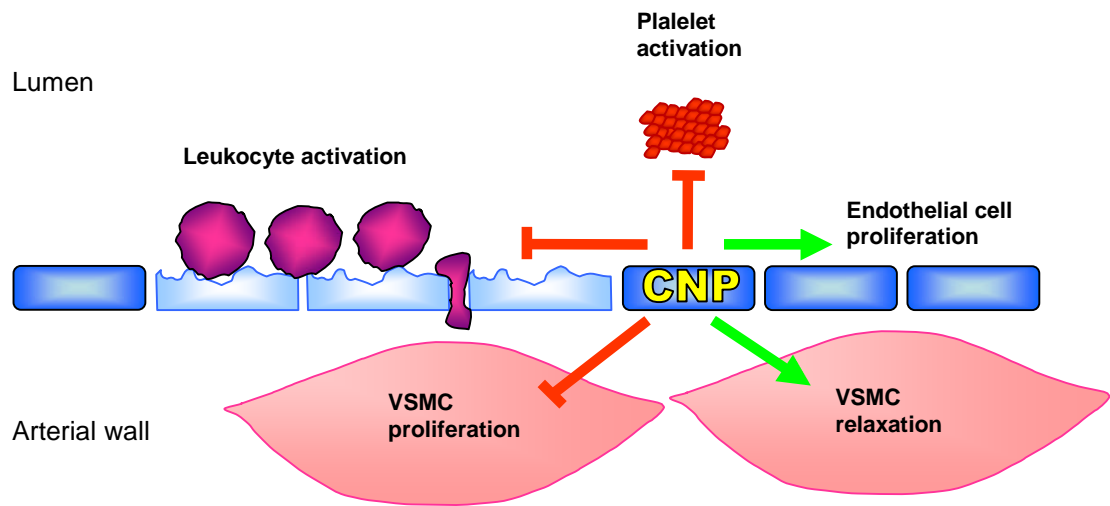

Figure 60 - The beneficial actions of endothelium-derived CNP

CNP - C-type natriuretic peptide, VSMC - Vascular smooth muscle cell

5.6.3 Vein graft disease prevention

Vein grafts are used for auto transplantation in patients requiring coronary artery bypass surgery. When adequate arterial grafts are not available, a saphenous vein graft is commonly used due to ease of harvestation and plentiful supply. Unfortunately, following a procedure, vein graft disease can occur, which is comprised of three discrete processes: thrombosis, intimal hyperplasia and atherosclerosis (Motwani and Topol, 1998). Within the first month, approximately 13 % of saphenous vein grafts occlude, principally due to thrombosis (Bourassa *et al.*, 1982;Fitzgibbon *et al.*, 1996). The major disease process in saphenous vein grafts between one month and one year is intimal hyperplasia, affecting approximately 10 % of grafts (Bourassa *et al.*, 1982;Fitzgibbon *et al.*, 1996) and so patency after 1 year is approximately 75 %. One year post surgery, atherosclerosis is the dominant disease, leading to attrition of saphenous vein grafts, leaving the 10 year saphenous vein graft patency at 50 - 60 % (Fitzgibbon *et al.*, 1996;Hassantash *et al.*, 2008).

All three processes have been shown to be attenuated by CNP therapy and a few studies have looked at these processes in the context of vein graft disease. CNP has been shown to reduce intimal hyperplasia and CD8-positive cells in a mouse model of vein graft disease, in which the inferior vena cava is interposed into the common

carotid artery (Schachner *et al.*, 2004). Furthermore, CNP promotes reendothelialisation and suppresses neointimal hyperplasia and thrombosis in rabbit jugular vein grafts interposed into the carotid artery (Ohno *et al.*, 2002). These studies clearly demonstrate CNP to be effective in suppressing thrombosis and neointimal hyperplasia, two of the main processes involved in vein graft disease and hence identifies CNP as a potential therapy. As discussed previously (section 1.4.5) the receptor thought to be responsible for the anti-aggregatory effect is NPR-C, which has also been shown to be responsible for the anti-mitogenic VSMC effect, therefore suggesting NPR-C agonists would be beneficial in vein graft disease prevention.

5.6.4 Ischaemia/reperfusion injury

Ischaemia/reperfusion (I/R) injury occurs when ischaemic tissue is reperfused i.e. blood flow is restored. Restoration of blood flow to ischaemic tissue is vital in order to protect from organ damage; however, paradoxically reperfusion itself can result in tissue damage greater than the initial insult. This situation arises during MI, stroke and also during surgery where vessels are clamped during transplant surgery. I/R injury is characterised by microvascular dysfunction, most notably a reduction in endothelium-derived NO, leading to an inflammatory response, typified by increased leukocyte activation, cellular and fluid extravasation, capillary constriction and decreased perfusion (Carden and Granger, 2000). Mice deficient in P-selectin and ICAM-1 subjected to I/R injury do not exhibit impaired endothelium-dependent vasodilatation unlike wild type mice, suggesting a role for activated leukocytes in I/R injury (Banda *et al.*, 1997).

There is increasing evidence to suggest CNP may be a beneficial treatment, post MI, to reduce cardiac hypertrophy and remodelling. In an experimental model of MI in rats, CNP reduces myocardial hypertrophy and collagen volume, 2 weeks post MI, with no effect upon blood pressure (Soeki *et al.*, 2005). A further study has shown 3 weeks post I/R-induced MI cardiomyocyte restricted overexpression of CNP in mice resulted in a reduction of ventricular hypertrophy, functional impairment of cardiac tissue, necrosis and inflammation, compared to WT (Wang *et al.*, 2007). The anti-hypertrophic effect of CNP is most likely NPR-B mediated as rats expressing a dominant negative NPR-B exhibit reduced cGMP and cardiac hypertrophy

(Langenickel *et al.*, 2006). Work from our lab has shown CNP and cANF⁴⁻²³ reduce infarct size in the Langendorff isolated rat heart when administered pre- or post-reperfusion, following ischaemia (Hobbs *et al.*, 2004).

Chronic heart failure patients produce CNP in the myocardium suggesting a role for CNP (Kalra *et al.*, 2003) in cardiac fibrosis. *In vitro* studies have shown CNP to be synthesised in rat cardiac fibroblasts in response to TGF- β , ET-1 and bFGF, all of which promote cardiac fibrosis, suggesting CNP may counter this pathology. Indeed, CNP inhibits DNA and collagen synthesis (Horio *et al.*, 2003), intimating it directly reduces cardiac fibrosis. Collectively these observations highlight the ability of CNP, most likely through a combination of NPR-B and -C, to prevent MI-induced cardiac hypertrophy and fibrosis advocating CNP therapy in ischaemic CVD.

5.7 Angiogenesis and revascularisation

Angiogenesis is a physiological process involving the growth of new vessels which is vital in numerous conditions such as tumour growth, wound healing and revascularisation. It is an endothelium-centred response to hypoxia that promotes migration and proliferation of endothelial cells to sprout new capillaries from existing blood vessels, a process which is predominantly initiated by hypoxia inducible factor (HIF)1 α , that in turn transcriptionally activates genes including VEGF, PDGF, bFGF and angiopoietins (Distler *et al.*, 2003; Simons, 2004; Simons, 2005).

Several reports in the literature suggest that CNP can mobilise endothelial cells and promote re-endothelialisation of damaged blood vessels, consistent with a pro-angiogenic activity. CNP promotes re-endothelialisation following balloon angioplasty (Ueno *et al.*, 1997; Morishige *et al.*, 2000; Doi *et al.*, 2001; Kuhnle *et al.*, 2005) and in vein grafts (Ohno *et al.*, 2002). Furthermore, *in vitro*, CNP promotes capillary network formation of HUVEC and in mice subjected to hindlimb ischaemia (Yamahara *et al.*, 2003). Additionally, CNP expression is increased in human coronary atherosclerotic lesions (Naruko *et al.*, 1996) and in the neointima following PCI (Naruko *et al.*, 2005). In combination, these observations intimate that CNP is produced endogenously in response to vessel injury, which may be beneficial in revascularisation.

It is plausible to suggest that the angiogenic effect of CNP may be via VEGF as ANP has been suggested to promote angiogenesis through VEGF. ANP increases mRNA expression of VEGF in HUVEC (Tokudome *et al.*, 2009) and lung extracts from NPR-A KO mice exhibit reduced VEGF expression in comparison to WT (Kong *et al.*, 2008) suggesting ANP or BNP can physiologically increase VEGF secretion. Studies investigating angiogenesis in our novel ecCNP KO mouse model are required to elucidate if endothelium-derived CNP is involved in neovascularisation.

5.8 Interaction between nitric oxide and CNP in the vasculature

Endothelium-derived NO, PGI₂ and EDHF are important regulators of vascular homeostasis. As discussed earlier and highlighted in this thesis, CNP is an EDHF in the rat and mouse mesenteric artery (Chauhan *et al.*, 2003; Villar *et al.*, 2007). It has been suggested that EDHF is up-regulated to compensate for a lack of NO bioactivity (Huang *et al.*, 2000; Scotland *et al.*, 2001), which can occur in CVD due to the oxidative environment.

It has been demonstrated that the natriuretic peptide and NO systems can modulate each other such that if one is down-regulated the other is up-regulated (Hussain *et al.*, 2001; Madhani *et al.*, 2003; Madhani *et al.*, 2006). The potency of ANP and CNP in aortae from eNOS KO mice is greater than that from WT mice. Also the potency of ANP and CNP is decreased in aortae from eNOS KO mice treated with supramaximal concentrations of glyceryl trinitrate, an NO donor, but increased in aortae from WT mice pretreated with L-NAME (Madhani *et al.*, 2003). In addition, I have shown NO to be more sensitive in aorta from ecCNP KO mice compared to WT animals. Furthermore, CNP reduces coronary perfusion pressure in an infarct model of I/R injury, which is enhanced by L-NAME treatment (Hobbs *et al.*, 2004). In sum, these data allude to the hypothesis that a compensatory mechanism exists whereby if the level of NO is reduced, as occurs in CVD, there is an up-regulation of the natriuretic peptide signalling pathway.

Studies suggest that NO may also have a role in CNP-mediated vasorelaxant activity in certain vascular beds. For instance, CNP has been shown to dilate rat juxtamedullary arterioles, precontracted with noradrenaline, in a NO-dependent manner (Amin *et al.*, 1996). Additionally, CNP causes a reduction in rat coronary perfusion pressure with a corresponding increase in cGMP that is reduced in the presence of L-NNA (Brunner and Wolkart, 2001). This observation suggests that in the rat coronary vasculature CNP-mediated dilation is dependent upon NO. These observations suggest that CNP mediated relaxation via NO may occur in some species in some vascular beds, although it is unknown whether this is due to an increase in NOS expression or NO synthesis. CNP infusion in rats attenuates MABP with an increase in urinary excretion of NO metabolites (Costa *et al.*, 2007). The authors found iNOS and nNOS levels were undetectable and there was no change in eNOS expression in aorta, right atrium or left ventricle (Costa *et al.*, 2007), however there was increased NOS activity in all 3 tissues, suggesting CNP increases eNOS activity. Additionally, CNP has been shown to decrease VCAM-1 and ICAM-1 expression, macrophage infiltration and neointimal formation following balloon angioplasty which is reduced by L-NAME treatment and accompanied by an increase in iNOS expression (Qian *et al.*, 2002). Collectively, the above observations highlight the possibility that some of the vasoprotective actions of CNP may be mediated via NO, although further studies are required to ascertain if this hypothesis is correct.

5.9 Conclusions

Herein, I have identified the receptor, signalling pathway and downstream targets by which CNP alters mitogenesis of endothelial and smooth muscle cells. CNP enhances endothelial cell growth in an NPR-C dependent manner, leading to ERK 1/2 phosphorylation, initiating up-regulation of cyclin D1 and down-regulation of p21^{waf1/cip1}, resulting in proliferation. In contrast, CNP-induced NPR-C activation, in smooth muscle cells, leads to ERK 1/2 activation, which in turn augments p21^{waf1/cip1} and p27^{kip1} expression, thereby preventing growth. Thus, I have identified NPR-C/ERK 1/2 signalling as key in mediating the differential mitogenic effects of CNP in endothelial and smooth muscle cells.

Additionally, I have demonstrated that in female mice CNP is involved in physiological blood pressure regulation. Female mice lacking endothelial CNP are hypertensive and exhibit altered vascular reactivity, most notably in resistance arteries, whilst male mice are normotensive. These observations provide support to the hypotheses that CNP is important in maintaining physiological blood pressure and that CNP is an EDHF, which may underlie the cardioprotective phenotype of females.

In sum, my thesis provides strong evidence for CNP/NPR-C signal transduction as a key pathway in mediating the anti-atherogenic properties of this vasoprotective peptide. Further, my data highlights the therapeutic potential of this pathway in a variety of cardiovascular disorders including atherosclerosis and restenosis.

Chapter 6

References

6 References

Abe,A. and Karaki,H. (1992). Mechanisms underlying the inhibitory effect of dibutyryl cyclic AMP in vascular smooth muscle. *European Journal of Pharmacology*, 211, 305-311.

Ahluwalia,A., Foster,P., Scotland,R.S., McLean,P.G., Mathur,A., Perretti,M., Moncada,S., and Hobbs,A.J. (2004). Antiinflammatory activity of soluble guanylate cyclase: cGMP-dependent down-regulation of P-selectin expression and leukocyte recruitment. *Proceedings of the National Academy of Sciences of the United States of America*, 101, 1386-1391.

Ahluwalia,A. and Hobbs,A.J. (2005). Endothelium-derived C-type natriuretic peptide: more than just a hyperpolarizing factor. *Trends in Pharmacological Sciences*, 26, 162-167.

Aizawa,N., Ishizuka,O., Ogawa,T., Mizusawa,H., Igawa,Y., Nishizawa,O., and Andersson,K.E. (2008). Effects of natriuretic peptides on intracavernous pressure and blood pressure in conscious rats. *Journal of Sexual Medicine*, 5, 2312-2317.

Alessi,D.R., Andjelkovic,M., Caudwell,B., Cron,P., Morrice,N., Cohen,P., and Hemmings,B.A. (1996). Mechanism of activation of protein kinase B by insulin and IGF-1. *European Molecular Biology Organization Journal*, 15, 6541-6551.

Amin,J., Carretero,O.A., and Ito,S. (1996). Mechanisms of Action of Atrial Natriuretic Factor and C-Type Natriuretic Peptide. *Hypertension*, 27, 684-687.

Anand-Srivastava,M.B. (2005). Natriuretic peptide receptor-C signaling and regulation. *Peptides*, 26, 1044-1059.

Atarashi,K., Mulrow,P.J., Franco-Saenz,R., Snajdar,R., and Rapp,J. (1984). Inhibition of aldosterone production by an atrial extract. *Science*, 224, 992-994.

Banda,M.A., Lefer,D.J., and Granger,D.N. (1997). Postischemic endothelium-dependent vascular reactivity is preserved in adhesion molecule-deficient mice. *American Journal of Physiology - Heart and Circulatory Physiology*, 273, H2721-H2725.

Barber,D.A., Burnett,J.C., Fitzpatrick,L.A., Sieck,G.C., and Miller,V.M. (1998). Gender and relaxation to C-type natriuretic peptide in porcine coronary arteries. *Journal of Cardiovascular Pharmacology*, 32, 5-11.

Barletta,G., Lazzeri,C., Vecchiarino,S., Del Bene,R., Messeri,G., lo Sbarba,A., Mannelli,M., and La Villa,G. (1998). Low-Dose C-Type Natriuretic Peptide Does Not Affect Cardiac and Renal Function in Humans. *Hypertension*, 31, 802-808.

Barrett-Connor,E. (1997). Sex Differences in Coronary Heart Disease: Why Are Women So Superior? The 1995 Ancel Keys Lecture. *Circulation*, 95, 252-264.

Bauer,P.M., Buga,G.M., and Ignarro,L.J. (2001). Role of p42/p44 mitogen-activated-protein kinase and p21waf1/cip1 in the regulation of vascular smooth muscle cell

proliferation by nitric oxide. *Proceedings of the National Academy of Sciences*, 98, 12802-12807.

Bauersachs,J., Popp,R., Hecker,M., Sauer,E., Fleming,I., and Busse,R. (1996). Nitric Oxide Attenuates the Release of Endothelium-Derived Hyperpolarizing Factor. *Circulation*, 94, 3341-3347.

Baxter,G.F. (2004). The natriuretic peptides. *Basic Research in Cardiology*, 99, 71-75.

Bennett,B.D., Bennett,G.L., Vitangcol,R.V., Jewett,J.R., Burnier,J., Henzel,W., and Lowe,D.G. (1991). Extracellular domain-IgG fusion proteins for three human natriuretic peptide receptors. Hormone pharmacology and application to solid phase screening of synthetic peptide antisera. *Journal of Biological Chemistry*, 266, 23060-23067.

Blaise,V., Wolf,J.P., Regnard,J., and Berthelay,S. (1996). Characterization of human platelet receptors for atrial natriuretic peptide: evidence for clearance receptors. *Cellular and Molecular Biology*, 42, 1173-1179.

Blankenberg,S., Barbaux,S., and Tiret,L. (2003). Adhesion molecules and atherosclerosis. *Atherosclerosis*, 170, 191-203.

Blindt,R., Vogt,F., Astafieva,I., Fach,C., Hristov,M., Krott,N., Seitz,B., Kapurniotu,A., Kwok,C., Dewor,M., Bosserhoff,A.K., Bernhagen,J., Hanrath,P., Hoffmann,R., and Weber,C. (2006). A Novel Drug-Eluting Stent Coated With an Integrin-Binding Cyclic Arg-Gly-Asp Peptide Inhibits Neointimal Hyperplasia by Recruiting Endothelial Progenitor Cells. *Journal of the American College of Cardiology*, 47, 1786-1795.

Bohm,F. and Pernow,J. (2007). The importance of endothelin-1 for vascular dysfunction in cardiovascular disease. *Cardiovascular Research*, 76, 8-18.

Boring,L., Gosling,J., Cleary,M., and Charo,I.F. (1998). Decreased lesion formation in CCR2^{-/-} mice reveals a role for chemokines in the initiation of atherosclerosis. *Nature*, 394, 894-897.

Bouchie,J.L., Hansen,H., and Feener,E.P. (1998). Natriuretic Factors and Nitric Oxide Suppress Plasminogen Activator Inhibitor-1 Expression in Vascular Smooth Muscle Cells : Role of cGMP in the Regulation of the Plasminogen System. *Arteriosclerosis, Thrombosis and Vascular Biology*, 18, 1771-1779.

Bourassa,M.G., Campeau,L., Lesperance,J., and Grondin,C.M. (1982). Changes in grafts and coronary arteries after saphenous vein aortocoronary bypass surgery: results at repeat angiography. *Circulation*, 65, 90-97.

Brader,S. and Eccles,S.A. (2004). Phosphoinositide 3-kinase signalling pathways in tumor progression, invasion and angiogenesis. *Tumori*, 90, 2-8.

Brandes,R.P., Schmitz-Winnenthal,F.H., Feletou,M., Gedecke,A., Huang,P.L., Vanhoutte,P.M., Fleming,I., and Busse,R. (2000). An endothelium-derived hyperpolarizing factor distinct from NO and prostacyclin is a major endothelium-dependent vasodilator in resistance vessels of wild-type and endothelial NO synthase

knockout mice. *Proceedings of the National Academy of Sciences of the United States of America*, 97, 9747-9752.

British Heart Foundation. (2008a). Coronary heart disease statistics 2008: Treatment. *British Heart Foundation*. <http://www.heartstats.org/temp/2008.chaptersp3.pdf>.

British Heart Foundation. (2008b). Coronary heart disease statistics 2008: Mortality. *British Heart Foundation*. <http://www.heartstats.org/temp/2008.Chaptersp1.pdf>.

British Heart Foundation. (2006). Prevalence of high blood pressure by sex and age, adults aged 16 and over, 1998 to 2006, England. *British Heart Foundation*. <http://www.heartstats.org/temp/Tabsp9.2spweb08.xls>.

Brunner,F. and Wolkart,G. (2001). Relaxant effect of C-type natriuretic peptide involves endothelium and nitric oxide-cGMP system in rat coronary microvasculature. *Cardiovascular Research*, 51, 577-584.

Buga,G.M., Gold,M.E., Fukuto,J.M., and Ignarro,L.J. (1991). Shear stress-induced release of nitric oxide from endothelial cells grown on beads. *Hypertension*, 17, 187-193.

Burnett,J.C., Granger,J.P., and Opgenorth,T.J. (1984). Effects of synthetic atrial natriuretic factor on renal function and renin release. *American Journal of Physiology - Renal Physiology*, 247, F863-F866.

Busse,R., Edwards,G., Feletou,M., Fleming,I., Vanhoutte,P.M., and Weston,A.H. (2002). EDHF: bringing the concepts together. *Trends in Pharmacological Sciences*, 23, 374-380.

Butzal,M., Loges,S., Schweizer,M., Fischer,U., Gehling,U.M., Hossfeld,D.K., and Fiedler,W. (2004). Rapamycin inhibits proliferation and differentiation of human endothelial progenitor cells in vitro. *Experimental Cell Research*, 300, 65-71.

Cahill,P.A. and Hassid,A. (1994). ANF-C-receptor-mediated inhibition of aortic smooth muscle cell proliferation and thymidine kinase activity. *American Journal of Physiology - Regulatory, Integrative and Comparative Physiology*, 266, R194-R203.

Carden,D.L. and Granger,D.N. (2000). Pathophysiology of ischaemia-reperfusion injury. *Journal of Pathology*, 190, 255-266.

Cargill,R.I., Struthers,A.D., and Lipworth,B.J. (1995). Human C-type natriuretic peptide: effects on the haemodynamic and endocrine responses to angiotensin II. *Cardiovascular Research*, 29, 108-111.

Casco,V.H., Veinot,J.P., de Bold,M.L.K., Masters,R.G., Stevenson,M.M., and de Bold,A.J. (2002). Natriuretic Peptide System Gene Expression in Human Coronary Arteries. *Journal of Histochemistry and Cytochemistry*, 50, 799-810.

Chambard,J.C., Lefloch,R., Pouyssegur,J., and Lenormand,P. (2007). ERK implication in cell cycle regulation. *Biochimica et Biophysica Acta - Molecular Cell Research*, 1773, 1299-1310.

Chappell,D.C., Varner,S.E., Nerem,R.M., Medford,R.M., and Alexander,R.W. (1998). Oscillatory Shear Stress Stimulates Adhesion Molecule Expression in Cultured Human Endothelium. *Circulation Research*, 82, 532-539.

Chauhan,S.D., Nilsson,H., Ahluwalia,A., and Hobbs,A.J. (2003). Release of C-type natriuretic peptide accounts for the biological activity of endothelium-derived hyperpolarizing factor. *Proceedings of the National Academy of Sciences*, 100, 1426-1431.

Chen,J., Kuhlencordt,P.J., Astern,J., Gyurko,R., and Huang,P.L. (2001). Hypertension Does Not Account for the Accelerated Atherosclerosis and Development of Aneurysms in Male Apolipoprotein E/Endothelial Nitric Oxide Synthase Double Knockout Mice. *Circulation*, 104, 2391-2394.

Chen,Y., Zheng,J., Zhang,Y., Wang,J., Liu,Q., Huang,Z., Gao,F., Zhou,Y., and Shi,G. (2009). N-4-tert-butyl benzyl haloperidol chloride suppresses Ca²⁺-dependent Egr-1 expression and subsequently inhibits vascular smooth muscle cell proliferation induced by angiotensin II. *Cellular Physiology and Biochemistry*, 23, 295-304.

Chinkers,M., Garbers,D.L., Chang,M.S., Lowe,D.G., Chin,H.M., Goeddel,D.V., and Schulz,S. (1989). A membrane form of guanylate cyclase is an atrial natriuretic peptide receptor. *Nature*, 338, 78-83.

Chiou,W.F., Chen,C.C., and Wei,B.L. (2009). 3,4-Di-O-Caffeoylquinic Acid Inhibits Angiotensin-II-induced Vascular Smooth Muscle Cell Proliferation and Migration by Downregulating the JNK and PI3K/Akt Signaling Pathways. *Evidence-based Complementary and Alternative Medicine*, nep140.

Chiu,J.J., Usami,S., and Chien,S. (2009). Vascular endothelial responses to altered shear stress: pathologic implications for atherosclerosis. *Annals of Medicine*, 41, 19-28.

Choi,K.H., Kim,J.E., Song,N.R., Son,J.E., Hwang,M.K., Byun,S., Kim,J.H., Lee,K.W., and Lee,H.J. (2010). Phosphoinositide 3-kinase is a novel target of piceatannol for inhibiting PDGF-BB-induced proliferation and migration in human aortic smooth muscle cells. *Cardiovascular Research*, 85, 836-844.

Chun,T.H., Itoh,H., Saito,T., Yamahara,K., Doi,K., Mori,Y., Ogawa,Y., Yamashita,J., Tanaka,T., Inoue,M., Masatsugu,K., Sawada,N., Fukunaga,Y., and Nakao,K. (2000). Oxidative stress augments secretion of endothelium-derived relaxing peptides, C-type natriuretic peptide and adrenomedullin. *Journal of Hypertension*, 18, 575-580.

Chun,T.H., Itoh,H., Ogawa,Y., Tamura,N., Takaya,K., Igaki,T., Yamashita,J., Doi,K., Inoue,M., Masatsugu,K., Korenaga,R., Ando,J., and Nakao,K. (1997). Shear Stress Augments Expression of C-Type Natriuretic Peptide and Adrenomedullin. *Hypertension*, 29, 1296-1302.

Chung,B.H., Cho,Y.L., Kim,J.D., Jo,H.S., Won,M.H., Lee,H., Ha,K.S., Kwon,Y.G., and Kim,Y.M. (2010a). Promotion of direct angiogenesis in vitro and in vivo by Puerariae flos extract via activation of MEK/ERK-, PI3K/Akt/eNOS-, and Src/FAK-dependent pathways. *Phytotherapy Research*, 24, 934-940.

Chung,B.H., Kim,J.D., Kim,C.K., Kim,J.H., Won,M.H., Lee,H.S., Dong,M.S., Ha,K.S., Kwon,Y.G., and Kim,Y.M. (2008). Icariin stimulates angiogenesis by activating the MEK/ERK- and PI3K/Akt/eNOS-dependent signal pathways in human endothelial cells. *Biochemical and Biophysical Research Communications*, 376, 404-408.

Chung,B.H., Lee,J.J., Kim,J.D., Jeoung,D., Lee,H., Choe,J., Ha,K.S., Kwon,Y.G., and Kim,Y.M. (2010b). Angiogenic activity of sesamin through the activation of multiple signal pathways. *Biochemical and Biophysical Research Communications*, 391, 254-260.

Cipollone,F., Marini,M., Fazia,M., Pini,B., Iezzi,A., Reale,M., Paloscia,L., Materazzo,G., D'Annunzio,E., Conti,P., Chiarelli,F., Cuccurullo,F., and Mezzetti,A. (2001). Elevated Circulating Levels of Monocyte Chemoattractant Protein-1 in Patients With Restenosis After Coronary Angioplasty. *Arteriosclerosis, Thrombosis and Vascular Biology*, 21, 327-334.

Clapp,L.H. and Gurney,A.M. (1991). Modulation of calcium movements by nitroprusside in isolated vascular smooth muscle cells. *Pflugers Archive*, 418, 462-470.

Clavell,A.L., Stingo,A.J., Wei,C.M., Heublein,D.M., and Burnett,J.C. (1993). C-type natriuretic peptide: a selective cardiovascular peptide. *American Journal of Physiology - Regulatory, Integrative and Comparative Physiology*, 264, R290-R295.

Coffer,P.J., Jin,J., and Woodgett,J.R. (1998). Protein kinase B (c-Akt): a multifunctional mediator of phosphatidylinositol 3-kinase activation. *Journal of Biochemistry*, 335, 1-13.

Cohen,D., Koh,G.Y., Nikonova,L.N., Porter,J.G., and Maack,T. (1996). Molecular Determinants of the Clearance Function of Type C Receptors of Natriuretic Peptides. *Journal of Biological Chemistry*, 271, 9863-9869.

Connelly,L., Madhani,M., and Hobbs,A.J. (2005). Resistance to Endotoxic Shock in Endothelial Nitric-oxide Synthase (eNOS) Knock-out Mice. *Journal of Biological Chemistry*, 280, 10040-10046.

Corsini,A., Pazzucconi,F., Pfister,P., Paoletti,R., and Sirtori,C.R. (1996). Inhibitor of proliferation of arterial smooth-muscle cells by fluvastatin. *The Lancet*, 348, 1584.

Costa,M.A., Elesgaray,R., Caniffi,C., Fellet,A., and Arranz,C. (2007). Role of cardiovascular nitric oxide system in C-type natriuretic peptide effects. *Biochemical and Biophysical Research Communications*, 359, 180-186.

Currie,M.G., Geller,D.M., Cole,B.R., Boylan,J.G., YuSheng,W., Holmberg,S.W., and Needleman,P. (1983). Bioactive cardiac substances: potent vasorelaxant activity in mammalian atria. *Science*, 221, 71-73.

Cutlip,D.E., Windecker,S., Mehran,R., Boam,A., Cohen,D.J., Van Es,G.A., Gabriel Steg,P., Morel,M.a., Mauri,L., Vranckx,P., McFadden,E., Lansky,A., Hamon,M., Krucoff,M.W., Serruys,P.W., and on behalf of the Academic Research Consortium

(2007). Clinical End Points in Coronary Stent Trials: A Case for Standardized Definitions. *Circulation*, 115, 2344-2351.

Cybulsky,M.I., Iiyama,K., Li,H., Zhu,S., Chen,M., Iiyama,M., Davis,V., Gutierrez-Ramos,J.C., Connelly,P.W., and Milstone,D.S. (2001). A major role for VCAM-1, but not ICAM-1, in early atherosclerosis. *Journal of Clinical Investigation*, 107, 1255-1262.

Davi,G. and Patrono,C. (2007). Platelet Activation and Atherothrombosis. *New England Journal of Medicine*, 357, 2482-2494.

Davies,M.J., Richardson,P.D., Woolf,N., Katz,D.R., and Mann,J. (1993). Risk of thrombosis in human atherosclerotic plaques: role of extracellular lipid, macrophage, and smooth muscle cell content. *British Heart Journal*, 69, 377-381.

Davignon,J. and Ganz,P. (2004). Role of Endothelial Dysfunction in Atherosclerosis. *Circulation*, 109, 27-32.

de Bold,A.J., Borenstein,H.B., Veress,A.T., and Sonnenberg,H. (1981). A rapid and potent natriuretic response to intravenous injection of atrial myocardial extract in rats. *Life Sciences*, 28, 89-94.

Del Ry,S., Maltinti,M., Piacenti,M., Passino,C., Emdin,M., and Giannessi,D. (2006). Cardiac production of C-type natriuretic peptide in heart failure. *Journal of Cardiovascular Medicine*, 7, 397-399.

Department of Health. (2008). The Coronary Heart Disease National Framework Service: Progress Report for 2008. *Department of Health*. http://www.dh.gov.uk/prod_consum_dh/groups/dh_digitalassets/documents/digitalasset/dh_096556.pdf.

Dimmeler,S., Fleming,I., Fisslthaler,B., Hermann,C., Busse,R., and Zeiher,A.M. (1999). Activation of nitric oxide synthase in endothelial cells by Akt-dependent phosphorylation. *Nature*, 399, 601-605.

Distler,J.H., Hirth,A., Kurowska-Stolarska,M., Gay,R.E., Gay,S., and Distler,O. (2003). Angiogenic and angiostatic factors in the molecular control of angiogenesis. *Quarterly Journal of Nuclear Medicine*, 47, 149-161.

Doi,K., Ikeda,T., Itoh,H., Ueyama,K., Hosoda,K., Ogawa,Y., Yamashita,J., Chun,T.H., Inoue,M., Masatsugu,K., Sawada,N., Fukunaga,Y., Saito,T., Sone,M., Yamahara,K., Kook,H., Komeda,M., Ueda,M., and Nakao,K. (2001). C-Type Natriuretic Peptide Induces Redifferentiation of Vascular Smooth Muscle Cells With Accelerated Reendothelialization. *Arteriosclerosis, Thrombosis and Vascular Biology*, 21, 930-936.

Doi,K., Itoh,H., Ikeda,T., Hosoda,K., Ogawa,Y., Igaki,T., Yamashita,J., Chun,T.H., Inoue,M., Masatsugu,K., Matsuda,K., Ohmori,K., and Nakao,K. (1997). Adenovirus-Mediated Gene Transfer of C-Type Natriuretic Peptide Causes G1 Growth Inhibition of Cultured Vascular Smooth Muscle Cells. *Biochemical and Biophysical Research Communications*, 239, 889-894.

Doi,K., Itoh,H., Komatsu,Y., Igaki,T., Chun,T.H., Takaya,K., Yamashita,J., Inoue,M., Yoshimasa,T., and Nakao,K. (1996). Vascular Endothelial Growth Factor Suppresses C-Type Natriuretic Peptide Secretion. *Hypertension*, 27, 811-815.

Dong,Z.M., Chapman,S.M., Brown,A.A., Frenette,P.S., Hynes,R.O., and Wagner,D.D. (1998). The combined role of P- and E-selectins in atherosclerosis. *Journal of Clinical Investigation*, 102, 145-152.

Drewett,J.G., Fendly,B.M., Garbers,D.L., and Lowe,D.G. (1995). Natriuretic Peptide Receptor-B (Guanylyl Cyclase-B) Mediates C-type Natriuretic Peptide Relaxation of Precontracted Rat Aorta. *Journal of Biological Chemistry*, 270, 4668-4674.

Erdos,E.G. and Skidgel,R.A. (1989). Neutral endopeptidase 24.11 (enkephalinase) and related regulators of peptide hormones. *The Journal of the Federation of American Societies for Experimental Biology*, 3, 145-151.

Fagny,C., Michel,A., Leonard,I., Berkenboom,G., Fontaine,J., and schodt-Lanckman,M. (1991). In vitro degradation of endothelin-1 by endopeptidase 24.11 (enkephalinase). *Peptides*, 12, 773-778.

Favot,L., Keravis,T., and Lugnier,C. (2004). Modulation of VEGF-induced endothelial cell cycle protein expression through cyclic AMP hydrolysis by PDE2 and PDE4. *Journal of Thrombosis and Haemostasis*, 92, 634-645.

Fay,W.P., Garg,N., and Sunkar,M. (2007). Vascular Functions of the Plasminogen Activation System. *Arteriosclerosis, Thrombosis and Vascular Biology*, 27, 1231-1237.

Feletou,M. and Vanhoutte,P.M. (2009). EDHF: an update. *Clinical Science*, 117, 139-155.

Fetalvero,K.M., Martin,K.A., and Hwa,J. (2007). Cardioprotective prostacyclin signaling in vascular smooth muscle. *Prostaglandins Other Lipid Mediat.*, 82, 109-118.

Fischman,D.L., Leon,M.B., Baim,D.S., Schatz,R.A., Savage,M.P., Penn,I., Detre,K., Veltri,L., Ricci,D., Nobuyoshi,M., Cleman,M., Heuser,R., Almond,D., Teirstein,P.S., Fish,R.D., Colombo,A., Brinker,J., Moses,J., Shaknovich,A., Hirshfeld,J., Bailey,S., Ellis,S., Rake,R., and Goldberg,S. (1994). A Randomized Comparison of Coronary-Stent Placement and Balloon Angioplasty in the Treatment of Coronary Artery Disease. *New England Journal of Medicine*, 331, 496-501.

Fitzgibbon,G.M., Kafka,H.P., Leach,A.J., Keon,W.J., Hooper,G.D., and Burton,J.R. (1996). Coronary bypass graft fate and patient outcome: Angiographic follow-up of 5,065 grafts related to survival and reoperation in 1,388 patients during 25 years. *Journal of the American College of Cardiology*, 28, 616-626.

Forssmann,W.G., Meyer,M., and Forssmann,K. (2001). The renal urodilatin system: clinical implications. *Cardiovascular Research*, 51, 450-462.

Franco,V., Chen,Y.F., Oparil,S., Feng,J.A., Wang,D., Hage,F., and Perry,G. (2004). Atrial Natriuretic Peptide Dose-Dependently Inhibits Pressure Overload-Induced Cardiac Remodeling. *Hypertension*, 44, 746-750.

Frenette,P.S., Denis,C.V., Weiss,L., Jurk,K., Subbarao,S., Kehrel,B., Hartwig,J.H., Vestweber,D., and Wagner,D.D. (2000). P-Selectin Glycoprotein Ligand 1 (PSGL-1) Is Expressed on Platelets and Can Mediate Platelet-Endothelial Interactions In Vivo. *Journal of Experimental Medicine*, 191, 1413-1422.

Frostegord,J., Ulfgren,A.K., Nyberg,P., Hedin,U., Swedenborg,J., Andersson,U., and Hansson,G.K. (1999). Cytokine expression in advanced human atherosclerotic plaques: dominance of pro-inflammatory (Th1) and macrophage-stimulating cytokines. *Atherosclerosis*, 145, 33-43.

Fu,X.D., Cui,Y.H., Lin,G.P., and Wang,T.H. (2007). Non-genomic effects of 17beta-estradiol in activation of the ERK1/ERK2 pathway induces cell proliferation through upregulation of cyclin D1 expression in bovine artery endothelial cells. *Gynecological Endocrinology*, 23, 131-137.

Fuchs,A.T., Kuehnl,A., Pelisek,J., Rolland,P.H., Mekkaoui,C., Netz,H., and Nikol,S. (2008). Inhibition of restenosis formation without compromising reendothelialization as a potential solution to thrombosis following angioplasty? *Endothelium*, 15, 85-92.

Fukao,M., Mason,H.S., Britton,F.C., Kenyon,J.L., Horowitz,B., and Keef,K.D. (1999). Cyclic GMP-dependent Protein Kinase Activates Cloned BKCa Channels Expressed in Mammalian Cells by Direct Phosphorylation at Serine 1072. *Journal of Biological Chemistry*, 274, 10927-10935.

Fulton,D., Gratton,J.P., McCabe,T.J., Fontana,J., Fujio,Y., Walsh,K., Franke,T.F., Papapetropoulos,A., and Sessa,W.C. (1999). Regulation of endothelium-derived nitric oxide production by the protein kinase Akt. *Nature*, 399, 597-601.

Furchgott,R.F. and Zawadzki,J.V. (1980). The obligatory role of endothelial cells in the relaxation of arterial smooth muscle by acetylcholine. *Nature*, 288, 373-376.

Furukawa,K., Tawada,Y., and Shigekawa,M. (1988). Regulation of the plasma membrane Ca²⁺ pump by cyclic nucleotides in cultured vascular smooth muscle cells. *Journal of Biological Chemistry*, 263, 8058-8065.

Furukawa,Y., Matsumori,A., Ohashi,N., Shioi,T., Ono,K., Harada,A., Matsushima,K., and Sasayama,S. (1999). Anti-Monocyte Chemoattractant Protein-1/Monocyte Chemotactic and Activating Factor Antibody Inhibits Neointimal Hyperplasia in Injured Rat Carotid Arteries. *Circulation Research*, 84, 306-314.

Furuya,M., Aisaka,K., Miyazaki,T., Honbou,N., Kawashima,K., Ohno,T., Tanaka,S., Minamino,N., Kangawa,K., and Matsuo,H. (1993). C-Type Natriuretic Peptide Inhibits Intimal Thickening after Vascular Injury. *Biochemical and Biophysical Research Communications*, 193, 248-253.

Furuya,M., Yoshida,M., Hayashi,Y., Ohnuma,N., Minamino,N., Kangawa,K., and Matsuo,H. (1991). C-Type natriuretic peptide is a growth inhibitor of rat vascular

smooth muscle cells. *Biochemical and Biophysical Research Communications*, 177, 927-931.

Gaspari,T.A., Barber,M.N., Woods,R.L., and Dusting,G.J. (2000). Type-C natriuretic peptide prevents development of experimental atherosclerosis in rabbits. *Clinical and Experimental Pharmacology and Physiology*, 27, 653-655.

Gawaz,M., Langer,H., and May,A.E. (2005). Platelets in inflammation and atherogenesis. *Journal of Clinical Investigation*, 115, 3378-3384.

Gennaro,G., Menard,C., Michaud,S.E., Deblois,D., and Rivard,A. (2004). Inhibition of Vascular Smooth Muscle Cell Proliferation and Neointimal Formation in Injured Arteries by a Novel, Oral Mitogen-Activated Protein Kinase/Extracellular Signal-Regulated Kinase Inhibitor. *Circulation*, 110, 3367-3371.

Girard,F., Strausfeld,U., Fernandez,A., and Lamb,N.J.C. (1991). Cyclin a is required for the onset of DNA replication in mammalian fibroblasts. *Cell*, 67, 1169-1179.

Gliki,G., Wheeler-Jones,C., and Zachary,I. (2002). Vascular Endothelial Growth Factor induces Protein Kinase C (PKC)-dependent Akt/PKB activation and phosphatidylinositol 3'-kinase-mediated PKC[delta] phosphorylation: Role of PKC in angiogenesis. *Cell Biology International*, 26, 751-759.

Godecke,A., Decking,U.K.M., Ding,Z., Hirchenhain,J., Bidmon,H.J., Godecke,S., and Schrader,J. (1998). Coronary Hemodynamics in Endothelial NO Synthase Knockout Mice. *Circulation Research*, 82, 186-194.

Gorski,D.H., LePage,D.F., Patel,C.V., Copeland,N.G., Jenkins,N.A., and Walsh,K. (1993). Molecular cloning of a diverged homeobox gene that is rapidly down-regulated during the G0/G1 transition in vascular smooth muscle cells. *Molecular and Cellular Biology*, 13, 3722-3733.

Gorski,D.H. and Leal,A.J. (2003). Inhibition of endothelial cell activation by the homeobox gene Gax. *Journal of Surgical Research*, 111, 91-99.

Gower,W.R., Jr., Carter,G.M., McAfee,Q., and Solivan,S.M. (2006). Identification, regulation and anti-proliferative role of the NPR-C receptor in gastric epithelial cells. *Molecular and Cellular Biochemistry*, 293, 103-118.

Graf,K., Koehne,P., Grafe,M., Zhang,M., uch-Schwelk,W., and Fleck,E. (1995). Regulation and Differential Expression of Neutral Endopeptidase 24.11 in Human Endothelial Cells. *Hypertension*, 26, 230-235.

Gupta,K., Kshirsagar,S., Li,W., Gui,L., Ramakrishnan,S., Gupta,P., Law,P.Y., and Hebbel,R.P. (1999). VEGF Prevents Apoptosis of Human Microvascular Endothelial Cells via Opposing Effects on MAPK/ERK and SAPK/JNK Signaling. *Experimental Cell Research*, 247, 495-504.

Hama,N., Itoh,H., Shirakami,G., Suga,S., Komatsu,Y., Yoshimasa,T., Tanaka,I., Mori,K., and Nakao,K. (1994). Detection of C-Type Natriuretic Peptide in Human Circulation and Marked Increase of Plasma CNP Level in Septic Shock Patients. *Biochemical and Biophysical Research Communications*, 198, 1177-1182.

- Hartwell,D.W., Mayadas,T.N., Berger,G., Frenette,P.S., Rayburn,H., Hynes,R.O., and Wagner,D.D. (1998). Role of P-selectin cytoplasmic domain in granular targeting in vivo and in early inflammatory responses. *Journal of Cellular Biology*, 143, 1129-1141.
- Hashemolhosseini,S., Nagamine,Y., Morley,S.J., Desrivres,S., Mercep,L., and Ferrari,S. (1998). Rapamycin Inhibition of the G1 to S Transition Is Mediated by Effects on Cyclin D1 mRNA and Protein Stability. *Journal of Biological Chemistry*, 273, 14424-14429.
- Hassantash,S.A., Bikdeli,B., Kalantarian,S., Sadeghian,M., and Afshar,H. (2008). Pathophysiology of Aortocoronary Saphenous Vein Bypass Graft Disease. *Asian Cardiovascular Thoracic Annals*, 16, 331-336.
- He,M., Han,M., Zheng,B., Shu,Y.N., and Wen,J.K. (2009). Angiotensin II Stimulates KLF5 Phosphorylation and its Interaction with c-Jun Leading to Suppression of p21 Expression in Vascular Smooth Muscle Cells. *Journal of Biochemistry*, 146, 683-691.
- Herring,N., Zaman,J.A.B., and Paterson,D.J. (2001). Natriuretic peptides like NO facilitate cardiac vagal neurotransmission and bradycardia via a cGMP pathway. *American Journal of Physiology - Heart and Circulatory Physiology*, 281, H2318-H2327.
- Hobbs,A., Foster,P., Prescott,C., Scotland,R., and Ahluwalia,A. (2004). Natriuretic Peptide Receptor-C Regulates Coronary Blood Flow and Prevents Myocardial Ischemia/Reperfusion Injury: Novel Cardioprotective Role for Endothelium-Derived C-Type Natriuretic Peptide. *Circulation*, 110, 1231-1235.
- Hofmann,F., Ammendola,A., and Schlossmann,J. (2000). Rising behind NO: cGMP-dependent protein kinases. *Journal of Cell Science*, 113, 1671-1676.
- Horio,T., Tokudome,T., Maki,T., Yoshihara,F., Suga,S.i., Nishikimi,T., Kojima,M., Kawano,Y., and Kangawa,K. (2003). Gene Expression, Secretion, and Autocrine Action of C-Type Natriuretic Peptide in Cultured Adult Rat Cardiac Fibroblasts. *Endocrinology*, 144, 2279-2284.
- Hsiai,T.K., Cho,S.K., Wong,P.K., Ing,M.I.K.E., Salazar,A.D.L.E., Sevanian,A.L.E.X., Navab,M.O.H.A., Demer,L.L., and Ho,C.M. (2003). Monocyte recruitment to endothelial cells in response to oscillatory shear stress. *FASEB Journal*, 17, 1648-1657.
- Hsu,S.P., Ho,P.Y., Liang,Y.C., Ho,Y.S., and Lee,W.S. (2009). Involvement of the JNK activation in terbinafine-induced p21 up-regulation and DNA synthesis inhibition in human vascular endothelial cells. *Journal of Cellular Biochemistry*, 108, 860-866.
- Huang,A., Sun,D., Smith,C.J., Connetta,J.A., Shesely,E.G., Koller,A., and Kaley,G. (2000). In eNOS knockout mice skeletal muscle arteriolar dilation to acetylcholine is mediated by EDHF. *American Journal of Physiology - Heart and Circulatory Physiology*, 278, H762-H768.

- Huang,A., Wu,Y., Sun,D., Koller,A., and Kaley,G. (2001). Effect of estrogen on flow-induced dilation in NO deficiency: role of prostaglandins and EDHF. *Journal of Applied Physiology*, 91, 2561-2566.
- Hunt,P.J., Richards,A.M., Espiner,E.A., Nicholls,M.G., and Yandle,T.G. (1994). Bioactivity and metabolism of C-type natriuretic peptide in normal man. *Journal of Clinical Endocrinology and Metabolism*, 78, 1428-1435.
- Huo,Y., Schober,A., Forlow,S.B., Smith,D.F., Hyman,M.C., Jung,S., Littman,D.R., Weber,C., and Ley,K. (2003). Circulating activated platelets exacerbate atherosclerosis in mice deficient in apolipoprotein E. *Nature Medicine*, 9, 61-67.
- Hussain,M.B., MacAllister,R.J., and Hobbs,A.J. (2001). Reciprocal regulation of cGMP-mediated vasorelaxation by soluble and particulate guanylate cyclases. *American Journal of Physiology - Heart and Circulatory Physiology*, 280, H1151-H1159.
- Hutchinson,H.G., Trindade,P.T., Cunanan,D.B., Wu,C.F., and Pratt,R.E. (1997). Mechanisms of natriuretic-peptide-induced growth inhibition of vascular smooth muscle cells. *Cardiovascular Research*, 35, 158-167.
- Igaki,T., Itoh,H., Suga,S., Hama,N., Ogawa,Y., Komatsu,Y., Mukoyama,M., Sugawara,A., Yoshimasa,T., Tanaka,I., and Nakao,K. (1996). C-type natriuretic peptide in chronic renal failure and its action in humans. *Kidney International Supplement*, 55, S144-S147.
- Ignarro,L.J., Buga,G.M., Wood,K.S., Byrns,R.E., and Chaudhuri,G. (1987). Endothelium-derived relaxing factor produced and released from artery and vein is nitric oxide. *Proceedings of the National Academy of Sciences*, 84, 9265-9269.
- Ikeda,M., Kohno,M., Yasunari,K., Yokokawa,K., Horio,T., Ueda,M., Morisaki,N., and Yoshikawa,J. (1997). Natriuretic Peptide Family as a Novel Antimigration Factor of Vascular Smooth Muscle Cells. *Arteriosclerosis, Thrombosis and Vascular Biology*, 17, 731-736.
- Inoue,K., Naruse,K., Yamagami,S., Mitani,H., Suzuki,N., and Takei,Y. (2003). Four functionally distinct C-type natriuretic peptides found in fish reveal evolutionary history of the natriuretic peptide system. *Proceedings of the National Academy of Sciences*, 100, 10079-10084.
- Ishida,A., Sasaguri,T., Kosaka,C., Nojima,H., and Ogata,J. (1997). Induction of the Cyclin-dependent Kinase Inhibitor p21Sdi1/Cip1/Waf1 by Nitric Oxide-generating Vasodilator in Vascular Smooth Muscle Cells. *Journal of Biological Chemistry*, 272, 10050-10057.
- Ishida,A., Sasaguri,T., Miwa,Y., Kosaka,C., Taba,Y., and Abumiya,T. (1999). Tumor Suppressor p53 But Not cGMP Mediates NO-Induced Expression of p21Waf1/Cip1/Sdi1 in Vascular Smooth Muscle Cells. *Molecular Pharmacology*, 56, 938-946.
- Itoh,H., Pratt,R.E., Ohno,M., and Dzau,V.J. (1992). Atrial natriuretic polypeptide as a novel antigrowth factor of endothelial cells. *Hypertension*, 19, 758-761.

Johnson,R.C., Chapman,S.M., Dong,Z.M., Ordovas,J.M., Mayadas,T.N., Herz,J., Hynes,R.O., Schaefer,E.J., and Wagner,D.D. (1997). Absence of P-selectin delays fatty streak formation in mice. *Journal of Clinical Investigation*, 99, 1037-1043.

Kairuz,E.M., Barber,M.N., Anderson,C.R., Kanagasundaram,M., Drummond,G.R., and Woods,R.L. (2005). C-type natriuretic peptide (CNP) suppresses plasminogen activator inhibitor-1 (PAI-1) in vivo. *Cardiovascular Research*, 66, 574-582.

Take,T., Kitamura,H., Adachi,Y., Yoshioka,T., Watanabe,T., Matsushita,H., Fujii,T., Kondo,E., Tachibe,T., Kawase,Y., Jishage,K.i., Yasoda,A., Mukoyama,M., and Nakao,K. (2009). Chronically elevated plasma C-type natriuretic peptide level stimulates skeletal growth in transgenic mice. *American Journal of Physiology - Endocrinology and Metabolism*, 297, E1339-E1348.

Kalra,P.R., Clague,J.R., Bolger,A.P., Anker,S.D., Poole-Wilson,P.A., Struthers,A.D., and Coats,A.J. (2003). Myocardial Production of C-Type Natriuretic Peptide in Chronic Heart Failure. *Circulation*, 107, 571-573.

Kamata,K., Numazawa,T., and Kasuya,Y. (1996). Characteristics of vasodilatation induced by acetylcholine and platelet-activating factor in the rat mesenteric arterial bed. *European Journal of Pharmacology*, 298, 129-136.

Kanda,S., Miyata,Y., Mochizuki,Y., Matsuyama,T., and Kanetake,H. (2005). Angiopoietin 1 Is Mitogenic for Cultured Endothelial Cells. *Cancer Research*, 65, 6820-6827.

Karin,M. and Gallagher,E. (2005). From JNK to pay dirt: jun kinases, their biochemistry, physiology and clinical importance. *International Union of Biochemistry and Molecular Biology Life*, 57, 283-295.

Kawasaki,K., Smith,R.S., Jr., Hsieh,C.M., Sun,J., Chao,J., and Liao,J.K. (2003). Activation of the Phosphatidylinositol 3-Kinase/Protein Kinase Akt Pathway Mediates Nitric Oxide-Induced Endothelial Cell Migration and Angiogenesis. *Molecular and Cellular Biology*, 23, 5726-5737.

Kenny,A.J., Bourne,A., and Ingram,J. (1993). Hydrolysis of human and pig brain natriuretic peptides, urodilatin, C-type natriuretic peptide and some C-receptor ligands by endopeptidase-24.11. *Journal of Biochemistry*, 291, 83-88.

Khder,Y., Briancon,S., Petermann,R., Quilliot,D., Stoltz,J.F., Drouin,P., and Zannad,F. (1998). Shear stress abnormalities contribute to endothelial dysfunction in hypertension but not in type II diabetes. *Journal of Hypertension*, 16, 1619-1625.

Kibbe,M.R., Li,J., Nie,S., Watkins,S.C., Lizonova,A., Kovesdi,I., Simmons,R.L., Billiar,T.R., and Tzeng,E. (2000). Inducible nitric oxide synthase (iNOS) expression upregulates p21 and inhibits vascular smooth muscle cell proliferation through p42/44 mitogen-activated protein kinase activation and independent of p53 and cyclic guanosine monophosphate. *Journal of Vascular Surgery*, 31, 1214-1228.

Kim,Y.M., Namkoong,S., Yun,Y.G., Hong,H.D., Lee,Y.C., Ha,K.S., Lee,H., Kwon,H.J., Kwon,Y.G., and Kim,Y.M. (2007). Water extract of Korean red ginseng stimulates angiogenesis by activating the PI3K/Akt-dependent ERK1/2 and eNOS

pathways in human umbilical vein endothelial cells. *Biological and Pharmaceutical Bulletin*, 30, 1674-1679.

King III,S.B., Smith Jr,S.C., Hirshfeld Jr,J.W., Jacobs,A.K., Morrison,D.A., and Williams,D.O. (2008). 2007 Focused Update of the ACC/AHA/SCAI 2005 Guideline Update for Percutaneous Coronary Intervention. *Journal of the American College of Cardiology*, 51, 172-209.

Kintscher,U., Bruemmer,D., Blaschke,F., Unger,T., and Law,R.E. (2003). p38 MAP kinase negatively regulates angiotensin II-mediated effects on cell cycle molecules in human coronary smooth muscle cells. *Biochemical and Biophysical Research Communications*, 305, 552-556.

Kleinbongard,P., Schulz,R., Rassaf,T., Lauer,T., Dejam,A., Jax,T., Kumara,I., Gharini,P., Kabanova,S., Ozuyaman,B., Schnurch,H.G., Godecke,A., Weber,A.A., Robenek,M., Robenek,H., Bloch,W., Rosen,P., and Kelm,M. (2006). Red blood cells express a functional endothelial nitric oxide synthase. *Blood*, 107, 2943-2951.

Knowles,J.W., Reddick,R.L., Jennette,J.C., Shesely,E.G., Smithies,O., and Maeda,N. (2000). Enhanced atherosclerosis and kidney dysfunction in eNOS(-/-)Apoe(-/-) mice are ameliorated by enalapril treatment. *Journal of Clinical Investigation*, 105, 451-458.

Kohno,M., Yokokawa,K., Yasunari,K., Kano,H., Minami,M., Ueda,M., and Yoshikawa,J. (1997). Effect of Natriuretic Peptide Family on the Oxidized LDL-Induced Migration of Human Coronary Artery Smooth Muscle Cells. *Circulation Research*, 81, 585-590.

Koller,K.J. and Goeddel,D.V. (1992). Molecular biology of the natriuretic peptides and their receptors. *Circulation*, 86, 1081-1088.

Komalavilas,P. and Lincoln,T.M. (1996). Phosphorylation of the Inositol 1,4,5-Trisphosphate Receptor. *Journal of Biological Chemistry*, 271, 21933-21938.

Komatsu,Y., Chusho,H., Tamura,N., Yasoda,A., Miyazawa,T., Suda,M., Miura,M., Ogawa,Y., and Nakao,K. (2002). Significance of C-type natriuretic peptide (CNP) in endochondral ossification: analysis of CNP knockout mice. *Journal of Bone Mineralisation and Metabolism*, 20, 331-336.

Kone,B.C. (2001). Molecular biology of natriuretic peptides and nitric oxide synthases. *Cardiovascular Research*, 51, 429-441.

Kong,X., Wang,X., Xu,W., Behera,S., Hellermann,G., Kumar,A., Lockey,R.F., Mohapatra,S., and Mohapatra,S.S. (2008). Natriuretic Peptide Receptor A as a Novel Anticancer Target. *Cancer Research*, 68, 249-256.

Ku,D.N., Giddens,D.P., Zarins,C.K., and Glagov,S. (1985). Pulsatile flow and atherosclerosis in the human carotid bifurcation. Positive correlation between plaque location and low oscillating shear stress. *Arteriosclerosis, Thrombosis and Vascular Biology*, 5, 293-302.

Kuhlencordt,P.J., Rosel,E., Gerszten,R.E., Morales-Ruiz,M., Dombkowski,D., Atkinson,W.J., Han,F., Preffer,F., Rosenzweig,A., Sessa,W.C., Gimbrone,M.A., Jr., Ertl,G., and Huang,P.L. (2004). Role of endothelial nitric oxide synthase in endothelial activation: insights from eNOS knockout endothelial cells. *American Journal of Physiology - Cell Physiology*, 286, C1195-C1202.

Kuhnl,A., Pelisek,J., Tian,W., Kuhlmann,M., Rolland,P.H., Mekkaoui,C., Fuchs,A., and Nikol,S. (2005). C-type natriuretic peptide inhibits constrictive remodeling without compromising re-endothelialization in balloon-dilated renal arteries. *Journal of Endovascular Therapy*, 12, 171-182.

Kun,A., Kiraly,I., Pataricza,J., Marton,Z., Krassoi,I., Varro,A., Simonsen,U., Papp,J.G., and Pajor,L. (2008). C-Type Natriuretic Peptide Hyperpolarizes and Relaxes Human Penile Resistance Arteries. *Journal of Sexual Medicine*, 5, 1114-1125.

Kurihara,N., Alfie,M.E., Sigmon,D.H., Rhaleb,N.E., Shesely,E.G., and Carretero,O.A. (1998). Role of nNOS in Blood Pressure Regulation in eNOS Null Mutant Mice. *Hypertension*, 32, 856-861.

Lakka,T.A., Salonen,R., Kaplan,G.A., and Salonen,J.T. (1999). Blood Pressure and the Progression of Carotid Atherosclerosis in Middle-Aged Men. *Hypertension*, 34, 51-56.

Langenickel,T.H., Buttgereit,J., Pagel-Langenickel,I., Lindner,M., Monti,J., Beuerlein,K., Al-Saadi,N., Plehm,R., Popova,E., Tank,J., Dietz,R., Willenbrock,R., and Bader,M. (2006). Cardiac hypertrophy in transgenic rats expressing a dominant-negative mutant of the natriuretic peptide receptor B. *Proceedings of the National Academy of Sciences of the United States of America*, 103, 4735-4740.

Lee,B. and Moon,S.K. (2005). Ras/ERK signaling pathway mediates activation of the p21WAF1 gene promoter in vascular smooth muscle cells by platelet-derived growth factor. *Archives of Biochemistry and Biophysics*, 443, 113-119.

Lee,C.Y. and Burnett,J.C. (2007). Natriuretic peptides and therapeutic applications. *Heart Failure Reviews*, 12, 131-142.

Lee,S.J., Namkoong,S., Kim,Y.M., Kim,C.K., Lee,H., Ha,K.S., Chung,H.T., Kwon,Y.G., and Kim,Y.M. (2006). Fractalkine stimulates angiogenesis by activating the Raf-1/MEK/ERK- and PI3K/Akt/eNOS-dependent signal pathways. *American Journal of Physiology - Heart and Circulatory Physiology*, 291, H2836-H2846.

Leifeld,L., Fielenbach,M., Dumoulin,F.L., Speidel,N., Sauerbruch,T., and Spengler,U. (2002). Inducible nitric oxide synthase (iNOS) and endothelial nitric oxide synthase (eNOS) expression in fulminant hepatic failure. *Journal of Hepatology*, 37, 613-619.

Lerner,D.J. and Kannel,W.B. (1986). Patterns of coronary heart disease morbidity and mortality in the sexes: A 26-year follow-up of the Framingham population. *American Heart Journal*, 111, 383-390.

Lesnik,P., Haskell,C.A., and Charo,I.F. (2003). Decreased atherosclerosis in CX3CR1^{-/-} mice reveals a role for fractalkine in atherogenesis. *Journal of Clinical Investigation*, 111, 333-340.

- Levin,E.R. and Frank,H.J. (1991). Natriuretic peptides inhibit rat astroglial proliferation: mediation by C receptor. *American Journal of Physiology - Regulatory, Integrative and Comparative Physiology*, 261, R453-R457.
- Levin,E.R., Gardner,D.G., and Samson,W.K. (1998). Natriuretic Peptides. *New England Journal of Medicine*, 339, 321-328.
- Lewington,S., Clarke,R., Qizilbash,N., Peto,R., and Collins,R. (2002). Age-specific relevance of usual blood pressure to vascular mortality: a meta-analysis of individual data for one million adults in 61 prospective studies. *Lancet*, 360, 1903-1913.
- Liang,Y., Fang,M., Li,J., and Yew,D.T. (2006). Immunohistochemical localization of endothelial isoform (eNOS) in human cerebral arteries and the aorta. *International Journal of Neuroscience*, 116, 1403-1417.
- Liapis,C.D., Avgerinos,E.D., Kadoglou,N.P., and Kakisis,J.D. (2009). What a vascular surgeon should know and do about atherosclerotic risk factors. *Journal of Vascular Surgery*, 49, 1348-1354.
- Libby,P. (2002). Inflammation in atherosclerosis. *Nature*, 420, 868-874.
- Lisy,O., Jougasaki,M., Heublein,D.M., Schirger,J.A., Chen,H.H., Wennberg,P.W., and Burnett,J.C. (1999). Renal actions of synthetic dendroaspis natriuretic peptide. *Kidney International*, 56, 502-508.
- Liu,M.Y., Hattori,Y., Sato,A., Ichikawa,R., Zhang,X.H., and Sakuma,I. (2002). Ovariectomy attenuates hyperpolarization and relaxation mediated by endothelium-derived hyperpolarizing factor in female rat mesenteric artery: a concomitant decrease in connexin-43 expression. *Journal of Cardiovascular Pharmacology*, 40, 938-948.
- Lowe,D.G., Chang,M.S., Hellmiss,R., Chen,E., Singh,S., Garbers,D.L., and Goeddel,D.V. (1989). Human atrial natriuretic peptide receptor defines a new paradigm for second messenger signal transduction. *European Molecular Biology Organization Journal*, 8, 1377-1384.
- Lowenstein,C.J. and Cameron,S.J. (2010). High-density lipoprotein metabolism and endothelial function. *Current Opinion in Endocrinology, Diabetes and Obesity*, 17, 166-170.
- Lu,Q., Qiu,T.Q., and Yang,H. (2006). Ligustilide inhibits vascular smooth muscle cells proliferation. *European Journal of Pharmacology*, 542, 136-140.
- Luksha,L., Agewall,S., and Kublickiene,K. (2009). Endothelium-derived hyperpolarizing factor in vascular physiology and cardiovascular disease. *Atherosclerosis*, 202, 330-344.
- Maack,T. (1992). Receptors of atrial natriuretic factor. *Annual Review of Physiology*, 54, 11-27.
- Maack,T., Suzuki,M., Almeida,F.A., Nussenzveig,D., Scarborough,R.M., McEnroe,G.A., and Lewicki,J.A. (1987). Physiological role of silent receptors of atrial natriuretic factor. *Science*, 238, 675-678.

Madhani,M., Okorie,M., Hobbs,A.J., and MacAllister,R.J. (2006). Reciprocal regulation of human soluble and particulate guanylate cyclases in vivo. *British Journal of Pharmacology*, 149, 797-801.

Madhani,M., Scotland,R.S., MacAllister,R.J., and Hobbs,A.J. (2003). Vascular natriuretic peptide receptor-linked particulate guanylate cyclases are modulated by nitric oxide-cyclic GMP signalling. *British Journal of Pharmacology*, 139, 1289-1296.

Maillard,L., Van,B.E., Tio,F.O., Rivard,A., Kearney,M., Branellec,D., Steg,P.G., Isner,J.M., and Walsh,K. (2000). Effect of percutaneous adenovirus-mediated Gax gene delivery to the arterial wall in double-injured atheromatous stented rabbit iliac arteries. *Gene Therapy*, 7, 1353-1361.

Marra,D.E., Simoncini,T., and Liao,J.K. (2000). Inhibition of Vascular Smooth Muscle Cell Proliferation by Sodium Salicylate Mediated by Upregulation of p21Waf1 and p27Kip1. *Circulation*, 102, 2124-2130.

Massberg,S., Brand,K., Gruner,S., Page,S., Muller,E., Muller,I., Bergmeier,W., Richter,T., Lorenz,M., Konrad,I., Nieswandt,B., and Gawaz,M. (2002). A Critical Role of Platelet Adhesion in the Initiation of Atherosclerotic Lesion Formation. *Journal of Experimental Medicine*, 196, 887-896.

Massberg,S., Schurzinger,K., Lorenz,M., Konrad,I., Schulz,C., Plesnila,N., Kennerknecht,E., Rudelius,M., Sauer,S., Braun,S., Kremmer,E., Emambokus,N.R., Frampton,J., and Gawaz,M. (2005). Platelet Adhesion Via Glycoprotein IIb Integrin Is Critical for Atheroprogession and Focal Cerebral Ischemia: An In Vivo Study in Mice Lacking Glycoprotein IIb. *Circulation*, 112, 1180-1188.

Matsukawa,N., Grzesik,W.J., Takahashi,N., Pandey,K.N., Pang,S., Yamauchi,M., and Smithies,O. (1999). The natriuretic peptide clearance receptor locally modulates the physiological effects of the natriuretic peptide system. *Proceedings of the National Academy of Sciences*, 96, 7403-7408.

Matter,C.M., Rozenberg,I., Jaschko,A., Greutert,H., Kurz,D.J., Wnendt,S., Kuttler,B., Joch,H., Grunenfelder,J., Zund,G., Tanner,F.C., and Luscher,T.F. (2006). Effects of tacrolimus or sirolimus on proliferation of vascular smooth muscle and endothelial cells. *Journal of Cardiovascular Pharmacology*, 48, 286-292.

May,A.E., Seizer,P., and Gawaz,M. (2008). Platelets: Inflammatory Firebugs of Vascular Walls. *Arteriosclerosis, Thrombosis and Vascular Biology*, 28, s5-10.

McCulloch,A.I. and Randall,M.D. (1998). Sex differences in the relative contributions of nitric oxide and EDHF to agonist-stimulated endothelium-dependent relaxations in the rat isolated mesenteric arterial bed. *British Journal of Pharmacology*, 123, 1700-1706.

McGill,H.C., Jr., McMahan,C.A., Malcom,G.T., Oalman,M.C., and Strong,J.P. (1997). Effects of Serum Lipoproteins and Smoking on Atherosclerosis in Young Men and Women. *Arteriosclerosis, Thrombosis and Vascular Biology*, 17, 95-106.

Meloche,S. and Pouyssegur,J. (2007). The ERK1//2 mitogen-activated protein kinase pathway as a master regulator of the G1- to S-phase transition. *Oncogene*, 26, 3227-3239.

Mendelsohn,M.E. and Karas,R.H. (2005). Molecular and Cellular Basis of Cardiovascular Gender Differences. *Science*, 308, 1583-1587.

Miao,L., Dai,Y., and Zhang,J. (2002). Mechanism of RhoA/Rho kinase activation in endothelin-1- induced contraction in rabbit basilar artery. *American Journal of Physiology - Heart and Circulatory Physiology*, 283, H983-H989.

Min,J.K., Han,K.Y., Kim,E.C., Kim,Y.M., Lee,S.W., Kim,O.H., Kim,K.W., Gho,Y.S., and Kwon,Y.G. (2004). Capsaicin Inhibits in Vitro and in Vivo Angiogenesis. *Cancer Research*, 64, 644-651.

Minamino,N., Makino,Y., Tateyama,H., Kangawa,K., and Matsuo,H. (1991). Characterization of immunoreactive human C-type natriuretic peptide in brain and heart. *Biochemical and Biophysical Research Communications*, 179, 535-542.

Moncada,S. and Higgs,A. (1993). The L-Arginine-Nitric Oxide Pathway. *New England Journal of Medicine*, 329, 2002-2012.

Moreno,R.I., Fernandez,C., Hernandez,R., Alfonso,F., Angiolillo,D.J., Sabate,M., Escaned,J., Banuelos,C., Fernandez-Ortiz,A., and Macaya,C. (2005). Drug-eluting stent thrombosis: Results from a pooled analysis including 10 randomized studies. *Journal of the American College of Cardiology*, 45, 954-959.

Mori,T., Chen,Y.F., Feng,J.A., Hayashi,T., Oparil,S., and Perry,G.J. (2004). Volume overload results in exaggerated cardiac hypertrophy in the atrial natriuretic peptide knockout mouse. *Cardiovascular Research*, 61, 771-779.

Morice,M.C., Serruys,P.W., Barragan,P., Bode,C., Van Es,G.A., Stoll,H.P., Snead,D., Mauri,L., Cutlip,D.E., and Sousa,E. (2007). Long-Term Clinical Outcomes With Sirolimus-Eluting Coronary Stents: Five-Year Results of the RAVEL Trial. *Journal of the American College of Cardiology*, 50, 1299-1304.

Morishige,K., Shimokawa,H., Yamawaki,T., Miyata,K., Eto,Y., Kandabashi,T., Yogo,K., Higo,T., Egashira,K., Ueno,H., and Takeshita,A. (2000). Local adenovirus-mediated transfer of C-type natriuretic peptide suppresses vascular remodeling in porcine coronary arteries in vivo. *Journal of the American College of Cardiology*, 35, 1040-1047.

Motwani,J.G. and Topol,E.J. (1998). Aortocoronary Saphenous Vein Graft Disease : Pathogenesis, Predisposition, and Prevention. *Circulation*, 97, 916-931.

Mukoyama,M., Nakao,K., Hosoda,K., Suga,S., Saito,Y., Ogawa,Y., Shirakami,G., Jougasaki,M., Obata,K., Yasue,H., and . (1991). Brain natriuretic peptide as a novel cardiac hormone in humans. Evidence for an exquisite dual natriuretic peptide system, atrial natriuretic peptide and brain natriuretic peptide. *Journal of Clinical Investigation*, 87, 1402-1412.

Munro,E., Patel,M., Chan,P., Betteridge,L., Clunn,G., Gallagher,K., Hughes,A., Schachter,M., Wolfe,J., and Sever,P. (1994). Inhibition of human vascular smooth muscle cell proliferation by lovastatin: the role of isoprenoid intermediates of cholesterol synthesis. *European Journal of Clinical Investigation*, 24, 766-772.

Murthy,K.S., Teng,B.Q., Jin,J.G., and Makhlof,G.M. (1998). G protein-dependent activation of smooth muscle eNOS via natriuretic peptide clearance receptor. *American Journal of Physiology - Cell Physiology*, 275, C1409-C1416.

Murthy,K.S., Teng,B.Q., Zhou,H., Jin,J.G., Grider,J.R., and Makhlof,G.M. (2000). Gi-1/Gi-2-dependent signaling by single-transmembrane natriuretic peptide clearance receptor. *American Journal of Physiology - Gastrointestinal and Liver Physiology*, 278, G974-G980.

Nabel,E.G. (1991). Biology of the impaired endothelium. *The American Journal of Cardiology*, 68, 6-8.

Nageh,M.F., Sandberg,E.T., Marotti,K.R., Lin,A.H., Melchior,E.P., Bullard,D.C., and Beaudet,A.L. (1997). Deficiency of Inflammatory Cell Adhesion Molecules Protects Against Atherosclerosis in Mice. *Arteriosclerosis, Thrombosis and Vascular Biology*, 17, 1517-1520.

Nakagami,H., Morishita,R., Yamamoto,K., Taniyama,Y., Aoki,M., Matsumoto,K., Nakamura,T., Kaneda,Y., Horiuchi,M., and Ogihara,T. (2001). Mitogenic and Antiapoptotic Actions of Hepatocyte Growth Factor Through ERK, STAT3, and Akt in Endothelial Cells. *Hypertension*, 37, 581-586.

Naruko,T., Itoh,A., Haze,K., Ehara,S., Fukushima,H., Sugama,Y., Shirai,N., Ikura,Y., Ohsawa,M., and Ueda,M. (2005). C-Type natriuretic peptide and natriuretic peptide receptors are expressed by smooth muscle cells in the neointima after percutaneous coronary intervention. *Atherosclerosis*, 181, 241-250.

Naruko,T., Ueda,M., van der Wal,A.C., van der Loos,C.M., Itoh,H., Nakao,K., and Becker,A.E. (1996). C-Type Natriuretic Peptide in Human Coronary Atherosclerotic Lesions. *Circulation*, 94, 3103-3108.

Nazario,B., Hu,R.M., Pedram,A., Prins,B., and Levin,E.R. (1995). Atrial and brain natriuretic peptides stimulate the production and secretion of C-type natriuretic peptide from bovine aortic endothelial cells. *Journal of Clinical Investigation*, 95, 1151-1157.

New,D.C. and Wong,Y.H. (2007). Molecular mechanisms mediating the G protein-coupled receptor regulation of cell cycle progression. *Journal of Molecular Signalling*, 2, 2.

Neylon,C.B. (1999). Vascular biology of endothelin signal transduction. *Clinical and Experimental Pharmacology and Physiology*, 26, 149-153.

Nishikawa,Y., Stepp,D.W., and Chilian,W.M. (2000). Nitric oxide exerts feedback inhibition on EDHF-induced coronary arteriolar dilation in vivo. *American Journal of Physiology - Heart and Circulatory Physiology*, 279, H459-H465.

Oda,H., Kasiske,B.L., O'Donnell,M.P., and Keane,W.F. (1999). Effects of lovastatin on expression of cell cycle regulatory proteins in vascular smooth muscle cells. *Kidney International Supplement*, 71, S202-S205.

Ogawa,Y., Nakao,K., Nakagawa,O., Komatsu,Y., Hosoda,K., Suga,S., Arai,H., Nagata,K., Yoshida,N., and Imura,H. (1992). Human C-type natriuretic peptide. Characterization of the gene and peptide. *Hypertension*, 19, 809-813.

Ogawa,Y., Itoh,H., Yoshitake,Y., Inoue,M., Yoshimasa,T., Serikawa,T., and Nakao,K. (1994). Molecular Cloning and Chromosomal Assignment of the Mouse C-Type Natriuretic Peptide (CNP) Gene (Nppc): Comparison with the Human CNP Gene (NPPC). *Genomics*, 24, 383-387.

Ohno,N., Itoh,H., Ikeda,T., Ueyama,K., Yamahara,K., Doi,K., Yamashita,J., Inoue,M., Masatsugu,K., Sawada,N., Fukunaga,Y., Sakaguchi,S., Sone,M., Yurugi,T., Kook,H., Komeda,M., and Nakao,K. (2002). Accelerated Reendothelialization With Suppressed Thrombogenic Property and Neointimal Hyperplasia of Rabbit Jugular Vein Grafts by Adenovirus-Mediated Gene Transfer of C-Type Natriuretic Peptide. *Circulation*, 105, 1623-1626.

Ohtsubo,M., Theodoras,A.M., Schumacher,J., Roberts,J.M., and Pagano,M. (1995). Human cyclin E, a nuclear protein essential for the G1-to-S phase transition. *Molecular and Cellular Biology*, 15, 2612-2624.

Okolicany,J., McEnroe,G.A., Koh,G.Y., Lewicki,J.A., and Maack,T. (1992). Clearance receptor and neutral endopeptidase-mediated metabolism of atrial natriuretic factor. *American Journal of Physiology*, 263, F546-F553.

Olins,G.M., Krieter,P.A., Trapani,A.J., Spear,K.L., and Bovy,P.R. (1989). Specific inhibitors of endopeptidase 24.11 inhibit the metabolism of atrial natriuretic peptides in vitro and in vivo. *Molecular and Cellular Endocrinology*, 61, 201-208.

Oliver,P.M., Fox,J.E., Kim,R., Rockman,H.A., Kim,H.S., Reddick,R.L., Pandey,K.N., Milgram,S.L., Smithies,O., and Maeda,N. (1997). Hypertension, cardiac hypertrophy, and sudden death in mice lacking natriuretic peptide receptor A. *Proceedings of the National Academy of Sciences*, 94, 14730-14735.

Ollinger,R., Thomas,M., Kogler,P., Hermann,M., Weiss,H., Mark,W., Bilban,M., Troppmair,J., Bach,F.H., and Margreiter,R. (2008). Blockade of p38 MAPK Inhibits Chronic Allograft Vasculopathy. *Transplantation*, 85, 293-297.

Ortiz,P.A. and Garvin,J.L. (2003). Cardiovascular and renal control in NOS-deficient mouse models. *American Journal of Physiology - Regulatory, Integrative and Comparative Physiology*, 284, R628-R638.

Osawa,H., Yamabe,H., Kaizuka,M., Tamura,N., Tsunoda,S., Baba,Y., Shirato,K., Tateyama,F., and Okumura,K. (2000). C-Type natriuretic peptide inhibits proliferation and monocyte chemoattractant protein-1 secretion in cultured human mesangial cells. *Nephron*, 86, 467-472.

Padro,T., Emeis,J.J., Steins,M., Schmid,K.W., and Kienast,J. (1995). Quantification of Plasminogen Activators and Their Inhibitors in the Aortic Vessel Wall in Relation to

the Presence and Severity of Atherosclerotic Disease. *Arteriosclerosis, Thrombosis and Vascular Biology*, 15, 893-902.

Pagano,M. and Anand-Srivastava,M.B. (2001). Cytoplasmic Domain of Natriuretic Peptide Receptor C Constitutes Gi Activator Sequences That Inhibit Adenylyl Cyclase Activity. *Journal of Biological Chemistry*, 276, 22064-22070.

Pak,K.J., Geary,G.G., Duckles,S.P., and Krause,D.N. (2002). Male-female differences in the relative contribution of endothelial vasodilators released by rat tail artery. *Life Sciences*, 71, 1633-1642.

Palmer,R.M., Ferrige,A.G., and Moncada,S. (1987). Nitric oxide release accounts for the biological activity of endothelium-derived relaxing factor. *Nature*, 327, 524-526.

Panayiotou,C.M. (2007). Characterisation of the anti-inflammatory and anti-proliferative effects of natriuretic peptides in rodents. PhD thesis. University College London.

Papapetropoulos,A., Garcia-Cardena,G., Madri,J.A., and Sessa,W.C. (1997). Nitric oxide production contributes to the angiogenic properties of vascular endothelial growth factor in human endothelial cells. *Journal of Clinical Investigation*, 100, 3131-3139.

Papapetropoulos,A., Pyriochou,A., Altaany,Z., Yang,G., Marazioti,A., Zhou,Z., Jeschke,M.G., Branski,L.K., Herndon,D.N., Wang,R., and Szab,C. (2009). Hydrogen sulfide is an endogenous stimulator of angiogenesis. *Proceedings of the National Academy of Sciences*, 106, 21972-21977.

Parry,T.J., Brosius,R., Thyagarajan,R., Carter,D., Argentieri,D., Falotico,R., and Siekierka,J. (2005). Drug-eluting stents: Sirolimus and paclitaxel differentially affect cultured cells and injured arteries. *European Journal of Pharmacology*, 524, 19-29.

Pearson,G., Robinson,F., Beers Gibson,T., Xu,B., Karandikar,M., Berman,K., and Cobb,M.H. (2001). Mitogen-Activated Protein (MAP) Kinase Pathways: Regulation and Physiological Functions. *Endocrine Reviews*, 22, 153-183.

Pedram,A., Razandi,M., and Levin,E.R. (1998). Extracellular Signal-regulated Protein Kinase/Jun Kinase Cross-talk Underlies Vascular Endothelial Cell Growth Factor-induced Endothelial Cell Proliferation. *Journal of Biological Chemistry*, 273, 26722-26728.

Pelisek,J., Fuchs,A.T., Kuehnl,A., Tian,W., Kuhlmann,M.T., Rolland,P.H., Mekkaoui,C., Gaedtke,L., and Nikol,S. (2006). C-type natriuretic peptide for reduction of restenosis: gene transfer is superior over single peptide administration. *Journal of Gene Medicine*, 8, 835-844.

Peltonen,T.O., Taskinen,P., Soini,Y., Rysa,J., Ronkainen,J., Ohtonen,P., Satta,J., Juvonen,T., Ruskoaho,H., and Leskinen,H. (2007). Distinct Downregulation of C-Type Natriuretic Peptide System in Human Aortic Valve Stenosis. *Circulation*, 116, 1283-1289.

Pfisterer,M., Brunner-La Rocca,H.P., Buser,P.T., Rickenbacher,P., Hunziker,P., Mueller,C., Jeger,R., Bader,F., Osswald,S., and Kaiser,C. (2006). Late Clinical Events After Clopidogrel Discontinuation May Limit the Benefit of Drug-Eluting Stents: An Observational Study of Drug-Eluting Versus Bare-Metal Stents. *Journal of the American College of Cardiology*, 48, 2584-2591.

Pollock,J.S., Forstermann,U., Mitchell,J.A., Warner,T.D., Schmidt,H.H., Nakane,M., and Murad,F. (1991). Purification and characterization of particulate endothelium-derived relaxing factor synthase from cultured and native bovine aortic endothelial cells. *Proceedings of the National Academy of Sciences*, 88, 10480-10484.

Potter,L.R., bbey-Hosch,S., and Dickey,D.M. (2006). Natriuretic Peptides, Their Receptors, and Cyclic Guanosine Monophosphate-Dependent Signaling Functions. *Endocrine Reviews*, 27, 47-72.

Prickett,T.C.R., Barrell,G.K., Wellby,M., Yandle,T.G., Richards,A.M., and Espiner,E.A. (2008). Effect of sex steroids on plasma C-type natriuretic peptide forms: stimulation by oestradiol in lambs and adult sheep. *Journal of Endocrinology*, 199, 481-487.

Proctor,B.M., Jin,X., Lupu,T.S., Muglia,L.J., Semenkovich,C.F., and Muslin,A.J. (2008). Requirement for p38 Mitogen-Activated Protein Kinase Activity in Neointima Formation After Vascular Injury. *Circulation*, 118, 658-666.

Qian,J.Y., Haruno,A., Asada,Y., Nishida,T., Saito,Y., Matsuda,T., and Ueno,H. (2002). Local Expression of C-Type Natriuretic Peptide Suppresses Inflammation, Eliminates Shear Stress-Induced Thrombosis, and Prevents Neointima Formation Through Enhanced Nitric Oxide Production in Rabbit Injured Carotid Arteries. *Circulation Research*, 91, 1063-1069.

Raines,E.W. and Ross,R. (1993). Smooth muscle cells and the pathogenesis of the lesions of atherosclerosis. *British Heart Journal*, 69, S30-S37.

Rautureau,Y., Gowers,I., Wheeler-Jones,C.P., and Baxter,G.F. (2010). C-type natriuretic peptide regulation of guanosine-3',5'-cyclic monophosphate production in human endothelial cells. *Autonomic and Autocoid Pharmacology*, 30, 185-192.

Rikitake,Y., Kawashima,S., Yamashita,T., Ueyama,T., Ishido,S., Hotta,H., Hirata,K.i., and Yokoyama,M. (2000). Lysophosphatidylcholine Inhibits Endothelial Cell Migration and Proliferation via Inhibition of the Extracellular Signal-Regulated Kinase Pathway. *Arteriosclerosis, Thrombosis and Vascular Biology*, 20, 1006-1012.

Romo,G.M., Dong,J.F., Schade,A.J., Gardiner,E.E., Kansas,G.S., Li,C.Q., McIntire,L.V., Berndt,M.C., and Lopez,J.A. (1999). The Glycoprotein Ib-IX-V Complex Is a Platelet Counterreceptor for P-Selectin. *Journal of Experimental Medicine*, 190, 803-814.

Rose,R.A., Lomax,A.E., Kondo,C.S., nand-Srivastava,M.B., and Giles,W.R. (2004). Effects of C-type natriuretic peptide on ionic currents in mouse sinoatrial node: a role for the NPR-C receptor. *American Journal of Physiology - Heart and Circulatory Physiology*, 286, H1970-H1977.

Ross,R. (1999). Atherosclerosis -- An Inflammatory Disease. *New England Journal of Medicine*, 340, 115-126.

Rousseau,S., Houle,F., Landry,J., and Huot,J. (1997). p38 MAP kinase activation by vascular endothelial growth factor mediates actin reorganization and cell migration in human endothelial cells. *Oncogene*, 15, 2169-2177.

Sabrane,K., Kruse,M.N., Fabritz,L., Zetsche,B., Mitko,D., Skryabin,B.V., Zwiener,M., Baba,H.A., Yanagisawa,M., and Kuhn,M. (2005). Vascular endothelium is critically involved in the hypotensive and hypovolemic actions of atrial natriuretic peptide. *Journal of Clinical Investigation*, 115, 1666-1674.

Samson,W.K., Aguila,M.C., Martinovic,J., ntunes-Rodrigues,J., and Norris,M. (1987). Hypothalamic action of atrial natriuretic factor to inhibit vasopressin secretion. *Peptides*, 8, 449-454.

Sato,J., Nair,K., Hiddinga,J., Eberhardt,N.L., Fitzpatrick,L.A., Katusic,Z.S., and O'Brien,T. (2000). eNOS gene transfer to vascular smooth muscle cells inhibits cell proliferation via upregulation of p27 and p21 and not apoptosis. *Cardiovascular Research*, 47, 697-706.

Sauer,B. and Henderson,N. (1988). Site-specific DNA recombination in mammalian cells by the Cre recombinase of bacteriophage P1. *Proceedings of the National Academy of Sciences of the United States of America*, 85, 5166-5170.

Sauer,B. (1998). Inducible Gene Targeting in Mice Using the Cre/loxSystem. *Methods*, 14, 381-392.

Savage,M.P., Fischman,D.L., Rake,R., Leon,M.B., Schatz,R.A., Penn,I., Nobuyoshi,M., Moses,J., Hirshfeld,J., Heuser,R., Baim,D., Cleman,M., Brinker,J., Gebhardt,S., and Goldberg,S. (1998). Efficacy of coronary stenting versus balloon angioplasty in small coronary arteries. Stent Restenosis Study (STRESS) Investigators. *Journal of the American College of Cardiology*, 31, 307-311.

Schachner,T., Zou,Y., Oberhuber,A., Mairinger,T., Tzankov,A., Laufer,G., Ott,H., and Bonatti,J. (2004). Perivascular application of C-type natriuretic peptide attenuates neointimal hyperplasia in experimental vein grafts. *European Journal of Cardio-Thoracic Surgery*, 25, 585-590.

Schirger,J.A., Heublein,D.M., Chen,H.H., Lisy,O., Jougasaki,M., Wennberg,P.W., and Burnett,J.C. (1999). Presence of Dendroaspis natriuretic peptide-like immunoreactivity in human plasma and its increase during human heart failure. *Mayo Clinic Proceedings*, 74, 126-130.

Schlaeger,T.M., Bartunkova,S., Lawitts,J.A., Teichmann,G., Risau,W., Deutsch,U., and Sato,T.N. (1997). Uniform vascular-endothelial-cell-specific gene expression in both embryonic and adult transgenic mice. *Proceedings of the National Academy of Sciences*, 94, 3058-3063.

Schulz-Knappe,P., Forssmann,K., Herbst,F., Hock,D., Pipkorn,R., and Forssmann,W.G. (1988). Isolation and structural analysis of "urodilatin", a new

peptide of the cardiodilatin-(ANP)-family, extracted from human urine. *Weiner Klinische Wochenschrift*, 66, 752-759.

Schweitz,H., Vigne,P., Moinier,D., Frelin,C., and Lazdunski,M. (1992). A new member of the natriuretic peptide family is present in the venom of the green mamba (*Dendroaspis angusticeps*). *Journal of Biological Chemistry*, 267, 13928-13932.

Schwartz,D.W.P. and Vaitkus,P.M. (2003). Drug-Eluting Stents To Prevent Reblockage of Coronary Arteries. *Journal of Cardiovascular Nursing*, 18, 11-16.

Scotland,R.S., Ahluwalia,A., and Hobbs,A.J. (2005a). C-type natriuretic peptide in vascular physiology and disease. *Pharmacology & Therapeutics*, 105, 85-93.

Scotland,R.S., Chauhan,S., Vallance,P.J.T., and Ahluwalia,A. (2001). An Endothelium-Derived Hyperpolarizing Factor-Like Factor Moderates Myogenic Constriction of Mesenteric Resistance Arteries in the Absence of Endothelial Nitric Oxide Synthase-Derived Nitric Oxide. *Hypertension*, 38, 833-839.

Scotland,R.S., Cohen,M., Foster,P., Lovell,M., Mathur,A., Ahluwalia,A., and Hobbs,A.J. (2005b). C-type natriuretic peptide inhibits leukocyte recruitment and platelet-leukocyte interactions via suppression of P-selectin expression. *Proceedings of the National Academy of Sciences*, 102, 14452-14457.

Scotland,R.S., Madhani,M., Chauhan,S., Moncada,S., Andresen,J., Nilsson,H., Hobbs,A.J., and Ahluwalia,A. (2005c). Investigation of Vascular Responses in Endothelial Nitric Oxide Synthase/Cyclooxygenase-1 Double-Knockout Mice: Key Role for Endothelium-Derived Hyperpolarizing Factor in the Regulation of Blood Pressure in Vivo. *Circulation*, 111, 796-803.

Serrano,M.D., Ramires,M.F.J.A., Venturinelli,B.S., Arie,M.D., D'Amico,M.D., Zweier,M.D., Pileggi,M.D., and da Luz,M.F.P. (1997). Coronary Angioplasty Results in Leukocyte and Platelet Activation With Adhesion Molecule Expression: Evidence of Inflammatory Responses in Coronary Angioplasty. *Journal of the American College of Cardiology*, 29, 1276-1283.

Serruys,P.W., de Jaegere,P., Kiemeneij,F., Macaya,C., Rutsch,W., Heyndrickx,G., Emanuelsson,H., Marco,J., Legrand,V., Materne,P., Belardi,J., Sigwart,U., Colombo,A., Goy,J.J., van den Heuvel,P., Delcan,J., Morel,M.a., and The Benestent Study Group (1994). A Comparison of Balloon-Expandable-Stent Implantation with Balloon Angioplasty in Patients with Coronary Artery Disease. *New England Journal of Medicine*, 331, 489-495.

Seymour,A.A., Mathers,P.D., bboa-Offei,B.E., Asaad,M.M., and Weber,H. (1996). Renal and Depressor Activity of C-Natriuretic Peptide in Conscious Monkeys: Effects of Enzyme Inhibitors. *Journal of Cardiovascular Pharmacology*, 28, 397-401.

Shesely,E., Maeda,N., Kim,H.S., Desai,K., Krege,J., Laubach,V., Sherman,P., Sessa,W., and Smithies,O. (1996). Elevated blood pressures in mice lacking endothelial nitric oxide synthase. *Proceedings of the National Academy of Sciences of the United States of America*, 93, 13176-13181.

- Shimokawa,H., Yasutake,H., Fujii,K., Owada,M.K., Nakaike,R., Fukumoto,Y., Takayanagi,T., Nagao,T., Egashira,K., Fujishima,M., and Takeshita,A. (1996). The importance of the hyperpolarizing mechanism increases as the vessel size decreases in endothelium-dependent relaxations in rat mesenteric circulation. *Journal of Cardiovascular Pharmacology*, 28, 703-711.
- Shiojima,I. and Walsh,K. (2002). Role of Akt Signaling in Vascular Homeostasis and Angiogenesis. *Circulation Research*, 90, 1243-1250.
- Simons,M. (2004). Integrative signaling in angiogenesis. *Molecular and Cellular Biochemistry*, 264, 99-102.
- Simons,M. (2005). Angiogenesis: Where Do We Stand Now? *Circulation*, 111, 1556-1566.
- Sipahi,I., Tuzcu,E.M., Schoenhagen,P., Wolski,K.E., Nicholls,S.J., Balog,C., Crowe,T.D., and Nissen,S.E. (2006). Effects of Normal, Pre-Hypertensive, and Hypertensive Blood Pressure Levels on Progression of Coronary Atherosclerosis. *Journal of the American College of Cardiology*, 48, 833-838.
- Skalen,K., Gustafsson,M., Rydberg,E.K., Hulten,L.M., Wiklund,O., Innerarity,T.L., and Boren,J. (2002). Subendothelial retention of atherogenic lipoproteins in early atherosclerosis. *Nature*, 417, 750-754.
- Smith,R.C., Branellec,D., Gorski,D.H., Guo,K., Perlman,H., Dedieu,J.F., Pastore,C., Mahfoudi,A., Deneffe,P., Isner,J.M., and Walsh,K. (1997). p21CIP1-mediated inhibition of cell proliferation by overexpression of the *gax* homeodomain gene. *Genes and Development*, 11, 1674-1689.
- Soeki,T., Kishimoto,I., Okumura,H., Tokudome,T., Horio,T., Mori,K., and Kangawa,K. (2005). C-type natriuretic peptide, a novel antifibrotic and antihypertrophic agent, prevents cardiac remodeling after myocardial infarction. *Journal of the American College of Cardiology*, 45, 608-616.
- Solberg,L.A. and Strong,J.P. (1983). Risk factors and atherosclerotic lesions. A review of autopsy studies. *Arteriosclerosis, Thrombosis and Vascular Biology*, 3, 187-198.
- Srinivasan,R., Zabuawala,T., Huang,H., Zhang,J., Gulati,P., Fernandez,S., Karlo,J.C., Landreth,G.E., Leone,G., and Ostrowski,M.C. (2009). Erk1 and Erk2 regulate endothelial cell proliferation and migration during mouse embryonic angiogenesis. *Public Library of Science One*, 4, e8283.
- Stahli,B.E., Camici,G.G., and Tanner,F.C. (2009). Drug-eluting stent thrombosis. *Therapeutic Advances in Cardiovascular Disease*, 3, 45-52.
- Stauss,H.M., Godecke,A., Mrowka,R., Schrader,J., and Persson,P.B. (1999). Enhanced Blood Pressure Variability in eNOS Knockout Mice. *Hypertension*, 33, 1359-1363.
- Steinberg,D. (1997). Low Density Lipoprotein Oxidation and Its Pathobiological Significance. *Journal of Biological Chemistry*, 272, 20963-20966.

Stephenson,S.L. and Kenny,A.J. (1987). The hydrolysis of alpha-human atrial natriuretic peptide by pig kidney microvillar membranes is initiated by endopeptidase-24.11. *Journal of Biochemistry*, 243, 183-187.

Stevens,H.Y., Melchior,B.t., Bell,K.S., Yun,S., Yeh,J.C., and Frangos,J.A. (2008). PECAM-1 is a critical mediator of atherosclerosis. *Disease Models and Mechanisms*, 1, 175-181.

Stingo,A.J., Clavell,A.L., Heublein,D.M., Wei,C.M., Pittelkow,M.R., and Burnett,J.C. (1992). Presence of C-type natriuretic peptide in cultured human endothelial cells and plasma. *American Journal of Physiology - Heart and Circulatory Physiology*, 263, H1318-H1321.

Sudoh,T., Minamino,N., Kangawa,K., and Matsuo,H. (1990). C-type natriuretic peptide (CNP): a new member of natriuretic peptide family identified in porcine brain. *Biochemical and Biophysical Research Communications*, 168, 863-870.

Sudoh,T., Kangawa,K., Minamino,N., and Matsuo,H. (1988). A new natriuretic peptide in porcine brain. *Nature*, 332, 78-81.

Suga,S., Itoh,H., Komatsu,Y., Ogawa,Y., Hama,N., Yoshimasa,T., and Nakao,K. (1993). Cytokine-induced C-type natriuretic peptide (CNP) secretion from vascular endothelial cells--evidence for CNP as a novel autocrine/paracrine regulator from endothelial cells. *Endocrinology*, 133, 3038-3041.

Suga,S., Nakao,K., Hosoda,K., Mukoyama,M., Ogawa,Y., Shirakami,G., Arai,H., Saito,Y., Kambayashi,Y., Inouye,K., and . (1992a). Receptor selectivity of natriuretic peptide family, atrial natriuretic peptide, brain natriuretic peptide, and C-type natriuretic peptide. *Endocrinology*, 130, 229-239.

Suga,S., Nakao,K., Itoh,H., Komatsu,Y., Ogawa,Y., Hama,N., and Imura,H. (1992b). Endothelial production of C-type natriuretic peptide and its marked augmentation by transforming growth factor-beta. Possible existence of "vascular natriuretic peptide system". *Journal of Clinical Investigation*, 90, 1145-1149.

Suga,S., Nakao,K., Kishimoto,I., Hosoda,K., Mukoyama,M., Arai,H., Shirakami,G., Ogawa,Y., Komatsu,Y., Nakagawa,O., and . (1992c). Phenotype-related alteration in expression of natriuretic peptide receptors in aortic smooth muscle cells. *Circulation Research*, 71, 34-39.

Suga,S., Nakao,K., Mukoyama,M., Arai,H., Hosoda,K., Ogawa,Y., and Imura,H. (1992d). Characterization of natriuretic peptide receptors in cultured cells. *Hypertension*, 19, 762-765.

Sugiyama,S., Kugiyama,K., Matsumura,T., Suga,S.i., Itoh,H., Nakao,K., and Yasue,H. (1995). Lipoproteins Regulate C-Type Natriuretic Peptide Secretion From Cultured Vascular Endothelial Cells. *Arteriosclerosis, Thrombosis and Vascular Biology*, 15, 1968-1974.

Takahara,N., Kashiwagi,A., Nishio,Y., Harada,N., Kojima,H., Maegawa,H., Hidaka,H., and Kikkawa,R. (1997). Oxidized lipoproteins found in patients with

NIDDM stimulate radical-induced monocyte chemoattractant protein-1 mRNA expression in cultured human endothelial cells. *Diabetologia*, 40, 662-670.

Tamura,N., Doolittle,L.K., Hammer,R.E., Shelton,J.M., Richardson,J.A., and Garbers,D.L. (2004). Critical roles of the guanylyl cyclase B receptor in endochondral ossification and development of female reproductive organs. *Proceedings of the National Academy of Sciences*, 101, 17300-17305.

Tamura,N., Ogawa,Y., Chusho,H., Nakamura,K., Nakao,K., Suda,M., Kasahara,M., Hashimoto,R., Katsuura,G., Mukoyama,M., Itoh,H., Saito,Y., Tanaka,I., Otani,H., Katsuki,M., and Nakao,K. (2000). Cardiac fibrosis in mice lacking brain natriuretic peptide. *Proceedings of the National Academy of Sciences*, 97, 4239-4244.

Teng,B., Murthy,K.S., Kuemmerle,J.F., Grider,J.R., Sase,K., Michel,T., and Makhlof,G.M. (1998). Expression of endothelial nitric oxide synthase in human and rabbit gastrointestinal smooth muscle cells. *American Journal of Physiology*, 275, G342-G351.

Thomas,G. (2002). Furin at the cutting edge: From protein traffic to embryogenesis and disease. *Nature Reviews Molecular Cell Biology*, 3, 753-766.

Tokudome,T., Kishimoto,I., Yamahara,K., Osaki,T., Minamino,N., Horio,T., Sawai,K., Kawano,Y., Miyazato,M., Sata,M., Kohno,M., Nakao,K., and Kangawa,K. (2009). Impaired Recovery of Blood Flow After Hind-Limb Ischemia in Mice Lacking Guanylyl Cyclase-A, a Receptor for Atrial and Brain Natriuretic Peptides. *Arteriosclerosis, Thrombosis and Vascular Biology*, 29, 1516-1521.

Tracey,W.R., Pollock,J.S., Murad,F., Nakane,M., and Forstermann,U. (1994). Identification of an endothelial-like type III NO synthase in LLC-PK1 kidney epithelial cells. *American Journal of Physiology - Cell Physiology*, 266, C22-C28.

Traub,O. and Berk,B.C. (1998). Laminar Shear Stress : Mechanisms by Which Endothelial Cells Transduce an Atheroprotective Force. *Arteriosclerosis, Thrombosis and Vascular Biology*, 18, 677-685.

Ueno,H., Haruno,A., Morisaki,N., Furuya,M., Kangawa,K., Takeshita,A., and Saito,Y. (1997). Local Expression of C-Type Natriuretic Peptide Markedly Suppresses Neointimal Formation in Rat Injured Arteries Through an Autocrine/Paracrine Loop. *Circulation*, 96, 2272-2279.

Valli,N., Gobinet,A., and Bordenave,L. (1999). Review of 10 years of the clinical use of brain natriuretic peptide in cardiology. *Journal of Laboratory and Clinical Medicine*, 134, 437-444.

van der Zander,K., Houben,A.J.H.M., Kroon,A.A., De Mey,J.G.R., Smits,P.A.B.M., and de Leeuw,P.W. (2002). Nitric oxide and potassium channels are involved in brain natriuretic peptide induced vasodilatation in man. *Journal of Hypertension*, 20, 493-499.

Vanderheyden,M., Bartunek,J., and Goethals,M. (2004). Brain and other natriuretic peptides: molecular aspects. *European Journal of Heart Failure*, 6, 261-268.

Vane, J.R., Bakhle, Y.S., and Botting, R.M. (1998). Cyclooxygenases 1 and 2. *Annual Review of Pharmacology and Toxicology*, 38, 97-120.

Veale, C.A., Alford, V.C., Aharony, D., Banville, D.L., Bialecki, R.A., Brown, F.J., Damewood, J.R., Dantzman, C.L., Edwards, P.D., Jacobs, R.T., Mauger, R.C., Murphy, M.M., Palmer, W.E., Pine, K.K., Rumsey, W.L., Garcia-Davenport, L.E., Shaw, A., Steelman, G.B., Surian, J.M., and Vacek, E.P. (2000). The discovery of non-basic atrial natriuretic peptide clearance receptor antagonists. part 1. *Bioorganic and Medicinal Chemistry Letters*, 10, 1949-1952.

Veillard, N.R., Kwak, B., Pelli, G., Mulhaupt, F., James, R.W., Proudfoot, A.E.I., and Mach, F. (2004). Antagonism of RANTES Receptors Reduces Atherosclerotic Plaque Formation in Mice. *Circulation Research*, 94, 253-261.

Vermeulen, K., Van Bockstaele, D.R., and Berneman, Z.N. (2003). The cell cycle: a review of regulation, deregulation and therapeutic targets in cancer. *Cell Proliferation*, 36, 131-149.

Villar, I.C., Panayiotou, C.M., Sheraz, A., Madhani, M., Scotland, R.S., Nobles, M., Kemp-Harper, B., Ahluwalia, A., and Hobbs, A.J. (2007). Definitive role for natriuretic peptide receptor-C in mediating the vasorelaxant activity of C-type natriuretic peptide and endothelium-derived hyperpolarising factor. *Cardiovascular Research*, 74, 515-525.

Virmani, R., Kolodgie, F.D., Burke, A.P., Farb, A., and Schwartz, S.M. (2000). Lessons From Sudden Coronary Death : A Comprehensive Morphological Classification Scheme for Atherosclerotic Lesions. *Arteriosclerosis, Thrombosis and Vascular Biology*, 20, 1262-1275.

Vuolteenaho, O., Arjamaa, O., and Ling, N. (1985). Atrial natriuretic polypeptides (ANP): Rat atria store high molecular weight precursor but secrete processed peptides of 25-35 amino acids. *Biochemical and Biophysical Research Communications*, 129, 82-88.

Walcher, D., Babiak, C., Poletek, P., Rosenkranz, S., Bach, H., Betz, S., Durst, R., Grub, M., Hombach, V., Strong, J., and Marx, N. (2006). C-Peptide Induces Vascular Smooth Muscle Cell Proliferation: Involvement of Src-Kinase, Phosphatidylinositol 3-Kinase, and Extracellular Signal-Regulated Kinase 1/2. *Circulation Research*, 99, 1181-1187.

Wang, Y., de Waard, M.C., Sterner-Kock, A., Stepan, H., Schultheiss, H.P., Duncker, D.J., and Walther, T. (2007). Cardiomyocyte-restricted over-expression of C-type natriuretic peptide prevents cardiac hypertrophy induced by myocardial infarction in mice. *European Journal of Heart Failure*, 9, 548-557.

Warner, T.D. and Mitchell, J.A. (2008). COX-2 selectivity alone does not define the cardiovascular risks associated with non-steroidal anti-inflammatory drugs. *The Lancet*, 371, 270-273.

Weber, N.C., Blumenthal, S.B., Hartung, T., Vollmar, A.M., and Kiemer, A.K. (2003). ANP inhibits TNF- α -induced endothelial MCP-1 expression--involvement of p38 MAPK and MKP-1. *Journal of Leukocyte Biology*, 74, 932-941.

Wei,C.M., Heublein,D.M., Perrella,M.A., Lerman,A., Rodeheffer,R.J., McGregor,C.G., Edwards,W.D., Schaff,H.V., and Burnett,J.C. (1993). Natriuretic peptide system in human heart failure. *Circulation*, 88, 1004-1009.

Weir,L., Chen,D., Pastore,C., Isner,J.M., and Walsh,K. (1995). Expression of gax, a growth arrest homeobox gene, is rapidly down-regulated in the rat carotid artery during the proliferative response to balloon injury. *Journal of Biological Chemistry*, 270, 5457-5461.

Weir,M.R. and Dzau,V.J. (1999). The renin-angiotensin-aldosterone system: a specific target for hypertension management. *American Journal of Hypertension*, 12, 205S-213S.

Wennberg,P.W., Miller,V.M., Rabelink,T., and Burnett,J.C. (1999). Further attenuation of endothelium-dependent relaxation imparted by natriuretic peptide receptor antagonism. *American Journal of Physiology - Heart and Circulatory Physiology*, 277, H1618-H1621.

Wiley,K.E. and Davenport,A.P. (2001). Physiological antagonism of endothelin-1 in human conductance and resistance coronary artery. *British Journal of Pharmacology*, 133, 568-574.

Wolf,G. and Wenzel,U.O. (2004). Angiotensin II and Cell Cycle Regulation. *Hypertension*, 43, 693-698.

World Health Organisation. (2010). Cardiovascular disease: prevention and control. *World Health Organisation*.
<http://www.who.int/dietphysicalactivity/publications/facts/cvd/en>.

Wu,C., Wu,F., Pan,J., Morser,J., and Wu,Q. (2003). Furin-mediated Processing of Pro-C-type Natriuretic Peptide. *Journal of Biological Chemistry*, 278, 25847-25852.

Wu,L.W., Mayo,L.D., Dunbar,J.D., Kessler,K.M., Baerwald,M.R., Jaffe,E.A., Wang,D., Warren,R.S., and Donner,D.B. (2000). Utilization of Distinct Signaling Pathways by Receptors for Vascular Endothelial Cell Growth Factor and Other Mitogens in the Induction of Endothelial Cell Proliferation. *Journal of Biological Chemistry*, 275, 5096-5103.

Wu,X., Somlyo,A.V., and Somlyo,A.P. (1996). Cyclic GMP-Dependent Stimulation Reverses G-Protein-Coupled Inhibition of Smooth Muscle Myosin Light Chain Phosphatase. *Biochemical and Biophysical Research Communications*, 220, 658-663.

Yamahara,K., Itoh,H., Chun,T.H., Ogawa,Y., Yamashita,J., Sawada,N., Fukunaga,Y., Sone,M., Yurugi-Kobayashi,T., Miyashita,K., Tsujimoto,H., Kook,H., Feil,R., Garbers,D.L., Hofmann,F., and Nakao,K. (2003). Significance and therapeutic potential of the natriuretic peptides/cGMP/cGMP-dependent protein kinase pathway in vascular regeneration. *Proceedings of the National Academy of Sciences*, 100, 3404-3409.

Yamanaka,A., Ishikawa,T., and Goto,K. (1998). Characterization of Endothelium-Dependent Relaxation Independent of NO and Prostaglandins in Guinea Pig Coronary Artery. *Journal of Pharmacology And Experimental Therapeutics*, 285, 480-489.

Yamashita,J., Itoh,H., Ogawa,Y., Tamura,N., Takaya,K., Igaki,T., Doi,K., Chun,T.H., Inoue,M., Masatsugu,K., and Nakao,K. (1997). Opposite Regulation of Gax Homeobox Expression by Angiotensin II and C-Type Natriuretic Peptide. *Hypertension*, 29, 381-385.

Yan,W., Wu,F., Morser,J., and Wu,Q. (2000). Corin, a transmembrane cardiac serine protease, acts as a pro-atrial natriuretic peptide-converting enzyme. *Proceedings of the National Academy of Sciences*, 97, 8525-8529.

Yang,C.M., Lin,M.I., Hsieh,H.L., Sun,C.C., Ma,Y.H., and Hsiao,L.D. (2005). Bradykinin-induced p42/p44 MAPK phosphorylation and cell proliferation via Src, EGF receptors, and PI3-K/Akt in vascular smooth muscle cells. *Journal of Cellular Physiology*, 203, 538-546.

Yang,X.P., Liu,Y.H., Shesely,E.G., Bulagannawar,M., Liu,F., and Carretero,O.A. (1999). Endothelial Nitric Oxide Gene Knockout Mice : Cardiac Phenotypes and the Effect of Angiotensin-Converting Enzyme Inhibitor on Myocardial Ischemia/Reperfusion Injury. *Hypertension*, 34, 24-30.

Yasuda,S., Kanna,M., Sakuragi,S., Kojima,S., Nakayama,Y., Miyazaki,S., Matsuda,T., Kangawa,K., and Nonogi,H. (2002). Local delivery of single low-dose of C-type natriuretic peptide, an endogenous vascular modulator, inhibits neointimal hyperplasia in a balloon-injured rabbit iliac artery model. *Journal of Cardiovascular Pharmacology*, 39, 784-788.

Yeung,V.T.F., Ho,S.K.S., Nicholls,M.G., and Cockram,C.S. (1996). Binding of CNP-22 and CNP-53 to cultured mouse astrocytes and effects on cyclic GMP. *Peptides*, 17, 101-106.

Yoshizumi,M., Tsuji,H., Nishimura,H., Masuda,H., Kunieda,Y., Kawano,H., Kimura,S., Sugano,T., Kitamura,H., Nakagawa,K., and Nakagawa,M. (1999). Natriuretic peptides regulate the expression of tissue factor and PAI-1 in endothelial cells. *Journal of Thrombosis and Haemostasis*, 82, 1497-1503.

Yu,Y. and Sato,J.D. (1999). MAP kinases, phosphatidylinositol 3-kinase, and p70 S6 kinase mediate the mitogenic response of human endothelial cells to vascular endothelial growth factor. *Journal of Cellular Physiology*, 178, 235-246.

Zachary,I. (2003). VEGF signalling: integration and multi-tasking in endothelial cell biology. *Biochemical Society Transactions*, 31, 1171-1177.

Zahradka,P., Werner,J.P., Buhay,S., Litchie,B., Helwer,G., and Thomas,S. (2002). NF-[kappa]B Activation is Essential for Angiotensin II-dependent Proliferation and Migration of Vascular Smooth Muscle Cells. *Journal of Molecular and Cellular Cardiology*, 34, 1609-1621.

Zambruni,A., Trevisani,F., Gulberg,V., Caraceni,P., Domenicali,M., Cantarini,M.C., Cappa,F.M., Di,M.A., Magini,G., Labate-Morselli,A.M., Gerbes,A.L., and Bernardi,M. (2007). Daily profile of circulating C-type natriuretic peptide in pre-ascitic cirrhosis and in normal subjects: relationship with renal function. *Scandinavian Journal of Gastroenterology*, 42, 642-647.

Zarubin,T. and Han,J. (2005). Activation and signaling of the p38 MAP kinase pathway. *Cell Research*, 15, 11-18.

Zhan,Y., Kim,S., Izumi,Y., Izumiya,Y., Nakao,T., Miyazaki,H., and Iwao,H. (2003). Role of JNK, p38, and ERK in platelet-derived growth factor-induced vascular proliferation, migration, and gene expression. *Arteriosclerosis, Thrombosis and Vascular Biology*, 23, 795-801.

Zhang,W. and Liu,H.T. (2002). MAPK signal pathways in the regulation of cell proliferation in mammalian cells. *Cell Research*, 12, 9-18.

Zhang,Z., Xiao,Z., and Diamond,S.L. (1999). Shear stress induction of C-type natriuretic peptide (CNP) in endothelial cells is independent of NO autocrine signaling. *Annals of Biomedical Engineering*, 27, 419-426.

Zhou,C.H., Xiang,M., He,S.Y., and Qian,Z.Y. (2009). Crocetin inhibits cell cycle G(1)/S transition through suppressing cyclin D1 and elevating p27(kip1) in vascular smooth muscle cells. *Phytotherapy Research*.

Ziche,M., Morbidelli,L., Choudhuri,R., Zhang,H.T., Donnini,S., Granger,H.J., and Bicknell,R. (1997). Nitric oxide synthase lies downstream from vascular endothelial growth factor-induced but not basic fibroblast growth factor-induced angiogenesis. *Journal of Clinical Investigation*, 99, 2625-2634.

Ziegler,T., Bouzourene,K., Harrison,V.J., Brunner,H.R., and Hayoz,D. (1998). Influence of Oscillatory and Unidirectional Flow Environments on the Expression of Endothelin and Nitric Oxide Synthase in Cultured Endothelial Cells. *Arteriosclerosis, Thrombosis and Vascular Biology*, 18, 686-692.