

# A high responsivity, broadband waveguide uni-travelling carrier photodiode (invited paper)

C. C. Renaud (1), M. Robertson (2), D. Rogers (2), R. Firth (2), P. J. Cannard(2), R. Moore(2), A. J. Seeds (1)

1 : Ultra-Fast Photonics Group, Dept of Electrical and Electronic Engineering, University College London, Torrington Place, London WC1E 7JE, UK, Tel: +44(0)20 7679 4464, Fax +44(0)20 7388 9325 email: a.seeds@ee.ucl.ac.uk

2 : Centre For Integrated Photonics, michael.robertson@ciphotonics.com

## ABSTRACT:

**A 0.2 A/W responsivity waveguide-uni-travelling carrier photodiode with a -3 dB electrical frequency response > 107 GHz is demonstrated. Up to -5 dBm electrical power at 110 GHz, and 28 mA photocurrent (DC excitation) were detected. The photodiode was also integrated with an antenna to permit a record breaking emission of up to 148  $\mu$ W at 457 GHz and 25  $\mu$ W at 914 GHz.**

**Keywords:** Photodetector, millimetre-wave, THz source, Heterodyne source, semiconductor.

## I. INTRODUCTION

There is an increasing demand for photodetectors able to detect signals modulated at frequencies above 40 GHz with good linearity and high output power, in order to achieve high dynamic range and high signal to noise ratio for applications such as mm-wave or fibre communication, high data rate optical networking, security imaging (THz) and radio-astronomy.

So far, two main types of high speed detectors have emerged. One is using a technique to match the optical velocity and the electrical velocity in a waveguide structure<sup>1</sup>. This travelling wave structure offered a 3dB bandwidth of 50 GHz with a responsivity of 0.2 A/W<sup>2</sup>. The second is using an electron-only transfer structure as the electron transfer is faster than that for holes. In Uni-Travelling Carrier structures (UTC) the electrons act as the only active carriers and determine photoresponse. These UTC structures (UTC) allowed a 3dB bandwidth of 310 GHz with 0.07 A/W responsivity<sup>3</sup>. The UTC structure has also been used in an evanescently coupled waveguide photodetector scheme<sup>4</sup> to increase the responsivity to 0.7 A/W with a 40 GHz 3dB bandwidth<sup>5</sup>. However neither of these detectors offers high responsivity and very high bandwidth at the same time.

In this paper we report a waveguide UTC device with a -3 dB electrical bandwidth of greater than 108 GHz (measurement limited), a record responsivity for this bandwidth of 0.2 A/W and up to -5 dBm extracted electrical power. We also show results with an integrated resonant antenna with extracted power of 148  $\mu$ W at 457 GHz and 24  $\mu$ W at 914 GHz.

## II. THE STRUCTURE

Figure 1, shows a schematic of the UTC epitaxial structure. The UTC structure used for this work was designed to offer both relatively high coupling from an optical fibre into the detector and short absorption length to reduce the parasitic capacitance. This resulted in an absorption layer thickness such that the carrier transit limited 3dB bandwidth was about 340 GHz. The length of the waveguide device necessary to absorb 90% of the incoming light was calculated to be 15

μm. Considering the characteristics of the structure this will correspond to a 18 fF parasitic capacitance, thus giving a parasitic capacitance limited bandwidth of 350 GHz with a 50 Ω load the bandwidth is most likely to be limited by the electrical characteristics of the fabricated device as the RC limit of the bandwidth for such a capacitance would be 354 GHz, thus of the same order of magnitude as the carrier transit limited 3 dB bandwidth. However, once fabricated the waveguide device was measured to have a parasitic capacitance of only 20-25 fF, which gives a capacitance limited 3dB bandwidth of 254 GHz with a 50 Ω load, which should be our main limitation on the bandwidth of the detector.

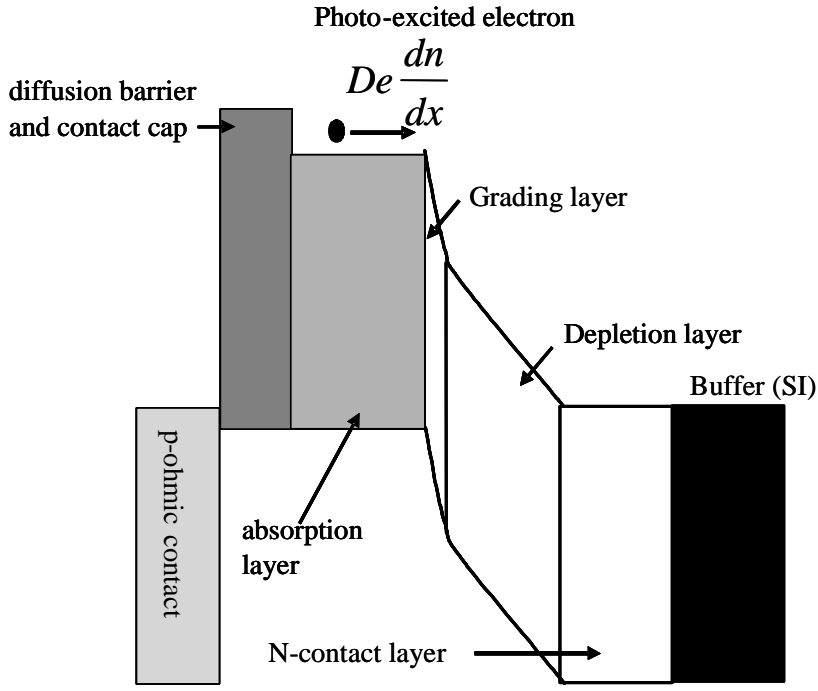

Figure 1: Schematic epitaxial structure

**III. THE PHOTODETECTOR RESPONSIVITY AND BANDWIDTH**

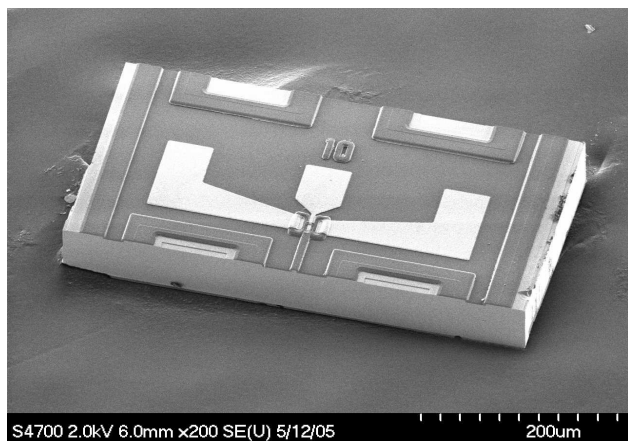

Figure 2: Picture of the fast photodetector with contact pattern for the use of a coplanar probe

Figure 2 shows a picture of the photodetector with contacts for a coplanar probes and the waveguide to couple the light into the detector. The waveguide allowed for a 40% coupling of the light (1550 nm) coming out of a lensed fibre. The contacts were designed to be used with a ground-signal-ground coplanar probe with a 150  $\mu\text{m}$  spacing between the pads. Two probes were used to test the device one for measurement up to 65 GHz and one for measurement between 70 GHz and 110 GHz.

### III.1. Experimental measurement systems

The experimental measurements of the waveguide detector were made using two different systems.

The first was a Lightwave Component Analyser (LCA), used for studies up to 40 GHz. The output of the LCA is a 10 dBm power level optical signal at 1550 nm. At the end of the lensed fibre this drops to 9 dBm. Then by taking the result of simulation for the coupling into the waveguide we can estimate the coupled power into the photodetector to be 5 dBm. After calibration the LCA measured the detector frequency dependent photo-response. The calibration was made with the probe. However this was not a full calibration as it was only made in short and open circuit and not into a load. Note that the 5 dBm estimated input power generated a 635  $\mu\text{A}$  current.

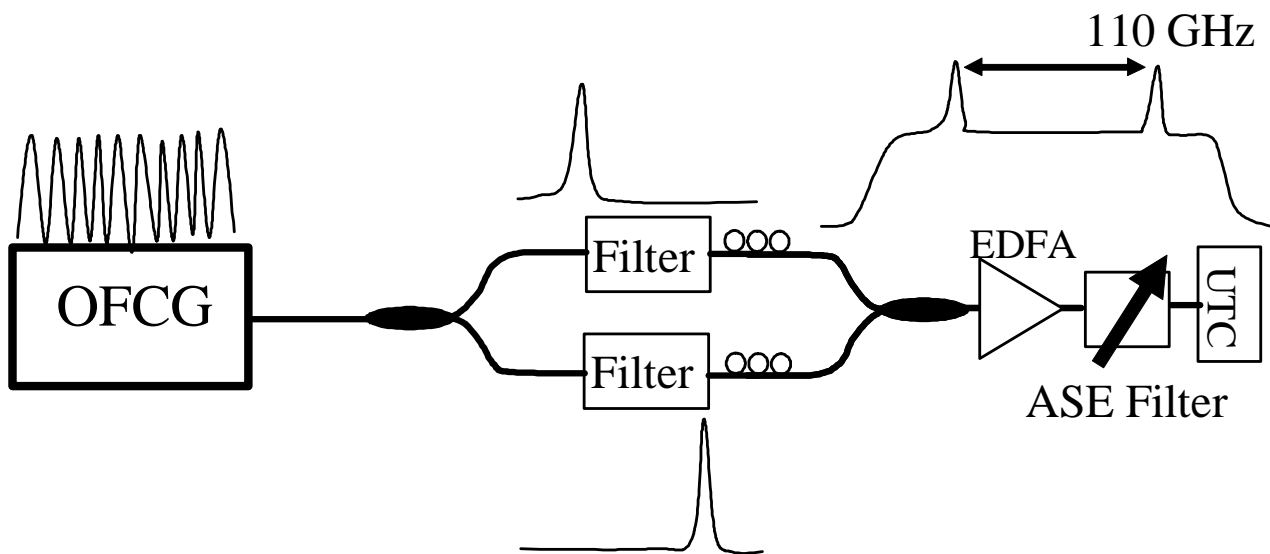

Figure 3: Experimental system used for measurements above 40 GHz

The second, shown in figure 3, used a signal from a heterodyne system based on an optical frequency comb generator<sup>6</sup>, from which two lines were filtered out by tuneable narrow-band filters. The two lines were then combined and amplified to generate a signal at a frequency determined by their separation. The use of such a system allows for the generation of high purity millimetre-wave frequencies<sup>7</sup>. The total saturated output power from the EDFA was 21 dBm, thus the estimated power coupled into the device was 17 dBm. The measured photocurrent at this level of power was 10 mA. However the filter used in this experiment were relatively broad (several comb lines were transmitted) thus the generated signal comprised several beating frequencies. Therefore not all the generated power was at the frequency of interest of the measurement. The resulting signal measured by the probe was then sent to a spectrum analyser.

As stated above, the device was probed with coplanar probes (one for signals from 0 to 65 GHz using coaxial electrical connection and one for signals from 70 to 110 GHz using waveguide electrical connection). The probes were connected to different calibrated harmonic microwave mixers to down-convert the high frequency signals for display on a spectrum analyzer. This resulted in losses of up to 45 dB at 110 GHz (3 dB from the probe and 42 dB from the mixer). The following results are including a frequency dependent loss correction.

### III.2. Experimental results

Using the LCA we measured the dependence of bandwidth with reverse bias and the response up to 40 GHz. The measurements, shown in figure 4, demonstrated that as expected with no reverse bias the -3 dB bandwidth was 1 GHz, at -1 V it was 20 GHz and at -2 V the response was essentially flat (< 1 dB decrease) up to 40 GHz. There was no improvement in bandwidth when the bias was made more negative than -2 V. This was therefore used as the optimum bias for the rest of the experiments. This showed as well that about 10  $\mu$ W power could be extracted from the photodiode with the 5 dBm optical excitation (10 dBm out of the source, 1 dBm lost in connection and transmission, 4dBm lost in coupling).

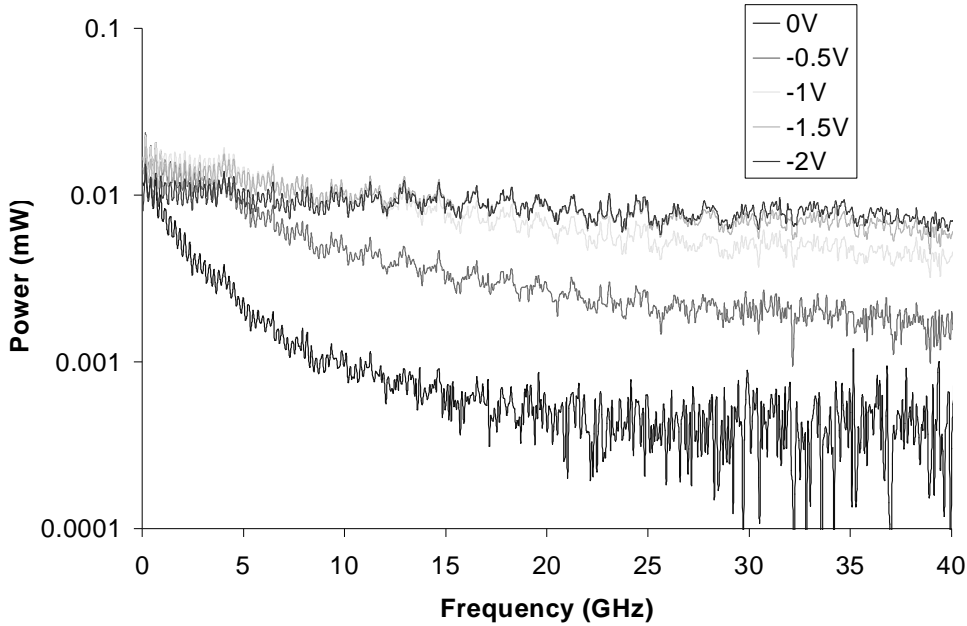

Figure 4: Photodetector response up to 40 GHz with reverse bias from 0 to 2 V

To measure the response at higher frequency the heterodyne system was used. As we were interested in the relative response of the photodetector up to 110 GHz with -2 V bias, points were taken below 40 GHz with the heterodyne measurement system in order to relate them with the previous measurements with the LCA. As seen in figure 5, the experiment showed that the response remains above -3dB up to 108.2 GHz within the error of the measurement. Given the limitation of the coplanar probes and the microwave mixers no measurement was made above 110 GHz. This gives us confidence in claiming that we are limited by our measurement system and the actual 3 dB bandwidth of this detector should be higher than 110 GHz.

Figure 6 shows the mean photocurrent at 110 GHz as a function of the estimated coupled input optical power. This corresponds to a measured responsivity of 0.2 A/W. The measured millimetre-wave power was up to -5 dBm at 108.2 GHz. From the 10 mA mean photocurrent measured and the measured frequency response one would expect up to 2 dBm extracted power. However as stated above the filters in the heterodyne system were not ideal and the power was distributed over different beating frequency, thus the lower than expected extracted power.

In addition, the response was not saturated with the 50 mW optical input (125 mW in the fibre 40% coupling to the detector). Previous measurement (DC) on the same structure grown on N-doped substrate (higher parasitic capacitance devices) showed a higher 0.28 A/W responsivity with no saturation at up to 100 mW (estimated with a 40% coupling) optical input (28 mA photocurrent). Therefore we expect that this device has the potential to generate extracted electrical power of the order of 10 dBm at 110 GHz, for a fully modulated input signal.

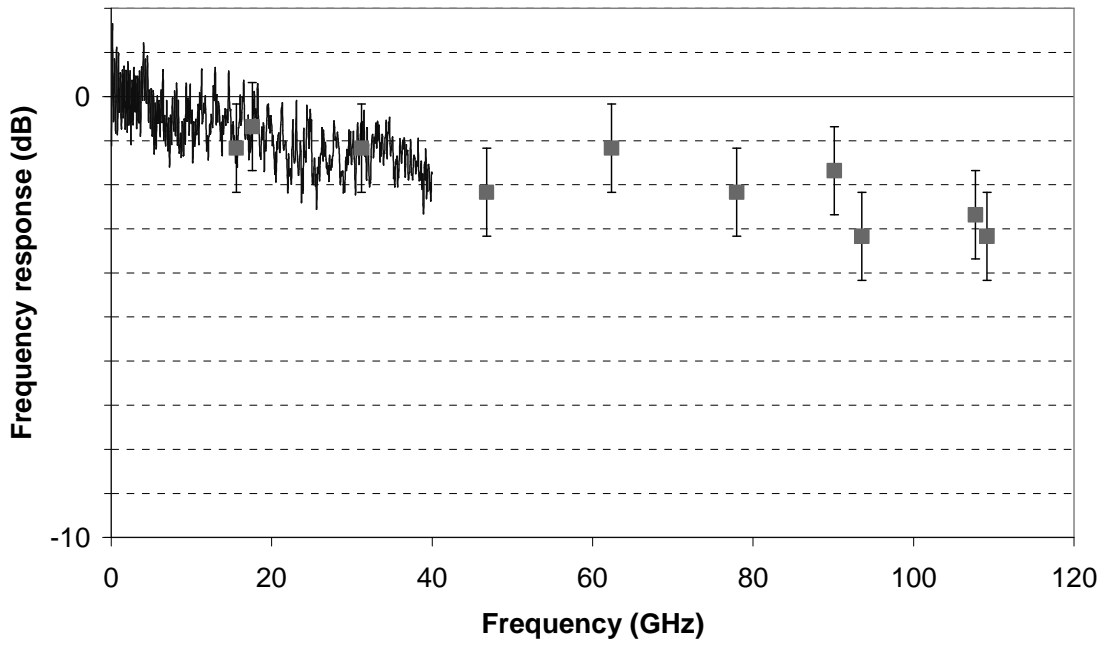

Figure 5: Relative UTC-PD response up to 110 GHz

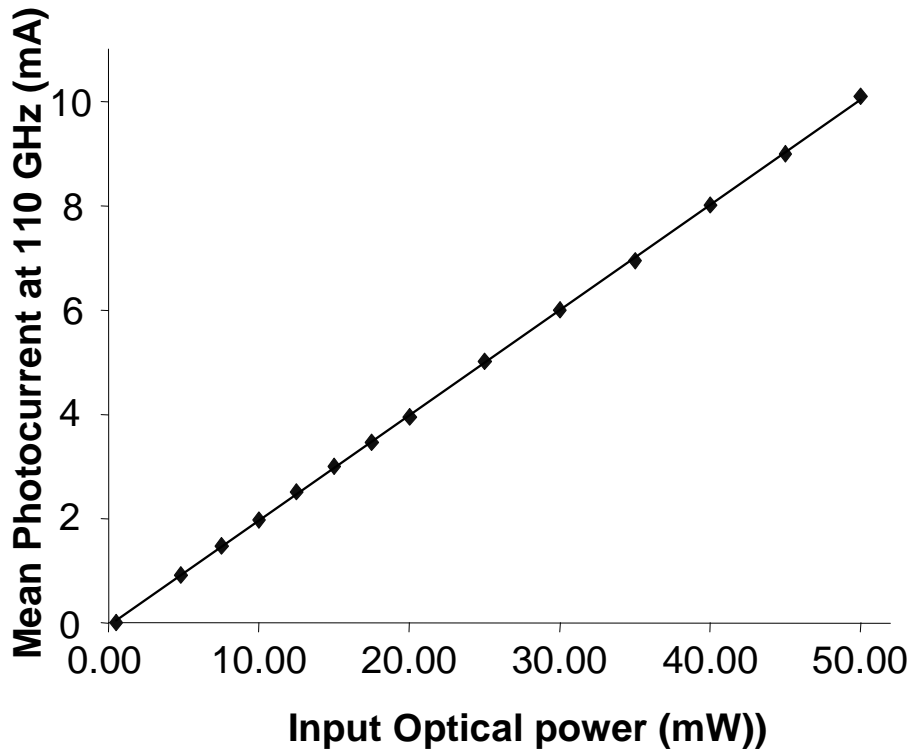

Figure 6: Mean photocurrent response at 110 GHz

#### IV. MILLIMETRE WAVE HETERODYNE GENERATION

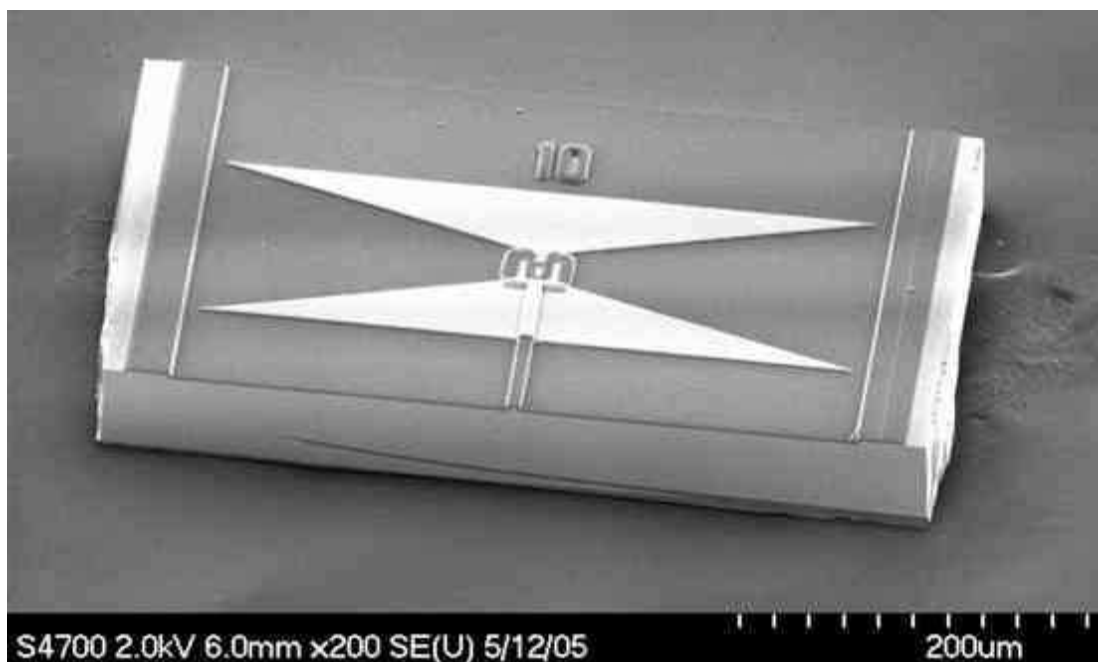

Figure 7: Picture of the photodetector integrated with a bowtie antenna

As shown in figure 7, the photodetector was integrated with an antenna. The one shown in figure 7 is a broadband bowtie antenna with a peak at 800 GHz. The detector was also integrated with a resonant sub-millimetre-wave antenna structure. This allowed measuring the device using free-space techniques.

Figure 8 shows the measurement system using the heterodyne system (with high selectivity filters) to generate high purity frequencies from 100 GHz to 1 THz. The optical power send to the photodiode generated a 10 mA photocurrent. The signal emitted from the antenna was measured using a THz power meter based on a photo-acoustic detector for powers above 10  $\mu\text{W}$  and a bolometer for power under 10  $\mu\text{W}$ . Extra care was taken to filter any residual and parasitic energy that could be measured by the detector. The continuous signal from the EDFA ASE was also estimated and subtracted.

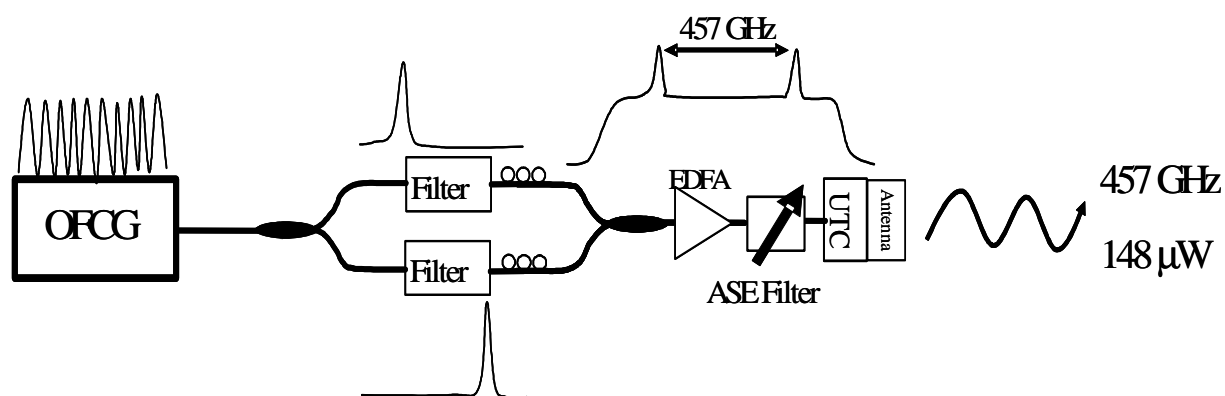

Figure 8: Experimental system for heterodyne generation of THz signal from the photodetector integrated with antenna.

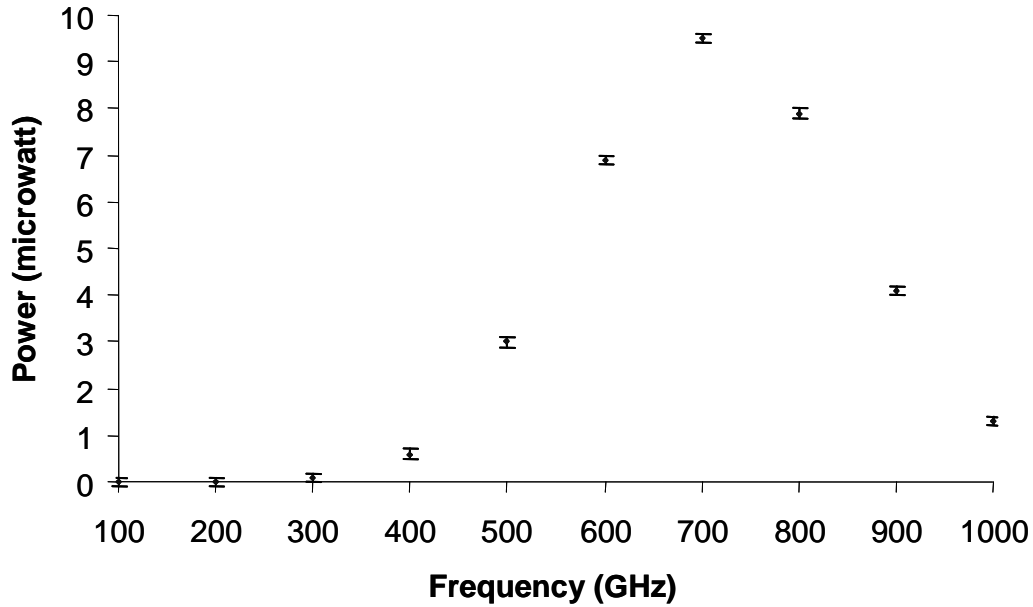

Figure 9: Signal emitted from the bowtie antenna as a function of the Frequency

Figure 9 shows the measured extracted millimetre wave power at different heterodyne frequency. One can see the response of the broadband antenna resulted in a broadband emission around 700 GHz. The maximum extracted power was at 700 GHz with 9.5  $\mu\text{W}$  and there was still more than 1  $\mu\text{W}$  at 1THz. When the device was integrated with a resonant antenna more power could be extracted but only in a narrow band around the resonant frequency. The antenna was designed to have two resonant frequencies around 450 GHz and 900 GHz. During testing, two resonant peaks of emission at 457 GHz and 914 GHz were obtained with record breaking power outputs of 148  $\mu\text{W}$  and 24  $\mu\text{W}$  respectively.

## V. CONCLUSION

This work demonstrates a record high responsivity (0.2 A/W) UTC based waveguide photodiode with up to -5 dBm extracted output power at 110 GHz. It also achieved up to 148  $\mu\text{W}$  emitted at 457 GHz when integrated with a resonant antenna, and up to 9  $\mu\text{W}$  when integrated with a broadband bowtie antenna. However measurement with DC excitation showed that the saturation power of the photodetector is above 200 mW (optical power) coupled into the device. Furthermore the parasitic capacitance measurements suggest that the 3 dB bandwidth of the device should be at least 250 GHz for a 50  $\Omega$  load. Therefore, we expect that this structure can provide much higher bandwidth and higher power. We believe that we should be able to extract up to 7 dBm at 110 GHz (with 200 mW coupled optical power) and emit almost 300  $\mu\text{W}$  at 457 GHz from the photodetector integrated with an antenna.

Future work will concentrate on improving the balance between coupling and bandwidth.

## REFERENCES

- 
- <sup>1</sup> K.S Giboney, M. J. W. Rodwell, J. E. Bowers, "Travelling-wave photodetector theory," *IEEE Trans. Microwave Theory and Tech.*, **45**, pp 1310-19, 1997
- <sup>2</sup> A. Stöhr, R. Heinzlmann, K. Hagedorn, R. Gusten, F. Schafer, H. Stuer, F. Siebe, P. van der Wal, V. Krozer, M. Feiginov, D. Jager, "Integrated 460 GHz photonic transmitter module," *Electron. Letters*, **37**, pp. 1347-48, 2001
- <sup>3</sup> H. Ito, S. Kodama, Y. Muramoto, T. Furuta, T. Nagatsuma, T. Ishibashi, "High-speed and high-output InP-InGaAs untraveling-carrier photodiodes," *IEEE J. of Selected Topics in Quantum Electron*, **10**, pp 709-727, 2004
- <sup>4</sup> J. C. Campbell, S. Demiguel, N. Li, "High-Speed Photodetectors," ECOC 2005 (invited paper), Glasgow, 2005
- <sup>5</sup> M. Achouche, F. Blache, J-G. Provost, E. Derouin, D. Carpentier, S. Vuye, L. Giraudet, M. Goix, F. Jorge, "High speed and high responsivity UTC photodiode module for >40 GB/s optical receivers," OFC 2004, paper TuM4, Los Angeles, 2004
- <sup>6</sup> S. Bennett, B. Cai, E. Burr, O. Gough and A. J. Seeds, "1.8 Terahertz bandwidth, zero frequency error, tunable optical comb generator for DWDM applications," *IEEE Photon. Technol. Lett.*, **11**, pp. 551-553, 1999
- <sup>7</sup> S. Fukushima, C.F.C. Silva, Y. Muramoto, A.J. Seeds, "Optoelectronic synthesis of milliwatt-level multi-octave millimeter-wave signals using an optical frequency comb generator and a untraveling-carrier photodiode," *IEEE Photonics Technology Letters*, **13**, pp. 720-722, 2001