

RIGIDITY OF BROKEN GEODESIC FLOW AND INVERSE PROBLEMS

YAROSLAV KURYLEV, MATTI LASSAS, AND GUNTHER UHLMANN

Abstract. Consider a broken geodesics $\alpha([0, l])$ on a compact Riemannian manifold (M, g) with boundary of dimension $n \geq 3$. The broken geodesics are unions of two geodesics with the property that they have a common end point. Assume that for every broken geodesic $\alpha([0, l])$ starting at and ending to the boundary ∂M we know the starting point and direction $(\alpha(0), \alpha'(0))$, the end point and direction $(\alpha(l), \alpha'(l))$, and the length l . We show that this data determines uniquely, up to an isometry, the manifold (M, g) . This result has applications in inverse problems on very heterogeneous media for situations where there are many scattering points in the medium, and arises in several applications including geophysics and medical imaging. As an example we consider the inverse problem for the radiative transfer equation (or the linear transport equation) with a non-constant wave speed. Assuming that the scattering kernel is everywhere positive, we show that the boundary measurements determine the wave speed inside the domain up to an isometry.

AMS classification: 35J25, 58J45.

Keywords: Rigidity of Riemannian manifolds, broken geodesics, inverse problems, radiative transfer.

1. INTRODUCTION.

1.1. Main result. Let us consider a compact Riemannian manifold (M, g) with boundary of dimension $n \geq 3$. Let SM denote its unit tangent bundle. The classical boundary rigidity problem is the following (see [12, 13, 14, 16, 27, 32, 33, 34, 37, 38]): Assume that we know the distances $d(x, y)$ of boundary points $x, y \in \partial M$. Can we determine the isometry type of the manifold (M, g) ? Michel [30, 31] observed that in the case of simple manifolds these distance functions also determine the values of the bicharacteristic flow at boundary, the so-called scattering relation or lens relation, that is,

$$\mathcal{L} = \{(x, \xi), (y, \zeta), t) \in SM \times SM \times \mathbb{R} : x, y \in \partial M, \\ (\gamma_{x, \xi}(t), \partial_t \gamma_{x, \xi}(t)) = (y, \zeta) \text{ for some } t \geq 0\}$$

where $\gamma_{x, \xi}$ is the geodesic of (M, g) that leaves from x to direction ξ at $t = 0$. In other words, \mathcal{L} gives the information when and where and in which direction a geodesic, sent from the boundary, hits again

the boundary. It was shown in [16] under some conditions (see also [2, 3]) that the wave front set of the scattering operator associated to the wave equation for the Laplace-Beltrami operator of a smooth Riemannian metric determines the scattering relation. The natural conjecture is that for non-trapping manifolds the scattering relation determines the isometry type of the manifold. For recent progress on this problem see the survey papers [35, 40].

In the case of a very heterogeneous media with many scattering points inside the manifold one can obtain further information by looking at the propagation of singularities of waves going through the manifold. This is the broken scattering relation or broken lens relation that we proceed to define.

A broken geodesic (or, a once broken geodesic) is a path $\alpha = \alpha_{x,\xi,z,\eta}(t)$, where $z = \gamma_{x,\xi}(s) \in M$ for some $s \geq 0$, $\eta \in S_z M$, and

$$\alpha_{x,\xi,z,\eta}(t) = \begin{cases} \gamma_{x,\xi}(t), & t < s, \\ \gamma_{z,\eta}(t-s), & t \geq s, \end{cases}$$

(See Fig. 1.) In Riemannian geometry broken geodesics are considered e.g. in the classical Ambrose theorem [4], which says that the parallel translations of the curvature tensor along broken geodesics determine uniquely a simply connected Riemannian manifold.

We denote by $\ell(\alpha_{x,\xi,z,\eta}) \in \mathbb{R}_+ \cup \{\infty\}$ smallest $l > 0$ such that $\alpha_{x,\xi,z,\eta}(l) \in \partial M$. Denote by ν the interior unit normal vector and by

$$\begin{aligned} \Omega_+ &= \{(x, \xi) \in SM : x \in \partial M, (\xi, \nu)_g > 0\}, \\ \Omega_- &= \{(x, \xi) \in SM : x \in \partial M, (\xi, \nu)_g < 0\} \end{aligned}$$

the incoming and outgoing boundary directions respectively.

The boundary entering and exiting points of broken geodesics define the broken scattering relation,

$$\begin{aligned} R &= \{(x, \xi), (y, \zeta), t) \in SM \times SM \times \mathbb{R}_+ : (x, \xi) \in \Omega_+, (y, \zeta) \in \Omega_-, \\ &\quad t = \ell(\alpha_{x,\xi,z,\eta}), \text{ and} \\ &\quad (\alpha_{x,\xi,z,\eta}(t), \partial_t \alpha_{x,\xi,z,\eta}(t)) = (y, \zeta) \text{ for some } (z, \eta) \in SM\}. \end{aligned}$$

Our main result is:

Theorem 1.1. *Let (M, g) be a compact Riemannian manifold with a non-empty boundary of dimension $n \geq 3$. Then ∂M and the broken scattering relation R determines the isometry type of the manifold (M, g) uniquely.*

We remark that this result doesn't assume any a-priori condition on the metric g or the manifold M . The difficulty in proving the result lies in the possible complicated nature of the broken geodesic flow. The proof of the theorem above and the other results stated in the introduction are given in sections 2–3.

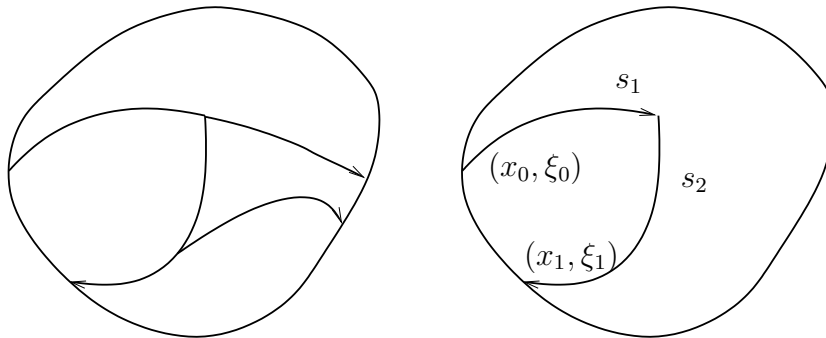

FIGURE 1. Left: Propagation of singularities and multiple scattering for the radiative transfer equation. Right: A broken geodesic corresponding the relation $((x_0, \xi_0), (x_1, \xi_1), t) \in R$ with $t = s_1 + s_2$.

1.2. Application: Radiative transfer equation. As mentioned earlier the broken scattering relation can be determined by probing with waves a very heterogeneous medium with many scattering points and observing at the boundary the effects. The strongest singularities of the waves are the ones propagating through the medium without any reflection and this determines the scattering relation. The next stronger singularities correspond to the waves reflecting only once and this determines the broken scattering relation at the boundary. This type of situation arises in geophysics due to the many discontinuities in the surface of the earth that act as reflectors and in optical tomography, a novel medical imaging technique that allows one to reconstruct the spatial distribution of optical properties of tissues by probing them by near-infra-red photons [6, 7, 17, 18, 20]. This can be formulated as an inverse problem for the radiative transfer equation and we consider this application in more detail below. For previous mathematical analysis on the problem, see e.g. [8, 10, 11, 21, 22, 40].

To avoid artificial difficulties on how to formulate the boundary value problem for the radiative transfer equation, we consider a non-compact complete manifold (N, g) without boundary. The inverse problem we study is to find the metric in a compact subset M with smooth boundary using external measurements made in the set $U = N \setminus M$.

We say that the function $u(t, x, \xi)$ defined on $(t, x, \xi) \in [0, \infty) \times SN$, is a solution of the radiative transfer equation on N if

$$(1) \quad \begin{aligned} (Hu)(t, x, \xi) + \sigma(x, \xi)u(t, x, \xi) - (Su)(t, x, \xi) &= 0, \\ u(t, x, \xi)|_{t=0} &= w(x, \xi). \end{aligned}$$

Here H is the bicharacteristic flow on the tangent bundle TN ,

$$Hu(t, x, \xi) = \frac{\partial u}{\partial t} - \xi^i \frac{\partial u}{\partial x^i} - \xi^i \xi^j \Gamma_{ij}^k(x) \frac{\partial u}{\partial \xi^k},$$

where $(x^1, \dots, x^n, \xi_1, \dots, \xi_n)$ denotes local coordinates on the tangent bundle TN corresponding to local coordinates (x^1, \dots, x^n) of M and $\xi^j = g^{jk}\xi_k$. The operator S , called the scattering operator, is

$$Su(t, x, \xi) = c_n^{-1} \int_{S_x N} K(x, \xi, \xi') u(t, x, \xi') dV_g(\xi').$$

Here $K \in C^\infty(SN \otimes SN)$ is called the scattering kernel and $c_n = \text{vol}(S^{n-1})$. Finally, the function $\sigma \in C^\infty(SN)$ is called the attenuation function. We denote the solution of (1) with the initial value $w \in C^\infty(SN)$ by $u(t, x, \xi) = u^w(t, x, \xi)$.

For the results concerning the radiative transfer equation we need a few more definitions. We say that the complete manifold N is simple if for any $x, y \in N$ there is only one geodesic connecting these points. We say that $M \subset N$ is strictly convex if all points in M can be connected with a geodesic segment lying in M and the second fundamental form of ∂M is positive.

We say that scattering kernel K is positive in M^{int} if

$$K(x, \xi, \xi') > 0, \quad \text{for all } x \in M^{\text{int}} \text{ and } \xi, \xi' \in S_x N.$$

Next we define the external measurements. We assume that for any $w \in C_0^\infty(SN)$, such that $w(x, \xi) = 0$ for $x \in M$ we know solution $u^w(x, \xi, t)$ for $x \in U$. In other words, we assume that we are given the measurement map $A : C_0^\infty(SU) \rightarrow C^\infty(\mathbb{R}_+ \times SU)$,

$$Aw = u^w|_{\mathbb{R}_+ \times SU}.$$

Note that the map A gives us the geodesic flow in U and thus it determines the metric $g_{ij}(x)$ for $x \in U$. Also, it can be used to determine the absorption $\sigma|_U$.

Theorem 1.2. *Let N be a complete simple manifold, $M \subset N$ a compact and strictly convex set with smooth boundary. Assume that $K(x, \theta, \theta')$ vanish for $x \notin M$, that is, $K \in C_0^\infty(SM \otimes SM)$ and that K is positive in M^{int} .*

Moreover, assume that we are given the set $U = N \setminus M$ and the measurement map A . These data determine uniquely the broken scattering relation of the manifold (M, g) .

2. PROOF OF THEOREM 1.1

2.1. Auxiliary Lemmata. Let (M, g) be a compact manifold with boundary, ∂M . In the following, we use an auxiliary smooth closed compact n -manifold $(\widetilde{M}, \widetilde{g})$ that contains (M, g) . We continue to use notation $\gamma_{x, \xi}(t)$, $(x, \xi) \in S\widetilde{M}$, for the geodesics on \widetilde{M} with $\gamma_{x, \xi}(0) = x$ and $\gamma'_{x, \xi}(0) = \xi$. All geodesics are parameterized by the arclength. We denote by $\text{dist}_{\widetilde{M}}(x, y)$ and $\text{dist}(x, y)$ the distance functions on \widetilde{M} and

M , respectively. To simplify notations, we denote

$$(x_0, \xi_0)R_t(x_1, \xi_1) \quad \text{if and only if} \quad \left((x_0, \xi_0), (x_1, -\xi_1), t \right) \in R.$$

On \widetilde{M} and M , we will use various critical distances along geodesics. We start with critical distances associated with the Riemann exponential map, \exp_x ,

$$\exp_x : T_x \widetilde{M} \equiv S_x \widetilde{M} \times \mathbb{R}_+ \longrightarrow \widetilde{M}, \quad \exp_x(s\xi) = \gamma_{x,\xi}(s),$$

$\xi \in S_x \widetilde{M}$, $s \in \mathbb{R}_+$. The *cut locus distance* along $\gamma_{x,\xi}$, denoted by $\tau_R(x, \xi)$, is defined by

$$(2) \quad \tau_R(x, \xi) = \max\{s > 0 : \text{dist}_{\widetilde{M}}(x, \gamma_{x,\xi}(s)) = s\}.$$

The cut locus distance $\tau_R(x, \xi)$, $(x, \xi) \in S\widetilde{M}$ determines the injectivity radius $\text{inj}(M)$ of \widetilde{M} ,

$$\text{inj}(M) = \min_{(x,\xi) \in S\widetilde{M}} \tau_R(x, \xi).$$

We say that the set

$$\omega_x = \{y \in \widetilde{M} : y = \gamma_{x,\xi}(\tau_R(x, \xi)), \xi \in S_x \widetilde{M}\},$$

is the *cut locus* with respect to x . The cut locus ω_x consists of two types of points. We say that a point $y \in \omega_x$ is an *ordinary cut locus point* if there are $\xi, \eta \in S_x \widetilde{M}$, $\eta \neq \xi$ with

$$\tau_R(x, \xi) = \tau_R(x, \eta), \quad \gamma_{x,\xi}(\tau_R(x, \xi)) = \gamma_{x,\eta}(\tau_R(x, \eta)) = y.$$

Consider now the differential of \exp_x at $s\xi$ that is denoted by $d\exp_x|_{s\xi}$. We say that a point $y = \gamma_{x,\xi}(s)$ is a *conjugate point* along $\gamma_{x,\xi}$, if the differential $d\exp_x|_{s\xi} : T_x \widetilde{M} \rightarrow T_y \widetilde{M}$ is degenerate. This is equivalent to the existence of a non-trivial Jacobi field $Y(t)$ along $\gamma = \gamma_{x,\xi}([0, s])$ with the Dirichlet boundary conditions $Y(0) = 0$ and $Y(s) = 0$. For $(x, \xi) \in S\widetilde{M}$ we define the *conjugate distance* $\tau_c(x, \xi) \in \mathbb{R}_+ \cup \{\infty\}$ to be

$$\tau_c(x, \xi) = \inf\{s > 0 : d\exp_x|_{s\xi} \text{ is not one-to-one}\}.$$

Each point $y \in \omega_x$ is an ordinary cut locus point, a first conjugate point, or both.

Next we discuss critical distances associated with the boundary exponential map, $\exp_{\partial M}$,

$$\exp_{\partial M} : \partial M \times \mathbb{R} \longrightarrow \widetilde{M}, \quad \exp_{\partial M}(z, s) = \gamma_{z,\nu}(s), \quad z \in \partial M,$$

where $\nu = \nu(z)$ is the unit interior normal vector to ∂M at z . The pair (z, s) defines the *boundary normal coordinates* in \widetilde{M} near ∂M .

The *boundary cut locus distance*, $\tau_b(z)$, $z \in \partial M$ is given by

$$(3) \quad \tau_b(z) = \max\{s > 0 : \text{dist}(\gamma_{z,\nu}(s), \partial M) = s\}.$$

The set of the corresponding points $y = \gamma_{z,\nu}(\tau_b(z))$ is called the *boundary cut locus*,

$$\omega_{\partial M} = \{y \in M : y = \gamma_{z,\nu}(\tau_b(z)), z \in \partial M\}.$$

The boundary cut locus consists of two types of points. We say that a point $y \in \omega_{\partial M}$ is an *ordinary boundary cut locus point* if there are $z, w \in \partial M$, $z \neq w$ with

$$\tau_b(z) = \tau_b(w), \quad \gamma_{z,\nu}(z)(\tau_b(z)) = \gamma_{w,\nu}(w)(\tau_b(w)) = y.$$

Also, we say that a point $y = \gamma_{z,\nu}(z)(\tau_b(z)) \in \omega_x$ is a *focal point* if the differential, $d \exp_{\partial M} |_{(z,\tau_b(z))} : T_z \partial M \times \mathbb{R} \rightarrow T_y \widetilde{M}$ is degenerate. Equivalently, t is a focal point if there is a non-trivial Jacobi field $Y(t)$ along $\gamma_{z,\nu}([0, s])$ with $Y(s) = 0$ and $Y'(0) = WY(0)$, where W is the Weingarten map of ∂M at z . For $z \in \partial M$, we define the *focal distance*, $\tau_f(z)$ to be

$$\tau_f(z) = \inf\{s > 0 : d \exp_{\partial M} |_{(z,s)} \text{ is not one-to-one}\}.$$

Note that $y \in \omega_{\partial M}$ is an ordinary boundary cut locus point, a first focal point, or both. Also, the functions τ_R , τ_c , τ_b , and τ_f are continuous, e.g. [26].

Comparing Jacobi fields $Y(s)$ along the geodesic $\gamma_{z,\nu}([0, s])$ with the Dirichlet condition $Y(0) = 0$ and the Robin condition $Y'(0) = WY(0)$, we see that $\tau_f(z) < \tau_c(z, \nu)$. Due to the compactness of ∂M there is $c_0 > 0$ such that

$$\tau_c(z, \nu) \geq \tau_f(z) + c_0, \quad z \in \partial M.$$

In a similar manner, we can show that $\tau_R(z, \nu) > \tau_b(z)$, $z \in \partial M$. Indeed, assume the opposite, i.e., $t = \tau_R(z, \nu) \leq \tau_b(z)$ for some $z \in \partial M$. Denote $(y, \eta) = (\gamma_{z,\nu}(t), -\gamma'_{z,\nu}(t))$. By duality, $\tau_R(y, \eta) = \tau_R(z, \nu) = t$. Let $\varepsilon > 0$ and $x_\varepsilon = \gamma_{z,\nu}(-\varepsilon) = \gamma_{y,\eta}(t + \varepsilon)$. Then

$$\text{dist}_{\widetilde{M}}(x_\varepsilon, y) < t + \varepsilon \leq \tau_b(z) + \varepsilon$$

and there is $\eta_\varepsilon \in S_{x_\varepsilon} \widetilde{M}$ with $y = \gamma_{x_\varepsilon, \eta_\varepsilon}(\text{dist}_{\widetilde{M}}(x_\varepsilon, y))$. Denote by $t_\varepsilon > 0$ the last time when $\gamma_{x_\varepsilon, \eta_\varepsilon}(s)$ hits ∂M . If ε is sufficiently small, we see by the short-cut arguments that $\text{dist}(y, \partial M) < \tau_b(z)$. This contradicts the definition of τ_b in (3).

Due to the compactness of ∂M , by making $c_0 > 0$ smaller if necessary,

$$(4) \quad \tau_R(z, \nu) \geq \tau_b(z) + c_0, \quad z \in \partial M.$$

Later we will consider intersections of various geodesics on M . In these considerations we would like to avoid pathological cases that may happen to long geodesics. The first case we analyze is a self-intersection of a geodesic.

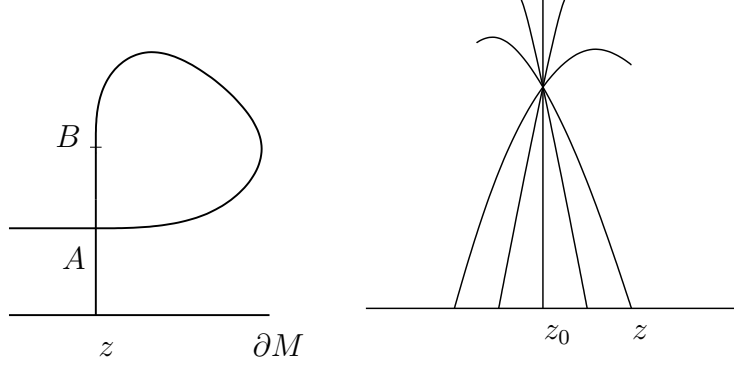

FIGURE 2. Left: Self-intersection of a normal geodesic. Right: Geodesics corresponding to focusing directions.

Lemma 2.1. *Let $\gamma_{z,\nu}$, $z \in \partial M$ be the normal geodesic and*

$$\gamma_{z,\nu}(s_+) = \gamma_{z,\nu}(s_-), \quad s_+ > s_-,$$

that is, $\gamma_{z,\nu}$ intersects itself. Then $s_+ + s_- > 2\tau_R(z, \nu)$.

Proof. Assume that

$$(5) \quad s_+ + s_- \leq 2\tau_R(z, \nu).$$

Then $s_- < \tau_R(z, \nu)$. Let $A = \gamma_{z,\nu}(s_-)$, $B = \gamma_{z,\nu}(\tau_R(z, \nu))$ be points on $\gamma_{z,\nu}$, see Fig. 2, and denote by $l_{BA} = s_+ - \tau_R(z, \nu)$ the length of the "long" geodesic $\gamma_{z,\nu}([\tau_R(z, \nu), s_+])$. Then, using definition (2) of τ_R , $s_- = \text{dist}(z, A)$, $\tau_R(z, \nu) - s_- = \text{dist}(A, B)$, so that the length of the broken geodesic $\gamma_{z,\nu}([0, s_+]) \cup \gamma_{z,\nu}([0, s_-])$ from z to z is

$$s_+ + s_- = \text{dist}(z, A) + \text{dist}(A, B) + l_{BA} + \text{dist}(A, z).$$

Since $\gamma_{z,\nu}([s_-, \tau_R(z, \nu)])$ is the unique minimal geodesic between its endpoints, $l_{BA} > \text{dist}(A, B) = \tau_R(z, \nu) - s_-$. Therefore,

$$s_+ + s_- > s_- + (\tau_R(z, \nu) - s_-) + (\tau_R(z, \nu) - s_-) + s_- = 2\tau_R(z, \nu),$$

which contradicts (5). \square

In the sequel, dist_S is the Sasakian distance on, depending on the context, $T\widetilde{M}$ or $S\widetilde{M}$, see [36].

Lemma 2.2. *Let $\varepsilon > 0$, $z \in \partial M$. There is $\delta = \delta(\varepsilon) > 0$ such that if*

$$(z_1, \xi_1) R_{2t}(z_2, \xi_2), \quad \text{i.e. } \gamma_{z_1, \xi_1}(t_1) = \gamma_{z_2, \xi_2}(t_2), \quad t_1 + t_2 = 2t,$$

with $t < \tau_R(z, \nu) + \delta$ and $\text{dist}_S((z_i, \xi_i), (z, \nu)) < \delta$, $i = 1, 2$ then

$$|t - t_i| < \varepsilon, \quad i = 1, 2.$$

Note that the constant δ does not depend on $z \in \partial M$.

Proof. Assume the opposite, i.e., an existence of points $z^k \in \partial M$, $(z_i^k, \xi_i^k) \in \Omega_+$, $k = 1, 2$, $i = 1, 2, \dots$ and a parameter $\varepsilon > 0$, such that

$$\lim_{k \rightarrow \infty} \text{dist}_S((z_i^k, \xi_i^k), (z^k, \nu^k)) = 0,$$

$$\gamma_{z_1^k, \xi_1^k}(t_1^k) = \gamma_{z_2^k, \xi_2^k}(t_2^k), \quad t_1^k + t_2^k = 2t^k, \quad \limsup_{k \rightarrow \infty} (t^k - \tau_R(z^k, \nu^k)) \leq 0,$$

with $t_1^k - t_2^k \geq 2\varepsilon$. Using continuity arguments and compactness of ∂M we have that there is a subsequence $k(p)$ with $z^{k(p)} \rightarrow z$, $t_1^{k(p)} \rightarrow t^+$, $t_2^{k(p)} \rightarrow t^-$, and

$$\gamma_{z, \nu}(t_+) = \gamma_{z, \nu}(t_-), \quad t_+ + t_- \leq 2\tau_R(z, \nu), \quad t_+ - t_- \geq 2\varepsilon,$$

which contradicts Lemma 2.1. \square

Next we introduce auxiliary functions $\mu_1(z)$, $\mu_2(z)$, and $\tau_M(z)$, $z \in \partial M$ with $\mu_1(z)$ and $\mu_2(z)$ to be determined from the broken scattering relation. The function $\mu_1(z)$ tells when a normal geodesics sent from $z \in M$ exits M . By the definition of the broken scattering relation, R , a point $(z, \xi) \in \Omega_+$ is in relation with itself, $(z, \xi)R_t(z, \xi)$, if and only if the geodesic $\gamma_{z, \xi}((0, t/2])$ on \widetilde{M} lies in M^{int} . This makes it possible to determine, for any $\gamma_{z, \xi}$, $(z, \xi) \in \Omega_+$, its arclength to the first hitting point to ∂M . We denote this arclength by $\mu_1(z, \xi)$ and $\mu_1(z) = \mu_1(z, \nu)$.

The function $\mu_2(z)$ is an approximation to $\tau_f(z)$. If we want to determine $\tau_f(z)$ we can argue as follows: assume that $s > \tau_f(z)$. Then the normal geodesic $\gamma_{z, \nu}([0, s])$ is no longer a shortest path from $\gamma_{z, \nu}(s)$ to ∂M and there are sequences $z_n \rightarrow z$, $z_n \neq z$, $s_n \rightarrow \tau_f(z)$, $t_n \rightarrow \tau_f(z)$ such that

$$\gamma_{z, \nu}(s_n) = \gamma_{z_n, \nu_n}(t_n), \quad \nu_n = \nu(z_n).$$

In terms of the relation R , these imply that

$$(6) \quad (z, \nu) R_{T_n}(z_n, \nu_n), \quad T_n = t_n + s_n,$$

$$\text{with } s_n \rightarrow \tau_f(z), t_n \rightarrow \tau_f(z), z_n \rightarrow z, \text{ when } n \rightarrow \infty.$$

Therefore, it makes sense to try to find $\tau_f(z)$ using (6). However, there are two obstacles. First, it may happen that $\tau_f(z) \geq \mu_1(z)$. Second, having (6) with $z_n \rightarrow z$, $T_n \rightarrow 2t$, we want to conclude that $s_n \rightarrow t$, $t_n \rightarrow t$. To do so, we intend to use Lemma 2.2, which requires $t \leq \tau_R(z, \nu)$ which is not known. To avoid these difficulties, we will not determine $\tau_f(z)$ but another function $\mu_2(z)$ that is closely related to it.

Definition 2.3. Consider the set $S(z)$ of those $s \in (0, \mu_1(z))$ for which there are sequences $z_n \rightarrow z$, $z_n \in \partial M$, $z_n \neq z$, $T_n \rightarrow 2s$ such that

$$(7) \quad (z_n, \nu_n) R_{T_n}(z, \nu).$$

Define $\mu_2(z) = \inf S(z)$, if $S(z) \neq \emptyset$ and $\mu_2(z) = \mu_1(z)$ otherwise.

Observe that μ_2 may be found from the broken scattering relation.

Lemma 2.4. Function $\mu_2 : \partial M \rightarrow \mathbb{R}_+$ satisfies

$$(8) \quad \min(\mu_1(z), \tau_f(z), \tau_R(z, \nu)) \leq \mu_2(z) \leq \min(\mu_1(z), \tau_f(z)).$$

and $\tau_b(z) \leq \mu_2(z)$.

Proof. The right inequality in (8) follows from Definition 2.3 and considerations before it.

To prove the left inequality of (8), let us assume that there is $s < \min(\tau_f(z), \mu_1(z), \tau_R(z, \nu))$ which satisfies (7). By Lemma 2.2, applicable due to $T_n < 2\tau_R(z, \nu)$ for large n , we have

$$(9) \quad \gamma_{z_n, \nu_n}(s_n) = \gamma_{z, \nu}(s'_n), \quad s_n \rightarrow s, \quad s'_n \rightarrow s, \quad z_n \rightarrow z, \quad z_n \neq z.$$

As $s < \tau_f(z)$, $\exp_{\partial M}$ is a local diffeomorphism near (z, s) , which contradicts (9). This proves (8).

Using definitions μ_1 and τ_f , we see by using (4) that

$$\tau_b(z) \leq \min\left(\frac{1}{2}\mu_1(z), \tau_f(z), \tau_R(z, \nu(z))\right).$$

This yields $\tau_b(z) \leq \mu_2(z)$. \square

Finally, we need a function $\tau_M(z)$ with $\tau_M(z) > \tau_b(z)$ having the property that, for $t < \tau_M(z)$ the geodesics sent back from a point $x = \gamma_{z, \nu}(t)$ hit the boundary ∂M near z in a regular way. Namely, we define

$$\tau_M(z) = \min(\mu_1(z), \tau_R(z, \nu(z))), \quad z \in \partial M.$$

As $\tau_b(z) \leq \frac{1}{2}\mu_1(z)$ we see by (4) that $\tau_b(z) < \tau_M(z)$.

2.2. Family of intersecting geodesics. In this section we intend to use the broken scattering relation to verify if a given family of geodesics intersect at one point.

Let $z_0 \in \partial M$, $\nu_0 = \nu(z_0)$, and $x_0 = \gamma_{z_0, \nu_0}(t_0)$, $0 < t_0 < \tau_M(z_0)$. Denote $\eta_0 = -\gamma'_{z_0, \nu_0}(t_0)$. Clearly, η_0 is the direction of the reverse geodesic, γ_{x_0, η_0} from x_0 to z_0 . By considering Jacobi fields along this geodesic, we see that the exponential map, $\exp_{x_0} : S_{x_0}\widetilde{M} \times \mathbb{R}_+ \rightarrow \widetilde{M}$, is a local diffeomorphism near (η_0, t_0) .

As $t_0 < \tau_R(x_0, \eta_0)$ and $\gamma_{x_0, \eta_0}(t_0)$ hits ∂M normally, all geodesics $\gamma_{x_0, \eta}$ hit ∂M transversally for $\eta \in S_{x_0}M$ close to η_0 . They determine smooth functions $z(\eta)$, $t(\eta)$ such that $\gamma_{x_0, \eta}(t(\eta)) = z(\eta) \in \partial M$. Inverting these functions and using transversality, we obtain, in a neighborhood $U \subset \partial M$ of z_0 a smooth section $\xi(z) : U \rightarrow SU$ and a function $t(z)$ such that

$$(10) \quad \gamma_{z, \xi(z)}(t(z)) = x_0, \quad z \in U.$$

In the following, our aim is to determine, using the broken scattering relation R , whether, for a given triple $\{U, \xi(\cdot), t(\cdot)\}$ of a neighborhood $U \subset \partial M$ and functions $\xi(z)$ and $t(z)$, there exists a point $x_0 \in M$ such that $\gamma_{z, \xi(z)}(t(z)) = x_0$ for all $z \in U$.

To this end, we notice that property (10) implies

$$(11) \quad (z, \xi(z)) R_{T(z)}(z_0, \nu_0), \quad (z, \xi(z)) R_{T(z, z')}(z', \xi(z')), \quad z, z' \in U, \\ T(z) = t(z) + t_0, \quad T(z, z') = t(z) + t(z'),$$

for smooth $\xi(z)$, $t(z)$. In addition,

$$(12) \quad t(z_0) = t_0, \quad dt(z)|_{z_0} = 0, \quad \xi(z_0) = \nu(z_0),$$

where the last properties follow from the fact that γ_{x_0, η_0} is normal to ∂M . Here, $dt(z) = d_z t(z)$ is the differential of the function $t : U \rightarrow \mathbb{R}$.

These observations motivate the following definition:

Definition 2.5. *Let $z_0 \in \partial M$ and $t_0 > 0$. Consider a family $\mathcal{F}(z_0, t_0) = \{U, \xi(\cdot), t(\cdot)\}$ where $U \subset \partial M$ is a neighborhood of z_0 , $\xi : U \rightarrow SM$ is a smooth section, and $t : U \rightarrow \mathbb{R}$ is a smooth function. We say that $\mathcal{F}(z_0, t_0)$ is a family of focusing directions if $\xi(z)$, $t(z)$ satisfy conditions (11) and (12). We then say that the geodesics $\gamma_{z, \xi(z)}$, $z \in U$ are the geodesics corresponding to family $\mathcal{F}(z_0, t_0)$.*

Note that the broken scattering relation R determines if given U , $\xi(z)$, and $t(z)$ form a family of focusing directions. Our principal technical result in this section shows that the geodesics corresponding to a family of focusing directions intersect at a single point.

Theorem 2.6. *Let $z_0 \in \partial M$, $t_0 < \tau_M(z_0)$, and $\mathcal{F}(z_0, t_0)$ be a family of focusing directions. Then there is a neighborhood $\tilde{U} \subset U$ of z_0 such that*

$$\gamma_{z, \xi(z)}(t(z)) = \gamma_{z_0, \nu_0}(t_0), \quad \text{for all } z \in \tilde{U}.$$

Proof. The proof of this result is rather long and will consist of several steps and auxiliary lemmata.

Step 1. We start with an observation that (11) implies that, for any $z \in U$, there are $s(z)$, $\widehat{s}(z) \geq 0$ such that

$$x(z) = \gamma_{z, \xi(z)}(s(z)) = \gamma_{z_0, \nu_0}(\widehat{s}(z)), \quad s(z) + \widehat{s}(z) = T(z).$$

As $t_0 < \tau_R(z_0, \nu_0)$, by Lemma 2.2 $s(z) \rightarrow t_0$, $\widehat{s}(z) \rightarrow t_0$ when $z \rightarrow z_0$ and

$$(13) \quad s(z_0) = \widehat{s}(z_0) = t_0.$$

Next we show that $s(z)$, $\widehat{s}(z)$ are C^∞ -smooth near z_0 and

$$(14) \quad ds(z)|_{z_0} = d\widehat{s}(z)|_{z_0} = 0.$$

To this end, consider the function $H(s, z)$,

$$H(s, z) = \text{dist}(\gamma_{z_0, \nu_0}(s), z) + s - T(z), \quad (s, z) \in (t_0 - \delta, t_0 + \delta) \times U.$$

As $t_0 < \tau_R(z_0, \nu_0)$, the function $H(s, z)$ is C^∞ -smooth a neighborhood of (t_0, z_0) and

$$H(t_0, z_0) = 0, \quad \partial_s H(t_0, z_0) = \partial_s \text{dist}(\gamma_{z_0, \nu_0}(s), z_0)|_{t_0} + 1 = 2.$$

Making U smaller if necessary, the equation $H(s, z) = 0$ has a unique solution $s = \widetilde{s}(z)$ which is C^∞ -smooth in U with $\widetilde{s}(z_0) = t_0$. As also $s = \widehat{s}(z)$ solves $H(s, z) = 0$, we see that $\widehat{s}(z) = \widetilde{s}(z)$, $z \in U$. It then follows that $s(z) = T(z) - \widehat{s}(z) \in C^\infty(U)$.

Let us differentiate the identity $H(\widehat{s}(z), z) = 0$ with respect to z at $z = z_0$. Due to (12) and the fact that γ_{z_0, ν_0} is normal to ∂M ,

$$0 = d_z H(\widehat{s}(z), z)|_{z_0} = d_z \widehat{s}|_{z_0} \cdot (\partial_s \text{dist}(\gamma_{z_0, \nu_0}(s), z_0)|_{s=t_0} + 1) = 2d_z \widehat{s}|_{z_0}.$$

Thus, $d_z \widehat{s}|_{z_0} = 0$ and also $d_z s|_{z_0} = d_z (T(z) - \widehat{s}(z))|_{z_0} = 0$.

Step 2. Consider the map $E \in C^\infty(U; SM)$,

$$E(z) = (x(z), \eta(z)) := (\gamma_{z, \xi(z)}(s(z)), -\gamma'_{z, \xi(z)}(s(z))), \quad E(z_0) = (x_0, \eta_0).$$

Lemma 2.7. *The map $dE|_{z_0} : T_{z_0} \partial M \rightarrow T_{x_0, \eta_0} SM$ has the form*

$$(15) \quad dE|_{z_0}(v) = (0, \Theta v), \quad v \in T_{z_0} \partial M,$$

where we identify $T_{x_0, \eta_0} SM \approx T_{x_0} M \times T_{\eta_0}(S_{x_0} M)$. Furthermore, $\Theta : T_{z_0} \partial M \rightarrow T_{\eta_0}(S_{x_0} M)$ is bijective.

Proof of Lemma 2.7. As $x(z) = \gamma_{z_0, \nu_0}(\widehat{s}(z))$, it follows from (14) that $dx|_{z_0} = 0$, i.e., $dE|_{z_0}$ is of form (15). To show that Θ is bijective, observe that

$$(16) \quad \exp_{x(z)}(s(z)\eta(z)) = z, \quad z \in U.$$

Let us denote $\text{Exp}(x, \xi) = \exp_x \xi$, $(x, \xi) \in T\widetilde{M}$. By differentiating both sides of (16) with respect to z and using $dx|_{z_0} = 0$, we obtain

$$d_\xi \text{Exp}|_{(x_0, t_0 \eta_0)} \left(s(z_0) \Theta \zeta + (ds|_{z_0} \zeta) \eta(z_0) \right) = \zeta$$

for any $\zeta \in T_{z_0} \partial M$. Using that $s(z_0) = t_0$, $ds|_{z_0} = 0$, we get

$$d_\xi \exp_{x_0}|_{\xi=t_0 \eta_0} (t_0 \Theta \zeta) = \zeta,$$

which implies that $\Theta : T_{z_0} \partial M \rightarrow T_{\eta_0}(S_{x_0} M)$ is bijective. \square

Step 3. Our further considerations are based on the analysis of the intersection of a single geodesic and the geodesics corresponding to a family of focusing directions.

Lemma 2.8. *Let $z_0 \in \partial M$ and $\mathcal{F}(z_0, t_0) = \{U, \xi(\cdot), t(\cdot)\}$, $t_0 < \tau_M(z_0)$ be a family of focusing directions. Let $\gamma(\tau)$ be another geodesic in M which intersects γ_{z_0, ν_0} ,*

$$(17) \quad \gamma(0) = \gamma_{z_0, \nu_0}(r_0), \quad \gamma'(0) \neq \pm \gamma'_{z_0, \nu_0}(r_0), \quad r_0 < \tau_M(z_0).$$

Assume, in addition, that all geodesics $\gamma_{z, \xi(z)}$ corresponding to $\mathcal{F}(z_0, t_0)$ intersect γ near y_0 , i.e.,

$$(18) \quad \gamma_{z, \xi(z)}(r(z)) = \gamma(\tau(z)),$$

where $0 < r(z) \leq r_1 < \tau_M(z_0)$ and $|\tau(z)| \leq i_1 < \text{inj}(M)$. Then $r_0 = t_0$.

Proof of Lemma 2.8. Denote $y_0 = \gamma_{z_0, \nu_0}(r_0)$. First we show that $r(z)$ is continuous at z_0 . If this is not true, there would be another intersection of γ_{z_0, ν_0} and γ ,

$$\gamma_{z_0, \nu_0}(r') = \gamma(\tau'), \quad r' \leq r_1, \quad r' \neq r_0, \quad |\tau'| < \text{inj}(M).$$

This leads to a contradiction as both $\gamma([0, \tau'])$ and $\gamma_{z_0, \nu_0}([r_0, r'])$ are unique minimal geodesics between their endpoints. Thus $r(z)$ is continuous at z_0 .

To prove the claim, we assume that $r_0 \neq t_0$. Our next goal is to show that the map $\Psi : U \times \mathbb{R}_+ \rightarrow M$,

$$\Psi(z, r) = \exp_z(r\xi(z))$$

is a local diffeomorphism near (z_0, r_0) , see the right part of Fig. 3. Indeed, as $t_0, r_0 < \tau_R(z_0, \nu_0)$, the map \exp_{x_0} is a local diffeomorphism near $(t_0 - r_0)\eta_0$, where $x_0 = \gamma_{z_0, \nu_0}(t_0)$, $\eta_0 = -\gamma'_{z_0, \nu_0}(t_0)$. Thus,

$$d\exp_{x_0}|_{(t_0-r_0)\eta_0} : T_{(t_0-r_0)\eta_0}(T_{x_0}M) \rightarrow T_{y_0}M$$

is bijective. Using the definitions for $s(z)$, $E(z) = (x(z), \eta(z))$ introduced earlier we have

$$\Psi(z, r) = \gamma_{E(z)}(s(z) - r) = \exp_{x(z)}((s(z) - r)\eta(z)).$$

By (13) and (14), $ds(z)|_{z_0} = 0$ and $s(z_0) = t_0$, which together with (15) imply that

$$d\Psi|_{(z_0, r_0)}(\zeta, \rho) = d\exp_{x_0}|_{(t_0-r_0)\eta_0}((t_0 - r_0)\Theta\zeta - \rho\eta_0)$$

for $\zeta \in T_{z_0}\partial M$ and $\rho \in \mathbb{R}$. Thus, by Lemma 2.7 and bijectivity of $d\exp_{x_0}|_{(t_0-r_0)\eta_0}$,

$$d\Psi|_{(z_0, r_0)} : T_{z_0}\partial M \times \mathbb{R} \rightarrow T_{y_0}M$$

is bijective, i.e., Ψ is a local diffeomorphism near (z_0, r_0) .

Now, let Σ be an $(n - 1)$ -dimensional submanifold which contains a part $\gamma(-\varepsilon, \varepsilon)$ of γ near y_0 and is transversal to γ_{z_0, ν_0} at y_0 , see Fig. 3, the existence of such submanifold guaranteed by (17). Introducing the boundary normal coordinates (w, n) associated to Σ , with $n = 0$ on Σ , we rewrite Ψ in these coordinates as

$$\Psi(z, r) = (w(z, r), n(z, r)).$$

By transversality, $\frac{\partial n}{\partial r}(z_0, r_0) \neq 0$. This implies that for any z near z_0 the equation $n(z, r) = 0$ has a unique solution $r = \hat{r}(z)$. Moreover, $\hat{r}(z_0) = r_0$ and the function $\hat{r}(z)$ is smooth in a neighborhood of z_0 .

Now $r(z)$ and $\hat{r}(z)$ are continuous at z_0 and they both solve the equation $n(z, r) = 0$. Thus, there is a neighborhood $\tilde{U} \subset U$ of z_0 such that $\hat{r}(z) = r(z)$ for $z \in \tilde{U}$. As also Ψ is a local diffeomorphism, we see that if \tilde{U} is small enough, then $\tilde{\Psi} : \tilde{U} \rightarrow \tilde{\Psi}(\tilde{U}) \subset \Sigma$, where $\tilde{\Psi}(z) = \Psi(z, r(z))$, is a diffeomorphism of $(n - 1)$ -dimensional submanifolds. On the other hand, condition (18) implies that $\tilde{\Psi}(\tilde{U}) \subset \gamma(-\varepsilon, \varepsilon)$. As $\gamma(-\varepsilon, \varepsilon)$ is a one-dimensional submanifold of Σ , we get a contradiction for $n \geq 3$. Thus, $r_0 = t_0$. \square

Step 4. Let $0 < \varepsilon < \frac{1}{4} \min(\text{inj}(M), \tau_R(z_0, \nu) - t_0)$ and $0 < \delta < \delta(\varepsilon)$ where $\delta(\varepsilon)$ is defined in Lemma 2.2. We choose a neighborhood $\tilde{U} \subset U$

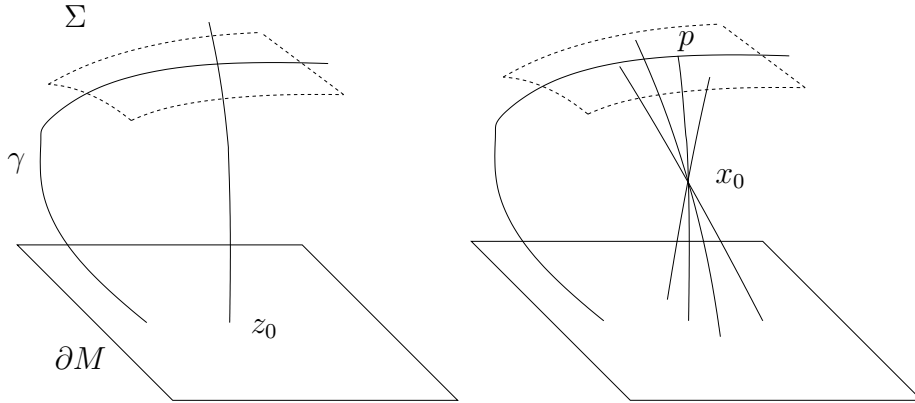

FIGURE 3. Left: Submanifold Σ contains geodesic γ and is transversal to $\gamma_{z_0, \nu}$. Right: Geodesics corresponding to $\mathcal{F}(z_0, t_0)$ almost intersect at the point $x_0 = \gamma_{z_0, \nu}(t_0)$ and define coordinates near $p = \gamma_{z_0, \nu}(r_0)$.

of z_0 so that

$$|t(z) - t_0| < \varepsilon \quad \text{and} \quad d_S((z, \xi(z)), (z_0, \nu_0)) < \delta \quad \text{for } z \in \tilde{U}.$$

By Definition 2.5, there exist functions $s_1(z, z')$, $s_2(z', z) > 0$, $z, z' \in \tilde{U}$, such that

$$\gamma_{z, \xi(z)}(s_1(z, z')) = \gamma_{z', \xi(z')}(s_2(z', z)), \quad s_1(z, z') + s_2(z', z) = t(z) + t(z').$$

By Lemma 2.2, these imply that

$$(19) \quad |t_0 - s_1(z, z')| < 2\varepsilon, \quad |t_0 - s_2(z', z)| < 2\varepsilon.$$

Consider a geodesic $\gamma(s) = \gamma_{z', \xi(z')}(s + s_2(z', z_0))$ for some fixed $z' \in \tilde{U}$, $z' \neq z_0$. It follows from (19) that Lemma 2.8 is applicable to the family $\mathcal{F}(z_0, t_0)$ and the geodesic γ with $r_1 = \tau_R(z_0, \nu_0) - 2\varepsilon$, $i_1 = 2\varepsilon$. Thus, $\gamma_{z', \xi(z')}$ and γ_{z_0, ν_0} intersect at $x_0 = \gamma_{z_0, \nu_0}(t_0)$. As $z' \in \tilde{U} \setminus \{z_0\}$ is arbitrary, all geodesics corresponding to family $\mathcal{F}(z_0, t_0)$ with a starting point $z' \in \tilde{U}$ intersect in x_0 . \square

Later on we will need the following modification of Lemma 2.8 which do not require that all geodesics of $\mathcal{F}(z_0, t_0)$ intersect γ near y_0 .

Lemma 2.9. *Let $z_0 \in \partial M$ and $\mathcal{F}(z_0, t_0) = \{U, \xi(\cdot), t(\cdot)\}$, $t_0 < \tau_M(z_0)$ be a family of focusing directions. Let $\gamma(\tau)$ be another geodesic in M which intersects all geodesics $\gamma_{z, \xi(z)}$ corresponding to $\mathcal{F}(z_0, t_0)$,*

$$\gamma_{z, \xi(z)}(r(z)) = \gamma(\tau(z)),$$

where $0 < r(z) \leq r_1 < \tau_M(z_0)$ and $|\tau(z)| \leq L$, where $L > 0$ is arbitrary. Assume, in addition, that $h(z) = r(z) + \tau(z)$ is continuous. Then $\gamma_{z, \xi(z)}(t(z)) = \gamma(h(z_0) - t_0)$ when z is sufficiently close to z_0 , i.e., all geodesics intersect at the same point.

Proof. We first show that there is only a finite number of intersections of $\gamma_{z_0, \nu_0}((0, r_1))$ with $\gamma([-L, L])$. Let $\tau_1, \dots, \tau_N \in [-L, L]$ and $r_0^1, \dots, r_0^N \in (0, r_1)$ define the points of the intersection,

$$\gamma_{z_0, \nu(z_0)}(r_0^j) = \gamma(\tau_j).$$

As all geodesics in balls of radius $\text{inj}(M)$ are shortest and $r_0^j \leq r_1$ with $\gamma_{z_0, \nu_0}([0, r_1])$ being the shortest between its endpoints,

$$N \leq \left\lceil \frac{2L}{\text{inj}(M)} \right\rceil + 1,$$

where $[t]$ denotes the integer part of $t \in \mathbb{R}$.

Let $0 < \varepsilon < \frac{1}{2}\text{inj}(M)$ and $U(\rho) = \partial M \cap B(z_0, \rho)$, where $B(z_0, \rho) \subset M$ is the ball with center z_0 and radius ρ . Then there is $\rho_0 > 0$ such that

$$\min_{1 \leq j \leq N} |r(z) - r_0^j| < \varepsilon, \quad \text{for } z \in U(\rho_0).$$

Indeed, otherwise there is a sequence $z_n \rightarrow z_0$ with $r(z_n) \rightarrow \tilde{r} < \tau_R(z_0, \nu(z_0))$ and $\tau(z_n) \rightarrow \tilde{\tau}$, $|\tilde{\tau}| \leq L$, such that

$$\gamma_{z_0, \nu_0}(\tilde{r}) = \gamma(\tilde{\tau}), \quad \tilde{r} \neq r_0^j, \quad j = 1, \dots, N,$$

which is a contradiction.

For $0 < \rho < \rho_0$, denote

$$V_j(\rho) = \{z \in U(\rho) : \gamma_{z, \xi(z)}(r) = \gamma(\tau), \quad r(z) + \tau(z) = h(z), \quad |r - r_0^j| \leq \varepsilon\}.$$

Sets $V_j(\rho)$ are relatively closed $U(\rho)$ and, therefore, measurable on ∂M . As $\bigcup_{j=1}^N V_j(\rho) = U(\rho)$, we see that for some j the set $V_j(\rho)$ has non-zero $(n-1)$ -dimensional measure. However, if $r_0^j \neq t_0$, the same considerations as in the proof of Lemma 2.8, by replacing r_0 by r_0^j and using a relatively open neighborhood $\tilde{U} \subset V_j(\rho)$ of z_0 , show that the set $V_j(\rho)$ has $(n-1)$ -dimensional measure equal to 0 when $\rho > 0$ is small enough. This shows that there are j and $\rho > 0$ such that $r_0^j = t_0$ and $U(\rho) \setminus V_j(\rho)$ has $(n-1)$ -dimensional measure equal to 0. Thus $V_j(\rho)$ is dense in $U(\rho)$. As $\varepsilon > 0$ is arbitrary, the continuity of the geodesic flow shows that $\gamma_{z_0, \xi_0}(t_0) = \gamma(h(z_0) - t_0)$. Together with Theorem 2.6 this completes the proof. \square

In the following we say that two geodesics $\mu(t)$ and $\tilde{\mu}(t)$ coincide if $\mu(t_1) = \tilde{\mu}(t_2)$ and $\mu'(t_1) = \pm \tilde{\mu}'(t_2)$ for some $t_1, t_2 \in \mathbb{R}$. Note that this is equivalent to $\mu(t) = \tilde{\mu}(a+t)$ or $\mu(t) = \tilde{\mu}(a-t)$ for all t in a non-empty open interval and $a \in \mathbb{R}$.

2.3. Reconstruction of the boundary cut locus distance.

Lemma 2.10. *The boundary, ∂M , and the broken scattering relation, R , determine the boundary cut locus distance $\tau_b(z)$, $z \in \partial M$.*

Proof. We recall that for $t_0 < \tau_b(z_0)$ the point z_0 is the unique point of ∂M closest to $x_0 = \gamma_{z_0, \nu_0}(t_0)$. On the contrary, when $t_0 > \tau_b(z_0)$ there is another point $w \in \partial M$ with $\text{dist}(\gamma_{z_0, \nu_0}(t_0), w) < t_0$. What is more, considerations in the beginning of Section 2.2 show the existence of a family $\mathcal{F}(z_0, t_0)$ of focusing directions for $t_0 < \tau_M(z_0)$. Recall that $\tau_b(z_0) < \tau_M(z_0)$.

Thus, when $\tau_b(z_0) < t_0 < \tau_M(z_0)$, there is a family $\mathcal{F}(z_0, t_0) = \{U, \xi(\cdot), t(\cdot)\}$ of focusing directions, a point $w \in \partial M$, $w \neq z_0$, and $s_0 < t_0$ such that

$$(20) \quad (z, \xi(z)) R_{t(z)+s_0}(w, \nu(w)), \quad z \in U.$$

Our next aim is to show that when $t_0 < \tau_b(z_0)$, there are no $w \in \partial M$ and $\mathcal{F}(z_0, t_0)$ satisfying (20) with $s_0 < t_0$.

Assuming the opposite, there is a neighborhood $U \subset \partial M$ of z_0 and a function $r(z)$ with

$$(21) \quad \gamma_{z, \xi(z)}(r(z)) = \gamma_{w, \nu(w)}(t(z) - r(z) + s_0), \quad z \in U.$$

Next we prove that

$$(22) \quad r_0 = \limsup_{z \rightarrow z_0} r(z) \leq t_0.$$

Assume that (22) is not true. Then there is a sequence $z_n \rightarrow z_0$ with $r(z_n) \rightarrow r_0 > t_0$. By the continuity of the exponential map, it follows from (21) that $\gamma_{z_0, \nu_0}(r_0) = \gamma_{w, \nu(w)}(t_0 - r_0 + s_0)$. Thus, by the triangle inequality,

$$\begin{aligned} & \text{dist}(w, \gamma_{z_0, \nu_0}(t_0)) \\ & \leq \text{dist}(w, \gamma_{w, \nu(w)}(t_0 - r_0 + s_0)) + \text{dist}(\gamma_{z_0, \nu_0}(r_0), \gamma_{z_0, \nu_0}(t_0)) \\ & \leq (t_0 - r_0 + s_0) + (r_0 - t_0) \leq s_0 < t_0, \end{aligned}$$

which contradicts the definition (3) of τ_b . Thus (22) is valid.

Therefore, by making U smaller if necessary, we have

$$r(z) < \tau_M(z_0), \quad z \in U.$$

Assume first that geodesics γ_{z_0, ν_0} and $\gamma_{w, \nu(w)}$ do not coincide. Applying Lemma 2.9 with $\gamma(\tau) = \gamma_{w, \nu(w)}(t_0 + s_0 - r_0 + \tau)$ and $L = 2t_0$, we obtain $\gamma_{z_0, \nu_0}(t_0) = \gamma_{w, \nu(w)}(s_0)$. As $s_0 < t_0$ this contradicts with the definition of τ_b . If γ_{z_0, ν_0} and $\gamma_{w, \nu(w)}$ coincide, condition $w \neq z_0$ implies that $\gamma_{z_0, \nu(z_0)}(t_0 + s_0) = w$. Then we would have $\text{dist}(x_0, \partial M) \leq \text{dist}(x_0, w) \leq s_0 < \tau_b(z_0)$, that is not possible.

Finally, by Lemma 2.4 the relation R determines the function $\mu_2(z)$ satisfying $\tau_b(z) \leq \mu_2(z)$. Let $J(z_0)$ be the set of those $t_0 \in [0, \mu_2(z_0)]$ for which there are $w \in \partial M$, $s_0 < t_0$, and $\mathcal{F}(z_0, t_0)$ satisfying (20). If $\tau_b(z_0) < \mu_2(z_0)$, we see that $(\tau_b(z_0), \mu_2(z_0)) \subset J(z_0)$. Thus we can determine $\tau_b(z_0)$ by setting $\tau_b(z_0) = \inf J(z_0)$ if $J(z_0) \neq \emptyset$ and $\tau_b(z_0) = \mu_2(z_0)$ otherwise. \square

2.4. Boundary distance representation of (M, g) . Next we construct of isometry type of manifold (M, g) by showing that the broken scattering relation, R , determines the boundary distance representation $\mathcal{R}(M)$ of (M, g) that is the set

$$\mathcal{R}(M) = \{r_x : x \in M\} \subset C(\partial M),$$

where $r_x : \partial M \rightarrow \mathbb{R}$ are the boundary distance functions

$$r_x(z) = \text{dist}(x, z), \quad z \in \partial M.$$

It is well-known, e.g. [5, 24, 25] that the set $\mathcal{R}(M)$ possesses a natural structure of a Riemannian manifold with the map

$$\mathcal{R} : M \rightarrow \mathcal{R}(M), \quad \mathcal{R}(x) = r_x(\cdot),$$

being an isomorphism. What is more, this metric structure can be identified just from the knowledge of the set $\mathcal{R}(M)$. An additional advantage of dealing with $\mathcal{R}(M)$ is the existence of a stable procedure to construct a metric approximation, in the Gromov-Hausdorff topology, to (M, g) given an approximation to $\mathcal{R}(M)$ in the Hausdorff topology on $L^\infty(\partial M)$, [23]. To construct $\mathcal{R}(M)$, we assume that the function τ_b is already known. We start with finding $\text{dist}_{\partial M}$ on ∂M which is inherited from (M, g) . We define that $\text{dist}_{\partial M}(z_1, z_2) = \infty$ when z_1 and z_2 lie on different components of ∂M .

Lemma 2.11. *The boundary, ∂M , and the broken scattering relation, R , determine, for any $z_1, z_2 \in \partial M$, the distance $\text{dist}_{\partial M}(z_1, z_2)$ along ∂M .*

Proof. It is enough to consider the case when z_1 and z_2 are in the same component of ∂M .

Using boundary normal coordinates, we see that there is $\varepsilon_0 > 0$ and $c_0 > 0$ such that

$$(23) \quad |\text{dist}(y_1, y_2) - \text{dist}_{\partial M}(y_1, y_2)| \leq c_0 \varepsilon^{3/2},$$

if $\text{dist}_{\partial M}(y_1, y_2) \leq \varepsilon^{3/4}$, $\varepsilon < \varepsilon_0$. Let $x_2 = \gamma_{y_2, \nu_2}(\varepsilon^{5/4})$. Making $\varepsilon_0 > 0$ smaller if necessary, we see that there is a unique shortest geodesic in M , γ_{y_1, ξ_1} , with $(y_1, \xi_1) \in \Omega_+$, from y_1 to x_2 . Moreover, using again boundary normal coordinates, we see that

$$(24) \quad |\text{dist}(y_1, x_2) + \text{dist}(x_2, y_2) - \text{dist}_{\partial M}(y_1, y_2)| \leq c_1 \varepsilon^{5/4}.$$

Let $\mu = \mu([0, l])$ be a shortest geodesic of ∂M from z_1 to z_2 . Let $N \in \mathbb{Z}_+$, $\varepsilon = l/N$ and $y_j = \mu(\varepsilon j)$, $j = 0, \dots, N$. Define $x_j = \gamma_{y_j, \nu_j}(\varepsilon^{5/4})$ and associate with each $j = 1, \dots, N$ a broken geodesic α_j which is the union of the geodesic from y_{j-1} to x_j and from x_j to y_j . Inequality (24) implies that if $N \rightarrow \infty$, then

$$(25) \quad |\text{dist}_{\partial M}(z_1, z_2) - \sum_{j=1}^N (\text{dist}(y_{j-1}, x_j) + \text{dist}(y_j, x_j))| \leq c_2 \varepsilon^{1/4} \rightarrow 0,$$

Motivated by this, define for $N \in \mathbb{Z}_+$ and $\varepsilon = 1/N$

$$d_N(z_1, z_2) = \inf \sum_{j=1}^N s_j,$$

where the infimum is taken over the points $y_j \in \partial M$, $j = 0, 1, \dots, N$, $y_0 = z_1, y_N = z_2$, which satisfy the following condition: For any $j = 0, \dots, N-1$, there are $\eta_j \in S_{y_j}M$, $(\nu_j, \eta_j)_g > 0$ and positive $s_j < \varepsilon^{3/4}$ such that

$$\left((y_j, \eta_j), (y_{j+1}, \nu(y_{j+1})), s_j \right) \in R, \quad j = 0, 1, \dots, N-1.$$

Using (23) we see that $d_N(z_1, z_2) \geq \text{dist}_{\partial M}(z_1, z_2) - c_3\varepsilon^{1/2}$. On the other hand, as we saw in (25), there are y_j, η_j , and s_j such that

$$|\text{dist}_{\partial M}(z_1, z_2) - d_N(z_1, z_2)| \leq c_4\varepsilon^{1/4} = cN^{-1/4} \rightarrow 0, \quad \text{when } N \rightarrow \infty.$$

Thus we get that

$$\text{dist}_{\partial M}(z_1, z_2) = \lim_{N \rightarrow \infty} d_N(z_1, z_2).$$

□

Next we determine the distance between boundary points with respect to the metric g in M .

Lemma 2.12. *The boundary, ∂M , and the broken scattering relation, R , determine the distance function $\text{dist}(x_1, x_2)$ for $x_1, x_2 \in \partial M$*

Proof. By [1], for any $x_1, x_2 \in \partial M$ a shortest path connecting them is a C^1 -path. Let $x(s)$, $s \in [0, l]$, $l = \text{dist}(x_1, x_2)$, $x(0) = x_1, x(l) = x_2$ be such a shortest path, parameterized by the arclength, that connects x_1 to x_2 in M . Moreover, by [1] it holds that if $x(s) \in M^{\text{int}}$ for $s \in (a, b)$, then $x((a, b))$ is a shortest geodesic between $x(a)$ and $x(b)$ in M .

Clearly, the set of $s \in [0, l]$ such that $x(s) \in M^{\text{int}}$ is open. By (23), for any $\varepsilon > 0$ there is a finite number points $a_i, i = 1, \dots, p$, $a_{p+1} = l$, and $b_i, i = 1, \dots, p$ with $0 \leq a_1 < b_1 \leq a_2 \cdots < b_p \leq a_{p+1} = l$ such that $z_i = x(a_i), y_i = x(b_i) \in \partial M$ and

$$(26) \quad \text{dist}(x_1, x_2) \leq \text{dist}_{\partial M}(x_1, z_1) + \left(\sum_{i=1}^p \text{dist}(z_i, y_i) + \text{dist}_{\partial M}(y_i, z_{i+1}) \right) \leq \text{dist}(x_1, x_2) + \varepsilon$$

and there are shortest paths $\gamma_{z_i, \eta_i}([0, l_i])$ in M of length $l_i = b_i - a_i$ from z_i to y_j that satisfy $\gamma_{z_i, \eta_i}((0, b_i - a_i)) \subset M^{\text{int}}$. Next we will relate (26) to the broken geodesic relation. Recall that relation R involved broken geodesics that start and end non-tangentially to the boundary. Because of this, we consider for tangential η_i the vector $\xi_i = (1 - h)^{1/2}\eta_i + h^{1/2}\nu(z_i) \in S_{z_j}M$. If η_i is non-tangential, we set $\xi_i = \eta_i$. When $h > 0$ is small enough and $s_i < l_i$ is sufficiently close to l_i ,

we have that $\gamma_{z_i, \xi_i}((0, s_i]) \subset M^{\text{int}}$, and the closest boundary point to $\gamma_{z_i, \xi_i}(s_i)$, denoted \tilde{y}_i , satisfies

$$\text{dist}(\gamma_{z_i, \xi_i}(s_i), \tilde{y}_i) < \frac{\varepsilon}{p}, \quad \text{dist}_{\partial M}(\tilde{y}_i, y_i) < \frac{\varepsilon}{p}.$$

Consider the broken geodesic from z_i to \tilde{y}_j which is the union of the geodesic from z_i to $\gamma_{z_i, \xi_i}(s_i)$ and from $\gamma_{z_i, \xi_i}(s_i)$ to \tilde{y}_j . It has the length $t_i \leq l_i + \varepsilon/p$ and non-tangential starting and ending directions. Thus $(z_i, \xi_i)R_{t_i}(\tilde{y}_i, \nu)$. These considerations show that

$$\text{dist}(x_1, x_2) = \inf \left(\text{dist}_{\partial M}(x_1, z_1) + \left(\sum_{i=1}^p t_i + \text{dist}_{\partial M}(\tilde{y}_i, z_{i+1}) \right) \right)$$

where the infimum is taken over $t_i > 0$, $z_i, \tilde{y}_i \in \partial M$, and directions ξ_i, ζ_i such that $z_{p+1} = x_2$ and the relations $(z_i, \xi_i)R_{t_i}(\tilde{y}_i, \zeta_i)$ are valid. \square

Theorem 2.13. *The boundary, ∂M , and the broken scattering relation, R , determine the set $\mathcal{R}(M) \subset C(\partial M)$.*

Proof. Let $\omega_{\partial M}$ be the boundary cut locus on M . As $M \setminus \omega_{\partial M}$ is dense in M , it is sufficient to find $\mathcal{R}(M \setminus \omega_{\partial M})$. Recall that, for $x_0 \in M \setminus \omega_{\partial M}$, we have $x_0 = \gamma_{z_0, \nu_0}(t_0)$, where $t_0 = \text{dist}(x_0, \partial M) < \tau_b(z_0)$ and z_0 is the unique boundary point closest to x_0 . Using the broken scattering relation R , we intend to determine, for any $w_0 \in \partial M$, $D(z_0, t_0, w_0) := \text{dist}(x_0, w_0)$.

Let $x(s)$ be a shortest path from x_0 to w_0 parametrized by the arclength. Denote by $w = x(s_0)$ the first point where $x(s)$ is in ∂M . Clearly,

$$(27) \quad \text{dist}(x_0, w_0) = s_0 + \text{dist}(w, w_0), \quad s_0 \geq t_0.$$

By [1], the path $x([0, s_0])$ is a geodesic in M . We denote $\eta = -x'(s_0)$ so that $x_0 = \gamma_{w, \eta}(s_0)$. As $t_0 \leq \tau_b(z_0) < \tau_M(z_0)$, there is a family of focusing directions $\mathcal{F}(z_0, t_0) = \{U, \xi(\cdot), t(\cdot)\}$ such that for $s_1 = s_0$, $w_1 = w$, and $\eta_1 = \eta$ we have

$$(28) \quad (w_1, \eta_1) R_{s_1+t(z)}(z, \xi(z)), \quad z \in U.$$

After these preparations we will show that

$$(29) \quad D(z_0, t_0, w_0) = \inf(\text{dist}(w_0, w_1) + s_1)$$

where infimum is taken over $w_1 \in \partial M$, $\eta_1 \in S_{w_1}M$, and $s_1 \geq t_0$ such that there is a focusing sequence $\mathcal{F}(z_0, t_0) = \{U, \xi(\cdot), t(\cdot)\}$ satisfying (28).

Formula (27) shows that the infimum on the right side of (29) is less or equal to $D(z_0, t_0, w_0)$. Thus to prove (29), it is enough to show that if w_1, η_1 , and s_1 satisfy (28) then $\rho = \text{dist}(w_0, w_1) + s_1 \geq \text{dist}(x_0, w_0)$.

Assume now that (28) is valid. Then, for some $r(z), \tau(z)$, $r(z) + \tau(z) = s_1 + t(z)$, we have that $\gamma_{z, \xi(z)}(r(z)) = \gamma(\tau(z))$.

Keeping aside the trivial case when the geodesics γ_{z_0, ν_0} and γ_{w_1, η_1} coincide, consider first the case when $\limsup r(z) = r > t_0$. Denoting $\gamma_{z_0, \nu_0}(r) = x_1$, we then have

$$\begin{aligned} \text{dist}(w_1, x_0) &\leq \text{dist}(w_1, x_1) + \text{dist}(x_1, x_0) \\ &\leq (s_1 + t_0 - r) + (r - t_0) \leq s_1, \end{aligned}$$

yielding $\rho \geq \text{dist}(w_0, w_1) + \text{dist}(w_1, x_0) \geq \text{dist}(w_0, x_0)$. If, however, $\limsup_{z \rightarrow z_0} r(z) = r \leq t_0$, we are in the situation of Lemma 2.9, which shows that

$$\gamma_{z_0, \nu_0}(t_0) = \gamma(s_1),$$

yielding again that $\rho \geq \text{dist}(w_0, x_0)$. \square

As the set $\mathcal{R}(M)$ can be naturally endowed with a differential structure and a Riemannian metric so that it becomes isometric to (M, g) , see e.g. [24, 25], we have finished the proof of Theorem 1.1. \square

3. PROOFS FOR THE RADIATIVE TRANSFER EQUATION.

3.1. Notations. Let X be a manifold with dimension n and $\Lambda_1 \subset T^*X \setminus 0$ be a Lagrangian submanifold. Let $(x_1, \dots, x_n) = (x', x'', x''')$ of be local coordinates X with $x' = (x_1, \dots, x_{d_1})$, $x'' = (x_{d_1+1}, \dots, x_{d_1+d_2})$, $x''' = (x_{d_1+d_2+1}, \dots, x_n)$, and $\phi(x, \theta)$, $\theta \in \mathbb{R}^N$ be a non-degenerate phase function that parametrizes Λ_1 . We say that distribution $u \in \mathcal{D}'(X)$ is a Lagrangian distribution associated with Λ_1 and denote $u \in I^m(X; \Lambda_1)$, if it can locally be represented as

$$u(x) = \int_{\mathbb{R}^N} e^{i\phi(x, \theta)} a(x, \theta) d\theta,$$

where $a(x, \theta) \in S^{m+n/4-N/2}(X \times \mathbb{R}^N \setminus 0)$, see [15, 19, 29].

Let $S_1 \subset X$ be a submanifold of codimension d_1 . We denote its conormal bundle by $N^*S = \{(x, \xi) \in T^*X \setminus 0 : x \in S, \xi \perp T_x S\}$. If $S_1 = \{x' = 0\}$ in local coordinates, $\Lambda_1 = N^*S_1$ and $u \in I^m(X; \Lambda_1)$, then locally

$$u(x) = \int_{\mathbb{R}^{d_1}} e^{ix' \cdot \theta'} a(x, \theta') d\theta', \quad a(x, \theta') \in S^\mu(X \times \mathbb{R}^{d_1} \setminus 0)$$

where $\mu = m - d_1/2 + n/4$. We denote $I^m(X; S_1) = I^\mu(X; N^*S_1)$ and say that $I^\mu(X; S_1)$ are the conormal distributions in space X associated with submanifold S_1 .

Also, we denote by $I^{p,l}(X; \Lambda_1, \Lambda_2)$ the distributions u in $\mathcal{D}'(X)$ associated to two cleanly intersecting Lagrangian manifolds $\Lambda_1, \Lambda_2 \subset T^*X$, see [15, 29]. Let S_1 and S_2 be submanifolds of M of codimensions d_1 and $d_1 + d_2$, $S_2 \subset S_1$. If in local coordinates $S_1 = \{x' = 0\}$,

$S_2 = \{x' = x'' = 0\}$, and $\Lambda_1 = N^*S_1$, $\Lambda_2 = N^*S_2$, then the distribution $u \in I^{p,l}(X; \Lambda_1, \Lambda_2)$ can be locally represented as

$$u(x) = \int_{\mathbb{R}^{d_1+d_2}} e^{i(x' \cdot \theta' + x'' \cdot \theta'')} a(x, \theta', \theta'') d\theta' d\theta'',$$

where $a(x, \theta', \theta'')$ belongs to a product type symbol class $S^{\mu', \mu''}(X \times (\mathbb{R}^{d_1} \setminus 0) \times \mathbb{R}^{d_2})$ containing symbols $a \in C^\infty$ that satisfy

$$|\partial_x^\gamma \partial_{\theta'}^\alpha \partial_{\theta''}^\beta a(x, \theta', \theta'')| \leq C_{\alpha\beta\gamma K} (1 + |\theta'| + |\theta''|)^{\mu - |\alpha|} (1 + |\theta''|)^{\mu' - |\beta|}$$

for all $x \in K$, multi-indexes α, β, γ , and compact sets $K \subset X$. Above, $\mu = p + l - d_1/2 + n/4$ and $\mu' = -l - d_2/2$.

By [15, 29], microlocally away from $\Lambda_1 \cap \Lambda_2$,

$$I^{p,l}(\Lambda_0, \Lambda_1) \subset I^{p+l}(\Lambda_0 \setminus \Lambda_1) \quad \text{and} \quad I^{p,l}(\Lambda_0, \Lambda_1) \subset I^p(\Lambda_1 \setminus \Lambda_0).$$

Thus the principal symbol of $u \in I^{p,l}(\Lambda_0, \Lambda_1)$ is well defined on $\Lambda_0 \setminus \Lambda_1$ and $\Lambda_1 \setminus \Lambda_0$.

3.2. Born series. In the sequel, we denote the distance on (N, g) by $d(x, y) = \text{dist}(x, y)$. Let $\gamma_{x,\xi}(t)$ be the geodesic on (N, g) with initial point x and initial direction $\xi \in S_{x_0}N$. Denote

$$\begin{aligned} \gamma_{x,\xi} &= \{\gamma_{x,\xi}(t) \in N : t \in \mathbb{R}\}, \\ \eta_{x,\xi} &= \{(\gamma_{x,\xi}(t), \dot{\gamma}_{x,\xi}(t)) \in SN : t \in \mathbb{R}\}, \\ \eta_{x,\xi}^+ &= \{(\gamma_{x,\xi}(t), \dot{\gamma}_{x,\xi}(t)) \in SN : t \in \mathbb{R}_+\}. \end{aligned}$$

The measurement operator A can be extended to distributions w supported in SU . In the following we consider u corresponding to $w_0(x, \xi) = \delta_{(x_0, \xi_0)}(x, \xi)$, $x_0 \in U$. We assume that $\gamma_{x_0, \xi_0}(\mathbb{R}_+)$ intersect the strictly convex manifold $M \subset N$. To analyze the corresponding solution, let us denote the specific geodesic on which the leading order singularities propagate by $\gamma_0 = \gamma_{x_0, \xi_0}$. Also, we denote the corresponding spray in SN by $\eta_0 = \eta_{x_0, \xi_0}$.

Let $u_0(x, \xi, t)$ be the solution of the equation (1) with S being zero, that is, $Hu_0 + \sigma u_0 = 0$, $u_0|_{t=0} = w_0$. Then $u_0(t) = c_0(x) \delta_{\eta_0(t)}(x, \xi)$, where $c_0(x)$ is a non-vanishing smooth function. To simplify notations, we consider the equation for all $t \in \mathbb{R}$, obtaining

$$u_0(t, x, \xi) = c_0(x) \delta_{\eta_0(t)}(x, \xi), \quad (t, x, \xi) \in \mathbb{R} \times SN.$$

In the following we analyze the higher order terms in the Born series, that is,

$$u_j = QSu_{j-1}, \quad j \geq 1,$$

where Q is defined by $v = QF$ where

$$Hv + \sigma v = F \quad \text{in } \mathbb{R}_+ \times SN, \quad v|_{t=0} = 0.$$

We note that there are $C_1, C_2 > 0$ so the solutions u^w of equation (1) satisfy

$$(30) \quad |u^w(x, \xi, t)| \leq C_1 e^{C_2 t} \|w\|_{L^\infty(SN)}.$$

To analyze the singularities of u , let us take the Laplace transform in time t and consider $\widehat{u}(k, x, \xi) = (u(\cdot, x, \xi))(k)$. By (30) the Laplace transform is well defined for $k \in \mathbb{C}$, $\operatorname{Re} k > C_2$. In the following, we consider k first as a parameter, and denote $\widehat{u}(x, \xi) = \widehat{u}(x, \xi, k)$. Then

$$(k + \widehat{H})\widehat{u} + \sigma\widehat{u} - S\widehat{u} = w_0 \quad \text{in } (x, \xi) \in SN,$$

where $w_0(x, \xi) = \delta_{(x_0, \xi_0)}(x, \xi)$ and

$$\widehat{H}u(x, \xi) = -\xi^j \frac{\partial u}{\partial x^j} - \xi^l \xi^j \Gamma_{lj}^m(x) \frac{\partial u}{\partial \xi^m}.$$

The operator $\widehat{H} + k : C^\infty(SN) \rightarrow C^\infty(SN)$ has \widehat{Q}_k a parametrix, see [19, 29], that satisfies $(QF)(k) = \widehat{Q}_k(F(k))$. Also, we denote $\widehat{u}(k) = \widehat{u}_0(k) + \widehat{u}_{sc}(k)$, where $\widehat{u}_{sc}(k) = \widehat{u}_1(k) + \widehat{u}_2(k) + \dots$

Consider now a Born iteration starting at a general $w_0(k)$. Since the coefficients of \widehat{H} are smooth functions and the kernel of S is a smooth compactly supported function, we that for any $s \geq 0$ there there is $C_3 = C_3(s) > 0$ such that for $\operatorname{Re} k > C_3$ the Born series

$$(31) \quad \widehat{w}(k) = \sum_{j=0}^{\infty} (\widehat{Q}_k S)^{j-1} w_0(k)$$

converges in Sobolev space $H_{loc}^s(SN)$ when $w_0(k) \in H_{loc}^s(SN)$.

3.3. Properties of the compositions of the operators S and \widehat{Q}_k .

Lemma 3.1. *We can write $S = S_1 S_2$,*

$$S_j f(x, \xi) = \int_{S^{n-1}} K_j(x, \xi, \xi') f(x, \xi') dS(\xi'), \quad j = 1, 2$$

where $K_j(x, \xi, \xi') \in C_0^\infty(SN \times SN)$.

Proof. Interpreting x as a parameter, we define $K_x : L^2(S^{n-1}) \rightarrow L^2(S^{n-1})$ by

$$K_x f(\xi) = \int_{S^{n-1}} K(x, \xi, \xi') f(\xi') dS(\xi').$$

As the kernel $K(x, \xi, \xi')$ is smooth, we see that for all $\alpha \in \mathbb{N}^n$ and $l, m \in \mathbb{N}$ there is a constant $c_{\alpha lm}$ such that

$$(32) \quad \sup_{x \in M} \|\partial_x^\alpha (1 - \Delta_\xi)^m K(x, \xi, \xi')\|_{C^l(S^{n-1} \times S^{n-1})} < c_{\alpha lm},$$

where Δ_ξ is the Laplace-Beltrami operator of the $(n-1)$ -sphere S^{n-1} . Let $a_m > 0$ be numbers such that $0 < a_m < e^{-m} \min(1, c_{\alpha lm}^{-1})$ for all

$\max(|\alpha|, l) \leq m$. Then the operator

$$B = \sum_{m=0}^{\infty} a_m (1 - \Delta_{\xi})^m$$

defines an unbounded non-negative selfadjoint operator $B : L^2(S^{n-1}) \rightarrow L^2(S^{n-1})$ having an inverse $J = B^{-1}$ that can be extended to a smoothing operator $\mathcal{D}'(S^{n-1}) \rightarrow C^{\infty}(S^{n-1})$. Moreover, by (32) we see that for any x the operator $L_x = BK_x$ defines a smoothing operator $\mathcal{D}'(S^{n-1}) \rightarrow C^{\infty}(S^{n-1})$ and its Schwartz kernel $L_x(\xi, \xi')$ is a C^{∞} -smooth in all variables (x, ξ, ξ') . Thus we prove the assertion by defining $K_2(x, \xi, \xi') = L_x(\xi, \xi')$ and $K_1(x, \xi, \xi') = J(\xi, \xi')$, where $J(\xi, \xi')$ is the Schwartz kernel of J . \square

The Born series iteration can be written as

$$\widehat{u}_j(k) = \widehat{Q}_k S_1 A^{j-1} S_2 \widehat{u}_0(k)$$

where $A = S_2 \widehat{Q}_k S_1$. To analyze the operator A we consider first the case where $K(x, \xi, \xi')$ would be the constant 1. Denote by S^c the operator corresponding to a constant scattering kernel $K(x, \xi, \xi') = 1$. For this purpose, we introduce operators $T = \pi_* : L^2(SN) \rightarrow L^2(N)$ and $T^* = \pi^* : L^2(N) \rightarrow L^2(SN)$, that is,

$$Tu(x) = c_n^{-1} \int_{S_x N} u(x, \xi) dV_g(\xi), \quad T^*v(x, \xi) = v(x),$$

where $c_n = \text{vol}(S^{n-1})$ and V_g is the volume on $S_x N$.

Lemma 3.2. *Let $Z = SN \times SN$, $L_0 = \{(x, \xi, y, \eta) \in Z : x = y\}$, and $\Sigma_0 = N^*L_0$. The Schwartz kernels of A^c and A satisfy*

$$(33) \quad A^c(x, \xi, y, \eta) \in I^{-1}(Z; L_0) = I^r(Z; \Sigma_0),$$

$$(34) \quad A(x, \xi, y, \eta) \in I^{\rho}(Z; \Sigma_0)$$

where $r = -(n+1)/2$, $\rho = r + \varepsilon$, and $\varepsilon > 0$.

Proof. Clearly, $TT^* = I$ and $S^c = T^*T$. Thus we have $S^c = S_1^c S_2^c$ where $S_1^c = S_2^c = S$. In the local coordinates S^c has the Schwartz kernel

$$S^c(x, \xi, x', \xi') = \delta(x - x') \in I^0(Z; L_0) = I^{m_1}(Z; \Sigma_0),$$

where $m_1 = (1-n)/2$. To analyze $A = S_2 \widehat{Q}_k S_1$, we first consider the operator

$$A^c = S_2^c \widehat{Q}_k S_1^c = T^* T \widehat{Q}_k T^* T.$$

Denote $\widetilde{Q}_k = T \widehat{Q}_k T^* : L^2(N) \rightarrow L^2(N)$ and let $v \in C_0^{\infty}(N)$. Then

$$(\widehat{Q}_k T^* v)(x, \xi) = \int_{-\infty}^0 h(x, \xi, s, k) v(\gamma_{x, \xi}(s)) ds$$

where $h(s, x, \xi, k)$ is the solution of the differential equation

$$(35) \quad \begin{aligned} \partial_s h(s, x, \xi, k) + (k + \sigma(\gamma_{x,\xi}(s)))h(s, x, \xi, k) &= 0, \\ h(s, x, \xi, k)|_{s=0} &= 1. \end{aligned}$$

Note that

$$(36) \quad h(x, \xi, s, k) = e^{-ks}h(x, \xi, s, 0).$$

Thus, using the assumption that the manifold N is simple, we have

$$(37) \quad \begin{aligned} (T\widehat{Q}_k T^*v)(x) &= \int_{S^{n-1}} \int_{-\infty}^0 h(s, x, \xi, k)v(\gamma_{x,\xi}(s)) ds dV_g(\xi) \\ &= \int_N [h(s(x, y), x, \xi(x, y), k)j(x, y)]v(y) dV_g(y), \end{aligned}$$

where $s(x, y) \in (-\infty, 0]$ and $\xi(x, y) \in S_x N$ are defined by $\exp_x^{-1}(y) = s(x, y)\xi(x, y)$, and $j(x, y) = \det(d\exp_x|_y)^{-1}$ is the Jacobian determinant where $d\exp_x|_y$ is the differential of the map \exp_x evaluated at y . Since (N, g) is simple, the kernel $b(x, y) := h(s(x, y), x, \xi(x, y), k)j(x, y)$ is smooth outside the diagonal and behaves near the diagonal as

$$b(x, y) \sim e^{-kd(x,y)}d(x, y)^{1-n}.$$

Using (37) we see that \widetilde{Q}_k is a pseudodifferential operator of order (-1) (for a similar argument see [37]).

The Schwartz kernel $\widetilde{Q}_k(x, x') \in I^{-1}(N \times N; \text{diag}(N \times N))$ of \widetilde{Q} can be written as

$$\widetilde{Q}_k(x, x') = \int_{\mathbb{R}^n} e^{i(x-x') \cdot \theta} a(x, x', \theta) d\theta, \quad a \in S^{-1}(N \times N \times \mathbb{R}^n \setminus 0).$$

The same expression defines a function $\widetilde{Q}_k(x, \xi, x', \xi') := \widetilde{Q}_k(x, x') \in I^{-1}(SN \times SN; L_0)$. This function is the Schwartz kernel of $A^c = T^*\widetilde{Q}_k T$ and thus we see that the first part of the assertion, the formula (33) is satisfied.

Next we consider the Schwartz kernel of A , that is, $A(x, \xi, y, \eta)$. It can be written as a product

$$A(x, \xi, y, \eta) = A^c(x, \xi, y, \eta)J(x, \xi, y, \eta)$$

where (using the Riemannian normal coordinates at x)

$$J(x, \xi, y, \eta) = K_2(x, \xi, \frac{y-x}{|y-x|})K_1(y, \frac{x-y}{|x-y|}, \eta).$$

Now $J_1(x, y, z) := K_1(x, \xi, z/|z|)$ and $J_2(x, y, z) := K_2(x, z/|z|, \xi)$ are homogeneous functions of degree zero in z , and we see that [15, formula (1.2)]

$$K_2(x, \xi, \frac{y-x}{|y-x|}), K_1(y, \frac{x-y}{|x-y|}, \eta) \in I^{-n}(Z; L_0).$$

Now we can write A as the product of K_1 , K_2 , and A^c . To analyze this product, we need the following lemma extending results of [15] for less regular conormal distributions.

Lemma 3.3. *Let Z be a manifold of dimension d and L_0 be a submanifold with codimension n . Assume that $A \in I^{-d}(Z; L_0)$ and $B \in I^\mu(Z; L_0)$, $\mu < 0$. Then the pointwise product $AB \in I^{\mu+\varepsilon}(Z; L_0)$ for any $\varepsilon > 0$.*

Proof. Let (z', z'') be local coordinates of X such that $L_0 = \{z' = 0\}$. Then

$$A(z) = \int_{\mathbb{R}^d} e^{iz' \cdot \theta} a(z, \theta) d\theta, \quad B(z) = \int_{\mathbb{R}^d} e^{iz' \cdot \theta} b(z, \theta) d\theta,$$

where $a(z, \theta) \in S^{-d}(X \times \mathbb{R}^d \setminus 0)$ and $b(z, \theta) \in S^\mu(X \times \mathbb{R}^d \setminus 0)$. The symbol $c(z, \theta)$ of the product $A(z)B(z)$ is given by the convolution

$$c(z, \theta) = \int_{\mathbb{R}^d} a(z, \theta - \tilde{\theta}) b(z, \tilde{\theta}) d\tilde{\theta},$$

and a simple computations shows that

$$|c(z, \theta)| \leq C \int_{\mathbb{R}^d} (1 + |\theta - \tilde{\theta}|)^\mu (1 + |\tilde{\theta}|)^{-d} d\tilde{\theta} \leq C'(1 + |\theta|)^{\mu+\varepsilon},$$

with $\varepsilon > 0$. Indeed, decomposing the domain of integration as $\mathbb{R}^d = B(0, \frac{1}{2}|\theta|) \cup B(\theta, \frac{1}{2}|\theta|) \cup (\mathbb{R}^d \setminus (B(0, \frac{1}{2}|\theta|) \cup B(\theta, \frac{1}{2}|\theta|)))$, we see that

$$\begin{aligned} |c(z, \theta)| &\leq C_1 |\theta|^\mu \log |\theta| + C_2 |\theta|^{-d} |\theta|^{d+\mu} (1 + \delta_{\mu, -d} \log |\theta|) + C_3 |\theta|^\mu \\ &\leq C'(1 + |\theta|)^{\mu+\varepsilon}, \end{aligned}$$

where $|\theta| > 1$ and $\delta_{\mu, -d}$ is one if $\mu = -d$ and zero otherwise. The derivatives of $c(z, \theta)$ can be estimated in similar way, and we obtain that $c(z, \theta) \in S^{\mu+\varepsilon}(X \times \mathbb{R}^d \setminus 0)$. \square

Lemma 3.3 for the product of K_1 , K_2 , and A^c implies (34). This proves Lemma 3.2. \square

The previous result says, roughly speaking, that A is like a Ψ DO of order (-1) operating in (x, y) -variables when ξ and η are considered as parameters.

Next we consider powers of A . Next, Σ'_0 denotes the canonical relation corresponding to the Lagrangian manifold Σ_0 . We see that $\Sigma'_0 \times \Sigma'_0$ intersects cleanly $T^*SN \times \text{diag}(T^*SN \times T^*SN) \times T^*SN$ with the excess $d = (n - 1)$. Thus using [42, Thm VIII.5.2], we see that

$$A^2 = A \circ A \in I^{-2\rho+d/2}(Z; \Sigma_0) = I^{\rho_2}(Z; \Sigma_0),$$

where $\rho_2 = -(n + 3)/2 + 2\varepsilon$ with any $\varepsilon > 0$. Iterating operator A , we see that

$$A^j \in I^{\rho_j}(Z; \Sigma_0) = I^{-1-j+\varepsilon}(Z; L_0), \quad \rho_j = -\frac{n+1}{2} - j + \varepsilon, \quad \varepsilon > 0.$$

3.4. Singularities of the terms in the Born series. In the following, let $\Lambda_0 = N^*Y_0$ and $\Lambda_1 = N^*(Y_1)$, where

$$\begin{aligned} Y_0 &= \{(\gamma_0(t), \dot{\gamma}_0(t)) \in SN : t \in \mathbb{R}\}, \\ Y_1 &= S(\gamma_0) = \{(x, \xi) \in SN : x \in \gamma_0(\mathbb{R})\}. \end{aligned}$$

Moreover, let $P = P(x, \xi, D_x, D_\xi) = \widehat{H} + k$,

$$\text{char}(P) = \{(x, \xi, \tilde{x}, \tilde{\xi}) \in T^*(SN) : \xi^i \tilde{x}_i + \xi^i \xi^j \Gamma_{ij}^k(x) \tilde{\xi}_k = 0\},$$

and let $\Xi(x, \xi, \tilde{x}, \tilde{\xi})$ be the bicharacteristic of $P(x, \xi, D_x, D_\xi)$ (i.e. integral curve of the Hamilton vector field in $T^*(SN) \setminus 0$) starting from $(x, \xi, \tilde{x}, \tilde{\xi}) \in T^*(SN)$. Then the flow-out canonical relation generated by $\text{char}(P)$ is

$$\begin{aligned} \Lambda'_P &= \{(x, \xi, \tilde{x}, \tilde{\xi}; y, \zeta, \tilde{y}, \tilde{\zeta}) \in (T^*(SN) \setminus 0) \times (T^*(SN) \setminus 0) : \\ &\quad (x, \xi, \tilde{x}, \tilde{\xi}) \in \text{char}(P), \quad (y, \zeta, \tilde{y}, \tilde{\zeta}) \in \Xi(x, \xi, \tilde{x}, \tilde{\xi})\}. \end{aligned}$$

The flow-out of Λ_1 in $\text{char}(P)$ is the Lagrangian manifold $\Lambda_2 \subset T^S N \setminus 0$ satisfying $\Lambda'_2 = \Lambda'_P \circ \Lambda'_0$.

Lemma 3.4. *We have*

$$\widehat{u}_0(x, \xi, k) = c_0(x, k) \delta_{\eta_0}(x, \xi) \in I^{r_0}(SN; \Lambda_0),$$

where $c_0(x, k)$ is a smooth non-vanishing function and $r_0 = (2n - 3)/4$. For $j \geq 1$,

$$(38) \quad \widehat{u}_j(k) \in I^{r_j, -\frac{1}{2}}(SN; \Lambda_1, \Lambda_2), \quad r_j = -\frac{n}{2} - j + \varepsilon \delta_{j \geq 2}, \quad \varepsilon > 0,$$

where $\delta_{j \geq 2}$ is one if $j \geq 2$ and zero otherwise.

Proof. For the zeroth term in the Born series the claim is true by definition. Next we analyze the higher order terms. Clearly,

$$S_2 \widehat{u}_0(x, \xi, k) = K_2(x, \xi, \eta(x))(S^c \widehat{u}_0)(x, \xi, k),$$

where $\eta(x) \in S_x N$ defines a smooth vector field such that if $x = \gamma_0(s)$ then $\eta(x) = \dot{\gamma}_0(s)$. A simple computation shows that $\Lambda'_0 \times \Sigma'_0$ intersects $\text{diag}(T^*SN \times T^*SN) \times (T^*SN)$ transversally. Now $S_2 \in I^0(SN \times SN; L_0) = I^{m_1}(SN \times SN; \Sigma_0)$, where $m_1 = (1 - n)/2$ and by [19, Thm 25.2.3] that S_2 can be considered as a continuous operator

$$S_2 : I^{r_0}(SN; \Lambda_0) \rightarrow I^s(SN; \Lambda_1),$$

where $s = r_0 + m_1$ and $\Lambda'_1 = \Lambda'_0 \circ \Sigma'_0$. A simple computation shows that $\Lambda'_1 \circ \Sigma'_0 = \Lambda'_1$, and that $\Lambda'_1 \times \Sigma'_0$ intersects $\text{diag}(T^*SN \times T^*SN) \times (T^*SN)$ cleanly with excess $e = (n - 1)$. Thus we have by [19, Thm 25.2.3] that

$$A^j S_2 \widehat{u}_0(k) \in I^{\rho_j + m_1 + e/2}(SN; \Lambda_1).$$

Again, as $\Lambda'_1 \circ \Sigma'_0 = \Lambda'_1$, and $\Lambda'_1 \times \Sigma'_0$ intersects $\text{diag}(T^*SN \times T^*SN) \times (T^*SN)$ cleanly with excess e , we see that since $S_1 \in I^{m_1}(Z; \Sigma_0)$,

$$(39) \quad S_1 A^j S_2 \widehat{u}_0(k) \in I^{\rho_j + 2(m_1 + e/2)}(SN; \Lambda_1) = I^{\rho_j}(SN; \Lambda_1).$$

To analyze $\widehat{u}_j(k) = \widehat{Q}_k S_1 A^{j-1} S_2 \widehat{u}_0(k)$, we observe that the operator $P = \widehat{H} + ik$ is a first order operator of real principal type. As \widehat{Q}_k is its parametrix, it follows from [29] that the Schwartz kernel

$$(40) \quad \widehat{Q}_k \in I^{\frac{1}{2}-1, -\frac{1}{2}}(Z; \Delta_{T^*Z}, \Lambda_P),$$

where Δ'_{T^*Z} is the diagonal of $T^*Z \times T^*Z$ and $\Lambda'_P \subset T^*(Z)$ is the flow-out canonical relation generated by $\text{char}(P)$. Now N^*Y_1 intersects $\text{char}(P)$ transversally. Hence we obtain (38) by [15, Prop. 2.1]. \square

3.5. Principal symbol of the singularity. For any $s > 0$ there is j_0 such that $\widehat{u}_{j_0}(k) \in H_{loc}^s(SN)$. Using the convergence of the Born series (31), we see that the series $\widehat{u}_{j_0}(k) + \widehat{u}_{j_0+1}(k) + \widehat{u}_{j_0+2}(k) + \dots$ converges in $H_{loc}^s(SN)$.

Next we consider how to find the geodesic γ_0 in U . To this end we observe using (39) that $T\widehat{u}(k) = T\widehat{u}_0(k) + T\widehat{u}_{sc}(k) \in I^0(N; \gamma_0)$ and $T\widehat{u}_0(k) \in I^0(N; \gamma_0)$ have the same non-vanishing principal symbol. Thus $T\widehat{u}(k)$ in U determines $U \cap \gamma_0$.

Moreover, the above convergence of the Born series in Sobolev spaces and (38) yield that $\widehat{u}_1(k)$ and $\widehat{u}_{sc}(k) = \widehat{u}_1(k) + \widehat{u}_2(k) + \dots$ are both elements in $I^{r_1, -\frac{1}{2}}(SN; \Lambda_1, \Lambda_2)$ and they have the same principal symbol on $\Lambda_2 \setminus \Lambda_1$. Motivated by this, we consider next $\widehat{u}_1(k)$.

Using the above notations, we see that

$$S\widehat{u}_0(x, \xi, k) = S(x, \xi, \eta(x))h(d(x, x_0), x_0, \xi_0, k)c_1(x)\delta_{\gamma_0}(x) \in I^0(SN; Y_1),$$

where $c_1(x)$ is a smooth non-vanishing function. Moreover, the operator \widehat{Q}_k has the Schwartz kernel (40) that away from the diagonal has the form

$$\widehat{Q}_k(x, \xi, x', \xi') = h(d(x, x'), x', \xi', k)\delta_{\eta_{x', \xi'}}^+(x, \xi),$$

where h is defined in (35). Thus, in $(x, \xi, x', \xi') \in Z \setminus L_0$, the kernel of \widehat{Q}_k has the form

$$\widehat{Q}_k(x, \xi, x', \xi') = \int_{\mathbb{R}^N} e^{i\psi(x, \xi, x', \xi', \theta)} [h(d(x, x'), x', \xi', k)q(x, \xi, \theta)] d\theta \quad \text{mod } C^\infty(Z)$$

where $\psi(x, \xi, x', \xi', \theta)$ is a non-degenerate phase function parameterizing the Lagrangian Λ_P and $q(x, \xi, \theta) \in S^{r_1-1/2+(4n-2)/4-N/2}(\mathbb{R}^n \times \mathbb{R}^{n-1} \times \mathbb{R}^N \setminus 0)$ has a non-vanishing principal symbol.

Let us use in $SN \setminus \eta_0$ local coordinates $\mathcal{S} : (x, \xi) \mapsto (s_j(x, \xi))_{j=1}^{2n-1}$ having the property that if $\gamma_{x, \xi}(\mathbb{R}_-)$ intersects the geodesic $\gamma_0(\mathbb{R}_+)$ then $s_1 = s_1(x, \xi)$ is the unique value such that

$$\gamma_{x, \xi}(\mathbb{R}_-) \cap \gamma_0(\mathbb{R}_+) = \gamma_0(s_1),$$

and $s_2(x, \xi) = d(\gamma_0(s_1(x, \xi)), x)$. By [15, Prop. 2.1],

$$\widehat{u}_1(k) = \widehat{Q}_k S\widehat{u}_0(k) \in I^{r_1, -\frac{1}{2}}(SN; \Lambda_1, \Lambda_2)$$

and $\widehat{u}_1(x, \xi, k)$ in $(x, \xi) \in SN \setminus \eta_0$ has in the above local coordinates the form

$$\widehat{u}_1(x, \xi, k) = \int_{\mathbb{R}^N} e^{i\phi(x, \xi, \theta)} [a(x, \xi, k)p(x, \xi, \theta)] d\theta \quad \text{mod } C^\infty(SN),$$

$$a(x, \xi, k) = h(s_1(x, \xi), x_0, \xi_0, k) h(s_2(x, \xi), \gamma_0(s_1(x, \xi)), \zeta(x, \xi), k)$$

where $\phi(x, \xi, \theta)$ is a non-generate phase function parametrizing the Lagrangian manifold Λ_2 , $\zeta(x, \xi) = -\dot{\gamma}_{x, \xi}(-s_2(x, \xi))$ is the direction of $\gamma_0(s_1)$ and $p(x, \xi, \theta)$ is a symbol with a non-vanishing principal symbol. Note that on $\Lambda_2 \setminus \Lambda_1$ the principal symbol of $a(x, \xi, k)p(x, \xi, \theta)$ is non-vanishing on the conormal bundle of the submanifold

$$K = \{(x, \xi) \in SN : \gamma_{x, \xi}(\mathbb{R}_-) \cap \gamma_0(\mathbb{R}_+) \cap M^{\text{int}} \neq \emptyset\}.$$

By (36),

$$(41) \quad a(x, \xi, k) = e^{-k(s_1+s_2)} S(\gamma_0(s_1), \zeta, \dot{\gamma}_0(s_1)) b_0(x, \xi),$$

where $s_1 = s_1(x, \xi)$, $s_2 = s_2(x, \xi)$, $\zeta = \zeta(x, \xi)$, and $b_0(x, \xi)$ is non-vanishing and independent of k .

Now we are ready prove unique solvability of the inverse problem.

Proof of Theorem 1.2. First we note that have found already the set $\gamma_0 \cap U$. Thus we know the set $W := SN \setminus (SM \cup \eta_0)$. By observing the singularities of $\widehat{u}(k)$ at W , we can find the conormal bundle of the manifold $K \cap U$. Thus by observing $\widehat{u}(k)$ at W we can find all points $(x, \xi) \in W$ such that there is a broken geodesic from (x_0, ξ_0) to (x, ξ) with a breaking point in M^{int} . Moreover, we can find the principal symbol of $\widehat{u}(k)$ on $N^*K \cap W$ in some local coordinates. By (41), observing the asymptotics of the principal symbol on $N^*K \cap W$ when $k \rightarrow \infty$, we can find the function $d(x_0, \gamma_0(s_1)) + d(\gamma_0(s_1), x)$, $s_1 = s_1(x, \xi)$ on $(x, \xi) \in W$. Here $\gamma_0(s_1) \in M^{\text{int}}$ is the point at which the broken geodesic from (x_0, ξ_0) to (x, ξ) breaks, that is, the broken geodesic changes its direction.

Using the continuity of the geodesic flow, we can find all $(x, \xi) \in SN \setminus SM$ that are in the broken scattering relation with (x_0, ξ_0) and moreover, in such case we can find the broken geodesic distance $d(x_0, \gamma_0(s_1)) + d(\gamma_0(s_1), x)$. This proves the result and even more: The singularities of the Schwartz kernel of the operator A determine the broken scattering relation R . \square

Acknowledgements: M. Lassas was partially supported by the Academy of Finland Center of Excellence programme 213476. G. Uhlmann was partially supported by FRG grant DMS 0554575 and a Walker Family Endowed Professorship.

REFERENCES

- [1] Alexander R., Alexander S. Geodesics in Riemannian manifolds-with-boundary. *Indiana Univ. Math. J.* **30** (1981), 481–488.

- [2] Alexandrova, I., Structure of the semi-classical amplitude for general scattering relations, *Comm. PDE* **30** (2005), 1505–1535.
- [3] Alexandrova, I., Structure of the short range amplitude for general scattering relations, to appear in *Asymptotic Analysis*.
- [4] Ambrose, W. Parallel translation of Riemannian curvature. *Ann. of Math.* **64** (1956), 337–363.
- [5] Anderson M., Katsuda A., Kurylev Y., Lassas M., Taylor M. Boundary regularity for the Ricci equation, geometric convergence, and Gel'fand inverse boundary problem *Invent. Math.*, **105** (2004), 261–321.
- [6] Arridge, S. Optical tomography in medical imaging. *Inverse Problems* **15** (1999), R41–93
- [7] Arridge, S. Diffusion tomography in dense media *Scattering: Scattering and Inverse Scattering in Pure and Applied Science* Vol 1. Ed. R. Pike and P. Sabatier, 2002, 920–36.
- [8] Bal, G. Optical tomography for small volume absorbing inclusions. *Inverse Problems* **19** (2003), 371–386.
- [9] Belishev M. and Kurylev Y. To the reconstruction of a Riemannian manifold via its spectral data (BC-method), *Comm. PDE*, **17** (1992), 767–804.
- [10] Choulli, M., Stefanov, P. Reconstruction of the coefficients of the stationary transport equation from boundary measurements. *Inverse Problems* **12** (1996), L19–L23.
- [11] Choulli, M., Stefanov, P. Inverse scattering and inverse boundary value problems for the linear Boltzmann equation. *Comm. PDE* **21** (1996), 763–785.
- [12] Croke C. Rigidity for surfaces of non-positive curvature. *Comment. Math. Helv.*, **65** (1990), 150–169.
- [13] Croke C. Rigidity and the distance between boundary points. *J. Diff. Geometry*, **33** (1991), 445–464.
- [14] Gromov M. Filling Riemannian manifolds. *J. Differential Geometry*, **18** (1983), 1–148.
- [15] Greenleaf, A., Uhlmann, G. Recovering singularities of a potential from singularities of scattering data. *Comm. Math. Phys.* **157** (1993), 549–572.
- [16] Guillemin, V., Sojourn times and asymptotic properties of the scattering matrix. *Publ. Res. Inst. Math. Sci.* **12**(1976/77), supplement, 69–88.
- [17] Ferwerda, H. The radiative transfer equation for scattering media with a spatially varying refractive index. *J. Opt. A: Pure Appl. Opt.* **1**(1999), :L1–L2.
- [18] He, S., Zhang, H., Romanov, V. Explicit identification of multiple small breast cancers in an optical mammographic imaging. *Inverse Problems* **18** (2002), 1555–1567.
- [19] Hörmander, L. *The analysis of linear partial differential operators*, vol. 4., Springer 1985.
- [20] Heino, J., Somersalo, E. Estimation of optical absorption in anisotropic background. *Inverse Problems* **18** (2002), 559–73.
- [21] Hyvönen, N. Analysis of optical tomography with non-scattering regions *Proc. Edinburgh Math. Soc.* **45**(2002), 257–76.
- [22] Hyvönen, N. Characterizing inclusions in optical tomography. *Inverse Problems* **20** (2004), 737–751.
- [23] Katsuda, A., Kurylev, Y., Lassas, M. Stable construction of a Riemannian manifold from it boundary distance functions, *Inverse Problems and Imaging* **1** (2007), 135–157.
- [24] Katchalov A., Kurylev Y., Lassas M. *Inverse Boundary Spectral Problems*, Chapman/CRC, Boca Raton (2001), xi+290 pp.

- [25] Kurylev Y. Multidimensional Gel'fand inverse problem and boundary distance map, in: *Inverse Problems related with Geometry*, Ibaraki Univ. (1997), 1-16.
- [26] Klingenberg, W. *Riemannian geometry*. Walter de Gruyter, 1995. x+409 pp.
- [27] Lassas, M., Sharafutdinov, V., Uhlmann, G. Semi-global boundary rigidity for Riemannian metrics. *Math. Ann.* **325** (2003), 767–793.
- [28] McDowall, S. Optical tomography on simple Riemannian surfaces. *Comm. PDE* **30** (2005), 1379–1400.
- [29] Melrose, R.; Uhlmann, G. Lagrangian intersection and the Cauchy problem. *Comm. Pure Appl. Math.* **32** (1979), 483–519.
- [30] Michel, R. Sur la rigidité imposée par la longueur des géodésiques. *Invent. Math.* **65** (1981), 71–84.
- [31] Michel R. Restriction de la distance géodésique à un arc et rigidité. *Bull. Soc. Math. France*, **122** (1994), 435–442.
- [32] Mukhometov R. On a problem of reconstructing Riemannian metrics. *Siberian Math. J.*, **22** (1982), 420–433.
- [33] Otal J.-P. Sur les longueurs des géodésiques d'une métrique à courbure négative dans le disque. *Comm. Math. Helv.* **65** (1990), 334–347.
- [34] Pestov, L., Uhlmann, G. Two dimensional compact simple Riemannian manifolds are boundary distance rigid. *Ann. of Math.* **161** (2005), 1093–1110.
- [35] L. Pestov and G. Uhlmann. The scattering relation and the Dirichlet-to-Neumann map, *Contemporary Math*, **412** (2006), 249-262.
- [36] Sakai T. *Riemannian Geometry*. Trans. Math. Monogr., **149**, AMS, 1995.
- [37] Stefanov P., Uhlmann G. Stability estimates for the X-ray transform of tensor fields and boundary rigidity, *Duke Math. J.* **123** (2004), 445–467.
- [38] Stefanov P., Uhlmann G. Boundary rigidity and stability for generic simple metrics, *Journal Amer. Math. Soc.* **18** (2005), 975–1003
- [39] Stefanov P., Uhlmann G. Boundary and Lens Rigidity, Tensor Tomography, and Analytic Microlocal Analysis, to appear Springer-Verlag, Tokyo.
- [40] Stefanov P., Uhlmann G. Optical tomography in two dimensions, *Methods and Applications of Analysis* **10** (2003), 445–467.
- [41] Uhlmann G. Inverse boundary value problems for partial differential equations. *Proceedings of the International Congress of Mathematicians*. Vol. III (Berlin, 1998). Doc. Math. Vol. III, 77–86.
- [42] Treves, F. *Introduction to pseudodifferential and Fourier integral operators* *Fourier integral operators.*, Vol. 2. Plenum Press., 1980. xiv+301–649 pp.

YAROSLAV KURYLEV, UNIVERSITY OF LOUGHBOROUGH DEPARTMENT OF MATHEMATICAL SCIENCES, LOUGHBOROUGH, LEICESTERSHIRE, LE11 3TU, UK

MATTI LASSAS, HELSINKI UNIVERSITY OF TECHNOLOGY, INSTITUTE OF MATHEMATICS, PO BOX 1100, FIN-02015 TKK, FINLAND

GUNTHER UHLMANN, UNIVERSITY OF WASHINGTON, DEPARTMENT OF MATHEMATICS, SEATTLE, WASHINGTON 98195-4350, USA