

MULTIPARAMETER SYMBOLIC SENSITIVITY ANALYSIS ENHANCED BY NULLOR MODEL AND MODIFIED COATES FLOW GRAPH

Irina ASENOVA¹, Franciszek BALIK²

¹Department Electrical Engineering, Faculty of Communication and Electrical Equipment, Todor Kableshkov University of Transport, Geo Milev 158 Street, 1574 Sofia, Bulgaria

²Department of Field Theory, Electronic Circuits and Optoelectronics, Institute of Telecommunications, Teleinformatics and Acoustics, Wrocław University of Technology, 27 Wybrzeze Wyspianskiego Street, 50 370 Wrocław, Poland

irka_honey@yahoo.com, franciszek.balik@pwr.wroc.pl

Abstract. *In symbolic sensitivity analysis very important role plays the number of additionally generated expressions and in consequence additional number of arithmetical operations. The main drawback of some methods based on the adjoint graph or on the two-graph technique, i.e. the necessity to multiply analyze the corresponding graph, is avoided. Advantages of the method suggested are that, the matrix inversion is not required and the Coates graph is significantly simplified. Simplifications of the method introduced in this paper lead to the significant reduction of the final symbolic expressions without violation of accuracy. This simplification method can be considered as SBG-type and has an important impact on symbolic analysis. A special software tool called "HoneySen" has been developed to implement the suggested method. In the paper, it was shown that the presented method is more effective than the transimpedance method taking the number of arithmetical operations and the circuit insight into consideration. Comparison results for the multiparameter sensitivity calculations of the voltage the transfer function for a fourth-order low pass filter and a second-order high-pass filter are presented.*

Keywords

Modified Coates flow graph, nullor model, symbolic sensitivity analysis, symbolic transfer functions, transimpedance method.

1. Introduction

The symbolic analysis has been widely applied for analog circuit analysis and synthesis [1]. At the circuit

level, a formal technique has been used to obtain a network transfer function to calculate the behavior or characteristics of a circuit by the symbolic circuit parameters [2]. A symbolic simulator performs the same function as the designers traditionally do by hand analysis. The difference is that the analysis is now much faster done by a computer, and does not make many errors. The sensitivity analysis plays an important role in determining the critical design variables in analog circuit synthesis [3], [4].

According to the classical formulae, the calculation of the first-order transfer function sensitivity requires finding the corresponding derivatives, and that is the main problem of the sensitivity analysis. Once the circuit equations are derived, the relevant derivatives of each equation can be computed symbolically and then the differential sensitivity can be calculated using the chain rule of differentiation. This solution was proposed first in [5] and was extended in [6] by representing a sequence of expressions (SoE) as directed acyclic graph (DAG) and providing an algorithm for analyzing the DAG. Although the method is conceptually simple it does not always generates the optimal sequence [6]. This is due to the fact that the number of additional expressions, required for sensitivity calculations, heavily depends on the position of the symbol with respect to which the derivatives are calculated. The Transimpedance (TI) method overcomes these drawbacks [4]. The main drawback of some methods based on the adjoint graph is the necessity to analyze the corresponding graph twice [1] and the suggested method gets over it.

The nullator and norator (see [7]) are elements that could facilitate the symbolic sensitivity analysis of active circuits by applying nodal analysis (NA). Nullor-based models have been generated taking into account

the ideal behavior of the active devices [7]. All controlled sources, transistors and op-amps can be modeled using only resistors, capacitors, and nullors. In this manner, any analog network can be modeled with nullors and impedances, and the equivalence between them is introduced in [8]. The nullor equivalents of the pathological elements voltage mirror and current mirror and their application to symbolic analysis were introduced in [8]. In this paper a new approach for the multiparameter sensitivity (MS) analysis is described. The nullor model of the active circuit is a starting point for the sensitivity analysis. On the other hand, Coates flow graph is useful and often used in the network theory and in the linear system theory [9]. The symbolic analysis of a synthesized network can be implemented and simplified on the base of the modified Coates flow-graph (MCFG), [10], decreasing the arithmetical operations in circuit sizing process. In contrast with the other approaches the nullor model is combined with the modified Coates flow graph aiming at the calculation of the MS in a symbolic form in this paper.

On the base of [11], a method for MS analysis is described, which is devoid of these drawbacks contained in the previous methods mentioned above. Further, the paper presents a detailed description of the multiparameter sensitivity analysis (in section II). In section III, the proposed method has been applied to the nullor model of the fourth-order low-pass filter and the second-order high-pass filter for calculation of its multiparameter sensitivity. In section IV the comparison of the presented method with the TI method is performed. Section V presents the conclusions and suggestions for future research.

2. Multiparameter Symbolic Sensitivity Analysis

The multiparameter symbolic sensitivity analysis of a performance function with respect to the circuit parameters helps to determine parameters, which are critical for performance degradation and relatively insignificant. Suppose that p parameters, $p = [G, C, g_m]$, exist having very small fractional perturbations from their nominal values. This paper proposes a new method of multiparameter symbolic sensitivity analysis based on a nullor model and modified Coates flow graph (SANMCFG). The sequence of the method main steps is as follows:

- Composing an equivalent nullor circuit of the active network.
- Presentation of the nullor circuit by a modified Coates flow graph and reduction of the circuit complexity by means of transformation of the

MCFG in order to take into account the influence of nullators and norators.

- Determination of the transfer functions and the multiparameter symbolic sensitivity.

2.1. Composing of an Equivalent Nullor Circuit

Determination of the symbolic transfer function sensitivity with respect to each parameter is based on the nullor model of the active network.

Let us assume that there are $m + n + R + 1$ nodes, and R nullors in the equivalent nullor circuit N composed by circuit designers. In accordance with [11], the nodes, numbered from 1 to m represent network sources, nodes from $m + 1$ to $m + n$ are inner nodes, that all or some of them can be considered as output nodes, and the node $m + n + 1$ is the grounded node for the circuit. The sequence of numbering the nodes in the equivalent nullor circuit is very important for the symbolic multiparameter sensitivity analysis and for the special software developed. The sequence is determined as follows:

- incoming (sources) nodes - $1, \dots, m$,
- outgoing nodes - $m + 1, \dots, m + n$ as follows:
 - h nodes, connected to edges with passive elements,
 - N_e nodes, connected with the ground by means of a norator,
 - $2N_f$ nodes, connected with N_f norators. When two or more norators have common nodes in the equivalent nullor circuit, then the pairs of the nodes connected with the norators must be numbered in ascending order in the income data,
 - N_{fr} nodes, connected with a norator that is situated between 2 nodes, one of them is connected with a nullator,
 - n_f nodes, that is one of the two nodes, connected with the nullators. When a nullator or more nullators are connected with the source node, because the source node is already numbered, this node is missed at that point,
 - $R = n_f + n_e$ nodes that are removed, as follows: n_f nodes, corresponding to the second node, connected with the nullators; N_e nodes, connected with the nullators grounded.

Accordingly, an equivalent nullor network N is composed which is presented by an initial modified Coates flow-graph. The algorithm written in [11] looks for the definiteness of all outgoing vertices, i.e. each outgoing vertex must have at least one incoming and one outgoing edge. An approach to reduce the nullor circuit complexity and order of the admittance matrix is presented in [12]. This approach describes five rules for transformation of the initial modified Coates flow-graph in order to take the nullator-norator pair influence on the network. The validity of the rules is verified by comparison of the reduced admittance matrix with the one obtained using the nullor properties described in [7]. It can be seen that having applied the rules, R vertices are removed from the initial modified Coates flow-graph. The number of these vertices is equal to the number of nullators in the equivalent nullor circuit, and they are strictly determined, i.e. $R = n_f + n_e$. These nodes correspond to the last ones in sequence of numbering the nodes in the nullor circuit. In this manner, it is very clear between which two nodes the transfer function is determined after the admittance matrix reduction.

2.2. Determination of the Transfer Functions and the Multiparameter Symbolic Sensitivity

The definition for the normalized sensitivity of rational transfer function $T_{kq}(s)$ with respect to circuit parameter $\mathbf{Y}(s)$ of a network element given by [1] is used to formulate the normalized (relative) sensitivity $S_{\mathbf{Y}(s)}^{T_{kq}(s)}$ for determined frequency, when this parameter participates in more than one edge in the modified Coates flow graph:

$$\begin{aligned} S_{\mathbf{Y}(s)}^{T_{kq}(s)} &= \frac{\mathbf{Y}(s)}{T_{kq}(s)} \frac{\partial T_{kq}(s)}{\partial \mathbf{Y}(s)} = \\ &= \frac{\mathbf{Y}(s)}{T_{kq}(s)} \sum_{j,i} \frac{\partial T_{kq}(s)}{\partial Y_{ji}(s)} \frac{dY_{ji}(s)}{d\mathbf{Y}(s)}, \end{aligned} \quad (1)$$

where $Y_{ji}(s) = a_{ji}(s) + \mathbf{Y}(s)$ is an element of the admittance matrix $\mathbf{Y}(s)$ for determined frequency; $a_{ji}(s)$ contains other network parameters, participating in this element.

The modified Coates flow graph allows us to simplify the first-order sensitivity analysis on the base of certain network partial transfer functions. According to [13], derivative $\partial T_{kq}(s)/\partial Y_{ji}(s)$ in (1) is represented by partial transfer functions $T_{iq}(s)$ and $T_{kj}(s)$, between the pair nodes i, q and k, j respectively, and substituted by:

$$\frac{\partial T_{kq}(s)}{\partial Y_{ji}(s)} = T_{iq}(s)T_{kj}(s), \quad (2)$$

for $i, q = 1, 2, \dots, n$; $k, j = 2, \dots, n$.

Partial transfer functions $T_{k1}(s)$ and $T_{kj}(s)$, determinants D_{k1} and D_{kj} respectively, and determinant D can be obtained by MCFG \mathbf{G}^{MC} and its sub-graphs \mathbf{G}_{k1}^{MC} , \mathbf{G}_{kj}^{MC} and \mathbf{G}_0^{MC} respectively, as follows:

- \mathbf{G}_0^{MC} is obtained by \mathbf{G}^{MC} due to the removal of all edges from the vertex-source,
- \mathbf{G}_{k1}^{MC} , for $k, j = 2, \dots, n$, is obtained from \mathbf{G}^{MC} due to the removal of all outgoing edges, including the self-loop in vertex k and moving the vertex-source into vertex k ,
- \mathbf{G}_{kj}^{MC} is obtained from \mathbf{G}_0^{MC} by removing all outgoing edges, including the self-loop, from vertex k , as well as by removing all incoming edges, including the self-loop, from vertex j . An edge $y_{jk} = -1$ is added.

Consequently:

$$D_{kq} = \sum_{Q=1}^R (-1)^{N_Q} (P_Q), \quad (3)$$

where n_Q is the number of the loops in Q -th separation of loops in the sub-graph; R - the number of separations of loops in the sub-graph; P_Q - the product of loop transmission coefficients in Q -th separation. Every separation of loops must be incident to all graph vertices and every one vertex must be incident with only one incoming and one outgoing edge.

The algebraic value of multiparameter sensitivity MS^T of transfer function $T(s)$ for determined frequency is

$$MS^T = \sum_{i=1}^p S_{Y_i(s)}^T. \quad (4)$$

Using the algorithm presented in [11], a special software tool called "HoneySen" is developed to perform multiparameter symbolic sensitivity analysis based on the equivalent nullor circuit and the modified Coates flow graph. The interested readers can receive the software from Irka.honey@yahoo.com.

3. Examples

In this section, an example concerning the symbolic analysis of an analog circuit is presented to show that the proposed symbolic method is applicable to multiparameter sensitivity analysis.

3.1. Example 1

Let us find the multiparameter sensitivity of the voltage transfer function $T_{51}(s) = U_0/U_i$ for the fourth-

order low-pass filter shown in Fig. 1-(a). Its equivalent nullor circuit is presented in Fig. 1-(b). Figure 2-(a) shows the initial form of the MCFG. Considering the sequence of numbering, vertices (nodes) 8 and 9 in the initial flow-graph (equivalent nullor circuit) are removed. These nodes are strictly determined in the input data. They correspond to the last ones in the sequence of numbering the nodes.

According to rules (1), (3) and (5) of transformation of the initial flow graph described in [12], MCFG follows and it is shown in Fig. 2-(b). Having in mind (4) the algebraic value of multiparameter symbolic sensitivity is:

$$MS^{T_{51}} = S_g^{T_{51}} + S_G^{T_{51}} + \sum_{i=1}^2 S_{G_i}^{T_{51}} + \sum_{i=1}^2 S_{sC_i}^{T_{51}}, \quad (5)$$

where:

$$\begin{aligned} S_G^{T_{51}} &= \frac{G}{T_{51}}(T_{31}T_{53} - T_{41}T_{53} - T_{71}T_{53} - T_{31}T_{55} + \\ &+ T_{71}T_{55} + T_{71}T_{57}) \\ S_{G_1}^{T_{51}} &= \frac{G_1}{T_{51}} \frac{\partial T_{51}}{\partial G_1} = \frac{G_1}{T_{51}}(-T_{41}T_{56} + T_{61}T_{56}) \\ S_{G_2}^{T_{51}} &= \frac{G_2}{T_{51}} \frac{\partial T_{51}}{\partial G_2} = \frac{G_2}{T_{51}}(-T_{51}T_{57} + T_{71}T_{57}) \\ S_{sC_1}^{T_{51}} &= \frac{sC_1}{T_{51}} \frac{\partial T_{51}}{\partial sC_1} = \frac{sC_1}{T_{51}}(T_{21}T_{52} + T_{41}T_{52} + \\ &+ T_{61}T_{54}) \\ S_{sC_2}^{T_{51}} &= \frac{sC_2}{T_{51}} \frac{\partial T_{51}}{\partial sC_2} = \frac{sC_2}{T_{51}}(T_{31}T_{53} + T_{51}T_{53} + \\ &+ T_{71}T_{55}) \\ S_g^{T_{51}} &= \frac{g}{T_{51}} \frac{\partial T_{51}}{\partial g} = \frac{g}{T_{51}}(T_{11}T_{52} + T_{21}T_{52} - \\ &- T_{21}T_{54} - T_{61}T_{52} + T_{61}T_{54} + T_{61}T_{56}) \end{aligned}$$

Partial transfer functions $T_{21}, T_{31}, T_{41}, T_{51}, T_{61}, T_{71}, T_{52}, T_{53}, T_{54}, T_{55}, T_{56}, T_{57}$ and determinants $D_{21}, D_{31}, D_{41}, D_{51}, D_{61}, D_{71}, D_{52}, D_{53}, D_{54}, D_{55}, D_{56}, D_{57}$ are obtained using sub-graphs $G_{21}^{MC}, G_{31}^{MC}, G_{41}^{MC}, G_{51}^{MC}, G_{61}^{MC}, G_{71}^{MC}, G_{52}^{MC}, G_{53}^{MC}, G_{54}^{MC}, G_{55}^{MC}, G_{56}^{MC}, G_{57}^{MC}$ and G_0^{MC} respectively.

Determinant D together with the possible combinations of loops R_i , for $i = 1, \dots, 9$ and their products (1F's) obtained using sub-graph G_0^{MC} are presented in [14]. The generated expressions can be easily transformed to the nested form (computer printout) and they are presented in section IV. All partial transfer functions determined are: $T_{21} = D_{21}/D; T_{31} = D_{31}/D; T_{41} = D_{41}/D; T_{51} = D_{51}/D; T_{61} = D_{61}/D; T_{71} = D_{71}/D; T_{52} = D_{52}/D; T_{53} = D_{53}/D; T_{54} = D_{54}/D; T_{55} = D_{55}/D; T_{56} = D_{56}/D; T_{57} = D_{57}/D$.

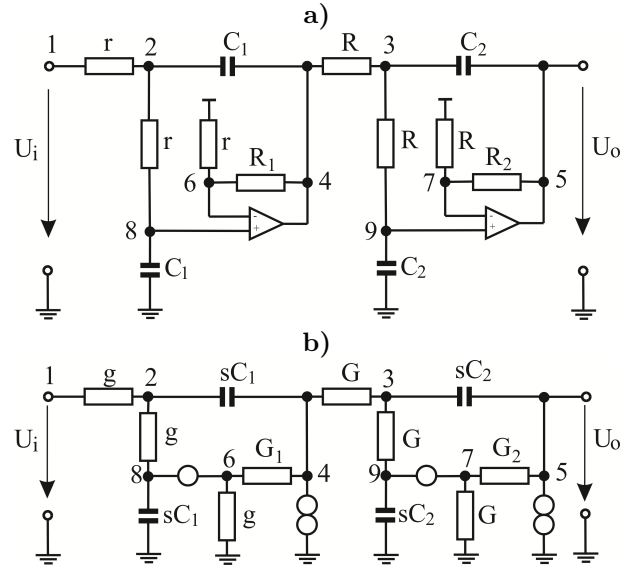

Fig. 1: a) Fourth-order low-pass filter b) its equivalent nullor circuit.

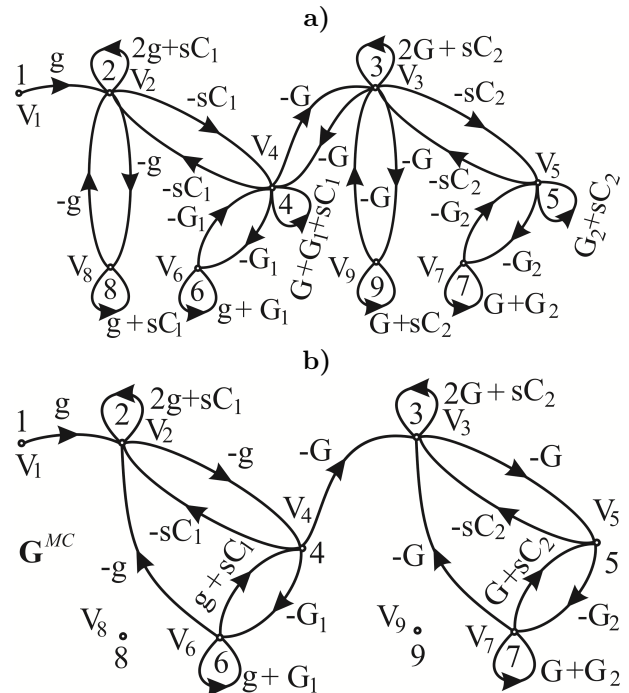

Fig. 2: Coates flow graphs a) initial and b) modified.

4. Example 2

Let us find the multiparameter sensitivity of the voltage transfer function $T(s) = U_0(s)/U_i(s) = U_3/U_1$ for the second-order high-pass filter shown in Fig. 3-(a). The equivalent nullor circuit and its modified Coates flow graph is presented in Fig. 3-(b) and 3-(c), respectively. The reduction of the nullor circuit complexity is related with removing of two nodes ($R = 2$). The symbolic result for the algebraic value of the multiparameter

ter symbolic sensitivity with respect to all parameters is 6.

The magnitude of the multiparameter sensitivities MS_k of the transfer function with respect to all parameters for $f = 1000$ Hz is obtained by the expression:

$$MS = \frac{(G_2(G_1G_4(-sC_2)))}{(sC_2G_1((G_2 + sC_1)G_4 - sC_2G_3)) - 1} + \frac{G_3(-sC_2G_1(-sC_2))}{(sC_2G_1((G_2 + sC_1)G_4 - sC_2G_3)) - 1} + \frac{G_4(-sC_2G_1(G_2 + sC_1))}{(sC_2G_1((G_2 + sC_1)G_4 - sC_2G_3)) - 1} + \frac{sC_1G_1G_4(-sC_2)sC_2G_1G_4(G_2 + sC_1)}{(sC_2G_1((G_2 + sC_1)G_4 - sC_2G_3)) - 1}, \quad (6)$$

$$MS_k = \sum_{i=1}^6 \sqrt{[Re(S_i)_k]^2 + [Im(S_i)_k]^2}, \quad (7)$$

where S_i is the sensitivity with respect to parameter i .

5. SANMCFG Method versus TI Method

In symbolic sensitivity analysis very important role plays the number of additionally generated expressions and in consequence additional number of arithmetical operations. Simplifications of the modified Coates flow graph introduced in this paper lead to the significant reduction of the final symbolic expressions without violation of accuracy. It is completely new contribution and very important. This simplification method can be considered as SBG-type (Simplification Before Generation) and has a significant impact on symbolic sensitivity analysis.

Such simplification method is not known in literature devoted to symbolic sensitivity analysis [4], [5], [6], [8]. In this section we compare the number of arithmetical operations and the circuit insight of the method presented with the two-port transimpedance method, which has been already related to other symbolic sensitivity analysis methods [4].

5.1. Comparison of Arithmetical Operations

In this chapter we will compare the number of arithmetical operations of the modified Coates flow graph method with the number of arithmetical operations of the two-port transimpedance method while calculating the multiparameter sensitivity. We will take the following assumptions: each long arithmetical operation such as multiplication and division denoted as M/D (or

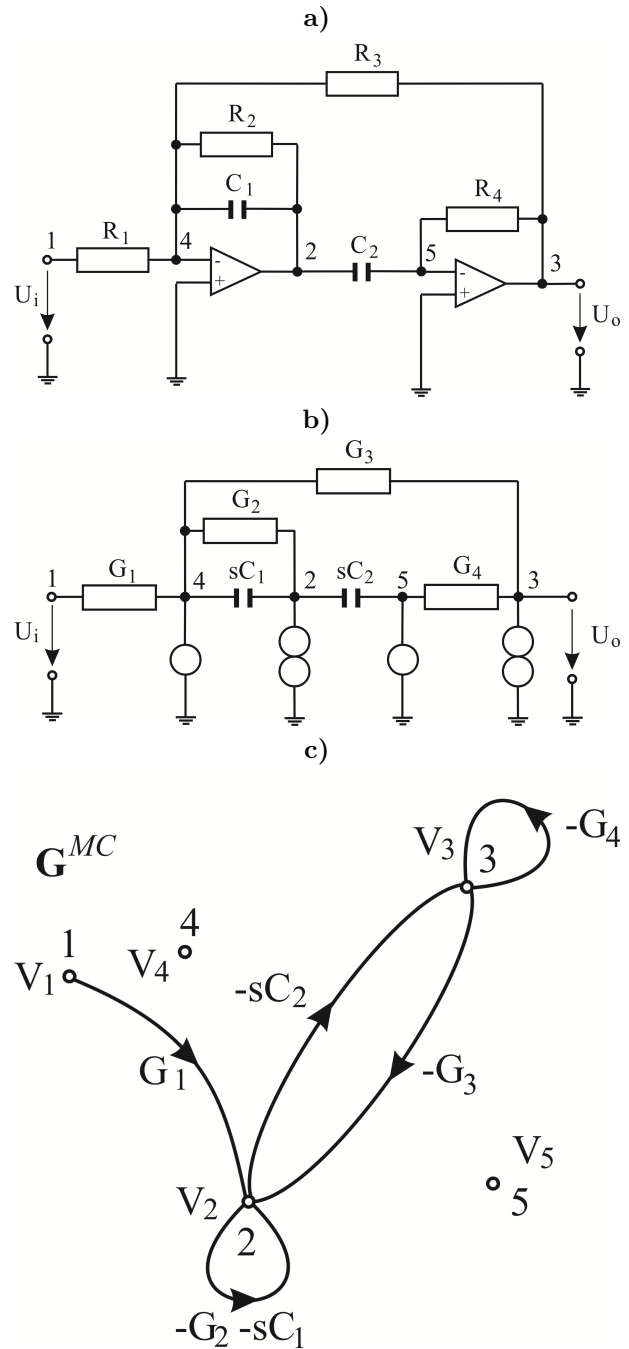

Fig. 3: a) Second-order high-pass filter; b) its equivalent nullor circuit; c) modified Coates flow graph.

Mults) corresponds to 6 flops and each short arithmetical operation such as addition and subtraction denoted as A/S (or Adds) corresponds to 2 flops. Let the sum of all flops will be the arithmetical effectiveness measure. Basing on this measure we will compare our method denoted as SANMCFG with the transimpedance method denoted as TI. The comparison tests were performed for fourth-order LP filter circuit presented in this work as example 1 and shown in Fig. 1 and for the second-order HP filter (example 2), presented in Fig. 3. The manner, in which the number of flops was calculated,

$$S_{G_2}^{T_{31}} = \frac{G_2}{(sC_2G_1((G_2 + sC_1)G_4) - sC_2G_3))(-(-(G_1G_4)(-sC_2)))} \tag{8}$$

is shown in the listing below. This listing concerns the fourth-order LP filter (computer printout):

```
MS = ((S1+S2+S3+S4+S5+S6) / (D)) / (D51); % Mults:2, Adds
:5,Flops:22, D51 = (G^2)*(g^2)*(Y66)*(Y77); %Mults: 5,
Flops: 30, D=((((((Y22)*(Y33)*G1*(Y46)**G2*(Y57))-
((Y22)*G*sC2* G1*(Y46)*(Y77)))-((Y22)*G2*(G^2)*G1*
(Y46)))- (g*sC1* (Y33)* G2*(Y57)*(Y66))) + (g*sC1*G*sC2*
(Y66)*(Y77)))+(g*sC1*G2* (G^2)*(Y66)))-(G1*(g^2)*(Y33)*
G2*(Y57)) + (G1*(g^2)*G*sC2* (Y77)))+G1*(g^2)*G2*(G^2)
% Mults: 45, Adds: 8,Flops: 286,s=j*2*?*f;% f-frequency
Mults: 2, Flops: 12, sC1= s*C1; sC2= s*C2; % Mults: 2,
Flops: 12
Y22=2g+sC1; Y33=2G+sC2; Y46=g+sC1; Y57=G+sC2; Y77=G+G2;
Y66=g+G1; % Adds: 6, Flops: 12% Total SM Mults: 56,
Adds: 19, Flops: 374 S1 = (g)*(D*D52+(2*D21-D61)*D5)
+(- D21+D61)*D54 + D61*D56);
% Mults:6, Adds:5, Flops:46, Total S1 Mults: 97, Adds:
18, Flops: 618S2 = ... ; Flops: 494, S3 = ...; Flops:
252,S4 = ...;Flops: 228, S5 = ...; Flops: 352, S6 = ...;
% Flops: 264,%Total MS Mults: 404,Adds: 79, Flops: 2582
```

Expressions for S_i are given in [14]. The results of calculations are collected in Tab. 1 and compared with those obtained by using the transimpedance method.

Tab. 1: Comparison of TI and SANMCFG arithmetical operation measures in case of fourth-order LP filter.

Sens. Function	Methods for Symbolic Analysis	M/D	A/S	Flops
$S_g^{T_{51}}$	SANMCFG(S1)	97	18	618
	TI	88	54	636
$S_g^{T_{51}}$	SANMCFG(S2)	97	18	618
	TI	88	54	636
$S_g^{T_{51}}$	SANMCFG(S3)	97	18	618
	TI	88	54	636
$S_g^{T_{51}}$	SANMCFG(S4)	97	18	618
	TI	88	54	636
$S_g^{T_{51}}$	SANMCFG(S5)	97	18	618
	TI	88	54	636
$S_g^{T_{51}}$	SANMCFG(S6)	97	18	618
	TI	88	54	636
SM	SANMCFG	97	18	618
	TI	88	54	636
Total flops SANMCFG		404	79	2582
Total flops IT		362	209	2590

Similar calculations were made for the second-order HP filter, for which we obtained the following number of total flops: for SANMCFG 190 and for TI 456. We see, that in regard to arithmetical operations measure, the SANMCFG method is superior to TI method in case of smaller circuits and comparable to TI method in case of bigger circuits (see Tab. 1). For LP fourth-order filter the SANMCFG method needs 2582 flops while TI method needs 2590 flops. On the other hand, for HP second-order circuit the SANMCFG method needs 190 flops while TI method needs 456 flops.

Symbolic methods generate symbolic expressions in different forms, which need a different number of arithmetical operations. This measure strongly depends on the form of representation of multiparameter sensitivity function. In the above comparisons, the performance measures were calculated as a sum of partial measures of partial relative sensitivities, because the multiparameter sensitivity represents such sum. For the fourth-order LP filter, the generated expressions can be easily transformed to the nested form, shown below (computer printout):

```
s = j*2*?*f;% f - frequency,% Mults: 2, Flops: 12, sC1=
s*C1; sC2= s*C2;% Mults: 2, Flops: 12, Y22=2g+sC1; Y33=
2G+sC2; Y46=g+sC1; Y57=G+sC2;Y77=G+G2; Y66=g+G1; %Adds:
6, Flops: 12,D21=((g*(Y33)*G1*(Y46)*G2*(Y57))- (g*G*sC2*
G1*(Y46)*(Y77)))- (g*G2*(G2)*G1*(Y 46));%Mults: 15,Adds:
2,Flops:94,D31=...;%Flops:30,D41=...;%Flops:94,D51=...;
Flops:30,D52 = ...;%Flops :24,D53= ...;% Flops:76
D54=...;Flops:24,D55=...;%Flops : 76,D5 = ...;%Flops:50
D57 = ...;Flops : 154,D61 = ...;%Flops :94,D71 = ...;
%Flops : 30, D = ...;%Mults : 45,Adds : 8,Flops : 286
MS = ((g * (D * D52 + (2 * D21 - D61) * D52 +(-D21+D61)
*D54+D61*D56)+G*((D31-D41-D71)*D53+(-D31+D71)*D55+D71*
D57)+G1*((-D41+D61)*D56)+G2*((-D51+D71))*D57)+sC1*((D21
+D41)*D52+D61*D54)+sC2*((D31+D51) * D53 + D71 * D55))/
(D))/(D51);
%Mults :22,Adds : 21,Flops : 174;%Total Flops: 1272
```

It should be noticed that if the multiparameter sensitivity is recorded in nested form, shown above, it needs 1272 flops, only. In this representation, the SANMCFG method becomes superior to the TI standard method (without simplifications). The sequence of expressions shown above can be directly calculated in Matlab environment.

5.2. Comparison of Circuit Insights

Let us look at the example 2 (HP second - order filter) more precisely. The SANMCFG method generates the following expression of the sensitivity function $S_{G_2}^{T_{31}}$, 8. After small rearrangement we get more familiar form:

$$S_{G_2}^{T_{31}} = \frac{G_2G_4}{G_2G_4 + s(G_4C_1 - G_3C_2)}. \tag{9}$$

If we accept the appropriate time constants equal: $R_3C_1 = R_4C_2$, then this sensitivity will not be depended on frequency and will be equal to -1 . On the other hand, TI method generates the following SoE:

$$S_{G_2}^{T_{31}} = \frac{G_2G_4}{G_2G_4 + s(G_4C_1 - G_3C_2)}. \tag{10}$$

Basing on this SoE, it is not possible to predict the result obtained above, easily. Let us consider the sensitivity measure $\left| \sum_j S_{G_j}^{T_{31}} \right| = |MS|$, for $j = 1, 2, \dots, 6$, where MS is determined by (6). After canceling common factors sC_2G_1 in nominator and denominator in (6) and after small rearrangement we get more familiar form:

$$|MS| = \frac{-G_2G_4 + sC_2G_3 - G_4(G_2 + sC_1)}{(G_2 + sC_1)G_4 - sC_2G_3} - \frac{sC_1G_4 + G_4(G_2 + sC_1)}{(G_2 + sC_1)G_4 - sC_2G_3}.$$

It is not difficult to recognize that nominator is two times greater than the denominator. In this way we obtain very important property of this circuit - its multiparameter sensitivity measure is independent on frequency and is equal to 2: $|MS| = |-2| = 2$. On the other hand, basing on a series of SoE generated by TI method, it is almost impossible to anticipate such important property of this circuit. Resuming, it can be stated, that the SANMCFG method gives much better circuit insight than TI method.

6. Conclusion

A new method of multiparameter symbolic sensitivity determination is considered. It is based on the equivalent nullor model of active devices and modified Coates flow graph. The method suggested in this paper performs multiparameter sensitivity analysis with respect to various circuit parameters to tune circuit parameters during sizing. "HoneySen" software implements the sequence of actions according to the presented method. To verify its applicability two examples are examined: with a fourth-order low pass filter and with a second-order high-pass filter. Advantages of the suggested method are that it is not necessary to multiply analyze the corresponding graph and the modified node admittance matrix inversion is not required. The carried out comparison tests showed that in respect to arithmetical operation measure, the presented method is superior to TI method in case of smaller circuits and comparable to TI method in case of bigger circuits and even superior after transformation the generated expressions into nested form. Moreover, it gives much better circuit insight than the transimpedance method. Further simplification of the generated symbolic expressions is under consideration.

References

[1] VLACH, J. and K. SINGHAL. *Computer methods for circuit analysis and design*. New York: Van Nostrand Reinhold, 1983. ISBN 04-422-8108-0.

- [2] GIELEN, G and W. SANSEN. *Symbolic Analysis for Automated Design of Analog Integrated Circuits*. Norwell: Kluwer Academic Publishers, 1991. ISBN 978-1-4613-6769-7.
- [3] YANG, H., M. RANIAN, W. VERHAEDEN, M. DING, R. VEMURI and G. GIELEN. Efficient symbolic sensitivity analysis of analog circuits using element-coefficient diagrams. In: *Proceedings of the ASP-Design Automation Conference*. Shanghai: IEEE, 2005. vol. 1, pp. 230-235. ISBN 0-7803-8736-8.
- [4] BALIK, F and B. RODANSKI. Calculation of symbolic sensitivities for large-scale circuits in the sequence of expressions form via the transimpedance method. *Analog Integrated Circuits and Signal Processing*. 2004, vol. 40, iss. 3. pp. 265-276. ISSN 0925-1030. DOI: 10.1023/B:ALOG.0000034828.36771.e3.
- [5] LIN, P. M. Sensitivity analysis of large linear networks using symbolic programs. In: *IEEE International Symposium on Circuits and Systems*. San Diego: IEEE, 1992, vol. 3, pp. 1145-1148. ISBN 0-7803-0593-0. DOI: 10.1109/ISCAS.1992.230324.
- [6] ECHTENKAMP, J. A. and M. HASSOUN. Implementation issues for symbolic sensitivity analysis. In: *IEEE 39th Midwest symposium on Circuits and Systems*. Ames: IEEE, 1996. vol. 1, pp. 429-432. ISBN 0-7803-3636-4. DOI: 10.1109/MWSCAS.1996.594190.
- [7] DAVIES, A.C. Nullator-norator equivalent networks for controlled sources. *Proceedings of the IEEE*. 1967, vol. 55, iss. 5, pp. 722-723. ISSN 0018-9219. DOI: 10.1109/PROC.1967.5666.
- [8] FAKHFAKH, M., E. TLELO-CUAUTLE and F. V. FERNANDEZ. *Design of analog circuits through symbolic analysis*. Mexico: Bentham Science Publishers Ltd., 2012. ISBN 978-1-60805-425-1. DOI: 10.2174/97816080509561120101.
- [9] FAKHFAKH, M. and M. PIERZCHALA. Computing symbolic transfer functions of CC-based circuits using Coates flow-graph. In: *5th International Conference on Design and Technology of Integrated Systems in Nanoscale Era (DTIS)*. Hammamet: IEEE, 2010, pp. 1-4. ISBN 978-1-4244-6338-1. DOI: 10.1109/DTIS.2010.5487579.
- [10] CHAN, S. P. and B. H. BAPNA. A modification of the Coates gain formula for the analysis of linear systems. *International Journal of Control*. 1967, vol. 5, no 5, pp. 483-495. ISSN 1366-5820.
- [11] ASENOVA, I., D. GEORGIEV and M. MIHOVA. Multiparameter symbolic sensitivity analysis by

using nullor model and Coates flow graphs. In: *11th International Workshop on Symbolic and Numerical Methods, Modeling and Applications to Circuit Design, SM2ACD*. Gammath: IEEE, 2010, pp. 1–4. ISBN 978-1-4244-6816-4.

- [12] ASENOVA, I. Calculation of second-order symbolic sensitivity by using nullor model and modified Coates flow graph. In: *18th International Conference Mixed Design of Integrated Circuits and Systems (MIXDES)*. Gliwice: IEEE, Catalog Number CFP11MIX-PRT, 2011, pp. 587–591. ISBN 978-83-932075-0-3.
- [13] FETTWEIS, A. *Some general properties of signal-flow networks*. In: J. K. Skwirzynski, J. O. Scanlan, Network and Signal Theory, Peter Peregrinus Ltd., 1973, London.
- [14] ASENOVA, I. and F. BALIK. Multiparameter symbolic sensitivity analysis of active circuits by using nullor model and modified Coates flow graph. In: *9th International Conference ELEKTRO 2012*. Rajecke Teplice: IEEE, 2012, pp. 401–406. ISBN 978-1-4673-1180-9. DOI: 10.1109/ELEKTRO.2012.6225691.

About Authors

Irina ASENOVA was born in 1961 in Bulgaria. She received her M.Sc. from Technical University in Sofia in 1985, and doctorate in 2008. She is employed as an Associate Professor at University of Transport "Todor Kableshkov", Sofia. Her research interests include load forecast in the electrical energy system, symbolic analysis of analog circuits, symbolic sensitivity analysis of the transfer function using modified Coates flow graph and the nullor models of active devices.

Franciszek BALIK was born in 1945 in Poland, employed as a professor at Wroclaw University of Technology, Department of Field Theory, Electronic Circuits and Optoelectronics, Institute of Telecommunications, Teleinformatics and Acoustics, Wroclaw, Poland. His main fields of interests are: circuit analysis and optimization acceleration methods, MCM modelling at cryogenic temperatures, symbolic sensitivity methods. Now he works as scientific advisor and chief executor of National Grant at Electronic Microsystems and Photonics Faculty in the field of cryogenic research.