

University of Nebraska - Lincoln

## DigitalCommons@University of Nebraska - Lincoln

---

Public Access Theses and Dissertations from  
the College of Education and Human Sciences

Education and Human Sciences, College of  
(CEHS)

---

Spring 3-9-2012

# The Impact of Parental Involvement on Preschool Children's Later Language Development in Low-income Hispanic English Language Learners

Yanjie Long

University of Nebraska-Lincoln, [longyanjie@live.cn](mailto:longyanjie@live.cn)

Follow this and additional works at: <https://digitalcommons.unl.edu/cehsdiss>

 Part of the [Bilingual, Multilingual, and Multicultural Education Commons](#)

---

Long, Yanjie, "The Impact of Parental Involvement on Preschool Children's Later Language Development in Low-income Hispanic English Language Learners" (2012). *Public Access Theses and Dissertations from the College of Education and Human Sciences*. 144.  
<https://digitalcommons.unl.edu/cehsdiss/144>

This Article is brought to you for free and open access by the Education and Human Sciences, College of (CEHS) at DigitalCommons@University of Nebraska - Lincoln. It has been accepted for inclusion in Public Access Theses and Dissertations from the College of Education and Human Sciences by an authorized administrator of DigitalCommons@University of Nebraska - Lincoln.

The Impact of Parental Involvement on Preschool Children's Later Language  
Development in Low-income Hispanic English Language Learners

By

Yanjie Long

A Thesis

Presented to the Faculty of  
The Graduate College at the University of Nebraska  
In Partial Fulfillment of Requirements  
For the Degree of Master of Science

Major: Child, Youth and Family Studies

Under the Supervision of Professor Julia Torquati

Lincoln, Nebraska

March, 09, 2012

The Impact of Parental Involvement on Preschool Children's Later Language  
development in Low-income Hispanic English Language Learners

Yanjie Long, M.S.

University of Nebraska, 2011

Advisors: Julia Torquati

Previous research has revealed the importance of parental involvement in children's language development (Raikes, et. al., 2006). However, few studies have focused in detail on the impact of parental involvement on the language development of English Language Learners (ELLs). The purpose of this study is to examine how early and concurrent parental involvement affects preschool children's later language development in a sample of low-income Hispanic ELLs. More specifically, two aspects of parental involvement will be examined: (1) home support of language and cognitive stimulation; and (2) parent emotional supportiveness. The results indicate that early home language and cognitive stimulation and parent emotional supportiveness are associated with English-speaking children's vocabulary at age 2, but not with Spanish-speaking children's language development. Path analysis at age 3 shows that early parent emotional supportiveness predicts English-speaking children's language development, while early home stimulation in language and cognition predicts language development for Spanish-speaking children.

## TABLE OF CONTENTS

	Page
CHAPTER	
1.INTRODUCTION.....	1
Demographic Trends: Spanish speaking children in the US.....	1
Theories of ELL development.....	3
Assimilation and Acculturation.....	3
Zone of Proximal Development.....	4
Theories of Second Language Acquisition.....	5
Family Factors Influencing Language Development of Hispanic ELLs.....	6
Research on Development of Low-Income Hispanic ELLs.....	9
The Impact of Early Family Experiences on ELLs' Later Development.....	10
Research Questions and Hypothesis.....	11
2.METHOD.....	14
Sample .....	14
Measures.....	14
Plan of Analysis .....	19
3.RESULT.....	20
4.DISCUSSION.....	22
Limitation and Future Directions.....	25
TABLES AND FIGURES.....	27
REFERENCE.....	32

## CHAPTER 1

### INTRODUCTION

#### **Demographic Trends: Spanish speaking children in the US**

The Hispanic population in the U.S. increased by 57.9% between 1990 and 2000, from 22.4 million to 35.3 million, compared with an increase of 13.2% for the total U.S. population. Thus, it is important to learn about this rapidly growing population. Latino preschool-aged children in the U.S. represent about 23% of the total U.S. population of preschool-aged children (Pew Hispanic Research Center, 2009b). According to Garcia and Jensen (2007), in the year 2003, about 25% of the infants in the U.S. were born to Hispanic mothers. Among this population, about 64% were born into families with at least one foreign-born parent. The National Center for Education Statistics (2004) reports that among the 14 million language minority children in the U.S. in 1999, about 72% spoke Spanish as their native language.

Early language is considered to be a crucial factor that impacts later academic success (Telles & Ortiz, 2009). Hart and Risley (2006) found that the amount of family talk accounted for children's vocabulary growth, expressive language, and related strongly to intellectual outcomes at ages 3 and 9. For example, Reardon and Galindo (2006) reported that early language use at home predicted later academic success; students whose home language was Spanish entered kindergarten with lower math and reading skills compared with students who speak English at home. While in kindergarten, students who spoke Spanish at home were more likely to make rapid progress in these two subjects. Thus it is meaningful to further learn

factors that impact Hispanic English Language Learners' (ELLs) early language development.

Bilingual children's trajectories in language development differ from one generation to the next. When comparing with Hispanic children from immigrant families (1<sup>st</sup> or 2<sup>nd</sup> generation), Hispanic children from native families (3<sup>rd</sup> or more generation) are more likely to be monolingual English speakers, and they are more likely to demonstrate English proficiency (Hernandez, 2006). Interestingly, Hispanic children from immigrant families are more likely to demonstrate bilingual proficiency, comparing with native families, (Garcia, 2007). This trend of change from bilingualism to monolingualism, from the first and second generation to later generations is called "language shift" (Liberson, Dalto, & Johnston, 1975), which is also referred to as "subtractive" bilingualism (Lambert, 1974).

As intergenerational trend research reveals that the second- and later generations of ELLs perform significantly better than the first immigrant generation in English, another important issue arises: the maintenance of the native language. Although about 33% of Hispanic parents report their children speak both languages at home, research indicates that young bilinguals in the US usually do not develop their native language beyond early conversational skills learned in the home (Garcia & Jenson, 2007). At the expense of developing English skills, many Hispanic children lose native language proficiency (Garcia & Jenson, 2007). Research indicates several factors may have impact on ELLs' native language maintenance. First, ELLs may maintain their native language better if they have more

opportunities to communicate with others at personal, educational, and societal levels using their native language (Lee & Samura, 2005). Second, López's study (2005) indicated that parents with a higher educational level are more likely to value their child's language development in both languages, which plays an important role in child's native language maintenance. Results of this study indicate that these parents are actively taking a role in teaching children reading and writing. Some of them set an only-Spanish rule at home that strongly pushes children to use both languages to communicate and then maintain fluency in both languages.

### **Theories of ELL development**

There are several theoretical approaches to understanding language development of ELLs. Three theories will be discussed below: (1) assimilation and acculturation; (2) zone of proximal development; and (3) theories on second language acquisition. These theories provide conceptual frameworks for understanding characteristics of young ELLs' language development.

#### **Assimilation and Acculturation**

Telles and Ortiz (2009) introduced an assimilation framework and immigrant acculturation theories to understand language development of ELLs. Acculturation refers to groups and individuals' experiences of psychological and social changes when they enter into a new and different cultural context. Assimilation for ELLs means that the third and later generations of immigrants eventually catch up to native human capital and socioeconomic rate levels. For example, they may be indistinguishable from the majority group in education, occupation or income. Thus,

acculturation is more likely to happen within the first generation of immigrants while assimilation helps us understand the experience of the third and later generation.

Based on this theory, we can better understand that young Hispanic ELLs are experiencing very different environments which have different impacts on their language development, according to their immigration status. In short, we cannot simply view all the young Hispanics ELLs as the same population when we are exploring what factors may be influencing their language development.

### **Zone of Proximal Development**

Social interaction is crucial in the language learning process (Telles & Ortiz, 2009). Vygotsky's zone of proximal development is very helpful in understanding how interaction helps to promote children's language learning. The concept of "zone of proximal development" (ZPD) tells us there is an area between what the child is able to do independently and what he/she can achieve potentially when a person with higher level skills/knowledge is guiding or working with the child (Vygotsky, 1978). By interacting with a more knowledgeable person, the child learns more advanced patterns of thinking and communication (Telles & Ortiz, 2009). The early social interactions with parents, siblings and other people provide the foundation for early language development (Barton & Tomasello, 1994; Oshima-Takane, Goodz, & Derevensky, 2008; Teti, Gibbs, & Bond, 1989). Because children spend so much time interacting with their parents in the first years before entering public school, parents play especially important roles in children's language learning process in the early years.



## Theories of Second Language Acquisition

There are many theories of second language acquisition. *Transfer theory* is used to help us understand the acquisition of the second language and the relationship between linguistic properties of the first and second languages (Garcia & Jensen, 2007). According to transfer theory, language skills transfer from the first language to the second. A *cognitive theoretical approach* posits that the acquisition of the first and the second language is attributed to the individual's underlying cognitive abilities, including working memory, phonological short-term memory, phonological awareness, and phonological recoding (Genesee, Geva, Dressler, & Kamil, 2006). *Target Language Influences* proposes that the acquisition of the second language is more likely to be explained by reference to features of the target language being learned, rather than the interaction of linguistic development between the native and second language (Garcia & Jensen, 2007). According to this theory, errors that Hispanic ELLs make during the developmental learning process strongly resemble those made by native English speakers. Thus, the Target Language Influences theory believes that the linguistic challenges associated with learning a second language are more likely inherent in the language itself but not necessarily related to the child's first, or native, language (Garcia & Jensen, 2007). A final theory of second language acquisition is the *Interlanguage theories* that suggest that second language learners create an abstract system of rules of the language they are learning, and this system of rules has its unique organizational scheme. This interlanguage is directly related to the first and second language

(Towell & Hawkins, 1994).

### **Family factors influencing language development of Hispanic ELLs**

Home language environment has been examined in many studies of Spanish-English speaking ELLs. Different home language environments may lead to different trajectories in language development among ELLs (Reardon & Galindo, 2006).

Hispanic children vary in their home language environment. For example, Garcia and Jensen (2007) identified two types of home environments. In the first type of home environment, children acquire English as their first language at home and do not really have opportunities to learn and practice Spanish. They are more likely to be monolingual throughout life, speaking only English. This group of children is more likely to be born into families in which parents are U.S.-born. In contrast, a second type of home environment is comprised of children who speak Spanish at home as their first language, and after they get into public school they begin to learn English. According to Garcia and Jensen (2007), these children are often referred to as “sequential” bilinguals. Others argue that children’s home language environment is more complex than these two types. For example, López, Barrueco, and Miles (2006) reported that among Hispanic children who were born between December 2001 and January 2002, about 34% infants’ primary home language was Spanish, with some English, while 22% primarily speak English, with some Spanish. About 21% of children only speak English at home and 19% of children’s families only speak Spanish. Over one half of these children actually

speak both languages at home, but show differences in the primary home language. They could also be considered as bilinguals. Although we have limited knowledge about it, it will be interesting to learn the different development trajectories of children whose home language are different.

This study will explore the influence of parental involvement on Hispanic young ELL's language development based on different home language use of children. The first and second type of children who speak only one language at home will be examined. Many Hispanic parents have Limited English Proficiency (LEP) (Hernandez, 2006): about 71% of Hispanic children are from immigrant families in which at least one parent is with LEP, and about 49% live in the families with two such parents. Furthermore, Hispanic parents are more likely to be with LEP in comparison to parents from other ethnic minority groups (Garcia & Jenson, 2007), and their children are more likely to live in linguistically isolated homes in which no one over 13 years old speaks English exclusively or very well (Hernandez, 2006). Thus, it is important to examine aspects of home environments associated with children's language development and academic achievement.

Poverty has also been associated with language development of young ELLs. According to Hernandez (2006), Hispanic children from birth to eight years of age are more likely to live below the official poverty level (26%), compared with children of the same age in the general population (16%). Furthermore, Hispanic children who live in homes in which little or no English is spoken are more likely to live in poverty. Hernandez (2006) reported that for Hispanic families in which the

father is not fluent in English, 29% live below the official poverty line, compared to 14% of Hispanic families in which the father is fluent in English. Results of these studies indicate that it is important to consider family economic circumstances in studies of Hispanic ELL children.

Research also indicates that family structure plays a role in language development of Hispanic ELLs (Telles & Ortiz, 2009). For example, a study of Hispanic children participating in Head Start reported that about 69% of the children who do not have two parents at home are primarily English speakers, while about 68% of the children who have two parents at home are primarily Spanish speakers (Telles & Ortiz, 2009). The author found that Latino children with two parents at home performed statistically lower than the children having only one or no parents at home in all the language and early literacy measures except Spanish vocabularies Test de Vocabulario en Imagenes Peabody (TVIP). The research also shows that family size negatively affected English language development, emerging literacy and basic counting variables for Spanish-speaking children; yet it is only negatively associated with letter word identification for English-speaking children. The author explained that Latino children with two parents and more family members at home are more embedded in Spanish-speaking culture than English-speaking culture, so that they perform better in Spanish but statistically lower in English comparing with children who have only one or no parent at home. This result is quite different from our common knowledge about the relationship between the family structure and children's early language development; that is having only

one or no parent at home was not found to positively predict English performance in native English speakers.

### **Research on Development of Low-Income Hispanic ELLs**

Home language environments of preschool-aged Hispanic ELLs enrolled in Early Head Start has been examined, and results indicate that English-speaking Hispanic mothers reported reading to their children more often than did non-English speaking Hispanic mothers (Raikes, Pan, Luze, Tamis-LeMonda, Gunn, Tarullo, Raikes, & Rodriguez, 2006). In addition, this study also found that Spanish-speaking Hispanic children were less likely to have five or more books at home, compared to English-speaking Hispanic children. This research also provided a path model to show the impact of book reading on later vocabulary level among the English-speaking group. According to the model, early maternal reading (14 and 24 months) positively predicts concurrent children's vocabulary which then finally positively predicts later (36 months) vocabulary and cognitive development of children.

However, there is no Early Head Start research that has examined Hispanic children's language development specifically, especially compared different subgroup among this population according to the different home language environment. For example, how do Hispanic children whose home language is mainly Spanish are different in language development from other Hispanic children who mainly speak English at home in Early Head Start sample?

### **The Impact of Early Family Experiences on ELLs' Later Development**

Previous research has documented the importance of early family experiences that may predict later language development and intellectual growth (Hart & Risley, 1996). Research evidence indicates that parent-child interaction has an important influence on children's language development and social development (Hart & Risley, 1999). Whitehurst and Storch's study (2001) indicated that literacy environment, parental expectation for children's school success and parental characteristics, such as IQ, education and so forth are important in influencing children's language skill. Parental involvement, such as parent-child reading (Raikes et al., 2006), was related to reading comprehension performance of preschool-aged ELL children.

However, these studies did not reveal the detail of the impact of parental involvement in ELLs' language development, especially for children whose home language is different from each other. Furthermore, the impact of parental involvement has not been examined in the Hispanic group specifically, especially for low-income Hispanic ELL families. Therefore, the purpose of the present study is to examine how early and concurrent parental involvement affects preschool children's later language development in low-income Hispanic English Language learners. Two aspects of parental involvement were examined in this study: a) Home support of language and cognitive stimulation; and b) parent emotional supportiveness. Home support of language and cognitive stimulation is specifically tested to examine parental involvement in verbal and literacy interaction with the child. Parent emotional supportiveness refers to parental sensitivity, cognitive

stimulation, and positive regard during play with the child; it concerns more on parental behaviors in parent-child interactions. The specific research questions are as follows:

Q1) Does early and concurrent home language and cognitive stimulation and parent emotional supportiveness predict 24 month old Hispanic ELL children's English vocabulary development if children speak English at home?

Hypothesis 1: Early and concurrent home language and cognitive stimulation and parent emotional supportiveness will significantly predict children's English vocabulary development for 24 month old children whose home language is English.

Q2) Do early and concurrent home language and cognitive stimulation and parent emotional supportiveness predict Spanish vocabulary development of 24 month old Hispanic English language learners if children speak Spanish at home?

Hypothesis 2: Early and concurrent home language and cognitive stimulation and parent emotional supportiveness will significantly predict Spanish vocabulary development of 24 month old children whose home language is Spanish.

Q3) Do early and concurrent home language and cognitive stimulation and parent emotional supportiveness predict English vocabulary development of 36 month old Hispanic English language learners if children speak English at home?

Hypothesis 3: Early and concurrent home language and cognitive stimulation and parent emotional supportiveness will significantly predict English vocabulary

development of 36 month old children whose home language is English.

Q4) Do early and concurrent home language and cognitive stimulation and parent emotional supportiveness predict Spanish vocabulary development of 36 month old Hispanic English language learners if children speak Spanish at home?

Hypothesis 4: Early and concurrent home language and cognitive stimulation and parent emotional supportiveness will significantly predict Spanish vocabulary development of 36 month old children whose home language is Spanish.

Q5) Do early home language and cognitive stimulation and parent emotional supportiveness relate to later home language and cognitive stimulation and parent supportiveness? Does one factor of parental involvement, home language and cognitive stimulation, relate to a second factor, parental emotional supportiveness?

Hypothesis 5: Parent emotional supportiveness and home language and cognitive stimulation at each age will predict supportiveness and language and cognitive stimulation at the subsequent ages, respectively; home language and cognitive stimulation at each age will be predicted by the parental emotional supportiveness at the concurrent and previous age.



## CHAPTER 2

### METHODS

#### Sample

The Early Head Start (EHS) data set is used in this study. The whole EHS data included 3001 children in 17 research sites throughout the country of Early Head Start Research and Evaluation Project. The income of families in the EHS program fell below the poverty line. Only the Hispanic sample is included in this study; therefore the analytic sample for this study includes 188 children (90 girls and 98 boys). Children were divided into three groups based on their home language: a) English-speaking group b) Spanish speaking group; and c) Spanish-English speaking group. The size of the Spanish-English speaking group was too small for analysis, and therefore I included only the English-speaking group and the Spanish speaking group in this study. Table 1 shows the sample characteristics divided by home language group and sex of child.

#### Measures

##### Parent Measures

Home support of language and cognitive stimulation and parent emotional supportiveness were used in the present study to represent parent involvement. Descriptive statistics for all variables are presented in Table 1.

**Home Support of Language and Cognitive Stimulation.** Home Support of Language and Cognitive Stimulation was measured at three time points, when the

target child was 14 months, 24 months and 36 months of age. Home Support of language and cognitive stimulation is a factor that is originally from the Home Observation for Measurement of the Environment (HOME) inventory. HOME is used to systematically assess the nature of caring environment in which the child is reared (Caldwell & Bradley, 1984). For infants and toddlers (ages 0 to 3), 45 items were used to assess the home environment. Items were either observed by trained interviewer/assessor or posed as questions to the parents. Most of them were scored as original dichotomous scoring. Respondents may be asked to specify the answer. Thirteen items from HOME were used to create the home language and cognitive stimulation factor in Early Head Start Research and Evaluation Project.

The measure uses both observation and parent self-report. This factor is a measure of the availability of toys and reading materials, parent-child verbal and literacy interaction, and parental encouragement of learning in several domains. It also measures the breadth and quality of the mother's speech and verbal responses to the child during the home visit, as rated by the interviewer; whether the parent encourages the child to learn shapes, colors, numbers, and the alphabet; the presence of books, toys, and games accessible to the child; and whether the parent reads to the child several times per week. The maximum potential score is 13.

**Parent Emotional Supportiveness.** Parent emotional supportiveness was also measured at three time points, 14 months, 24 months and 36 months of age. Parent supportiveness is a subscale of the parent behavior assessed during 3-bag Structured Play Task assessment. Three parent constructs, sensitivity, positive regard, and

cognitive stimulation comprised a single scale, supportiveness. These three constructs were highly intercorrelated ( $r$ 's=.50 to .71) at all three time points (Fauth & Smith, 2002). Sensitivity includes such behaviors as acknowledgement of the child's affect, vocalizations, and activity; facilitating the child's play; changing the pace of play when the child seems under-stimulated or over-excited; and demonstrating developmentally appropriate expectations of behavior. Stimulation of Cognitive Development measures the quality and quantity of the parent's effortful teaching to enhance child's perceptual, cognitive, and linguistic development. Key features include being aware of the child's developmental level, efforts to bring the child above that level, flexibility and timing of instructions or explanations, and use of complex and varied language. Cognitive stimulation involves taking advantage of the activities and toys to facilitate learning, development, and achievement; for example, by encouraging the child to talk about the materials, by encouraging play in ways that illustrate or teach concepts such as colors or sizes, and by using language to label the child's experiences or actions, to ask questions about the toys, to present activities in an organized series of steps, and to elaborate on the pictures in books or unique attributes of objects. Positive regard includes praising the child, smiling or laughing with the child, expressing affection, showing empathy for the child's distress, and showing clear enjoyment of the child. To assess the parent-child interaction, the child and parent were presented with three bags of toys and played together for 10 minutes with toys. The interaction took place in the home and was videotaped. Trained interviewers and assessors administered the protocol

and several graduate students were trained to code the each video. Interactions that were conducted in Spanish were rated by a fluent Spanish-speaking coder. Interrater reliability was ensured in the whole process (Fauth & Smith, 2002).

Constructs assessed on a seven-point scale, from 1 (a very low incidence of the behavior) to 7 (a very high incidence of the behavior).

### **Child Measures**

#### **MacArthur Communicative Development Inventories (CDI) - Vocabulary**

**Production Score** was used to examine children's language development level at 24 months of age. The CDI is a parent-report measure that consists of two inventories, the CDI/Words and Gestures inventory and the CDI/Words and Sentences inventory, each with two sections. The Words and Sentences inventory is specifically for toddlers between 16 and 30 months, which was used in the EHS project for 24-month-old infants. The short version of the CDI/Words and Gestures inventory was used; it consists of an 89-word vocabulary checklist and there are two equivalent short versions of the CDI/Words and Sentence Inventory, both with a 100-word vocabulary checklist. For the short form, internal consistency ( $\alpha$ ) for the toddler form A and B each had an alpha of .99. The vocabulary production test-retest correlations were .74 and .93 for the toddler forms A and B, respectively (Fenson, Pethick, Renda, Dale, & Reznick, 2000). The MacArthur CDI score reflects children's vocabulary development in the home language they use; that is, for children who speak English at home, the MacArthur CDI reports their English vocabulary based on the parent report, while for children who speak Spanish at

home, the CDI scores reflect their Spanish vocabulary development.

**The Peabody Picture Vocabulary Test, Third Edition (PPVT-III)** was used to assess children's English vocabulary at 3 years of age; it measures listening comprehension of spoken words in standard English for children and adults from age 2 1/2 and older (Dunn & Dunn, 1997). The child is presented with four pictures and is asked to point to the picture that matches the word spoken by the interviewer. The PPVT-III was normed on a nationally representative sample of children and adults of various ages so that raw scores can be converted to age-adjusted, standardized scores with a mean of 100 and a standard deviation of 15 (Dunn and Dunn, 1997). In this study, the PPVT-III standard score was used. For the reliability, PPVT-III has an internal consistency range from .92 to .98. The test-retest correlation is .91 to .94 (Administration for Children and Families, 2003).

**The Test de Vocabulario en Imagenes Peabody (TVIP)** was used to assess children's Spanish vocabulary at age 3. The TVIP test measures the listening comprehension of spoken words in Spanish for Spanish-speaking and bilingual children from ages 2 1/2 to 18 (Dunn, Lloyd, Eligio, Padilla, Lugo, & Dunn, 1986). Similar to the PPVT-III, the child is presented with four pictures and is asked to point to the picture that matches the Spanish word spoken by the interviewer. The TVIP was normed on a sample of Mexican and Puerto Rican children of various ages so that raw scores can be converted to age-adjusted, standardized scores with a mean of 100 and a standard deviation of 15. TVIP was designed based on PPVT-Revised; items in PPVT-R were translated into Spanish to assess the vocabulary of

Spanish-speaking children. The internal consistency reliability of TVIP was tested using Spearman-Brown formula with a correlation coefficient of .80, for age 2 to 3 (ACF, 2003).

### **Plan of Analysis**

Multiple regression analysis was used to test Hypothesis 1 and 2. To test hypothesis 3, 4 and 5, two path models were analyzed, for English-speaking (hypothesis 3 & 5) and Spanish-speaking (hypothesis 4 & 5) groups, separately. A t-test of the mean differences was conducted to see if parents from two different groups show differences in their levels of home language and cognitive stimulation and parent emotional supportiveness. No significant differences were found between the two groups in terms of parental involvement level.

## CHAPTER 3

### Results

**Research Questions 1 and 2:** For young ELLs who only speak English at home, multiple regression analysis indicated that early parental involvement, both cognitive stimulation and emotional supportiveness at 14 months positively predicted children's MacArthur CDI vocabulary product score at 24 months,  $p$  value = .04 and .00, respectively. Parent supportiveness at 24 months predicted children's concurrent vocabulary positively with a  $p$  value of .02. For preschool ELLs who spoke Spanish at home, parent involvement at both ages did not predict later vocabulary score at age 2 (Table 3).

**Research Questions 3, 4, and 5:** Research questions 3, 4, and 5 were examined via path analysis. Figure 1 shows the path model of the impact of parent involvement (emotional supportiveness and home language and cognitive stimulation) on children's 36 months English vocabulary score. The model supports the second and the third hypothesis. The model fit was good, with  $\chi^2(8)=12.93$ ,  $p=.11>.05$ ; CFI=.953>.95; RMSEA=.06<.08. Hypothesis 5 was supported: Later parent emotional supportiveness was predicted by previous parent emotional supportiveness at each age point. Parent emotional supportiveness was associated with home language and cognitive stimulation at 14 months and 36 months. Home language and cognitive stimulation at 14 months predicted home language and cognitive stimulation at 24 months. Hypothesis 3 was partially supported. Parent emotional supportiveness at 36 months predicted children's 36 month PPVT score,

but 36 months home language and cognitive stimulation did not.

Figure 2 shows the path model in Spanish-speaking group. The model partially supports the hypothesis 4 and 5. The modified model has a good model fit, with  $\chi^2(6)=9.79, p=.13>.05$ . The home language and cognitive stimulation at each age predict language and cognitive stimulation at the subsequent age, except between 14 months and 24 months. 36 months language and cognitive stimulation positively predict 36 months TVIP score.



## CHAPTER 4

### **Discussion**

This study investigated the impact of early and concurrent parental involvement on children's vocabulary achievement at age 3. Parent involvement was defined for this study as home language and cognitive stimulation and parent emotional supportiveness. The analysis on 24 months MacArthur CDI vocabulary product development shows that early home language and cognitive stimulation and parent emotional supportiveness are more likely to be associated with Hispanic English-speaking children's language development level, but not with Spanish-speaking children's level. Specifically, for children whose home language is English, the early stimulation of language and cognition at home and parent emotional supportiveness at 14 and 24 months significantly predicted their vocabulary development in English at age 2. However, for the Hispanic ELL children who speak Spanish at home, parent involvement did not predict children's later Spanish vocabulary development.

The two path models suggest the differences between two groups of Hispanic ELLs with regard to the impact of parent involvement on children's vocabulary development at age 3. For Hispanic ELLs whose home language was primarily English, early parent emotional supportiveness level was significantly associated with later parent emotional supportiveness and also significantly predicted English vocabulary development at age 3. Early home language and cognitive stimulation level at 14 months was associated with 24 months home language and cognitive

stimulation score. Parent emotional supportiveness level is correlated with the home language and cognitive stimulation at the same age in 14 and 36 months.

For Hispanic children whose home language was Spanish, we found that parents who give children more home language and cognitive stimulation at early ages are more likely to perform better in language and cognitive stimulation at subsequent ages. Spanish-speaking children who obtained more language and cognitive stimulation at home at early ages were more likely to achieve a higher vocabulary level in Spanish at age 3. Effects of early parent emotional supportiveness on Spanish vocabulary scores at age 3 were not found in my model.

The result is consistent with previous studies in reflecting the significant influence of parent-child interaction on children's later language development (Hart & Risley, 1999; Whitehurst & Storch, 2001; Raikes et al., 2006). However, this study further explored the influence of different types of parental involvement (e.g. parental emotional supportiveness vs. home language and cognitive stimulation) on children with different home language background specifically; there were no studies investigated this issue. It is interesting to see the differences that early parent emotional supportiveness has more impact on English-speaking children's language level, while for Spanish-speaking children, early home stimulation in language and cognition shows more effects. Similarly, for children who only speak Spanish at home, although the path model suggests that home language and cognitive stimulation helps them more in their vocabulary development at age 3 than children whose home language is primarily English, their parents do not

perform significantly better than the other group in providing language and cognitive stimulation at home in 36 months.

The impact of the language environment in the community may be one possible reason to explain this difference. For English-speaking children, parents are not the only ones who can interact with them in English, especially after they get into the early care center. As they become older, there are more chances that they could interact with people from the community and the care center whose languages are primarily English. In this way, language and cognitive stimulation from parents still have impact on children's English development, but the impact may be diminished by other factors. For example, as children spend more time in the care center, interactions with teachers and peers may have more effects on their vocabulary level than their parents. On the other hand, parent emotional supportiveness provides emotional support, which may emotionally support children and then promote children's learning outside of home. On the contrary, for children whose home language is primarily Spanish, they have less access to interact with others in their first language outside home. Although they can use their first language with their relatives and friends from the same culture background, they may spend more time with mainstream English speakers from the community and the early care center when they are older, at age 3, for example. Thus, their Spanish vocabulary practices may be more obtained from the language stimulation from parents at home.

### **Limitation and Future Directions**

Firstly, this study was planning to examine the group of children who speak both English and Spanish at home. However, I did not do that part because of the small sample size of this group. Meanwhile, I was also interested in examining children's vocabulary achievement in each language. For example, for children whose home language is Spanish, how does the early parent involvement affect their later vocabulary development not only in Spanish, but also in English? Future studies could explore this question.

Secondly, this study has the problem of the small sample size, because it is using a secondary data that is not specifically designed for research on Hispanic ELLs. Thus, The sample size of Spanish-speaking group is relatively small, comparing with the English-speaking group. It increases the probability of Type II error.

Thirdly, more parent involvement factors should be considered in later studies. For example, parent involvement in school activities is one important factor (Schwartz, 1996). But in this study, because the data set did not include an indicator of this crucial predictor, I didn't include it in the model.

Future research could examine the differences among different groups with different country origins. Previous research indicated that parents' English proficiency levels varied from one group to another, according to different country origin (Zentella, 2005). Parents' English proficiency may have impact on the way parents involve into children's development. For example, parents who are limited

in English proficiency may have less communication with children's teachers, which may have negative effects on children's development.

Also, it will be interesting if we can examine these ELLs' later language development at an older age, the model may vary. As children get older, they could be exposed more to the English environment in the community, school, media and social networks which may lead to a change on the path model show in this study.

Table 1  
*Sample Characteristics*

	Group 1 (English-speaking)			Group 2 (Spanish-speaking)			Whole Sample		
<b>N</b>	134			24			158		
<b>Gender</b>									
<i>Boys</i>	65			15			80		
<i>Girls</i>	69			9			78		
<b>Demographic Information</b>	Mean	SD	Range	Mean	SD	Range	Mean	SD	Range
<i>Family Size</i>	4.08***	1.483	8	5.56***	1.761	7	4.30	1.61	8
<i>Father highest education years</i>	12.00***	1.785	11	7.63***	2.464	9	11.34	2.46	14
<i>Mather highest education years</i>	2.17***	.835	2	1.39***	.761	2	1.60	.85	2

\*\*\*Significant mean differences between two groups,  $p < .001$ .

Table 2

*Descriptive statistics of all the measurements*

	N	Minimum	Maximum	Mean	Std. Deviation
36m TVIP STANDARD SCORE	24	88.00	124.00	96.88	8.32
36m PPVT STANDARD SCORE	134	40.00	125.00	85.44	16.02
14m Macarthur CDI vocabulary product.	163	.00	50.00	12.03	10.58
24m Macarthur CDI vocabulary product.	196	3.00	100.00	58.26	24.04
14m HOME: Lang & Cog. Stim	180	6.00	12.00	9.98	1.54
24m HOME: Lang & Cog. Stim	201	5.00	12.00	10.25	1.37
36m HOME: Lang & Cog. Stim	171	5.00	13.00	10.89	1.70
14m Parent Supportiveness 3-bag	157	1.33	6.33	3.99	1.02
24m Parent Supportiveness 3-bag	155	1.50	6.50	4.03	1.10
36m Parent Supportiveness 3-bag	146	1.33	5.67	3.94	.96

Table 3

*Summary of Multiple Regression Analysis for 24 months Macarthur CDI vocabulary product*

<b>Home</b>	<b>Variable</b>	<b>B</b>	<b>SE (B)</b>	<b><math>\beta</math></b>	<b><i>t</i></b>
	14m HOME: Lang & Cog. Stim	3.065	1.477	.171*	2.075
<b>English</b>	14m Parent Supportiveness 3-bag	7.191	1.859	.319***	3.869
	24m HOME: Lang & Cog. Stim	2.364	1.568	.129	1.508
	24m Parent Supportiveness 3-bag	4.317	1.828	.203**	2.361
	14m HOME: Lang & Cog. Stim	-3.864	4.934	-.202	-.783
<b>Spanish</b>	14m Parent Supportiveness 3-bag	3.145	7.007	.116	.449
	24m HOME: Lang & Cog. Stim	2.398	4.243	.130	.565
	24m Parent Supportiveness 3-bag	9.848	6.378	.356	1.544

Dependent Variable: 24 months Macarthur CDI vocabulary product.



Table 4

*Correlation Table of all the measurements*

	1	2	3	4	5	6	7	8	9	10
1. 14m HOME: Lang & Cog. Stim	1	.42**	.24**	.22**	.02	-.01	.41	.20*	.14	.14
2. 24m HOME: Lang & Cog. Stim		1	.20**	.15	-.04	-.06	.26	.18*	-.02	.08
3. 36m HOME: Lang & Cog. Stim	---	---	1	.16	.01	.22**	.40	.12	.06	.09
4. 14m Parent Supportiveness 3-bag	---	---	---	1	.49**	.29**	.41	.27**	.28**	.31**
5. 24m Parent Supportiveness 3-bag	---	---	---	---	1	.39**	-.03	.20*	.16	.22**
6. 36m Parent Supportiveness 3-bag	---	---	---	---	---	1	.20	.25**	-.03	.07
7. 36m TVIP STANDARD SCORE	---	---	---	---	---	---	1	. <sup>a</sup>	.26	.28
8. 36m PPVT STANDARD SCORE	---	---	---	---	---	---	---	1	.31**	.33**
9. 14m Macarthur CDI vocabulary product.	---	---	---	---	---	---	---	---	1	.47**
10. 24m Macarthur CDI vocabulary product.	---	---	---	---	---	---	---	---	---	1

Note. \* $p < .05$ , \*\* $p < .01$

Figure 1

*Path model of English-speaking group: parental Involvement and later vocabulary score.*

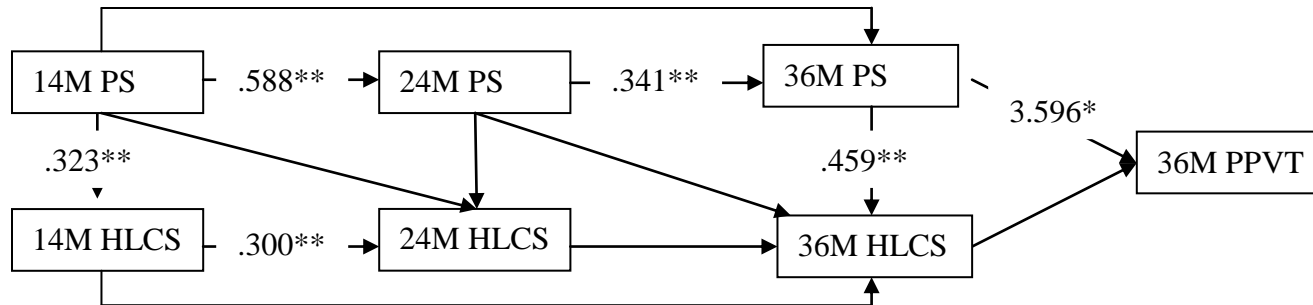
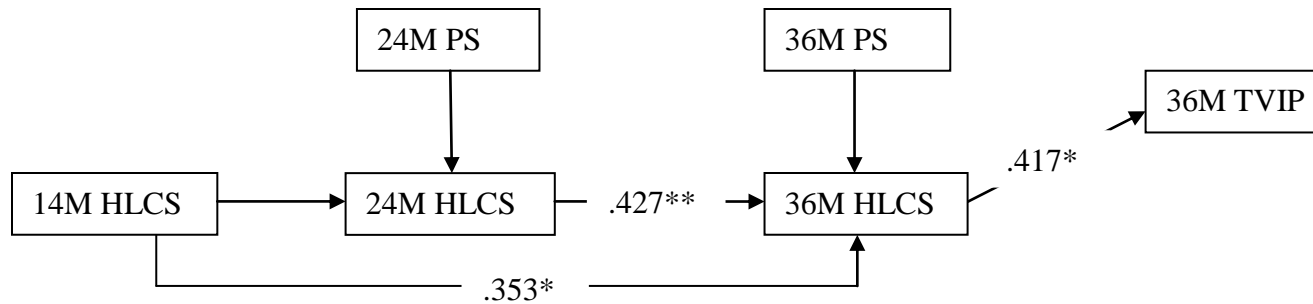

Figure 2

*Path model of Spanish-speaking group: parental involvement and later vocabulary score.*



Notes.  $*p < .05$ ,  $**p < .02$ ,  $***p < .001$ . PS: Parental Emotional Supportiveness; HLCS: Home Language and Cognitive Stimulation.

## References

- Azmitia, M., & Hesser, J. (1993). Why siblings are important agents of cognitive development: A comparison of siblings and peers. *Child Development, 64*, 430-444.
- Alba, R., & Nee, V. (2003). *Remaking the American Mainstream: Assimilation and Contemporary Immigration*. Cambridge, MA: Harvard University Press.
- Brooks-Gunn, J., & Markman, L. (2005). The contribution of parenting to ethnic and racial gaps in school readiness. *The Future of Children, 15*(1), 139-168.
- Barton, M.E., & Tomasello, M. (1991). Joint attention and conversation in mother-infant sibling triads. *Child Development, 62*, 517-529.
- Brown, J.R., Donelan-McCall, N., & Dunn, J. (1996). Why talk about mental states? The significance of children's conversations with friends, siblings, and mothers. *Child Development, 67*, 836-849.
- Cabassa, L. (2003) Measuring acculturation: Where we are and where we need to go. *Hispanic Journal of Behavioral Sciences, 25*, 127-146.
- Cicirelli, V.G. (1994). Sibling relationships in cross-cultural perspective. *Journal of Marriage and the Family, 56*, 7-20.
- Downey, D.B. (1995). When bigger is not better: Family size, parental resources, and children's educational performance. *American Sociological Review, 60*, 746-61.
- Freese, J., Powell, B., & Steelman, L.C. (1999). Rebel without a cause or effect: Birth order and social attitudes. *American Sociological Review, 64*, 207-231.
- Fenson, L., Pethick, S., Renda, C., Cox, J.L., Dale, P.S., Reznick, J.S. (2000) Short-form Versions of the MacArthur Communicative Development Inventories. Applied

Psycholinguistics, 21(1), 91-1.

- García, E. (1983). Becoming bilingual during early childhood. *International Journal of Behavioral Development, 6*, 375-404.
- Genesee, F., Geva, E., Dressler, C., & Kamil, M. L. (2006). Synthesis: Cross-linguistic relationships. In D. August & T. Shanahan (Eds.), *Developing literacy in second-language learners. Report of the National Literacy Panel on Language-Minority Children and Youth* (pp. 153–174). Mahwah, NJ: Erlbaum.
- Goldenberg, C., Gallimore, R., Reese, L., & Garnier, H. (2001). Cause or effect? A longitudinal study of immigrant Latino parents' aspirations and expectations, and their children's school performance. *American Educational Research Journal, 38*(3), 547-582.
- Hancock, T., & Kaiser, A.P. (1996). Siblings' use of milieu teaching at home. *Topics in Early Childhood Special Education, 16*(2), 168-191.
- Hart, B., & Risley, T. (1995). *Meaning differences in the everyday experience of young American children*. Baltimore, MD: Paul H. Brookes Publishing Co.
- Hart, B., & Risley, T. (1999). *The social world of children learning to talk*. Baltimore, MD: Paul H. Brookes Publishing Co.
- Jones, C.P., & Adamson, L.B. (1987). Language use in mother-child and mother-childsibling interactions. *Child Development, 58*, 356-366.
- Lu, Y., & Treiman, D.J. (2008). The effect of sibship size on educational attainment in China: Period variations. *American Sociological Review, 73*(5), 813-834.
- Martínez, M. (1987). Dialogues among children and between children and their mothers. *Child Development, 58*, 1035-1043.

- Maynard, A.E. (2004). Sibling interactions. In U.P. Gielen & J. Roopnarine (Eds.), *Childhood and adolescence, cross-cultural perspectives and applications* (pp.229-252). Westport, CT: Praeger.
- Olsen-Fulero, L., & Conforti, J. (1983). Child responsiveness to mother questions of varying type and presentation. *Journal of Child Language, 10*, 495-520.
- Orellana, M.F. (2003). Responsibilities of children in Latino immigrant homes. *New Directions for Youth Development, 100*, 25-39.
- Ortiz, E., Innocenti, M., & Roggman, L. (2005, April). *Sibling influences on early language development in Spanish-speaking low-income families*. Poster presentation at the Society for Research in Child Development Conference. Atlanta, GA.
- Telles, E.E. & Ortiz, V. (2009) *Generations of Exclusion: Mexican Americans, Assimilation, and Race*. New York, NY: Russell Sage Foundation.
- Oshima-Takane, Y., Goodz, E., & Derevensky, J.L. (1996). Birth order effects on early language development: Do second born children learn from overheard speech? *Child Development, 67*, 621-634.
- Pérez-Granados, D., & Callanan, M. (1997). Parents and siblings as early resources for young children's learning in Mexican-descent families. *Hispanic Journal of Behavioral Sciences, 19*(1), 3-33.
- Reardon, S., & Galindo, C. (2006). K-3 academic achievement patterns and trajectories of Hispanics and other racial/ethnic groups. Paper presented on April 11<sup>th</sup> at the Annual AERA Conference in San Francisco, CA.
- Sénéchal, M., & LeFevre, J. (2002). Parental involvement in the development of

children's reading skill: A five-year longitudinal study. *Child Development*, 73, 445-460.

Schwartz, W. (1996). Hispanic preschool education: An important opportunity. *ERIC Digest* [Online].

Towell, R., & Hawkins, R. (1994), *Approaches to Second Language Acquisition*, Multilingual Matters, Clevedon

Vygotsky, L.S. (1978). *Mind in society: The development of higher psychological processes*. Cambridge, MA: Harvard University Press.

Zajonc, R.B., & Marcus, G.B. (1975). Birth order and intellectual development. *Psychology Review*, 82, 74-88.