

University of Nebraska - Lincoln

DigitalCommons@University of Nebraska - Lincoln

Publications from USDA-ARS / UNL Faculty

U.S. Department of Agriculture: Agricultural
Research Service, Lincoln, Nebraska

1930

HOMES FOR BIRDS

E. R. Kalmbach

Bureau of Biological Survey

W. L. McAtee

Bureau of Biological Survey

Follow this and additional works at: <https://digitalcommons.unl.edu/usdaarsfacpub>



Part of the [Agricultural Science Commons](#)

Kalmbach, E. R. and McAtee, W. L., "HOMES FOR BIRDS" (1930). *Publications from USDA-ARS / UNL Faculty*. 815.

<https://digitalcommons.unl.edu/usdaarsfacpub/815>

This Article is brought to you for free and open access by the U.S. Department of Agriculture: Agricultural Research Service, Lincoln, Nebraska at DigitalCommons@University of Nebraska - Lincoln. It has been accepted for inclusion in Publications from USDA-ARS / UNL Faculty by an authorized administrator of DigitalCommons@University of Nebraska - Lincoln.

Game Forestation ^{II} M
and
Parks Commission ⁽¹⁹⁾

U. S. DEPARTMENT OF
AGRICULTURE
FARMERS' BULLETIN No. 1456

HOMES
for
BIRDS

740



BIRDS appeal strongly to the interest and affection of mankind. Not only do they charm by their graceful forms, harmonious colors, sprightly actions, and usually pleasing notes, but they have an even more important claim upon our esteem because of their great economic value.

Birds feed upon practically all insect pests. They are voracious, able to move freely from place to place, and exert a steady influence in keeping down the swelling tide of insect life.

For economic as well as for esthetic reasons, therefore, an effort should be made to attract and protect birds and to increase their numbers. Where proper measures of this kind have been taken an increase of several fold in the bird population has resulted, with decreased losses from depredations of injurious insects.

This bulletin, one of a series (see footnote, page 2) describing the best methods of attracting birds, deals with nest boxes and other homes for birds, and is adapted for use throughout the United States. It supersedes Farmers' Bulletin No. 609, Bird Houses and How to Build Them.

HOMES FOR BIRDS

By E. R. KALMBACH, *Senior Biologist*, and W. L. MCATEE, *Principal Biologist in Charge, Division of Food Habits Research, Bureau of Biological Survey*

CONTENTS

	Page		Page
Origin of the nest-box idea.....	1	Principles of location of bird houses.....	8
Use of nest boxes in the United States.....	2	Suggestions for homes for various birds.....	9
Increase of birds due to provision of nesting facilities.....	2	Protection against enemies.....	16
Results of increasing the number of birds.....	3	Sanitation of bird houses.....	18
Housing bird enemies of insects.....	4	Provision of nesting material.....	19
Principles of nest-box construction.....	5	Nesting thickets.....	19
		Roosting shelters.....	20

THAT THE AFFECTION felt by many people for birds should manifest itself in the provision of homes for them is highly appropriate. Moreover, aiding birds in their homemaking has a distinctly utilitarian side. From either point of view, provision of nest boxes and other home facilities for birds will be well repaid, and it is the object of this bulletin to make helpful suggestions for the purpose.

ORIGIN OF THE NEST-BOX IDEA

Discussions of the origin of the nest-box idea have placed the date at most a few centuries back, but circumstantial evidence indicates a much greater age for it. Certain uncivilized tribes have the greatest facility for taming wild creatures, and often their homes are shared by a variety of furred and feathered pets. This is no modern development; it is an ingrained trait of the people, and is the very thing that resulted in the subjection of all domesticated animals, a process the beginnings of which are lost in antiquity. We may be sure that primitive man had pets, among them birds, and that without doubt he provided nesting facilities for some of them.

In the cradle of the human race, Asia, we should expect to find indications of primitive care for birds, and the expectation is not disappointed. Early records of Asia Minor testify to the use of doves or pigeons for carrying messages, and such use necessitates the maintenance of houses for the birds; these must have been provided in very early stages of the domestication of the birds, certainly at a remote period. The shelves for swallows in Japanese temples and the feeding towers with nesting places maintained by the Brahmans of India are no innovation; on the contrary, they must have, among these nature worshipers, an antiquity going back to the very beginnings of their religions.

USE OF NEST BOXES IN THE UNITED STATES

It is said that the early colonists of America found that some of the more agricultural tribes of eastern Indians hung up gourds¹ for purple martins on trees trimmed to bare stubs for the purpose. How old the practice is we have no means of knowing, but it has been continued by white men to this day in but slightly modified form throughout the Southeastern States. The provision of houses for purple martins and shelves for cliff (eaves) swallows and barn swallows dates back to colonial times.

Since the modern movements for bird study and protection have been in progress, the number of people furnishing homes for the birds has increased immensely in every quarter of our land. Their success in attracting bird tenants has been great, and their hospitality has been accepted by almost every kind of bird whose original home can be imitated by man.

The roll² of species in the United States known to have nested in bird boxes or on supporting devices built for them now includes 48 names, as follows:

Mountain bluebird.	English sparrow.
Western bluebird.	House finch.
Eastern bluebird.	Purple grackle.
Robin.	Bullock's oriole.
Chestnut-backed chickadee.	Orchard oriole.
Mountain chickadee.	Starling.
Carolina chickadee.	Phoebe.
Black-capped chickadee.	Ash-throated flycatcher.
Plain titmouse.	Crested flycatcher.
Tufted titmouse.	Arkansas kingbird.
Red-breasted nuthatch.	Red-shafted flicker.
White-breasted nuthatch.	Yellow-shafted flicker.
Brown creeper.	Golden-fronted woodpecker.
House wren.	Red-headed woodpecker.
Bewick's wren.	Downy woodpecker.
Carolina wren.	Hairy woodpecker.
Mocking bird.	Screech owl.
Brown thrasher.	Saw-whet owl.
Violet-green swallow.	Barn owl.
Tree swallow.	Sparrow hawk.
Barn swallow.	Mourning dove.
Cliff swallow.	Wood duck.
Purple martin.	American goldeneye.
Song sparrow.	Hooded merganser.

INCREASE OF BIRDS DUE TO PROVISION OF NESTING FACILITIES

Not only is it possible to attract numerous species of birds by supplying boxes and other nesting facilities, but it has been amply proved that the total bird population on a given area can be raised far above normal by these and other methods of attraction.³

The average number of birds over the Eastern United States is a little more than one pair to the acre, but it seems fairly easy to increase this number in suburban, residential, and parked areas to about 10 pairs to the acre. This has been accomplished at Golden

¹A leaflet, No. 36, Gourds for Bird Houses and Other Purposes, is available from the Superintendent of Documents, Washington, D. C., at 5 cents a copy.

²Information furnished the Biological Survey as to species additional to this list will be appreciated.

³For information on the use of protective devices, food-producing plants, and winter feeding, consult Farmers' Bulletins on "How to attract birds," relating to the following sections of the country, respectively: No. 621, Northeastern States; 760, Northwestern States; 844, Middle Atlantic States; and 912, East Central States; also No. 1644, Local Bird Refuges, of general application.

Gate Park, San Francisco, for instance, with 404 pairs to 40 acres; at Olney, Ill., 70 pairs to 8 acres; and at Chevy Chase, Md., 224 pairs to 23 acres. Even higher records have been made, as 135 pairs to 5 acres at Wild Acres, Md., near Washington, D. C.,³ and the number may run up to a much larger figure on a single acre where a thriving colony of purple martins is domiciled.

RESULTS OF INCREASING THE NUMBER OF BIRDS

The larger the number of birds the greater the drain upon their food supply. If this food supply consists chiefly of injurious insects, man profits; if of the products of his cultivation, he suffers. All things considered, however, it is better to have more birds, for, although the injurious individuals or kinds can be controlled or suppressed, the useful species, if not present in time of need, can not be hastily summoned.

Experience shows that those who have increased the number of birds on their property have had cause for satisfaction rather than regret. A case in point has been contributed by B. R. Bones, of Racine, Wis., who gives the following account of some of the benefits he received from encouraging birds:

I commenced as a companion and disciple of Doctor Hoy over half a century ago, and have fitted my place for a bird paradise, with plenty of trees and shrubbery and 1 acre of lawn. Commencing with a single pair of grackles about 20 years ago, I have now over 200. * * * I counted 17 on the first furrow plowed this spring. White grubs are about played out, and I have not seen a cutworm in five years.

E. H. Forbush, formerly State ornithologist of Massachusetts, was convinced that bird attraction pays. He says:⁴

My first attempt at availing myself of the services of the birds in an orchard was made in 1894-95. * * * The winter birds were attracted to the orchard and frequented the trees during the entire winter. * * * In the fall, winter, and spring they destroyed many thousands of the imagos and eggs of the fall and spring canker-worm moths, the eggs of the tent caterpillar, and probably also the pupae and imagos of the codling moth, besides scales, tinoids, and other enemies of the trees. When spring came, efforts were made to attract the summer birds to the orchard. These attempts met with such signal success that, although most of the eggs and young birds were destroyed by cats, boys, crows, and other agencies, the remaining injurious insects were so completely disposed of by the birds that the trees bore luxuriant foliage during the entire summer and produced a good crop of fruit. This occurred in a season when both the tent caterpillar and the cankerworm were remarkably prevalent. The only other orchard in the neighborhood that produced any fruit whatever was that of the nearest neighbor. This had been partly protected by tarred bands and partly by the birds from my place. Elsewhere in the town most of the apple trees were defoliated, and very few produced any fruit that year.

Forbush has claimed⁵ equal efficiency on the part of the birds in ridding a garden of weeds:

In our garden we attempted to keep the weeds in subjection. This in 1900 was almost an impossibility. In 1901 it was a serious task and necessitated frequent weeding or hoeing all summer and into the fall. In 1902 the labor was much lightened, and this was in part due to the birds. All

³ For details as to these density records consult the series of Department Bulletins on bird censuses: No. 187, 1915; No. 396, 1916; and No. 1165, 1923. The first two are out of print, but may be consulted in libraries.

⁴ "Useful birds and their protection," pp. 150-151, 1907.

⁵ "Two years with the birds on a farm," pp. 12-14, 1908.

farmers know that while hoed crops in the main may be kept nearly free from weeds it is impossible to weed a squash or melon patch without injuring the plants. Such crops invariably foul the land. It is also very difficult to keep all fences and borders of fields clear of weeds. We depended mainly on the birds to take care of such weed seeds as were left in the squash or melon patch or along the borders, and they did their work well.

The first year birds were not numerous enough to destroy all the weed seed; the second year there was hardly enough seed to gather an increased number of birds.

A frequently cited European example of the value of attracting birds also is worth repeating. On the estate of Baron von Berlepsch, in Germany, bird attraction methods of every kind were practised, and among other things more than 2,000 nest boxes were supplied, of which about 90 per cent were occupied. During an outbreak of the oak leaf-roller⁶ other woods in the region were entirely defoliated, but that on the Berlepsch estate stood out as a green oasis. With this example before them, municipal and provincial governments in Germany took up the providing of nest boxes for birds, and more than 9,000 were erected in the Grand Duchy of Hesse alone.

HOUSING BIRD ENEMIES OF INSECTS

Adoption of bird houses as a means of enlisting the services of birds as allies in combating an insect pest was successfully tried out in the case of an outbreak of the larch sawfly⁷ near Manchester, England. From 1908 to 1914, 400 boxes were placed and 81 per cent of them occupied. It was considered that birds did a great deal toward the ultimate control of the pest. In this country boxes have been put up about many cranberry bogs to attract tree swallows as enemies of cranberry moths. In some parts of the South it has long been the practice to supply plenty of gourd nests for martins about fields, for the good the birds do in feeding on crop pests. At Winona, Ind., it is reported that the establishment of several large colonies of purple martins was followed by a great reduction in the numbers of mosquitoes. The use of bird boxes to minimize damage by woodpeckers to telephone poles, houses, and other structures also has been tried to some extent.

A concrete instance of the use of bird boxes in the United States for practical ends is described in the following quotation from C. C. Clute:

I know one farmer in particular who lost during one summer three rows of corn 40 rods long. The corn grew next to a fence-row heavily sodded with bluegrass, which produced swarms of grasshoppers. For the sake of the experiment alone, for this farmer was a skeptic, last spring he put up 21 bird houses, placed 2 rods apart, on the fence along the 40 rods. The houses were some that he and the boys had made during the winter months from dry-goods boxes obtained in town. Thirteen of the 21 houses were inhabited during the following summer, 6 by wrens, 4 by bluebirds, and 3 by colonies of purple martins. The grasshoppers that summer made a rich living for the birds, and when the fall came that farmer had the satisfaction of gathering 23 bushels of corn from the three rows that grew next to the fence, right where there had been no corn at all the year before.⁸

⁶ *Tortrix viridiana*.

⁷ *Nematus erichsonii*.

⁸ Iowa Conservation, vol. 1, no. 1, p. 12, January-March, 1917.

PRINCIPLES OF NEST-BOX CONSTRUCTION

When one recalls the unusual, inconvenient, and dangerous locations sometimes chosen by hole-nesting birds to conduct their family affairs, it would appear that almost any facility, however crude, might serve as an inducement to nest building. When we see a house wren nesting in a discarded tin can, an old hat, the empty sleeve of a scarecrow, or the cranial cavity of a weathered cow's skull, it seems that this species would not hesitate to use anything in the shape of a nest box.

The actual needs of hole-nesting birds are few, and may often be met by a small expenditure of time and work. To make the preferred nesting facilities safer, however, and probably more comfortable for the occupants, certain principles of construction, design, and location need to be observed. A well-built bird house should be durable, rain-proof, cool, and readily accessible for cleaning. Furthermore, by adopting high standards of neatness and rustic beauty in the construction of bird houses, they may be made not only to serve the strictly useful purpose of encouraging beneficial species but also to add a touch of attractiveness to what might otherwise be a prosaic dooryard.

MATERIALS

For the person wishing to construct his own bird houses, wood is by all means the best building material. Metal should be avoided because it is a great conductor of heat. Pottery nest boxes have some points in their favor, but there are no facilities for their manufacture in the average home workshop. Nest boxes constructed of tar paper or similar products have no particular advantage over the wooden ones, and the use of these materials is impracticable for some of the larger houses. In the choice of wood, an easily workable kind, as cypress, pine, or yellow poplar, is preferable; the first-named is the most durable. Sawmill waste (rough slabs with the bark on) furnishes cheap and satisfactory material for rustic houses.

PAINT

Where a rustic finish is not sought, paint is unobjectionable and greatly enhances the weathering qualities of bird houses. Modest tones, as brown, gray, or dull green, are generally to be preferred. Martin houses and others that are placed in exposed situations, however, may be painted white to reflect heat.

PROTECTION FROM RAIN

Roofs should be made with a sufficient pitch to shed water readily; or, if level, or nearly so, they should have a groove cut across the under face of the overhanging part (fig. 1, *A*) to prevent water from draining back into the interior. This overhang in the average house should be from 2 to 3 inches, so as to protect the entrance hole from driving rain. The opening of the nest cavity itself may be bored at an upward slant to aid in keeping out water. A strip of metal or roofing paper often helps to make the ridge of

the nest box thoroughly waterproof; flat roofs should either be wholly covered with some such material or else heavily painted. In latitudes where freezing weather is the rule in winter, bird houses will last longer if the sides are prolonged beyond the bottom of the box, thus draining off water which otherwise might freeze in the crack between bottom and sides and wedge them apart. To provide for the contingency that some water may get inside the box, a few small holes may be made in the bottom.

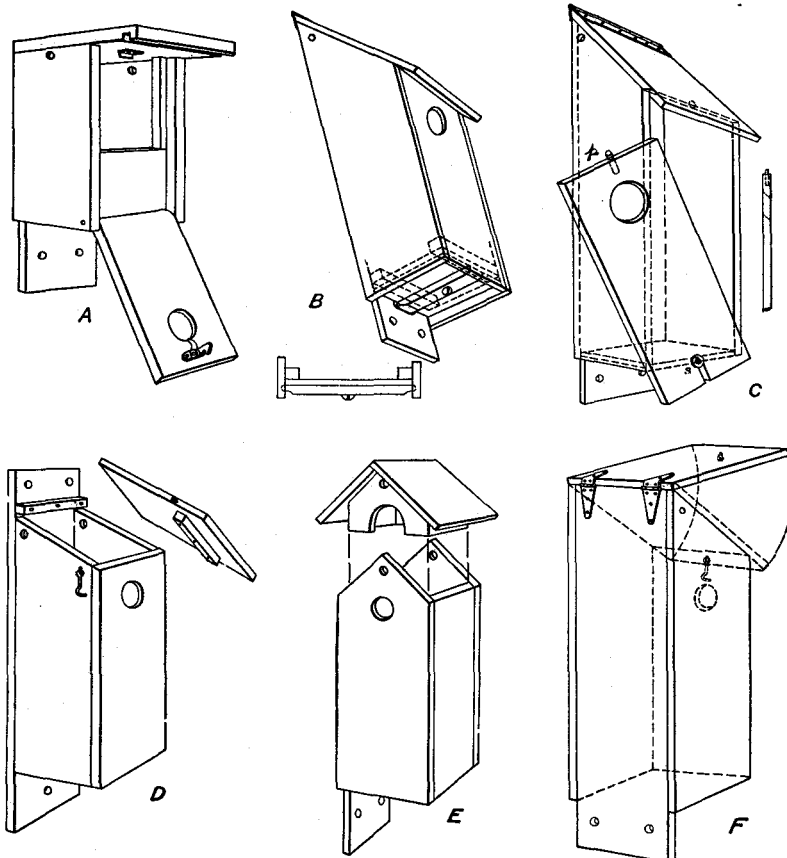

FIG. 1.—Accessible nest boxes. A, Hinged front held up by a catch; B, removable bottom, released by the slight turn of a cleat; C, swinging front, held in place by the pin *p* and by tightening the screw *s*; D and E, removable tops; F, hinged top

PROTECTION FROM HEAT

If attention be paid to the principle of cool construction, death of nestlings during periods of excessive heat may be lessened. Wood is in itself a fairly good heat insulator; but it must be remembered that the interior of the average nest box is small, and a single opening near the top permits little ventilation. One or two small auger holes through the walls near the top of the box will give a limited circulation of air without producing drafts. A double roof or a compartment above the nest proper will also serve as an excellent

insulator. In the colony houses built for martins this feature can be easily included, and the added comfort and safety afforded the nestlings will more than repay for the extra work. In martin houses, however, owing to the low position of the entrance hole and the possibility of producing objectionable drafts, ventilating holes in the compartments themselves should be confined to a single one of small size near the top or left out entirely.

ACCESSIBILITY

All bird houses should be placed so as to be readily accessible and built so as to be easily opened and cleaned. To those interested in studying the life history of the nestlings a readily opened box is a great aid. A number of arrangements may be used to permit inspection of the nest, several of which as applied to simple houses are illustrated in Figure 1. A pane of glass sliding in a groove just beneath the removable side will allow observations without subjecting the birds to exposure or causing a disturbance of the nest material. Other reasons that demand accessibility to the interior of bird houses are mentioned in the section on sanitation, pages 18-19.

TABLE 1.—Dimensions of nesting boxes for various species of regular box-inhabiting birds and the height at which they should be placed above the ground

Species	Floor of cavity	Depth of cavity	Entrance above floor	Diameter of entrance	Height above ground
	Inches	Inches	Inches	Inches	Feet
Bluebirds.....	5 × 5	8	6	1½	5-10
Robin.....	6 × 8	8	(¹)	(¹)	6-15
Chickadees.....	4 × 4	8-10	6-8	1½	6-15
Titmice.....	4 × 4	8-10	6-8	1½	6-15
Nuthatches.....	4 × 4	8-10	6-8	1¼	12-20
House wren.....	4 × 4	6-8	1-6	1	6-10
Bewick's wren.....	4 × 4	6-8	1-6	1	6-10
Carolina wren.....	4 × 4	6-8	1-6	1½	6-10
Violet-green swallow.....	5 × 5	6	1-5	1½	10-15
Tree swallow.....	5 × 5	6	1-5	1½	10-15
Barn swallow.....	6 × 6	6	(¹)	(¹)	8-12
Purple martin.....	6 × 6	6	1	2½	15-20
Song sparrow.....	6 × 6	6	(²)	(²)	1-3
House finch.....	6 × 6	6	4	2	8-12
Starling.....	6 × 6	16-18	14-16	2	10-25
Phoebe.....	6 × 6	6	(¹)	(¹)	8-12
Crested flycatcher.....	6 × 6	8-10	6-8	2	8-20
Flicker.....	7 × 7	16-18	14-16	2½	6-20
Golden-fronted woodpecker.....	6 × 6	12-15	9-12	2	12-20
Red-headed woodpecker.....	6 × 6	12-15	9-12	2	12-20
Downy woodpecker.....	4 × 4	8-10	6-8	1¼	6-20
Hairy woodpecker.....	6 × 6	12-15	9-12	1½	12-20
Screech owl.....	8 × 8	12-15	9-12	3	10-30
Saw-whet owl.....	6 × 6	10-12	8-10	2½	12-20
Barn owl.....	10 × 18	15-18	4	6	12-18
Sparrow hawk.....	8 × 8	12-15	9-12	3	10-30
Wood duck.....	10 × 18	10-15	3	6	4-20

¹ One or more sides open.

² All sides open.

ENTRANCES

Entrance holes for bird houses in most cases are placed near the top of the box, and if the inner side of the lumber used is dressed it

should be roughened, grooved, or cleated to assist the young in climbing to the opening. Houses longer than high are comfortable and convenient, and seem to be liked by some species, particularly birds that do not have an inborn preference for the type used by woodpeckers or birds that are partial to old woodpecker holes. Perches at the entrances seem more of an assistance to enemies than a requirement for the occupants.

DIMENSIONS AND ELEVATION

The simplicity of construction of the single-room bird house does away with the necessity of detailed working drawings in most cases. Table 1 gives the proper dimensions for the various species and the height at which the boxes should be placed above the ground. The design may follow any of the types recommended in succeeding pages.

PRINCIPLES OF LOCATION OF BIRD HOUSES

E. H. Forbush, formerly State ornithologist of Massachusetts, concluded from a statistical study of the subject that failure to attract feathered tenants may be attributed mainly to the following faults: (1) Entrance holes too small for the birds desired; (2) boxes put up in dense woods; (3) boxes placed in trees, and therefore accessible to birds' enemies, instead of on posts or poles; and (4) care not taken to protect birds nesting in boxes from their enemies. Three of these faults concern location—the second and third obviously, and the fourth indirectly, for it is manifestly easier to protect a bird house and its occupants if readily reached. "Easily accessible" means not beyond the reach of an available ladder; houses placed higher inevitably will be neglected. Houses on poles seem more acceptable than others to various birds, and this probably is because they impress the birds as being safer. Isolated trees can actually be made safe with tree guards, but perhaps they do not look so to the birds. Premises fenced against vermin probably will give such security that other precautions against enemies can be dispensed with.

To sum up, it would seem that houses should be fairly low, should not be put in dense woods, and seem more acceptable on poles than in trees. If possible, they should be placed with the opening away from prevailing winds.

It is not well to have a large number of boxes on a limited area, especially those designed to attract the same species. Birds insist on territorial rights, especially in competition with other individuals of the same species, and if houses are too close together conflicts between prospective tenants may result in none being occupied. The purple martin is our only gregarious nesting species that breeds in bird houses, and houses for colonies of these birds should be on poles well separated from trees or buildings. Tree swallows, however, are sociable and several individual boxes for them may be near together.

SUGGESTIONS FOR HOMES FOR VARIOUS BIRDS

Bluebird.—The bluebird is one of the least particular of bird tenants. Any of the types of nest boxes shown in Figure 1 will meet

its needs when built to the proper dimensions and suitably located. Houses of rustic construction are also acceptable. Suggestions along this line may be found in Figure 2. The bluebird is partial to

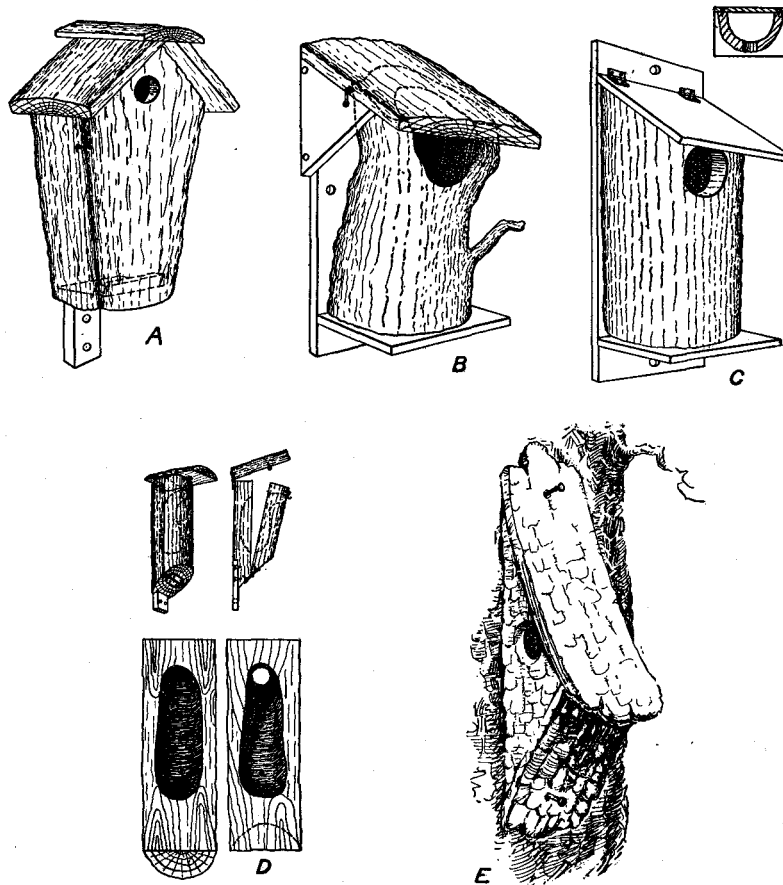

FIG. 2.—Rustic boxes. *A* has a removable front; *B*, a top held by two hooks; and *C*, a simple hinged top. In *D* there is a removable top which releases the front half of the cavity in the manner pictured. The principle embodied in *B* can be applied to the type shown in *E*, made of rough slabs

orchards, and nest boxes may be placed either in the trees themselves or on the posts of a near-by fence, provided measures are taken to prevent attack by cats. A location rather open and sunlit is preferable. The nest material, consisting mainly of dry grasses, is procured by the bird from natural sources.

Robin.—Where such natural sites as well-formed crotches are lacking, robins do not hesitate to use nesting platforms erected for them (fig. 3). These should be either of weathered lumber or of rustic type. They should be placed in partly shaded spots along the main branches of trees or else in the shelter of the overhanging eaves of a shed or porch roof. The birds will gather their nesting material

from natural sources, though in periods of dry weather they may be aided by wetting a spot of bare ground near by to serve as a source of the mud used in the foundation of their nests.

Chickadees, titmice, and nuthatches.—The needs of chickadees, titmice, and nuthatches are very similar. Being creatures of the woodland, all seem to prefer rustic homes built to simulate their natural abodes, but they will not refuse homes made of weathered lumber. Any of the types illustrated in Figure 1, when covered with bark and built to the proper dimensions, will answer the purpose. Suggestions for rustic houses for these birds may be found in Figure 2. Old orchards and the borders of woodlands are the favorite hunting grounds of these birds, and nest boxes placed in such situations are likely to be investigated. Chickadees often nest within a few feet of the ground, but nuthatches and titmice prefer a site of medium or considerable elevation. Food stations provid-

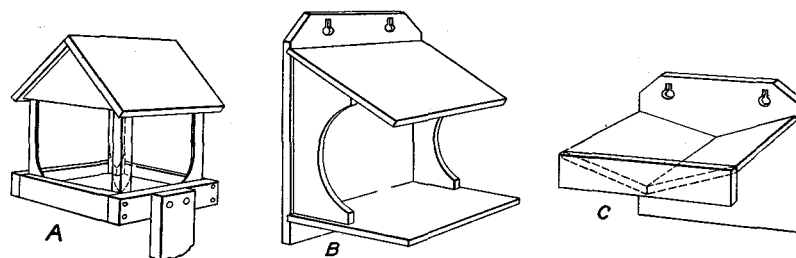

FIG. 3.—Nest brackets and shelves for robins and phoebes

ing suet and nut meats placed on near-by trees are added inducements to these birds to take up their abode.

Warblers and creepers.—Small bark-covered houses closely fitted to the trunks of trees, as suggested in Figure 2, *E*, may be attractive to birds of the nesting habits of the brown creeper and possibly the parula warbler. Brown creepers have nested behind curved pieces of bark tacked over the bark of a living tree. Natural nesting sites for these birds must be decreasing rapidly as the older shaggier-barked trees disappear.

Wrens.—House wrens and Bewick's wrens are the least fastidious of our hole-nesting birds. Almost any sort of a cavity will meet their needs, though boxes of small size with a horizontal slot instead of a round hole for an entrance (fig. 4, *A* and *C*) are best. Wrens take equally well to houses of smooth lumber or of the rustic type. Longitudinal cavities (fig. 4, *A* and *B*) make picturesque and very acceptable homes. Security for nestlings against the house cat may be provided by the structure pictured in Figure 4, *A*, in which a passageway of variable length serves as an entrance to the nest lying below. Nest boxes of the dimensions recommended in Table 1 are better than larger ones, as it seems to be the desire of house wrens to fill with a jumble of sticks whatever cavity they select. The slot opening (fig. 4, *C*) permits the birds to carry in cumbersome material more readily.

Almost any shady or partly sunlit spot about the dooryard or orchard is agreeable both to the house and the Bewick's wrens. A supply of slender twigs about 3 inches long handily placed will aid the birds in collecting nest material. An abundance of wren houses is desirable, as frequently the birds will build "dummy" nests or leave one or more unfinished nests before completing one to their liking.

The Carolina wren, a somewhat larger bird, may be offered houses with slightly larger openings. It is a less familiar species about the immediate dooryard, and consequently nest boxes placed at the border of woodlands or about brushy areas are more likely to be used.

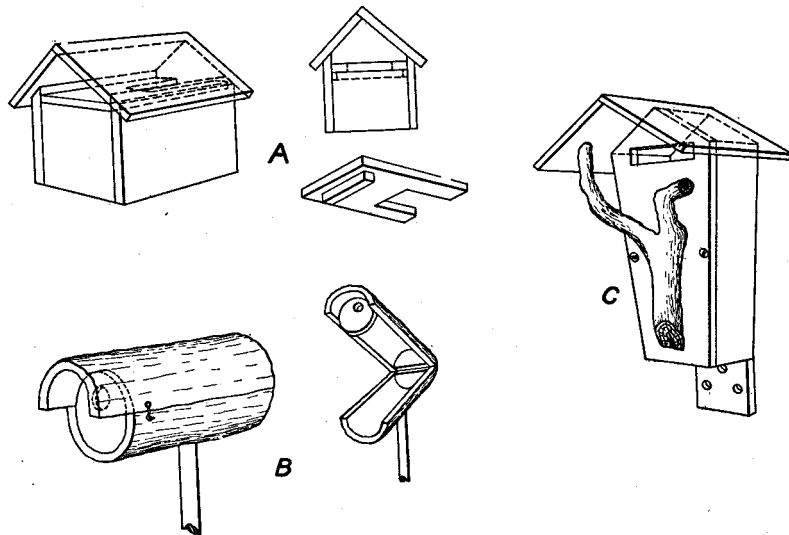

FIG. 4.—Nest boxes suitable for wrens. In *A* the nest cavity is made accessible by removal of a notched board

Catbirds and brown thrashers have been known to use such nesting shelters as those acceptable to robins (fig. 3).

Swallows.—Tree and violet-green swallows may be induced to forsake their natural nesting places in old woodpecker holes by the erection of nest boxes in suitable spots. Boxes of the types shown in Figures 1 and 2 will answer very well for these birds when constructed to the proper dimensions. A dead tree is an excellent site for such nests, and a number of boxes may be nailed to the same stub. Bodies of water hold a great attraction for swallows, and even a small pool in which they can bathe by dipping in flight will assist greatly in efforts toward establishing a colony in artificial homes. Barn swallows will avail themselves of the open or partly covered nest shelves shown in Figure 3 (*B* and *C*) when these are placed under the sheltering eaves of buildings. Long shelves capable of supporting a number of nests will satisfy the gregarious tendencies of these birds, and similar shelves under the roofs of barns or sheds will be utilized if entrance holes are provided in the

gables. Eaves swallows may be encouraged to nest under overhanging roofs by providing a narrow shelf or cleat of rough lumber, which will give them a place of attachment for their mud nests.

Purple martin.—The gregarious nesting habits of purple martins afford the builder of bird houses opportunity to employ his skill and ingenuity in construction, and in the matter of design he may let his fancy run riot. All too frequently, however, such fancies are allowed to overshadow the important factors of accessibility and coolness in the structure. Martin houses are always an attraction to English sparrows, and during the period of the year when the rightful tenants are not present the entrances to the nest cavities should be blocked or the houses taken down and stored. During the

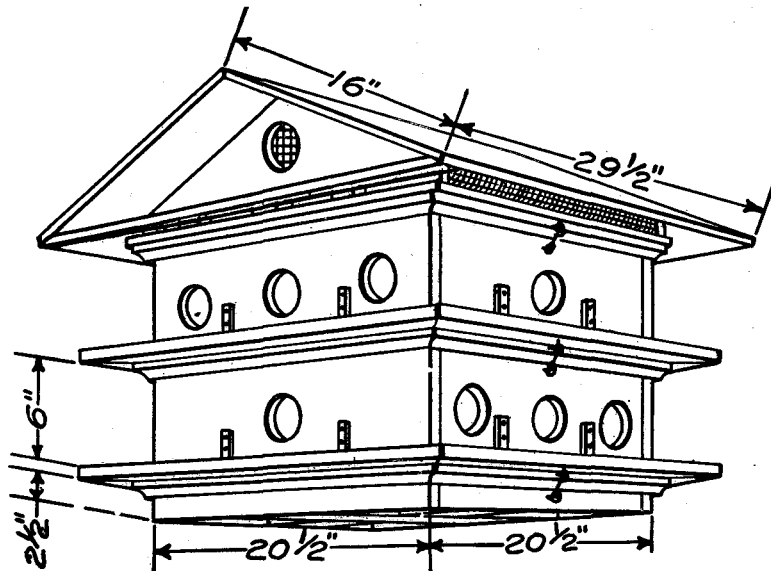

FIG. 5.—Martin house in which the foundation, roof, and each story are built as units of uniform lateral dimensions, permitting the addition of more stories as the colony grows and allowing ready access for cleaning. A central air shaft and an elevated roof, permitting the passage of air beneath the eaves, assure a cool temperature for the interior. A cove molding around the underside of the roof and each story holds the parts in alignment, and pairs of hooks and screw eyes fasten the units together.

nesting season martins are apt to be successful in maintaining their property rights.

An idea that may be employed to advantage for a growing colony is illustrated in the house shown in Figures 5 and 6. Each story is made a unit, and the uniform size permits the addition of other stories as needed. A colony may be started in one story of eight rooms. Three stories, providing 24 rooms, will accommodate about as many martins as would ordinarily be desired in one colony. The roof, built to the same lateral dimensions, fits to the top story, all being held together by hooks and screw eyes. Cleaning is easily done by simply taking the house apart and dumping out the debris. The temperature within the house is kept down by air circulation through the passage formed by cutting out the floors of what would otherwise be central compartments. The roof, raised slightly above

the top of the upper story, also permits the passage of air from the central shaft. The entire house with its support may be arranged for lowering in the manner illustrated in Figure 7, or, if the pole is set firmly in the ground, a ladder leaned against it will permit taking down the house section by section. Such a house of two stories built of soft pine will weigh about 65 pounds. Houses for martins should be situated in open spaces and are usually painted white with neat trimming of a darker color. As with swallows, water has an attraction for these birds, and a near-by pond or stream will increase the probability of establishing colonies.

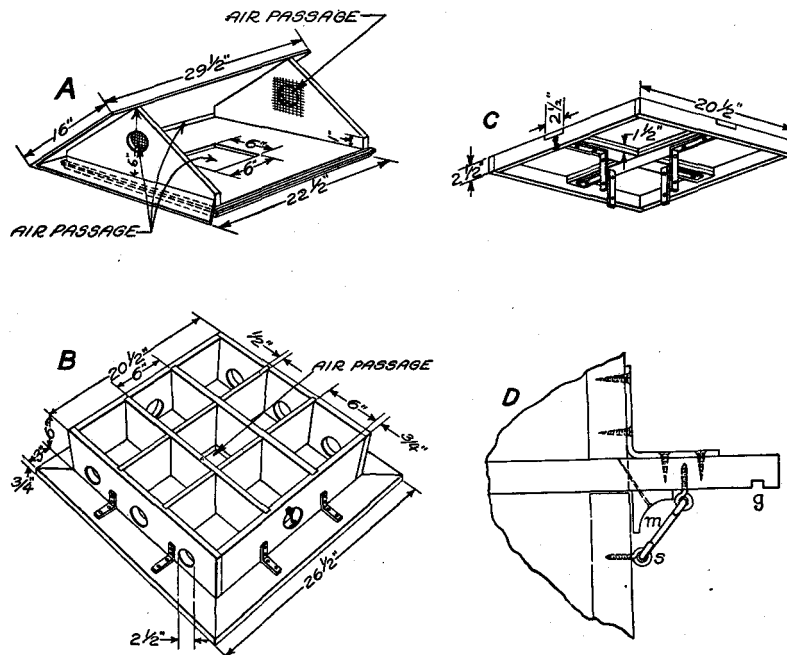

FIG. 6.—Details of the martin house shown in Figure 5: *A*, Roof with one side removed to show central air shaft. Air also passes through a 1-inch slot under the eaves and through two screened holes in the ends. *B*, One of the stories. The chambers are 6 by 6 by 6 inches inside dimensions, and the bottom of the central chamber is cut out. *C*, Foundation, in which the central cross is built up of double thicknesses of three-fourths-inch oak and the rest of the frame is of three-fourths-inch pine. Four heavy angle irons fasten this to the supporting pole. *D*, Detail of the porch when attached with angle irons; the molding *m* fits about the top of the lower story; the screw eyes and hooks *s* fasten the units together, and the groove *g* is made to prevent water from draining inward.

The material for the walls and floors should be three-fourths inch thick, and that for the roof and interior partitions should be one-half inch. A light-weight roofing paper cut into shingles makes an efficient and neat roof covering. When facilities for gluing are available, the 3-inch porches may be made as extensions of the floors; otherwise they may be attached with angle irons as illustrated.

Song sparrows.—Although a thicket usually affords all the necessities for their housekeeping, song sparrows may at times be induced to take up their abode in a more artificial location. A covered nest shelf, as in Figure 3, *A*, of weathered lumber, or painted

a somber hue to harmonize with the background, is advised, and should be placed in the bird's natural haunts.

House finch.—The house finch takes readily to homes of simple design and construction. Any of those pictured in Figure 1 will answer the purpose. Orchards or dooryards abounding in shrubbery, where brilliant sunshine alternates with cool shadows, are the house finch's favorite habitat. Nest boxes may be placed in trees or on posts or may be attached to buildings.

Starling.—European starlings readily avail themselves of artificial nesting facilities, and in areas where they are common their needs and their persistent efforts toward taking possession of what they

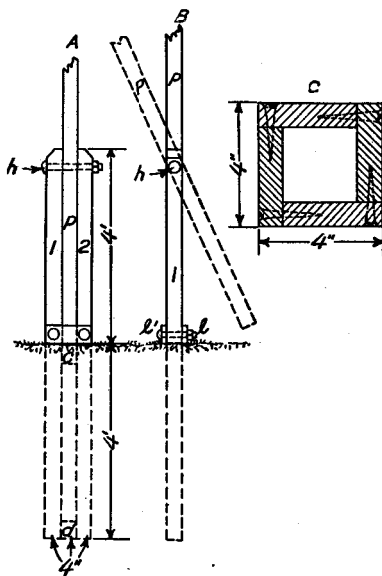

FIG. 7.—Martin-house pole. *A* and *B*: The supports (1 and 2) are 8 feet long and 4 inches square. They are held in alignment by the 4-inch blocks *c* and *d* and are buried 4 feet in the ground. A heavy bolt or section of pipe (*h*) serves as a hinge, and the base of the pole is held in position by the two hardwood blocks or iron plates (*l* and *l'*) bolted together. *C*: Cross-section of pole built of seven-eighths-inch hardwood. In case of large houses the pole and supporting posts should be 6 inches in outside diameter.

return to it from year to year. Away from this favorite environment, nesting sites in the shape of mere shelves, as illustrated in Figure 3, *C*, may be offered. These may be placed on the wall just within the large open doorway of the barn, or higher along the rafters, and even outside beneath the eaves, where protection may be had from above. In more exposed situations nest shelters, such as are pictured in Figure 3, *A* and *B*, may be used.

Crested flycatcher.—Very different from the phoebe's are the needs of its relative, the crested flycatcher, whose original nesting sites were old woodpecker holes and natural cavities in trees. For these

want must be given consideration. Houses made of lumber are just as acceptable to them as those of rustic design. Well-shaded sites are preferred, an old apple orchard being ideal from the starling's viewpoint. Although these birds are extremely wary, they show a marked preference for close association with human habitations during the breeding season. For this reason boxes erected in the dooryard are frequently occupied, though their presence there is usually rendered obnoxious by the rather careless housekeeping methods of these birds as the nestlings grow older. Boxes for starlings should be readily accessible for cleaning, an operation which is usually needed after the brood leaves. Two and sometimes three broods are reared. Any of the nest boxes pictured in Figure 1, when built of the proper size, are acceptable.

Phoebe.—The phoebe, in common with certain other highly insectivorous birds, shows a liking for the vicinity of bodies of water. The broad timbers beneath a bridge are always an attraction, and when once a pair has taken up their abode in such a situation they are certain to

holes there may now be substituted boxes made of weathered or dull-painted lumber or fashioned from natural stubs or slabs. The latter types, when placed in typical situations, as in orchards, open woodland, or in trees in pastures, probably have a greater appeal than homes made of lumber. (See figs. 1 and 2.)

Woodpeckers.—Of all the woodpeckers, flickers respond most readily to the lure of artificial nest boxes. These birds have no hesitation in using boxes of painted or weathered lumber if other conditions are satisfactory. Boxes built to proper dimensions and conforming to any of the types illustrated in Figure 1 are acceptable. A roughened interior is preferable to a smooth one, as it permits the young to clamber up to the entrance as they grow older. A quantity of coarse sawdust, ground cork, or better, small chips, should cover the bottom of the box to the depth of 1 or 2 inches, in order that the birds may shape a cavity for the eggs. The chips also assist the birds in keeping the nest clean. Should these be neglected the birds are likely to mutilate the box in their efforts to produce their own supply. Flicker boxes should be placed above any immediately surrounding foliage. A dead stub makes an excellent support for the box and even a pole of the desired height will serve the purpose. The erection of flicker boxes may be used to prevent damage by these birds, especially the western form, which often persist in drilling holes into buildings in attempting to excavate a nesting site.

The red-headed woodpecker, although preferring nest holes of its own manufacture, has been known to occupy man-made homes, those fashioned from a natural stub being most acceptable (fig. 2, *D*). Bark-covered boxes (fig. 2, *A* and *E*) also will serve the purpose. As in the case of flicker houses, these should be placed above the immediately surrounding foliage. These birds are especially partial to oak groves. They are prone also to drill holes in telephone poles, which may cause the latter to break in windstorms. Supplying nest boxes will afford some protection to the poles.

The needs of the downy and hairy woodpeckers are similar and vary only in the slight difference of the size of nest cavity and entrance. Boxes of the types shown in Figure 1, covered with bark or made from natural stubs or slabs (fig. 2), are needed. In the bottom of each should be placed a small quantity of fine chips. A bit of open woodland, or even the orchard, will furnish a desirable site for their nests, and these should be attached to the trunk of a tree not densely shaded.

Owls.—Screech owls are not at all averse to using nesting facilities provided by man. Boxes of the types illustrated in Figure 1, when made of weathered lumber and stained a dull color or covered with bark, are acceptable. A grove, or, even better, an apple orchard, furnishes excellent sites for screech-owl boxes. The birds will supply the few bits of wood and feathers needed to form a nest. It should be noted that in some instances screech owls have proved very destructive to other birds during the nesting season, but this is not believed to be true of the saw-whet and barn owls.

The little saw-whet owl will take more readily to nest boxes fashioned from logs or those given a rustic appearance by a layer of

bark (fig. 2). Chances are best for occupancy when the box is fastened to a substantial tree in an open grove.

The barn owl, now rare throughout much of its former range, may still be found in numbers locally. It takes readily to man-made structures, often frequenting barn lofts and towers on buildings for the nesting operations. A simple wooden box (fig. 1) of the proper dimensions will answer this owl's needs, and the birds will furnish the scanty nest material used. These boxes may be attached to the trunks of rather large trees or may be located about barn cupolas or in other little-frequented spots about buildings. For

many years a pair of barn owls nested in one of the towers of the Smithsonian Institution, at Washington, D. C., in the center of an extensive park system.

Wood duck.—With the continuous cutting of the older stands of timber, nesting sites for the wood duck are becoming increasingly scarce. To encourage the return of these beautiful ducks nothing more important can be done than the furnishing of nest boxes. These may be made of weathered lumber and fastened to the trunks of substantial trees. Any of the designs in Figure 1, if made

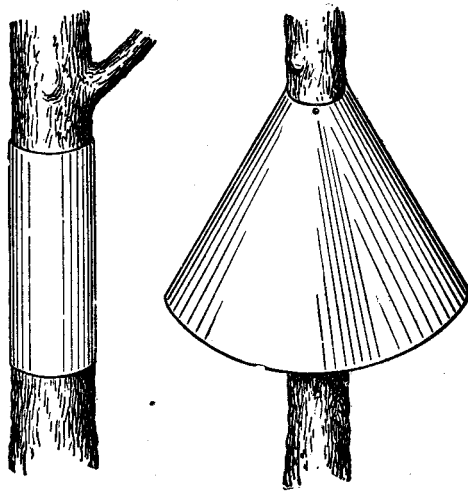

FIG. 8.—Tree guards

to the proper dimensions, are satisfactory. Even an ordinary nail keg with a suitable opening has served well as a wood-duck abode. Lowland timber not far from a shady stream is the wood-duck's favorite breeding ground.

PROTECTION AGAINST ENEMIES

CATS

The house cat is one of the greatest obstacles in efforts toward increasing bird life in urban or suburban communities. The mere presence of a cat, regardless of whether it is or is not a habitual bird killer, has a demoralizing effect on nesting birds and may entirely defeat the most energetic efforts to attract and increase their numbers. Young birds just out of the nest are the easiest prey for the house cat and are liable to arouse the predatory instincts of the most docile and well-mannered. During the nesting season even the well-trained house cat must be kept away from the vicinity of bird houses, and the vagrant animal must be carefully guarded against or dealt with summarily.

A bird house placed on a pole or in a tree may be made inaccessible to cats by use of a sheet-metal guard. This may be either a cylinder about 18 inches long tacked closely to the trunk, or a cone, as pic-

tured in Figure 8, placed high enough to prevent cats from springing from the ground and securing a hold above it. Iron pipes as nest supports are cat-proof in themselves. A far-overhanging and sloping roof close over the nest opening also is a partial protection against cats. In some situations, wire screen of a mesh large enough to permit the passage of the bird may be used to inclose the box in such a way as to prevent cats from reaching the nest. A more effective but expensive protection involves the use of vermin-proof fences built of strongly woven wire of not more than 1½-inch mesh. Such a fence should be about 6 feet high with an outward overhang of 2 feet at the top (fig. 9).

Vagrant cats secure much of their food during spring and summer from bird life and had best be eliminated. In thickly settled regions poisoning or shooting are not recommended, but traps can be used effectively.⁹

SQUIRRELS AND MICE

White-footed mice and squirrels, particularly red squirrels, at times become troublesome to nesting birds. Both eggs and young birds are

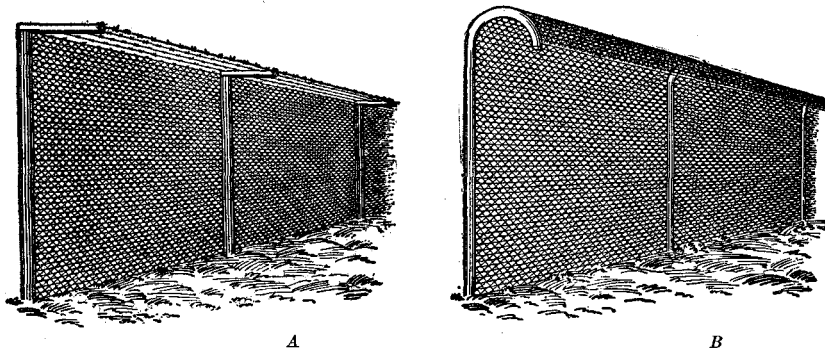

FIG. 9.—Cat-proof fences: A, With barbed wire; B, with overhanging netting

eaten, and in search for these the squirrels frequently enlarge the opening to the nest box. The tree-guards illustrated in Figure 8 will keep squirrels from ascending isolated trees or posts, and circlets of sheet metal placed around entrance holes will prevent them from entering boxes having openings that they must first enlarge. Some observers assert that these metal circlets make it difficult for birds to obtain a footing at the nest hole, but this objection can be overcome by fitting them on the inside. It is well also to see that the circlets have no sharp edges or jagged projections to injure the birds.

Houses suspended on wires beyond jumping range from solid objects are immune to attacks by squirrels, cats, and mice, and are occupied by some birds. Occasionally squirrels that are particularly troublesome have to be shot.

ENGLISH SPARROWS

The ubiquitous English sparrow, a source of no little exasperation to those seeking to attract our native birds, also must be discouraged. Wrens and chickadees can be supplied with boxes having entrances

⁹ Instructions for trapping cats are contained in Leaflet No. 50, How to Make a Cat Trap.

less than 1¼ inches in diameter, too small for the passage of an English sparrow. Competition of the sparrow with other hole-nesting species can be prevented effectively only by a reduction in its numbers. Persistent destruction of their nests will discourage these birds, but at the slightest relaxation in vigilance they will reestablish themselves. When sparrows have taken up an abode in a bird house the female may be caught by closing the entrance during the night. Solution of the difficulty, however, lies in an aggressive campaign against the sparrow, carried out preferably during the winter months, with the object of materially reducing or eliminating the breeding population for the next season.¹⁰

EUROPEAN STARLINGS

The European starling presents a somewhat similar problem in the eyes of those who look upon the bird mainly in the light of its transgressions against our native species. This bird is extremely persistent when engaged in a controversy over the ownership of a nesting site and seldom fails to be the victor. Its insectivorous habits, however, place it in the van of those birds that are considered effective controlling agencies of ground insect pests. When not too abundant, starlings are a distinct asset about the garden, and it will pay to provide nest boxes for their use (see p. 14).

HOUSE WRENS

Although they are so praiseworthy as to food habits, house wrens sometimes interfere seriously with the nesting operations of other birds, even to the extent of puncturing and thus destroying their eggs. It is possible that these little busybodies have received too much encouragement in some localities. Where trouble is observed between them and other species of birds that it is desired to foster, bird houses suitable for wrens only can be reduced in number, or, if necessary, removed entirely.

OTHER ENEMIES

Red-headed woodpeckers, blue jays, purple grackles, magpies, crows, and other birds occasionally destroy eggs and young to an obnoxious extent. When the offending bird is not protected by Federal or State laws, the remedy is elimination by shooting.

SANITATION OF BIRD HOUSES

The desirability of having all bird houses built so as to be readily opened for inspection has been noted previously. This feature is a necessity in regions infested by the gipsy moth, as all possible hiding places for the egg masses of this species must be examined. The tussock moth and other insect pests also may place their eggs or cocoons in bird houses; and it will be to the advantage of the owner as well as of the birds if the boxes are regularly inspected and cleansed of all intruders, which include also mud-daubers and paper-wasps, bees, mice, and flying squirrels. The insects can be stupefied by fumes of carbon disulphide, carbon tetrachloride, sulphur, ordi-

¹⁰ Methods of combating these birds by trapping and poisoning are to be found in Leaflet 61, English Sparrow Control.

nary smoke, or the like, and disposed of as desired. The small rodents can be dumped out unceremoniously in the hope that the birds will take possession before they return; or, if it seems necessary, they can be killed.

The houses should be repaired and cleaned just before the nesting season and inspected periodically so long as birds are about. Birds are subject to parasites, some of which, as fleas, bird lice, and bird flies, are usually mere nuisances; but others, as the larvae of certain flesh flies, are a serious menace to nestlings and sometimes are so prevalent as to cause general mortality over a considerable area. Houses infested by these pests may be treated with liberal applications of derris or pyrethrum powder, special attention being given to the nest. The feathers of nestlings also can be powdered. In case the fly larvae are discovered in time, any that are actually attached to the nestlings may be removed and a mild antiseptic applied to the wounds.

It is advisable to clean nest boxes immediately after broods have left, even if the parent birds show signs of using the house for another family. Old eggs and dead nestlings will thus be gotten rid of and the parasites of the birds kept down. The material removed should be placed on a paper and burned. After cleaning, spray the interior well with cresol to destroy any pests that may have been overlooked. On the whole, clean nest boxes have a better chance of being occupied, and certainly the prospects for rearing the next brood are improved.

So far as bird parasites are concerned sanitation of the houses can be profitably supplemented by ample provision for water and for dust or sand baths.¹¹ These are nature's means of keeping down body vermin.

PROVISION OF NESTING MATERIAL

The home making of birds can be aided in many cases by the provision of nesting material. Natural materials of some sorts are not so abundant as formerly, and substitutes are welcome. Rags, ravelings, and twine can be used by many birds, but short pieces only should be furnished in order to avert danger to the birds from tangling. Excelsior, straw, hay, cotton, and even hair (as used in plastering) and feathers may be supplied. A convenient way of exposing these to the birds, which at the same time prevents waste, is to use holders similar to those in which suet is placed for winter feeding; an ordinary wire broiler is excellent for the purpose. If thoroughly wet clay be made available, it will be eagerly taken by robins, phoebes, and swallows.

NESTING THICKETS

Besides the birds that build their nests on the twigs or limbs of trees, in cavities of the trunk, or in nest boxes placed in trees, there are others that can be helped by providing thickets similar in character, if not in size, to those they naturally frequent. Density seems to be the most desirable feature of a bird thicket, as it gives protec-

¹¹ For information on bird baths see the Farmers' Bulletin mentioned in footnote 3, page 2.

tion from enemies. Shrubs interlaced with vines are effective and rather easily provided. In their earlier years the shrubs should be pruned so as to form numerous crotches that will support nests. The kinds of plants to use depend upon the locality; but those producing fruit eaten by the birds are most desirable, as they serve a double purpose. Recommendations as to the species suitable for various sections of the United States are contained in Farmers' Bulletins mentioned in footnote 3 on page 2.

ROOSTING SHELTERS

Compared with those interested in bird protection in central Europe, Americans have sadly neglected one important matter in bird conservation—the provision of suitable roosting quarters, which have great value during periods of cold weather. The nest boxes

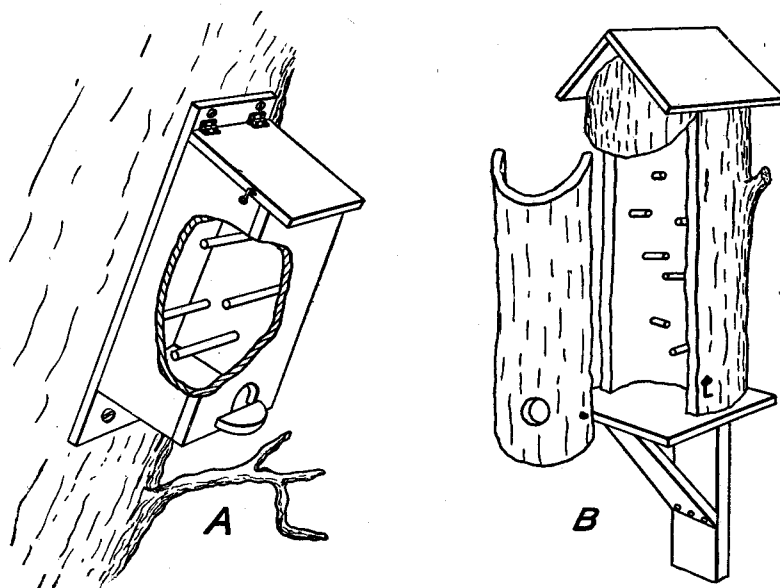

FIG. 10.—Roosting shelters that will serve as a much-needed protection during severe weather, particularly for winter birds

left up throughout the year fill this need in part, but much more can be done. The removal of thickets and hollow trees in which numbers of birds formerly sought refuge from the elements and from enemies has greatly increased the need of warm and safe quarters for inclement nights. A large hollow tree partitioned into apartments may become the haven for a number of birds belonging to several species, as was demonstrated some years ago in an interesting manner when a well-known naturalist constructed an artificial hollow tree, to which he would often repair to study the ways of the nightly visitors. Although nothing so pretentious as this is necessary to fill the needs of roosting birds in a community, there is no question that proper housing will greatly reduce the winter mortality among them. Woodpeckers, titmice, nuthatches, chickadees, wrens, starlings, and owls will readily avail themselves of such

shelters, and doubtless many species not hole nesters would use such cavities as roosting places. The benefits accruing from the provision of roosting shelters may not be so apparent as in the case of nest boxes, but they are none the less real. Several of our woodpeckers, chickadees, nuthatches, and titmice now have the habit of using old nests for winter quarters, and no doubt they will utilize nest boxes or roosting houses for the purpose, especially such of the latter as are constructed for individual birds.

Roosting boxes should be waterproof and firmly attached to their supports. Placed at an average height of 8 or 10 feet, with a southerly exposure for the entrance, they will meet the needs of most birds. They may well be located in a sheltered spot to give added warmth, and should have the customary cat and squirrel guards in areas where these animals are apt to be troublesome. Contrary to the principles of nest construction, the entrance need not be near the top. A lower entrance (fig. 10), in fact, will have a tendency to let what warmth accumulates rise and be retained at the top. The perches within should be arranged so that none is directly over another. Such roost boxes may be of variable size, but one 8 or 10 inches square and 3 feet long will provide shelter for several small birds. Two suggestions along this line are given in Figure 10. An entrance hole 3 inches in diameter will meet the needs of the smaller birds, while owls are better cared for by supplying individual boxes with larger openings. Sanitation should follow the lines laid down for nest boxes (pp. 18-19).

**ORGANIZATION OF THE UNITED STATES DEPARTMENT OF AGRICULTURE
WHEN THIS PUBLICATION WAS LAST PRINTED**

<i>Secretary of Agriculture</i>	HENRY A. WALLACE.
<i>Under Secretary</i>	REXFORD G. TUGWELL.
<i>Assistant Secretary</i>	M. L. WILSON.
<i>Director of Extension Work</i>	C. W. WARBURTON.
<i>Director of Personnel</i>	W. W. STOCKBERGER.
<i>Director of Information</i>	M. S. EISENHOWER.
<i>Director of Finance</i>	W. A. JUMP.
<i>Solicitor</i>	SETH THOMAS.
<i>Agricultural Adjustment Administration</i>	CHESTER C. DAVIS, <i>Administrator</i> .
<i>Bureau of Agricultural Economics</i>	NILS A. OLSEN, <i>Chief</i> .
<i>Bureau of Agricultural Engineering</i>	S. H. McCRORY, <i>Chief</i> .
<i>Bureau of Animal Industry</i>	JOHN R. MOHLER, <i>Chief</i> .
<i>Bureau of Biological Survey</i>	J. N. DARLING, <i>Chief</i> .
<i>Bureau of Chemistry and Soils</i>	H. G. KNIGHT, <i>Chief</i> .
<i>Office of Cooperative Extension Work</i>	C. B. SMITH, <i>Chief</i> .
<i>Bureau of Dairy Industry</i>	O. E. REED, <i>Chief</i> .
<i>Bureau of Entomology and Plant Quarantine</i> ..	LEE A. STRONG, <i>Chief</i> .
<i>Office of Experiment Stations</i>	JAMES T. JARDINE, <i>Chief</i> .
<i>Food and Drug Administration</i>	WALTER G. CAMPBELL, <i>Chief</i> .
<i>Forest Service</i>	FERDINAND A. SILCOX, <i>Chief</i> .
<i>Grain Futures Administration</i>	J. W. T. DUVEL, <i>Chief</i> .
<i>Bureau of Home Economics</i>	LOUISE STANLEY, <i>Chief</i> .
<i>Library</i>	CLARIBEL R. BARNETT, <i>Librarian</i> .
<i>Bureau of Plant Industry</i>	FREDERICK D. RICHEY, <i>Chief</i> .
<i>Bureau of Public Roads</i>	THOMAS H. MACDONALD, <i>Chief</i> .
<i>Weather Bureau</i>	WILLIS R. GREGG, <i>Chief</i> .