

University of Nebraska - Lincoln

DigitalCommons@University of Nebraska - Lincoln

Conference Presentations and White Papers:
Biological Systems Engineering

Biological Systems Engineering

2010

Effect of Magnetron Frequency on Heating Pattern in Domestic Oven

Sohan Birla

University of Nebraska- Lincoln, sbirla2@unl.edu

Krishnamoorthy Pitchai

University of Nebraska-Lincoln

Jeyamkondan Subbiah

University of Nebraska-Lincoln, jeyam.subbiah@unl.edu

David D. Jones

University of Nebraska-Lincoln, david.jones@unl.edu

Follow this and additional works at: <https://digitalcommons.unl.edu/biosysengpres>



Part of the [Biological Engineering Commons](#), [Bioresource and Agricultural Engineering Commons](#), and the [Electrical and Computer Engineering Commons](#)

Birla, Sohan; Pitchai, Krishnamoorthy; Subbiah, Jeyamkondan; and Jones, David D., "Effect of Magnetron Frequency on Heating Pattern in Domestic Oven" (2010). *Conference Presentations and White Papers: Biological Systems Engineering*. 54.

<https://digitalcommons.unl.edu/biosysengpres/54>

This Article is brought to you for free and open access by the Biological Systems Engineering at DigitalCommons@University of Nebraska - Lincoln. It has been accepted for inclusion in Conference Presentations and White Papers: Biological Systems Engineering by an authorized administrator of DigitalCommons@University of Nebraska - Lincoln.



**INTERNATIONAL MICROWAVE
POWER INSTITUTE'S
44TH ANNUAL SYMPOSIUM**

2010 PROCEEDINGS



ISSN: 1070-0129

Effect of Magnetron Frequency on Heating Pattern in Domestic Oven

Sohan Birla, Krishnamoorthy Pitchai, Jeyamkondan Subbiah, David Jones

Department of Biological System Engineering, University of Nebraska- Lincoln

ABSTRACT

In this study a computer model was developed to simulate microwave heating of a model food with a range of magnetron frequencies. The range was decided upon performing the frequency spectrum analysis of microwave leakage from the microwave oven. Simulation results showed that the magnetron input as sinusoidal frequency from 2.44 GHz to 2.48 GHz generates different heating profiles. The simulated heating profiles were compared with experimental heating profiles obtained by using an IR camera. None of simulations with individual frequency exactly matches with experimental temperature profile. The closest match between simulated and observed temperature profiles was found with 2.46 GHz frequency. This study helped us to understand the dynamic nature of magnetron and how it influences microwave heating pattern of any food materials.

Key words: Microwave heating, non-uniformity, modeling, frequency spectrum

INTRODUCTION

Microwave ovens are commonly used for reheating and cooking just before consumption, hence microwave heating must assure food safety. The food safety problem in foods is primarily an engineering problem rather than a microbiological issue. It is critical to have an understanding of how microwaves interact with food components in domestic microwave ovens to solve this problem.

Chan and Reader (2000) have been instrumental in developing an understanding of electric field distribution in multimode domestic oven cavity. In the past, researchers have made one or more assumptions to simplify the problem and to minimize the computational time in simulation. For example, instead of modeling Maxwell's equation, several researchers simplified the problem by using Lambert's law, which calculates dissipated power by simple expression assuming that the power decays in the food exponentially (Campañone and Zaritzky, 2005; Chamchong and Datta, 1999). Few models have been reported that couple electromagnetic and thermal model (Geedipalli et al., 2007; Wäppling-Raaholt et al., 2002; Zhang and Datta, 2003).

So far, researchers have assumed that a microwave oven is a simple cavity in which one port is located at certain place and microwave is fed at fixed frequency. A close look into the intricacy of the modern oven design hints that the design of the microwave oven has lot more to consider in simulation results intended for predicting a correct temperature profile. For example, the microwave power source, a magnetron, is an imperfect device –which changes its frequency during the heating, and it may even "jump" from one frequency to another. The instantaneous frequency emitted by a magnetron in a microwave oven depends on two parameters: The cathode-anode voltage and the high frequency output impedance of the magnetron which is set by the load (Ghammaz et al., 2003). Therefore a magnetron does not generate microwave at fixed frequency but a range of band 2450 ± 50 MHz (Risman, 2009). A change in the load temperature modifies electric properties of it, thus detuning the cavity. This means powder delivered to the cavity by the magnetron will change by the load condition over the heating time. The detuning will not only change the heating rate but also change the field distribution through a change of the operating frequency (Celuch and Kopyt, 2009).

In this paper, we present model development that includes all details of modern microwave oven geometry and study the effect of magnetron frequency on heating patterns in a domestic microwave oven. This study will enable us to understand complexity of microwave heating.

MATERIALS AND METHODS

Governing Equations

Microwave heating of food items involves internal heat generation by interaction of microwaves with food materials and diffusion of the heat within and outside the materials.

Electromagnetic

Water and ions are primary food components that absorb microwaves, leading to volumetric heating. The volumetric heating rate, or the power absorption of the microwave Q , is related as:

$$Q = 2\pi f \epsilon_0 \epsilon'' E^2 \quad \text{Eq. (1)}$$

where f is microwave frequency (Hz), ϵ_0 is the permittivity of free space, ϵ'' is the dielectric loss factor of the material, and E is the electric field strength (V/m). Solutions for electric fields for Eq. 1 requires to solve electromagnetic wave Eq. 2 which is derived from the set of Maxwell's equations (Datta and Anantheswaran, 2001):

$$\nabla \times \frac{1}{\mu} \nabla \times E - \omega^2 \epsilon^* E = 0 \quad \text{Eq. (2)}$$

where, μ is the permeability, ϵ^* is the relative complex permittivity of the material, and expressed as $\epsilon' - j \epsilon''$ in which ϵ' is the dielectric constant of the material, ω is the angular frequency ($2\pi f$).

Perfect electric conductor boundary conditions were set on the walls of the oven cavity and waveguide. The input port boundary condition on the rectangular waveguide end was assigned as TE₁₀ mode. Procedure to determined values of amplitude of the electric field intensity at the port and magnetron frequency is determined in subsequent section.

Heat Transfer

The dissipated heat diffused by conduction inside the material is governed by the Fourier unsteady state equation:

$$\rho c_p \frac{\partial T}{\partial t} = \nabla \cdot (k \nabla T) + Q \quad \text{Eq. (3)}$$

where T is the temperature at a position x and time t , ρ is density, c_p is specific heat, k is thermal conductivity.

Model Development Steps

Geometric Model Development

Geometric model of a microwave oven (Sharp carousel II) was created considering all the details such as crevices, dimples and bumps in the waveguide, and waveguide port configuration as shown in Fig. 1. Quickwave software (QWED 7.5 v SP, Poland) was used to simultaneously solve Eqs. 1-3 for predicting temperature profile.

Input Power

In a microwave oven, the magnetron feeds the waves in the oven cavity through a waveguide. The output power and frequency of a magnetron depend on the impedance of the heating load. It is essential to know the power output of a magnetron for providing correct input electric field amplitude at the wave port. The power output of magnetron was determined by using IEC 60705 standard method with 1000 and 250 g water load. The microwave input to the cavity is proportional to the square of the modulus of the electric field intensity. The electric field intensity amplitude was estimated by taking the square root of the double of power absorbed in the 250 g water load.

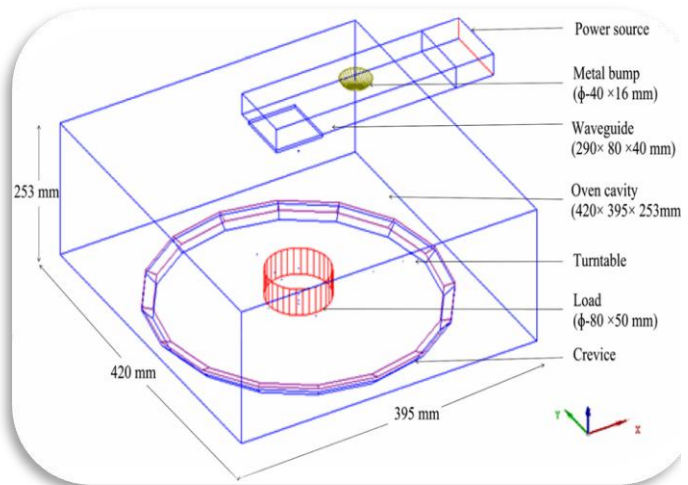

Fig. 1 Geometric model of microwave oven

Frequency spectrum measurement

Magnetron frequency spectrum was determined by the analysis the microwave leakage while microwave oven was heating a gellan gel cylindrical load. The leakage signal was captured on a double-ridged waveguide horn antenna (EMCO 3115, Advanced Test Equipment Corp, San Diego) connected a spectrum analyzer (ESIB 26, Rohde and Schwarz Inc., Munich). The microwave oven was kept on a turntable to facilitate capturing leakage from all sides on the antenna by the horn positioned one meter away. The set was kept in a large anechoic chamber as shown in Fig. 3. Based on the frequency spectrum a range of frequencies were used in simulation of microwave heating of gellan gel cylinder.

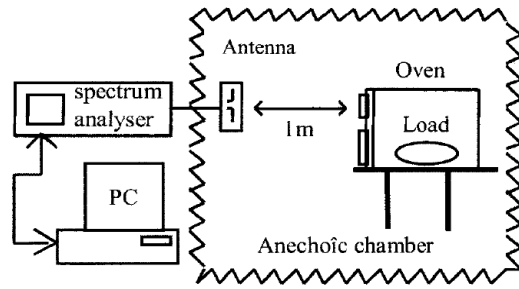

Fig. 3. Set up for magnetron frequency determination

Solution Strategy

The geometric model was discretised with hexahedral conformal cells. Mesh optimization is a very important step in obtaining meaningful simulation results. In this study we simulated MW heating with 5, 3, 2 and 0.5 mm mesh sizes to check the level of the discretisation error. The cells were made smaller where large EM field gradient was expected, for example, waveguide, gellan gel and turntable. Based on this study 5 mm mesh size in air domain and 1 mm mesh size in load and turntable were found to yield mesh independent simulation results. In a simulation domains containing 4,409,845 elements took 6-7 hours on Dell Precision 690 workstation (8 GB RAM, dual Intel Xeon Processor@2.33 GHz).

Model Validation

Model food preparation

One percent gellan gum powder (Kelcogel, Kelco Division of Merck and Co., San Diego, CA) was dissolved in deionized water and the solution was heated to 90°C in 15 min. CaCl₂ Salt 0.17% was added into the hot gellan gum solution to adjust the loss factor and form stable gel. Hot gel solution was poured into a round plastic container (80 × 50 mm) and allowed to cool at room temperature for 30 min to ensure gel setting (Birla et al., 2008). The prepared gel samples were stored at ~4°C in a closed container. Physical and thermal properties of the gel were estimated using Choi and Okos model (1986) and summarized in Table 1. Temperature dependent dielectric properties of the gel were measured using the open coaxial probe method. The regression equations shown in Table 1 were used in the simulation.

Table 1 Properties of materials used in simulation

Properties	Gellan gel	Quartz turntable
Thermal conductivity, w/m/K	0.53	1.1
Density, kg/m ³	1010	2250
Specific heat, J/kg/K	4100	2080
Dielectric constant	$-0.28T + 80.21$	6
Loss factor	$-6E-05T^3 + 0.0114T^2 - 0.612T + 20.8$	0.10

Experimental procedure

The fiberoptic sensors (FOT, FISO Technologies Inc, Quebec) were inserted at four different points inside a gel cylinder to record the transient temperature (Fig. 2). The cylinder was kept in the center of the stationary quartz turntable. Immediately after 30 s of heating, the thermal images of the top, middle and bottom layers of gel cylinder were recorded using an infrared imaging camera (SC 640, FLIR systems, Boston).

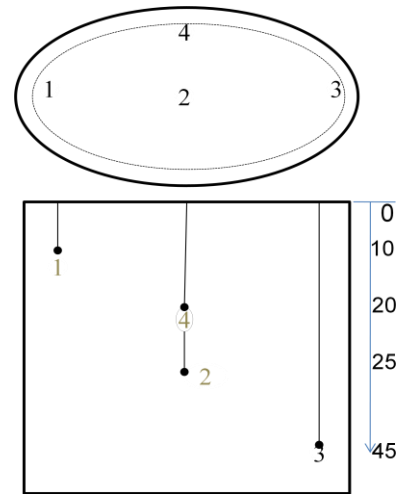

Fig. 2 Location of sensors

RESULTS

Magnetron power and frequency

Microwave power output determined by IEC 60705 method was 629 ± 24 W, whereas for 250 g water load power absorption was 529 ± 28 W. Assuming similar power is absorbed by the gel cylinder, the electric field intensity amplitude was estimated to be 32.52 V/m. This value is valid when there is no reflection back to magnetron and no cavity losses. To take these into account, we determined the scattering parameter, S_{11} from frequency range 2.4 to 2.6 GHz. Fig. 4 shows that for the gellan gel cylinder deep resonance will occur at magnetron frequency 2.46 GHz. Even at deep resonance, there will be 38% power reflected back to the magnetron. Hence the electric field amplitude value was increased to 35 V/m to match up with experimental temperature profile.

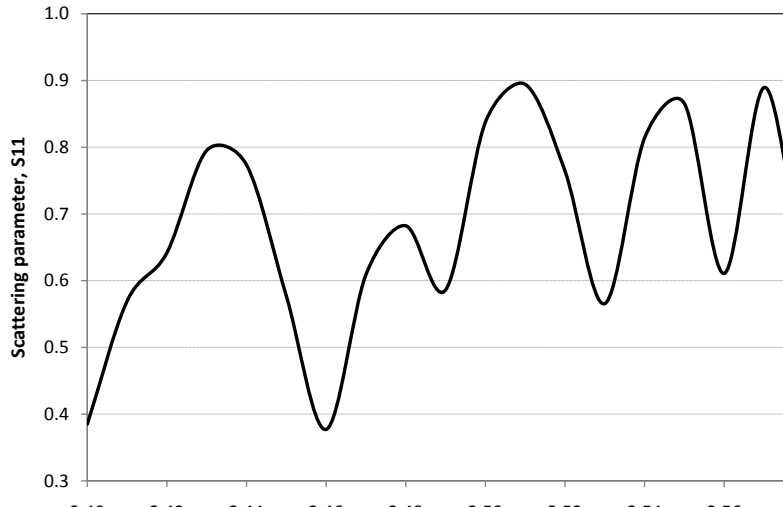

Fig. 4 Simulated scattering parameter S_{11} at various frequencies of magnetron

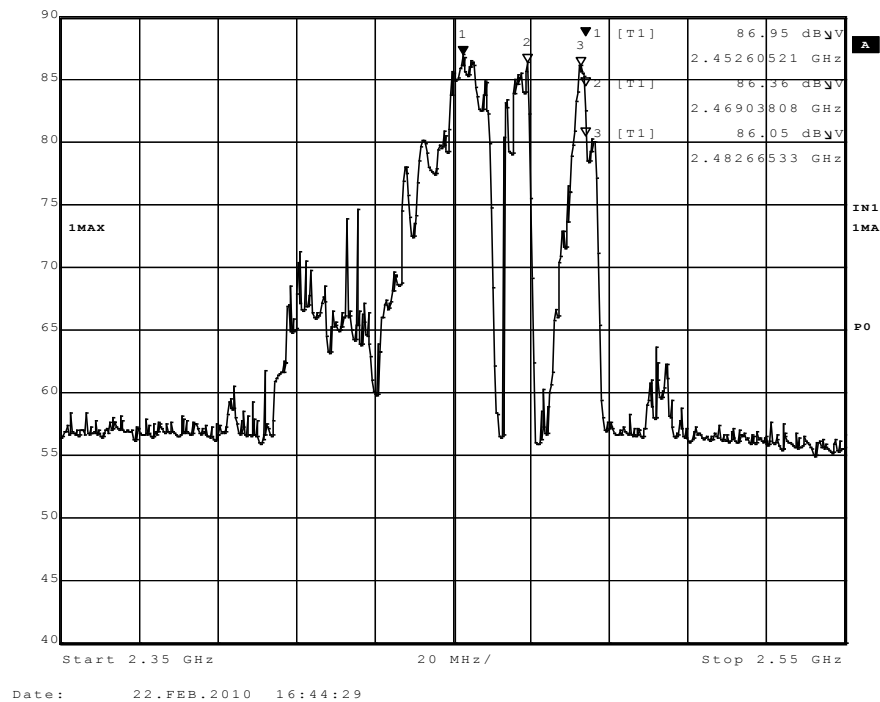

Fig. 5 Frequency spectrum of microwave oven

For determining magnetron frequency, microwave leakage was captured on the horn antenna connected with the spectrum analyzer. Fig. 4 shows frequency distribution indicating three peaks around 2.45 and 2.47 and 2.48 GHz in Max hold condition. It is quite evident that magnetron does not generate one frequency but a bandwidth spanning from 2.4 to 2.5 GHz. Hence the microwave simulation with one particular frequency may not represent the real case.

Effect of magnetron frequency on heating pattern

Fig. 7 shows the simulated and experimental temperature profile at the top, middle and bottom plane of the cylinder at three magnetron frequencies. The thermal images of middle layer seem to agree well qualitatively with the simulated profiles. The most significant effect of the frequency is observed on the top layer of the cylinder. This was also corroborated with temperature profiles recorded and simulated as shown Fig. 6. The sensor #1 located on the top was way off at all the simulated frequencies, whereas other three were in close agreement.

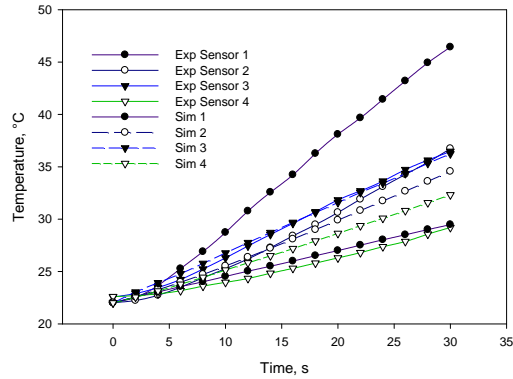

Fig. 6 Simulated and experimental temperature history

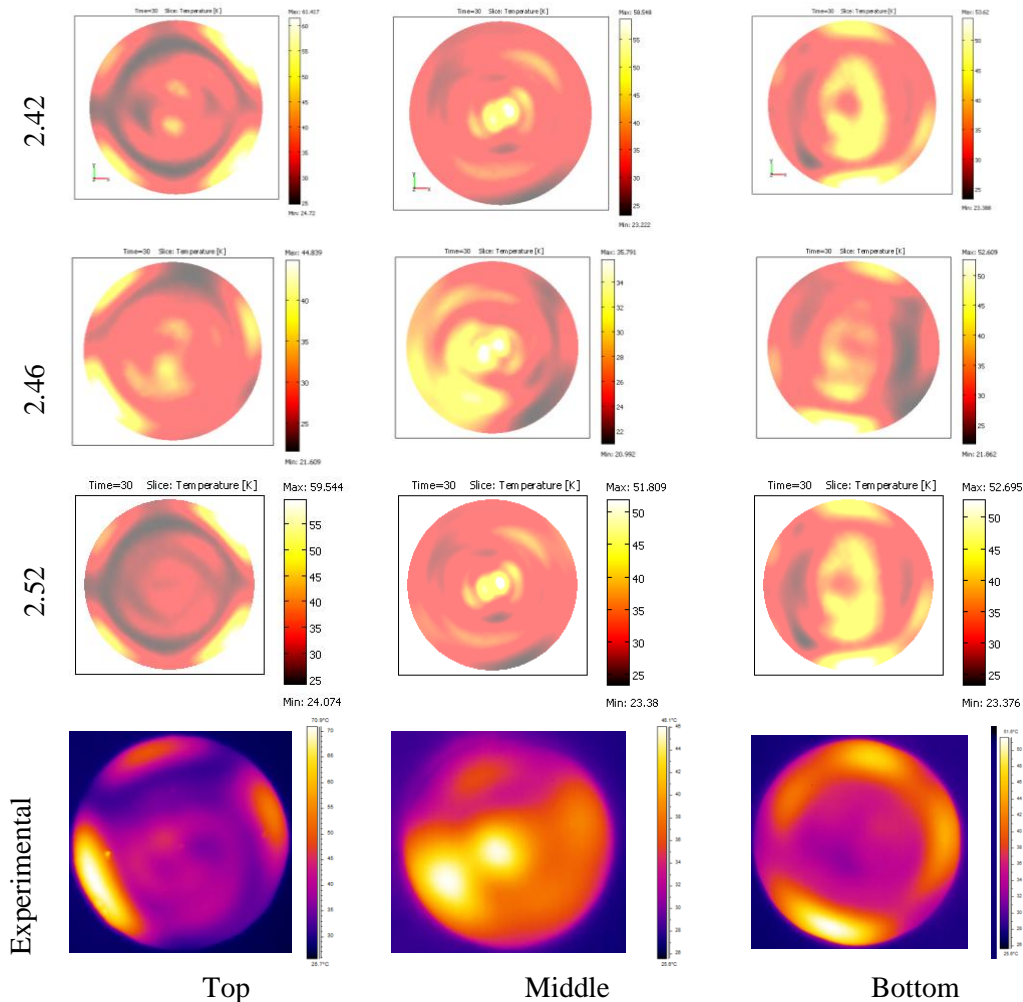

Fig. 7 Comparison of simulated and experimental temperature profile at 2.42, 2.46 and 2.52 GHz frequencies

DISCUSSION

We have seen that each frequency has its own characteristic heating pattern; hence, input of microwave energy in form of frequency spectrum will result in combined effect of these frequencies. Our next approach will be simulating power distribution with three dominant frequencies identified from the magnetron frequency analysis and take the weighted average of the power density at each element at each time steps. We are also conducting simulation studies to find the exact magnetron power delivered to cavity and losses in the cavity.

ACKNOWLEDGEMENT

This research was supported by a USADA NIFSI grant. We sincerely acknowledge the technical support provided by Dr. Andrzej Wieckowski, QWED Spz, Warsaw, Poland for using QWED software. Authors are thankful to Nebraska Center for Excellence in Electronics lab for helping in frequency spectrum analysis.

REFERENCES

- Birla, S. L., S. Wang, J. Tang, and G. Tiwari. 2008. Characterization of radio frequency heating of fresh fruits influenced by dielectric properties. *Journal of Food Engineering* 89: 390-398.
- Campañone, L. A., and N. E. Zaritzky. 2005. Mathematical analysis of microwave heating process. *Journal of Food Engineering* 69: 359-368.
- Celuch, M., and P. Kopyt. 2009. Modeling microwave heating in foods. In: M. W. Lorence and P. S. Pesheck (eds.) *Development of packaging and products for use in microwave ovens*. p 408. Woodhead Publishing Limited, Cambridge, UK.
- Chamchong, M., and A. K. Datta. 1999. Thawing of foods in a microwave oven: I. Effect of power levels and power cycling. *Journal of Microwave Power and Electromagnetic Energy* 34: 9-21.
- Chan, T. V. C. T., and H. C. Reader. 2000. *Understanding microwave heating cavities*. 2 ed. Artech House, London.
- Choi, Y., and M. R. Okos. 1986. Effect of temperature and composition on the thermal properties of foods. In: M. LeMaguer and P. Jelen (eds.) *Food engineering and process applications*. p 93. Elsevier Applied Science Publishers, New York.
- Datta, A. K., and R. C. Anantheswaran. 2001. *Handbook of microwave technology for food applications*. M. Dekker, New York.
- Geedipalli, S. S. R., V. Rakesh, and A. K. Datta. 2007. Modeling the heating uniformity contributed by a rotating turntable in microwave ovens. *Journal of Food Engineering* 82: 359-368.
- Ghammaz, A., S. Lefevre, and N. Teissandier. 2003. Spectral behavior of domestic microwave ovens and its effects on the ism band. *Annals of Telecommunications* 58: 1178-1188.
- Risman, P. O. 2009. Advanced topics in microwave heating uniformity. In: M. W. Lorence and P. S. Pesheck (eds.) *Development of packaging and products for use in microwave ovens*. p 408. Woodhead Publishing Limited, Cambridge, UK.
- Wäppling-Raaholt, B. et al. 2002. A combined electromagnetic and heat transfer model for heating of foods in microwave combination ovens. *Journal of microwave power and electromagnetic energy* 37: 97-111.
- Zhang, H., and A. K. Datta. 2003. Microwave power absorption in single- and multiple-item foods. *Food and Bioproducts Processing* 81: 257-265.