

University of Nebraska - Lincoln

DigitalCommons@University of Nebraska - Lincoln

Nebraska Game and Parks Commission -- White
Papers, Conference Presentations, &
Manuscripts

Nebraska Game and Parks Commission

January 1977

Wood Duck Nesting Boxes

Dick Gersib

Wildlife Habitat Area Manager - Salt Valley

Follow this and additional works at: <https://digitalcommons.unl.edu/nebgamewhitepap>



Part of the [Environmental Sciences Commons](#)

Gersib, Dick, "Wood Duck Nesting Boxes" (1977). *Nebraska Game and Parks Commission -- White Papers, Conference Presentations, & Manuscripts*. 21.

<https://digitalcommons.unl.edu/nebgamewhitepap/21>

This Article is brought to you for free and open access by the Nebraska Game and Parks Commission at DigitalCommons@University of Nebraska - Lincoln. It has been accepted for inclusion in Nebraska Game and Parks Commission -- White Papers, Conference Presentations, & Manuscripts by an authorized administrator of DigitalCommons@University of Nebraska - Lincoln.

Wood Duck Nesting Boxes

Revised January 1977
by Dick Gersib
Wildlife Habitat Area Manager - Salt Valley

The Wood Duck (Aix sponsa), Nebraska's only tree nesting duck, has four major requirements for breeding habitat. These requirements are food, cover, water, and suitable nest cavities which govern the distribution of breeding wood ducks in Nebraska. Without any one of these four requirements, wood ducks would not be able to maintain a breeding population.

Very little is known about the spring food requirements of nesting wood ducks, and only the most general comments can be made. It is known that protein requirements for both the hen and ducklings are high. Pairs, especially hens, and ducklings feed extensively on both flying and aquatic insects, with plants such as duck weed and coontail also being utilized.

Wood ducks require close overhead cover which allows free movement through the water. Cover can be more open for breeders than for broods. Quiet water with overhead cover consisting of fallen and standing trees with emergent vegetation composed of arrowhead, cattail, sedges, and rushes seem to be adequate as brood rearing cover.

Wood ducks seem to prefer still or slow moving water protected from wind. This type of situation is created by beaver dams, backwaters, eddies of slack water, and of course ponds adjacent to timber.

One of, if not the most important habitat factor limiting wood duck populations over most of the wood duck range in Nebraska is the availability of nesting cavities. The wood duck nests in hollow trees formed by decay. These hollowed out nest sites or natural cavities are usually short lived due to destruction from wind or occupation by other wildlife.

Fortunately, the most critical habitat factor is also the factor most easily manipulated by man. The construction and installation of wood duck nest boxes has been a successful attempt at artificially duplicating natural nesting cavities. Because of this fact, there is a potential for assisting the Nebraska wood duck population by providing nest boxes in areas where breeding populations presently exist.

Many people, both waterfowl hunters and bird watchers, construct and maintain wood duck nesting boxes each year. In addition, many Federal and State conservation agencies are actively participating in this program.

Depending on the circumstances, ducks can be induced to nest the first year after a box is installed, or it might take several years. Since the female duck homes back to her natal area or the area where she nested before, the hen will not move to a new area to nest, unless there is a lack of nesting sites in her natal area.

However, if breeding birds are frequently observed in a particular area, there is a good chance of getting these birds to accept a nest box. Once a nest box is accepted, it will usually be continually used. It then becomes a question of how many boxes one wishes to construct and maintain, and how large of a population the area will support.

On the other hand, you can't expect to get use of a nest box if birds do not normally nest in the general area. You cannot just randomly put up a box and expect to have it used. There must be a breeding population to use it.

Attached is a plan for nest box construction, and how to install and maintain the box.

WOOD DUCK NESTING FACILITY

Completed Structure

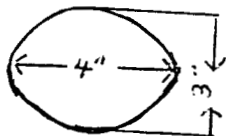
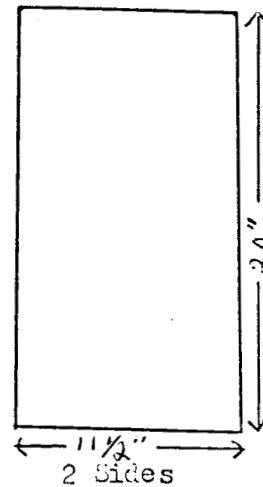
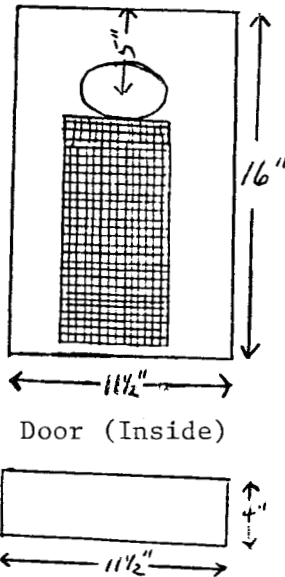
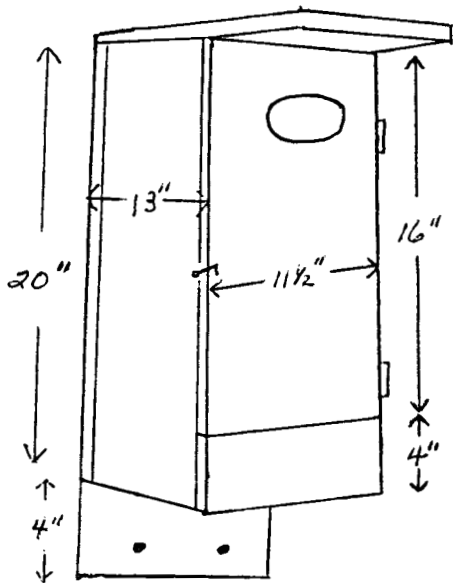

Elliptical Entrance

Below Door

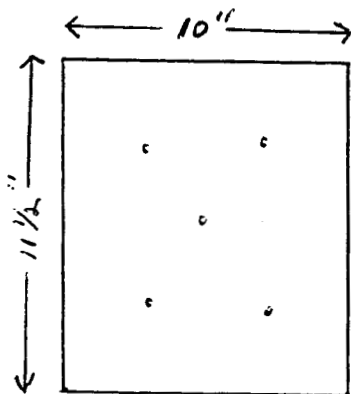
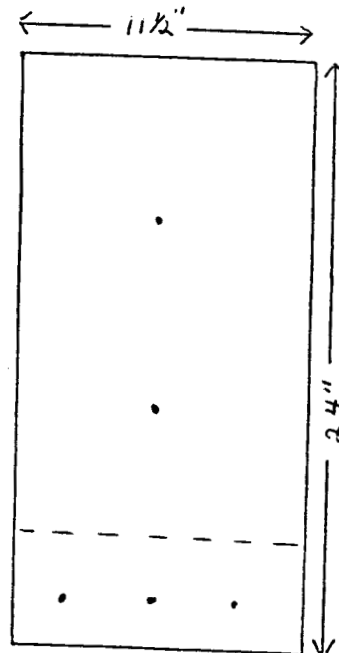
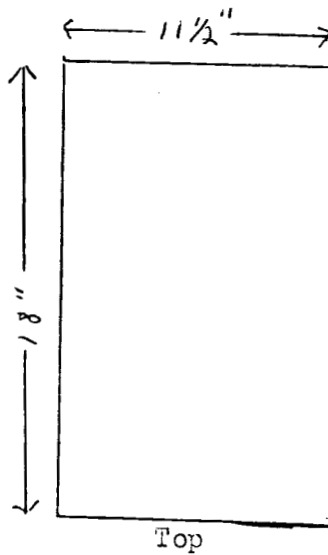

Bottom

Back

Materials

1. Ten linear feet of 1" x 12" lumber
2. Two hinges for door
3. One screen door hook
4. One 6" x 12" piece of hardware cloth (hailscreen). Use 1/4" material
5. Screws or nails - For best endurance, use wood screws or screw nails.
6. Paint: Inside - Black or other dark color
Outside - Brown seems to work well--do not use white

Use a good stain or latex type paint that will not leave a shine or glare. A good paint on the outside will give the box a longer life.

Note:

- (A) The entrance hole should be cut to an elliptical shape 3" x 4". This will deter raccoons from entering the box.
- (B) The 6" x 12" hardware cloth is attached to the inside of the door so ducklings can climb out of the nest.
- (C) Box should be constructed as tight as possible to exclude the entrance of light. The only light entering the box should be through the entrance hole.
- (D) Back section of box is sawed to 24" to facilitate mounting of box to tree or post.
- (E) The four inch by eleven and one half board below the door is designed to hold wood chips in the box during maintenance. The grain of wood must run lengthwise to prevent splitting.
- (F) Four to six small holes should be drilled through the bottom of the box to allow any water in the box to drain out freely.

Installation of the Nest Box:

Select a general location that has met the four requirements outlined earlier for wood duck breeding habitat, and preferably has some breeding birds present.

Once a general location has been selected, you can begin looking for suitable nest box sites. Keep in mind that although wood ducks will nest a considerable distance from water, it is a good practice to mount boxes over water or as near water as possible. This will make it easier for the hen to find a box, cut down on predation, and will also reduce duckling mortality. The shorter the walk to water, the better.

Wood duck nests have been recorded from ground level to as high as 57 feet, with the average nest height being 15 and 20 feet. A general rule of thumb is to mount boxes at least 10 feet high whenever possible.

Boxes can be installed by either attaching them to an existing tree or mounting them on steel or wooden posts.

When mounting boxes in trees, select trees in or over water whenever possible. Select a location on the tree that is relatively vertical, flat and easily accessible to a flying wood duck.

One disadvantage to the use of existing trees is the predator problem encountered. Squirrels and raccoons are the most persistent predators of our Nebraska wood duck flock. The squirrel will eat the eggs or compete for the nest site, while the raccoon will eat not only the eggs, but the hen as well. A partial solution is to mount boxes only on trees in or over water. On land, a piece of sheet metal or tin can be nailed around a tree to prevent predators from climbing to the nest box.

Steel or wooden posts serve as excellent mounting sites for nest boxes and can easily be placed out into the marsh or stream to prevent predation. Two steel posts per box are preferred for increased stability, while a single four inch by four inch wooden post or an old telephone pole will work equally well. When water depth will not permit the installation of boxes over water, sheet metal can be fastened to the post or pole to prevent predators from climbing to the box.

Wood duck nest box installation can be done most effectively in the winter when marshes and creeks are frozen. Steel sign posts or pipe can be driven through the ice and boxes installed quickly and easily. When installing boxes on wooden posts or poles, auger a hole in the ice and simply drive the post into the marsh bottom.

Attaching boxes to trees in the winter can be equally as convenient, with the use of a step ladder. The ladder can be set on the ice and boxes installed on trees over water that would be inaccessible to box installation any other time of year.

The box should be mounted to the post or tree with lag bolts, ring-shank nails, or screws. A good solid attachment will give greater life to the box.

Since wood ducks return to Nebraska in March to search out nest sites, it is a good idea to have the box installed no later than March 15 of each year. Old boxes should also be cleaned out by this time.

Most experts agree that the direction of the entrance hole does not make any difference. However, there is some evidence that wood ducks are a little reluctant to use a box where the morning sun enters the entrance hole. It is well known that they prefer to nest in a very dark nest site. Therefore, it is suggested that the entrance hole face any direction except east. Some shade on the box is also desirable.

Maintenance:

It is very important to clean the box each year by the middle of March, and add new litter. The bottom 4 inches of the box should be filled with wood shavings. Sawdust will work, but shavings are best. Do not use material with a high resin content.

The wood duck will not use a box that has no litter, for she must have this material to cover the eggs as they are laid. She will also hesitate to use a box that is full of the previous year's litter, or contains nests such as are built by starlings or squirrels.

Egg Laying, Hatching, and Leaving the Nest:

Depending on weather conditions, the wood duck hen will start laying eggs about the second week in April. She will usually lay 9-13 before incubation begins, although she may lay more. She will also cover each egg with the wood shavings to hide them from predators.

Towards the end of egg laying, she will start lining the nest with down until a nice round nest is formed. Incubation normally takes about 30 days, however, there are extremes of 25-37 days.

After hatching, the young ducklings will be brooded by the hen for about 24 hours before leaving the nest. The hen will then drop to the ground or water below, and start calling the ducklings out of the nest, providing all is clear.

The young ducklings will climb the hardware cloth to the entrance hole, one at a time, and will drop to the water or ground below. This drop apparently doesn't harm the ducklings. The hen will then gather her brood, and move off to good brooding cover.

Seldom do ducklings leave the nest past noon. Usually this is accomplished early in the morning, although they will leave anytime before noon.

To the person who has gone to the effort to construct and install a box or more, it is a wonderful sight to witness young wood duck ducklings pop out of a nest box.