

University of Nebraska - Lincoln

DigitalCommons@University of Nebraska - Lincoln

---

Robert Katz Publications

Research Papers in Physics and Astronomy

---

1-1958

## ***Physics*, Chapter 26: The Electric Current**

Henry Semat

*City College of New York*

Robert Katz

*University of Nebraska-Lincoln*, rkatz2@unl.edu

Follow this and additional works at: <https://digitalcommons.unl.edu/physicskatz>



Part of the [Physics Commons](#)

---

Semat, Henry and Katz, Robert, "*Physics*, Chapter 26: The Electric Current" (1958). *Robert Katz Publications*. 156.

<https://digitalcommons.unl.edu/physicskatz/156>

This Article is brought to you for free and open access by the Research Papers in Physics and Astronomy at DigitalCommons@University of Nebraska - Lincoln. It has been accepted for inclusion in Robert Katz Publications by an authorized administrator of DigitalCommons@University of Nebraska - Lincoln.

# 26

## The Electric Current

### 26-1 Sources of Electric Energy

Electricity is the basis of our present highly technical civilization. It is the means whereby energy from various sources is delivered to the consumer in a form suitable for its conversion into the many kinds of energy demanded by him. It is through the intermediary of the electric circuit that energy is transmitted electrically from the primary source, no matter where it is situated, to the ultimate consumer wherever he desires it. A complete electric circuit contains some form of electric generator, which is essentially a device for converting other forms of energy to electrical energy, a set of conductors for transmitting the electrical energy, and some device for converting this electrical energy into the desired form of energy.

There are various types of electric generators. We have already mentioned the electrostatic induction machine, of which the electrophorus is a crude example. More common is the chemical generator, of which there are two general types: (a) the primary chemical cell, in which a potential difference is developed by means of chemical action among some of the substances composing the cell (the so-called "dry cell" is a common form of primary chemical cell) and (b) the secondary chemical cell or *storage cell*, which must first be charged by sending electricity through it from some other generator, after which it acts just like a primary cell. The *storage battery* used in cars and on farms consists of several storage cells connected together. As a result of the chemical action which takes place in each of these cells, chemical energy is converted to electrical energy.

For the generation of large amounts of electric energy, the *dynamo* is used. The dynamo is driven by some kind of engine such as a steam engine, gasoline engine, or water turbine. Essentially, the dynamo converts mechanical energy into electric energy.

The chemical cell and the dynamo, as well as other forms of electric generators, will be discussed in greater detail in later chapters. In the present chapter we shall make use of electric generators, particularly the

d-c or *direct-current* generator, to study the properties of the electric circuit, but we shall reserve for a later chapter the discussion of how the generator operates. A d-c generator has two terminals, one of which is at a higher potential than the other. The terminal at the higher potential is called the *positive terminal*, and the other is called the *negative terminal*.

## 26-2 Current

Electric charge in motion constitutes an *electric current*. In the steady flow of charge in a wire of cross-sectional area  $A$ , as shown in Figure 26-1,

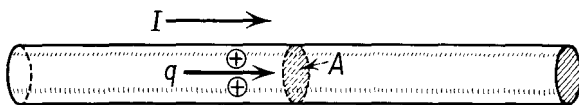

**Fig. 26-1** A current in a conductor consists of the flow of charges through any cross-sectional area  $A$ .

the total charge passing through this area in unit time is defined to be the electric current  $I$  at this place. If a total charge  $q$  flows through this area in time  $t$ , the current  $I$  is given by

$$I = \frac{q}{t}. \quad (26-1)$$

If  $q$  is expressed in statcoulombs and  $t$  in seconds, the current  $I$  is in cgs electrostatic units called *statamperes*. If  $q$  is expressed in coulombs and  $t$  in seconds, the current  $I$  is expressed in mks units called *amperes* (abbreviated amp). Thus an ampere is a coulomb per second, and 1 amp is approximately equal to  $3 \times 10^9$  statamperes. The ampere is named for André Marie Ampère (1775–1836), a pioneer electrical scientist.

The direction of the current is defined as the direction in which a positive charge would move. The nature of the charges whose motion constitutes the current depends upon the nature of the conducting substance. If the conductor is a metal, the current consists of the motion of *free electrons*. In a gas the charges which are set in motion are *positive* and *negative ions*, and, under conditions of low pressure, there may be electrons as well as the ions. In nonmetallic liquid conductors, such as electrolytes, the current consists of the motion of positive and negative ions. The positive charges move in the direction of the current, while the negative ions move in the opposite direction, as shown in Figure 26-2. In a conductor, flow of negative charge to the left is equivalent to a flow of positive charge to the

right, so that a current flowing to the right in the figure may be made up of positive charges flowing to the right and of negative charges flowing to the left.

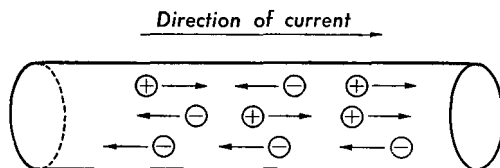

**Fig. 26-2** The direction of the current is the direction of motion of the positive charges. Negative charges move in a direction opposite to that of the current.

Unless specifically stated to the contrary, the equations dealing with electric currents are based upon the convention that the direction of the current is the direction of flow of positive charge.

When the flow of charge is not uniform, we may define the instantaneous current in terms of the rate of flow of charge. Thus we have

$$I = \frac{dq}{dt}. \quad (26-2)$$

### 26-3 Current Density

In dealing with the flow of electricity in a continuous medium, it is convenient to speak of the *current density*  $\mathbf{J}$ . *The current density is the quantity of charge passing through a unit area, perpendicular to the direction of motion of the charge, in a unit of time.* The direction of the current-density vector  $\mathbf{J}$  is the direction of motion of positive charge and hence of the current, and is opposite to the direction of motion of negative charge. In the case of the current in a wire such as that of Figure 26-1, the magnitude of the average current density is given by

$$J = \frac{I}{A}, \quad (26-3)$$

and the direction of the current density is along the wire in the direction of current.

We may represent the steady flow of current through a conductor of variable cross section by flow lines similar to the streamlines of fluid flow. Such a line of electric flow would then represent the path taken by charged particles, and the number of flow lines passing through a surface of unit area perpendicular to the direction of flow would represent the current density. As in the case of the streamline flow of a fluid, electric flow lines never cross. In the steady state the current passing any point in a conductor is constant. Thus the current density in a conductor of nonuniform

cross section, as shown in Figure 26-3, is inversely proportional to the cross-sectional area. At the points 1 and 2 in the conductor we have

$$I_1 = I_2,$$

so that

$$J_1 A_1 = J_2 A_2.$$

Thus we have

$$\frac{J_1}{J_2} = \frac{A_2}{A_1}. \tag{26-4}$$

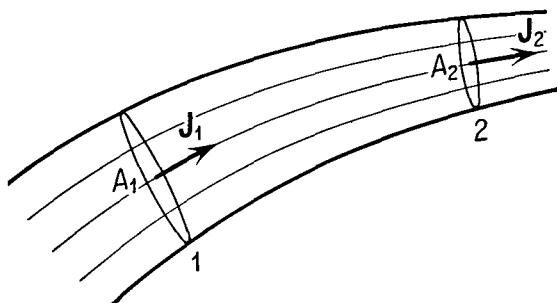

Fig. 26-3

This analogy between electric flow lines and streamlines in a fluid is of considerable practical use in the solution of aerodynamic flow problems through the use of *electrolytic plotting tanks*.

Let us suppose that a positively charged cloud containing  $n$  particles per unit volume, each of charge  $q$ , is moving with velocity  $v$ , as shown in

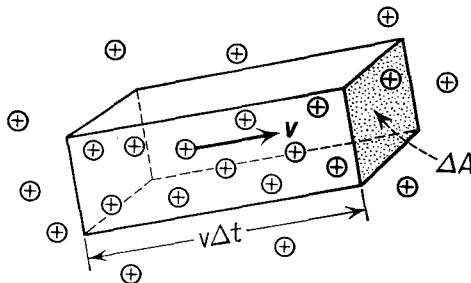

Fig. 26-4

Figure 26-4. All of the charged particles contained in a parallelepiped of base  $\Delta A$  and of altitude  $v \Delta t$  will pass through an element of area  $\Delta A$  perpendicular to the direction of flow in the time  $\Delta t$ . Thus the current density  $J$  is given by

$$J = \frac{(nq)(v \Delta t)(\Delta A)}{\Delta t \Delta A},$$

or

$$J = nqv. \tag{26-5}$$

Since the direction of the current density is the direction of motion of a positively charged particle, we may rewrite Equation (26-5) in vector form as

$$\mathbf{J} = nq\mathbf{v}. \quad (26-5a)$$

From Equation (26-5a) we see that if the charged particles are negatively charges, a negative number must be substituted for  $q$ , in which case  $\mathbf{J}$  is in the direction of  $-\mathbf{v}$ .

#### 26-4 Ohm's Law

*The current in a conductor of electricity is proportional to the difference of potential between the ends of the conductor.* This experimental observation was made by Georg Simon Ohm (1787–1854) in 1826 and is today known as Ohm's law. The constant of proportionality relating the current  $I$  to the potential difference  $V$  is called the *conductance*  $G$ , so that we may write Ohm's law in the form of an equation as

$$I = GV. \quad (26-6)$$

The same proportionality is often expressed in terms of a second constant called the *resistance*  $R$  as

$$V = IR. \quad (26-7)$$

When the current is expressed in amperes and the potential difference in volts, the resistance is expressed in *ohms*. From Equations (26-6) and (26-7) the conductance is the reciprocal of the resistance; that is,

$$G = \frac{1}{R}. \quad (26-8)$$

The units of conductance are reciprocal ohms or *mhos*. The cgs system of units is rarely used in connection with the current through a conductor; cgs units of conductance and resistance are called *statmhos* and *stathms*, respectively.

Ohm's law in the form of Equation (26-7) is simultaneously a very concise statement about the properties of a great many conductors and a definition of the resistance of a conductor. In a strict sense the term "resistance" should not be used for a conductor unless there is a fixed constant value of  $R$  for that conductor, when it is maintained at a fixed temperature, for all values of the potential difference across it. For metals, Ohm's law is true over an extremely large range of values of  $V$  separated by factors of  $10^{12}$  or more. The term "resistance" has sometimes been extended to mean the quotient of the voltage across the terminals of a

conductor divided by the current through the conductor without regard to whether this quotient is constant for a particular temperature.

Resistance elements, called *resistors*, are constructed for use in electrical circuits. These are schematically represented by the symbols shown in Figure 26-5. The symbol commonly used for abbreviating the word "ohm"



**Fig. 26-5** Schematic symbols for (a) fixed resistor and (b) variable resistor.

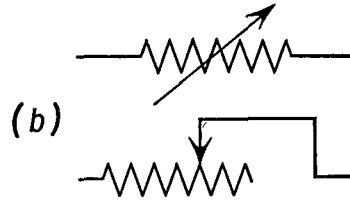

is the greek capital omega  $\Omega$ . Following the usual system of notation for multiples in the metric system, large resistances are generally represented in *megohms*, while small resistances are represented as *microhms*.

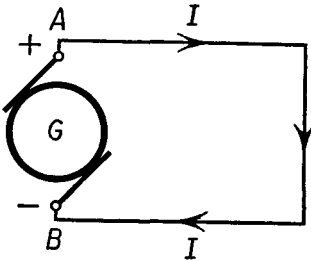

**Fig. 26-6** Direction of the current in a circuit.

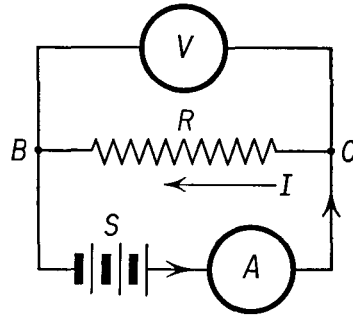

**Fig. 26-7** Voltmeter-ammeter method for measuring the resistance of a conductor.

We have previously shown that when a positive charge moves under the influence of an electric field, its direction of motion is from a point of higher potential to a point of lower potential. If two such points, say the terminals *A* and *B* of a generator, are connected by a conductor, as shown in Figure 26-6, the direction of the current in the conductor will be from *A*, the point at the higher potential, to *B*, the point at the lower potential.

A simple way of measuring the resistance of a wire is illustrated in Figure 26-7. The wire *BC* whose resistance *R* is to be measured is connected to a storage battery *S* and an ammeter *A*. The voltmeter *V* is

connected across the terminals of the wire  $BC$ . In the illustration the various elements of the electric circuit are represented schematically in a conventional manner. The longer of the two strokes representing each of the cells of the storage battery represents the positive terminal. A conductor having negligible resistance is represented by a straight line. The reading of the ammeter gives the current  $I$  in the wire  $BC$ , assuming that the current through the voltmeter is negligible, while the voltmeter reading gives the difference of potential  $V$  between  $B$  and  $C$ . This is sometimes referred to as the *voltage* across  $BC$ . The resistance  $R$  of the wire is then calculated from Ohm's law

$$R = \frac{V}{I}.$$

### 26-5 Electrical Energy

When a particle of charge  $q$  is displaced through a difference of potential  $V$ , an amount of work  $\mathcal{W}$  is performed such that

$$\mathcal{W} = qV. \quad (26-9)$$

When the work is done by the electric field on the charged particle, that work may appear as a difference in kinetic energy of the charged particle, or, in the event that the charged particle moves with constant speed as a result of the action of some type of resisting force opposing the motion, the work  $\mathcal{W}$  may appear as heat. Equation (26-9) may be expressed in terms of the current  $I$  instead of the charge  $q$ . For the case of a constant current, we get from Equation (26-1)

$$q = It;$$

hence

$$\mathcal{W} = VI t. \quad (26-10)$$

Dividing both sides of Equation (26-10) by the time, we find

$$\frac{\mathcal{W}}{t} = VI,$$

and since the power  $\mathcal{P}$  is equal to the work divided by the time, we have

$$\mathcal{P} = VI. \quad (26-11)$$

It is essential that consistent units be used in these equations; when mks units of electrical quantities are used, the mks units of work, the joule, and of power, the watt, must be used. For example, when a current of 5 amp flows between two points whose potential difference is 110 volts, the electrical power supplied is 550 watts.

Comparing Equations (26-7) and (26-11), we obtain the power  $\mathcal{P}$  supplied to a conductor of resistance  $R$ , through which a current  $I$  flows



when a potential difference  $V$  is applied across its terminals as

$$\mathcal{P} = I^2 R, \quad (26-12a)$$

or

$$\mathcal{P} = \frac{V^2}{R}. \quad (26-12b)$$

The power supplied to an electrical conductor when current flows through it appears in the form of heat and possibly light. Among the many experiments which Joule performed to determine the mechanical equivalent of heat, there were some which involved the transformation of electrical

**Fig. 26-8** Transformation of electric energy into heat; heating a quantity of water by means of an electric current in a wire of resistance  $R$  immersed in it.  $Am$  is an ammeter,  $B$  is a battery.

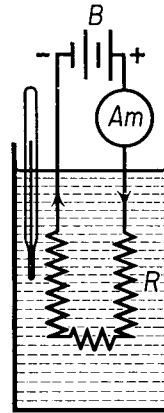

energy into heat. A coil of wire was immersed in water of known mass in a calorimeter, as shown in Figure 26-8. Joule found that the rate at which electrical energy was converted into heat in a conductor was proportional to the square of the current flowing through the conductor, a result which was important in establishing the universality of the concept of energy. We have used the energy concept as a means of deriving Joule's experimental result from Ohm's law in Equation (26-12a), which is sometimes called *Joule's law*.

*Illustrative Example.* The heating coil of an electric iron operating on a 110-volt line has a current of 5 amp in it. Determine (a) the resistance of the coil, (b) the power supplied to it, and (c) the amount of heat flowing out of the coil in 4 min.

(a) The resistance of the coil is, from Equation (26-7),

$$R = \frac{V}{I} = \frac{110 \text{ volts}}{5 \text{ amp}} = 22\Omega.$$

(b) The power supplied to the coil is, from Equation (26-11),

$$\mathcal{P} = VI = 110 \text{ volts} \times 5 \text{ amp} = 550 \text{ watts},$$

or, from Equation (26-12a),

$$\mathcal{P} = I^2 R = 25 \text{ amp}^2 \times 22 \Omega = 550 \text{ watts.}$$

(c) Since all of the electrical energy  $\mathcal{W}$  is converted into heat, we can write

$$\begin{aligned} \mathcal{W} &= \mathcal{P}t = 550 \text{ watts} \times 240 \text{ sec} \\ &= 132,000 \text{ joules,} \end{aligned}$$

or, using the mechanical equivalent of heat

$$4.2 \text{ joules} = 1 \text{ cal,}$$

we get

$$\mathcal{W} = \frac{132,000}{4.2} \text{ cal} = 31,400 \text{ cal.}$$

## 26-6 Resistivity and Conductivity

To describe the properties of a continuous medium, we may rewrite Ohm's law in terms of the conductivity  $\sigma$  and the resistivity  $\rho$  rather than in terms of the conductance  $G$  and the resistance  $R$  which were used for discrete conductors. If the electric field intensity within a conductor is  $E$  and the current density is  $J$ , we may write Ohm's law for a continuous medium as

$$J = \sigma E \quad (26-13a)$$

or as

$$E = \rho J, \quad (26-13b)$$

where  $\sigma$  is the reciprocal of  $\rho$ ; thus

$$\sigma = \frac{1}{\rho}. \quad (26-14)$$

Although both Equations (26-13a) and (26-13b) have been written in scalar form, we recognize that the vector  $\mathbf{J}$  is parallel to the vector  $\mathbf{E}$  and that  $\sigma$  and  $\rho$  are scalar constants relating the current density to the electric field intensity, in a homogeneous isotropic conductor. From Equations (26-13) and (26-14) the units of  $\sigma$  in mks units are *mhos per meter*, while the units of  $\rho$  are *ohms meter*.

To find the relation between conductance and conductivity, let us consider a uniform wire of cross-sectional area  $A$  and length  $s$  in which there is a current  $I$ , as shown in Figure 26-9. From Equation (26-3) the current density  $J$  in the wire is given by

$$J = \frac{I}{A}.$$

If the potential difference between the ends of the wire is  $V$ , the end  $a$  being at the higher potential, the electric field intensity within the wire is given by

$$E = \frac{V}{s}$$

TABLE 26-1 RESISTIVITY OF CONDUCTING MATERIALS

| Substance | Resistivity<br>in ohm-cm at 20°C | Temperature Coefficient<br>per °C at 20° C |
|-----------|----------------------------------|--|
| Aluminum  | $2.83 \times 10^{-6}$            | 0.0039                                     |
| Carbon    | $3.5 \times 10^{-3}$             | -0.0005                                    |
| Copper    | $1.72 \times 10^{-6}$            | 0.0038                                     |
| Iron      | $10 \times 10^{-6}$              | 0.0050                                     |
| Manganin  | $44 \times 10^{-6}$              | 0.00001                                    |
| Nichrome  | $100 \times 10^{-6}$             | 0.0004                                     |
| Platinum  | $10 \times 10^{-6}$              | 0.0038                                     |
| Silver    | $1.63 \times 10^{-6}$            | 0.0038                                     |
| Tungsten  | $5.51 \times 10^{-6}$            | 0.0045                                     |

and is in the direction of the current, from the point  $a$  to the point  $b$  parallel to the wire. Substituting these values into Equation (26-13a), we have

$$\frac{I}{A} = \sigma \frac{V}{s},$$

$$I = \frac{\sigma A}{s} V.$$

Fig. 26-9

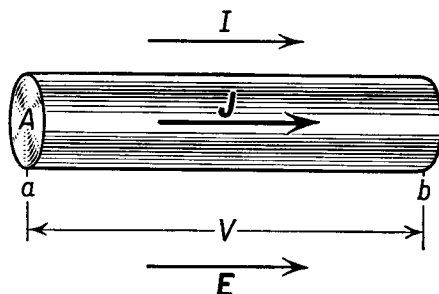

By comparing this result with Equation (26-6), we see that the conductance  $G$  of a wire may be expressed in terms of its cross-sectional area  $A$ , its length  $s$ , and the conductivity  $\sigma$  of the material of which it is made as

$$G = \frac{\sigma A}{s}. \quad (26-15)$$

Similarly, the resistance  $R$  of a wire may be expressed in terms of its resistivity  $\rho$  as

$$R = \frac{\rho s}{A}. \quad (26-16)$$

From Equation (26-15) it may be seen that the conductivity  $\sigma$  is the conductance of a unit cube whose area  $A$  is 1 and whose length is also 1; similarly it may be observed from Equation (26-16) that the resistivity  $\rho$  is the resistance of a unit cube. In handbooks the resistivity is often expressed in units of ohm centimeter rather than ohm meter. This number may be used directly in Equation (26-16) by using the length of the wire in centimeters and its cross-sectional area in square centimeters, or by converting ohm centimeters to ohm meters according to

$$1 \text{ ohm cm} = 1 \text{ ohm cm} \times \frac{1 \text{ m}}{100 \text{ cm}} = \frac{1}{100} \text{ ohm m},$$

and using the appropriate mks units of length and area.

A variety of factors influence the resistivity of substances. For example, the resistivity of a conductor is affected by the state of internal strain. This is utilized in the *electrical strain gauge* in which a wire is cemented to a structural member and the strain of the member is determined by measuring the change in electrical resistance of the wire when a load is applied to the member.

The resistivity of bismuth is affected by a magnetic field, thus providing a basis for the measurement of the magnetic field with a bismuth probe. The resistivity of selenium is altered by incident light, and thin films of selenium may be used to measure light intensity. At very low temperatures, in the vicinity of a few degrees Kelvin, some metals have extremely low resistivity. The transition from the normal state to this *superconductive* state takes place in lead at a temperature of 7.3°K. If currents are started in a lead ring in the superconductive state, the current does not diminish by 0.1 per cent per hour. These currents are started and detected by magnetic means, to be described in a subsequent chapter.

Insulating materials permit the passage of very weak currents which are usually negligible. These materials do not generally obey Ohm's law; typical values of the resistivity obtained at a particular value of the electric field intensity are usually quoted in handbooks for design purposes.

Insulating materials of high resistivity are used in the construction of electrical apparatus, and there is often the problem of current flow along the surface of the insulation rather than through the volume of the insulation. To minimize these surface currents a long surface path is often provided by corrugating the surface of an insulator. If we consider the factors affecting the electrical resistance of a conducting surface, we see that we would expect the resistance to increase directly with the separation of the electrodes  $a$  and to decrease with the length of the electrodes  $b$ , as shown in Figure 26-10. In the form of an equation we write

$$R = \rho_s \frac{a}{b}. \quad (26-17)$$

Since both  $a$  and  $b$  are lengths, the quantity  $\rho_s$ , the surface resistivity, has the dimensions of resistance. The surface resistivity is often stated in units of ohms, or ohms per square, for in a square the lengths  $a$  and  $b$  are the same. The surface resistivity is the resistance between opposite sides of any square

Fig. 26-10

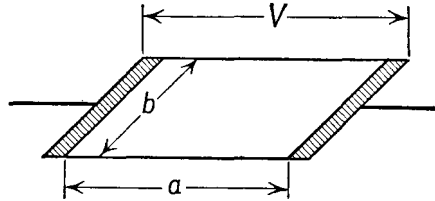

on the surface of the material. The volume resistivity and the surface resistivity for several insulating materials are given in Table 26-2. The surface resistivity of an insulator is affected by humidity. This effect has been utilized to determine the humidity of the atmosphere by employing glass surfaces with specially prepared surface coatings.

TABLE 26-2 VOLUME RESISTIVITY AND SURFACE RESISTIVITY OF SOME INSULATING MATERIALS

| Material     | Volume resistivity (ohm cm) | Surface resistivity (90% humidity) (ohms per square) |
|--------------|-----------------------------|--|
| Bakelite     | $2 \times 10^{11}$          | $2 \times 10^8$                                      |
| Ceresin wax  | $5 \times 10^{18}$          | $1 \times 10^{17}$                                   |
| Glass        | $2 \times 10^{13}$          | $2 \times 10^6$                                      |
| Hard rubber  | $1 \times 10^{18}$          | $2 \times 10^9$                                      |
| Porcelain    | $3 \times 10^{14}$          | $5 \times 10^6$                                      |
| Shellac      | $1 \times 10^{16}$          | $6 \times 10^9$                                      |
| Wood (maple) | $3 \times 10^{10}$          | $2 \times 10^9$                                      |

**26-7 Temperature and Resistivity**

The resistivity of a conducting substance generally depends upon its temperature. Just as in the case of the thermal expansion of solids discussed in Chapter 14, it is possible to represent the resistivity as a function of temperature by means of a mathematical series. If  $\rho_0$  is the resistivity of the substance at some reference temperature  $t_0$ , the resistivity  $\rho_t$  at temperature  $t$  may be expressed as

$$\rho_t = \rho_0[1 + \alpha(\Delta t) + \alpha'(\Delta t)^2 + \dots],$$

where  $\alpha$ ,  $\alpha'$ , and so on, are constant coefficients to be evaluated at the

reference temperature  $t_0$ , and

$$\Delta t = t - t_0.$$

It is often sufficient to approximate the above expression by the first two terms, so that we obtain

$$\rho_t = \rho_0 (1 + \alpha \Delta t), \quad (26-18)$$

where  $\alpha$  is called the *temperature coefficient of resistivity* at the temperature  $t_0$ . Values of  $\alpha$  for some of the common conducting materials are listed in Table 26-1. For metallic conductors  $\alpha$  is always positive, which means that the resistance of a metallic conductor increases with temperature. Many nonmetallic conductors, such as carbon, have negative temperature coefficients, so that the resistivity decreases as the temperature increases. Other substances, such as the semiconductors germanium and silicon, exhibit positive coefficients at low temperatures and negative coefficients at high temperatures. In the particular case of semiconductors, the temperature coefficient of resistance is particularly sensitive to the impurity content. Circuit elements which exhibit large temperature coefficients of resistance are useful in many applications, either to compensate for the temperature variations in other parts of the circuit or to act as temperature indicators. Such elements are called *thermistors*. Some alloys, such as manganin, have been developed which have negligible temperature coefficients of resistance. These are useful for making coils whose resistance does not vary with temperature to any appreciable extent.

Some substances which are very good insulators at ordinary temperatures may become good conductors at high temperatures. The resistivity of glass at ordinary temperatures is of the order of  $10^{14}$  ohm cm, but if a glass rod is raised to a temperature of about  $400^\circ\text{C}$ , it becomes a good conductor. If a glass rod is connected to the terminals of a 110-volt source and is heated to about  $400^\circ\text{C}$ , an appreciable current begins to flow in the rod. If the flame is removed, the current will continue to flow and even to increase in value until the glass melts, for the glass has a negative coefficient of resistivity.

The change with temperature in the resistance of a wire provides the basis for the *resistance thermometer*. The temperature-measuring element consists of a small coil of fine wire wound on an insulating quartz rod and surrounded by a protective quartz cylinder. The platinum resistance thermometer has been accepted as a standard means of measuring temperature in the range  $-190^\circ\text{C}$  to  $+660^\circ\text{C}$ . To achieve sufficient precision in the measurement of temperature with a platinum resistance thermometer the second- and third- order terms must be included in the formula for the variation of resistivity with temperature.

**26-8 Resistance Measurements: Wheatstone Bridge**

We have already discussed one method for measuring a resistance which involves the use of an ammeter and voltmeter. A much more accurate method for determining the resistance of a resistor, known as the *Wheatstone bridge method*, named for Charles Wheatstone (1802–1875), involves the use of three other resistors and a very sensitive current-measuring instrument known as a *galvanometer*. The circuit used is shown in Figure 26-11(a) in

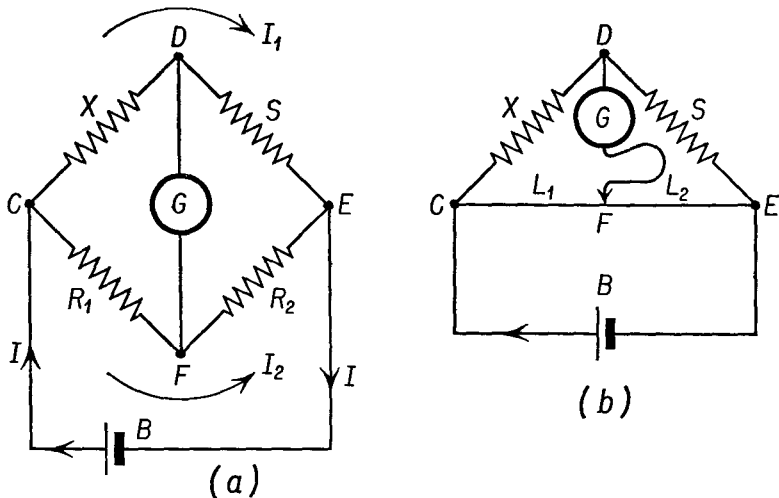

**Fig. 26-11** (a) The Wheatstone bridge. (b) The slide wire form of Wheatstone bridge. The currents in the bridge are shown when the bridge is balanced; that is, when there is no current through the galvanometer.

which  $X$  is the resistance to be measured,  $R_1$ ,  $R_2$ , and  $S$  are three other resistors,  $G$  is the galvanometer, and  $B$  is a battery. Let us suppose that the values of the three resistances  $R_1$ ,  $R_2$ , and  $S$  have been so chosen that the galvanometer reads zero; that is, no current flows through it, which means that the difference of potential between  $D$  and  $F$  is zero, or that  $D$  and  $F$  are at the same potential. The bridge is then said to be balanced. At balance the potential difference between  $C$  and  $D$  is equal to the potential difference between  $C$  and  $F$ , or

$$V_{CD} = V_{CF},$$

and, similarly,

$$V_{DE} = V_{FE}.$$

Since there is no current from  $D$  to  $F$ , the current in  $DE$  is the same as that in  $CD$ . For the same reason the current in  $FE$  is the same as that in  $CF$ .

Applying Ohm's law to each of the resistors and substituting in the

above equations, we get

$$I_1 X = I_2 R_1,$$

and

$$I_1 S = I_2 R_2,$$

in which  $I_1$  is the current in  $X$  and  $S$ , and  $I_2$  is the current in  $R_1$  and  $R_2$ .

From the above equations, we get

$$X = \frac{R_1}{R_2} S. \quad (26-19)$$

Thus if  $S$  is a known resistance, and the ratio of the two resistances  $R_1$  and  $R_2$  is known, the resistance  $X$  can be easily determined.

In laboratory work,  $S$  is either a single standard resistance whose value is known accurately, or else it consists of a series of coils of known resistances permitting a choice of a variety of values for  $S$ .  $R_1$  and  $R_2$  may consist of a single wire of known length and a slider making contact at some point  $F$ , Figure 26-11(b). Usually, when contact is first made at some point on this wire, a current will be started in the galvanometer. The slider is then moved along the wire until a point  $F$  is reached which is at the same potential as  $D$ , so that there is no current through the galvanometer. If the length of the wire from  $C$  to  $F$  is  $L_1$ , and from  $F$  to  $E$  is  $L_2$ , then, since the resistance of a uniform wire is proportional to its length, we can write

$$\frac{R_1}{R_2} = \frac{L_1}{L_2},$$

and Equation (26-19) becomes

$$X = \frac{L_1}{L_2} S. \quad (26-20)$$

Thus the measurement of a resistance is reduced to the measurement of the ratio of two lengths. This form of the Wheatstone bridge is usually called a *slide-wire* bridge.

### Problems

26-1. What is the current when a charge of 6 coul passes through a wire in 2 sec?

26-2. How many electrons pass through the cross-sectional area of a wire in 1 sec if the wire is carrying a current of 1 amp. The charge of an electron is  $-1.60 \times 10^{-19}$  coul.

26-3. A charged cloud containing  $10^{15}$  electrons/cm<sup>3</sup> is moving in the positive  $x$  direction with a velocity of 150 m/sec. What is the current density (magnitude and direction) to be associated with the motion of the charged cloud?

26-4. A resistor carries a current of 6 amp when the voltage across it is 120



volts. (a) Determine its resistance. (b) Determine its conductance. (c) How much power is supplied to the resistor?

26-5. A 120-volt, 40-watt lamp is connected to a 120-volt line. (a) How much current does it require under normal operating conditions? (b) What is its resistance under these conditions?

26-6. An electric furnace powered by a 1,000-watt heating element contains a small opening  $10 \text{ cm}^2$  in area in one end. If the only heat loss from the furnace is due to radiation from the opening, what will be the maximum temperature of the furnace?

26-7. (a) Calculate the resistance of a copper wire 1 m long and 2 mm in diameter at  $0^\circ\text{C}$ . (b) What is the resistance of a piece of Nichrome wire of the same size at the same temperature?

26-8. A Nichrome wire 10 m long and 2 mm in diameter is connected to a 6-volt storage battery. (a) What is the resistance of the wire? (b) What will be the current in the wire? (c) What will be the difference in potential between two points on the wire 1 m apart?

26-9. The resistance of a platinum wire used in a resistance thermometer is 4.85 ohms at  $0^\circ\text{C}$ . When used to measure the temperature of a liquid, the resistance is found to be 5.97 ohms. Determine the temperature of the liquid.

26-10. The resistance of a platinum wire is 6.25 ohms at  $20^\circ\text{C}$ . What is its resistance at  $100^\circ\text{C}$ ?

26-11. A pair of plates  $1 \text{ m}^2$  in area is separated by a distance of 10 cm. The plates are immersed in a brine solution. Assuming that the current density in the brine solution is uniform, determine the conductivity of the brine solution if there is a current of 10 amp between the plates when the difference in potential is 24 volts.

26-12. The conductivity of a normal solution of KCl at  $15^\circ\text{C}$  is 0.093 mho/cm. (a) What is the conductance between the plates  $1 \text{ m}^2$  in area immersed in this solution if the separation between the plates is 25 cm? (b) What potential difference must be maintained between the plates if a current of 5 amp is to flow through the tank? (c) What will be the current density, assuming that it is uniform?

26-13. In a printed circuit two conductors 10 cm long are printed onto a dielectric. The conductors are separated by a distance of 3 mm. If the surface resistivity of the dielectric is  $2 \times 10^8$  ohms/square, what will be the resistance between the conductors?

26-14. Two conductors in the form of concentric cylindrical rings are imbedded in a sheet of Bakelite 1 cm thick of volume resistivity  $2 \times 10^{11}$  ohm cm. The diameter of the inner conducting ring is 2 cm, while the diameter of the outer conducting ring is 5 cm. Find the resistance of the Bakelite between the two rings. (Use calculus method.)

26-15. In Problem 26-14 compute the surface resistance between the conducting rings, taking both surfaces of the Bakelite into account. The surface resistivity of the Bakelite is  $2 \times 10^8$  ohms/square.

26-16. The precision to which commercial electrical panel meters are made is 2 per cent. What is the largest percentage error which can be expected in measuring a resistor by the use of a voltmeter and ammeter?