

University of Nebraska - Lincoln

DigitalCommons@University of Nebraska - Lincoln

Robert Katz Publications

Research Papers in Physics and Astronomy

1-1958

***Physics*, Chapter 6: Circular Motion and Gravitation**

Henry Semat

City College of New York

Robert Katz

University of Nebraska-Lincoln, rkatz2@unl.edu

Follow this and additional works at: <https://digitalcommons.unl.edu/physicskatz>



Part of the [Physics Commons](#)

Semat, Henry and Katz, Robert, "*Physics*, Chapter 6: Circular Motion and Gravitation" (1958). *Robert Katz Publications*. 146.

<https://digitalcommons.unl.edu/physicskatz/146>

This Article is brought to you for free and open access by the Research Papers in Physics and Astronomy at DigitalCommons@University of Nebraska - Lincoln. It has been accepted for inclusion in Robert Katz Publications by an authorized administrator of DigitalCommons@University of Nebraska - Lincoln.

6

Circular Motion and Gravitation

6-1 Circular Motion

Our earlier discussion of the kinematics of a particle was developed principally from the point of view of being able to describe that motion easily within a rectangular coordinate system. Thus the most complex case with which we dealt was that of a projectile motion, in which the acceleration was constant and was directed along one of the coordinate axes. A more convenient framework within which to discuss rotational and circular motions is provided by a set of polar coordinates. In the present discussion we

will restrict ourselves to motion in which the polar coordinate r is constant, or fixed; that is, the particle is constrained to move in a circular path.

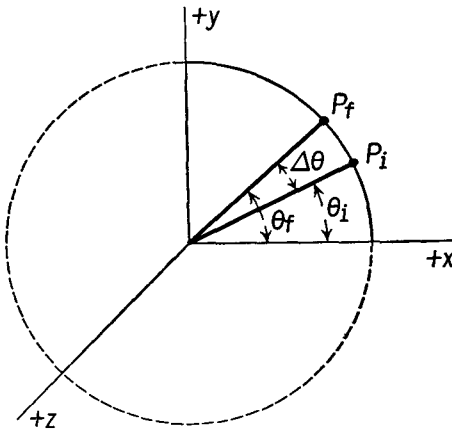

Fig. 6-1 Angular displacement.

at angle θ_i and is finally at position P_f at angle θ_f , we say that its *angular displacement* $\Delta\theta$ is given by its final angular coordinate minus its initial angular coordinate. In the form of an equation we have

$$\Delta\theta = \theta_f - \theta_i, \quad (6-1)$$

as shown in Figure 6-1. In polar coordinate notation, angles are measured counterclockwise from the x axis. A positive angular displacement implies that the particle has been displaced in a counterclockwise direction around the circle, while a negative displacement implies a clockwise displacement.

An angular displacement may be expressed in degrees or in radians or in revolutions. As we have previously seen, 1 revolution corresponds to 360° or to 2π radians, so that

$$1 \text{ radian} = \frac{360^\circ}{2\pi} = 57.3^\circ.$$

6-3 Angular Speed and Angular Velocity

The *average angular speed* $\bar{\omega}$ (omega bar) is defined as the quotient of the angular displacement $\Delta\theta$ divided by the time interval Δt in which that displacement took place. In the form of an equation, we have

$$\bar{\omega} = \frac{\Delta\theta}{\Delta t}. \quad (6-2)$$

When $\Delta\theta$ is expressed in radians and Δt is expressed in seconds, $\bar{\omega}$ is given in units of radians per second. Other appropriate units may be used.

The *instantaneous angular speed* at a point ω is obtained by a limiting process analogous to the process used in the definition of the instantaneous linear speed. Without going through the details of that process, we may write

$$\omega = \lim_{\Delta t \rightarrow 0} \frac{\Delta\theta}{\Delta t} = \frac{d\theta}{dt}. \quad (6-3)$$

If the angular speed is constant, the average angular speed $\bar{\omega}$ is equal to the instantaneous angular speed ω . A particle whose angular speed is changing is said to have angular acceleration.

A particle on the rim of a spinning wheel is moving in circular motion with the angular speed of the wheel, but the angular speed alone is not a sufficient description of the motion, for, in order to know where the particle will be at some subsequent time, it is necessary to know the axis about which the wheel is rotating. To describe more completely a rotational motion with constant angular speed, it is necessary to specify both the angular speed and the direction of the axis of rotation.

We may describe the *angular velocity* of a particle in circular motion as a *vector quantity* whose magnitude is its angular speed and whose direction is along the axis about which the particle is rotating. The sense of the angular-velocity vector is given by the *right-hand rule* used to describe the

torque vector. If the bent fingers of the right hand are pointed in the direction of rotation of the particle, the outstretched thumb indicates the direction of the angular-velocity vector along the axis of rotation. Thus in Figure 6-1 the angular-velocity vector of the particle rotating about the z axis from P_i to P_f would be in the positive z direction.

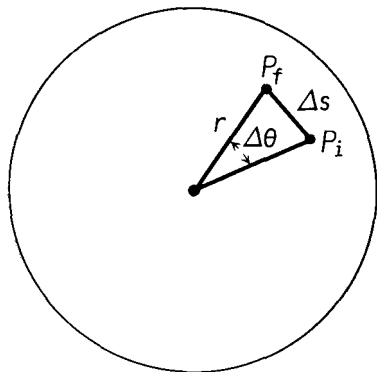

Fig. 6-2

P_f , through a small arc of length Δs , while the angular displacement of every particle of the disk has been $\Delta\theta$, as shown in Figure 6-2. We have

$$\Delta\theta = \frac{\Delta s}{r},$$

where r is the radial distance of the particle from the axis of rotation.

Thus

$$\Delta s = r \Delta\theta,$$

and, dividing both sides of the equation by the time interval Δt , we obtain

$$\frac{\Delta s}{\Delta t} = r \frac{\Delta\theta}{\Delta t},$$

from which we see that the instantaneous linear speed v with which the particle moves is the product of r by its angular speed ω . In the form of an equation we have

$$v = \omega r. \quad (6-4)$$

From Equation (6-4) we see that the particles near the rim of a disk which rotates about a fixed axis move with greater linear speed than do particles which are nearer the axis of rotation. The particles on the axis of rotation have zero linear speed; they are at rest.

Illustrative Example. An airplane propeller is rotating with uniform angular

speed of 1,800 rpm. The blades of the propeller are 6 ft long. Determine the linear speed of a point (a) 2 ft from the axis and (b) 6 ft from the axis.

Expressing the angular speed in radians per second, we get

$$\omega = \frac{2\pi \times 1,800}{60} \frac{\text{radians}}{\text{sec}} = 188.4 \frac{\text{radians}}{\text{sec}}.$$

(a) Using Equation (6-4) with $r = 2$ ft, we get

$$v = 188.4 \frac{\text{radians}}{\text{sec}} \times 2 \text{ ft} = 376.8 \frac{\text{ft}}{\text{sec}};$$

and when $r = 6$ ft, we get

$$(b) \quad v = 188.4 \frac{\text{radians}}{\text{sec}} \times 6 \text{ ft} = 1,130 \frac{\text{ft}}{\text{sec}}.$$

As discussed in Chapter 1, the term "radian" has no physical dimensions since it is the ratio of two lengths; hence such a unit as $\frac{\text{radians}}{\text{sec}} \times \text{ft}$ is equivalent to the unit $\frac{\text{ft}}{\text{sec}}$.

6-5 Angular Acceleration

Since angular velocity is a vector quantity, it can change in either direction or magnitude or in both. An airplane generally cruises with its engines turning at a steady rate. Its propellers therefore rotate at a fixed angular speed. When the airplane makes a turn, the angular speed of the propellers remains fixed, but the direction of the axis of rotation is changing and therefore the angular velocity is changing, with important consequences which will be discussed in a later section. In this section we shall consider changes in the magnitude of the angular velocity only. Just as for linear acceleration, we shall define the angular acceleration as the change in angular velocity in a time interval Δt .

We define the *average angular acceleration* $\bar{\alpha}$ (alpha bar) as the change in angular velocity $\Delta\omega$ divided by the time interval Δt in which that change takes place. In the form of an equation we have

$$\bar{\alpha} = \frac{\Delta\omega}{\Delta t}. \quad (6-5)$$

The instantaneous angular acceleration α is again obtained by a limiting process, and we may write

$$\alpha = \lim_{\Delta t \rightarrow 0} \frac{\Delta\omega}{\Delta t} = \frac{d\omega}{dt}. \quad (6-6)$$

Since the angular acceleration is given by the result of dividing $\Delta\omega$, a vector, by Δt , a scalar, the angular acceleration α is a vector quantity. In the present chapter we shall deal only with the case in which the motion takes place about a fixed axis. The angular-velocity vector will always be directed parallel to that axis. Changes in the angular velocity will therefore also be directed parallel to the axis of rotation. Thus in this case the angular-acceleration vector must be parallel to the axis of rotation.

6-6 Equations of Motion for Constant Angular Acceleration

The defining equations for linear motion and for angular motion are identical except for the symbols used. In the equations representing linear motion, the symbols x , v , and a need only be replaced by θ , ω , and α to obtain the corresponding equations for angular motion. From the definitions of velocity and acceleration, a few mathematical manipulations enabled us to obtain equations relating such quantities as displacement, velocity, acceleration, and time, which were of considerable usefulness in describing the motion of a particle. For rotational motion it will not be necessary to repeat the development of these equations, for we have deciphered the code which enables us to translate freely from angular motion to linear motion. To translate equations developed for linear motion to equations appropriate for use in angular motion, we simply replace the symbol x by θ , v by ω , and a by α . The symbol u which was used to represent the initial linear velocity will be replaced by the symbol ω_i to represent initial angular velocity.

We display the correspondence between the equations representing linear motion and those representing angular motion as follows:

Linear Motion	Angular Motion	
$x = \bar{v}t$	$\theta = \bar{\omega}t$	(6-7a)
$v = u + at$	$\omega = \omega_i + \alpha t$	(6-7b)
$x = ut + \frac{1}{2}at^2$	$\theta = \omega_i t + \frac{1}{2}\alpha t^2$	(6-7c)
$v^2 = u^2 + 2ax$	$\omega^2 = \omega_i^2 + 2\alpha\theta$	(6-7d)
$\bar{v} = \frac{u + v}{2}$	$\bar{\omega} = \frac{\omega_i + \omega}{2}$	(6-7e)

Both sets of equations are for uniformly accelerated motion. The equations for linear motion represent motion in a straight line, here chosen as the x axis, with constant acceleration a , while the equations for angular motion represent rotation about a fixed axis with constant angular acceleration α . Although, to avoid complication, we have not discussed the com-

ponent form of the equations for rotational motion, it is evident that both sets of equations may also be thought of as the component form of the general vector equations for the motion of a particle, with the linear equations representing the x component of the motion, while the angular equations represent the components along an unspecified axis of rotation.

Illustrative Example. The angular velocity of an airplane propeller is increased from 1,800 rpm to 2,200 rpm in 10 sec. Determine (a) its angular acceleration and (b) the angle traversed during this period.

(a) We may apply the definition of angular acceleration directly with the units given in the problem and get

$$\alpha = \frac{2,200 - 1,800 \text{ rpm}}{10 \text{ sec}} = 40 \frac{\text{rev}}{\text{min sec}},$$

and we may find the total rotation by the application of Equations (6-7) with these units as

$$\begin{aligned} \theta &= \frac{2,200 + 1,800}{2} \frac{\text{rev}}{\text{min}} \times \frac{1}{6} \text{ min} \\ &= 333 \text{ rev,} \end{aligned}$$

or (b) we may express the angular velocities in radians per second and apply Equations (6-7). The final angular velocity is

$$\omega = \frac{2\pi}{60} \times 2,200 \frac{\text{radians}}{\text{sec}},$$

and the initial angular velocity is

$$\omega_i = \frac{2\pi}{60} \times 1,800 \frac{\text{radians}}{\text{sec}},$$

so that

$$\alpha = \frac{\frac{2\pi}{60} (2,200 - 1,800) \frac{\text{radians}}{\text{sec}}}{10 \text{ sec}},$$

$$\alpha = 4.19 \frac{\text{radians}}{\text{sec}^2};$$

and

$$\theta = \frac{\frac{2\pi}{60} (2,200 + 1,800) \frac{\text{radians}}{\text{sec}}}{2} \times 10 \text{ sec,}$$

$$\theta = 2,090 \text{ radians.}$$

6-7 Uniform Circular Motion

In our previous study of accelerated motion, we restricted ourselves to the motion produced by the action of a force which remains constant in mag-

nitude and direction throughout the motion. The particular path followed by the body depended upon the relationship of the direction of the initial velocity and the direction of the force. When the initial velocity was parallel to the force, the motion was linear; when the initial velocity was at any other angle to the direction of the force, the motion was parabolic. We shall now consider another important type of motion, that of *uniform mo-*

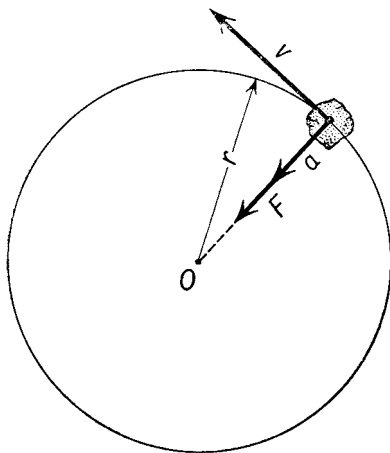

Fig. 6-3 Force F acting on a particle which is moving with uniform motion in a circular path is directed toward the center of the circle.

tion in a circle; that is, motion in a circular path in which the speed of the body remains constant in magnitude, but where the direction in which the body is moving changes constantly. We shall show that this type of motion is produced by a force which is always constant in magnitude but continually changing in direction in such a way that it is always at right angles to the velocity of the body.

Consider a particle moving with velocity v in a horizontal circular path of radius r , as in Figure 6-3. The direction of the velocity is always tangent to the path. If the force F acts at right angles to the velocity, it can have no component in the direction of the velocity; that is, it cannot change the speed of the body. The only effect of the force is to change the direction of the motion. Since the radius of a circle is always at right angles to the tangent, the force F must act along a radius. Furthermore, the force must be directed *toward the center of the circle*. According to Newton's first law, a particle moves with uniform velocity v in a straight line when the resultant force on it is zero, and such a motion would take it away from the center of the circle. To bring it back toward the center requires that there be an acceleration toward the center, and hence there must be an unbalanced force acting toward the center of the circle. One way of supplying such a force is to tie one end of a flexible string to the particle and to tie the other end to a pin at the center of the circle. A flexible string is used because such

a string can support only a tension, hence it must exert a pull toward the center on the particle.

6-8 Centripetal Acceleration

We can derive the expression for the acceleration of a particle moving in uniform circular motion in terms of the speed of the particle and the radius of the circle by considering two neighboring positions A and B of a particle moving with uniform speed in a circle of radius r , as shown in Figure 6-4(a).

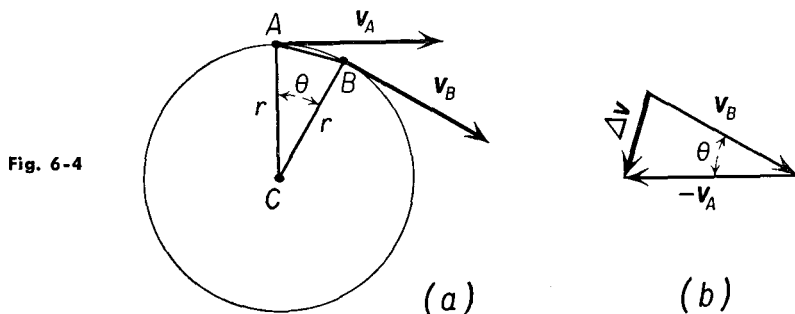

The velocity of the particle at A is \mathbf{v}_A and its velocity at B is \mathbf{v}_B . The change in velocity $\Delta\mathbf{v}$ of the particle is the vector difference of the two velocities $\mathbf{v}_B - \mathbf{v}_A$. To find the difference between these two velocities, we add $-\mathbf{v}_A$ to \mathbf{v}_B , as shown in Figure 6-4(b). If Δt is the time to go from A to B , the average acceleration $\bar{\mathbf{a}}$ of the particle is

$$\bar{\mathbf{a}} = \frac{\mathbf{v}_B - \mathbf{v}_A}{\Delta t} = \frac{\Delta\mathbf{v}}{\Delta t}.$$

Now the triangle formed by these vectors and the triangle ABC are similar, since they are both isosceles triangles and have equal angles θ . We may therefore write

$$\frac{\Delta v}{v_A} = \frac{\overline{AB}}{\overline{AC}} = \frac{\overline{AB}}{r}.$$

Dividing both sides of the equation by Δt and multiplying both sides of the equation by v_A , we obtain

$$\frac{\Delta v}{\Delta t} = \frac{\overline{AB}}{\Delta t \times r} v_A,$$

so that

$$\bar{\mathbf{a}} = \frac{\overline{AB}}{\Delta t \times r} v_A.$$

To find the instantaneous acceleration of the particle, we take the limit of \bar{a} as Δt approaches zero; the points A and B approach each other, and the chord \overline{AB} approaches the length of the arc \widehat{AB} ; the velocity v_A becomes equal to the velocity v at the limiting point, and the distance \overline{AB} may be replaced by $v \Delta t$. Substituting these values into the previous equation, we find

$$a = \frac{v^2}{r}. \quad (6-8)$$

A glance at Figure 6-4 shows that when the angle θ is very small, the vector $\Delta \mathbf{v}$ is at right angles to the velocity \mathbf{v}_A and is directed toward the center of the circle.

When an object moves in uniform circular motion with linear speed v , it is accelerated toward the center of the circle with an acceleration a given by $a = v^2/r$.

We call the acceleration of a particle moving in uniform circular motion *centripetal acceleration*; the word "centripetal" means "directed toward the center."

A particle moving in uniform circular motion with constant linear speed v may also be described as moving with uniform angular speed ω with the linear and angular speed related by Equation (6-4) as $v = \omega r$, where r is the radius of the circle in which the particle is moving. We may therefore rewrite Equation (6-8) in terms of ω as

$$a = \frac{v^2}{r} = \omega^2 r. \quad (6-9)$$

6-9 Centripetal and Centrifugal Forces

Knowing the magnitude and the direction of the acceleration of a particle moving in uniform circular motion, it is a simple matter to compute the force which acts on the particle. If the mass of the particle is m , we find, upon application of Newton's second law,

$$F = \frac{mv^2}{r} = m\omega^2 r \quad (6-10)$$

for the magnitude of the force acting toward the center to keep the body moving with uniform circular motion. The force acting toward the center is called the *centripetal* force. It must be remembered that the centripetal force acts *on* a body moving in a circular path.

Referring again to the particle that is being whirled around at the end

of a string, as in Figure 6-3, we note that the centripetal force is the pull of the string on the particle. From Newton's third law, the particle exerts an equal and opposite force on the string. This reaction is sometimes referred to as *centrifugal* force, meaning directed away from the center. If the string is cut during the circular motion, there will no longer be a force acting on the particle. The instant the string is cut, the particle will continue to move in the direction it was moving at the time; that is, the particle will go off at a tangent to the circle.

In ordinary conversation there is a great deal of confusion about the terms "centripetal force" and "centrifugal force." If one asks why the particle flies off when the string is cut, the answer seems always to be centrifugal force. If the question is raised as to why the passenger in a car seems to be thrown against the door when the car goes around a curve, the same answer invariably is given—centrifugal force. In terms of Newton's laws of motion, this is obviously incorrect. An observer, viewing the car turning the corner from some perspective above the car, would observe that the passenger, who has little or no radial force exerted on him by the slippery seat covers, moves in a straight line with uniform speed, while the car, which is acted on by the frictional force of the road, moves in a circular path. When the trajectories of the passenger and the side of the car intersect, the passenger says that he has been thrown against the door. The passenger views the world as though he were at its center, and if he finds himself in contact with the door, he assumes that he must have been forced toward it.

Illustrative Example. A stone weighing 0.5 lb tied to a string 2 ft long is placed on a smooth horizontal table. The other end of the string is tied to a pin at the center of the table. The stone is given a push for a short time, and acquires a speed of 6 ft/sec. (a) Determine the tension in the string. (b) If the breaking strength of the string is 15 lb, determine the maximum speed with which the stone can be whirled.

(a) The mass of this stone is

$$m = \frac{0.5 \text{ lb}}{32 \text{ lb/slug}} = \frac{1}{64} \text{ slug.}$$

The centripetal force F required to keep it moving in a horizontal circle of radius $r = 2$ ft with a speed of $v = 6$ ft/sec is, from Equation (6-10),

$$F = \frac{1}{64} \text{ slug} \times \frac{36 \text{ ft}^2/\text{sec}^2}{2 \text{ ft}},$$

so that

$$F = 0.28 \text{ lb.}$$

(b) If the breaking strength of the string is 15 lb, this represents the maximum centripetal force that the string can apply to the stone. Using this value for

F in Equation (6-10) and letting v be the unknown maximum speed of the stone, we get

$$15 \text{ lb} = \frac{1}{64} \text{ slug} \times \frac{v^2}{2 \text{ ft}},$$

from which
$$v^2 = 1,920 \frac{\text{ft}^2}{\text{sec}^2},$$

and
$$v = 43.9 \frac{\text{ft}}{\text{sec}}.$$

6-10 Banking of a Curved Road

A car rounding a curve can be considered as moving in an arc of a circle or, in some cases, in a series of such arcs of slightly different radii. In order to move the car in a circular path of radius r , an outside force must act on the car, and this force must be directed toward the center of the circle. In the

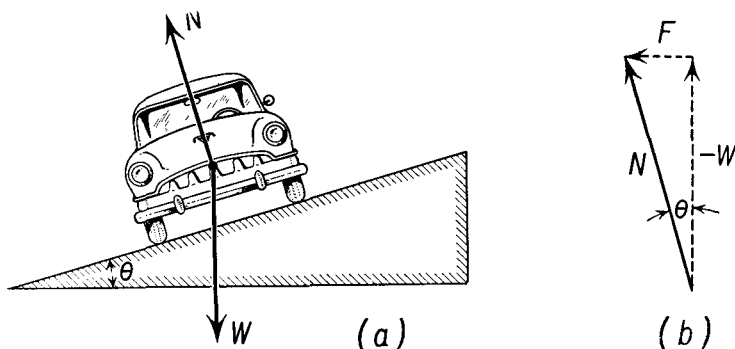

Fig. 6-5 (a) Car moving on a curve in a road banked at an angle θ to the horizontal. (b) The components of the normal force N are $-W$ and F .

case of an automobile rounding a curve, this force is supplied by the friction between the road and the tires. The frictional force which can be supplied by the contact between the road and the wheels of a car is variable, depending on the conditions of the road and the tires of the vehicle. It is much more desirable for design purposes to pretend that the road is smooth and to bank the road so that the normal force exerted by a smooth road has a horizontal component of magnitude and direction equal to the required centripetal force. The angle at which the road is banked will depend on the speed of the vehicle. Thus when a railroad curve is marked with a speed of, say, 40 mi/hr, this does not mean the maximum speed at which the turn should be traversed, but rather the speed for which the turn was

designed. In general, small variations from the design speed are compensated for by frictional forces.

An airplane moving through the air is affected by the lift of the air on the wings. In level flight this force is directed vertically upward. An airplane may execute a turn by banking in such a manner that the force on the wings has a horizontal component of the desired magnitude and direction to supply the centripetal force necessary for the circular motion.

In Figure 6-5(a), if a car is to move in a circular path, the normal force N exerted on the car by the road must both support the weight of the car W and supply a horizontal component F equal to the required centripetal force. From Figure 6-5(b) we see that the horizontal component is

$$F = N \sin \theta = \frac{mv^2}{r},$$

and the vertical component is

$$-W = N \cos \theta = mg.$$

From these equations we find that

$$\tan \theta = \frac{v^2}{rg} \quad (6-11)$$

Essentially the same analysis can be applied to the banked turn of an airplane, as illustrated in Figure 6-6. We note from Equation (6-11) that the angle of inclination of the road, or the angle at which an airplane should be banked upon making a turn, depends only upon the speed and the radius of the turn and does not depend on the mass of the vehicle. It is this latter consideration which makes it possible to bank highways.

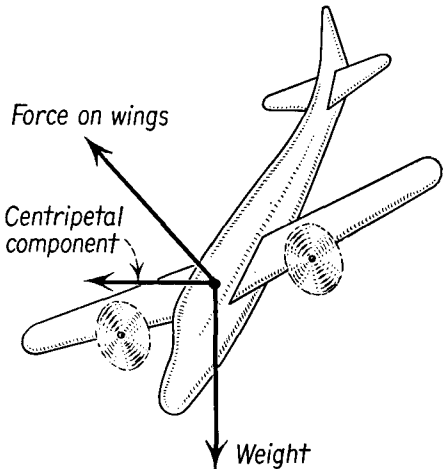

Fig. 6-6 The banked turn of an airplane.

Illustrative Example. A truck weighing 2.5 tons rounds a curve in a level road at 30 mi/hr. The curve is in the form of a circular arc of 1,200 ft radius. (a) Determine the lateral force exerted by the road on the tires to keep the truck moving in its circular path. (b) Find the angle of banking if the turn is to be executed without friction.

(a) The road must exert a force toward the center of the circle in which the car is moving of magnitude $F = \frac{mv^2}{r}$. Now

$$m = \frac{W}{g} = \frac{2.5 \times 2,000}{32} \text{ slugs}; \quad v = 30 \frac{\text{mi}}{\text{hr}} = 44 \frac{\text{ft}}{\text{sec}}; \quad r = 1,200 \text{ ft};$$

substituting these values, we get

$$F = \frac{2.5 \times 2,000}{32} \text{ slugs} \times \frac{\left(44 \frac{\text{ft}}{\text{sec}}\right)^2}{1,200 \text{ ft}},$$

from which $F = 252 \text{ lb} = 0.126 \text{ ton}$.

(b) The angle of banking may be determined from Equation (6-11). Substituting numerical values, we have

$$\begin{aligned} \tan \theta &= \frac{v^2}{rg} = \frac{(44 \text{ ft/sec})^2}{1,200 \text{ ft} \times 32 \text{ ft/sec}^2} \\ &= 0.0504, \\ \theta &= 2.9^\circ. \end{aligned}$$

6-11 Motion in a Vertical Circle

When circular motion takes place in a vertical plane, as, for example, when an airplane loops the loop, the motion is not uniform, and the speed varies from point to point on the circle. Consider a particle which acquires speed

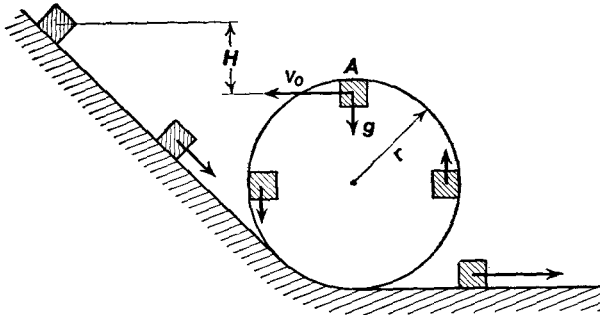

Fig. 6-7

by sliding down a frictionless inclined plane, as shown in Figure 6-7, and then starts up the inside of a vertical circular track. It is obvious that the danger point is the highest point A of the track. The particle must negotiate this point with the proper speed if it is to travel safely around the track.

Suppose the particle is at point A under the track. The particle will stick to the track as long as it moves fast enough so that the track is required to exert some force against it to provide the necessary centripetal acceleration. The minimum speed the particle may have is one in which the force exerted by the track is zero. At this critical speed v_0 , the only force acting on the particle is the force of gravity. Consequently, the

acceleration of gravity g must be equal to the required centripetal acceleration; that is,

$$g = \frac{v_0^2}{r},$$

from which

$$v_0 = \sqrt{rg}.$$

If the speed of the particle is greater than this minimum speed, its acceleration toward the center will be greater than g ; this means that the

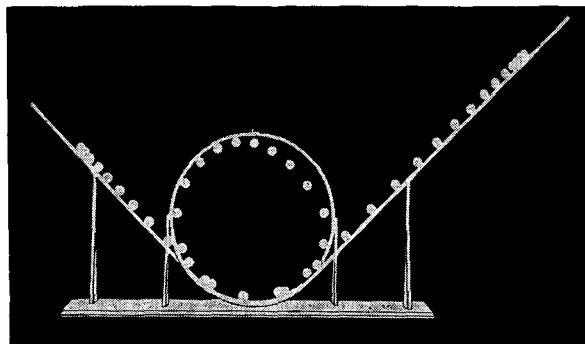

Fig. 6-8 Multiflash photograph of a ball which starts on an inclined plane but does not acquire sufficient speed to loop the loop in a vertical circle. (Reproduced by permission from *College Physics*, 2nd ed., by Sears and Zemansky, 1952; Addison-Wesley Publishing Company, Inc., Reading, Mass.)

track will have to exert a force toward the center to keep it moving in the circular path; the particle will stick to the track. If its speed is less than the minimum safe value of v_0 , the particle will leave the track and follow the parabolic path of a projectile (see Figure 6-8).

6-12 Angular Acceleration and Linear Acceleration

When a rigid body rotates about a fixed axis with constant angular acceleration α , each particle of the body has the same angular acceleration, but the linear acceleration \mathbf{a} of each particle will be different. The linear acceleration \mathbf{a} of a particle may be resolved into two components, one component \mathbf{a}_t tangent to the path and given by the time rate of change of the *speed* of the particle, and the other component \mathbf{a}_c , the centripetal acceleration, directed perpendicular to the velocity and parallel to the radius of the circle in which the particle is moving.

The relationship between the length of arc s subtended by an angular displacement θ on a circle of radius r is well known as the basis of definition

of the radian as

$$s = \theta r.$$

Differentiating this equation once with respect to time for circular motion of constant r , we obtain

$$\frac{ds}{dt} = \frac{d\theta}{dt} r.$$

By definition, the instantaneous linear speed v is equal to $\frac{ds}{dt}$, while the instantaneous angular speed ω is equal to $\frac{d\theta}{dt}$, and we may rewrite this equation as

$$v = \omega r,$$

which we have seen before as Equation (6-4). If we differentiate once again with respect to time, neglecting the change in direction of \mathbf{v} and considering only the change in magnitude, that is, the change in the angular speed of the particle, we obtain

$$\frac{dv}{dt} = \frac{d\omega}{dt} r.$$

By definition, the rate of change of the linear speed is the component of the acceleration measured along the path, hence the *tangential acceleration* a_t , while the rate of change of the angular velocity is the angular acceleration α . Thus we find

$$a_t = \alpha r. \quad (6-12)$$

We have already seen that the central, or radial, component of the acceleration which is due to the change in direction of \mathbf{v} may be expressed in terms of the angular velocity from Equation (6-9) as

$$a_c = \frac{v^2}{r} = \omega^2 r. \quad (6-13)$$

The tangential component of the acceleration depends upon the angular acceleration α , while the central component of the acceleration depends upon the angular velocity ω . Both the tangential and the central, or radial, components of acceleration depend upon the distance of the particle from the axis of rotation. If the particle is moving with uniform speed in a circle, the radial acceleration is the total acceleration. If the speed is increasing or decreasing while the particle is moving in a circle, then its total acceleration \mathbf{a} is made up of two components \mathbf{a}_t and \mathbf{a}_c . Since these two components are at right angles to each other, we have

$$a = \sqrt{a_t^2 + a_c^2}. \quad (6-14)$$

Illustrative Example. A circular pulley 4 ft in diameter is mounted so that it can rotate about an axis passing through its center. One end of a cord which is

wound around the pulley is being pulled in a horizontal direction, as shown in Figure 6-9, with an acceleration of 6 ft/sec². (a) Determine the angular acceleration of the pulley. (b) Assuming the pulley to have been at rest initially, determine the acceleration of the lowest point *B* on the rim of the pulley at the end of 10 sec.

(a) The point *A* at the top of the pulley is the point at which the rope just leaves the pulley. The tangential component of the acceleration a_t of this point is the same as the acceleration of a point on the rope. We can, therefore, use the acceleration of this point for determining the angular acceleration of the pulley. From Equation (6-12) we get

$$\alpha = \frac{a_t}{r} = \frac{6 \text{ ft/sec}^2}{2 \text{ ft}} = \frac{3 \text{ radians}}{\text{sec}^2}.$$

(b) The angular speed of the pulley at the end of 10 sec is, from Equations (6-7),

$$\omega = \omega_i + \alpha t.$$

Since the pulley starts from rest, $\omega_i = 0$, and we have

$$\omega = 3 \frac{\text{radians}}{\text{sec}^2} \times 10 \text{ sec} = 30 \frac{\text{radians}}{\text{sec}}.$$

Since the angular acceleration is clockwise, the lowest point on the rim of the wheel is moving toward the left. The two components of the acceleration at this instant are

$$a_t = \alpha r = 6 \frac{\text{ft}}{\text{sec}^2}, \text{ to the left,}$$

and

$$a_c = \omega^2 r = \left(30 \frac{\text{radians}}{\text{sec}} \right)^2 \times 2 \text{ ft} = 1,800 \frac{\text{ft}}{\text{sec}^2}.$$

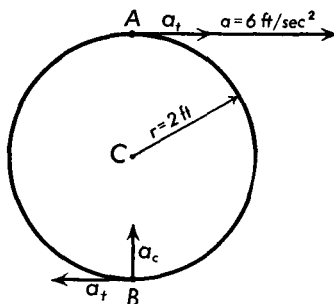

Fig. 6-9

6-13 Periodicity of Uniform Circular Motion

One of the interesting properties of uniform circular motion is that it is *periodic*; that is, a particle in uniform circular motion traverses a full circumference in a time T . This time T is called the *period* of the motion. The period remains the same no matter how often the motion is repeated.

In one complete revolution the angular displacement is 2π radians, and the distance traversed is $2\pi r$ where r represents the radius of the circle. The period, or time, for one complete revolution is therefore equal to

$$T = \frac{2\pi r}{v}, \tag{6-15}$$

or

$$T = \frac{2\pi}{\omega}.$$

We have already shown that the acceleration of a particle in uniform circular motion is

$$a = \omega^2 r.$$

Substituting the value of ω , from Equation (6-15), yields

$$a = \frac{4\pi^2 r}{T^2} \quad (6-16)$$

for the relationship between acceleration and period for uniform circular motion.

6-14 Planetary Motion

One important type of periodic motion which has been studied and recorded for centuries is that of the bodies constituting the solar system. Theories concerning these bodies have changed with the centuries, and to a certain extent these changes mirror man's intellectual progress. Of course, it has not always been known that these bodies were part of a system which was tied to the sun, but knowledge of the planets predates recorded history, for after the sun and the moon these bodies are often the most prominent objects in the sky that are visible to the naked eye, and they have the very special character that they wander in the heavens among the fixed stars.

Among the early theories which held sway for centuries was that associated with the name of Claudius Ptolemy (c. A.D. 150) and known as the *geocentric* theory of the universe. In the geocentric theory the earth was assumed to be at the center of the universe, and the sun, the moon, the planets, and the stars were thought to move around it in complicated paths. In a sense, this was a theory which most nearly corresponded to direct observation and to man's rather egocentric view of his own place in the universe.

Several centuries before Ptolemy, Aristarchus of Samos (c. 310–230 B.C.) proposed a theory in which the sun was fixed at the center of the universe and the earth revolved around the sun in a circular orbit, called the *heliocentric* theory of the universe. He also recognized that the stars appeared fixed in position because their distances from the earth were tremendous in comparison with the distance of the earth from the sun. Very few of the early astronomers accepted the heliocentric conception of the universe; from the second to the sixteenth century, only the geocentric theory of Ptolemy was taught and used. In the sixteenth century Nikolaus Copernicus (1473–1543) revived and extended the heliocentric theory of Aristarchus and thus started a revolution in scientific thought which was carried forward by Kepler, Galileo, and Newton. In the heliocentric theory

of Copernicus (see Figure 6-10), the sun was considered at the center of the universe, the planets revolved around the sun in circular orbits, and the fixed stars were assumed to lie in a sphere surrounding the solar system.

Copernicus' theory was not readily accepted by scientists of that period. Tycho Brahe (1546-1601), a famous Danish astronomer, made very careful and accurate measurements of the motions of the planets and the

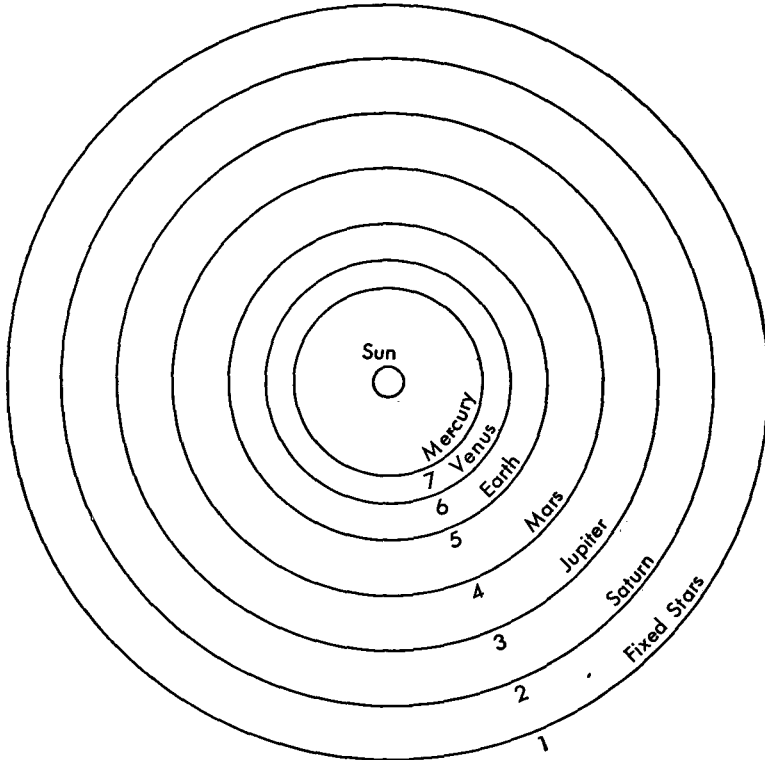

Fig. 6-10 Orbits of the planets and the fixed stars in the heliocentric theory of the universe according to Copernicus.

sun. He had never become convinced of the correctness of the Copernican hypothesis, but his extensive and careful measurements which he bequeathed to another astronomer, Johannes Kepler (1571-1630), laid the foundations of modern astronomy. It may be noted here that Brahe's observations were made without telescopic instruments. The telescope had not yet been invented.

From his study of the data accumulated by Tycho Brahe, Kepler deduced three laws which accurately described the motions of the planets about the sun. Kepler's three laws follow.

First law: *Each planet moves around the sun in an elliptic path (or orbit) with the sun at one focus of the ellipse.*

Second law: *As the planet moves in its orbit, a line drawn from the sun to the planet sweeps out equal areas in equal intervals of time (see Figure 6-11).*

Third law: *The squares of the periods of the planets are proportional to the cubes of their mean distances from the sun.*

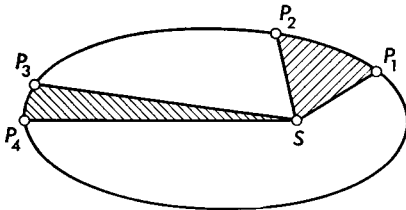

Fig. 6-11 The path of a planet about the sun S is an ellipse. $P_1P_2P_3P_4$ represent positions of a planet in its orbit at different times. The speed of a planet is such that an imaginary line joining the sun and the planet would sweep out equal areas in equal intervals of time. For example, area SP_1P_2 is equal to area SP_3P_4 .

It can be seen that the simplified picture of the planetary system proposed by Copernicus is not sufficiently accurate; however, the elliptical orbits of the planets are not far removed from circles.

In large measure it was to explain Kepler's laws that Newton invented the laws of motion and the law of universal gravitation that we shall discuss in the next section. From astronomy, from pure speculation about the motion of the planets, has come the stimulus for much of today's engineering and for the foundations of modern science. Centuries of careful observation and profound thought have been distilled into a few carefully worded statements about the behavior of material bodies, and today every schoolboy knows more about the universe than did Kepler or even Newton.

6-15 Newton's Law of Universal Gravitation

Although Kepler's laws give an adequate description of the motions of the planets, they do not give a physical explanation of the cause of the motion. Newton, having introduced the concept of force into mechanics, now applied this concept to help explain the cause of the motions of the planets around the sun. He developed the *law of universal gravitation* which states that *any two bodies in the universe attract each other with a force which is directly proportional to the product of the masses of the two bodies and inversely proportional to the square of the distance between them.*

Stated in mathematical form, this law becomes

$$F \propto \frac{Mm}{r^2},$$

where M is the mass of one body, m is the mass of the other body, r is the distance between them, and F is the force that one body exerts on the

other. This proportionality may be replaced by an equation by replacing the proportional sign by an equal sign and a constant of proportionality, thus

$$F = G_0 \frac{Mm}{r^2}, \quad (6-17)$$

where G_0 is the constant of proportionality known as the *universal constant of gravitation*, or the *gravitational constant*. The force of gravitation is directed along a line joining the two bodies.

Newton's law of universal gravitation, when combined with his laws of motion, predicts with great accuracy the motions of the planets. In fact, astronomy is one of the more important observational means of verification of Newtonian mechanics. In the last 40 or 50 years, it has been found that Newton's laws of motion have had to be extended to include some additional concepts in order to deal properly with atoms and molecules by a theory called *quantum mechanics*, and have had to be extended for even larger aggregates of matter when these are moving with extremely high speeds. It is extremely impressive, however, that Newton's laws have been shown to be a correct formulation of the rules of order which nature imposes upon material objects in the range of size from microscopic to astronomical, a range of from 10^{-6} m to 10^9 m, or more. The enormous success of the Newtonian view of the rational character of the world has had repercussions in other areas of human experience, and the philosophy of rationalism owes much of its stimulus to the great success of physics and astronomy in developing a rational view of nature.

Newton's law of universal gravitation is applicable to all particles in the universe. To use it most fully, it is necessary to evaluate the constant G_0 . Of course the numerical value of G_0 will depend upon the units used for mass, force, and distance. Since the units appropriate to these quantities have already been defined through the equation $F = ma$, we cannot set G_0 equal to 1 but must determine its value experimentally. We can give G_0 a simple physical interpretation, no matter what system of units is used, by imagining two unit masses placed a unit distance apart; that is, $M = 1$, $m = 1$, and $r = 1$. The force F_1 with which two such masses attract each other is, from Equation (6-17),

$$F_1 = G_0;$$

that is, G_0 can be interpreted as the force with which two unit masses will attract each other when placed a unit distance apart.

The first experimenter to evaluate G_0 was Henry Cavendish (1731–1810). One method of determining the gravitational constant G_0 makes use

of a very delicate torsion balance such as that sketched in Figure (6-12). This consists of a fine elastic fiber AB suspended from some support at A ; a small stiff metal rod CD is fastened to B . Two identical metal spheres,

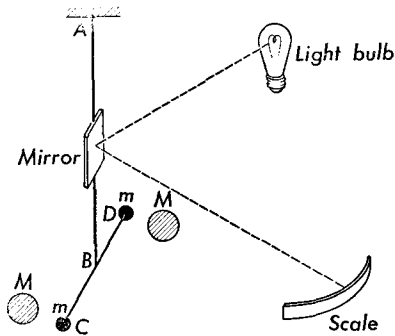

Fig. 6-12 Method of determining the gravitational constant G_0 using a delicate torsion balance.

usually silver or gold, each of mass m , are mounted on the ends CD . Two much more massive spheres made of lead are placed near the small spheres, one in front of the sphere at D , the other behind the sphere at C . Each of the lead spheres has a mass M . The force of attraction between each lead sphere and the small metal sphere near it produces a torque about AB as an axis; the two torques are in the same direction and cause the fiber to twist through a small angle. The angle of twist can be measured by reflecting a beam of light from a small mirror attached to the fiber onto a scale.

By shifting the positions of the large lead spheres so that one is now behind D and the other in front of C , the fiber is made to twist in the opposite direction. From a calibration of the fiber, the force F that each lead sphere of mass M exerts on the small metal sphere of mass m can be computed. The distance r between the centers of the spheres is also measured. Putting these data into Equation (6-17) will give the value of F .

The value of G_0 determined experimentally is

$$G_0 = 6.670 \times 10^{-8} \frac{\text{dyne cm}^2}{\text{gm}^2} = 6.670 \times 10^{-11} \frac{\text{nt m}^2}{\text{kg}^2}.$$

Because the force of gravitational attraction between ordinary objects is extremely small, we are not normally conscious of the gravitational attraction between adjacent objects, and we neglect it entirely in engineering calculations in comparison to the force of the earth's attraction and to the forces exerted by structural members upon each other.

6-16 The Gravitational Field

The force that exists between two particles because of their masses acts no matter how far apart these masses may be. This is one example of a type of force which is called an *action-at-a-distance* force, for it requires no material medium to transmit the force. We know, for example, that the space between the planets of the solar system is essentially empty. There is another way of thinking about gravitational forces and that is to imagine

that in the space all around a particle, and extending to infinity in all directions, there exists a *gravitational field*. Whenever any other particle finds itself in this gravitational field, it will experience a force F , given by Equation (6-17). We can define a new term called the *intensity of the gravitational field at any point in space as the force F which acts on a particle at this point divided by the mass m of the particle situated there*. Let us denote the gravitational field intensity by the letter I ; then

$$I = \frac{F}{m}. \quad (6-18)$$

Note that the gravitational field intensity I is a vector quantity. Substituting the value of F from Equation (6-17) to obtain the magnitude of I yields

$$I = G_0 \frac{M}{r^2}. \quad (6-19)$$

Equation (6-19) shows that the gravitational field intensity varies inversely with the square of the distance from the particle of mass M which is the source of the field. The intensity is a vector quantity; its direction is that of the force F which acts on a particle placed anywhere in the field, and since the force is always one of attraction, its direction is always toward the mass M .

Fig. 6-13 Radial gravitational field around a small concentrated mass M . The number of lines of force through a unit area at P is proportional to the intensity I of the gravitational field at P .

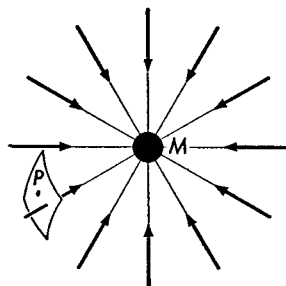

We can develop a graphical method for representing the gravitational field so that it will show at a glance both the magnitude and the direction of the field intensity. This is illustrated in Figure 6-13 in which radial lines are drawn converging upon the mass M ; a scale can be chosen so that the number of lines passing perpendicularly through a unit area at any point such as P will be proportional to the intensity I at that point. The direction of the field is given by the direction of the lines. Such lines are called *lines of force*.

An interesting case is that of the earth's gravitational field. Newton was the first to prove that the field outside a spherical mass is identical with

that of a mass concentrated at the center of the sphere. Hence, at points outside the earth's surface, the gravitational field intensity is given by Equation (6-19). However, we have been using the term "weight" to describe the force which the earth exerts on a mass m placed anywhere in its field. The intensity of the earth's gravitational field at the surface of the earth I_e is therefore

$$I_e = \frac{W}{m} = g. \quad (6-20)$$

The term which we have been calling the acceleration of a freely falling body is identical with the gravitational field intensity. From Equation (6-20) we note that the units for gravitational field intensity can be either those of acceleration or the ratio of force to mass, such as lb/slug, dynes/gm, nt/m.

Comparing Equations (6-19) and (6-20), we find that

$$g = G_0 \frac{M}{r^2} \quad \text{for } r \geq R_e, \quad (6-21)$$

in which M is now the mass of the earth, and r is the distance of a point from the center of the earth. Equation (6-21) holds only for points outside the surface of the earth, that is, for distances r greater than the radius of the earth R_e . We have treated g as though it were independent of altitude in the solution of projectile problems. We see that if we set $r = R_e + h$, where h is the height above the surface of the earth, we may take h as small compared to R_e and to a good approximation we may set $r = R_e$.

Illustrative Example. Equation (6-21) may be used to determine the mass of the earth once G_0 has been measured. For this reason the experiment measuring the value of G_0 is popularly called "weighing the earth." Taking known values of $g = 9.80 \text{ m/sec}^2$, $G_0 = 6.67 \times 10^{-11} \text{ nt m}^2/\text{kg}^2$, $r = R_e = 6,380 \text{ km} = 6.380 \times 10^6 \text{ m}$, and solving for M , we get

$$\begin{aligned} M &= \frac{gR^2}{G_0} \\ &= \frac{9.8 \frac{\text{m}}{\text{sec}^2} \times (6.38 \times 10^6 \text{ m})^2}{6.67 \times 10^{-11} \frac{\text{nt m}^2}{\text{kg}^2}}, \end{aligned}$$

from which $M = 5.98 \times 10^{24} \text{ kg}$.

Illustrative Example. With the development of modern high-speed rockets, it is interesting to inquire what speed a particle should have in order to become a satellite of the earth, that is, to travel in an approximately circular path around the earth.

Any particle traveling with a speed v on a circular path of radius r has an acceleration toward the center of the circle of

$$a = \frac{v^2}{r}.$$

If it is traveling in the earth's gravitational field, then approximately $a = g$, so that

$$g = \frac{v^2}{r},$$

from which

$$v = \sqrt{gr}.$$

Near the surface of the earth $r = 4,000$ mi, and

$$g = 32 \frac{\text{ft}}{\text{sec}^2} = \frac{32}{5,280} \frac{\text{mi}}{\text{sec}^2}.$$

Substituting these values into the above equation yields

$$v = \sqrt{\frac{32 \text{ mi}}{5,280 \text{ sec}^2} \times 4,000 \text{ mi}} = 5 \frac{\text{mi}}{\text{sec}}.$$

6-17 The Curvature of Space

From Newton's first law, we might infer that one of the consequences of this law is that an observer cannot measure his own velocity except with respect to an outside reference frame. Velocity is a relative quantity rather than an absolute quantity. This concept was one of the building blocks of the theory of special relativity by Albert Einstein (1879–1955) and is now part of the basic structure of physics. Another concept due to Einstein is the impossibility of distinguishing, when inside a closed system, between a gravitational field and accelerated motion. Let us consider an observer moving through space in a rocket ship which is completely enclosed. He has on board a massive object which is hung from a spring balance. A reading of the balance will tell him either that he is being accelerated or that he has entered a gravitational field, but no measurement he can make within the rocket ship can distinguish between the two possibilities.

With this as a starting point, we see that we may consider any gravitational field as though it were an accelerated enclosure. Even a ray of light traversing an intense gravitational field must behave as though it were traversing an accelerated chamber. A ray of light passing horizontally through an elevator accelerated in the upward direction would appear to be deflected toward the floor; that is, it would enter the elevator through an aperture in the side wall at some distance s above the floor and would

leave the elevator through an aperture in the opposite wall at some lesser distance s' above the floor. To an observer in the elevator, the light beam would appear to have been deflected toward the floor. A massive object located in an elevator which is being accelerated in the upward direction behaves as though there were a gravitational field directed toward the floor. By analogy, we would expect a ray of light passing through an intense gravitational field to be deflected toward the source of the field. Measurements made, during a solar eclipse, of starlight passing by the edge of the sun indicate that the light is bent by the sun's gravitational field, in quantitative agreement with these ideas.

In this connection it is of interest to reconsider just what we mean by a straight line in space. In practice, when we wish to determine the straightness of a straightedge or when we wish to determine the straight line connecting two points, we sight along the straightedge or we look through a surveyor's transit. In practice, a straight line is defined as the path of a ray of light. Since the path of a ray of light is curved in the vicinity of a gravitational field, we must infer that space itself is curved in the vicinity of a gravitational field.

Problems

6-1. A flywheel of a steam engine is rotating with a uniform angular speed of 180 rpm. (a) Express this angular speed in radians per second. (b) Determine the linear speed of a portion of this wheel which is at a distance of 2 ft from the center. (c) Through what angle, in degrees, will the wheel have rotated in 10 sec?

6-2. The fuel supply is shut off from an engine when its angular speed is 1,800 rpm. It stops rotating 15 sec later. (a) Determine its angular acceleration, assuming it to be constant. (b) Through what angular displacement, in radians, will the wheel have rotated before it comes to rest?

6-3. The angular speed of an automobile engine is increased from 3,000 rpm to 3,600 rpm in 20 sec. (a) Determine its acceleration, assuming it to be uniform. (b) Determine the number of revolutions made by the engine in this time.

6-4. A uniformly accelerated wheel initially is rotating with an angular velocity of 10 radians/sec, and after 150 radians is rotating with an angular velocity of 25 radians/sec. (a) Determine the angular acceleration of the wheel. (b) For how long a time was the acceleration applied?

6-5. Derive Equation (6-7b) from the definitions of angular velocity and angular acceleration.

6-6. Derive Equation (6-7c) from the definitions of angular velocity and angular acceleration.

6-7. Derive Equations (6-7d) and (6-7e).

6-8. A drum 2 ft in diameter is free to turn on a fixed horizontal axis, as shown in Figure 6-14. A rope is wrapped around the drum. The free end of the rope is tied to a hanging weight which is observed to fall with an acceleration of

16 ft/sec² as the rope unwinds from the drum. If the weight starts from rest, (a) determine the angular velocity of the drum at the end of 5 sec. (b) If the weight has a mass of 2 slugs, determine the tension in the rope. (c) Determine the angular displacement of the drum at the end of 10 sec.

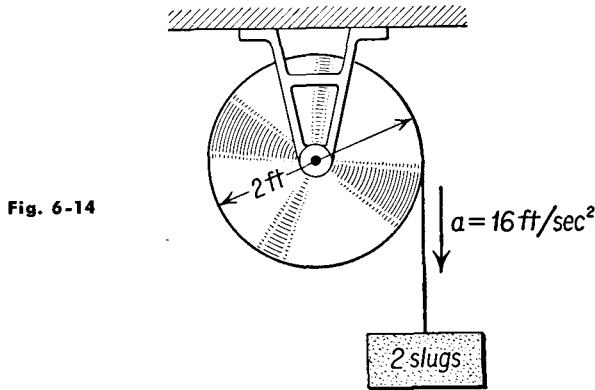

6-9. A stone whose mass is 150 gm is attached to a cord 30 cm long and placed on a smooth horizontal table. The stone is then whirled in a circular path with a speed of 25 cm/sec. Determine (a) the tension in the cord and (b) the acceleration of the stone.

6-10. A car weighing 3,000 lb rounds a curve of 600 ft radius at a speed of 40 mi/hr. What lateral force must the ground exert on the tires to keep this car moving in this circular path? In what direction is this force?

6-11. Assume that the moon is moving in a circular path of 380,000 km radius about the earth. The period of revolution is 27.3 days. (a) Calculate the acceleration of the moon. (b) Calculate the mass of the earth.

6-12. An automobile rounds a curve of 800 ft radius at a speed of 50 mi/hr. What is the minimum value of the coefficient of friction between the tires and the road in order that there be no skidding?

6-13. (a) Determine the angle at which a road should be banked if the radius of the curve is 1,600 ft and if it is to supply the necessary centripetal force to a car traveling at 50 mi/hr. (b) If the same car is driven at 75 mi/hr over the banked road, what must be the coefficient of friction between the tires and the road in order that there be no skidding?

6-14. Uniform circular motion may be described in polar coordinates in terms of the equations $r = R$, a constant, and $\theta = \omega t$. The rectangular coordinates of a point in uniform circular motion are given by the equations

$$x = R \cos \omega t \quad \text{and} \quad y = R \sin \omega t.$$

From these relationships, show by the use of the calculus that $a = \omega^2 R$.

6-15. A stone of mass 100 gm is tied to the end of a string 50 cm long. The stone is twirled as a conical pendulum, so that it rotates in a horizontal circle 30 cm in radius, as shown in Figure 6-15. Determine (a) the angular speed of rotation and (b) the tension in the string.

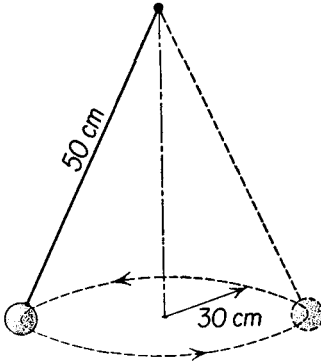

Fig. 6-15 Conical pendulum.

6-16. A small car whose mass is 25 gm moves on the inside of a vertical circular track of radius 40 cm. (a) Determine the minimum speed that the car must have at the top of the circular track in order to move in this circular path. (b) Assuming that it has the minimum safe speed at the top of the track, determine its speed at the bottom of the track. What is the force that the track exerts on the car (c) at the top of the track and (d) at the bottom of the track?

6-17. A pilot pulls his plane out of a dive by moving in the arc of a vertical circle with a speed of 600 mi/hr. (a) Determine the minimum radius of this circle if his acceleration is not to exceed $7g$ at the lowest point. (b) Determine the force which acts on a pilot weighing 180 lb.

6-18. The period of Jupiter is 11.86 years. With the aid of Kepler's third law, determine its distance from the sun. The distance from the earth to the sun is 1.49×10^8 km.

6-19. Assuming the earth to move around the sun in a circular orbit of radius 1.49×10^8 km with a period of 365.3 days, compute (a) the speed of the earth in its orbit and (b) the acceleration of the earth relative to the sun. The mass of the earth is 5.98×10^{24} kg. (c) Determine the gravitational force between the sun and the earth.

6-20. Two blocks, each of mass 1 kg, rest on a horizontal table a distance of 1 m apart. (a) What is the force with which they attract each other? (b) What is the minimum value of the coefficient of static friction if the blocks are to remain at rest on the table?

6-21. In Equation (6-21) set $r = R + h$, where R is the radius of the earth and h is the height above the surface of the earth. Expand $r^{-2} = (R + h)^{-2}$ by the binomial expansion. What is the greatest value h may have if g is to remain a constant (a) within 1 per cent? (b) Within 0.1 per cent?

6-22. The equation $x^2 + y^2 = r^2$ defines a circle centered at the origin. If this equation is differentiated twice with respect to time, an equation relating the x and y components of velocity and acceleration results. For the special case of $x = r, y = 0$ show that

$$a_x = -\frac{v^2}{r}.$$

6-23. The distance from the earth to the sun is 149×10^6 km. Assuming that the earth's orbit around the sun is circular, calculate the mass of the sun.

6-24. In an experiment on the determination of the universal constant of gravitation G_0 , a lead sphere whose mass is 2,000 gm was placed near a gold sphere of mass 4 gm with their centers 6 cm apart. The force of attraction between them was found to be 1.45×10^{-5} dyne. Determine the value of G_0 from these data.

6-25. Assuming that a planet moves in a circular orbit of radius r around the sun of mass M with a period T , show that

$$T^2 = \frac{4\pi^2}{G_0 M} r^3.$$

Compare this with Kepler's third law.

6-26. A satellite, launched by Russia and called "Sputnik," traverses an orbit around the earth at an altitude of about 500 miles. Determine (a) the value of g at this altitude; (b) the linear velocity of the satellite; and (c) its period.

6-27. Two equal masses of 2 slugs each are joined by a rod of negligible mass which is pivoted at its center. The system rotates in a horizontal plane at an angular velocity of 20 rad/sec. Each mass is 1 ft from the axis of rotation. What is the tension in the rod?